

Koyo®

Ball & Roller Bearings



JTEKT

JTEKT CORPORATION

CAT. NO. B2001E-3

1 Structures and types ... A 1	4 Selection of arrangement A 20	7 Tolerances A 52
2 Outline of selection A 14	5 Selection of dimensions A 24	8 Limiting speed A 78
3 Selection of type A 16	6 Boundary dimensions and bearing numbers A 46	9 Fits A 80

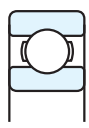

Open type ... B 8
(68, 69, 160, 60)
(62, 63, 64)

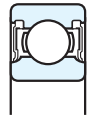

Shielded/sealed type ... B 20
(Z, RU)
(RD, RS)

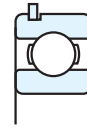

Locating snap ring type ... B 32
(N)
(NR)



Single-row ... B 60
(79, 70, 72, 73, 74)
(ACH9, ACHO)

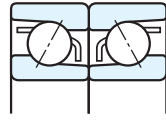

Matched pair ... B 92
(DB, DF)
(DT)

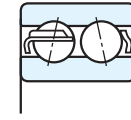

Double-row ... B 124
(32, 33, 52, 53)
(52...2RS, 53...2RS)

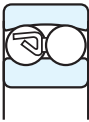

Open type ... B 136
(12, 22)
(13, 23)

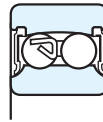

Sealed type ... B 144
(22...2RS)
(23...2RS)

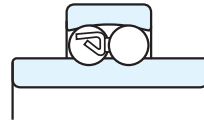

Extended inner ring type ... B 148
[112, 113]



NU



NJ



NUP



N



NF

Single-row ... B 158
(NU10, NU2, NU22, NU32)
(NU3, NU23, NU33, NU4)

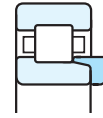

Thrust collars ... B 184
[HJ]



Metric series ... B 204
Inch series B 236
(329, 320, 330, 331, 302, 322)
(332, 303, 303D, 313, 323, ISO)

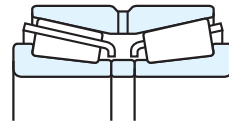

TDO type B 280
(462, 463, 46T302, 46T322)
(46T303, 46T303D, 46T323)

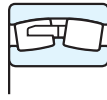

R, RR

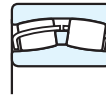

RH, RHR

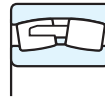

RHA

... B 306
(239, 230, 240, 231, 241)
(222, 232, 213, 223)



Adapter assemblies ... B 330

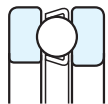

Single direction ... B 350
(511, 512, 513, 514)
(532, 533, 534)
(532U, 533U, 534U)



Double direction ... B 360
(522, 523, 524)
(542, 543, 544)
(542U, 543U, 544U)

Needle roller and cage ass'y ... B 388

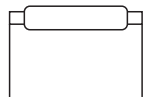

Drawn cup type ... B 402

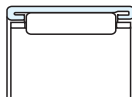

Machined ring type ... B 424

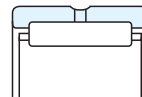

Thrust ... B 440

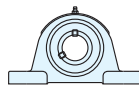

B 470



B 490

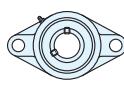

B 500



B 510

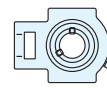

B 518

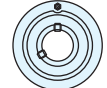

B 524

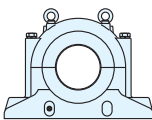

Split type ... B 544
[SN, SSN, SD]

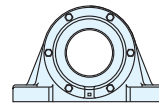

One-piece type ... B 570
[V]

- Ceramic & **EXSEV** bearing series C 1
(Vacuum ball bearings, ceramic bearings,
self-lubricating clean ball bearings,
linear ball bearings for vacuum)
- K-series super thin section ball bearings C 27

- Bearings for machine tool spindles
(for support of axial loading) C 47
- Precision ball screw support bearings
and bearing units C 65

- Supplementary tables D 1 – D 28

10 Internal clearance A 93	13 Materials A 122	16 Failures A 144
11 Preload A 106	14 Shaft and housing design A 125	
12 Lubrication A 111	15 Handling A 133	

Extra-small & miniature ... B 38
(flanged type ... B 44)

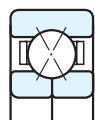
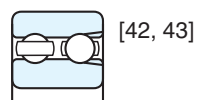
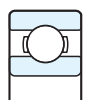

Four-point contact ... B 130
[62...BI, 63...BI]

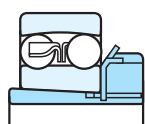

Adapter assemblies ... B 150

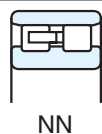

NN



NNU

Double-row ... B 194
(NN30
NNU49)

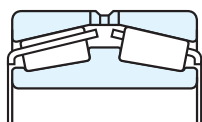

TDI type B 296
[452, 453]



Withdrawal sleeves ... B 338



... B 368
[292, 293, 294]

Stud type track rollers
(cam followers) ... B 450

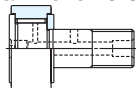

Yoke type track rollers
(roller followers) ... B 454



(Miniature one-way clutches)
... B 460

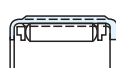

• Ball bearings for units B 528

• Full complement type cylindrical roller bearings for crane sheaves C 71
• Rolling mill roll neck bearings C 81
• Bearings for railway rolling stock axle journals C 139

• Linear ball bearings C 149
• Accessories C 163

Technical section

Deep groove ball

bearings

Angular contact ball

bearings

Self-aligning ball

bearings

Cylindrical roller

bearings

Tapered roller

bearings

Spherical roller

bearings

Thrust ball, Spherical thrust roller

bearings

Needle roller

bearings

Ball bearing units

Plummer blocks

Special purpose

bearings

Bearing specification tables

Supplementary tables

Koyo[®]

**BALL & ROLLER
BEARINGS**

CAT. NO. B2001E-3



Publication of Rolling Bearing Catalog

Today's technology-based society, in order to utilize the earth's limited resources effectively and protect the environment, must strive to develop new technologies and alternate energy sources, and in that connection it continues to pursue new targets in various fields. To achieve such targets, technically advanced and highly functional rolling bearings with significantly greater compactness, lighter weight, longer life and lower friction as well as higher reliability during use in special environments are sought.

This new-edition catalog is based on the results of wide-ranging technical studies and extensive R&D efforts and will enable the reader to select the optimal bearing for each application. In addition to standard bearings, this catalog provides information on a variety of bearings for specific purposes, such as ball bearing units, plummer blocks, and JTEKT EXSEV bearing series (bearings for extreme special environments).

JTEKT is confident that you will find this new catalog useful in the selection and use of rolling bearings. JTEKT is grateful for your patronage and look forward to continuing to serve you in the future.

★The contents of this catalog are subject to change without prior notice. Every possible effort has been made to ensure that the data herein is correct; however, JTEKT cannot assume responsibility for any errors or omissions.

Reproduction of this catalog without written consent is strictly prohibited

Contents

Technical section

1 Rolling bearing structures and types

- 1-1 Structure A 1
- 1-2 Type A 1

2 Outline of bearing selection A 14

3 Selection of bearing type A 16

4 Selection of bearing arrangement A 20

5 Selection of bearing dimensions

- 5-1 Bearing service life A 24
- 5-2 Calculation of service life A 24
- 5-3 Calculation of loads A 29
- 5-4 Dynamic equivalent load..... A 34
- 5-5 Basic static load rating and static equivalent load A 38
- 5-6 Allowable axial load for cylindrical roller bearings A 40
- 5-7 Applied calculation examples .. A 41

6 Boundary dimensions and bearing numbers

- 6-1 Boundary dimensions A 46
- 6-2 Dimensions of snap ring grooves and locating snap rings..... A 47
- 6-3 Bearing number A 48

7 Bearing tolerances

- 7-1 Tolerances and tolerance classes for bearings..... A 52
- 7-2 Tolerance measuring method.. A 74

8 Limiting speed

- 8-1 Correction of limiting speed..... A 78
- 8-2 Limiting speed for sealed ball bearings..... A 79
- 8-3 Considerations for high speed A 79
- 8-4 Frictional coefficient (refer.)..... A 79

9 Bearing fits

- 9-1 Purpose of fit..... A 80
- 9-2 Tolerance and fit for shaft & housing A 80
- 9-3 Fit selection..... A 81
- 9-4 Recommended fits A 84

10 Bearing internal clearance

- 10-1 Selection of internal clearance A 93
- 10-2 Operating clearance..... A 94

11 Preload

- 11-1 Purpose of preload..... A 106
- 11-2 Method of preloading A 106
- 11-3 Preload and rigidity A 107
- 11-4 Amount of preload A 108

12 Bearing lubrication

- 12-1 Purpose and method of lubrication A 111
- 12-2 Lubricant A 118

13 Bearing materials

- 13-1 Bearing rings and rolling elements materials A 122
- 13-2 Materials used for cages A 124

14 Shaft and housing design

- 14-1 Accuracy and roughness of shafts and housings A 125
- 14-2 Mounting dimensions A 126
- 14-3 Shaft design A 128
- 14-4 Sealing devices A 129

15 Handling of bearings

- 15-1 General instructions A 133
- 15-2 Storage of bearings A 133
- 15-3 Bearing mounting A 133
- 15-4 Test run A 138
- 15-5 Bearing dismounting A 140
- 15-6 Maintenance and inspection of bearings A 142
- 15-7 Methods of analyzing bearing failures A 143

16 Examples of bearing failures A 144

Specification tables Contents B 2

[Standard bearings]

- Deep groove ball bearings B 4
- Angular contact ball bearings B 52
- Self-aligning ball bearings B 134
- Cylindrical roller bearings B 154
- Tapered roller bearings B 200
- Spherical roller bearings B 302
- Thrust ball bearings B 348

- Spherical thrust roller bearings B 366
- Needle roller bearings B 374
- Ball bearing units B 462
- Plummer blocks B 540

[Special purpose bearings]

- Ceramic & EXSEV bearing series C 1
- K-series super thin section ball bearings C 27
- Bearings for machine tool spindles (for support of axial loading) C 47
- Precision ball screw support bearings and bearing units C 65
- Full complement type cylindrical roller bearings for crane sheaves C 71
- Rolling mill roll neck bearings C 81
- Bearings for railway rolling stock axle journals C 139
- Linear ball bearings C 149
- Locknuts, lockwashers & lock plates C 163

Supplementary tables

- 1 Boundary dimensions of radial bearings D 1
- 2 Boundary dimensions of tapered roller bearings D 5
- 3 Boundary dimensions of single direction thrust bearings D 7
- 4 Boundary dimensions of double direction thrust ball bearings D 9
- 5 Dimension of snap ring grooves and locating snap rings D 11
- 6 Shaft tolerances D 15
- 7 Housing bore tolerances D 17
- 8 Numerical values for standard tolerance grades IT D 19
- 9 Greek alphabet list D 20
- 10 Prefixes used with SI units D 20
- 11 SI units and conversion factors D 21
- 12 Inch/millimeter conversion D 25
- 13 Steel hardness conversion D 26
- 14 Surface roughness comparison D 27
- 15 Viscosity conversion D 28

1. Rolling bearing structures and types

1-1 Structure

Rolling bearings (bearings hereinafter) normally comprise bearing rings, rolling elements and a cage. (see Fig. 1-1)

Rolling elements are arranged between inner and outer rings with a cage, which retains the rolling elements in correct relative position, so they do not touch one another. With this structure, a smooth rolling motion is realized during operation.

Bearings are classified as follows, by the number of rows of rolling elements : single-row, double-row, or multi-row (triple- or four-row) bearings.

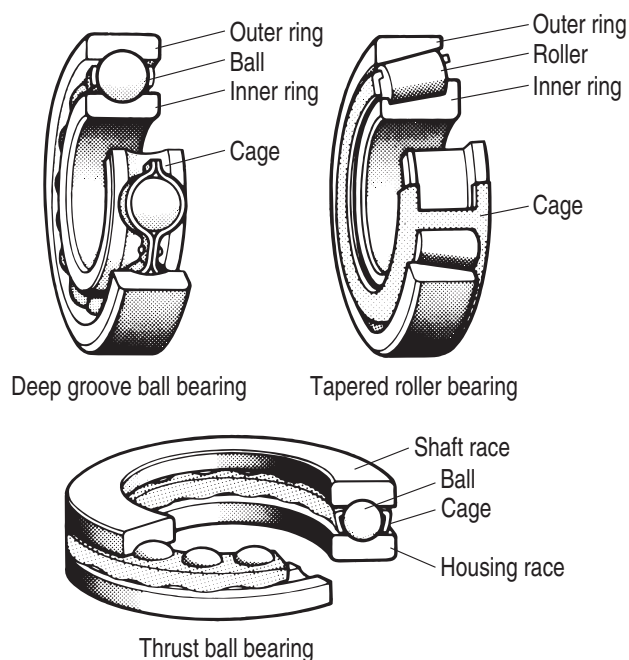

Note) In thrust bearings inner and outer rings and also called "shaft race" and "housing race" respectively. The race indicates the washer specified in JIS.

Fig. 1-1 Bearing structure

1) Bearing rings

The path of the rolling elements is called the raceway; and, the section of the bearing rings where the elements roll is called the raceway surface. In the case of ball bearings, since grooves are provided for the balls, they are also referred to as raceway grooves.

The inner ring is normally engaged with a shaft; and, the outer ring with a housing.

2) Rolling element

Rolling elements may be either balls or rollers. Many types of bearings with various shapes of rollers are available.

- Ball
- Cylindrical roller ($L_W \leq 3 D_W$)*
- ▬ Long cylindrical roller ($3D_W \leq L_W \leq 10D_W, D_W > 6 \text{ mm}$)*
- ▬ Needle roller ($3D_W \leq L_W \leq 10D_W, D_W \leq 6 \text{ mm}$)*
- ▭ Tapered roller (tapered trapezoid)
- ▭ Convex roller (barrel shape)

* $\begin{cases} L_W : \text{roller length (mm)} \\ D_W : \text{roller diameter (mm)} \end{cases}$

3) Cage

The cage guides the rolling elements along the bearing rings, retaining the rolling elements in correct relative position. There are various types of cages including pressed, machined, molded, and pin type cages.

Due to lower friction resistance than that found in full complement roller and ball bearings, bearings with a cage are more suitable for use under high speed rotation.

1-2 Type

The contact angle (α) is the angle formed by the direction of the load applied to the bearing rings and rolling elements, and a plan perpendicular to the shaft center, when the bearing is loaded.

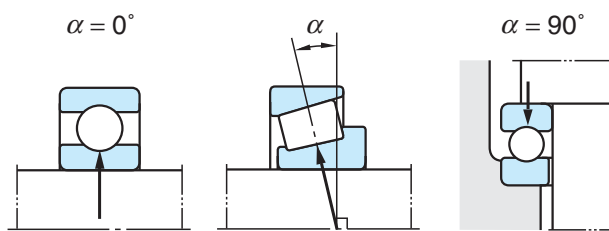

Bearings are classified into two types in accordance with the contact angle (α).

- Radial bearings ($0^\circ \leq \alpha \leq 45^\circ$)
... designed to accommodate mainly radial load.
- Thrust bearings ($45^\circ < \alpha \leq 90^\circ$)
... designed to accommodate mainly axial load.

Rolling bearings are classified in Fig. 1-2, and characteristics of each bearing type are described in Tables 1-1 to 1-13.

1. Rolling bearing structures and types

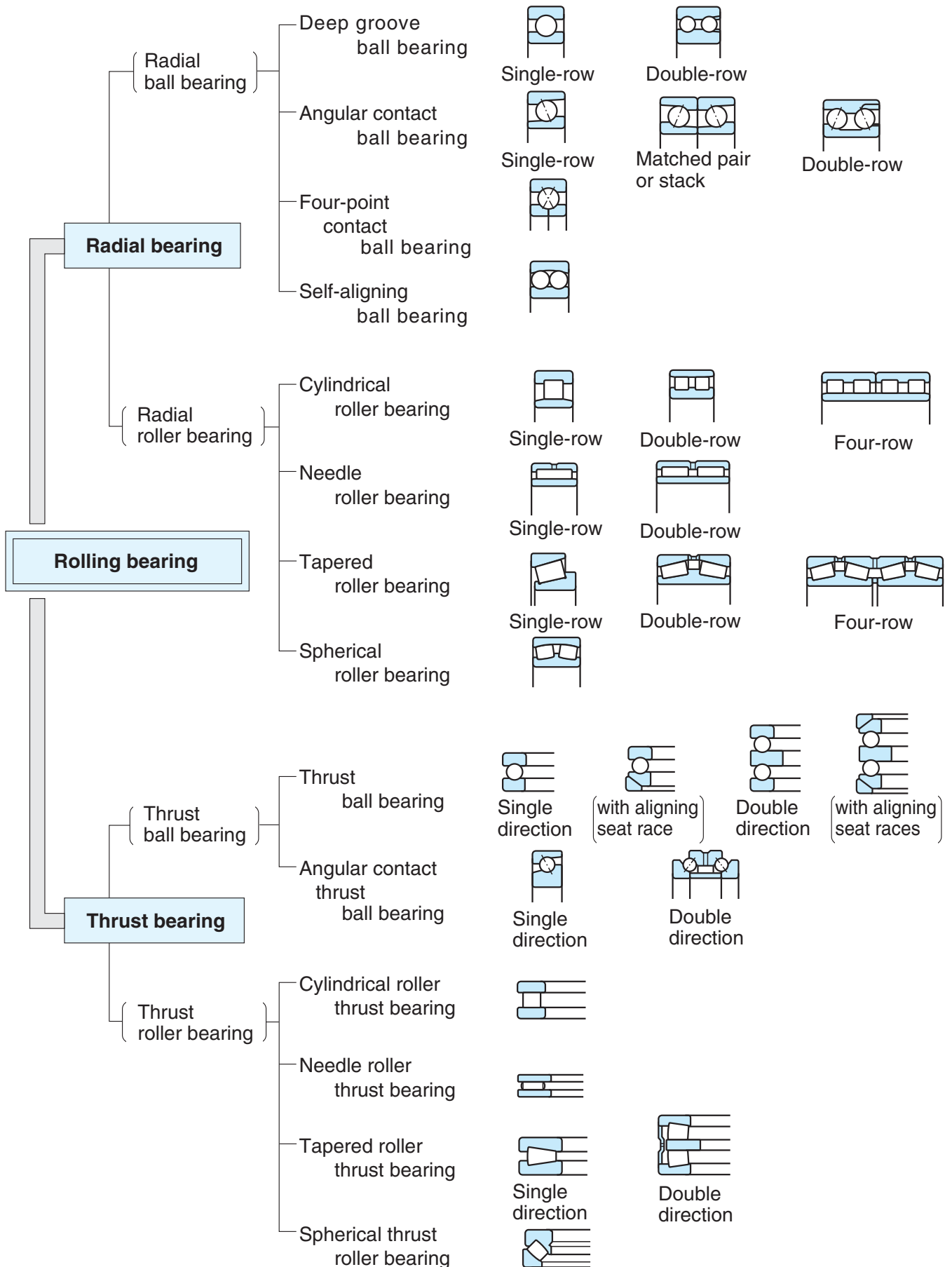
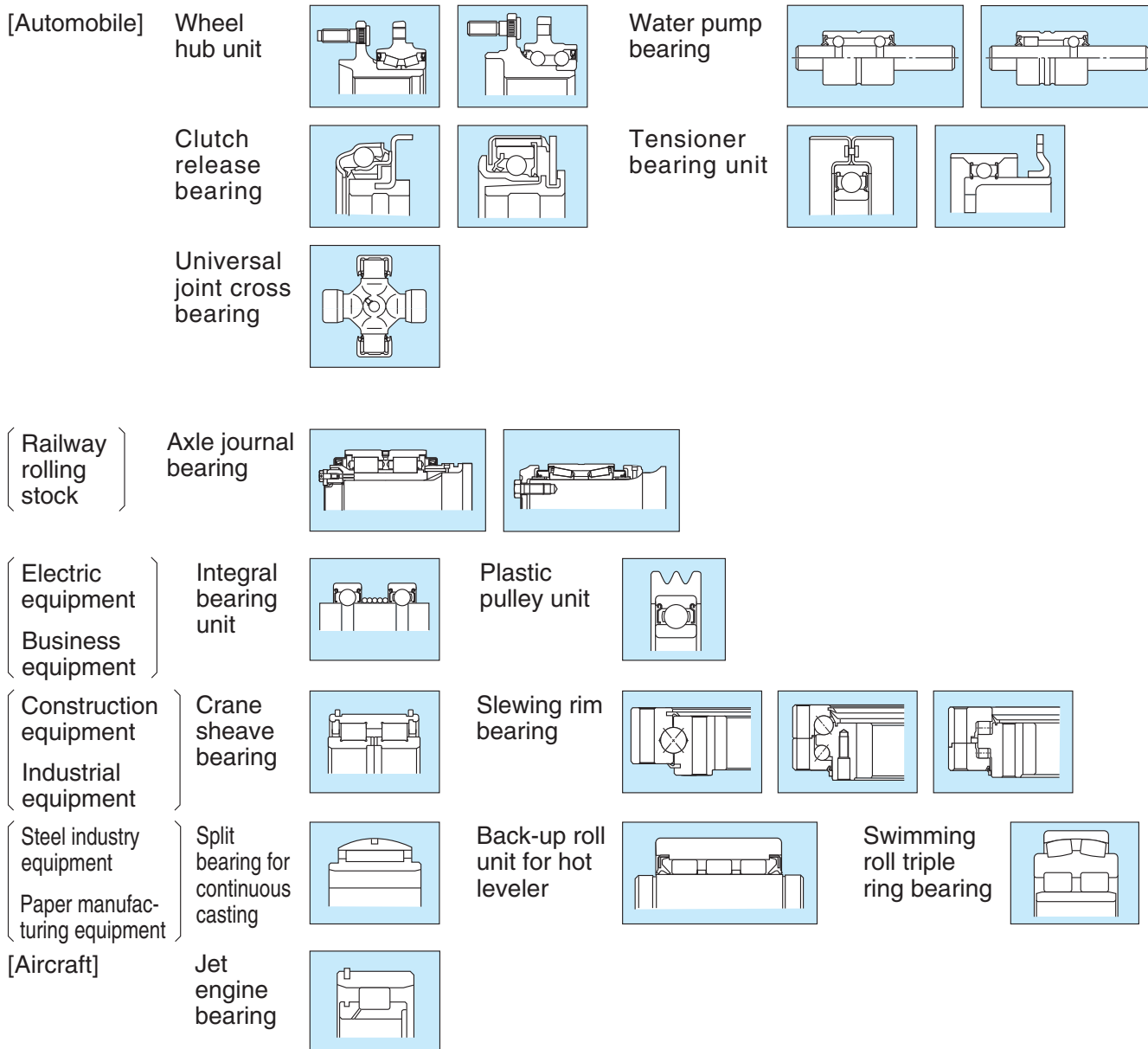

Fig. 1-2(1) Rolling bearings

Bearings classified by use



Others

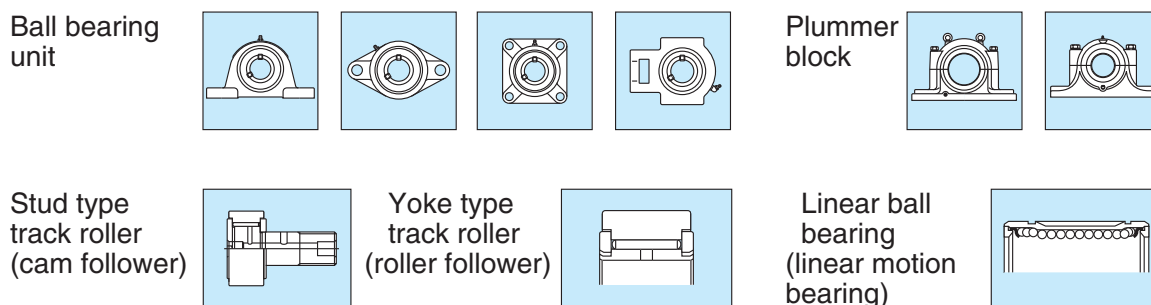
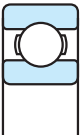





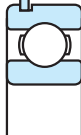



Fig. 1-2(2) Rolling bearings

Table 1-1 Deep groove ball bearings

Single-row							Double-row	
Open type	Shielded type	Non-contact sealed type	Contact sealed type		Extremely light contact sealed type	With locating snap ring	Flanged type	
								
	ZZ	2RU	2RS	2RK	2RD	NR	[Suitable for extra-small or miniature bearing]	
680, 690, 6800, 6900, 16000		600, 620, 630, (ML)	…Extra-small, miniature bearing					4200 4300

- The most popular types among rolling bearings, widely used in a variety of industries.
- Radial load and axial load in both directions can be accommodated.
- Suitable for operation at high speed, with low noise and low vibration.
- Sealed bearings employing steel shields or rubber seals are filled with the appropriate volume of grease when manufactured.
- Bearings with a flange or locating snap ring attached on the outer ring are easily mounted in housings for simple positioning of housing location.

[Recommended cages] Pressed steel cage (ribbon type, snap type … single-row, S type … double-row), copper alloy or phenolic resin machined cage, synthetic resin molded cage

[Main applications] Automobile : front and rear wheels, transmissions, electric devices
 Electric equipment : standard motors, electric appliances for domestic use
 Others : measuring instruments, internal combustion engines, construction equipment, railway rolling stock, cargo transport equipment, agricultural equipment, equipment for other industrial uses

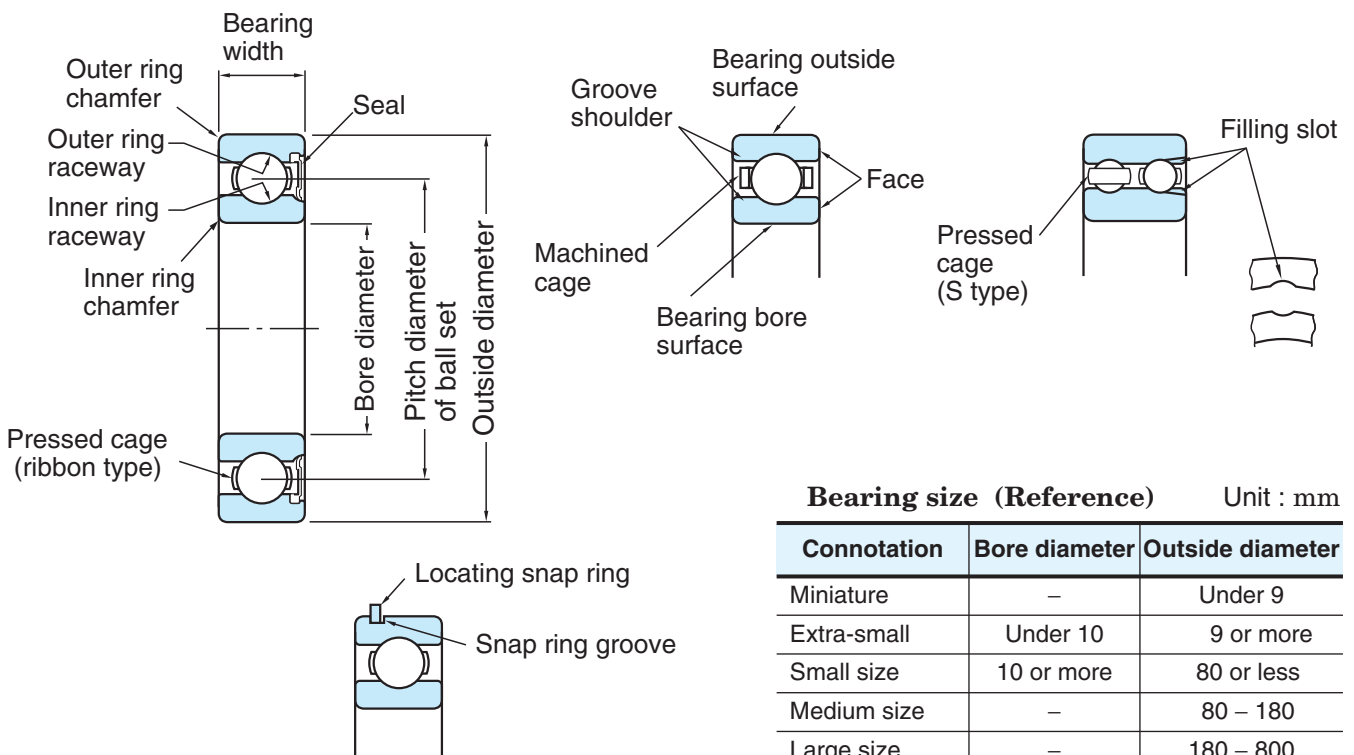

Bearing size (Reference)		Unit : mm
Connotation	Bore diameter	Outside diameter
Miniature	–	Under 9
Extra-small	Under 10	9 or more
Small size	10 or more	80 or less
Medium size	–	80 – 180
Large size	–	180 – 800
Extra-large size	–	Over 800

Table 1-2 Angular contact ball bearings

Single-row			Matched pair			Double-row	
		For high-speed use HAR					
(With pressed cage)	(With machined cage)		DB	DF	DT	(With filling slot)	
7000, 7200, 7300, 7400					3200	5200
7000B, 7200B, 7300B, 7400B					3300	5300
7900C, 7000C, 7200C, 7300C			}			Contact angle 32°	Contact angle 24°
HAR900C, HAR000C							

- Bearing rings and balls possess their own contact angle which is normally 15°, 30° or 40°.
 - (Larger contact angle higher resistance against axial load)
 - (Smaller contact angle more advantageous for high-speed rotation)
- Single-row bearings can accommodate radial load and axial load in one direction.
- DB and DF matched pair bearings and double-row bearings can accommodate radial load and axial load in both directions.
DT matched pair bearings are used for applications where axial load in one direction is too large for one bearing to accept.
- HAR type high speed bearings were designed to contain more balls than standard bearings by minimizing the ball diameter, to offer improved performance in machine tools.
- Angular contact ball bearings are used for high accuracy and high-speed operation.

- Axial load in both directions and radial load can be accommodated by adapting a structure pairing two single-row angular contact ball bearings back to back.
- For bearings with no filling slot, the sealed type is available.

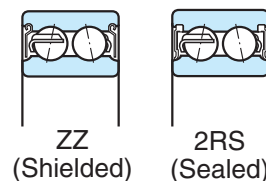

[Recommended cages] Pressed steel cage (conical type ... single-row : S type, snap type ... double-row), copper alloy or phenolic resin machined cage, synthetic resin molded cage

[Main applications] Single-row : machine tool spindles, high frequency motors, gas turbines, centrifugal separators, front wheels of small size automobiles, differential pinion shafts
Double-row : hydraulic pumps, roots blowers, air-compressors, transmissions, fuel injection pumps, printing equipment

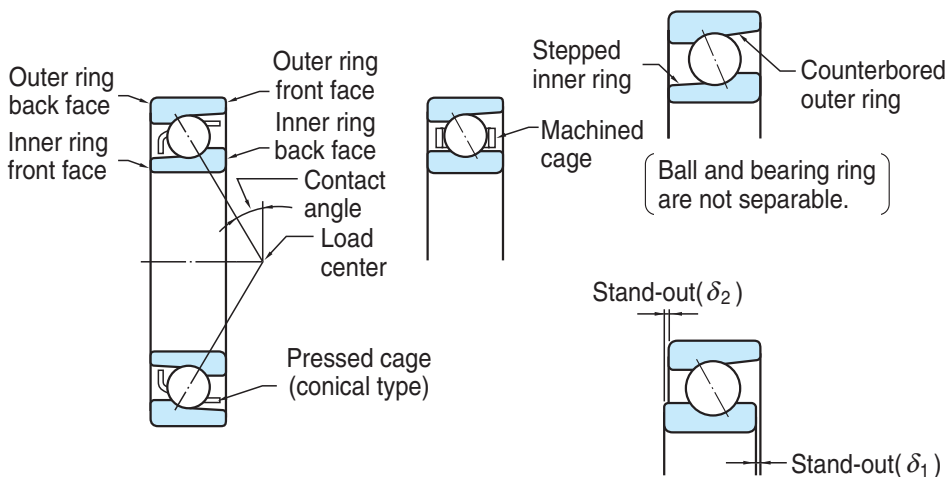

Contact angles (Reference)

Contact angle	Supplementary code
15°	C
20°	CA
25°	AC
30°	A (Omitted)
35°	E
40°	B

"G type" bearings are processed (with flush ground) such that the stand-out turns out to be $\delta_1 = \delta_2$. The matched pair DB, DF, and DT, or stack are available.

Table 1-3 Four-point contact ball bearings

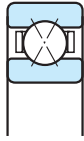
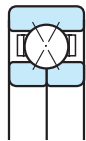
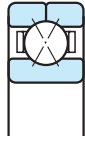
One-piece type	Two-piece inner ring	Two-piece outer ring
		
—	6200BI 6300BI	(6200BO) (6300BO)



- Radial load and axial load in both directions can be accommodated.
- A four-point contact ball bearing can substitute for a face-to-face or back-to-back arrangement of angular contact ball bearings.
- Suitable for use under pure axial load or combined radial and axial load with heavy axial load.
- This type of bearing possesses a contact angle (α) determined in accordance with the axial load direction. This means that the bearing ring and balls contact each other at two points on the lines forming the contact angle.

[Recommended cage] Copper alloy machined cage

[Main applications]

Motorcycle : Transmission, driveshaft pinion-side
Automobile : Steering, transmission

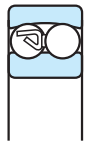
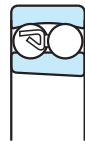
Table 1-4 Self-aligning ball bearings

Cylindrical bore	Tapered bore	Sealed
	 K (Taper 1 : 12)	 2RS
120, 130 1200, 1300 2200, 2300	(11200, 11300... extended inner ring type)	2200 2RS 2300 2RS

- Spherical outer ring raceway allows self-alignment, accommodating shaft or housing deflection and misaligned mounting conditions.
- Tapered bore design can be mounted readily using an adapter.

Pressed steel cage (staggered type...12, 13,
22...2RS, 23...2RS)
snap type.....22, 23

Power transmission shaft of wood working and spinning machines, plummer blocks

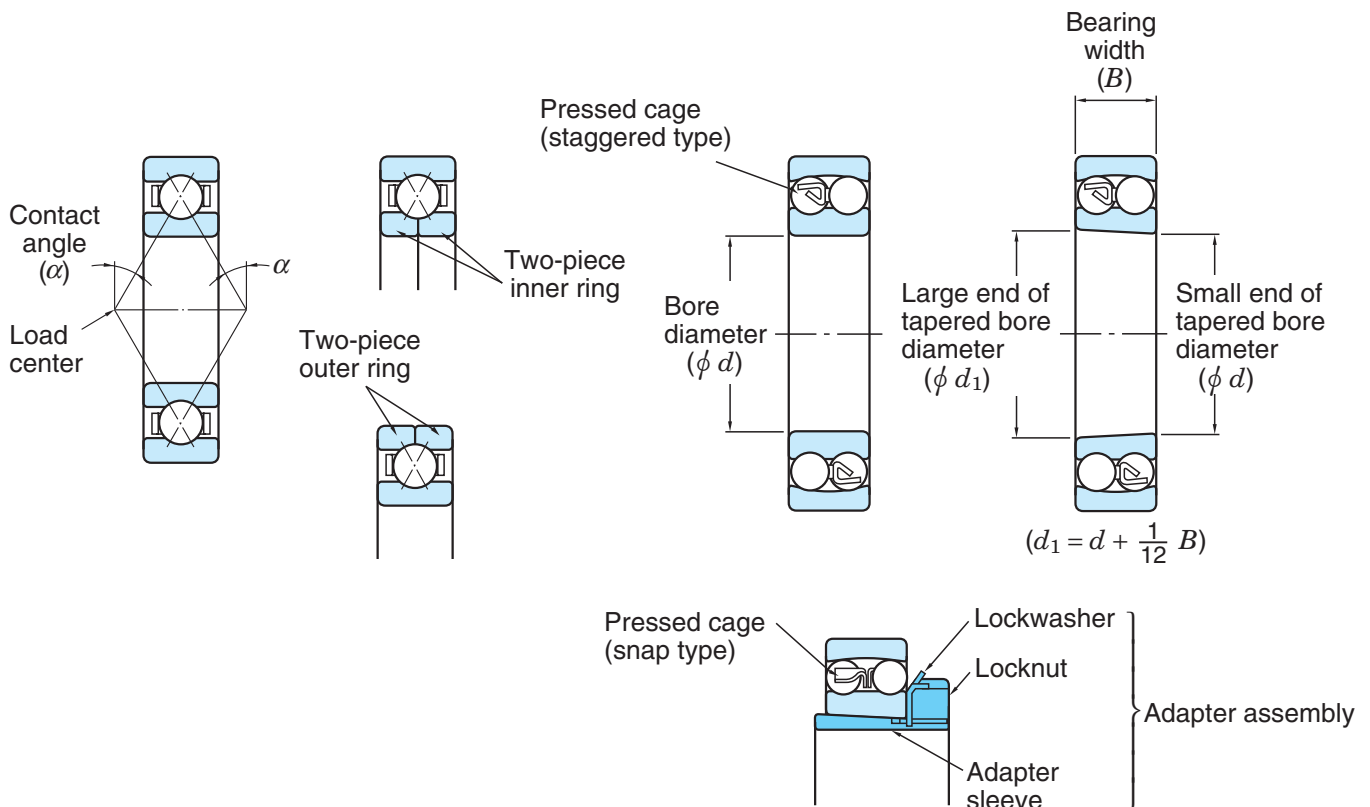

Table 1-5 Cylindrical roller bearings

Single-row						Double-row		Four-row
NU	NJ	NUP	N	NF	NH	NN	NNU	(Mainly use on rolling mill roll neck)
NU1000, NU200 (R), NU300 (R), NU400 NU2200 (R), NU2300 (R) NU3200, NU3300						Cylindrical bore NN4900 NN3000	Tapered bore NNU4900K NN3000K	(FC), (4CR)

- Since the design allowing linear contact of cylindrical rollers with the raceway provides strong resistance to radial load, this type is suitable for use under heavy radial load and impact load, as well as at high speed.
- N and NU types are ideal for use on the free side: they are movable in the shaft direction in response to changes in bearing position relative to the shaft or housing, which are caused by heat expansion of the shaft or improper mounting.
- NJ and NF types can accommodate axial load in one direction; and NH and NUP types can accommodate partial axial load in both directions.
- With separable inner and outer ring, this type ensures easy mounting.
- Due to their high rigidity, NNU and NN types are widely used in machine tool spindles.

[Recommended cages] Pressed steel cage (Z type), copper alloy machined cage, pin type cage, synthetic resin molded cage

[Main applications] Large and medium size motors, traction motors, generators, internal combustion engines, gas turbines, machine tool spindles, speed reducers, cargo transport equipment, and other industrial equipment

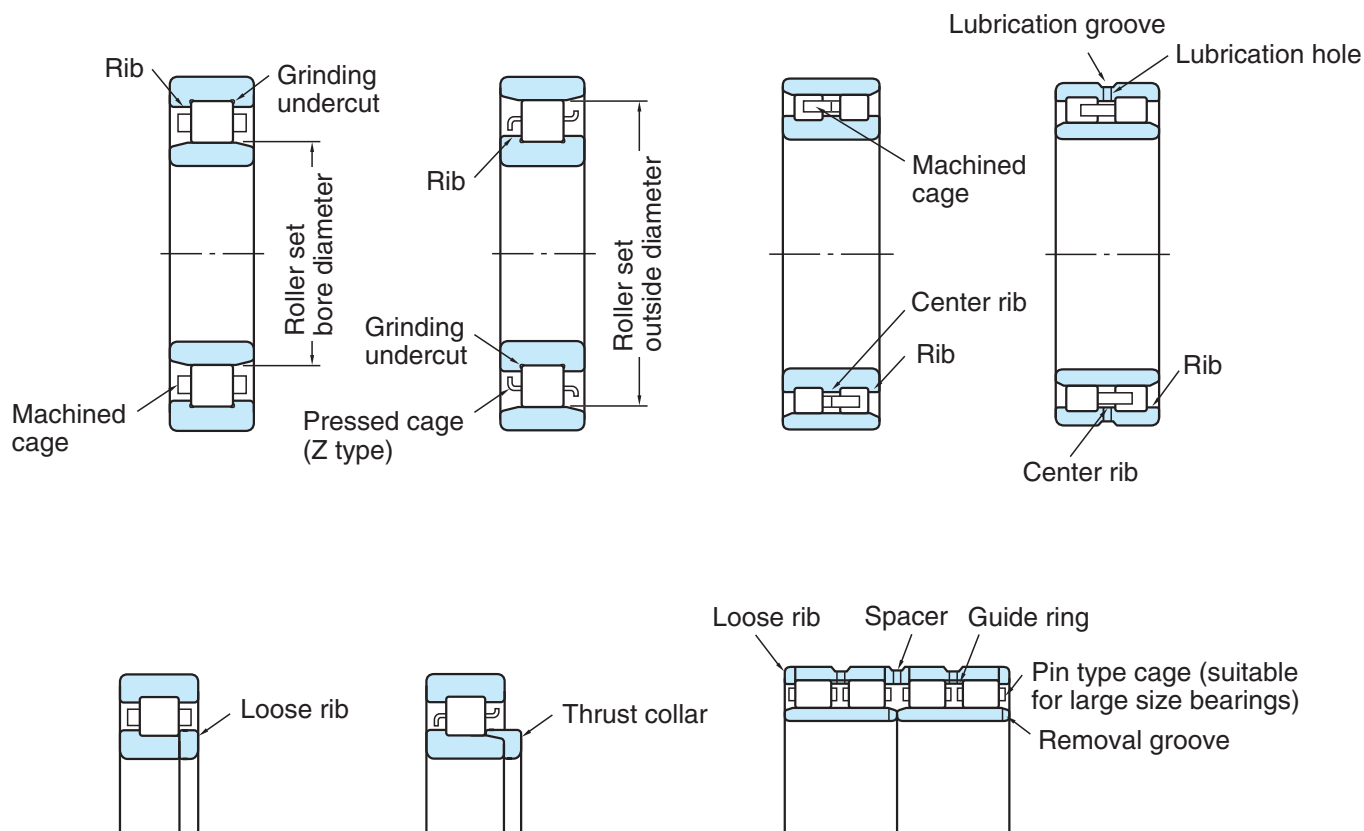
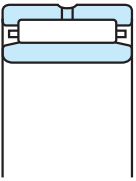
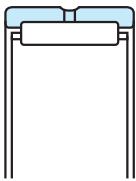
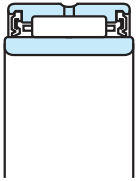
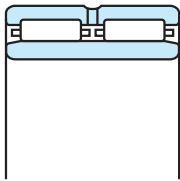
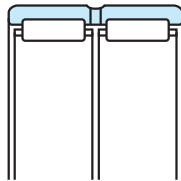

Table 1-6 Machined ring needle roller bearings

Single-row			Double-row	
				
With inner ring	Without inner ring	Sealed	With inner ring	Without inner ring
NA4800 NA4900 NA5900 (NQI, NQIS)	RNA4800 RNA4900 RNA5900 (NQ, NQS)	– NA4900UU –	NA6900	RNA6900

- In spite of their basic structure, which is the same as that of NU type cylindrical roller bearings, bearings with minimum ring sections offer space savings and greater resistance to radial load, by using needle rollers.
- Bearings with no inner rings function using heat treated and ground shafts as their raceway surface.

[Recommended cage] Pressed steel cage

[Main applications] Automobile engines, transmissions, pumps, power shovel wheel drums, hoists, overhead traveling cranes, compressors

(Reference) Many needle roller bearings other than those with machined ring are available. For further details, refer to the section, "needle roller bearing specification table".

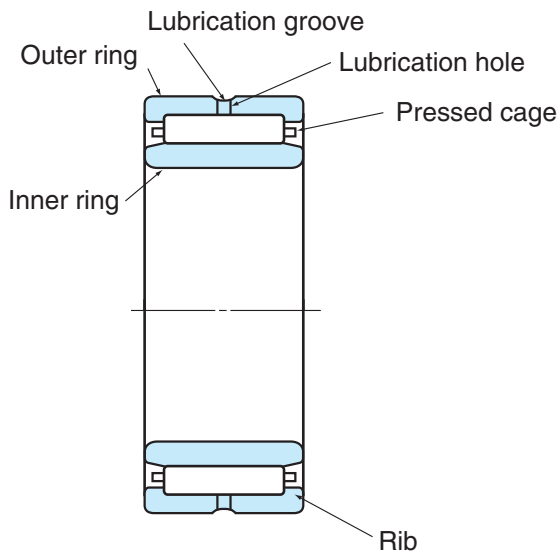

Needle roller and cage assemblies

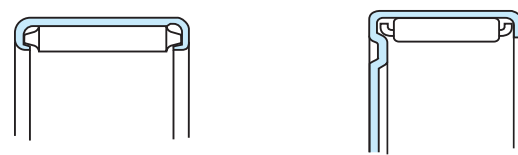

Drawn cup needle roller bearings

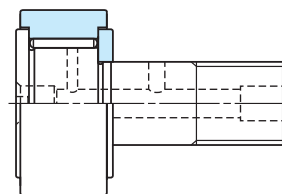

Stud type track roller (cam follower)

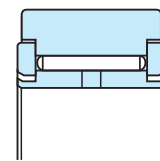

Yoke type track roller (roller follower)

Table 1-7 Tapered roller bearings

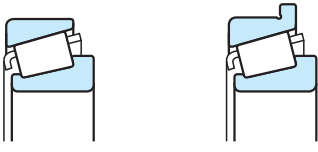
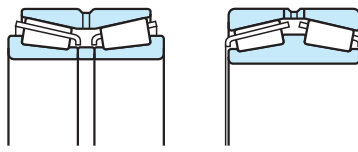
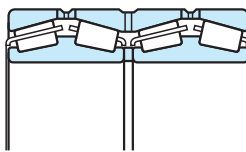
Single-row				Double-row		Four-row
 <p style="text-align: center;">Flanged type</p>				 <p style="text-align: center;">TDO type TDI type</p>		 <p style="text-align: center;">(Mainly used on rolling mill roll necks)</p>
(Standard contact angle)	(Intermediate contact angle)	(Steep contact angle)				
32900JR	30200JR	30200CR	30300DJ	46200	45200	37200
32000JR	32200JR	32200CR	30300DJR	46200A	45300	47200
33000JR	33200JR	30300CR	31300JR	46300	(45T)	47300
33100JR	30300JR	32300CR		46300A	(46T)	(47T)
	32300JR					(4TR)

- Tapered rollers assembled in the bearings are guided by the inner ring back face rib.
- The raceway surfaces of inner ring and outer ring and the rolling contact surface of rollers are designed so that the respective apexes converge at a point on the bearing center line.
- Single-row bearings can accommodate radial load and axial load in one direction, and double-row bearings can accommodate radial load and axial load in both directions.
- This type of bearing is suitable for use under heavy load or impact load.
- Bearings are classified into standard, intermediate and steep types, in accordance with their contact angle (α). The larger the contact angle is, the greater the bearing resistance to axial load.
- Since outer ring and inner ring assembly can be separated from each other, mounting is easy.
- Bearings designated by the suffix "J" and "JR" are interchangeable internationally.
- Items sized in inches are still widely used.

[Recommended cages] Pressed steel cage, synthetic resin molded cage, pin type cage

[Main applications] Automobile : front and rear wheels, transmissions, differential pinion

Others : machine tool spindles, construction equipment, large size agricultural equipment, railway rolling stock speed reduction gears, rolling mill roll necks and speed reducers, etc

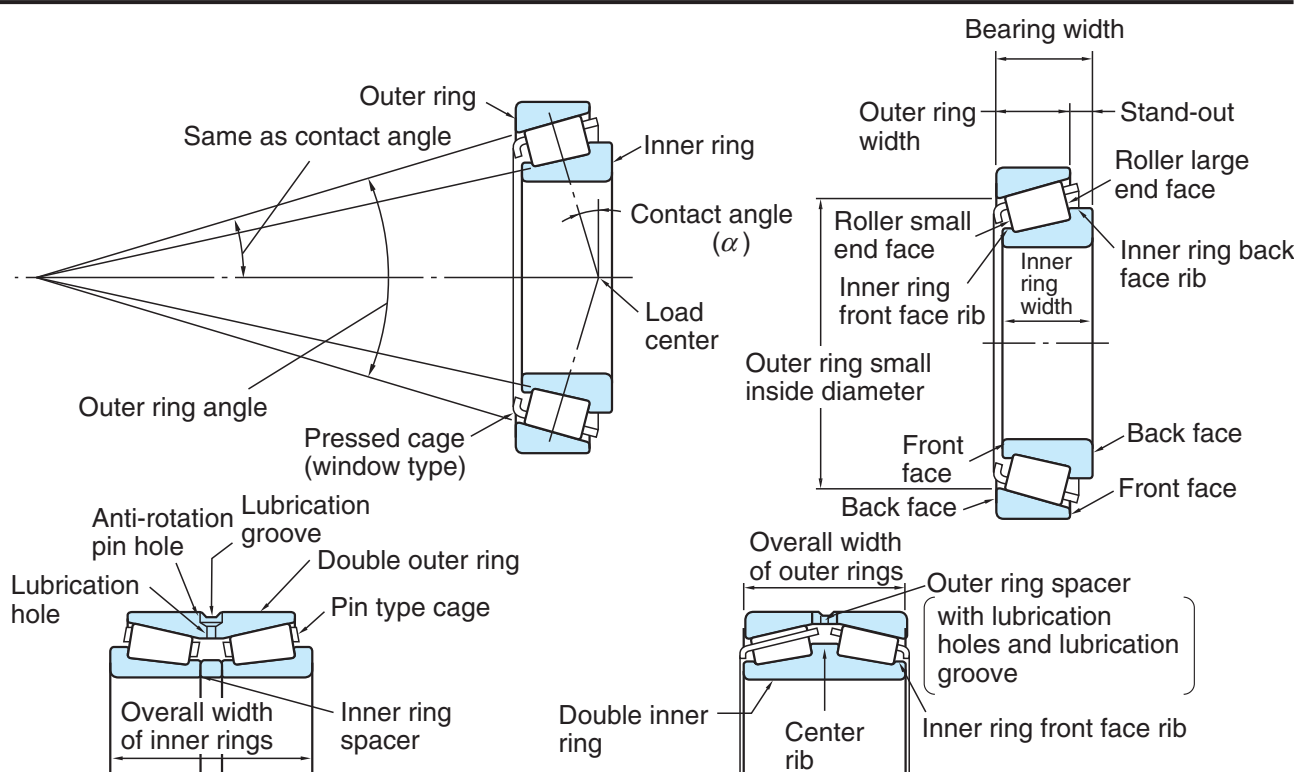
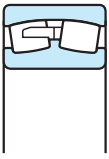



Table 1-8 Spherical roller bearings

Cylindrical bore		Tapered bore
Convex asymmetrical roller type	Convex symmetrical roller type	
		
R, RR	RH, RHR	RHA
23900R, 23000R (RH, RHA), 23100R (RH, RHA), 22200R (RH, RHA), 21300R (RH) 24000R (RH, RHA), 24100R (RH, RHA), 23200R (RH, RHA), 22300R (RH, RHA)		

- Spherical roller bearings comprising barrel-shaped convex rollers, double-row inner ring and outer ring are classified into three types : R(RR), RH(RHR) and RHA, according to their internal structure.
- With the bearing designed such that the circular arc center of the outer ring raceway matches with the bearing center, the bearing is self-aligning, insensitive to errors of alignment of the shaft relative to the housing, and to shaft bending.
- This type can accommodate radial load and axial load in both directions, which makes it especially suitable for applications in which heavy load or impact load is applied.
- The tapered bore type can be easily mounted/dismounted by using an adapter or withdrawal sleeve. There are two types of tapered bores (tapered ratio) :
 - 1 : 30 (supplementary code K30) ... Suitable for series 240 and 241.
 - 1 : 12 (supplementary code K) ... Suitable for series other than 240 and 241.
- Lubrication holes, a lubrication groove and anti-rotation pin hole can be provided on the outer ring. Lubrication holes and a lubrication groove can be provided on the inner ring, too.

[Recommended cages] Copper alloy machined cage, pressed steel cage, pin type cage

[Main applications] Paper manufacturing equipment, speed reducers, railway rolling stock axle journals, rolling mill pinion stands, table rollers, crushers, shaker screens, printing equipment, wood working equipment, speed reducers for various industrial uses, plummer blocks

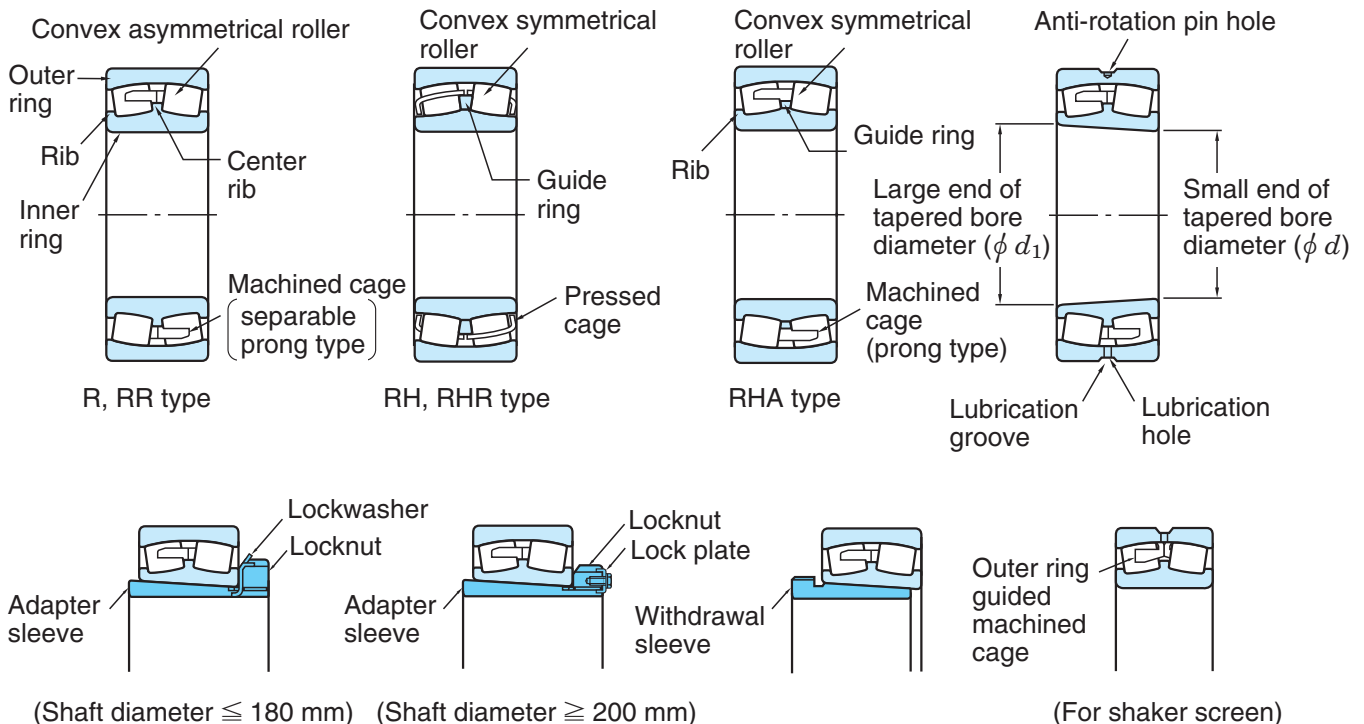
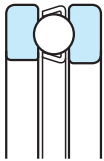
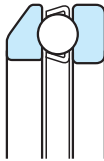
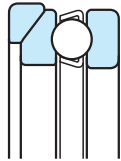
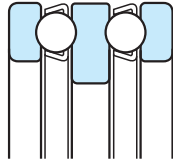
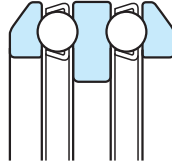
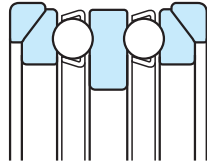

Table 1-9 Thrust ball bearings

Single direction			Double direction		
With flat back faces	With spherical back face	With aligning seat race	With flat back faces	With spherical back faces	With aligning seat races
					
51100 51200 51300 51400	— 53200 53300 53400	— 53200U 53300U 53400U	— 52200 52300 52400	— 54200 54300 54400	— 54200U 54300U 54400U

- This type of bearing comprises washer-shaped rings with raceway groove and ball and cage assembly.
- Races to be mounted on shafts are called shaft races (or inner rings); and, races to be mounted into housings are housing races (or outer rings). Central races of double direction bearings are mounted on the shafts.
- Single direction bearings accommodate axial load in one direction, and double direction bearings accommodate axial load in both directions. (Both of these bearings cannot accommodate radial loads.)
- Since bearings with a spherical back face are self-aligning, it helps to compensate for mounting errors.

[Recommended cages] Pressed steel cage, copper alloy or phenolic resin machined cage, synthetic resin molded cage

[Main applications] Automobile king pins, machine tool spindles

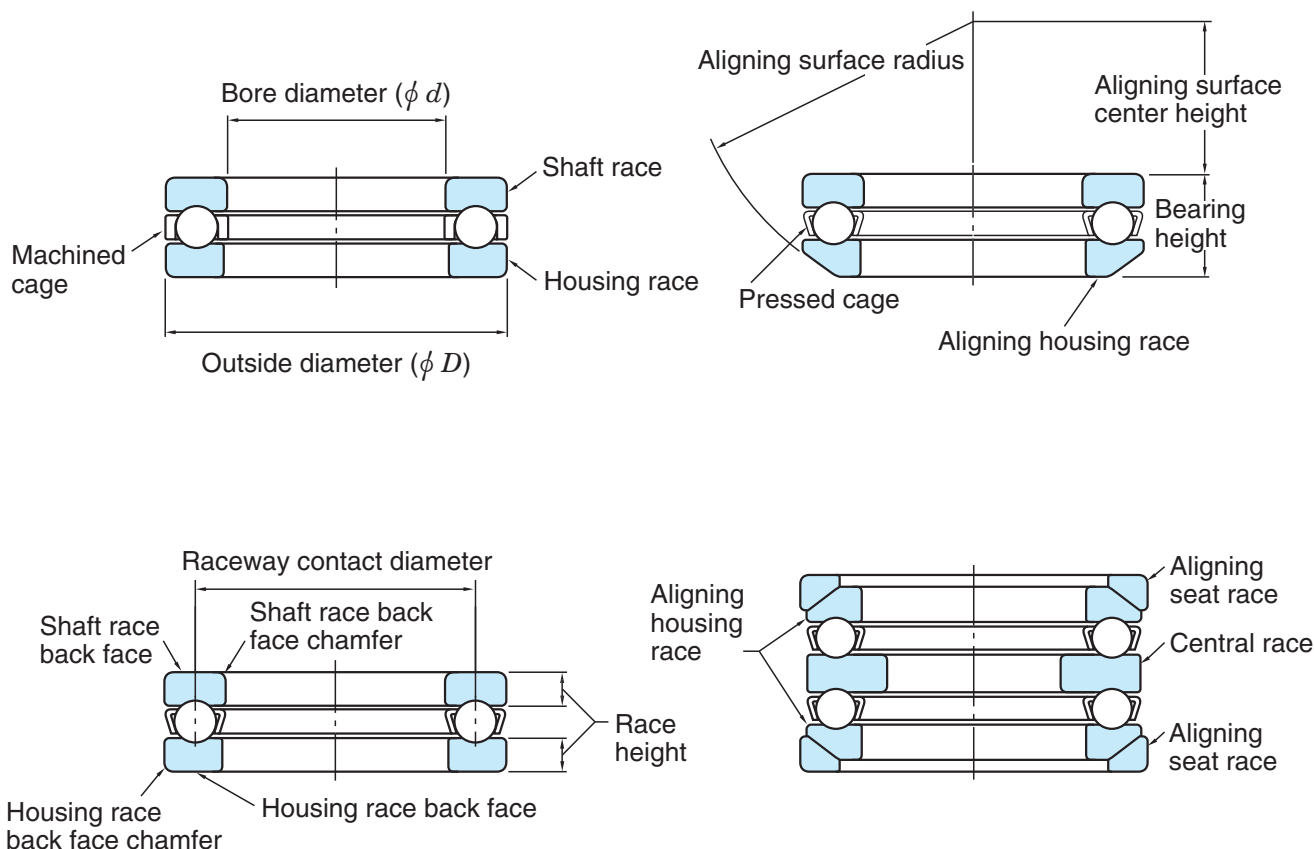

[Remark] The race indicates the washer specified in JIS.

Table 1-10 Cylindrical roller thrust bearings

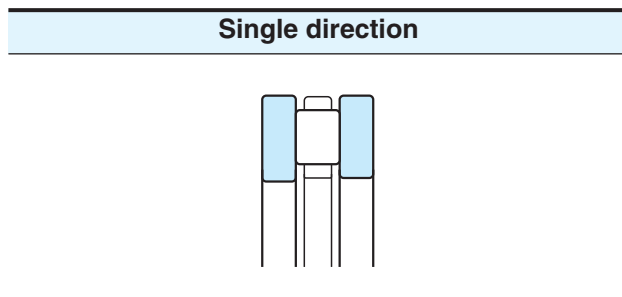

(THR.....R)

- This type of bearing comprises washer-shaped rings (shaft and housing race) and cylindrical roller and cage assembly.
Crowned cylindrical rollers produce uniform pressure distribution on roller/raceway contact surface.
- Axial load can be accommodated in one direction.
- Great axial load resistance and high axial rigidity are provided.

[Recommended cages] Copper alloy machined cage

[Main applications] Oil excavators, iron and steel equipment

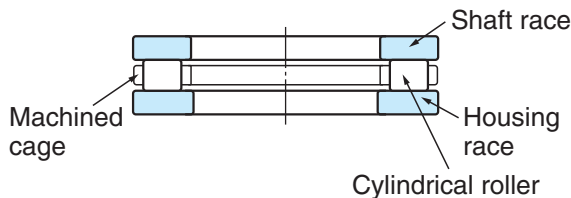
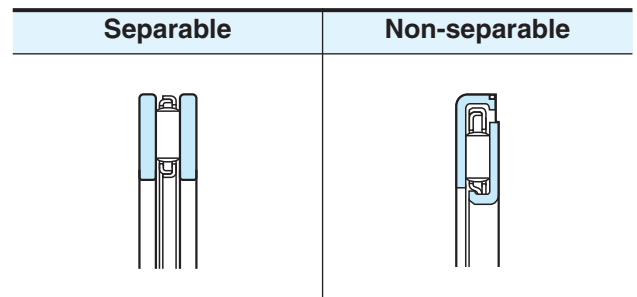

Table 1-11 Needle roller thrust bearings



(TPW)
(TPWS)
(TPWWS)

(TPK)
(TVK)

- The separable type, comprising needle roller and cage thrust assembly and a race, can be matched with a pressed thin race (W) or machined thick race (WS).
- The non-separable type comprises needle roller and cage thrust assembly and a precision pressed race.
- Axial load can be accommodated in one direction.
- Due to the very small installation space required, this type contributes greatly to size reduction of application equipment.
- In many cases, needle roller and cage thrust assembly function by using the mounting surface of the application equipment, including shafts and housings, as its raceway surface.

Pressed steel cage, synthetic resin molded cage

Transmissions for automobiles, cultivators and machine tools

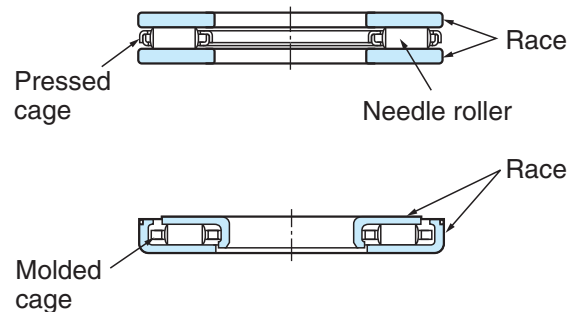

[Remark] The race indicates the thrust washer or washer specified in JIS.

Table 1-12 Tapered roller thrust bearings

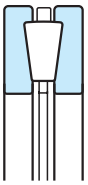
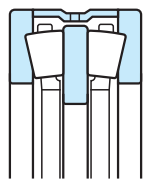
Single direction	Double direction
	
(T) (THR)	(2THR)

- This type of bearing comprises tapered rollers (with spherical large end), which are uniformly guided by ribs of the shaft and housing races.
- Both shaft and housing races and rollers have tapered surfaces whose apexes converge at a point on the bearing axis.
- Single direction bearings can accommodate axial load in one direction; and, double direction bearings can accommodate axial load in both directions.
- Double direction bearings are to be mounted such that their central race is placed on the shaft shoulder. Since this type is treated with a clearance fit, the central race must be fixed with a sleeve, etc.

[Recommended cages] Copper alloy machined cage

[Main applications]

Single direction : crane hooks, oil excavator swivels

Double direction : rolling mill roll necks

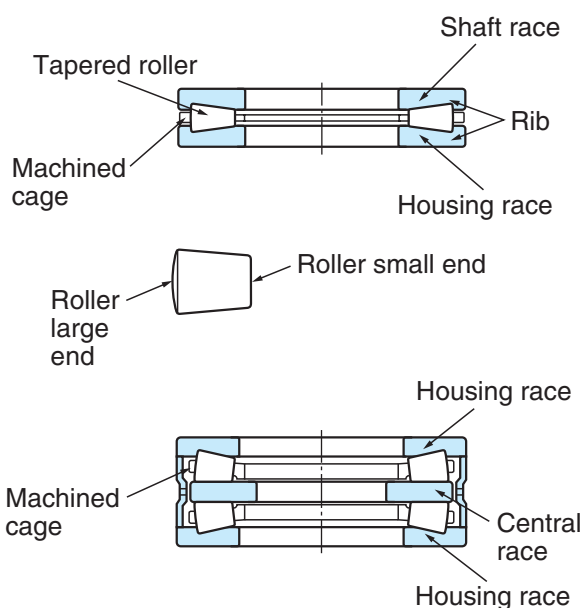
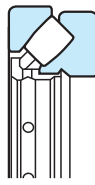

Table 1-13 Spherical thrust roller bearings

29200
29300
29400

- This type of bearing, comprising barrel-shaped convex rollers arranged at an angle with the axis, is self-aligning due to spherical housing race raceway; therefore, shaft inclination can be compensated for to a certain degree.
- Great axial load resistance is provided. This type can accommodate a small amount of radial load as well as heavy axial load.
- Normally, oil lubrication is employed.

Copper alloy machined cage

Hydroelectric generators, vertical motors, propeller shafts for ships, screw down speed reducers, jib cranes, coal mills, pushing machines, molding machines

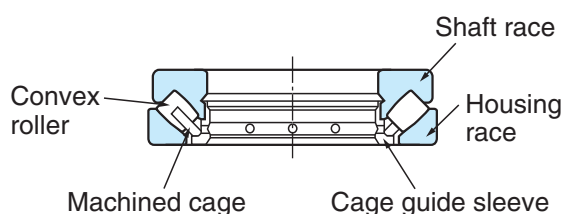

2. Outline of bearing selection

Currently, as bearing design has become diversified, their application range is being increasingly extended. In order to select the most suitable bearings for an application, it is necessary to conduct a comprehensive study on both bearings and the equipment in which the bearings will be installed, including operating conditions, the performance required of the

bearings, specifications of the other components to be installed along with the bearings, marketability, and cost performance, etc.

In selecting bearings, since the shaft diameter is usually determined beforehand, the prospective bearing type is chosen based upon installation space, intended arrangement, and according to the bore diameter required.

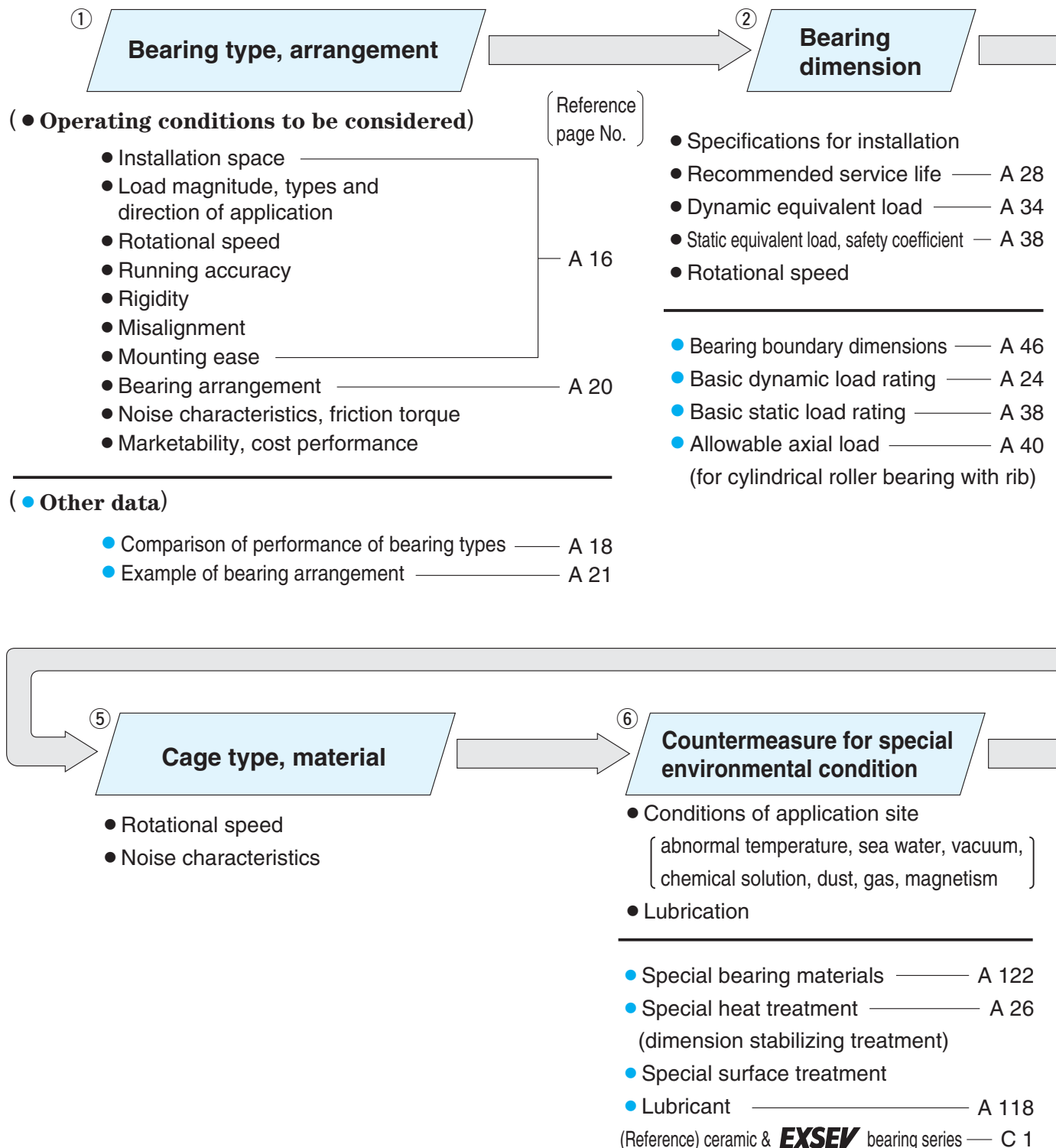

Fig. 2-1(1) Bearing selection procedure

Next, from the bearing specifications are determined the service life required when compared to that of the equipment in which it is used, along with a calculation of the actual service life from operational loads.

Internal specifications including bearing accuracy, internal clearance, cage, and lubricant are also selected, depending on the application.

For reference, general selection procedure and operating conditions are described in Fig. 2-1. There is no need to follow a specific order, since the goal is to select the right bearing to achieve optimum performance.

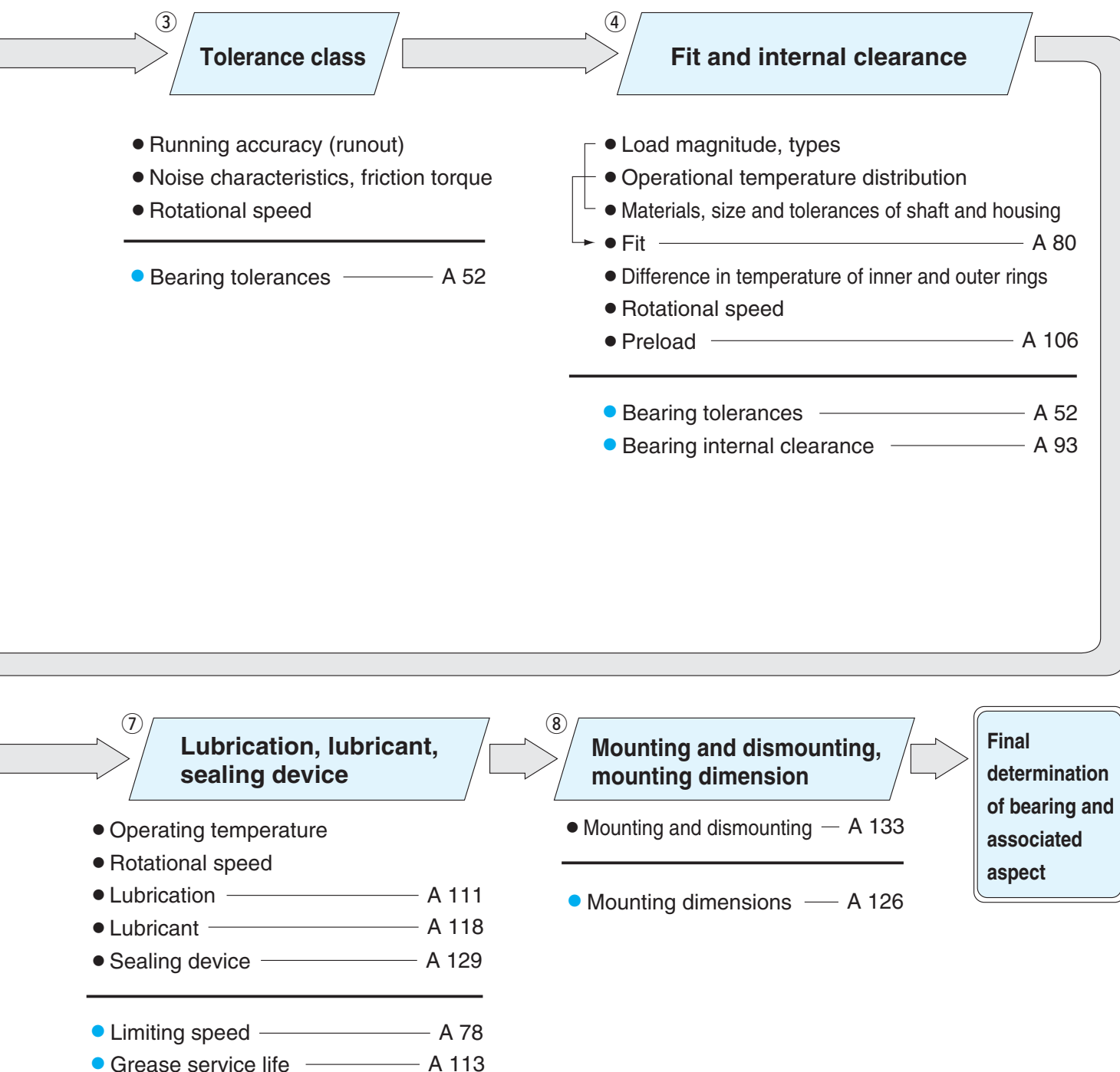

Fig. 2-1(2) Bearing selection procedure

3. Selection of bearing type

In selecting bearings, the most important thing is to fully understand the operating conditions of the bearings.

The main factors to be considered are listed in Table 3-1, while bearing types are listed in Table 3-2.

Table 3-1 (1) Selection of bearing type

Items to be considered		Selection method	Reference page No.
1) Installation space	Bearing can be installed in target equipment	<ul style="list-style-type: none"> When a shaft is designed, its rigidity and strength are considered essential; therefore, the shaft diameter, i.e., bore diameter, is determined at start. For rolling bearings, since wide variety with different dimensions are available, the most suitable bearing type should be selected. (Fig. 3-1) 	A 46
2) Load	Load magnitude, type and direction which applied (Load resistance of bearing is specified in terms of the basic load rating, and its value is specified in the bearing specification table.)	<ul style="list-style-type: none"> Since various types of load are applied to bearings, load magnitude, types (radial or axial) and direction of application (both directions or single direction in the case of axial load), as well as vibration and impact must be considered in order to select the proper bearing. The following is the general order for radial resistance ; (deep groove ball bearings < angular contact ball bearings < cylindrical roller bearings < tapered roller bearings < spherical roller bearings) 	A 18 (Table 3-2) A 81
3) Rotational speed	Response to rotational speed of equipment in which bearings will be installed (The limiting speed for bearing is expressed as allowable speed, and this value is specified in the bearing specification table.)	<ul style="list-style-type: none"> Since the allowable speed differs greatly depending not only upon bearing type but on bearing size, cage, accuracy, load and lubrication, all factors must be considered in selecting bearings. In general, the following bearings are the most widely used for high speed operation. (deep groove ball bearings, angular contact ball bearings, cylindrical roller bearings) 	A 18 (Table 3-2) A 78
4) Running accuracy	Accurate rotation delivering required performance (Dimension accuracy and running accuracy of bearings are provided by JIS, etc.)	<ul style="list-style-type: none"> Performance required differs depending on equipment in which bearings are installed : for instance, machine tool spindles require high running accuracy, gas turbines require high speed rotation, and control equipment requires low friction. In such cases, bearings of tolerance class 5 or higher are required. The following are the most widely used bearings. (deep groove ball bearings, angular contact ball bearings, cylindrical roller bearings) 	A 18 (Table 3-2) A 52
5) Rigidity	Rigidity that delivers the bearing performance required (When load is applied to a bearing, elastic deformation occurs at the point where its rolling elements contact the raceway surface. The higher the rigidity that bearings possess, the better they control elastic deformation.)	<ul style="list-style-type: none"> In machine tool spindles and automobile final drives, bearing rigidity as well as rigidity of equipment itself must be enhanced. Elastic deformation occurs less in roller bearings than in ball bearings. Rigidity can be enhanced by providing preload. This method is suitable for use with angular contact ball bearings and tapered roller bearings. 	A 18 (Table 3-2) A 106

Table 3-1 (2) Selection of bearing type

Items to be considered	Selection method	Reference page No.
<p>6) Misalignment (aligning capability)</p> <p>Operating conditions which cause misalignment (shaft deflection caused by load, inaccuracy of shaft and housing, mounting errors) can affect bearing performance</p> <p>(Allowable misalignment (in angle) for each bearing type is described in the section before the bearing specification table, to facilitate determination of the self-aligning capability of bearings.)</p>	<ul style="list-style-type: none"> Internal load caused by excessive misalignment damages bearings. Bearings designed to absorb such misalignment should be selected. The higher the self-aligning capability that bearings possess, the larger the angular misalignment that can be absorbed. The following is the general order of bearings when comparing allowable angular misalignment : (cylindrical roller bearings < tapered roller bearings < deep groove ball bearings, angular contact ball bearings < spherical roller bearings, self-aligning ball bearings) 	<p>A 18 (Table 3-2)</p>
<p>7) Mounting and dismounting</p> <p>Methods and frequency of mounting and dismounting required for periodic inspection</p>	<ul style="list-style-type: none"> Cylindrical roller bearings, needle roller bearings and tapered roller bearings, with separable inner and outer rings, are recommended for applications in which mounting and dismounting is conducted frequently. Use of sleeve eases the mounting of self-aligning ball bearings and spherical roller bearings with tapered bore. 	<p>A 18 (Table 3-2)</p>

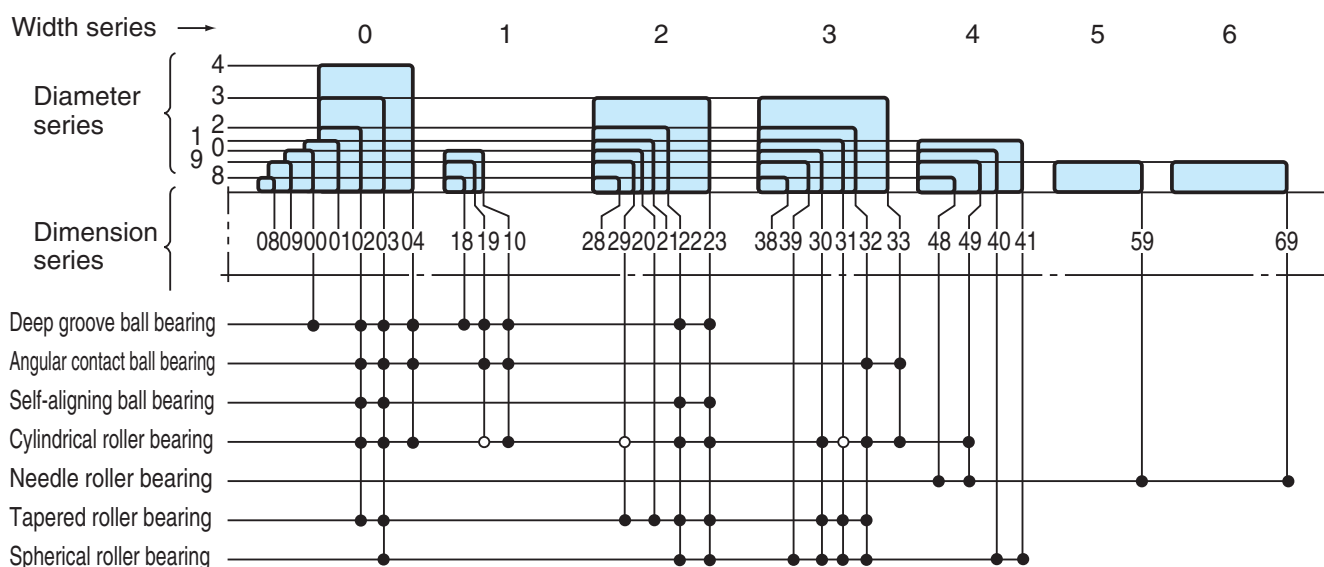





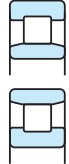
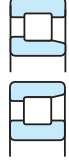
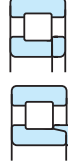
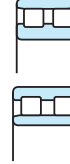

Fig. 3-1 Radial bearing dimension series

Table 3-2 Performance comparison of bearing type

		Deep groove ball bearing 	Angular contact ball bearing			Four-point contact ball bearing 	Self-aligning ball bearing 	Cylindrical roller bearing			
			Single-row 	Matched pair or stack 	Double-row 			NU · N 	NJ · NF 	NUP · NH 	NN · NNU 
Load resistance	Radial load	○	○	◎	◎	○	○	◎	◎	◎	◎
	Axial load	○ ↔	◎ ←	◎ ↔ *	◎ ↔ *	◎ ↔	△ ↔	×	△ ←	△ ↔	×
	Combined load radial and axial	○	○	◎	◎	○	△	×	△	△	×
	Vibration or impact load	△	△	△	△	△	△	◎	◎	◎	◎
High speed adaptability	◎	◎	◎	○	◎	△	◎	◎	◎	◎	◎
High accuracy	◎	◎	◎	○	◎	△	◎	◎	◎	◎	◎
Low noise level/low torque	◎						○				
Rigidity			○		○		○	○	○	◎	
Misalignment	○	△	×	×	×	◎	△	△	△	△	
Inner and outer ring separability	×	×	×	×	■ *	×	■	■	■	■	■
Arrangement	Fixed side	■ ↔	■ ←	■ ↔	■ ↔ *	■ ↔	■ ↔	×	■ ←	■ ↔	×
	Free side	□		□	□	□	□	■	□	□	■
Remarks		A pair of bearings mounted facing each other.	*DT arrangement is effective for one direction only.	*Filling slot type is effective for one direction only.	*Non-separable type is also available.						
Reference page No.	A4 B4	A5 B52			A6 B52	A6 B134	A7 B154				

◎ Excellent ○ Good △ Fair × Unacceptable ↔ Both directions ← One direction only

	Needle roller bearing (machined ring type)	Tapered roller bearing		Spherical roller bearing	Thrust ball bearing		Double direction angular contact thrust ball bearing	Cylindrical roller thrust bearing	Needle roller thrust bearing	Tapered roller thrust bearing	Spherical thrust roller bearing	Reference page No.
		Single-row	Double-row, four-row		With flat back faces	With aligning seat race						
												—
	○	○	○	○	×	×	×	×	×	×	△	—
	×	○ ←	○ ↔	△ ↔	○ ←*	○ ←*	○ ↔	○ ←	○ ←	○ ←	○ ←	—
	×	○	○	△	×	×	×	×	×	×	△	—
	○	○	○	○	△	△	△	○	○	○	○	—
	○	○	○	○	△	△	○	△	△	△	△	A16 A78
		○			○		○					A16, 52 A111
												A16
	○	○	○				○	○	○	○		A16
	△	△	△	○	×	○	×	×	×	×	○	A17 Description before specification table
	■	■	■	×	■	■	■	■	■*	■	■	—
	×	■ ←	■ ↔	■ ↔								A20
	■		□	□								A20
		A pair of bearings mounted facing each other.			*Double direction bearings are effective for both directions.				*Non-separable type is also available.			—
	A8 B374	A9 B200		A10 B302	A11 B348		— C47	A12 —	A12 B374	A13 —	A13 B366	—

■ Acceptable

□ Acceptable, but shaft shrinkage must be compensated for.

4. Selection of bearing arrangement

As bearing operational conditions vary depending on devices in which bearings are mounted, different performances are demanded of bearings. Normally, two or more bearings are used on one shaft.

In many cases, in order to locate shaft positions in the axial direction, one bearing is mounted on the fixed side first, then the other bearing is mounted on the free side.

Table 4-1 Bearings on fixed and free sides

	Features	Recommended bearing type	Example No.
Fixed side bearing	<ul style="list-style-type: none"> • This bearing determines shaft axial position. • This bearing can accommodate both radial and axial loads. • Since axial load in both directions is imposed on this bearing, strength must be considered in selecting the bearing for this side. 	Deep groove ball bearing Matched pair or stack angular contact ball bearing Double-row angular contact ball bearing Self-aligning ball bearing Cylindrical roller bearing with rib (NUP and NH types) Double-row tapered roller bearing Spherical roller bearing	
Free side bearing	<ul style="list-style-type: none"> • This bearing is employed to compensate for expansion or shrinkage caused by operating temperature change and to allow adjustment of bearing position. • Bearings which accommodate radial load only and whose inner and outer rings are separable are recommended as free side bearings. • In general, if non-separable bearings are used on free side, clearance fit is provided between outer ring and housing to compensate for shaft movement through bearings. In some cases, clearance fit between shaft and inner ring is utilized. 	<ul style="list-style-type: none"> • Separable types Cylindrical roller bearing (NU and N types) Needle roller bearing (NA type, etc.) • Non-separable types Deep groove ball bearing Matched pair angular contact ball bearing (Back-to-back arrangement) Double-row angular contact ball bearing Self-aligning ball bearing Double-row tapered roller bearing (TDO type) Spherical roller bearing 	Examples 1–11
When fixed and free sides are not distinguished	<ul style="list-style-type: none"> • When bearing intervals are short and shaft shrinkage does not greatly affect bearing operation, a pair of angular contact ball bearings or tapered roller bearings is used in paired mounting to accommodate axial load. • After mounting, the axial clearance is adjusted using nuts or shims. 	Deep groove ball bearing Angular contact ball bearing Self-aligning ball bearing Cylindrical roller bearing (NJ and NF types) Tapered roller bearing Spherical roller bearing	Examples 12–16
Bearings for vertical shafts	<ul style="list-style-type: none"> • Bearings which can accommodate both radial and axial loads should be used on fixed side. Heavy axial load can be accommodated using thrust bearings together with radial bearings. • Bearings which can accommodate radial load only are used on free side, compensating for shaft movement. 	<ul style="list-style-type: none"> • Fixed side Matched pair angular contact ball bearing (Back-to-back arrangement) Double-row tapered roller bearing (TDO type) Thrust bearing + radial bearing 	Examples 17 and 18

Table 4-2 (1) Example bearing arrangements

Example	Bearing arrangement		Recommended application	Application example
	Fixed side	Free side		
Ex. 1			<ul style="list-style-type: none"> ○ Suitable for high-speed operation; used for various types of applications. ○ Not recommended for applications that have center displacement between bearings or shaft deflection. 	Medium size motors, air blowers
Ex. 2			<ul style="list-style-type: none"> ○ More suitable than Ex. 1 for operation under heavy load or impact load. Suitable also for high-speed operation. ○ Due to separability, suitable for applications requiring interference of both inner and outer rings. ○ Not recommended for applications that have center displacement between bearings or shaft deflection. 	Traction motors for railway rolling stock
Ex. 3			<ul style="list-style-type: none"> ○ Recommended for applications under heavier or greater impact load than those in Ex. 2. ○ This arrangement requires high rigidity from fixed side bearings mounted back to back, with preload provided. ○ Shaft and housing of accurate dimensions should be selected and mounted properly. 	Steel manufacturing table rollers, lathe spindles
Ex. 4			<ul style="list-style-type: none"> ○ This is recommended for operation at high speed or axial load lighter than in Ex. 3. ○ This is recommended for applications requiring interference of both inner and outer rings. ○ Some applications use double-row angular contact ball bearings on fixed side instead of matched pair angular contact ball bearings. 	Motors
Ex. 5			<ul style="list-style-type: none"> ○ This is recommended for operations under relatively small axial load. ○ This is recommended for applications requiring interference of both inner and outer rings. 	Paper manufacturing calender rollers, diesel locomotive axle journals
Ex. 6			<ul style="list-style-type: none"> ○ This is recommended for operations at high speed and heavy radial load, as well as normal axial load. ○ When deep groove ball bearings are used, clearance must be provided between outside diameter and housing, to prevent application of radial load. 	Diesel locomotive transmissions
Ex. 7			<ul style="list-style-type: none"> ○ This arrangement is most widely employed. ○ This arrangement can accommodate partial axial load as well as radial load. 	Pumps, automobile transmissions

Table 4-2 (2) Example bearing arrangements



Example	Bearing arrangement		Recommended application	Application example
	Fixed side	Free side		
Ex. 8			<ul style="list-style-type: none"> This is recommended for operations with relatively heavy axial load in both directions. Some applications use matched pair angular contact ball bearings on fixed side instead of double-row angular contact ball bearings. 	Worm gear speed reducers
Ex. 9			<ul style="list-style-type: none"> This is the optimum arrangement for applications with possible mounting errors or shaft deflection. Bearings in this arrangement can accommodate partial axial load, as well as heavy radial load. 	Steel manufacturing table roller speed reducers, overhead crane wheels
Ex. 10			<ul style="list-style-type: none"> This is optimum arrangement for applications with possible mounting errors or shaft deflection. Ease of mounting and dismounting, ensured by use of adaptor, makes this arrangement suitable for long shafts which are neither stepped nor threaded. This arrangement is not recommended for applications requiring axial load capability. 	General industrial equipment counter shafts
Ex. 11			<ul style="list-style-type: none"> This is the optimum arrangement for applications with possible mounting errors or shaft deflection. This is recommended for operations under impact load or radial load heavier than that in Ex. 10. This arrangement can accommodate partial axial load as well as radial load. 	Steel manufacturing table rollers
Arrangement in which fixed and free sides are not distinguished			Recommended application	Application example
Ex. 12			<ul style="list-style-type: none"> This arrangement is most popular when applied to small equipment operating under light load. When used with light preloading, thickness-adjusted shim or spring is mounted on one side of outer ring. 	Small motors, small speed reducers, small pumps
Ex. 13	 <p>Back-to-back</p>		<ul style="list-style-type: none"> This is suitable for applications in which rigidity is enhanced by preloading. This is frequently employed in applications requiring high speed operation under relatively large axial load. Back-to-back arrangement is suitable for applications in which moment load affects operation. When preloading is required, care should be taken in preload adjustment. 	Machine tool spindles
	 <p>Face-to-face</p>			

Table 4-2 (3) Example bearing arrangements

Example	Arrangement in which fixed and free sides are not distinguished	Recommended application	Application example
Ex. 14	 <p>Back-to-back</p> <p>Face-to-face</p>	<ul style="list-style-type: none"> ○ This is recommended for operation under impact load or axial load heavier than in Ex. 13. ○ This is suitable for applications in which rigidity is enhanced by preloading. ○ Back-to-back arrangement is suitable for applications in which moment load affects operation. ○ When interference is required between inner ring and shaft, face-to-face arrangement simplifies mounting. This arrangement is effective for applications in which mounting error is possible. ○ When preloading is required, care should be taken in preload adjustment. 	Speed reducers, automobile wheels
Ex. 15		<ul style="list-style-type: none"> ○ This is recommended for applications requiring high speed and high accuracy of rotation under light load. ○ This is suitable for applications in which rigidity is enhanced by preloading. ○ Tandem arrangement and face-to-face arrangement are possible, as is back-to-back arrangement. 	Machine tool spindles
Ex. 16		<ul style="list-style-type: none"> ○ This arrangement provides resistance against heavy radial and impact loads. ○ This is applicable when both inner and outer rings require interference. ○ Care should be taken not to reduce axial internal clearance a critical amount during operation. 	Construction equipment final drive
Application to vertical shafts		Recommended application	Application example
Ex. 17	 <p>Fixed side</p> <p>Free side</p>	<ul style="list-style-type: none"> ○ This arrangement, using matched pair angular contact ball bearings on the fixed side and cylindrical roller bearings on the free side, is suitable for high speed operation. 	Vertical motors, vertical pumps
Ex. 18	 <p>Free side</p> <p>Fixed side</p>	<ul style="list-style-type: none"> ○ This is recommended for operation at low speed and heavy load, in which axial load is heavier than radial load. ○ Due to self-aligning capability, this is suitable for applications in which shaft runout or deflection occurs. 	Crane center shafts, vertical pumps

Accordingly, where the dynamic equivalent load is P , and rotational speed is n , equation (5-4) can be used to calculate the basic dynamic load rating C ; the bearing size most suitable for a specified purpose can then be selected, referring to the bearing specification table.

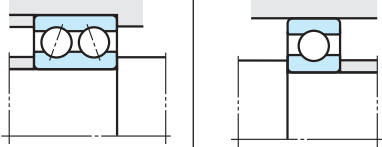
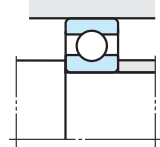
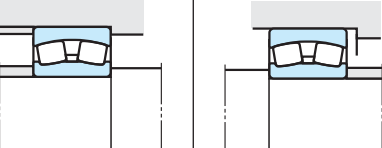
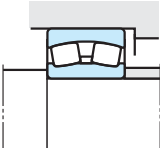
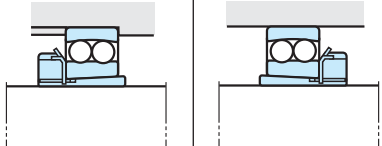
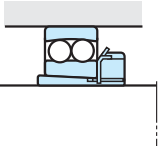
The recommended bearing service life differs depending on the machines with which the bearing is used, as shown in Table 5-4, p. A 28.

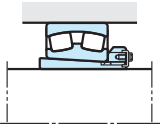
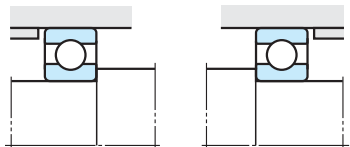
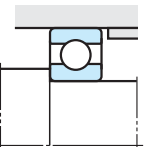
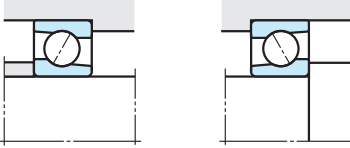
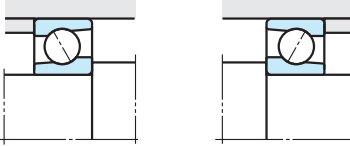
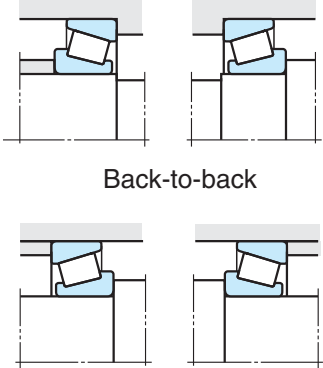
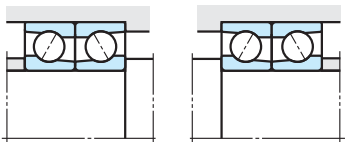
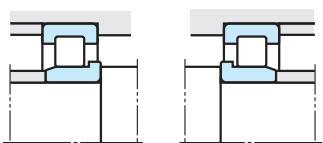
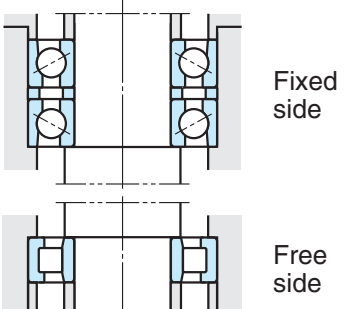
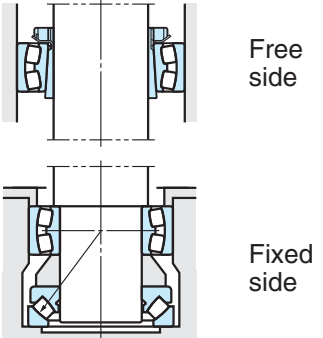
$$C = P \left(L_{10h} \times \frac{60n}{10^6} \right)^{1/p} \dots\dots\dots (5-4)$$

[Reference]

The equations using a service life coefficient (f_h) and rotational speed coefficient (f_n) respectively, based on equation (5-2), are as follows :

$$L_{10h} = 500 f_h^p \dots\dots\dots (5-5)$$

Coefficient of service life :

$$f_h = f_n \frac{C}{P} \dots\dots\dots (5-6)$$

Coefficient of rotational speed :

$$f_n = \left(\frac{10^6}{500 \times 60n} \right)^{1/p} \\ = (0.03n)^{-1/p} \dots\dots\dots (5-7)$$

For reference, the values of f_n , f_h , and L_{10h} can be easily obtained by employing the nomograph attached to this catalog, as an abbreviated method.

[Ball bearing]

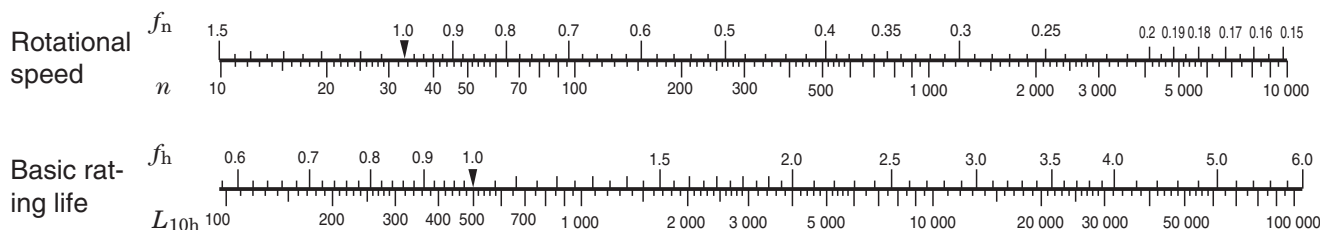

[Roller bearing]

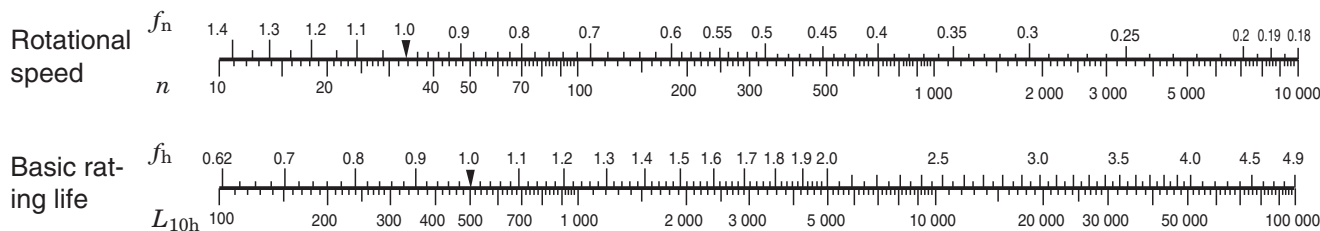

[Reference] Rotational speed (n) and its coefficients (f_n), and service life coefficient (f_h) and basic rating life (L_{10h})

5-2-3 Correction of basic dynamic load rating for high temperature use and dimension stabilizing treatment

In high temperature operation, bearing material hardness deteriorates, as material compositions are altered. As a result, the basic dynamic load rating is diminished. Once altered, material composition is not recovered, even if operating temperatures return to normal.

Therefore, for bearings used in high temperature operation, the basic dynamic load rating should be corrected by multiplying the basic dynamic load rating values specified in the bearing specification table by the temperature coefficient values in Table 5-1.

Table 5-1 Temperature coefficient values

Bearing temperature, °C	125	150	175	200	250
Temperature coefficient	1	1	0.95	0.90	0.75

Since normal heat treatment is not effective in maintaining the original bearing size in extended operation at 120 °C or higher, dimension stabilizing treatment is necessary. Dimension stabilizing treatment codes and their effective temperature ranges are described in Table 5-2.

Since dimension stabilizing treatment diminishes material hardness, the basic dynamic load rating may be reduced for some types of bearings.

Table 5-2 Dimension stabilizing treatment

Dimension stabilizing treatment code	Effective temperature range
S0	Over 100°C, up to 150°C
S1	150°C 200°C
S2	200°C 250°C

5-2-4 Corrected rating life

The basic rating life (L_{10}), expressed using equation (5-1), is (fatigue) life, whose estimate of reliability is 90 %. A certain application requires a service life whose reliability is more than 90 %.

Special materials help extend bearing life, and lubrication and other operating conditions may also affect bearing service life. The corrected rating life can be obtained from the basic rating life using equation (5-8).

$$L_{na} = a_1 a_2 a_3 L_{10} \dots\dots\dots (5-8)$$

where :

L_{na} : corrected rating life 10^6 revolutions
 (estimated reliability (100- n) % : the probability of failure occurrence is expressed by n , taking bearing characteristics and operating conditions into consideration.)

L_{10} : basic rating life 10^6 revolutions
 (estimated reliability 90 %)

a_1 : reliability coefficient
 refer to section (1)

a_2 : bearing characteristic coefficient
 refer to section (2)

a_3 : operating condition coefficient
 refer to section (3)

[Remark]

When bearing dimensions are to be selected given L_{na} greater than 90 % in reliability, the strength of shaft and housing must be considered.

(1) Reliability coefficient a_1

Table 5-3 describes reliability coefficient, a_1 , which is necessary to obtain the corrected rating life of reliability greater than 90 %.

Table 5-3 Reliability coefficient a_1

Reliability, %	L_{na}	a_1
90	L_{10a}	1
95	L_{5a}	0.62
96	L_{4a}	0.53
97	L_{3a}	0.44
98	L_{2a}	0.33
99	L_{1a}	0.21

(2) Bearing characteristic coefficient a_2

The bearing characteristic in relation to bearing life may differ according to bearing materials (steel types and their quality), and may be altered by production process, design, etc. In such cases, the bearing life calculation can be corrected using the bearing characteristic coefficient a_2 .

JTEKT has employed vacuum-degassed bearing steel as JTEKT standard bearing material. It has a significant effect on bearing life extension which was verified through studies at JTEKT laboratory.

The basic dynamic load rating of bearings made of vacuum-degassed bearing steel is specified in the bearing specification table, taking the bearing characteristic coefficient as $a_2 = 1$.

For bearings made of special materials to extend fatigue life, the bearing characteristic coefficient is treated as $a_2 > 1$.

(3) Operating condition coefficient a_3

When bearings are used under operating conditions which directly affect their service life, including improper lubrication, the service life calculation can be corrected by using a_3 .

Under normal lubrication, the calculation can be performed with $a_3 = 1$; and, under favorable lubrication, with $a_3 > 1$.

In the following cases, the operating condition coefficient is treated as $a_3 < 1$:

- Operation using lubricant of low kinematic viscosity
 - (Ball bearing.....13 mm²/s or less)
 - (Roller bearing.....20 mm²/s or less)
- Operation at very slow rotational speed
 - (Product of rolling element pitch diameter)
 - (and rotational speed is 10 000 or less.)
- Contamination of lubricant is expected
- Greater misalignment of inner and outer rings is present

[Note] When bearing hardness is diminished by heat, the basic dynamic load rating calculation must be corrected (ref. Table 5-1).

[Remark]

When $a_2 > 1$ in employing a special material, if lubrication is not proper, $a_2 \times a_3$ is not always > 1 . In such cases, if $a_3 < 1$, bearing characteristic coefficient is normally treated as $a_2 \leq 1$.

5-2-5 Service life of bearing system comprising two or more bearings

Even for systems which comprise two or more bearings, if one bearing is damaged, the entire system malfunctions.

Where all bearings used in an application are regarded as one system, the service life of the bearing system can be calculated using the following equation,

$$\frac{1}{L^e} = \frac{1}{L_1^e} + \frac{1}{L_2^e} + \frac{1}{L_3^e} + \dots \quad (5-9)$$

where :

- L : rating life of system
- L_1, L_2, L_3, \dots : rating life of each bearing
- e : constant
 - ($e = 10/9$ball bearing)
 - ($e = 9/8$roller bearing)
 - (The mean value is for a system using both ball and roller bearings.)

[Example]

When a shaft is supported by two roller bearings whose service lives are 50 000 hours and 30 000 hours respectively, the rating life of the bearing system supporting this shaft is calculated as follows, using equation (5-9) :

$$\frac{1}{L^{9/8}} = \frac{1}{50\,000^{9/8}} + \frac{1}{30\,000^{9/8}}$$

$$L \doteq 20\,000 \text{ h}$$

The equation suggests that the rating life of these bearings as a system becomes shorter than that of the bearing with the shorter life.

This fact is very important in estimating bearing service life for applications using two or more bearings.

As the above explanation shows, since a_2 and a_3 are inter-dependent, some calculations treat them as one coefficient, a_{23} .

5-2-6 Applications and recommended bearing service life

Since longer service life does not always contribute to economical operation, the most suitable service life for each application and operating conditions should be determined.

For reference, Table 5-4 describes recommended service life in accordance with the application, as empirically determined.

Table 5-4 Recommended bearing service life (reference)

Operating condition	Application	Recommended service life (h)
Short or intermittent operation	Household electric appliance, electric tools, agricultural equipment, heavy cargo hoisting equipment	4 000 – 8 000
Not extended duration, but stable operation required	Household air conditioner motors, construction equipment, conveyers, elevators	8 000 – 12 000
Intermittent but extended operation	Rolling mill roll necks, small motors, cranes	8 000 – 12 000
	Motors used in factories, general gears	12 000 – 20 000
	Machine tools, shaker screens, crushers	20 000 – 30 000
	Compressors, pumps, gears for essential use	40 000 – 60 000
Daily operation more than 8 hr. or continuous extended operation	Escalators	12 000 – 20 000
	Centrifugal separators, air conditioners, air blowers, woodworking equipment, passenger coach axle journals	20 000 – 30 000
	Large motors, mine hoists, locomotive axle journals, railway rolling stock traction motors	40 000 – 60 000
	Paper manufacturing equipment	100 000 – 200 000
24 hr. operation (no failure allowed)	Water supply facilities, power stations, mine water discharge facilities	100 000 – 200 000

5-3 Calculation of loads

Loads affecting bearings includes force exerted by the weight of the object the bearings support, transmission force of devices such as gears and belts, loads generated in equipment during operation etc.

Seldom can these kinds of load be determined by simple calculation, because the load is not always constant.

In many cases, the load fluctuates, and it is difficult to determine the frequency and magnitude of the fluctuation.

Therefore, loads are normally obtained by multiplying theoretical values with various coefficients obtained empirically.

5-3-1 Load coefficient

Even if radial and axial loads are obtained through general dynamic calculation, the actual load becomes greater than the calculated value due to vibration and impact during operation.

In many cases, the load is obtained by multiplying theoretical values by the load coefficient.

$$F = f_w \cdot F_c \dots\dots\dots (5-10)$$

where :

- F : measured load N
- F_c : calculated load N
- f_w : load coefficient (ref. Table 5-5)

5-3-2 Load generated through belt or chain transmission

In the case of belt transmission, the theoretical value of the load affecting the pulley shafts can be determined by obtaining the effective transmission force of the belt.

For actual operation, the load is obtained by multiplying this effective transmission force by the load coefficient (f_w) considering vibration and impact generated during operation, and the belt coefficient (f_b) considering belt tension.

In the case of chain transmission, the load is determined using a coefficient equivalent to the belt coefficient.

This equation (5-11) is as follows ;

$$F_b = \frac{2M}{D_p} \cdot f_w \cdot f_b$$

$$= \frac{19.1 \times 10^6 W}{D_p n} \cdot f_w \cdot f_b \dots\dots\dots (5-11)$$

where :

- F_b : estimated load affecting pulley shaft or sprocket shaft N
- M : torque affecting pulley or sprocket mN · m
- W : transmission force kW
- D_p : pitch circle diameter of pulley or sprocket mm
- n : rotational speed min⁻¹
- f_w : load coefficient (ref. Table 5-5)
- f_b : belt coefficient (ref. Table 5-6)

Table 5-5 Values of load coefficient f_w

Operating condition	Application example	f_w
Operation with little vibration or impact	Motors Machine tools Measuring instrument	1.0 – 1.2
Normal operation (slight impact)	Railway rolling stock Automobiles Paper manufacturing equipment Air blowers Compressors Agricultural equipment	1.2 – 2.0
Operation with severe vibration or impact	Rolling mills Crushers Construction equipment Shaker screens	2.0 – 3.0

Table 5-6 Values of belt coefficient f_b

Belt type	f_b
Timing belt (with teeth)	1.3 – 2.0
V-belt	2.0 – 2.5
Flat belt (with tension pulley)	2.5 – 3.0
Flat belt	4.0 – 5.0
Chain	1.2 – 1.5

5-3-3 Load generated under gear transmission

(1) Loads affecting gear and gear coefficient

In the case of gear transmission, loads transmitted by gearing are theoretically classified into three types: tangential load (K_t), radial load (K_r) and axial load (K_a).

Those loads can be calculated dynamically (using equations (a), (b) and (c), described in section (2)).

To determine the actual gear loads, these theoretical loads must be multiplied by coefficients considering vibration and impact during operation (f_w) (ref. Table 5-5) and the gear coefficient (f_g) (ref. Table 5-7) considering the finish treatment of gears.

Table 5-7 Values of gear coefficient f_g

Gear type	f_g
Precision gears (both pitch error and tooth shape error less than 0.02 mm)	1.0 – 1.1
Normal gears (both pitch error and tooth shape error less than 0.1 mm)	1.1 – 1.3

(2) Calculation of load on gears

(a) Tangential load (tangential force) K_t

(Spur gears, helical gears, double-helical gears, straight bevel gears, spiral bevel gears)

$$K_t = \frac{2M}{D_p} = \frac{19.1 \times 10^6 W}{D_p n} \dots\dots\dots (5-12)$$

(a)~(c) where :

- K_t : gear tangential load N
- K_r : gear radial load N
- K_a : gear axial load N
- M : torque affecting gears $mN \cdot m$
- D_p : gear pitch circle diameter mm
- W : transmitting force kW
- n : rotational speed min^{-1}
- α : gear pressure angle deg
- β : gear helix (spiral) angle deg
- δ : bevel gear pitch angle deg

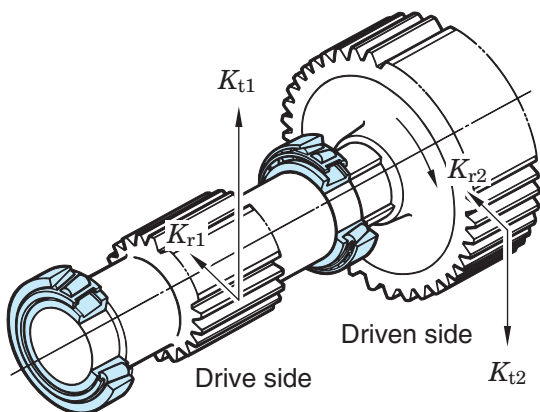

Fig. 5-1 Load on spur gears

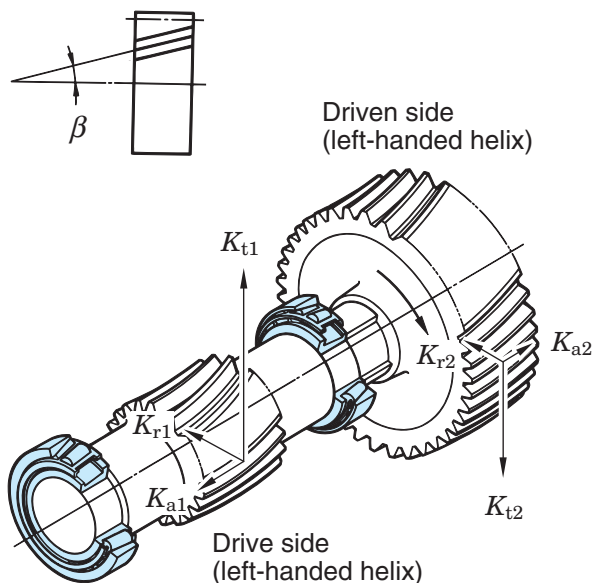

Fig. 5-2 Load on helical gears

		ⓑ Radial load (separating force) K_r	ⓒ Axial load (axial force) K_a
Spur gears		$K_r = K_t \tan \alpha$ (5-13)	0
Helical gears		$K_r = K_t \frac{\tan \alpha}{\cos \beta}$ (5-14)	$K_a = K_t \tan \beta$ (5-20)
Double-helical gears		$K_r = K_t \frac{\tan \alpha}{\cos \beta}$ (5-15)	0
Straight ¹⁾ bevel gears	Drive side	$K_{r1} = K_t \tan \alpha \cos \delta_1$ (5-16)	$K_{a1} = K_t \tan \alpha \sin \delta_1$ (5-21)
	Driven side	$K_{r2} = K_t \tan \alpha \cos \delta_2$ (5-17)	$K_{a2} = K_t \tan \alpha \sin \delta_2$ (5-22)
Spiral ^{1), 2)} bevel gears	Drive side	$K_{r1} = \frac{K_t}{\cos \beta} (\tan \alpha \cos \delta_1 \pm \sin \beta \sin \delta_1)$ (5-18)	$K_{a1} = \frac{K_t}{\cos \beta} (\tan \alpha \sin \delta_1 \mp \sin \beta \cos \delta_1)$ (5-23)
	Driven side	$K_{r2} = \frac{K_t}{\cos \beta} (\tan \alpha \cos \delta_2 \mp \sin \beta \sin \delta_2)$ (5-19)	$K_{a2} = \frac{K_t}{\cos \beta} (\tan \alpha \sin \delta_2 \pm \sin \beta \cos \delta_2)$ (5-24)

[Notes] 1) Codes with subscript 1 and 2 shown in equations are respectively applicable to drive side gears and driven side gears.

2) Symbols (+) and (-) denote the following ;

- { Symbols in upper row : clockwise rotation accompanied by right-handed spiral
or counterclockwise rotation with left-handed spiral }
- { Symbols in lower row : counterclockwise rotation with right-handed spiral or
clockwise rotation with left-handed spiral }

[Remark] Rotating directions are described as viewed at the back of the apex of the pitch angle.

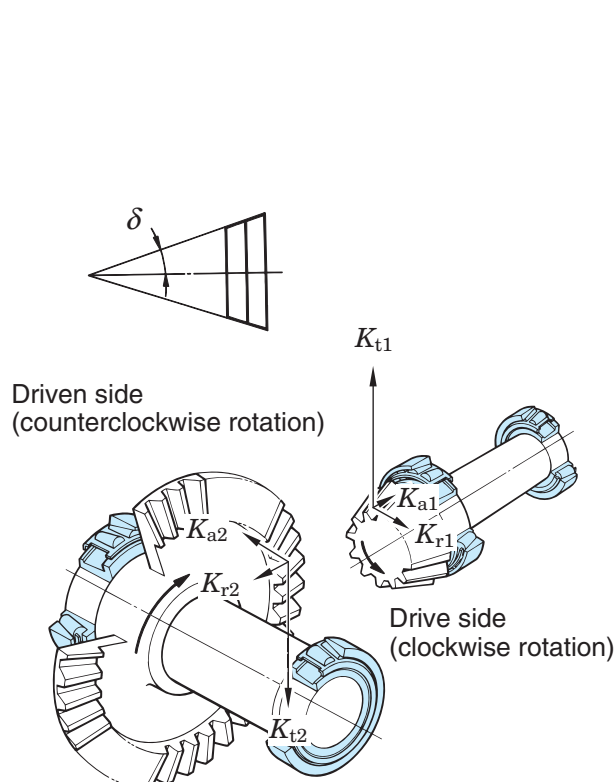

Fig. 5-3 Load on straight bevel gears

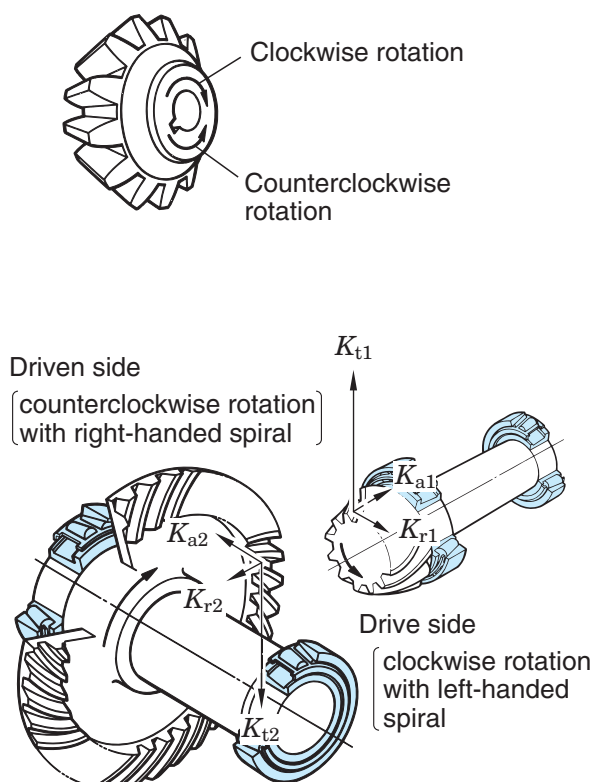

Fig. 5-4 Load on spiral bevel gears

5-3-4 Load distribution on bearings

The load distribution affecting bearings can be calculated as follows: first, radial force components are calculated, then, the sum of vectors of the components is obtained in accordance with the load direction.

Calculation examples of radial load distribution are described in the following section.

[Remark]

Bearings shown in Exs. 3 to 5 are affected by components of axial force when these bearings accommodate radial load, and axial load (K_a) which is transferred externally, i.e. from gears.

For calculation of the axial load in this case, refer to page A 34.

Example 1 Fundamental calculation (1)

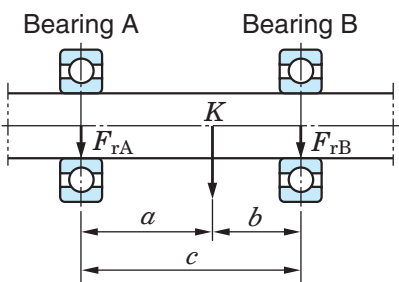

$$F_{rA} = \frac{b}{c} K$$

$$F_{rB} = \frac{a}{c} K \quad \dots (5-25)$$

Example 3 Gear load distribution (1)

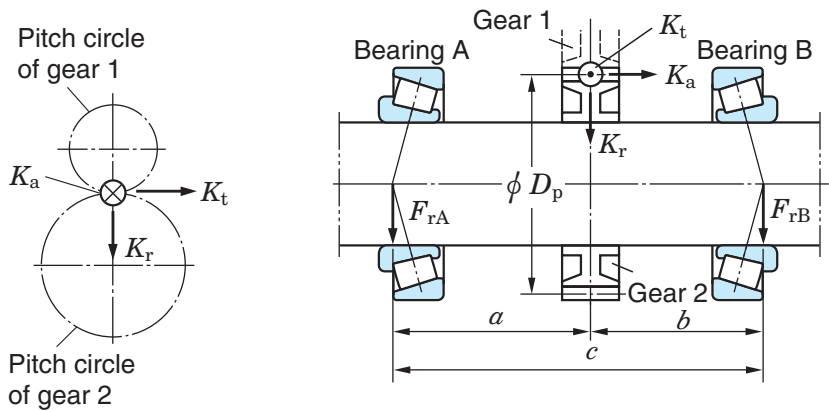

$$F_{rA} = \sqrt{\left(\frac{b}{c} K_t\right)^2 + \left(\frac{b}{c} K_r - \frac{D_p}{2c} K_a\right)^2}$$

$$F_{rB} = \sqrt{\left(\frac{a}{c} K_t\right)^2 + \left(\frac{a}{c} K_r + \frac{D_p}{2c} K_a\right)^2} \quad \dots (5-27)$$

Example 2 Fundamental calculation (2)

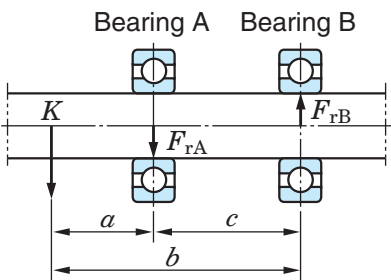

$$F_{rA} = \frac{b}{c} K$$

$$F_{rB} = \frac{a}{c} K \quad \dots (5-26)$$

Example 4 Gear load distribution (2)

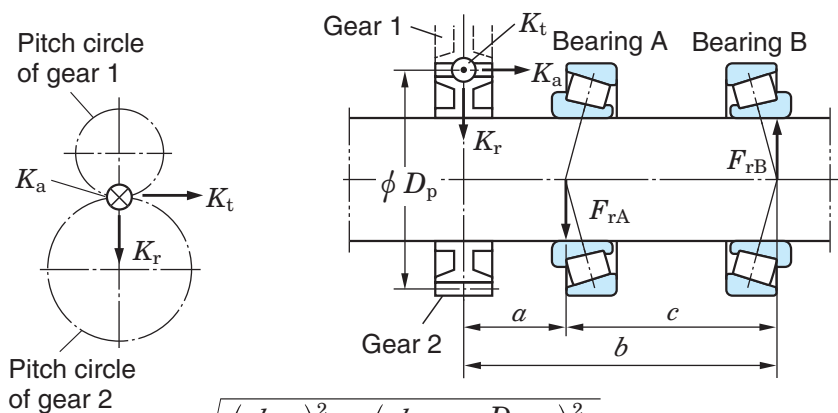

$$F_{rA} = \sqrt{\left(\frac{b}{c} K_t\right)^2 + \left(\frac{b}{c} K_r - \frac{D_p}{2c} K_a\right)^2}$$

$$F_{rB} = \sqrt{\left(\frac{a}{c} K_t\right)^2 + \left(\frac{a}{c} K_r - \frac{D_p}{2c} K_a\right)^2} \quad \dots (5-28)$$

Description of signs in Examples 1 to 5

F_{rA} : radial load on bearing A	N	D_p : gear pitch circle diameter	mm
F_{rB} : radial load on bearing B	N	\odot : denotes load direction (upward	perpendicular to paper surface)
K : shaft load	N	\otimes : denotes load direction (downward	perpendicular to paper surface)
K_t, K_r, K_a : gear load (ref. A 30)	N		

Example 5 Simultaneous application of gear load and other load

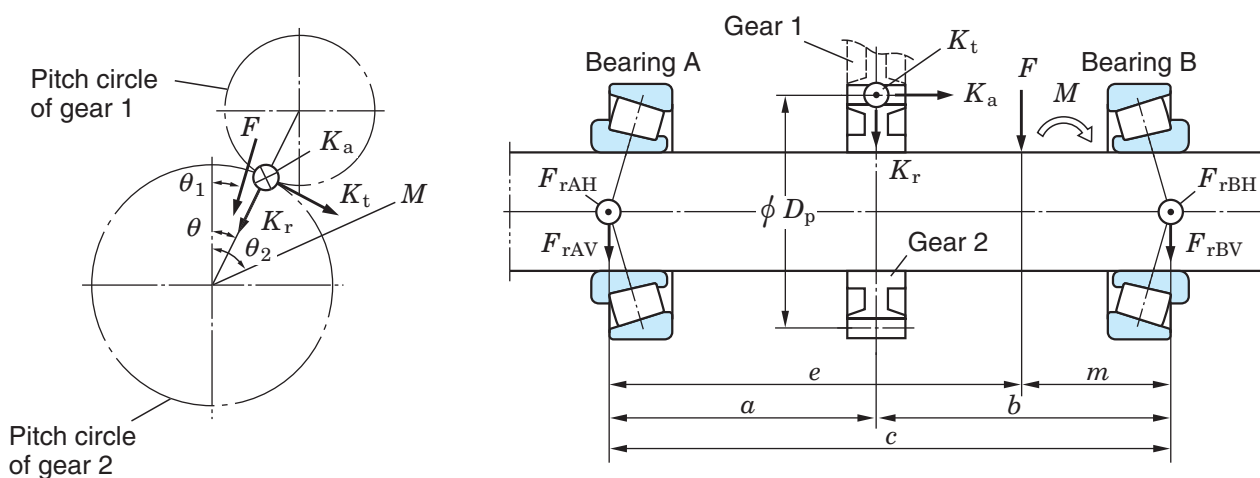

(Gears 1 and 2 are engaged with each other at angle θ . External load F , moment M , are applied to these gears at angles θ_1 and θ_2 .)

- Perpendicular radial component force (upward and downward along diagram)

$$F_{rAV} = \frac{b}{c} (K_r \cos \theta + K_t \sin \theta) - \frac{D_p}{2c} K_a \cos \theta + \frac{m}{c} F \cos \theta_1 - \frac{M}{c} \cos \theta_2$$

$$F_{rBV} = \frac{a}{c} (K_r \cos \theta + K_t \sin \theta) + \frac{D_p}{2c} K_a \cos \theta + \frac{e}{c} F \cos \theta_1 + \frac{M}{c} \cos \theta_2$$

- Horizontal radial component force (upward and downward perpendicular to diagram)

$$F_{rAH} = \frac{b}{c} (K_r \sin \theta - K_t \cos \theta) - \frac{D_p}{2c} K_a \sin \theta + \frac{m}{c} F \sin \theta_1 - \frac{M}{c} \sin \theta_2$$

$$F_{rBH} = \frac{a}{c} (K_r \sin \theta - K_t \cos \theta) + \frac{D_p}{2c} K_a \sin \theta + \frac{e}{c} F \sin \theta_1 + \frac{M}{c} \sin \theta_2$$

- Combined radial force

$$F_{rA} = \sqrt{F_{rAV}^2 + F_{rAH}^2} \dots\dots\dots (5-29) \quad \left(\text{When } \theta, F, \text{ and } M \text{ are zero, the same result as in Ex. 3 is obtained} \right)$$

$$F_{rB} = \sqrt{F_{rBV}^2 + F_{rBH}^2}$$

5-4 Dynamic equivalent load

Bearings are used under various operating conditions; however, in most cases, bearings receive radial and axial load combined, while the load magnitude fluctuates during operation.

Therefore, it is impossible to directly compare the actual load and basic dynamic load rating.

The two are compared by replacing the loads applied to the shaft center with one of a constant magnitude and in a specific direction, that yields the same bearing service life as under actual load and rotational speed.

This theoretical load is referred to as the dynamic equivalent load (P).

5-4-1 Calculation of dynamic equivalent load

Dynamic equivalent loads for radial bearings and thrust bearings ($\alpha \neq 90^\circ$) which receive a combined load of a constant magnitude in a specific direction can be calculated using the following equation,

$$P = XF_r + YF_a \quad \dots\dots\dots (5-30)$$

where :

- P : dynamic equivalent load N
- P_r : dynamic equivalent radial load
- P_a : dynamic equivalent axial load
- F_r : radial load N
- F_a : axial load N
- X : radial load factor
- Y : axial load factor

(values of X and Y are listed in the bearing specification table.)

■ When $F_a/F_r \leq e$ for single-row radial bearings, it is taken that $X = 1$, and $Y = 0$. Hence, the dynamic equivalent load rating is $P_r = F_r$.

(Values of e , which designates the limit of F_a/F_r , are listed in the bearing specification table.)

■ For single-row angular contact ball bearings and tapered roller bearings, axial component forces (F_{ac}) are generated as shown in Fig. 5-5, therefore a pair of bearings is arranged face-to-face or back-to-back.

The axial component force can be calculated using the following equation.

$$F_{ac} = \frac{F_r}{2Y} \quad \dots\dots\dots (5-31)$$

Table 5-8 describes the calculation of the dynamic equivalent load when radial loads and external axial loads (K_a) are applied to bearings.

Paired mounting	
Back-to-back arrangement	Face-to-face arrangement

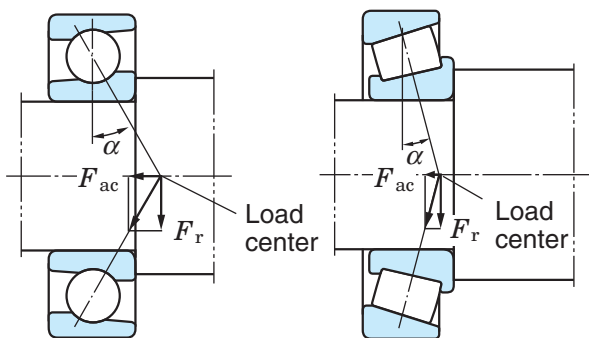

(Load center position is listed in the bearing specification table.)

Fig. 5-5 Axial component force

- For thrust ball bearings with contact angle $\alpha = 90^\circ$, to which an axial load is applied, $P_a = F_a$.
- The dynamic equivalent load of spherical thrust roller bearing can be calculated using the following equation.

$$P_a = F_a + 1.2 F_r \dots\dots\dots (5-32)$$

where : $F_r/F_a \leq 0.55$

Table 5-8 Dynamic equivalent load calculation : when a pair of single-row angular contact ball bearings or tapered roller bearings is arranged face-to-face or back-to-back.

Loading condition	Bearing	Axial load	Dynamic equivalent load
$\frac{F_{rB}}{2Y_B} + K_a \geq \frac{F_{rA}}{2Y_A}$	Bearing A	$\frac{F_{rB}}{2Y_B} + K_a$	$P_A = XF_{rA} + Y_A \left(\frac{F_{rB}}{2Y_B} + K_a \right)$ $P_A = F_{rA}$, where $P_A < F_{rA}$
	Bearing B	—	$P_B = F_{rB}$
$\frac{F_{rB}}{2Y_B} + K_a < \frac{F_{rA}}{2Y_A}$	Bearing A	—	$P_A = F_{rA}$
	Bearing B	$\frac{F_{rA}}{2Y_A} - K_a$	$P_B = XF_{rB} + Y_B \left(\frac{F_{rA}}{2Y_A} - K_a \right)$ $P_B = F_{rB}$, where $P_B < F_{rB}$
$\frac{F_{rB}}{2Y_B} \leq \frac{F_{rA}}{2Y_A} + K_a$	Bearing A	—	$P_A = F_{rA}$
	Bearing B	$\frac{F_{rA}}{2Y_A} + K_a$	$P_B = XF_{rB} + Y_B \left(\frac{F_{rA}}{2Y_A} + K_a \right)$ $P_B = F_{rB}$, where $P_B < F_{rB}$
$\frac{F_{rB}}{2Y_B} > \frac{F_{rA}}{2Y_A} + K_a$	Bearing A	$\frac{F_{rB}}{2Y_B} - K_a$	$P_A = XF_{rA} + Y_A \left(\frac{F_{rB}}{2Y_B} - K_a \right)$ $P_A = F_{rA}$, where $P_A < F_{rA}$
	Bearing B	—	$P_B = F_{rB}$

[Remarks] 1. These equations can be used when internal clearance and preload during operation are zero.
2. Radial load is treated as positive in the calculation, if it is applied in a direction opposite that shown in Fig. in Table 5-8.

5-4-2 Mean dynamic equivalent load

When load magnitude or direction varies, it is necessary to calculate the mean dynamic equivalent load, which provides the same length of bearing service life as that under the actual load fluctuation.

The mean dynamic equivalent load (P_m) under different load fluctuations is described using Graphs (1) to (4).

As shown in Graph (5), the mean dynamic equivalent load under stationary and rotating load applied simultaneously, can be obtained using equation (5-37).

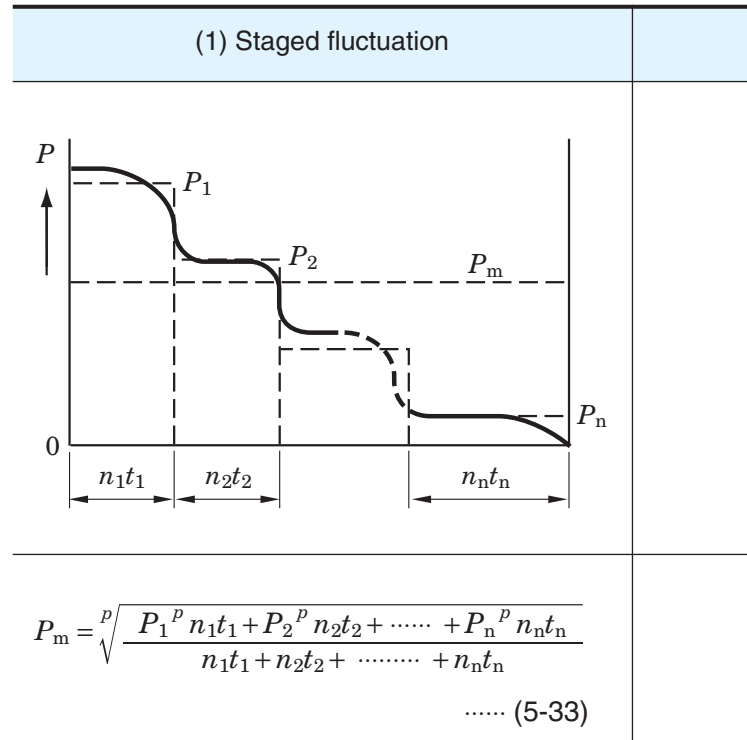

Symbols for Graphs (1) to (4)

P_m : mean dynamic equivalent load	N
P_1 : dynamic equivalent load applied for t_1 hours at rotational speed n_1	N
P_2 : dynamic equivalent load applied for t_2 hours at rotational speed n_2	N
⋮	⋮
P_n : dynamic equivalent load applied for t_n hours at rotational speed n_n	N
P_{min} : minimum dynamic equivalent load	N
P_{max} : maximum dynamic equivalent load	N
$\Sigma n_i t_i$: total rotation in (t_1 to t_i) hours	
p : for ball bearings, $p = 3$	
for roller bearings, $p = 10/3$	

[Reference] Mean rotational speed n_m can be calculated using the following equation :

$$n_m = \frac{n_1 t_1 + n_2 t_2 + \dots + n_n t_n}{t_1 + t_2 + \dots + t_n}$$

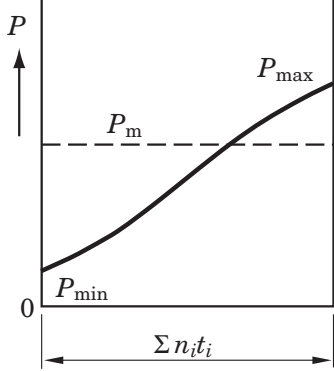
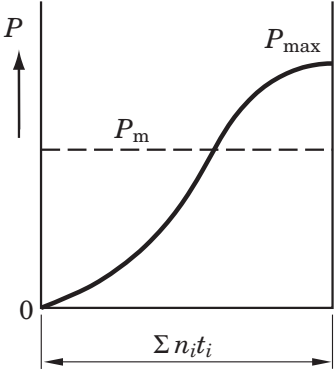
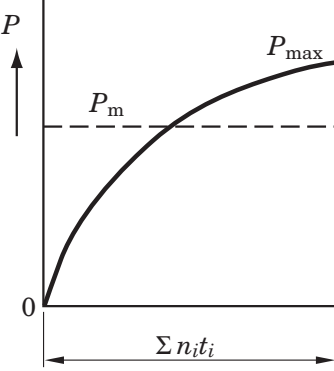
(2) Stageless fluctuation	(3) Fluctuation forming sine curve	(4) Fluctuation forming sine curve (upper half of sine curve)
		
$P_m = \frac{P_{\min} + 2 P_{\max}}{3} \dots\dots (5-34)$	$P_m = 0.68 P_{\max} \dots\dots (5-35)$	$P_m = 0.75 P_{\max} \dots\dots (5-36)$

(5) Stationary load and rotating load acting simultaneously

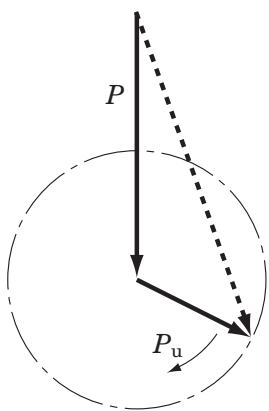

$$P_m = f_m (P + P_u) \dots\dots (5-37)$$

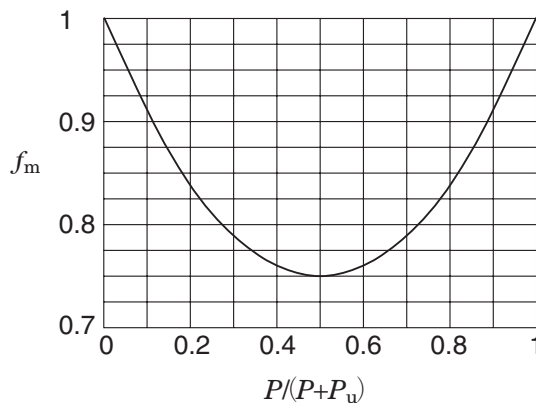

Fig. 5-6 Coefficient f_m

where :

- P_m : mean dynamic equivalent load N
- f_m : coefficient (refer. Fig. 5-6)
- P : stationary load N
- P_u : rotating load N

5-5 Basic static load rating and static equivalent load

5-5-1 Basic static load rating

Excessive static load or impact load even at very low rotation causes partial permanent deformation of the rolling element and raceway contacting surfaces. This permanent deformation increases with the load; if it exceeds a certain limit, smooth rotation will be hindered.

The basic static load rating is the static load which responds to the calculated contact stress shown below, at the contact center between the raceway and rolling elements which receive the maximum load.

- Self-aligning ball bearings ... 4 600 MPa
- Other ball bearings 4 200 MPa
- Roller bearings 4 000 MPa

The total extent of contact stress-caused permanent deformation on surfaces of rolling elements and raceway will be approximately 0.000 1 times greater than the rolling element diameter.

The basic static load rating for radial bearings is specified as the basic static radial load rating, and for thrust bearings, as the basic static axial load rating. These load ratings are listed in the bearing specification table, using C_{0r} and C_{0a} respectively.

These values are prescribed by ISO 78/1987 and are subject to change by conformance to the latest ISO standards.

5-5-2 Static equivalent load

The static equivalent load is a theoretical load calculated such that, during rotation at very low speed or when bearings are stationary, the same contact stress as that imposed under actual loading condition is generated at the contact center between raceway and rolling element to which the maximum load is applied.

For radial bearings, radial load passing through the bearing center is used for the calculation; for thrust bearings, axial load in a direction along the bearing axis is used.

The static equivalent load can be calculated using the following equations.

[Radial bearings]

...The greater value obtained by the following two equations is used.

$$P_{0r} = X_0 F_r + Y_0 F_a \quad \dots\dots\dots (5-38)$$

$$P_{0r} = F_r \quad \dots\dots\dots (5-39)$$

[Thrust bearings]

($\alpha \neq 90^\circ$)

$$P_{0a} = X_0 F_r + F_a \quad \dots\dots\dots (5-40)$$

[When $F_a < X_0 F_r$,
the solution becomes less accurate.]

($\alpha = 90^\circ$)

$$P_{0a} = F_a \quad \dots\dots\dots (5-41)$$

where :

P_{0r} : static equivalent radial load N

P_{0a} : static equivalent axial load N

F_r : radial load N

F_a : axial load N

X_0 : static radial load factor

Y_0 : static axial load factor

(values of X_0 and Y_0 are listed in the bearing specification table.)

5-5-3 Safety coefficient

The allowable static equivalent load for a bearing is determined by the basic static load rating of the bearing; however, bearing service life, which is affected by permanent deformation, differs in accordance with the performance required of the bearing and operating conditions.

Therefore, a safety coefficient is designated, based on empirical data, so as to ensure safety in relation to basic static load rating.

$$f_s = \frac{C_0}{P_0} \dots\dots\dots (5-42)$$

where :

- f_s : safety coefficient (ref. Table 5-9)
- C_0 : basic static load rating N
- P_0 : static equivalent load N

Table 5-9 Values of safety coefficient f_s

Operating condition		f_s (min.)	
		Ball bearing	Roller bearing
With bearing rotation	When high accuracy is required	2	3
	Normal operation	1	1.5
	When impact load is applied	1.5	3
Without bearing rotation (occasional oscillation)	Normal operation	0.5	1
	When impact load or uneven distribution load is applied	1	2

[Remark] For spherical thrust roller bearings, $f_s \geq 4$.

5-6 Allowable axial load for cylindrical roller bearings

Bearings whose inner and outer rings comprise either a rib or loose rib can accommodate a certain magnitude of axial load, as well as radial load. In such cases, axial load capacity is controlled by the condition of rollers, load capacity of rib or loose rib, lubrication, rotational speed etc.

For certain special uses, a design is available to accommodate very heavy axial loads. In general, axial loads allowable for cylindrical roller bearings can be calculated using the following equation, which are based on empirical data.

$$F_{ap} = 9.8 f_a \cdot f_b \cdot f_p \cdot d_m^2 \dots\dots\dots (5-43)$$

where :

- F_{ap} : maximum allowable axial load N
- f_a : coefficient determined from loading condition (Table 5-10)
- f_b : coefficient determined from bearing diameter series (Table 5-11)
- f_p : coefficient for rib surface pressure (Fig. 5-7)
- d_m : mean value of bore diameter d and outside diameter D mm

$$\left(\frac{d + D}{2} \right)$$

Table 5-10 Values of coefficient determined from loading condition f_a

Loading condition	f_a
Continuous loading	1
Intermittent loading	2
Instantaneous loading	3

Table 5-11 Values of coefficient determined from bearing diameter series f_b

Diameter series	f_b
9	0.6
0	0.7
2	0.8
3	1.0
4	1.2

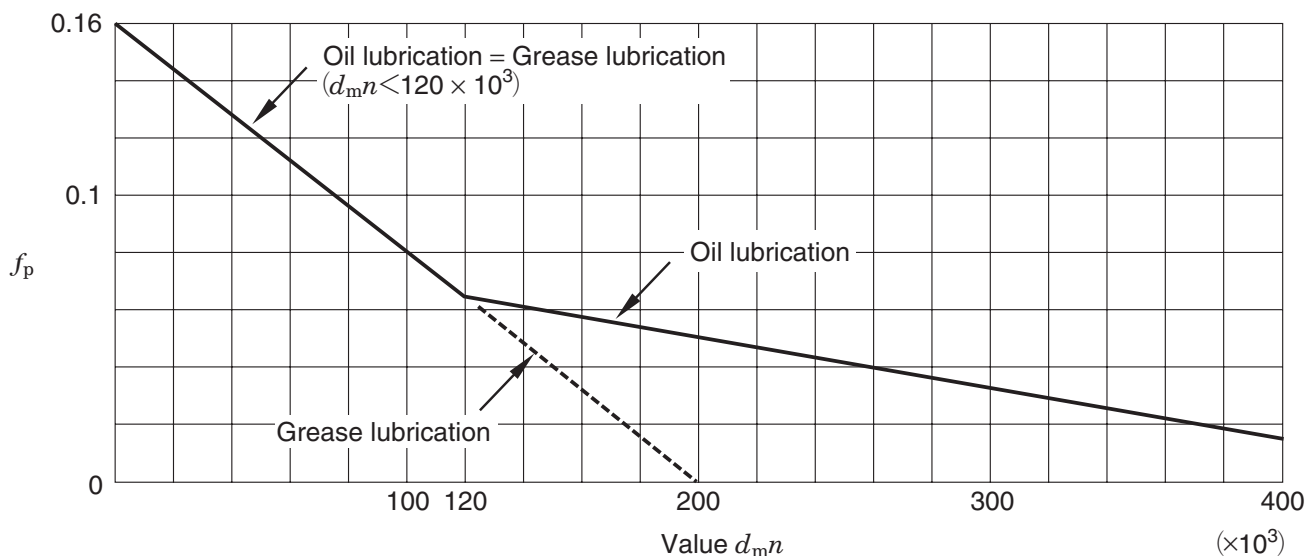
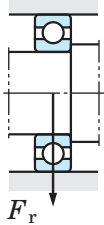
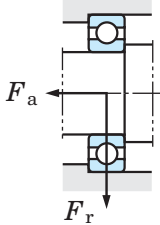

Fig. 5-7 Relationship between coefficient for rib surface pressure f_p and value $d_m n$ (n : rotational speed, min^{-1})

5-7 Applied calculation examples

[Example 1] Bearing service life (time) with 90 % reliability	[Example 2] Bearing service life (time) with 96 % reliability
<p>(Conditions)</p> <p>Deep groove ball bearing : 6308</p> <p>Radial load $F_r = 3\,500\text{ N}$</p> <p>Axial load not applied ($F_a = 0$)</p> <p>Rotational speed $n = 800\text{ min}^{-1}$</p> 	<p>(Conditions)</p> <p>Deep groove ball bearing : 6308</p> <p>Radial load $F_r = 3\,500\text{ N}$</p> <p>Axial load $F_a = 1\,000\text{ N}$</p> <p>Rotational speed $n = 800\text{ min}^{-1}$</p> 
<p>① Basic dynamic load rating (C_r) is obtained from the bearing specification table.</p> $C_r = 40.7\text{ kN}$ <p>② Dynamic equivalent radial load (P_r) is calculated using equation (5-30).</p> $P_r = F_r = 3\,500\text{ N}$ <p>③ Bearing service life (L_{10h}) is calculated using equation (5-2).</p> $L_{10h} = \frac{10^6}{60n} \left(\frac{C}{P} \right)^p$ $= \frac{10^6}{60 \times 800} \times \left(\frac{40.7 \times 10^3}{3\,500} \right)^3 \doteq \underline{\underline{32\,800\text{ h}}}$	<p>① From the bearing specification table ;</p> <ul style="list-style-type: none"> Basic load rating (C_r, C_{0r}), f_0 factor is obtained. $C_r = 40.7\text{ kN}$ $C_{0r} = 24.0\text{ kN}$ $f_0 = 13.2$ <ul style="list-style-type: none"> Values X and Y are obtained by comparing value e, calculated from value $f_0 F_a / C_{0r}$ via proportional interpolation, with value $f_0 F_a / F_r$. $\frac{f_0 F_a}{C_{0r}} = \frac{13.2 \times 1\,000}{24.0 \times 10^3} = 0.550$ $e = 0.22 + (0.26 - 0.22) \times \frac{(0.550 - 0.345)}{(0.689 - 0.345)}$ $= 0.24$ $\frac{F_a}{F_r} = \frac{1\,000}{3\,500} = 0.29 > e$ <p>The result is,</p> $X = 0.56$ $Y = 1.99 - (1.99 - 1.71) \times \frac{(0.550 - 0.345)}{(0.689 - 0.345)}$ $= 1.82$ <p>② Dynamic equivalent load (P_r) is obtained using equation (5-30).</p> $P_r = XF_r + YF_a$ $= (0.56 \times 3\,500) + (1.82 \times 1\,000) = 3\,780\text{ N}$ <p>③ Service life with 90 % reliability (L_{10h}) is obtained using equation (5-2).</p> $L_{10h} = \frac{10^6}{60n} \left(\frac{C}{P} \right)^p$ $= \frac{10^6}{60 \times 800} \times \left(\frac{40.7 \times 10^3}{3\,780} \right)^3 \doteq \underline{\underline{26\,000\text{ h}}}$ <p>④ Service life with 96 % reliability (L_{4ah}) is obtained using equation (5-8).</p> <p>According to Table 5-3, $a_1 = 0.53, a_2 = 1, a_3 = 1$.</p> $L_{4ah} = a_1 a_2 a_3 L_{10h} = 0.53 \times 1 \times 1 \times 26\,000$ $\doteq \underline{\underline{13\,800\text{ h}}}$

[Example 3] Bearing service life (total revolution)

(Conditions)

Tapered roller bearing

Bearing A : 30207 JR

Bearing B : 30209 JR

Radial load $F_{rA} = 5\,200\text{ N}$

$F_{rB} = 6\,800\text{ N}$

Axial load $K_a = 1\,600\text{ N}$

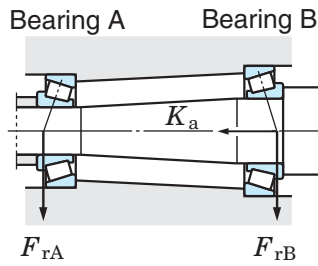

[Example 4] Bearing size selection

(Conditions)

Deep groove ball bearing :

62 series

Required service life :

more than 10 000 h

Radial load $F_r = 2\,000\text{ N}$

Axial load $F_a = 300\text{ N}$

Rotational speed $n = 1\,600\text{ min}^{-1}$

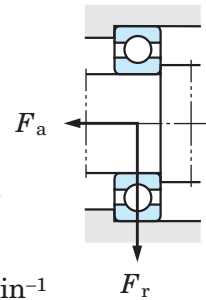

- ① From the bearing specification table, the following specifications are obtained.

	Basic dynamic load rating (C_r)	e	$X^{1)}$	$Y^{1)}$
Bearing A	55.1 kN	0.37	0.4	1.60
Bearing B	67.2 kN	0.40	0.4	1.48

[Note] 1) Those values are used, where $F_a/F_r > e$.

Where $F_a/F_r \leq e$, $X = 1$, $Y = 0$.

- ② Axial load applied to shafts must be calculated, considering the fact that component force in the axial direction is generated when radial load is applied to tapered roller bearings. (ref. equation 5-31, Table 5-8)

$$\frac{F_{rA}}{2 Y_A} + K_a = \frac{5\,200}{2 \times 1.60} + 1\,600 = 3\,225\text{ N}$$

$$\frac{F_{rB}}{2 Y_B} = \frac{6\,800}{2 \times 1.48} = 2\,297\text{ N}$$

Consequently, axial load $\frac{F_{rA}}{2 Y_A} + K_a$ is applied to bearing B.

- ③ Dynamic equivalent load (P_r) is obtained from Table 5-8.

$$P_{rA} = F_{rA} = 5\,200\text{ N}$$

$$P_{rB} = X F_{rB} + Y_B \left(\frac{F_{rA}}{2 Y_A} + K_a \right)$$

$$= 0.4 \times 6\,800 + 1.48 \times 3\,225 = 7\,493\text{ N}$$

- ④ Each bearing service life (L_{10}) is calculated using equation (5-1).

$$L_{10A} = \left(\frac{C_{rA}}{P_{rA}} \right)^{10/3} = \left(\frac{55.1 \times 10^3}{5\,200} \right)^{10/3}$$

$$\doteq 2\,610 \times 10^6 \text{ revolutions}$$

$$L_{10B} = \left(\frac{C_{rB}}{P_{rB}} \right)^{10/3} = \left(\frac{67.2 \times 10^3}{7\,493} \right)^{10/3}$$

$$\doteq 1\,500 \times 10^6 \text{ revolutions}$$

- ① The dynamic equivalent load (P_r) is hypothetically calculated.

The resultant value, $F_a/F_r = 300/2\,000 = 0.15$, is smaller than any other values of e in the bearing specification table.

Hence, JTEKT can consider that $P_r = F_r = 2\,000\text{ N}$.

- ② The required basic dynamic load rating (C_r) is calculated according to equation (5-4).

$$C_r = P_r \left(L_{10h} \times \frac{60n}{10^6} \right)^{1/p}$$

$$= 2\,000 \times \left(10\,000 \times \frac{60 \times 1\,600}{10^6} \right)^{1/3}$$

$$= 19\,730\text{ N}$$

- ③ Among those covered by the bearing specification table, the bearing of the 62 series with C_r exceeding 19 730 N is 6206 R, with bore diameter for 30 mm.

- ④ The dynamic equivalent load obtained at step ① is confirmed by obtaining value e for 6206 R.

Where C_{0r} of 6206 R is 12.8 kN, and f_0 is 13.0

$$f_0 F_a / C_{0r} = 13.0 \times 300 / 12\,800 = 0.305$$

Then, value e can be calculated using proportional interpolation.

$$e = 0.19 + (0.22 - 0.19) \times \frac{(0.305 - 0.172)}{(0.345 - 0.172)}$$

$$= 0.21$$

As a result, it can be confirmed that

$$F_a / F_r = 0.15 < e.$$

Hence, $P_r = F_r$.

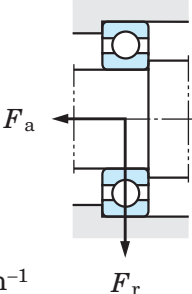
<p>[Example 5] Bearing size selection</p>	<p>[Example 6] Calculation of allowable axial load for cylindrical roller bearings</p>
<p>(Conditions) Deep groove ball bearing : 63 series Required service life : more than 10 000 h Radial load $F_r = 4\,000\text{ N}$ Axial load $F_a = 2\,400\text{ N}$ Rotational speed $n = 1\,000\text{ min}^{-1}$</p> 	<p>(Conditions) Single-row cylindrical roller bearing : NUP 310 Rotational speed $n = 1\,500\text{ min}^{-1}$ Oil lubrication Axial load is intermittently applied.</p>
<p>① The hypothetical dynamic equivalent load (P_r) is calculated : Since $F_a/F_r = 2\,400/4\,000 = 0.6$ is much larger than the value e specified in the bearing specification table, it suggests that the axial load affects the dynamic equivalent load. Hence, assuming that $X = 0.56$, $Y = 1.6$ (approximate mean value of Y), using equation (5-30), $P_r = XF_r + YF_a = 0.56 \times 4\,000 + 1.6 \times 2\,400 = 6\,080\text{ N}$</p> <p>② Using equation (5-4), the required basic dynamic load rating (C_r) is : $C_r = P_r \left(L_{10h} \times \frac{60n}{10^6} \right)^{1/p}$ $= 6\,080 \times \left(10\,000 \times \frac{60 \times 1\,000}{10^6} \right)^{1/3}$ $= 51\,280\text{ N}$</p> <p>③ From the bearing specification table, a 6310 with a bore diameter of 50 mm is selected as a 63 series bearing with C_r exceeding 51 280 N.</p> <p>④ The dynamic equivalent load and basic rating life are confirmed, by calculating the value e for a 6310. Values obtained using the proportional interpolation are : where $f_0 F_a / C_{0r} = 13.2 \times 2\,400 / 38\,300 = 0.827$ $e = 0.268$, $Y = 1.65$. Thus, $F_a / F_r = 0.6 > e$. Using the resultant values, the dynamic equivalent load and basic rating life can be calculated as follows : $P_r = XF_r + YF_a$ $= 0.56 \times 4\,000 + 1.65 \times 2\,400 = 6\,200\text{ N}$ $L_{10h} = \frac{10^6}{60n} \left(\frac{C_r}{P_r} \right)^p$ $= \frac{10^6}{60 \times 1\,000} \times \left(\frac{62.0 \times 10^3}{6\,200} \right)^3 \doteq 16\,700\text{ h}$</p> <p>⑤ The basic rating life of the 6309, using the same steps, is : $L_{10h} \doteq 9\,320\text{ h}$, which does not satisfy the service life requirement.</p>	<p>① Using the bearing specification table, the value d_m for the NUP 310 can be calculated as follows : $d_m = \frac{d + D}{2} = \frac{50 + 110}{2} = 80\text{ mm}$</p> <p>② Each coefficient used in equation (5-43). From values listed in Table 5-10, coefficient f_a related to intermittent load is : $f_a = 2$ From values listed in Table 5-11, coefficient f_b related to diameter series 3 is : $f_b = 1.0$ According to Fig. 5-7, coefficient f_p for allowable rib surface pressure, related to $d_m n = 80 \times 1\,500 = 12 \times 10^4$, is : $f_p = 0.062$</p> <p>③ Using equation (5-43), the allowable axial load F_{ap} is : $F_{ap} = 9.8 f_a \cdot f_b \cdot f_p \cdot d_m^2$ $= 9.8 \times 2 \times 1.0 \times 0.062 \times 80^2$ $\doteq \underline{7\,780\text{ N}}$</p>

[Example 7] Calculation of service life of spur gear shaft bearings

(Conditions)

Tapered roller bearing

Bearing A : 32309 JR

Bearing B : 32310 JR

Gear type : spur gear (normally machined)

Gear pressure angle $\alpha_1 = \alpha_2 = 20^\circ$

Gear pitch circle diameter $D_{p1} = 360$ mm

$D_{p2} = 180$ mm

Transmission power $W = 150$ kW

Rotational speed $n = 1\,000$ min⁻¹

Operating condition: accompanied by impact

Installation locations

$a_1 = 95$ mm, $a_2 = 265$ mm,

$b_1 = 245$ mm, $b_2 = 115$ mm,

$c = 360$ mm

- ① Using equations (5-12) and (5-13), theoretical loads applied to gears (tangential load, K_t ; radial load, K_r) are calculated.

[Gear 1]

$$K_{t1} = \frac{19.1 \times 10^6 W}{D_{p1} n} = \frac{19.1 \times 10^6 \times 150}{360 \times 1\,000}$$

$$= 7\,958 \text{ N}$$

$$K_{r1} = K_{t1} \tan \alpha_1 = 2\,896 \text{ N}$$

[Gear 2]

$$K_{t2} = \frac{19.1 \times 10^6 \times 150}{180 \times 1\,000} = 15\,917 \text{ N}$$

$$K_{r2} = K_{t2} \tan \alpha_2 = 5\,793 \text{ N}$$

- ② The radial load applied to the bearing is calculated, where the load coefficient is determined as $f_w = 1.5$ from Table 5-5, and the gear coefficient as $f_g = 1.2$ from Table 5-7.

[Bearing A]

- Load consisting of K_{t1} and K_{t2} is :

$$K_{tA} = f_w f_g \left(\frac{a_2}{c} K_{t1} + \frac{b_2}{c} K_{t2} \right)$$

$$= 1.5 \times 1.2 \times \left(\frac{265}{360} \times 7\,958 + \frac{115}{360} \times 15\,917 \right) = 19\,697 \text{ N}$$

- Load consisting of K_{r1} and K_{r2} is :

$$K_{rA} = f_w f_g \left(\frac{a_2}{c} K_{r1} - \frac{b_2}{c} K_{r2} \right)$$

$$= 1.5 \times 1.2 \times \left(\frac{265}{360} \times 2\,896 - \frac{115}{360} \times 5\,793 \right) = 506 \text{ N}$$

- Combining the loads of K_{tA} and K_{rA} , the radial load (F_{rA}) applied to bearing A can be calculated as follows :

$$F_{rA} = \sqrt{K_{tA}^2 + K_{rA}^2}$$

$$= \sqrt{19\,697^2 + 506^2} = 19\,703 \text{ N}$$

[Bearing B]

- Load consisting of K_{t1} and K_{t2} is :

$$K_{tB} = f_w f_g \left(\frac{a_1}{c} K_{t1} + \frac{b_1}{c} K_{t2} \right)$$

$$= 1.5 \times 1.2 \times \left(\frac{95}{360} \times 7\,958 + \frac{245}{360} \times 15\,917 \right) = 23\,278 \text{ N}$$

- Load consisting of K_{r1} and K_{r2} is :

$$K_{rB} = f_w f_g \left(\frac{a_1}{c} K_{r1} - \frac{b_1}{c} K_{r2} \right)$$

$$= 1.5 \times 1.2 \times \left(\frac{95}{360} \times 2\,896 - \frac{245}{360} \times 5\,793 \right) = -5\,721 \text{ N}$$

- The radial load (F_{rB}) applied to bearing B can be calculated using the same steps as with bearing A.

$$F_{rB} = \sqrt{K_{tB}^2 + K_{rB}^2}$$

$$= \sqrt{23\,278^2 + (-5\,721)^2} = 23\,971 \text{ N}$$

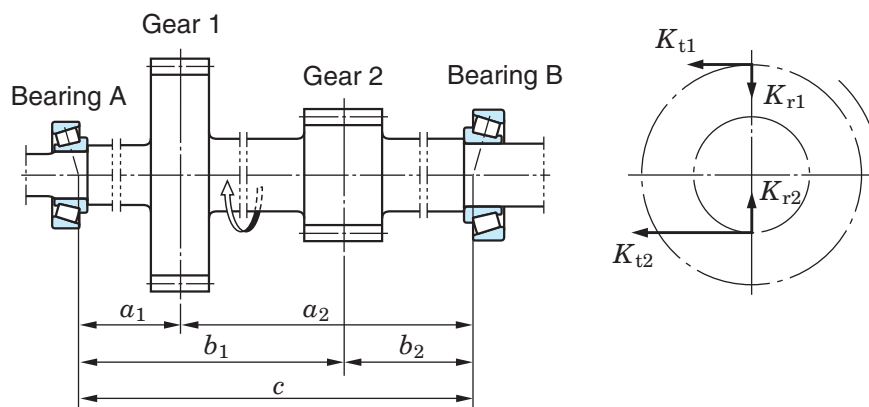

- ③ The following specifications can be obtained from the bearing specification table.

	Basic dynamic load rating (C_r)	e	$X^{1)}$	$Y^{1)}$
Bearing A	146 kN	0.35	0.4	1.74
Bearing B	176 kN			

[Note] 1) Those values are used, where $F_a/F_r > e$.
Where $F_a/F_r \leq e$, $X = 1$, $Y = 0$.

- ④ When an axial load is not applied externally, if the radial load is applied to the tapered roller bearing, an axial component force is generated.

Considering this fact, the axial load applied from the shaft and peripheral parts is to be calculated :

(Equation 5-31, Table 5-8)

$$\frac{F_{rB}}{2 Y_B} = \frac{23\,971}{2 \times 1.74} > \frac{F_{rA}}{2 Y_A} = \frac{19\,703}{2 \times 1.74}$$

According to the result, it is clear that the axial component force ($F_{rB}/2Y_B$) applied to bearing B is also applied to bearing A as an axial load applied from the shaft and peripheral parts.

- ⑤ Using the values listed in Table 5-8, the dynamic equivalent load is calculated, where $K_a = 0$:

$$\begin{aligned} P_{rA} &= X F_{rA} + Y_A \frac{F_{rB}}{2 Y_B} \\ &= 0.4 \times 19\,703 + 1.74 \times \frac{23\,971}{2 \times 1.74} \\ &= 19\,867 \text{ N} \\ P_{rB} &= F_{rB} = 23\,971 \text{ N} \end{aligned}$$

- ⑥ Using equation (5-2), the basic rating life of each bearing is calculated :

[Bearing A]

$$\begin{aligned} L_{10hA} &= \frac{10^6}{60n} \left(\frac{C_{rA}}{P_A} \right)^p \\ &= \frac{10^6}{60 \times 1\,000} \times \left(\frac{146 \times 10^3}{19\,867} \right)^{10/3} \\ &\doteq \underline{12\,900 \text{ h}} \end{aligned}$$

[Bearing B]

$$\begin{aligned} L_{10hB} &= \frac{10^6}{60n} \left(\frac{C_{rB}}{P_B} \right)^p \\ &= \frac{10^6}{60 \times 1\,000} \times \left(\frac{176 \times 10^3}{23\,971} \right)^{10/3} \\ &\doteq \underline{12\,800 \text{ h}} \end{aligned}$$

Reference

Using equation (5-9), the system service life (L_{10hS}) using a pair of bearings is :

$$\begin{aligned} L_{10hS} &= \frac{1}{\left(\frac{1}{L_{10hA}^e} + \frac{1}{L_{10hB}^e} \right)^{1/e}} \\ &= \frac{1}{\left(\frac{1}{12\,900^{9/8}} + \frac{1}{12\,800^{9/8}} \right)^{8/9}} \\ &\doteq \underline{6\,940 \text{ h}} \end{aligned}$$

6. Boundary dimensions and bearing numbers

6-1 Boundary dimensions

Bearing boundary dimensions are dimensions required for bearing installation with shaft or housing, and as described in Fig. 6-1, include the bore diameter, outside diameter, width, height, and chamfer dimension.

These dimensions are standardized by the International Organization for Standardization (ISO 15). JIS B 1512 "rolling bearing boundary dimensions" is based on ISO.

These boundary dimensions are provided, classified into radial bearings (tapered roller bearings are provided in other tables) and thrust bearings.

Boundary dimensions of each bearing are listed in Appendixes at the back of this catalog. In these boundary dimension tables, the outside diameter, width, height, and chamfer dimen-

sions related to bearing bore diameter numbers and bore diameters are listed in diameter series and dimension series.

Reference

- 1) Diameter series is a series of nominal bearing outside diameters provided for respective ranges of bearing bore diameter; and, a dimension series includes width and height as well as diameters.
- 2) Tapered roller bearing boundary dimensions listed in the Appendixes are adapted to conventional dimension series (widths and diameters). Tapered roller bearing boundary dimensions provided in JIS B 1512-2000 are new dimension series based on ISO 355 (ref. descriptions before the bearing specification table); for reference, the bearing specification table covers numeric codes used in these dimension series.

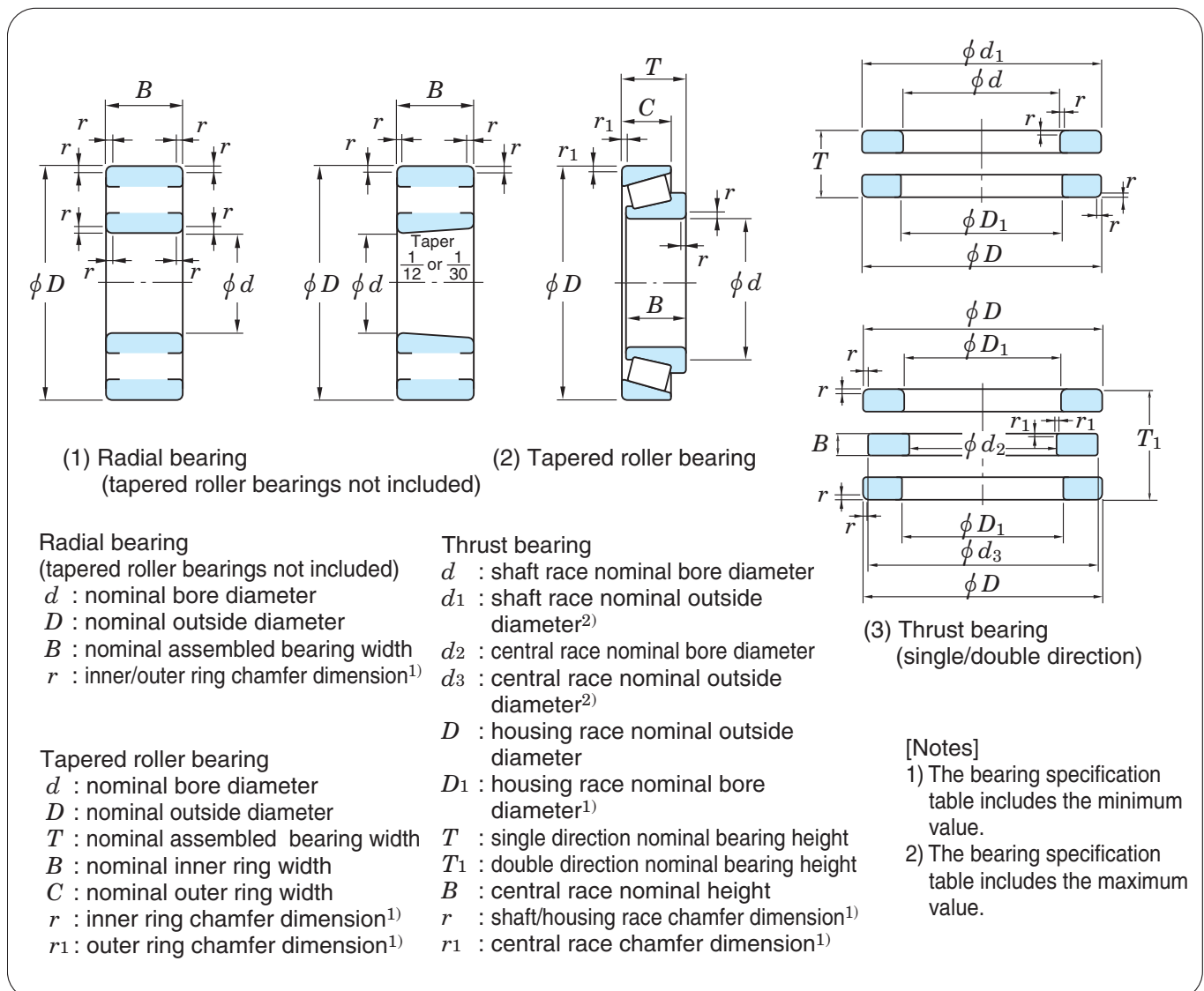

Fig. 6-1 Bearing boundary dimensions

Cross-section dimensions of radial bearings and thrust bearings expressed in dimension series can be compared using Figs. 6-2 and 6-3.

In this way, many dimension series are provided; however, not all dimensions are practically adapted.

Some of them were merely prescribed, given expected future use.

6-2 Dimensions of snap ring grooves and locating snap rings

JIS B 1509 "rolling bearing -radial bearing with locating snap ring-dimensions and tolerances" conforms to the dimensions of snap ring groove for fitting locating snap ring on the outside surface of bearing and the dimensions and tolerances of locating snap ring.

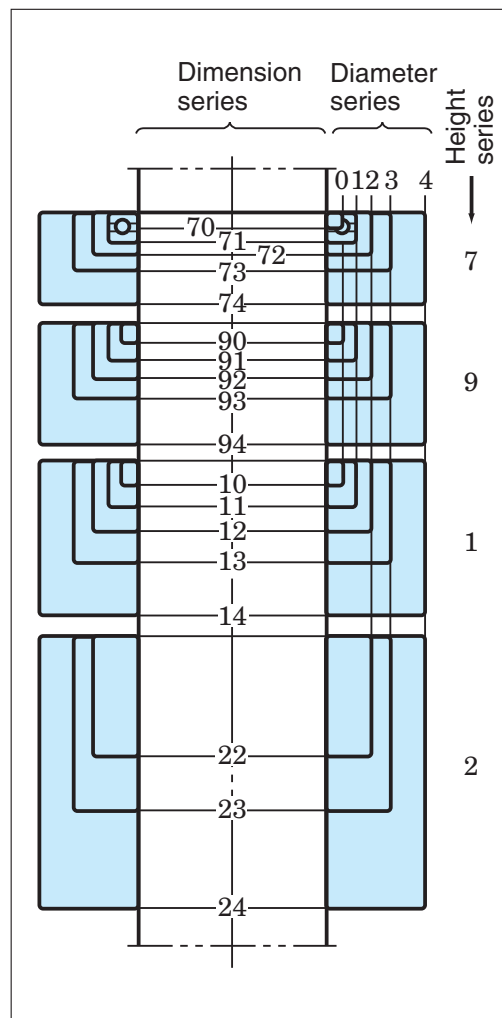

Fig. 6-3 Thrust bearing dimension series diagram (diameter series 5 omitted)

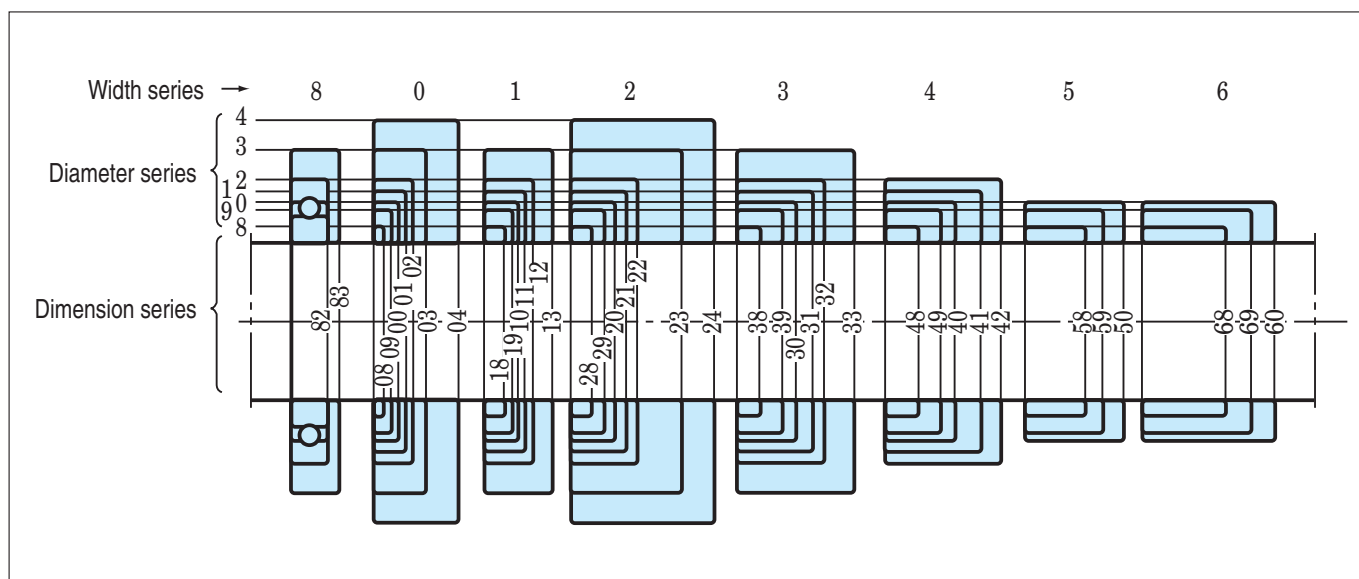

Fig. 6-2 Radial bearing dimension series diagram (diameter series 7 omitted)

6-3 Bearing number

A bearing number is composed of a basic number and a supplementary code, denoting bearing specifications including bearing type, boundary dimensions, running accuracy, and internal clearance.

Bearing numbers of standard bearings corresponding to JIS B 1512 "rolling bearing boundary dimensions" are prescribed in JIS B 1513.

As well as these bearing numbers, JTEKT uses supplementary codes other than those provided by JIS.

Among basic numbers, bearing series codes are listed in Table 6-1, and the composition of bearing numbers is described in Table 6-2, showing the order of arrangement of the parts.

[Examples of bearing numbers]

(Ex. 1)

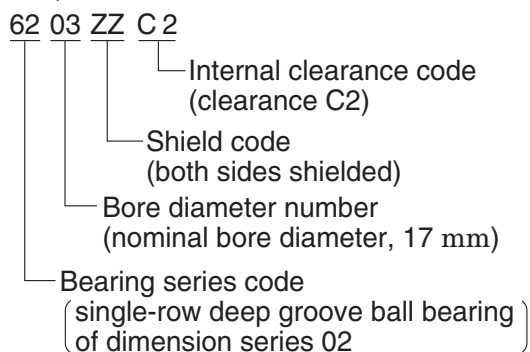

(Ex. 2)

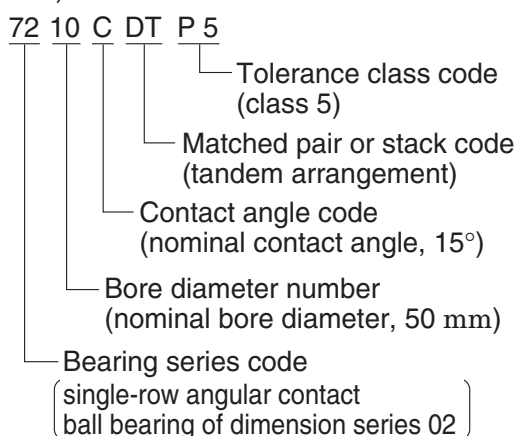

(Ex. 3)

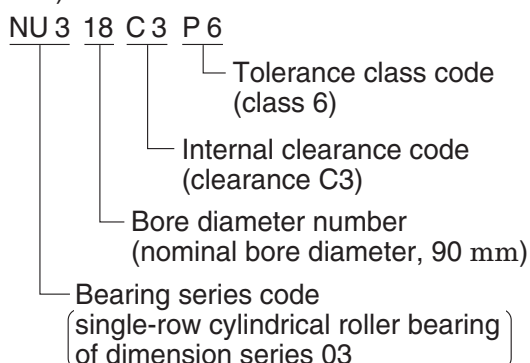

(Ex. 4)

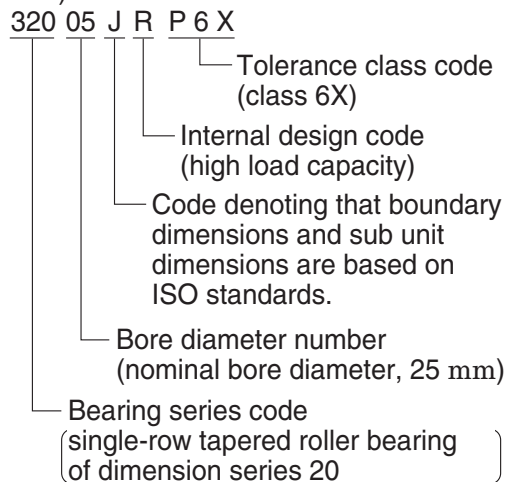

(Ex. 5)

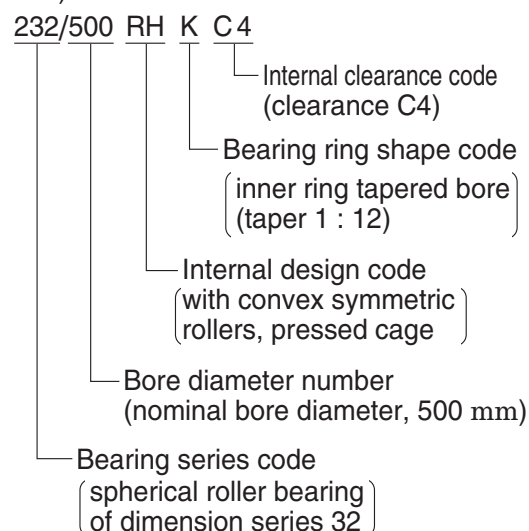

(Ex. 6)

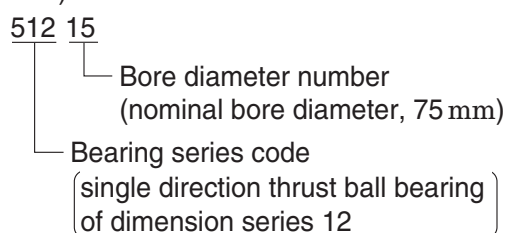

Table 6-1 Bearing series code

Bearing type	Bearing series code	Type code	Dimension series code	
			Width series ¹⁾	Diameter series
Single-row deep groove ball bearing	68	6	(1)	8
	69	6	(1)	9
	160 ²⁾	6	(0)	0
	60	6	(1)	0
	62	6	(0)	2
	63	6	(0)	3
	64	6	(0)	4
Double-row deep groove ball bearing (with filling slot)	42	4	(2)	2
	43	4	(2)	3
Single-row angular contact ball bearing	79	7	(1)	9
	70	7	(1)	0
	72	7	(0)	2
	73	7	(0)	3
	74	7	(0)	4
Double-row angular contact ball bearing (with filling slot)	32	(0)	3	2
	33	(0)	3	3
Double-row angular contact ball bearing	52	5	(3)	2
	53	5	(3)	3
Self-aligning ball bearing	12	1	(0)	2
	22	2	(2)	2
	13	1	(0)	3
	23	2	(2)	3
	112 ²⁾	1	(0) ³⁾	2
	113 ²⁾	1	(0) ³⁾	3
Single-row cylindrical roller bearing	NU 10	NU ⁴⁾	1	0
	NU 2	NU ⁴⁾	(0)	2
	NU 22	NU ⁴⁾	2	2
	NU 32	NU ⁴⁾	3	2
	NU 3	NU ⁴⁾	(0)	3
	NU 23	NU ⁴⁾	2	3
	NU 4	NU ⁴⁾	(0)	4
Double-row cylindrical roller bearing	NNU 49	NNU	4	9
	NN 30	NN	3	0
Single-row needle roller bearing	NA 48	NA	4	8
	NA 49	NA	4	9
	NA 59	NA	5	9
Double-row needle roller bearing	NA 69	NA	6	9

Bearing type	Bearing series code	Type code	Dimension series code	
			Width series	Diameter series
Tapered roller bearing	329	3	2	9
	320	3	2	0
	330	3	3	0
	331	3	3	1
	302	3	0	2
	322	3	2	2
	332	3	3	2
	303	3	0	3
	313	3	1	3
	323	3	2	3
Spherical roller bearing	239	2	3	9
	230	2	3	0
	240	2	4	0
	231	2	3	1
	241	2	4	1
	222	2	2	2
	232	2	3	2
	213 ²⁾	2	0	3
	223	2	2	3
		511	5	1
Single direction thrust ball bearing	512	5	1	2
	513	5	1	3
	514	5	1	4
		532	5	3
Single direction thrust ball bearing with spherical back face	533	5	3	3
	534	5	3	4
		522	5	2
Double direction thrust ball bearing	523	5	2	3
	524	5	2	4
		542	5	4
Double direction thrust ball bearing with spherical back faces	543	5	4	3
	544	5	4	4
		292	2	9
Spherical thrust roller bearing	293	2	9	3
	294	2	9	4

[Notes]

- 1) Width series codes in parentheses are omitted in bearing series codes.
- 2) These are bearing series codes customarily used.
- 3) Nominal outer ring width series (inner rings only are wide).
- 4) Besides NU type, NJ, NUP, N, NF, and NH are provided.

code						
Material code, special treatment code	Matched pair or stack code	Internal clearance code, preload code	Spacer code	Cage material/ shape code	Tolerance code	Grease code

(Codes and descriptions)

- NY** Creep prevention synthetic resin ring on outer ring outside surface provided
- SG** Spiral groove on inner ring bore surface provided
- W** Lubrication hole and lubrication groove on cylindrical roller bearing outer ring outside surface provided
- W33** Lubrication hole and lubrication groove on spherical roller bearing outer ring outside surface provided

- CM** Radial internal clearance for electric motor bearing (Deep groove ball bearing)
- CT** (Cylindrical roller bearing)

NA Non-interchangeable cylindrical roller bearing radial internal clearance (C1NA to C5NA)

- S** Slight preload
- L** Light preload
- M** Medium preload (Preload for angular contact ball bearing)
- H** Heavy preload

Material code, special treatment code

Code not given High carbon chrome bearing steel

- E** } Case carburizing steel
- F** }
- H** }
- Y** }

ST Stainless steel

SH Special heat treatment

- S0** Up to 150 °C (Dimension stabilizing treatment)
- S1** Up to 200 °C
- S2** Up to 250 °C

Matched pair or stack code, cage guide code

- DB** Back-to-back arrangement (Angular contact ball bearing)
- DF** Face-to-face arrangement
- DT** Tandem arrangement

PA With outer ring guide cage (Ball bearing)

Q3 With roller guide cage (Roller bearing)

Internal clearance code, preload code

- C1** Smaller than C2
- C2** Smaller than standard clearance (Radial internal clearance for radial bearing)
- CN** Standard clearance
- C3** Greater than standard clearance
- C4** Greater than C3
- C5** Greater than C4
- M1 to M6** (Radial internal clearance for extra-small/miniature ball bearing)
- CD2** Smaller than standard clearance (Radial internal clearance for double-row angular contact ball bearing)
- CDN** Standard clearance
- CD3** Greater than standard clearance

Spacer code (Spacer width (mm) is affixed to the end of each code.)

- +** Inner and outer ring spacers provided (Deep groove ball bearing)
- /** Inner and outer ring spacers provided (Angular contact ball bearing)
- /P** Outer ring spacer provided
- /S** Inner ring spacer provided
- +DP** Inner and outer ring spacers provided (Cylindrical roller bearing, spherical roller bearing)
- +IDP** Inner ring spacer provided
- +ODP** Outer ring spacer provided

Cage material/type code

- //** Steel sheet (Pressed cage)
- YS** Stainless steel sheet
- FT** Phenol resin
- FY** High-tensile brass casting (Machined cage)
- FW** High-tensile brass casting (separable type)
- MG** } Polyamide (Molded cage)
- FG** }
- FP** Carbon steel (Pin type cage)

Tolerance code (JIS)

- Omitted Class 0
- P6** Class 6
- P6X** Class 6X
- P5** Class 5
- P4** Class 4
- P2** Class 2

Grease code

- A2** Alvania 2
- AC** Andok C
- B5** Beacon 325
- SR** Multemp SRL

7. Bearing tolerances

7-1 Tolerances and tolerance classes for bearings

Bearing tolerances and permissible values for the boundary dimensions and running accuracy of bearings are specified.

These values are prescribed in JIS B 1514 "tolerances for rolling bearings." (These JIS standards are based on ISO standards.)

Bearing tolerances are standardized by classifying bearings into the following six classes (accuracy in tolerances becomes higher in the order described): 0, 6X, 6, 5, 4 and 2.

Class 0 bearings offer adequate performance for general applications; and, bearings of class 5 or higher are required for demanding applications and operating conditions including those described in Table 7-1.

These tolerances follow ISO standards, but some countries use different names for them. Tolerances for each bearing class, and organizations concerning bearings are listed in Table 7-2.

- Boundary dimension accuracy
 - (items on shaft and housing mounting dimensions)
 - Tolerances for bore diameter, outside diameter, ring width, assembled bearing width
 - Tolerances for set bore diameter and set outside diameter of rollers
 - Tolerance limits for chamfer dimensions
 - Permissible values for width variation
 - Tolerance and permissible values for tapered bore
- Running accuracy
 - (items on runout of rotating elements)
 - Permissible values for radial and axial runout of inner and outer rings
 - Permissible values for perpendicularity of inner ring face
 - Permissible values for perpendicularity of outer ring outside surface
 - Permissible values for thrust bearing raceway thickness

Accuracies for dimensions and running of each bearing type are listed in Tables 7-3 through 7-10; and, tolerances for tapered bore and limit values for chamfer dimensions of radial bearings are in Tables 7-11 and 7-12.

Table 7-1 High precision bearing applications

Required performance	Applications	Tolerance class
High accuracy in runout is required for rolling elements.	Acoustic / visual equipment spindles (VTR, tape recorders)	P 5, P 4
	Radar / parabola antenna slewing shafts	P 4
	Machine tool spindles	P 5, P 4, P 2, ABEC 9
	Computers, magnetic disc spindles	P 5, P 4, P 2, ABEC 9
	Aluminum foil roll necks	P 5
	Multi-stage mill backing bearings	P 4
High speed rotation	Dental spindles	P 2, ABMA 5P, ABMA 7P
	Superchargers	P 5, P 4
	Jet engine spindles and accessories	P 5, P 4
	Centrifugal separators	P 5, P 4
	LNG pumps	P 5
	Turbo molecular pump spindles and touch-down	P 5, P 4
	Machine tool spindles	P 5, P 4, P 2, ABEC 9
Tension reels	P 5, P 4	
Low friction or low friction variation is required.	Control equipment (synchronous motors, servomotors, gyro gimbals)	P 4, ABMA 7P
	Measuring instruments	P 5
	Machine tool spindles	P 5, P 4, P 2, ABEC 9

Table 7-2 Bearing type and tolerance class

Bearing type		Applied standards	Applied tolerance class						Tolerance table	
Deep groove ball bearing		JIS B 1514-1	Class 0	–	Class 6	Class 5	Class 4	Class 2	Table 7-3	
Angular contact ball bearing			Class 0	–	Class 6	Class 5	Class 4	Class 2		
Self-aligning ball bearing			Class 0	–	–	–	–	–		
Cylindrical roller bearing			Class 0	–	Class 6	Class 5	Class 4	Class 2		
Needle roller bearing (machined ring type)		JIS B 1536-1	Class 0	–	–	–	–	–		
Tapered roller bearing	Metric series (single-row)	JIS B 1514-1	Class 0	Class 6X	(Class 6)	Class 5	Class 4	Class 2	Table 7-5	
	Metric series (double or four-row)	BAS 1002	Class 0	–	–	–	–	–	Table 7-6	
	Inch series	ANSI/ABMA	Class 4	–	Class 2	Class 3	Class 0	Class 00	Table 7-7	
	Metric series (J-series)		Class PK	–	Class PN	Class PC	Class PB	–	Table 7-8	
Spherical roller bearing		JIS B 1514-1	Class 0	–	–	–	–	–	Table 7-3	
Thrust ball bearing		JIS B 1514-2	Class 0	–	Class 6	Class 5	Class 4	–	Table 7-9	
Spherical thrust roller bearing			Class 0	–	–	–	–	–	Table 7-10	
Precision ball screw support bearing		JTEKT standards	–	–	–	Class P5Z	Class P4Z	–	–	
Double direction angular contact thrust ball bearing			–	–	–	Equivalent to class 5	Equivalent to class 4	–	–	
(Reference) Class comparison	ISO	Radial bearing	ISO 492	Normal Class	Class 6X	Class 6	Class 5	Class 4	Class 2	–
		Thrust bearing	ISO 199	Normal Class	–	Class 6	Class 5	Class 4	–	–
	DIN BS NF	Radial and thrust bearings	DIN 620 BS 6107 NF E 22-335	Normal Class	Class 6X	Class 6	Class 5	Class 4	Class 2	–
	ANSI ABMA	Radial bearing	ABMA std. 20	ABEC 1 RBEC 1	– –	ABEC 3 RBEC 3	ABEC 5 RBEC 5	ABEC 7 –	ABEC 9 –	–
		Instrument ball bearing	ABMA std. 12	–	–	Class 3P	Class 5P Class 5T	Class 7P Class 7T	Class 9P	Table 7-4
		Tapered roller bearing	ABMA std. 19	Class 4 Class K	– –	Class 2 Class N	Class 3 Class C	Class 0 Class B	Class 00 Class A	Table 7-7

(Reference) Standards and organizations concerned with bearings

- JIS : Japanese Industrial Standard
- BAS : The Japan Bearing Industrial Association Standard
- ISO : International Organization for Standardization
- ANSI : American National Standards Institute, Inc.
- ABMA : American Bearing Manufactures Association
- DIN : Deutsches Institut für Normung
- BS : British Standards Institution
- NF : Association Francaise de Normalisation

Table 7-3 (1) Radial bearing tolerances (tapered roller bearings excluded)

= JIS B 1514-1 =

(1) Inner ring (bore diameter)

Nominal bore diameter <i>d</i> mm		Single plane mean bore diameter deviation Δ_{dmp}										Single bore diameter deviation $\Delta_{ds}^{1)}$				Single plane Diameter series 7, 8, 9			
		class 0		class 6		class 5		class 4		class 2		class 4		class 2		class 0	class 6	class 5	class 4
		upper	lower	upper	lower	upper	lower	upper	lower	upper	lower	upper	lower	upper	lower	max.			
–	0.6	0	– 8	0	– 7	0	– 5	0	– 4	0	– 2.5	0	– 4	0	– 2.5	10	9	5	4
0.6	2.5	0	– 8	0	– 7	0	– 5	0	– 4	0	– 2.5	0	– 4	0	– 2.5	10	9	5	4
2.5	10	0	– 8	0	– 7	0	– 5	0	– 4	0	– 2.5	0	– 4	0	– 2.5	10	9	5	4
10	18	0	– 8	0	– 7	0	– 5	0	– 4	0	– 2.5	0	– 4	0	– 2.5	10	9	5	4
18	30	0	– 10	0	– 8	0	– 6	0	– 5	0	– 2.5	0	– 5	0	– 2.5	13	10	6	5
30	50	0	– 12	0	– 10	0	– 8	0	– 6	0	– 2.5	0	– 6	0	– 2.5	15	13	8	6
50	80	0	– 15	0	– 12	0	– 9	0	– 7	0	– 4	0	– 7	0	– 4	19	15	9	7
80	120	0	– 20	0	– 15	0	– 10	0	– 8	0	– 5	0	– 8	0	– 5	25	19	10	8
120	150	0	– 25	0	– 18	0	– 13	0	– 10	0	– 7	0	– 10	0	– 7	31	23	13	10
150	180	0	– 25	0	– 18	0	– 13	0	– 10	0	– 7	0	– 10	0	– 7	31	23	13	10
180	250	0	– 30	0	– 22	0	– 15	0	– 12	0	– 8	0	– 12	0	– 8	38	28	15	12
250	315	0	– 35	0	– 25	0	– 18	0	– 15	–	–	0	– 15	–	–	44	31	18	15
315	400	0	– 40	0	– 30	0	– 23	0	– 18	–	–	0	– 18	–	–	50	38	23	18
400	500	0	– 45	0	– 35	0	– 28	0	– 23	–	–	0	– 23	–	–	56	44	28	23
500	630	0	– 50	0	– 40	0	– 35	–	–	–	–	–	–	–	–	63	50	35	–
630	800	0	– 75	0	– 50	0	– 45	–	–	–	–	–	–	–	–	94	63	45	–
800	1 000	0	– 100	0	– 60	0	– 60	–	–	–	–	–	–	–	–	125	75	60	–
1 000	1 250	0	– 125	0	– 75	0	– 75	–	–	–	–	–	–	–	–	156	94	75	–
1 250	1 600	0	– 160	–	–	–	–	–	–	–	–	–	–	–	–	200	–	–	–
1 600	2 000	0	– 200	–	–	–	–	–	–	–	–	–	–	–	–	250	–	–	–

(2) Inner ring (running accuracy and width)

Nominal bore diameter <i>d</i> mm		Radial runout of assembled bearing inner ring K_{ia}										Single inner ring width Δ_{Bs}												
		class 0		class 6		class 5		class 4		class 2		class 5		class 4		class 2		class 0		class 6		class 5		
		upper	lower	upper	lower	upper	lower	upper	lower	upper	lower	upper	lower	upper	lower	upper	lower	upper	lower	upper	lower	upper	lower	
–	0.6	10	5	4	2.5	1.5	7	3	1.5	7	3	1.5	0	– 40	0	– 40	0	– 40	0	– 40	0	– 40	0	– 40
0.6	2.5	10	5	4	2.5	1.5	7	3	1.5	7	3	1.5	0	– 40	0	– 40	0	– 40	0	– 40	0	– 40	0	– 40
2.5	10	10	6	4	2.5	1.5	7	3	1.5	7	3	1.5	0	– 120	0	– 120	0	– 40	0	– 40	0	– 40	0	– 40
10	18	10	7	4	2.5	1.5	7	3	1.5	7	3	1.5	0	– 120	0	– 120	0	– 80	0	– 80	0	– 80	0	– 80
18	30	13	8	4	3	2.5	8	4	1.5	8	4	2.5	0	– 120	0	– 120	0	– 120	0	– 120	0	– 120	0	– 120
30	50	15	10	5	4	2.5	8	4	1.5	8	4	2.5	0	– 120	0	– 120	0	– 120	0	– 120	0	– 120	0	– 120
50	80	20	10	5	4	2.5	8	5	1.5	8	5	2.5	0	– 150	0	– 150	0	– 150	0	– 150	0	– 150	0	– 150
80	120	25	13	6	5	2.5	9	5	2.5	9	5	2.5	0	– 200	0	– 200	0	– 200	0	– 200	0	– 200	0	– 200
120	150	30	18	8	6	2.5	10	6	2.5	10	7	2.5	0	– 250	0	– 250	0	– 250	0	– 250	0	– 250	0	– 250
150	180	30	18	8	6	5	10	6	4	10	7	5	0	– 250	0	– 250	0	– 250	0	– 250	0	– 250	0	– 250
180	250	40	20	10	8	5	11	7	5	13	8	5	0	– 300	0	– 300	0	– 300	0	– 300	0	– 300	0	– 300
250	315	50	25	13	10	–	13	8	–	15	9	–	0	– 350	0	– 350	0	– 350	0	– 350	0	– 350	0	– 350
315	400	60	30	15	13	–	15	9	–	20	12	–	0	– 400	0	– 400	0	– 400	0	– 400	0	– 400	0	– 400
400	500	65	35	20	15	–	18	11	–	25	15	–	0	– 450	0	– 450	0	– 450	0	– 450	0	– 450	0	– 450
500	630	70	40	25	–	–	25	–	–	30	–	–	0	– 500	0	– 500	0	– 500	0	– 500	0	– 500	0	– 500
630	800	80	50	30	–	–	30	–	–	35	–	–	0	– 750	0	– 750	0	– 750	0	– 750	0	– 750	0	– 750
800	1 000	90	60	40	–	–	40	–	–	45	–	–	0	– 1 000	0	– 1 000	0	– 1 000	0	– 1 000	0	– 1 000	0	– 1 000
1 000	1 250	100	70	50	–	–	50	–	–	60	–	–	0	– 1 250	0	– 1 250	0	– 1 250	0	– 1 250	0	– 1 250	0	– 1 250
1 250	1 600	120	–	–	–	–	–	–	–	–	–	–	0	– 1 600	–	–	–	–	–	–	–	–	–	–
1 600	2 000	140	–	–	–	–	–	–	–	–	–	–	0	– 2 000	–	–	–	–	–	–	–	–	–	–

S_d : perpendicularity of inner ring face with respect to the bore S_{ia} : axial runout of assembled bearing inner ring

[Notes] 1) These shall be applied to bearings of diameter series 0, 1, 2, 3 and 4.

2) These shall be applied to deep groove ball bearings and angular contact ball bearings.

Unit : μm

bore diameter variation V_{dsp}									Mean bore diameter variation					Nominal bore diameter d mm	
Diameter series 0, 1				Diameter series 2, 3, 4				Dia. series ¹⁾ class 2	V_{dmp}						
class 0	class 6	class 5	class 4	class 0	class 6	class 5	class 4		class 0	class 6	class 5	class 4	class 2		
max.				max.				max.	max.					over	up to
8	7	4	3	6	5	4	3	2.5	6	5	3	2	1.5	—	0.6
8	7	4	3	6	5	4	3	2.5	6	5	3	2	1.5	0.6	2.5
8	7	4	3	6	5	4	3	2.5	6	5	3	2	1.5	2.5	10
8	7	4	3	6	5	4	3	2.5	6	5	3	2	1.5	10	18
10	8	5	4	8	6	5	4	2.5	8	6	3	2.5	1.5	18	30
12	10	6	5	9	8	6	5	2.5	9	8	4	3	1.5	30	50
19	15	7	5	11	9	7	5	4	11	9	5	3.5	2	50	80
25	19	8	6	15	11	8	6	5	15	11	5	4	2.5	80	120
31	23	10	8	19	14	10	8	7	19	14	7	5	3.5	120	150
31	23	10	8	19	14	10	8	7	19	14	7	5	3.5	150	180
38	28	12	9	23	17	12	9	8	23	17	8	6	4	180	250
44	31	14	11	26	19	14	11	—	26	19	9	8	—	250	315
50	38	18	14	30	23	18	14	—	30	23	12	9	—	315	400
56	44	21	17	34	26	21	17	—	34	26	14	12	—	400	500
63	50	26	—	38	30	26	—	—	38	30	18	—	—	500	630
94	63	34	—	56	38	34	—	—	56	38	23	—	—	630	800
125	75	45	—	75	45	45	—	—	75	45	30	—	—	800	1 000
156	94	56	—	94	56	56	—	—	94	56	38	—	—	1 000	1 250
200	—	—	—	120	—	—	—	—	120	—	—	—	—	1 250	1 600
250	—	—	—	150	—	—	—	—	150	—	—	—	—	1 600	2 000

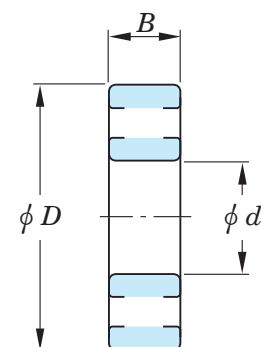

Cylindrical bore

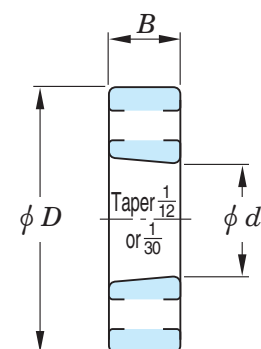

Tapered bore

 Unit : μm

deviation		Single inner ring width deviation $\Delta_{Bs}^{3)}$										Inner ring width variation V_{Bs}					Nominal bore diameter d mm	
class 4		class 2		class 0 ⁴⁾		class 6 ⁴⁾		class 5 ⁴⁾		classes 4, 2		class 0	class 6	class 5	class 4	class 2		
upper	lower	upper	lower	upper	lower	upper	lower	upper	lower	upper	lower	max.						
0	-40	0	-40	—	—	—	—	0	-250	0	-250	12	12	5	2.5	1.5	—	0.6
0	-40	0	-40	—	—	—	—	0	-250	0	-250	12	12	5	2.5	1.5	0.6	2.5
0	-40	0	-40	0	-250	0	-250	0	-250	0	-250	15	15	5	2.5	1.5	2.5	10
0	-80	0	-80	0	-250	0	-250	0	-250	0	-250	20	20	5	2.5	1.5	10	18
0	-120	0	-120	0	-250	0	-250	0	-250	0	-250	20	20	5	2.5	1.5	18	30
0	-120	0	-120	0	-250	0	-250	0	-250	0	-250	20	20	5	3	1.5	30	50
0	-150	0	-150	0	-380	0	-380	0	-250	0	-250	25	25	6	4	1.5	50	80
0	-200	0	-200	0	-380	0	-380	0	-380	0	-380	25	25	7	4	2.5	80	120
0	-250	0	-250	0	-500	0	-500	0	-380	0	-380	30	30	8	5	2.5	120	150
0	-250	0	-250	0	-500	0	-500	0	-380	0	-380	30	30	8	5	4	150	180
0	-300	0	-300	0	-500	0	-500	0	-500	0	-500	30	30	10	6	5	180	250
0	-350	—	—	0	-500	0	-500	0	-500	—	—	35	35	13	8	—	250	315
0	-400	—	—	0	-630	0	-630	0	-630	—	—	40	40	15	9	—	315	400
0	-450	—	—	—	—	—	—	—	—	—	—	50	45	18	11	—	400	500
—	—	—	—	—	—	—	—	—	—	—	—	60	50	20	—	—	500	630
—	—	—	—	—	—	—	—	—	—	—	—	70	60	23	—	—	630	800
—	—	—	—	—	—	—	—	—	—	—	—	80	60	35	—	—	800	1 000
—	—	—	—	—	—	—	—	—	—	—	—	100	60	45	—	—	1 000	1 250
—	—	—	—	—	—	—	—	—	—	—	—	120	—	—	—	—	1 250	1 600
—	—	—	—	—	—	—	—	—	—	—	—	140	—	—	—	—	1 600	2 000

3) These shall be applied to individual bearing rings manufactured for matched pair or stack bearings.

 4) Also applicable to the inner ring with tapered bore of $d \geq 50$ mm.

[Remark] Values in Italics are prescribed in JTEKT standards.

Table 7-3 (2) Radial bearing tolerances (tapered roller bearings excluded)

(3) Outer ring (outside diameter)

Nominal outside dia. <i>D</i> mm		Single plane mean outside diameter deviation Δ_{Dmp}										Single outside diameter deviation $\Delta_{Ds}^{1)}$				Single plane			
																Diameter series 7, 8, 9			
		class 0		class 6		class 5		class 4		class 2		class 4 ⁵⁾		class 2		class 0 ²⁾	class 6 ³⁾	class 5 ⁵⁾	class 4 ⁵⁾
over	up to	upper	lower	upper	lower	upper	lower	upper	lower	upper	lower	upper	lower	upper	lower	max.			
-	2.5	0	- 8	0	- 7	0	- 5	0	- 4	0	- 2.5	0	- 4	0	- 2.5	10	9	5	4
2.5	6	0	- 8	0	- 7	0	- 5	0	- 4	0	- 2.5	0	- 4	0	- 2.5	10	9	5	4
6	18	0	- 8	0	- 7	0	- 5	0	- 4	0	- 2.5	0	- 4	0	- 2.5	10	9	5	4
18	30	0	- 9	0	- 8	0	- 6	0	- 5	0	- 4	0	- 5	0	- 4	12	10	6	5
30	50	0	- 11	0	- 9	0	- 7	0	- 6	0	- 4	0	- 6	0	- 4	14	11	7	6
50	80	0	- 13	0	- 11	0	- 9	0	- 7	0	- 4	0	- 7	0	- 4	16	14	9	7
80	120	0	- 15	0	- 13	0	- 10	0	- 8	0	- 5	0	- 8	0	- 5	19	16	10	8
120	150	0	- 18	0	- 15	0	- 11	0	- 9	0	- 5	0	- 9	0	- 5	23	19	11	9
150	180	0	- 25	0	- 18	0	- 13	0	- 10	0	- 7	0	- 10	0	- 7	31	23	13	10
180	250	0	- 30	0	- 20	0	- 15	0	- 11	0	- 8	0	- 11	0	- 8	38	25	15	11
250	315	0	- 35	0	- 25	0	- 18	0	- 13	0	- 8	0	- 13	0	- 8	44	31	18	13
315	400	0	- 40	0	- 28	0	- 20	0	- 15	0	- 10	0	- 15	0	- 10	50	35	20	15
400	500	0	- 45	0	- 33	0	- 23	0	- 17	-	-	0	- 17	-	-	56	41	23	17
500	630	0	- 50	0	- 38	0	- 28	0	- 20	-	-	0	- 20	-	-	63	48	28	20
630	800	0	- 75	0	- 45	0	- 35	-	-	-	-	-	-	-	-	94	56	35	-
800	1 000	0	- 100	0	- 60	0	- 50	-	-	-	-	-	-	-	-	125	75	50	-
1 000	1 250	0	- 125	0	- 75	0	- 63	-	-	-	-	-	-	-	-	156	94	63	-
1 250	1 600	0	- 160	0	- 90	0	- 80	-	-	-	-	-	-	-	-	200	113	80	-
1 600	2 000	0	- 200	0	- 120	-	-	-	-	-	-	-	-	-	-	250	150	-	-
2 000	2 500	0	- 250	-	-	-	-	-	-	-	-	-	-	-	-	313	-	-	-

(4) Outer ring (running accuracy and width)

Unit : μm

Nominal outside dia. <i>D</i> mm		Radial runout of assembled bearing outer ring K_{ea}					$S_D^{4)}$			$S_{ea}^{3)4)}$			$\Delta_{Cs}^{3)}$		Ring width variation $V_{Cs}^{3)}$			
		class 0	class 6	class 5	class 4	class 2	class 5	class 4	class 2	class 5	class 4	class 2	classes 0, 6, 5, 4, 2		classes 0, 6	class 5	class 4	class 2
		over	up to	max.					max.			max.			upper	lower	max.	
-	2.5	15	8	5	3	1.5	8	4	1.5	8	5	1.5	Shall conform to the tolerance Δ_{Bs} on <i>d</i> of the same bearing	Shall conform to the tolerance V_{Bs} on <i>d</i> of the same bearing	5	2.5	1.5	
2.5	6	15	8	5	3	1.5	8	4	1.5	8	5	1.5			5	2.5	1.5	
6	18	15	8	5	3	1.5	8	4	1.5	8	5	1.5			5	2.5	1.5	
18	30	15	9	6	4	2.5	8	4	1.5	8	5	2.5			5	2.5	1.5	
30	50	20	10	7	5	2.5	8	4	1.5	8	5	2.5			5	2.5	1.5	
50	80	25	13	8	5	4	8	4	1.5	10	5	4			6	3	1.5	
80	120	35	18	10	6	5	9	5	2.5	11	6	5			8	4	2.5	
120	150	40	20	11	7	5	10	5	2.5	13	7	5			8	5	2.5	
150	180	45	23	13	8	5	10	5	2.5	14	8	5			8	5	2.5	
180	250	50	25	15	10	7	11	7	4	15	10	7			10	7	4	
250	315	60	30	18	11	7	13	8	5	18	10	7			11	7	5	
315	400	70	35	20	13	8	13	10	7	20	13	8			13	8	7	
400	500	80	40	23	15	-	15	12	-	23	15	-			15	9	-	
500	630	100	50	25	18	-	18	13	-	25	18	-			18	11	-	
630	800	120	60	30	-	-	20	-	-	30	-	-			20	-	-	
800	1 000	140	75	40	-	-	23	-	-	40	-	-			23	-	-	
1 000	1 250	160	85	45	-	-	30	-	-	45	-	-	30	-	-			
1 250	1 600	190	95	60	-	-	45	-	-	60	-	-	45	-	-			
1 600	2 000	220	110	-	-	-	-	-	-	-	-	-	-	-	-			
2 000	2 500	250	-	-	-	-	-	-	-	-	-	-	-	-	-			

S_D : perpendicularity of outer ring outside surface with respect to the face

S_{ea} : axial runout of assembled bearing outer ring

Δ_{Cs} : deviation of a single outer ring width

outside diameter variation V_{Dsp}										Shielded/sealed type		Mean outside diameter variation V_{Dmp}					Nominal outside dia. D mm	
Diameter series 0, 1				Diameter series 2, 3, 4				Dia. series	Diameter series							over	up to	
class 0 ²⁾	class 6 ²⁾	class 5 ⁵⁾	class 4 ⁵⁾	class 0 ²⁾	class 6 ²⁾	class 5 ⁵⁾	class 4 ⁵⁾		class 2	class 0 ²⁾	class 6 ²⁾	class 0 ²⁾	class 6 ²⁾	class 5	class 4			class 2
max.				max.				max.	max.		max.							
8	7	4	3	6	5	4	3	2.5	10	9	6	5	3	2	1.5	–	2.5	
8	7	4	3	6	5	4	3	2.5	10	9	6	5	3	2	1.5	2.5	6	
8	7	4	3	6	5	4	3	2.5	10	9	6	5	3	2	1.5	6	18	
9	8	5	4	7	6	5	4	4	12	10	7	6	3	2.5	2	18	30	
11	9	5	5	8	7	5	5	4	16	13	8	7	4	3	2	30	50	
13	11	7	5	10	8	7	5	4	20	16	10	8	5	3.5	2	50	80	
19	16	8	6	11	10	8	6	5	26	20	11	10	5	4	2.5	80	120	
23	19	8	7	14	11	8	7	5	30	25	14	11	6	5	2.5	120	150	
31	23	10	8	19	14	10	8	7	38	30	19	14	7	5	3.5	150	180	
38	25	11	8	23	15	11	8	8	–	–	23	15	8	6	4	180	250	
44	31	14	10	26	19	14	10	8	–	–	26	19	9	7	4	250	315	
50	35	15	11	30	21	15	11	10	–	–	30	21	10	8	5	315	400	
56	41	17	<i>13</i>	34	25	17	<i>13</i>	–	–	–	34	25	12	9	–	400	500	
63	48	21	<i>15</i>	38	29	21	<i>15</i>	–	–	–	38	29	14	<i>10</i>	–	500	630	
94	56	26	–	55	34	26	–	–	–	–	55	34	18	–	–	630	800	
125	75	38	–	75	45	38	–	–	–	–	75	45	25	–	–	800	1 000	
<i>156</i>	<i>94</i>	<i>47</i>	–	<i>94</i>	<i>56</i>	<i>47</i>	–	–	–	–	<i>94</i>	<i>56</i>	<i>31</i>	–	–	1 000	1 250	
<i>200</i>	<i>113</i>	<i>60</i>	–	<i>120</i>	<i>68</i>	<i>60</i>	–	–	–	–	<i>120</i>	<i>68</i>	<i>40</i>	–	–	1 250	1 600	
<i>250</i>	<i>150</i>	–	–	<i>150</i>	<i>90</i>	–	–	–	–	–	<i>150</i>	<i>90</i>	–	–	–	1 600	2 000	
<i>313</i>	–	–	–	<i>188</i>	–	–	–	–	–	–	<i>188</i>	–	–	–	–	2 000	2 500	

[Notes]

- 1) These shall be applied to bearings of diameter series 0, 1, 2, 3 and 4.
- 2) Shall be applied when locating snap ring is not fitted.
- 3) These shall be applied to deep groove ball bearings and angular contact ball bearings.
- 4) These shall not be applied to flanged bearings.
- 5) These shall not be applied to shielded bearings and sealed bearings.

[Remark]

Values in Italics are prescribed in JTEKT standards.

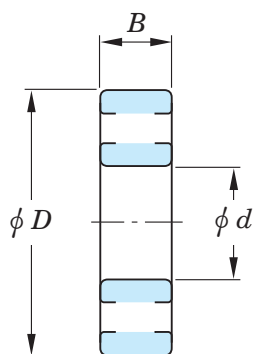

Cylindrical bore

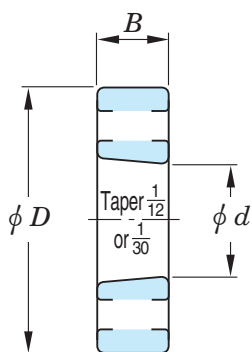

Tapered bore

d : nominal bore diameter
 D : nominal outside diameter
 B : nominal assembled bearing width

7. Bearing tolerances

(Refer.) Table 7-4 Tolerances for measuring instrument ball bearings (inch series)

= ANSI/ABMA standards = (reference)

(1) Inner ring and outer ring width

Nominal bore dia. <i>d</i> mm		Single plane mean bore diameter deviation Δ_{dmp}				Single bore diameter deviation Δ_{ds}				Single plane bore diameter variation V_{dsp}		Mean bore diameter variation V_{dmp}		Radial runout of assembled bearing inner ring K_{ia}		
		classes 5P, 7P		class 9P		classes 5P, 7P		class 9P		classes 5P, 7P	class 9P	classes 5P, 7P	class 9P	class 5P	class 7P	class 9P
over	up to	upper	lower	upper	lower	upper	lower	upper	lower	max.		max.		max.		
-	10	0	-5.1	0	-2.5	0	-5.1	0	-2.5	2.5	1.3	2.5	1.3	3.8	2.5	1.3
10	18	0	-5.1	0	-2.5	0	-5.1	0	-2.5	2.5	1.3	2.5	1.3	3.8	2.5	1.3
18	30	0	-5.1	0	-2.5	0	-5.1	0	-2.5	2.5	1.3	2.5	1.3	3.8	3.8	2.5

(2) Outer ring

Nominal outside dia. <i>D</i> mm		Single plane mean outside diameter deviation Δ_{Dmp}				Single outside diameter deviation Δ_{Ds}				Single plane outside diameter variation V_{Dsp}			Mean outside diameter variation V_{Dmp}				
		classes 5P, 7P		class 9P		classes 5P, 7P		class 9P		classes 5P, 7P		class 9P	classes 5P, 7P		class 9P		
		Open type	Shielded/ sealed type	Open type	Open type	Open type	Shielded/ sealed type	Open type	Open type	Open type	Open type	Shielded/ sealed type	Open type				
over	up to	upper	lower	upper	lower	upper	lower	upper	lower	upper	lower	max.		max.			
-	18	0	-5.1	0	-2.5	0	-5.1	+1	-6.1	0	-2.5	2.5	5.1	1.3	2.5	5.1	1.3
18	30	0	-5.1	0	-3.8	0	-5.1	+1	-6.1	0	-3.8	2.5	5.1	2	2.5	5.1	2
30	50	0	-5.1	0	-3.8	0	-5.1	+1	-6.1	0	-3.8	2.5	5.1	2	2.5	5.1	2

Unit : μm

Axial runout of assembled bearing inner ring S_{ia}			Perpendicularity of inner ring face with respect to the bore S_d			Single inner or outer ring width deviation Δ_{Bs}, Δ_{Cs}		Inner or outer ring width variation V_{Bs}, V_{Cs}		
class 5P	class 7P	class 9P	class 5P	class 7P	class 9P	classes 5P, 7P, 9P		class 5P	class 7P	class 9P
max.			max.			upper	lower	max.		
7.6	2.5	1.3	7.6	2.5	1.3	0	-25.4	5.1	2.5	1.3
7.6	2.5	1.3	7.6	2.5	1.3	0	-25.4	5.1	2.5	1.3
7.6	3.8	1.3	7.6	3.8	1.3	0	-25.4	5.1	2.5	1.3

Unit : μm

Radial runout of assembled bearing outer ring K_{ea}			Axial runout of assembled bearing outer ring S_{ea}			Perpendicularity of outer ring outside surface with respect to the face S_D			Single outer ring flange outside diameter deviation Δ_{D1s}		Single outer ring flange width deviation Δ_{C1s}	
class 5P	class 7P	class 9P	class 5P	class 7P	class 9P	class 5P	class 7P	class 9P	classes 5P, 7P		classes 5P, 7P	
max.			max.			max.			upper	lower	upper	lower
5.1	3.8	1.3	7.6	5.1	1.3	7.6	3.8	1.3	0	-25.4	0	-50.8
5.1	3.8	2.5	7.6	5.1	2.5	7.6	3.8	1.3	0	-25.4	0	-50.8
5.1	5.1	2.5	7.6	5.1	2.5	7.6	3.8	1.3	0	-25.4	0	-50.8

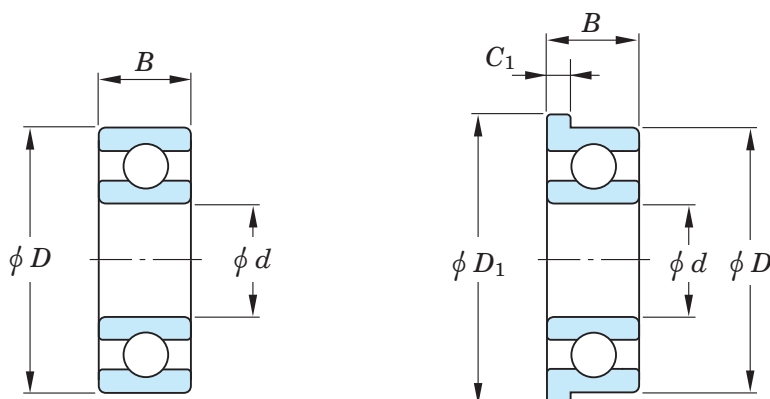

d : nominal bore diameter
 D : nominal outside diameter
 B : nominal assembled bearing width
 D_1 : nominal outer ring flange outside diameter
 C_1 : nominal outer ring flange width

7. Bearing tolerances

Table 7-5 (1) Tolerances for metric series tapered roller bearings
= JIS B 1514-1 =

(1) Inner ring

Nominal bore diameter d mm		Single plane mean bore diameter deviation Δ_{dmp}								Single bore diameter deviation Δ_{ds}				Single plane bore diameter variation V_{dsp}					Mean bore diameter variation V_{dmp}				
		classes 0, 6X		classes 6, 5		class 4		class 2		class 4		class 2		classes 0, 6X	class 6	class 5	class 4	class 2	classes 0, 6X	class 6	class 5	class 4	class 2
		upper	lower	upper	lower	upper	lower	upper	lower	upper	lower	upper	lower	upper	lower	max.					max.		
–	10	0	– 12	0	– 7 ¹⁾	0	– 5	0	– 4	0	– 5	0	– 4	12	–	5	4	2.5	9	–	5	4	1.5
10	18	0	– 12	0	– 7	0	– 5	0	– 4	0	– 5	0	– 4	12	7	5	4	2.5	9	5	5	4	1.5
18	30	0	– 12	0	– 8	0	– 6	0	– 4	0	– 6	0	– 4	12	8	6	5	2.5	9	6	5	4	1.5
30	50	0	– 12	0	– 10	0	– 8	0	– 5	0	– 8	0	– 5	12	10	8	6	3	9	8	5	5	2
50	80	0	– 15	0	– 12	0	– 9	0	– 5	0	– 9	0	– 5	15	12	9	7	4	11	9	6	5	2
80	120	0	– 20	0	– 15	0	– 10	0	– 6	0	– 10	0	– 6	20	15	11	8	5	15	11	8	5	2.5
120	180	0	– 25	0	– 18	0	– 13	0	– 7	0	– 13	0	– 7	25	18	14	10	7	19	14	9	7	3.5
180	250	0	– 30	0	– 22	0	– 15	0	– 8	0	– 15	0	– 8	30	22	17	11	7	23	16	11	8	4
250	315	0	– 35	0	– 25 ¹⁾	0	– 18	0	– 8	0	– 18	0	– 8	35	25	19	12	8	26	19	13	9	5
315	400	0	– 40	0	– 30 ¹⁾	–	–	–	–	–	–	–	–	40	30	23	–	–	30	23	15	–	–
400	500	0	– 45	0	– 35 ¹⁾	–	–	–	–	–	–	–	–	45	35	28	–	–	34	26	17	–	–
500	630	0	– 60	0	– 40 ¹⁾	–	–	–	–	–	–	–	–	60	40	35	–	–	40	30	20	–	–
630	800	0	– 75	0	– 50 ¹⁾	–	–	–	–	–	–	–	–	75	50	45	–	–	45	38	25	–	–
800	1 000	0	– 100	0	– 60 ¹⁾	–	–	–	–	–	–	–	–	100	60	60	–	–	55	45	30	–	–

(2-1) Outer ring

Nominal outside diameter D mm		Single plane mean outside diameter deviation Δ_{Dmp}								Single outside diameter deviation Δ_{Ds}				Single plane outside diameter variation V_{Dsp}					Mean outside diameter variation V_{Dmp}				
		classes 0, 6X		classes 6, 5		class 4		class 2		class 4		class 2		classes 0, 6X	class 6	class 5	class 4	class 2	classes 0, 6X	class 6	class 5	class 4	class 2
		upper	lower	upper	lower	upper	lower	upper	lower	upper	lower	upper	lower	upper	lower	max.					max.		
–	18	0	– 12	0	– 8 ¹⁾	0	– 6	0	– 5	0	– 6	0	– 5	12	–	6	5	4	9	–	5	4	2.5
18	30	0	– 12	0	– 8	0	– 6	0	– 5	0	– 6	0	– 5	12	8	6	5	4	9	6	5	4	2.5
30	50	0	– 14	0	– 9	0	– 7	0	– 5	0	– 7	0	– 5	14	9	7	5	4	11	7	5	5	2.5
50	80	0	– 16	0	– 11	0	– 9	0	– 6	0	– 9	0	– 6	16	11	8	7	4	12	8	6	5	2.5
80	120	0	– 18	0	– 13	0	– 10	0	– 6	0	– 10	0	– 6	18	13	10	8	5	14	10	7	5	3
120	150	0	– 20	0	– 15	0	– 11	0	– 7	0	– 11	0	– 7	20	15	11	8	5	15	11	8	6	3.5
150	180	0	– 25	0	– 18	0	– 13	0	– 7	0	– 13	0	– 7	25	18	14	10	7	19	14	9	7	4
180	250	0	– 30	0	– 20	0	– 15	0	– 8	0	– 15	0	– 8	30	20	15	11	8	23	15	10	8	5
250	315	0	– 35	0	– 25	0	– 18	0	– 9	0	– 18	0	– 9	35	25	19	14	8	26	19	13	9	5
315	400	0	– 40	0	– 28	0	– 20	0	– 10	0	– 20	0	– 10	40	28	22	15	10	30	21	14	10	6
400	500	0	– 45	0	– 33 ¹⁾	–	–	–	–	–	–	–	–	45	33	26	–	–	34	25	17	–	–
500	630	0	– 50	0	– 38 ¹⁾	–	–	–	–	–	–	–	–	60	38	30	–	–	38	29	20	–	–
630	800	0	– 75	0	– 45 ¹⁾	–	–	–	–	–	–	–	–	80	45	38	–	–	55	34	25	–	–
800	1 000	0	– 100	0	– 60 ¹⁾	–	–	–	–	–	–	–	–	100	60	50	–	–	75	45	30	–	–
1 000	1 250	0	– 125	0	– 80 ¹⁾	–	–	–	–	–	–	–	–	130	75	65	–	–	90	56	38	–	–
1 250	1 600	0	– 160	0	– 100 ¹⁾	–	–	–	–	–	–	–	–	170	90	90	–	–	100	68	50	–	–

- [Notes] 1) Class 6 values are prescribed in JTEKT standards.
 2) These shall be applied to bearings of tolerance class 5.
 3) These shall not be applied to flanged bearings.

[Remark] Values in Italics are prescribed in JTEKT standards.

Unit : μm

Radial runout of assembled bearing inner ring K_{ia}					S_d					S_{ia}					Single inner ring width deviation Δ_{Bs}										Nominal bore diameter d mm											
classes 0, 6X					class 6					class 5					class 4					class 2					class 0		class 6X		class 6		classes 5, 4		class 2		over	up to
max.					max.					max.					upper	lower	upper	lower	upper	lower	upper	lower	upper	lower	upper	lower	upper	lower	over	up to						
15	—	5	3	2	7	3	1.5	3	2	0	—	120	0	—	50	—	—	0	—	200	0	—	200	—	—	—	—	—	—	10						
15	7	5	3	2	7	3	1.5	3	2	0	—	120	0	—	50	0	—	120	0	—	200	0	—	200	0	—	200	0	—	18						
18	8	5	3	2.5	8	4	1.5	4	2.5	0	—	120	0	—	50	0	—	120	0	—	200	0	—	200	0	—	200	0	—	30						
20	10	6	4	2.5	8	4	2	4	2.5	0	—	120	0	—	50	0	—	120	0	—	240	0	—	240	0	—	240	0	—	50						
25	10	7	4	3	8	5	2	4	3	0	—	150	0	—	50	0	—	150	0	—	300	0	—	300	0	—	300	0	—	80						
30	13	8	5	3	9	5	2.5	5	3	0	—	200	0	—	50	0	—	200	0	—	400	0	—	400	0	—	400	0	—	120						
35	18	11	6	4	10	6	3.5	7	4	0	—	250	0	—	50	0	—	250	0	—	500	0	—	500	0	—	500	0	—	180						
50	20	13	8	5	11	7	5	8	5	0	—	300	0	—	50	0	—	300	0	—	600	0	—	600	0	—	600	0	—	250						
60	30	13	9	6	13	8	5.5	9	6	0	—	350	0	—	50	0	—	350	0	—	700	0	—	700	0	—	700	0	—	315						
70	35	15	—	—	15	—	—	—	—	0	—	400	0	—	50	0	—	400	0	—	800 ⁽²⁾	—	—	—	—	—	—	—	—	400						
80	40	20	—	—	17	—	—	—	—	0	—	450	0	—	50	0	—	450	0	—	900 ⁽²⁾	—	—	—	—	—	—	—	—	500						
90	50	25	—	—	20	—	—	—	—	0	—	500	—	—	0	—	500	0	—	1 100 ⁽²⁾	—	—	—	—	—	—	—	—	630							
100	60	30	—	—	25	—	—	—	—	0	—	750	—	—	0	—	750	0	—	1 600 ⁽²⁾	—	—	—	—	—	—	—	—	800							
115	75	37	—	—	30	—	—	—	—	0	—	1 000	—	—	0	—	1 000	0	—	2 000 ⁽²⁾	—	—	—	—	—	—	—	—	1 000							

S_d : perpendicularity of inner ring face with respect to the bore

S_{ia} : axial runout of assembled bearing inner ring

Unit : μm (2-2) Outer ring Unit : μm

Radial runout of assembled bearing outer ring K_{ea}					$S_D^{(3)}$					$S_{ea}^{(3)}$					Nominal outside diameter D mm						
classes 0, 6X					class 6					class 5					class 4					over	up to
max.					max.					max.					over	up to					
18	—	6	4	2.5	8	4	1.5	5	2.5	—	—	—	—	—	—	18					
18	9	6	4	2.5	8	4	1.5	5	2.5	18	30	18	30	18	30	30					
20	10	7	5	2.5	8	4	2	5	2.5	30	50	30	50	30	50	50					
25	13	8	5	4	8	4	2.5	5	4	50	80	50	80	50	80	80					
35	18	10	6	5	9	5	3	6	5	80	120	80	120	80	120	120					
40	20	11	7	5	10	5	3.5	7	5	120	150	120	150	120	150	150					
45	23	13	8	5	10	5	4	8	5	150	180	150	180	150	180	180					
50	25	15	10	7	11	7	5	10	7	180	250	180	250	180	250	250					
60	30	18	11	7	13	8	6	10	7	250	315	250	315	250	315	315					
70	35	20	13	8	13	10	7	13	8	315	400	315	400	315	400	400					
80	40	24	—	—	17	—	—	—	—	400	500	400	500	400	500	500					
100	50	30	—	—	20	—	—	—	—	500	630	500	630	500	630	630					
120	60	36	—	—	25	—	—	—	—	630	800	630	800	630	800	800					
140	75	43	—	—	30	—	—	—	—	800	1 000	800	1 000	800	1 000	1 000					
160	85	52	—	—	38	—	—	—	—	1 000	1 250	1 000	1 250	1 000	1 250	1 250					
180	95	62	—	—	50	—	—	—	—	1 250	1 600	1 250	1 600	1 250	1 600	1 600					

S_D : perpendicularity of outer ring outside surface with respect to the face

S_{ea} : axial runout of assembled bearing outer ring

Nominal bore diameter d mm		Single outer ring width deviation Δ_{Cs}					
		class 6X		classes 0, 6, 5, 4, 2			
over	up to	upper	lower	upper	lower	upper	lower
—	10	0	—	—	—	—	—
10	18	0	—	—	—	—	—
18	30	0	—	—	—	—	—
30	50	0	—	—	—	—	—
50	80	0	—	—	—	—	—
80	120	0	—	—	—	—	—
120	180	0	—	—	—	—	—
180	250	0	—	—	—	—	—
250	315	0	—	—	—	—	—
315	400	0	—	—	—	—	—
400	500	0	—	—	—	—	—
500	630	—	—	—	—	—	—
630	800	—	—	—	—	—	—
800	1 000	—	—	—	—	—	—

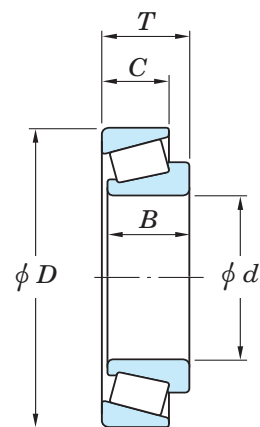

d : nominal bore diameter
 D : nominal outside diameter
 B : nominal inner ring width
 C : nominal outer ring width
 T : nominal assembled bearing width

Table 7-5 (2) Tolerances for metric series tapered roller bearings

(3) Assembled bearing width and effective width

Unit : μm

Nominal bore diameter d mm		Actual bearing width deviation ΔT_s										Actual effective inner sub-unit width deviation ΔT_{1s}							
		class 0		class 6X		class 6		classes 5, 4		class 2		class 0		class 6X		classes 5, 4		class 2	
over	up to	upper	lower	upper	lower	upper	lower	upper	lower	upper	lower	upper	lower	upper	lower	upper	lower	upper	lower
–	10	+200	0	+100	0	–	–	+200	–200	+200	–200	+100	0	+50	0	+100	–100	+100	–100
10	18	+200	0	+100	0	+200	0	+200	–200	+200	–200	+100	0	+50	0	+100	–100	+100	–100
18	30	+200	0	+100	0	+200	0	+200	–200	+200	–200	+100	0	+50	0	+100	–100	+100	–100
30	50	+200	0	+100	0	+200	0	+200	–200	+200	–200	+100	0	+50	0	+100	–100	+100	–100
50	80	+200	0	+100	0	+200	0	+200	–200	+200	–200	+100	0	+50	0	+100	–100	+100	–100
80	120	+200	–200	+100	0	+200	–200	+200	–200	+200	–200	+100	–100	+50	0	+100	–100	+100	–100
120	180	+350	–250	+150	0	+350	–250	+350	–250	+200	–250	+150	–150	+50	0	+150	–150	+100	–100
180	250	+350	–250	+150	0	+350	–250	+350	–250	+200	–300	+150	–150	+50	0	+150	–150	+100	–150
250	315	+350	–250	+200	0	+350	–250	+350	–250	+200	–300	+150	–150	+100	0	+150	–150	+100	–150
315	400	+400	–400	+200	0	+400	–400 ¹⁾	+400	–400 ¹⁾	–	–	+200	–200	+100	0	+200	–200 ¹⁾	–	–
400	500	+450	–450	+200	0	+400	–400	+450	–450 ¹⁾	–	–	+225	–225	+100	0	+225	–225 ¹⁾	–	–
500	630	+500	–500	–	–	+500	–500 ¹⁾	+500	–500 ¹⁾	–	–	–	–	–	–	–	–	–	–
630	800	+600	–600	–	–	+600	–600 ¹⁾	+600	–600 ¹⁾	–	–	–	–	–	–	–	–	–	–
800	1 000	+750	–750	–	–	+750	–750 ¹⁾	+750	–750 ¹⁾	–	–	–	–	–	–	–	–	–	–

Nominal bore diameter d mm		Actual effective outer ring width deviation ΔT_{2s}							
		class 0		class 6X		classes 5, 4		class 2	
over	up to	upper	lower	upper	lower	upper	lower	upper	lower
–	10	+100	0	+50	0	+100	–100	+100	–100
10	18	+100	0	+50	0	+100	–100	+100	–100
18	30	+100	0	+50	0	+100	–100	+100	–100
30	50	+100	0	+50	0	+100	–100	+100	–100
50	80	+100	0	+50	0	+100	–100	+100	–100
80	120	+100	–100	+50	0	+100	–100	+100	–100
120	180	+200	–100	+100	0	+200	–100	+100	–150
180	250	+200	–100	+100	0	+200	–100	+100	–150
250	315	+200	–100	+100	0	+200	–100	+100	–150
315	400	+200	–200	+100	0	+200	–200 ¹⁾	–	–
400	500	+225	–225	+100	0	+225	–225 ¹⁾	–	–
500	630	–	–	–	–	–	–	–	–
630	800	–	–	–	–	–	–	–	–
800	1 000	–	–	–	–	–	–	–	–

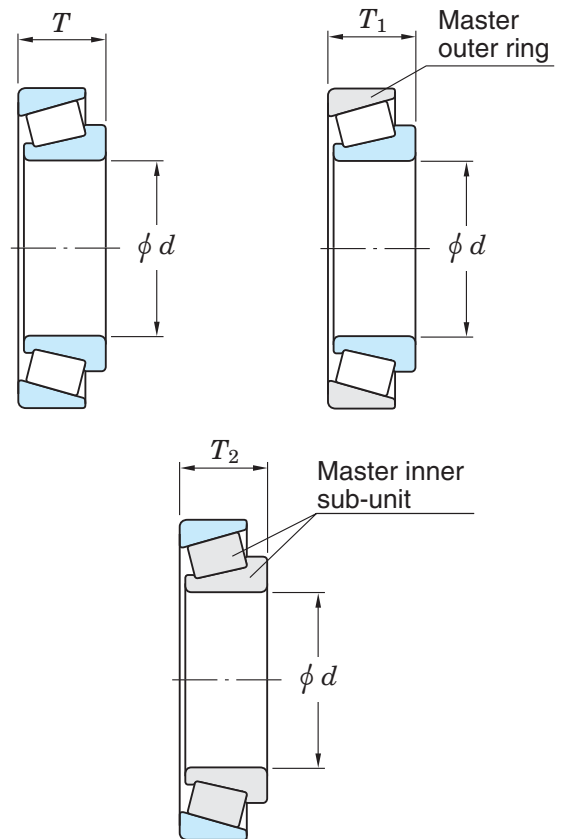

[Note] 1) These shall be applied to bearings of tolerance class 5.

[Remark] Values in Italics are prescribed in JTEKT standards.

d : nominal bore diameter

T : nominal assembled bearing width

T_1 : nominal effective width of inner sub-unit

T_2 : nominal effective width of outer ring

Table 7-6 Tolerances for metric series double-row and four-row tapered roller bearings (class 0) = BAS 1002 =

(1) Inner ring, outer ring width and overall width

Unit : μm

Nominal bore diameter d mm		Single plane mean bore diameter deviation Δ_{dmp}		Single plane bore diameter variation V_{dsp}	Mean bore diameter variation V_{dmp}	K_{ia}	Single outer ring or inner ring width deviation Δ_{Bs}, Δ_{Cs}		Actual overall inner rings/outer rings width deviation			
									Double-row Δ_{Ts}		Four-row Δ_{Ts}, Δ_{Ws}	
over	up to	upper	lower	max.	max.	max.	upper	lower	upper	lower	upper	lower
30	50	0	-12	12	9	20	0	-120	+240	-240	-	-
50	80	0	-15	15	11	25	0	-150	+300	-300	-	-
80	120	0	-20	20	15	30	0	-200	+400	-400	+500	-500
120	180	0	-25	25	19	35	0	-250	+500	-500	+600	-600
180	250	0	-30	30	23	50	0	-300	+600	-600	+750	-750
250	315	0	-35	35	26	60	0	-350	+700	-700	+900	-900
315	400	0	-40	40	30	70	0	-400	+800	-800	+1000	-1000
400	500	0	-45	45	34	80	0	-450	+900	-900	+1200	-1200
500	630	0	-60	60	40	90	0	-500	+1000	-1000	+1200	-1200
630	800	0	-75	75	45	100	0	-750	+1500	-1500	-	-
800	1000	0	-100	100	55	115	0	-1000	+1500	-1500	-	-

K_{ia} : radial runout of assembled bearing inner ring

(2) Outer ring

Unit : μm

Nominal outside diameter D mm		Single plane mean outside diameter deviation Δ_{Dmp}		Single plane outside diameter variation V_{Dsp}	Mean outside diameter variation V_{Dmp}	K_{ea}
50	80	0	-16	16	12	25
80	120	0	-18	18	14	35
120	150	0	-20	20	15	40
150	180	0	-25	25	19	45
180	250	0	-30	30	23	50
250	315	0	-35	35	26	60
315	400	0	-40	40	30	70
400	500	0	-45	45	34	80
500	630	0	-50	60	38	100
630	800	0	-75	80	55	120
800	1000	0	-100	100	75	140
1000	1250	0	-125	130	90	160
1250	1600	0	-160	170	100	180

K_{ea} : radial runout of assembled bearing outer ring

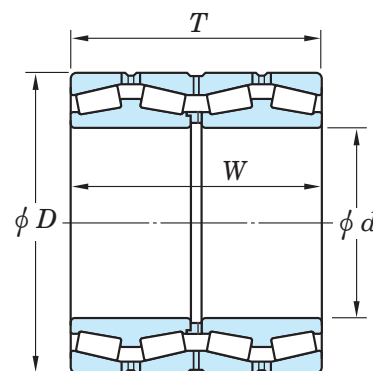
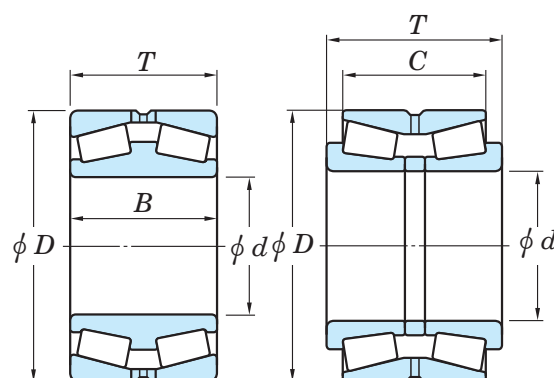

- d : nominal bore diameter
- D : nominal outside diameter
- B : nominal double inner ring width
- C : nominal double outer ring width
- T, W : nominal overall width of outer rings (inner rings)

7. Bearing tolerances

Table 7-7 Tolerances and permissible values for inch series tapered roller bearings
= ANSI/ABMA 19 =

(1) Inner ring

Unit : μm

Applied bearing type	Nominal bore diameter d , mm (1/25.4)		Deviation of a single bore diameter Δ_{ds}									
			class 4		class 2		class 3		class 0		class 00	
	over	up to	upper	lower	upper	lower	upper	lower	upper	lower	upper	lower
All types	–	76.2 (3.0)	+ 13	0	+13	0	+13	0	+13	0	+8	0
	76.2 (3.0)	266.7 (10.5)	+ 25	0	+25	0	+13	0	+13	0	+8	0
	266.7 (10.5)	304.8 (12.0)	+ 25	0	+25	0	+13	0	+13	0	+8	0
	304.8 (12.0)	609.6 (24.0)	+ 51	0	+51	0	+25	0	–	–	–	–
	609.6 (24.0)	914.4 (36.0)	+ 76	0	–	–	+38	0	–	–	–	–
	914.4 (36.0)	1 219.2 (48.0)	+102	0	–	–	+51	0	–	–	–	–
	1 219.2 (48.0)	–	+127	0	–	–	+76	0	–	–	–	–

(2) Outer ring

Unit : μm

Applied bearing type	Nominal outside diameter D , mm (1/25.4)		Deviation of a single outside diameter Δ_{Ds}									
			class 4		class 2		class 3		class 0		class 00	
	over	up to	upper	lower	upper	lower	upper	lower	upper	lower	upper	lower
All types	–	266.7 (10.5)	+ 25	0	+25	0	+13	0	+13	0	+8	0
	266.7 (10.5)	304.8 (12.0)	+ 25	0	+25	0	+13	0	+13	0	+8	0
	304.8 (12.0)	609.6 (24.0)	+ 51	0	+51	0	+25	0	–	–	–	–
	609.6 (24.0)	914.4 (36.0)	+ 76	0	+76	0	+38	0	–	–	–	–
	914.4 (36.0)	1 219.2 (48.0)	+102	0	–	–	+51	0	–	–	–	–
	1 219.2 (48.0)	–	+127	0	–	–	+76	0	–	–	–	–

(3) Radial runout of assembled bearing inner ring/outer ring

Unit : μm

Applied bearing type	Nominal outside diameter D , mm (1/25.4)		Radial runout of inner ring/outer ring K_{ia}, K_{ea}				
			class 4	class 2	class 3	class 0	class 00
	over	up to	max.	max.	max.	max.	max.
All types	–	266.7 (10.5)	51	38	8	4	2
	266.7 (10.5)	304.8 (12.0)	51	38	8	4	2
	304.8 (12.0)	609.6 (24.0)	51	38	18	–	–
	609.6 (24.0)	914.4 (36.0)	76	51	51	–	–
	914.4 (36.0)	1 219.2 (48.0)	76	–	76	–	–
	1 219.2 (48.0)	–	76	–	76	–	–

(4) Assembled bearing width and overall width

Unit : μm

Applied bearing type	Nominal bore diameter d , mm (1/25.4)		Nominal outside diameter D , mm (1/25.4)		Deviation of the actual bearing width and overall width of inner rings/outer rings $\Delta T_s, \Delta W_s$							
	over	up to	over	up to	class 4		class 2		class 3		classes 0,00	
					upper	lower	upper	lower	upper	lower	upper	lower
Single-row	-	101.6 (4.0)	-	-	+ 203	0	+ 203	0	+ 203	- 203	+ 203	- 203
	101.6 (4.0)	266.7 (10.5)	-	-	+ 356	- 254	+ 203	0	+ 203	- 203	+ 203	- 203
	266.7 (10.5)	304.8 (12.0)	-	-	+ 356	- 254	+ 203	0	+ 203	- 203	+ 203	- 203 ¹⁾
	304.8 (12.0)	609.6 (24.0)	-	508.0 (20.0)	-	-	+ 381	- 381	+ 203	- 203	-	-
	304.8 (12.0)	609.6 (24.0)	508.0 (20.0)	-	-	-	+ 381	- 381	+ 381	- 381	-	-
	609.6 (24.0)	-	-	-	+ 381	- 381	-	-	+ 381	- 381	-	-
Double-row	-	101.6 (4.0)	-	-	+ 406	0	+ 406	0	+ 406	- 406	+ 406	- 406
	101.6 (4.0)	266.7 (10.5)	-	-	+ 711	- 508	+ 406	- 203	+ 406	- 406	+ 406	- 406
	266.7 (10.5)	304.8 (12.0)	-	-	+ 711	- 508	+ 406	- 203	+ 406	- 406	+ 406	- 406 ¹⁾
	304.8 (12.0)	609.6 (24.0)	-	508.0 (20.0)	-	-	+ 762	- 762	+ 406	- 406	-	-
	304.8 (12.0)	609.6 (24.0)	508.0 (20.0)	-	-	-	+ 762	- 762	+ 762	- 762	-	-
	609.6 (24.0)	-	-	-	+ 762	- 762	-	-	+ 762	- 762	-	-
Double-row (TNA type)	-	127.0 (5.0)	-	-	-	-	+ 254	0	+ 254	0	-	-
	127.0 (5.0)	-	-	-	-	-	+ 762	0	+ 762	0	-	-
Four-row	Total dimensional range		-	-	+1 524	-1 524	+1 524	-1 524	+1 524	-1 524	+1 524	-1 524

[Note] 1) These shall be applied to bearings of class 0.

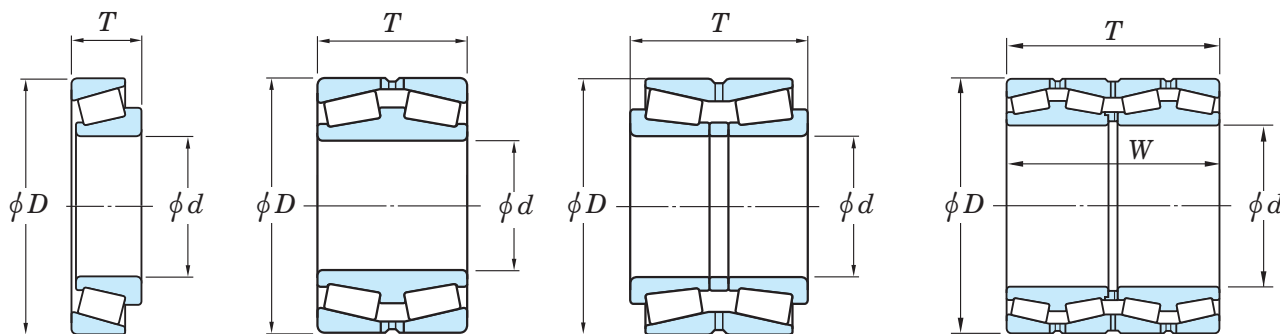

d : nominal bore diameter
 D : nominal outside diameter
 T, W : nominal assembled bearing width and nominal overall width of outer rings (inner rings)

7. Bearing tolerances

Table 7-8 Tolerances for metric J series tapered roller bearings¹⁾

(1) Bore diameter and width of inner ring and assembled bearing width

Nominal bore diameter d mm		Deviation of a single bore diameter Δ_{ds}								Deviation of a single inner ring width Δ_{Bs}							
		class PK		class PN		class PC		class PB		class PK		class PN		class PC		class PB	
over	up to	upper	lower	upper	lower	upper	lower	upper	lower	upper	lower	upper	lower	upper	lower	upper	lower
10	18	0	-12	0	-12	0	-7	0	-5	0	-100	0	-50	0	-200	0	-200
18	30	0	-12	0	-12	0	-8	0	-6	0	-100	0	-50	0	-200	0	-200
30	50	0	-12	0	-12	0	-10	0	-8	0	-100	0	-50	0	-200	0	-200
50	80	0	-15	0	-15	0	-12	0	-9	0	-150	0	-50	0	-300	0	-300
80	120	0	-20	0	-20	0	-15	0	-10	0	-150	0	-50	0	-300	0	-300
120	180	0	-25	0	-25	0	-18	0	-13	0	-200	0	-50	0	-300	0	-300
180	250	0	-30	0	-30	0	-22	0	-15	0	-200	0	-50	0	-350	0	-350
250	315	0	-35	0	-35	0	-22	0	-15	0	-200	0	-50	0	-350	0	-350

(2) Outside diameter and width of outer ring and radial runout of assembled bearing inner ring/outer ring

Nominal outside diameter D mm		Deviation of a single outside diameter Δ_{Ds}								Deviation of a single outer ring width Δ_{Cs}							
		class PK		class PN		class PC		class PB		class PK		class PN		class PC		class PB	
over	up to	upper	lower	upper	lower	upper	lower	upper	lower	upper	lower	upper	lower	upper	lower	upper	lower
18	30	0	-12	0	-12	0	-8	0	-6	0	-150	0	-100	0	-150	0	-150
30	50	0	-14	0	-14	0	-9	0	-7	0	-150	0	-100	0	-150	0	-150
50	80	0	-16	0	-16	0	-11	0	-9	0	-150	0	-100	0	-150	0	-150
80	120	0	-18	0	-18	0	-13	0	-10	0	-200	0	-100	0	-200	0	-200
120	150	0	-20	0	-20	0	-15	0	-11	0	-200	0	-100	0	-200	0	-200
150	180	0	-25	0	-25	0	-18	0	-13	0	-200	0	-100	0	-250	0	-250
180	250	0	-30	0	-30	0	-20	0	-15	0	-250	0	-100	0	-250	0	-250
250	315	0	-35	0	-35	0	-25	0	-18	0	-250	0	-100	0	-300	0	-300
315	400	0	-40	0	-40	0	-28	-	-	0	-250	0	-100	0	-300	-	-

[Note] 1) Bearings with supplementary code "J" attached at the front of bearing number
Ex. JHM720249/JHM720210, and the like

Unit : μm

Deviation of the actual bearing width Δ_{Ts}									Nominal bore diameter d mm	
class PK		class PN		class PC		class PB		over		
upper	lower	upper	lower	upper	lower	upper	lower			
+200	0	+100	0	+200	-200	+200	-200	10	18	
+200	0	+100	0	+200	-200	+200	-200	18	30	
+200	0	+100	0	+200	-200	+200	-200	30	50	
+200	0	+100	0	+200	-200	+200	-200	50	80	
+200	-200	+100	0	+200	-200	+200	-200	80	120	
+350	-250	+150	0	+350	-250	+200	-250	120	180	
+350	-250	+150	0	+350	-250	+200	-300	180	250	
+350	-250	+200	0	+350	-300	+200	-300	250	315	

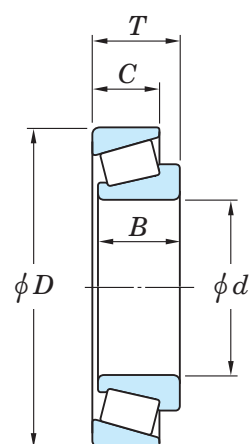

d : nominal bore diameter

D : nominal outside diameter

B : nominal inner ring width

C : nominal outer ring width

T : nominal assembled bearing width

Unit : μm

Radial runout of inner ring/outer ring K_{ia}, K_{ea}					Nominal outside diameter D mm	
class PK	class PN	class PC	class PB	over		
max.	max.	max.	max.			
18	18	5	3	18	30	
20	20	6	3	30	50	
25	25	6	4	50	80	
35	35	6	4	80	120	
40	40	7	4	120	150	
45	45	8	4	150	180	
50	50	10	5	180	250	
60	60	11	5	250	315	
70	70	13	-	315	400	

Table 7-9 Tolerances for thrust ball bearings = JIS B 1514-2 =

(1) Shaft race and central race

Unit : μm

Nominal bore diameter of shaft or central race d or d_2 , mm		Single plane mean bore diameter deviation Δ_{dmp} or Δ_{d2mp}				Single plane bore diameter variation V_{dsp} or V_{d2sp}		Race raceway to back face thickness variation $S_i^{1) 2)}$			
		classes 0, 6, 5		class 4		classes 0, 6, 5	class 4	class 0	class 6	class 5	class 4
over	up to	upper	lower	upper	lower	max.		max.			
–	18	0	– 8	0	– 7	6	5	10	5	3	2
18	30	0	– 10	0	– 8	8	6	10	5	3	2
30	50	0	– 12	0	– 10	9	8	10	6	3	2
50	80	0	– 15	0	– 12	11	9	10	7	4	3
80	120	0	– 20	0	– 15	15	11	15	8	4	3
120	180	0	– 25	0	– 18	19	14	15	9	5	4
180	250	0	– 30	0	– 22	23	17	20	10	5	4
250	315	0	– 35	0	– 25	26	19	25	13	7	5
315	400	0	– 40	0	– 30	30	23	30	15	7	5
400	500	0	– 45	0	– 35	34	26	30	18	9	6
500	630	0	– 50	0	– 40	38	30	35	21	11	7
630	800	0	– 75	0	– 50	55	40	40	25	13	8
800	1 000	0	– 100	–	–	75	–	45	30	15	–
1 000	1 250	0	– 125	–	–	95	–	50	35	18	–

- [Notes] 1) Double direction thrust ball bearings shall be included in d of single direction thrust ball bearings of the same diameter series and nominal outside diameter.
2) Applies only to thrust ball bearings and cylindrical roller thrust bearings with 90° contact angle.

(2) Housing race

Unit : μm

Nominal outside diameter D mm		Single plane mean outside diameter deviation Δ_{Dmp}				Single plane outside diameter variation V_{Dsp}		Race raceway to back face thickness variation $S_e^{1) 2)}$	
		classes 0, 6, 5		class 4		classes 0, 6, 5	class 4	classes 0, 6, 5, 4	
over	up to	upper	lower	upper	lower	max.		max.	
10	18	0	– 11	0	– 7	8	5	Shall conform to the tolerance S_i on d or d_2 of the same bearing	
18	30	0	– 13	0	– 8	10	6		
30	50	0	– 16	0	– 9	12	7		
50	80	0	– 19	0	– 11	14	8		
80	120	0	– 22	0	– 13	17	10		
120	180	0	– 25	0	– 15	19	11		
180	250	0	– 30	0	– 20	23	15		
250	315	0	– 35	0	– 25	26	19		
315	400	0	– 40	0	– 28	30	21		
400	500	0	– 45	0	– 33	34	25		
500	630	0	– 50	0	– 38	38	29		
630	800	0	– 75	0	– 45	55	34		
800	1 000	0	– 100	0	– 60	75	45		
1 000	1 250	0	– 125	–	–	95	–		
1 250	1 600	0	– 160	–	–	120	–		

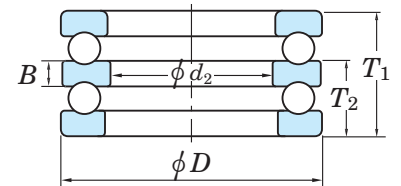
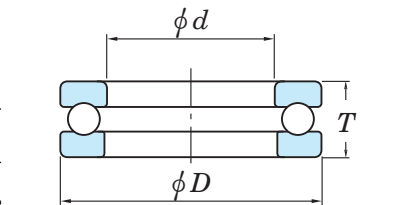

- d : shaft race nominal bore diameter
- d_2 : central race nominal bore diameter
- D : housing race nominal outside diameter
- B : central race nominal height
- T : nominal bearing height (single direction)
- T_1, T_2 : nominal bearing height (double direction)

- [Notes] 1) These shall be applied to race with flat back face only.
2) Applies only to thrust ball bearings and cylindrical roller thrust bearings with 90° contact angle.

(3) Bearing height and central race height

Unit : μm

Nominal bore diameter d mm		Single direction		Double direction					
		Deviation of the actual bearing height Δ_{Ts}		Deviation of the actual bearing height $\Delta_{T1s}^{(1)}$		Deviation of the actual bearing height $\Delta_{T2s}^{(1)}$		Deviation of a single central race height B $\Delta_{Bs}^{(1)}$	
		class 0		class 0		class 0		class 0	
over	up to	upper	lower	upper	lower	upper	lower	upper	lower
-	30	0	- 75	+ 50	- 150	0	- 75	0	- 50
30	50	0	- 100	+ 75	- 200	0	- 100	0	- 75
50	80	0	- 125	+ 100	- 250	0	- 125	0	- 100
80	120	0	- 150	+ 125	- 300	0	- 150	0	- 125
120	180	0	- 175	+ 150	- 350	0	- 175	0	- 150
180	250	0	- 200	+ 175	- 400	0	- 200	0	- 175
250	315	0	- 225	+ 200	- 450	0	- 225	0	- 200
315	400	0	- 300	+ 250	- 600	0	- 300	0	- 250

[Note] 1) Double direction thrust ball bearings shall be included in d of single direction thrust ball bearings of the same diameter series and nominal outside diameter.

[Remark] Values in Italics are prescribed in JTEKT standards.

Table 7-10 Tolerances for spherical thrust roller bearings (class 0) = JIS B 1514-2 =

(1) Shaft race

Unit : μm

Nominal bore diameter d mm		Single plane mean bore diameter deviation Δ_{dmp}		Single plane bore diameter variation V_{dsp}	Refer.			
					S_d	Actual bearing height deviation Δ_{Ts}		
over	up to	upper	lower	max.		max.	upper	lower
50	80	0	- 15	11	25	25	+ 150	- 150
80	120	0	- 20	15	25	25	+ 200	- 200
120	180	0	- 25	19	30	30	+ 250	- 250
180	250	0	- 30	23	30	30	+ 300	- 300
250	315	0	- 35	26	35	35	+ 350	- 350
315	400	0	- 40	30	40	40	+ 400	- 400
400	500	0	- 45	34	45	45	+ 450	- 450

S_d : perpendicularity of inner ring face with respect to the bore

[Remark] Values in Italics are prescribed in JTEKT standards.

(2) Housing race

Unit : μm

Nominal outside diameter D , mm		Single plane mean outside diameter deviation Δ_{Dmp}	
over	up to	upper	lower
120	180	0	- 25
180	250	0	- 30
250	315	0	- 35
315	400	0	- 40
400	500	0	- 45
500	630	0	- 50
630	800	0	- 75
800	1 000	0	- 100

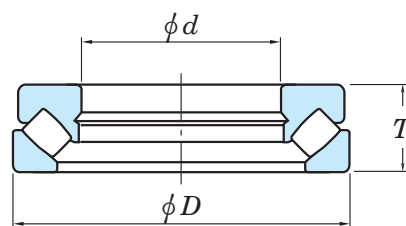

d : shaft race nominal bore diameter

D : housing race nominal outside diameter

T : nominal bearing height

**Table 7-11 Tolerances and permissible values for tapered bores of radial bearings
(class 0 ... JIS B 1514-1)**

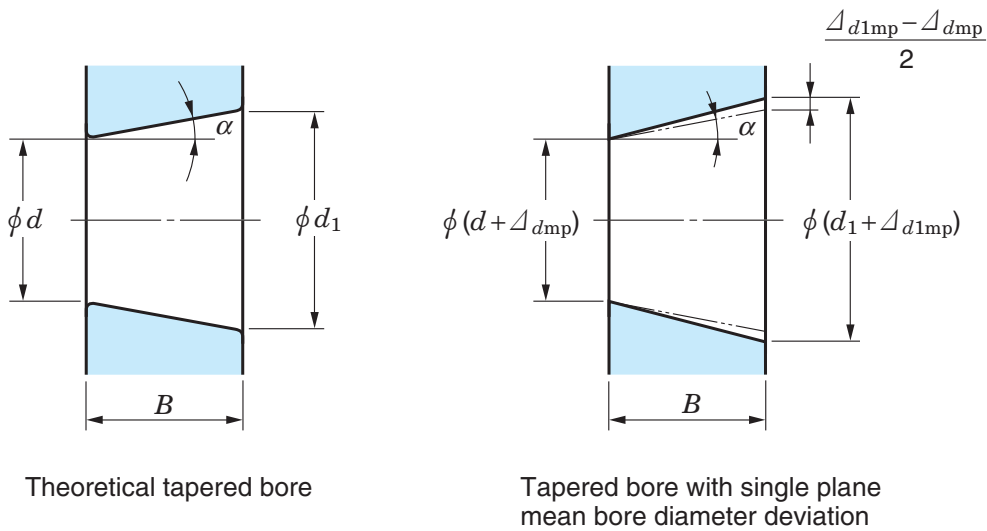

(1) Basically tapered bore (taper 1:12) Unit : μm

Nominal bore diameter <i>d</i> , mm		Δ_{dmp}		$\Delta_{d1mp} - \Delta_{dmp}$		$V_{dsp}^{1)}$
over	up to	upper	lower	upper	lower	max.
-	10	+ 22	0	+ 15	0	9
10	18	+ 27	0	+ 18	0	11
18	30	+ 33	0	+ 21	0	13
30	50	+ 39	0	+ 25	0	16
50	80	+ 46	0	+ 30	0	19
80	120	+ 54	0	+ 35	0	22
120	180	+ 63	0	+ 40	0	40
180	250	+ 72	0	+ 46	0	46
250	315	+ 81	0	+ 52	0	52
315	400	+ 89	0	+ 57	0	57
400	500	+ 97	0	+ 63	0	63
500	630	+ 110	0	+ 70	0	70
630	800	+ 125	0	+ 80	0	-
800	1 000	+ 140	0	+ 90	0	-
1 000	1 250	+ 165	0	+ 105	0	-
1 250	1 600	+ 195	0	+ 125	0	-

(2) Basically tapered bore (taper 1:30) Unit : μm

Nominal bore diameter <i>d</i> , mm		Δ_{dmp}		$\Delta_{d1mp} - \Delta_{dmp}$		$V_{dsp}^{1)}$
over	up to	upper	lower	upper	lower	max.
-	50	+ 15	0	+ 30	0	19
50	80	+ 15	0	+ 30	0	19
80	120	+ 20	0	+ 35	0	22
120	180	+ 25	0	+ 40	0	40
180	250	+ 30	0	+ 46	0	46
250	315	+ 35	0	+ 52	0	52
315	400	+ 40	0	+ 57	0	57
400	500	+ 45	0	+ 63	0	63
500	630	+ 50	0	+ 70	0	70

[Note] 1) These shall be applied to all radial planes with tapered bore, not be applied to bearings of diameter series 7, 8.

[Remark] 1) Symbols of quantity d_1 : reference diameter at theoretical large end of tapered bore

$$d_1 = d + \frac{1}{12}B \text{ or } d_1 = d + \frac{1}{30}B$$

Δ_{dmp} : single plane mean bore diameter deviation at theoretical small end of tapered bore

Δ_{d1mp} : single plane mean bore diameter deviation at theoretical large end of tapered bore

V_{dsp} : single plane bore diameter variation (a tolerance for the diameter variation given by a maximum value applying in any radial plane of the bore)

B : nominal inner ring width

α : $\frac{1}{2}$ of nominal tapered angle of tapered bore

(tapered ratio 1/12)

(tapered ratio 1/30)

$$\alpha = 2^\circ 23' 9.4''$$

$$\alpha = 0^\circ 57' 17.4''$$

$$= 2.38594^\circ$$

$$= 0.95484^\circ$$

$$= 0.041643 \text{ rad}$$

$$= 0.016665 \text{ rad}$$

Table 7-12 Tolerances and permissible values for flanged radial ball bearings

(1) Tolerances on flange outside diameters

Unit : μm

Nominal outer ring flange outside diameter D_1 (mm)		Deviation of single outer ring flange outside diameter, Δ_{D1s}			
		Locating flange		Non-locating flange	
over	up to	upper	lower	upper	lower
—	6	0	-36	+220	-36
6	10	0	-36	+220	-36
10	18	0	-43	+270	-43
18	30	0	-52	+330	-52
30	50	0	-62	+390	-62
50	80	0	-74	+460	-74

(2) Tolerances and permissible values on flange widths and permissible values of running accuracies relating to flanges

Unit : μm

Nominal outside diameter D (mm)		Deviation of single outer ring flange width $\Delta_{C1s}^{1)}$		Variation of outer ring flange width $V_{C1s}^{1)}$			Perpendicularity of outer ring outside surface with respect to the flange back face S_{D1}						Axial runout of assembled bearing outer ring flange back face S_{ea1}					
							Deep groove ball bearings and angular contact ball bearings			Tapered roller bearings			Deep groove ball bearings and angular contact ball bearings			Tapered roller bearings		
							class 5	class 4	class 2	class 5	class 4	class 2	class 5	class 4	class 2	class 5	class 4	class 2
over	up to	upper	lower	max.			max.			max.			max.					
—	2.5	Shall conform to the tolerance Δ_{Bs} on d of the same class and the bearing	Shall conform to the tolerance V_{Bs} on d of the same class and the bearing	5	2.5	1.5	8	4	1.5	8	4	1.5	11	7	3	7	4	
2.5	6			5	2.5	1.5	8	4	1.5	8	4	1.5	11	7	3	7	4	
6	18			5	2.5	1.5	8	4	1.5	8	4	1.5	11	7	3	7	4	
18	30	Shall conform to the tolerance Δ_{Bs} on d of the same class and the bearing	Shall conform to the tolerance V_{Bs} on d of the same class and the bearing	5	2.5	1.5	8	4	1.5	8	4	1.5	11	7	4	7	4	
30	50			5	2.5	1.5	8	4	1.5	8	4	2	11	7	4	7	4	
50	80			6	3	1.5	8	4	1.5	8	4	2.5	14	7	6	7	6	

[Note] 1) These shall be applied to groove ball bearings, i.e. deep groove ball bearing and angular contact ball bearing etc.

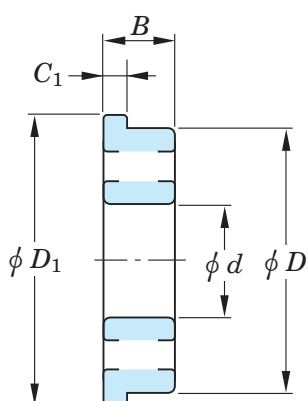

- d : nominal bore diameter
- D : nominal outside diameter
- B : nominal assembled bearing width
- D_1 : nominal outer ring flange outside diameter
- C_1 : nominal outer ring flange width

Table 7-13 Permissible values for chamfer dimensions = JIS B 1514-3 =

(1) Radial bearing

(tapered roller bearings excluded)

Unit : mm

$r_{1 \min}$ or $r_{1 \min}$	Nominal bore diameter d mm		r_{\max} or $r_{1 \max}$	
	over	up to	Radial direction	Axial direction
0.05	–	–	0.1	0.2
0.08	–	–	0.16	0.3
0.1	–	–	0.2	0.4
0.15	–	–	0.3	0.6
0.2	–	–	0.5	0.8
0.3	–	40	0.6	1
	40	–	0.8	1
0.6	–	40	1	2
	40	–	1.3	2
1	–	50	1.5	3
	50	–	1.9	3
1.1	–	120	2	3.5
	120	–	2.5	4
1.5	–	120	2.3	4
	120	–	3	5
2	–	80	3	4.5
	80	220	3.5	5
	220	–	3.8	6
2.1	–	280	4	6.5
	280	–	4.5	7
2.5	–	100	3.8	6
	100	280	4.5	6
3	–	280	5	8
	280	–	5.5	8
4	–	–	6.5	9
5	–	–	8	10
6	–	–	10	13
7.5	–	–	12.5	17
9.5	–	–	15	19
12	–	–	18	24
15	–	–	21	30
19	–	–	25	38

[Remarks]

- Value of r_{\max} or $r_{1 \max}$ in the axial direction of bearings with nominal width lower than 2 mm shall be the same as the value in radial direction.
- There shall be no specification for the accuracy of the shape of the chamfer surface, but its outline in the axial plane shall not be situated outside of the imaginary circle arc with a radius of r_{\min} or $r_{1 \min}$ which contacts the inner ring side face and bore, or the outer ring side face and outside surface.

(2) Radial bearings with locating snap ring (snap ring groove side) and cylindrical roller bearings (separate thrust collar and loose rib side)

Unit : mm

$r_{1 \min}$	Nominal bore dia. or nominal outside dia. d or D		$r_{1 \max}$	
	over	up to	Radial direction	Axial direction
0.2	–	–	0.5	0.5
0.3	–	40	0.6	0.8
	40	–	0.8	0.8
0.5	–	40	1	1.5
	40	–	1.3	1.5
0.6	–	40	1	1.5
	40	–	1.3	1.5
1	–	50	1.5	2.2
	50	–	1.9	2.2
1.1	–	120	2	2.7
	120	–	2.5	2.7
1.5	–	120	2.3	3.5
	120	–	3	3.5
2	–	80	3	4
	80	220	3.5	4
	220	–	3.8	4
2.1	–	280	4	4.5
	280	–	4.5	4.5
2.5	–	100	3.8	5
	100	280	4.5	5
3	–	280	5	5.5
	280	–	5.5	5.5
4	–	–	6.5	6.5
5	–	–	8	8
6	–	–	10	10

[Remark] There shall be no specification for the accuracy of the shape of the chamfer surface, but its outline in the axial plane shall not be situated outside of the imaginary circle arc with a radius of $r_{1 \min}$ which contacts the inner ring side face and bore, or the outer ring side face and outside surface.

(3) Cylindrical roller bearings (non-rib side) and angular contact ball bearings (front face side)

Unit : mm

$r_{1 \min}$	Nominal bore dia. or nominal outside dia. d or D		$r_{1 \max}$	
	over	up to	Radial direction	Axial direction
0.1	–	–	0.2	0.4
0.15	–	–	0.3	0.6
0.2	–	–	0.5	0.8
0.3	–	40	0.6	1
	40	–	0.8	1
0.6	–	40	1	2
	40	–	1.3	2
1	–	50	1.5	3
	50	–	1.9	3
1.1	–	120	2	3.5
	120	–	2.5	4
1.5	–	120	2.3	4
	120	–	3	5
2	–	80	3	4.5
	80	220	3.5	5
	220	–	3.8	6

[Remark] There shall be no specification for the accuracy of the shape of the chamfer surface, but its outline in the axial plane shall not be situated outside of the imaginary circle arc with a radius of $r_{1 \min}$ which contacts the inner ring side face and bore, or the outer ring side face and outside surface.

(4) Metric series tapered roller bearing

Unit : mm

r_{\min} or $r_{1\min}$	Nominal bore dia. or nominal outside dia. ¹⁾ d or D , mm		r_{\max} or $r_{1\max}$	
	over	up to	Radial direction	Axial direction
0.3	–	40	0.7	1.4
	40	–	0.9	1.6
0.6	–	40	1.1	1.7
	40	–	1.3	2
1	–	50	1.6	2.5
	50	–	1.9	3
1.5	–	120	2.3	3
	120	250	2.8	3.5
	250	–	3.5	4
2	–	120	2.8	4
	120	250	3.5	4.5
	250	–	4	5
2.5	–	120	3.5	5
	120	250	4	5.5
	250	–	4.5	6
3	–	120	4	5.5
	120	250	4.5	6.5
	250	400	5	7
	400	–	5.5	7.5
4	–	120	5	7
	120	250	5.5	7.5
	250	400	6	8
	400	–	6.5	8.5
5	–	180	6.5	8
	180	–	7.5	9
6	–	180	7.5	10
	180	–	9	11
7.5	–	–	<i>12.5</i>	<i>17</i>
9.5	–	–	<i>15</i>	<i>19</i>

[Note] 1) Inner ring shall be included in division d , and outer ring, in division D .

[Remarks]

1. There shall be no specification for the accuracy of the shape of the chamfer surface, but its outline in the axial plane shall not be situated outside of the imaginary circle arc with a radius of r_{\min} or $r_{1\min}$ which contacts the inner ring back face and bore, or the outer ring back face and outside surface.

2. Values in Italics are provided in JTEKT standards.

(5) Thrust bearing

Unit : mm

r_{\min} or $r_{1\min}$	r_{\max} or $r_{1\max}$
	Radial and axial direction
0.05	0.1
0.08	0.16
0.1	0.2
0.15	0.3
0.2	0.5
0.3	0.8
0.6	1.5
1	2.2
1.1	2.7
1.5	3.5
2	4
2.1	4.5
3	5.5
4	6.5
5	8
6	10
7.5	12.5
9.5	15
12	18
15	21
19	25

[Remark] There shall be no specification for the accuracy of the shape of the chamfer surface, but its outline in the axial plane shall not be situated outside of the imaginary circle arc with a radius of r_{\min} or $r_{1\min}$ which contacts with the shaft or central race back face and bore, or the housing race back face and outside surface.

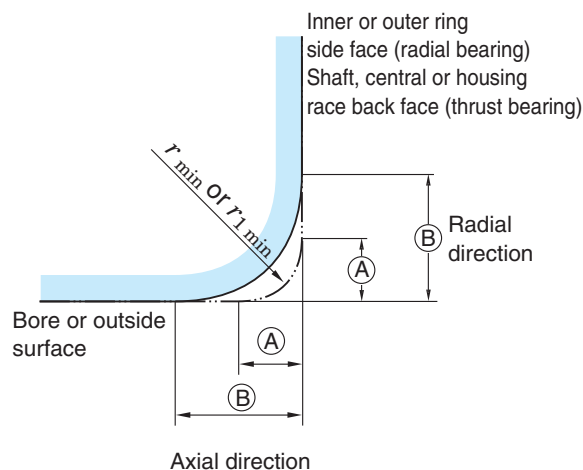

(A) : r_{\min} or $r_{1\min}$
(B) : r_{\max} or $r_{1\max}$

7-2 Tolerance measuring method (reference)

The details on measuring methods for bearings are prescribed in JIS B 1515.

This section outlines measuring methods for dimensional and running accuracy.

Dimensional accuracy (1)

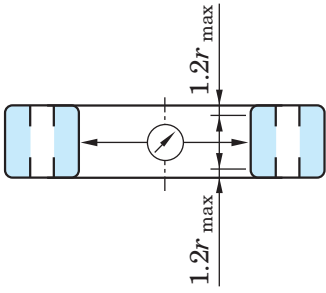
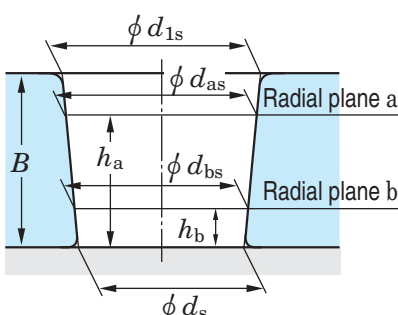
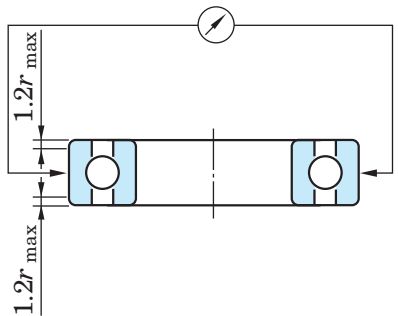
<p>Bore diameter (d) Cylindrical bore bearings</p>	<p>Obtain the maximum value ($d_{sp\ max}$) and the minimum value ($d_{sp\ min}$) of the bore diameter (d_s) acquired in a single radial plane. Obtain the single plane mean bore diameter (d_{mp}) as the arithmetic mean value of the maximum value ($d_{sp\ max}$) and minimum values ($d_{sp\ min}$).</p>  $d_{mp} = \frac{d_{sp\ max} + d_{sp\ min}}{2}$ <p>Single plane mean bore diameter deviation ; $\Delta d_{mp} = d_{mp} - d$ Bore diameter variation in a single plane ; $V_{d_{sp}} = d_{sp\ max} - d_{sp\ min}$ Mean bore diameter variation ; $V_{d_{mp}} = d_{mp\ max} - d_{mp\ min}$ Deviation of a single bore diameter ; $\Delta d_s = d_s - d$</p>
<p>Bore diameter (d) Tapered bore bearings</p>	<p>Bore diameter at the theoretical small end and bore diameter at the theoretical large end ;</p>  $d_s = \frac{d_{bs} \cdot h_a - d_{as} \cdot h_b}{h_a - h_b}$ $d_{1s} = \frac{d_{as} (B - h_b) - d_{bs} (B - h_a)}{h_a - h_b}$ <p>Single plane mean bore diameter deviation at the theoretical small end ; $\Delta d_{mp} = d_{mp} - d$ Deviation on taper ; $(\Delta d_{1mp} - \Delta d_{mp}) = (d_{1mp} - d_1) - (d_{mp} - d)$ Bore diameter variation in a single plane ; $V_{d_{sp}} = d_{sp\ max} - d_{sp\ min}$</p>
<p>Outside diameter (D)</p>	<p>Obtain the single plane mean outside diameter (D_{mp}) as the arithmetical mean value of the maximum value ($D_{sp\ max}$) and the minimum value ($D_{sp\ min}$) of the outside diameters (D_s) acquired in a single radial plane.</p>  $D_{mp} = \frac{D_{sp\ max} + D_{sp\ min}}{2}$ <p>Single plane mean outside diameter deviation ; $\Delta D_{mp} = D_{mp} - D$ Outside diameter variation in a single plane ; $V_{D_{sp}} = D_{sp\ max} - D_{sp\ min}$ Mean outside diameter variation ; $V_{D_{mp}} = D_{mp\ max} - D_{mp\ min}$ Deviation of a single outside diameter ; $\Delta D_s = D_s - D$</p>

Dimensional accuracy (2)

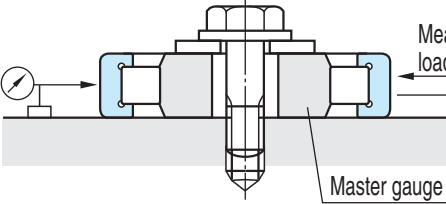
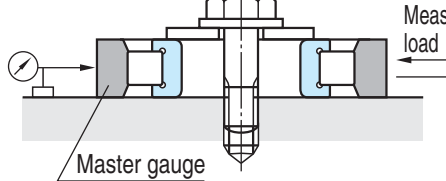
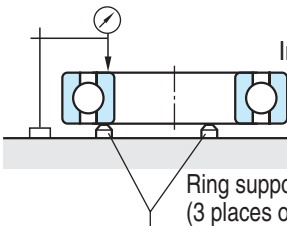
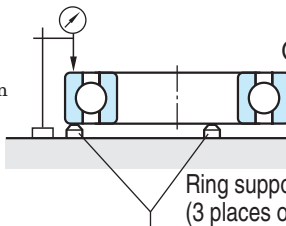
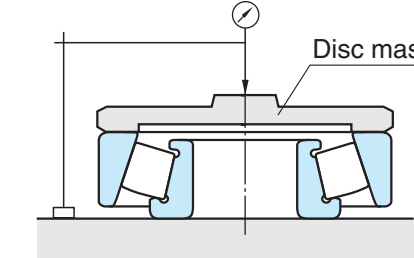
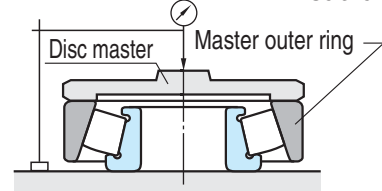
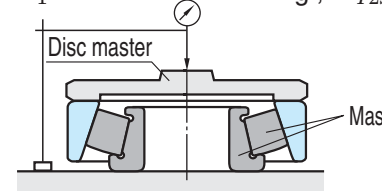
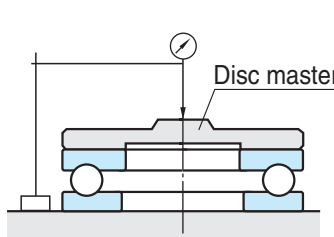
<p>Roller set bore diameter (F_w)</p>		<p>Deviation of the roller set bore diameter ; $\Delta F_w = (d_G + \delta_{1m}) - F_w$ Deviation of the minimum diameter of the roller set bore diameter ; $\Delta F_{w \min} = (d_G + \delta_{1\min}) - F_w$</p> <p>($d_G$) outside diameter of the master gauge (δ_{1m}) arithmetical mean value of the amount of movement of the outer ring ($\delta_{1\min}$) minimum value of the amount of movement of the outer ring</p>
<p>Roller set outside diameter (E_w)</p>		<p>Deviation of the roller set outside diameter ; $\Delta E_w = (D_G + \delta_{2m}) - E_w$</p> <p>($D_G$) bore diameter of the master gauge (δ_{2m}) arithmetical mean value of the amount of movement of the master gauge</p>
<p>Inner ring width (B)</p> <p>Outer ring width (C)</p>	<p>Deviation of a single inner ring width ; $\Delta B_s = B_s - B$ Inner ring width variation ; $V_{B_s} = B_{s \max} - B_{s \min}$</p>  <p>Ring supports (3 places on circumference)</p>	<p>Deviation of a single outer ring width ; $\Delta C_s = C_s - C$ Outer ring width variation ; $V_{C_s} = C_{s \max} - C_{s \min}$</p>  <p>Ring supports (3 places on circumference)</p>
<p>Assembled bearing width of tapered roller bearing (T)</p>		<p>Deviation of the actual bearing width ; $\Delta T_s = T_s - T$</p>
<p>Nominal effective width of tapered roller bearing (T_1, T_2)</p>	<p>Deviation of the actual effective width of inner sub-unit ; $\Delta T_{1s} = T_{1s} - T_1$</p> 	<p>Deviation of the actual effective width of outer ring ; $\Delta T_{2s} = T_{2s} - T_2$</p> 
<p>Nominal height of thrust ball bearing with flat back face (T, T_1)</p>		<p>Deviation of the actual bearing height ; $\Delta T_s = T_s - T$ (single direction) $\Delta T_{1s} = T_{1s} - T_1$ (double direction)</p>

Running accuracy (1)

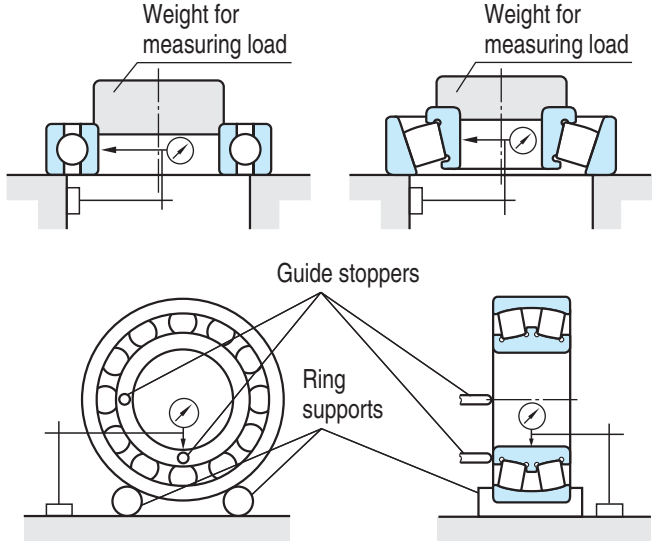
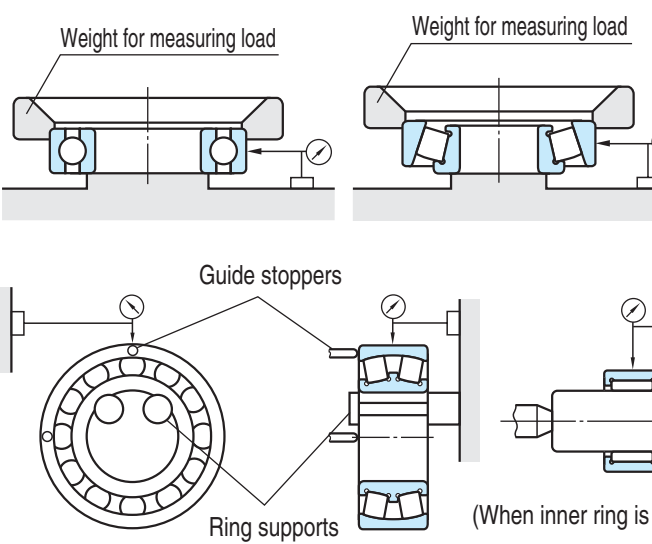
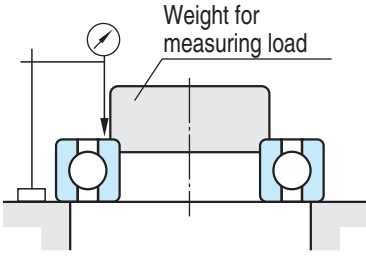
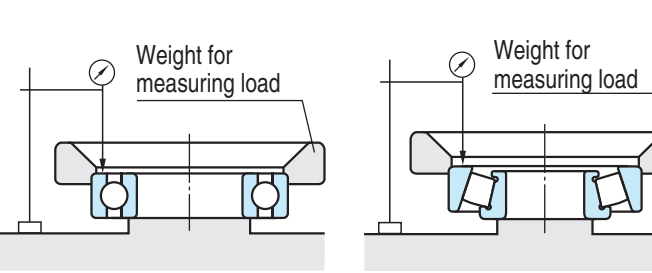
<p>Radial runout of assembled bearing inner ring (K_{ia})</p>		<p>The radial runout of the inner ring (K_{ia}) shall be obtained as the difference between the maximum value and the minimum value of the readings of the measuring instrument, when the inner ring has been rotated through one rotation.</p> <p>[Note] The measurement of the radial runout of the inner ring of cylindrical roller bearings, machined ring needle roller bearings, self-aligning ball bearings and spherical roller bearings shall be carried out by fixing the outer ring with ring supports.</p>
<p>Radial runout of assembled bearing outer ring (K_{ea})</p>		<p>The measurement of outer ring runout (K_{ea}) shall be obtained as the difference between the maximum value and the minimum value of the readings of the measuring instrument, when the outer ring has been rotated through one rotation.</p> <p>[Note] The measurement of the radial runout of the outer ring of cylindrical roller bearings, machined ring needle roller bearings, self-aligning ball bearings and spherical roller bearings shall be carried out by fixing the inner ring with ring supports.</p>
<p>Axial runout of assembled bearing inner ring (S_{ia})</p>		<p>The axial runout of the inner ring (S_{ia}) shall be obtained as the difference between the maximum value and the minimum value of the readings of the measuring instrument, when the inner ring has been rotated through one rotation.</p>
<p>Axial runout of assembled bearing outer ring (S_{ea})</p>		<p>The axial runout of the outer ring (S_{ea}) shall be obtained as the difference between the maximum value and the minimum value of the readings of the measuring instrument, when the outer ring has been rotated through one rotation.</p>

Running accuracy (2)

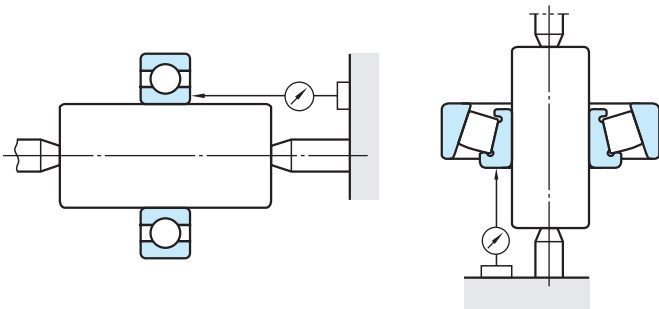
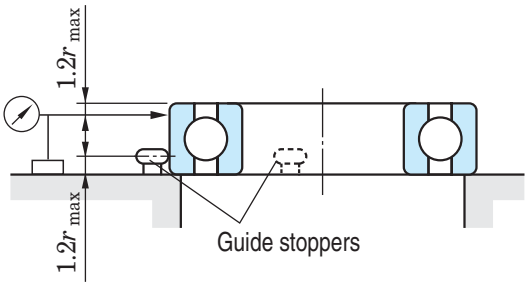
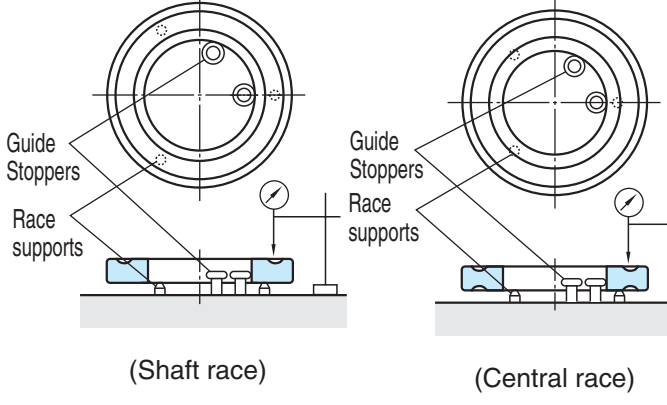
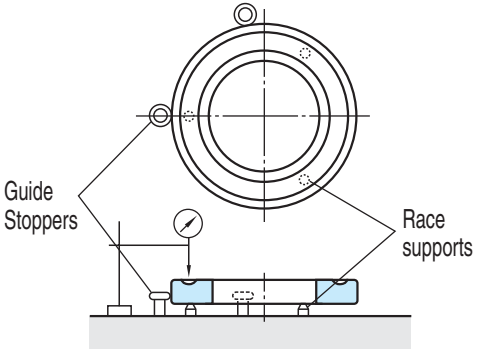
<p>Perpendicularity of inner ring face with respect to the bore (S_d)</p>		<p>Perpendicularity of inner ring face (S_d) shall be obtained as the difference between the maximum value and the minimum value of the readings of the measuring instrument, when the inner ring has been rotated through one rotation with the tapered arbor.</p>
<p>Perpendicularity of outer ring outside surface with respect to the face (S_D)</p>		<p>Perpendicularity of outer ring outside surface (S_D) shall be obtained as the difference between the maximum value and the minimum value of the readings of the measuring instrument, when the outer ring has been rotated through one rotation along the guide stopper.</p>
<p>Shaft/central race raceway to back face thickness variation of thrust ball bearing with flat back face (S_i)</p>		<p>The measurement of the thickness variation (S_i) of shaft race raceway track shall be obtained as the difference between the maximum value and the minimum value of the readings of the measuring instrument, when the shaft race has been rotated through one rotation along the guide stopper. For the central race, carry out the same measurement for the two raceway grooves to obtain the thickness variation of the raceway track (S_i).</p>
<p>Housing race raceway to back face thickness variation of thrust ball bearing with flat back face (S_e)</p>		<p>The measurement of the thickness variation (S_e) of housing race raceway track shall be obtained as the difference between the maximum value and the minimum value of the readings of the measuring instrument, when the housing race has been rotated through one rotation along the guide stopper.</p>

8. Limiting speed

The rotational speed of a bearing is normally affected by friction heat generated in the bearing. If the heat exceeds a certain amount, seizure or other failures occur, thus causing rotation to be discontinued.

The limiting speed is the highest speed at which a bearing can continuously operate without generating such critical heat.

The limiting speed differs depending on various factors including bearing type, dimensions and their accuracy, lubrication, lubricant type and amount, shapes of cages and materials and load conditions, etc.

The limiting speed determined under grease lubrication and oil lubrication (oil bath) for each bearing type are listed in the bearing specification table.

These speeds are applied when bearings of standard design are rotated under normal load conditions (approximately, $C/P \geq 13$, $F_a/F_r \leq 0.25$).

Each lubricant has superior performance in use, according to type.

Some are not suitable for high speed ; when bearing rotational speed exceeds 80 % of catalog specification, consult with JTEKT.

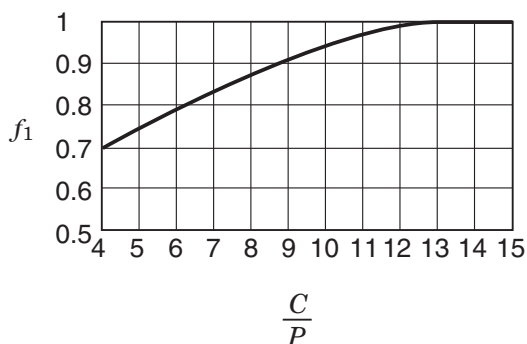

Fig. 8-1 Values of correction coefficient f_1 of load magnitude

8-1 Correction of limiting speed

When the load condition is $C/P < 13$, i.e. the dynamic equivalent load P exceeds approximately 8 % of basic dynamic load rating C , or when a combined load in which the axial load is greater than 25 % of radial load is applied, the limiting speed should be corrected by using equation (8-1) :

$$n_a = f_1 \cdot f_2 \cdot n \quad \text{..... (8-1)}$$

where :

- n_a : corrected limiting speed min^{-1}
- f_1 : correction coefficient determined from the load magnitude (Fig. 8-1)
- f_2 : correction coefficient determined from combined load (Fig. 8-2)
- n : limiting speed under normal load condition min^{-1}
(values in the bearing specification table)
- C : basic dynamic load rating N
- P : dynamic equivalent load N
- F_r : radial load N
- F_a : axial load N

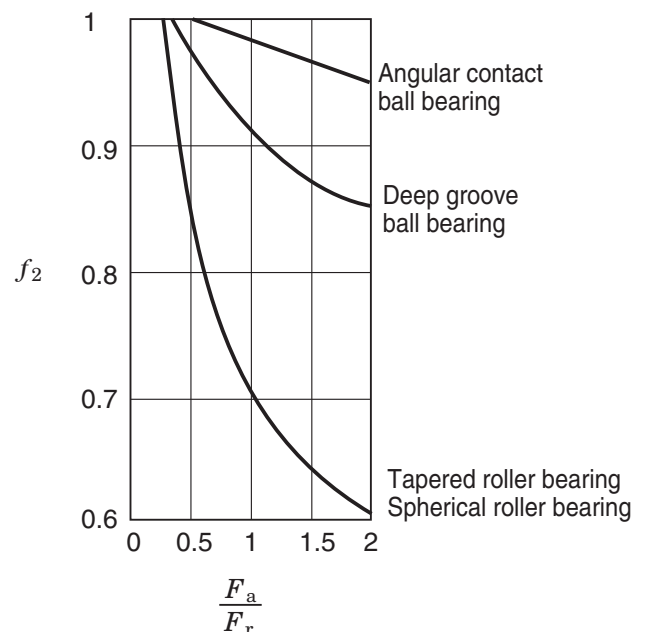

Fig. 8-2 Values of correction coefficient f_2 of combined load

8-2 Limiting speed for sealed ball bearings

The limiting speed of ball bearings with a contact seal (RS, RK type) are determined by the rubbing speed at which the seal contacts the inner ring. These allowable rubbing speeds differ depending on seal rubber materials; and, for ball bearings with the Koyo standard contact type seal (NBR), a rubbing speed of 15 m/s is utilized.

8-3 Considerations for high speed

When bearings are used for high speed, especially when the rotation speed approaches the limiting speed or exceeds it, the following should be considered :
(for further information on high speed, consult with JTEKT)

- (1) Use of high precision bearings
- (2) Study of proper internal clearance
{ Reduction in internal clearance caused by temperature increase should be considered. }
- (3) Selection of proper cage type and materials
{ For high speed, copper alloy or phenolic resin machined cages are suitable. Synthetic resin molded cages for high speed are also available. }
- (4) Selection of proper lubrication
{ Suitable lubrication for high speed should be selected jet lubrication, oil mist lubrication and oil air lubrication, etc. }

8-4 Frictional coefficient (reference)

The frictional moment of rolling bearings can be easily compared with that of plain bearings. The frictional moment of rolling bearings can be obtained from their bore diameter, using the following equation :

$$M = \mu P \frac{d}{2} \dots\dots\dots (8-2)$$

where :

- M : frictional moment mN · m
- μ : frictional coefficient
- P : load on the bearing N
- d : nominal bore diameter mm

The friction coefficient is greatly dependent on bearing type, bearing load, rotation speed and lubrication, etc.

Reference values for the friction coefficient during stable operation under normal operating conditions are listed in Table 8-1.

For plain bearings, the value is normally 0.01 to 0.02 ; but, for certain cases, it is 0.1 to 0.2.

Table 8-1 Friction coefficient μ

Bearing type	Friction coefficient μ
Deep groove ball bearing	0.001 0 – 0.001 5
Angular contact ball bearing	0.001 2 – 0.002 0
Self-aligning ball bearing	0.000 8 – 0.001 2
Cylindrical roller bearing	
Full complement type needle roller bearing	0.002 5 – 0.003 5
Needle roller and cage assembly	0.002 0 – 0.003 0
Tapered roller bearing	0.001 7 – 0.002 5
Spherical roller bearing	0.002 0 – 0.002 5
Thrust ball bearing	0.001 0 – 0.001 5
Spherical thrust roller bearing	0.002 0 – 0.002 5

9. Bearing fits

9-1 Purpose of fit

The purpose of fit is to securely fix the inner or outer ring to the shaft or housing, to preclude detrimental circumferential sliding on the fitting surface.

Such detrimental sliding (referred to as "creep") will cause abnormal heat generation, wear of the fitting surface, infiltration of abrasion metal particles into the bearing, vibration, and many other harmful effects, which cause a deterioration of bearing functions.

Therefore, it is necessary to fix the bearing ring which is rotating under load to the shaft or housing with interference.

9-2 Tolerance and fit for shaft & housing

For metric series bearings, tolerances for the shaft diameter and housing bore diameter are standardized in JIS B 0401-1 and 0401-2 "ISO system of limits and fits - Part 1 and Part 2" (based on ISO 286; shown in Appendixes at the back of this catalogue). Bearing fits on the shaft and housing are determined based on the tolerances specified in the above standard.

Fig. 9-1 shows the relationship between tolerances for shaft and housing bore diameters and fits for bearings of class 0 tolerance.

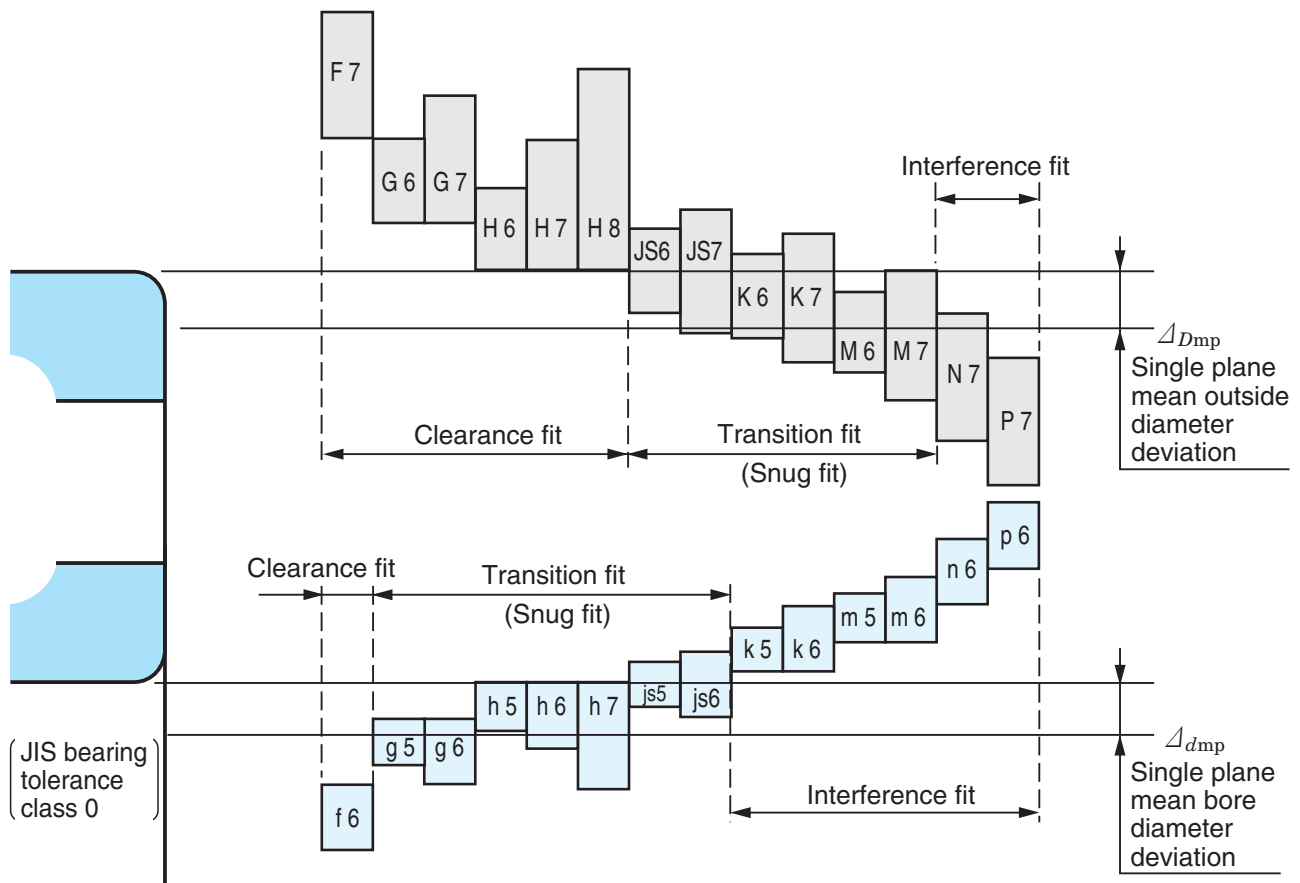

Fig. 9-1 Relationship between tolerances for shaft/housing bore diameters and fits (bearings of class 0 tolerance)

9-3 Fit selection

In selecting the proper fit, careful consideration should be given to bearing operating conditions.

Major specific considerations are :

- Load characteristics and magnitude
- Temperature distribution in operating
- Bearing internal clearance
- Surface finish, material and thickness of shaft and housing
- Mounting and dismounting methods
- Necessity to compensate for shaft thermal expansion at the fitting surface
- Bearing type and size



In view of these considerations, the following paragraphs explain the details of the important factors in fit selection.

1) Load characteristics

Load characteristics are classified into three types : rotating inner ring load; rotating outer ring load and indeterminate direction load.

Table 9-1 tabulates the relationship between these characteristics and fit.

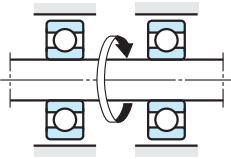
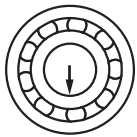
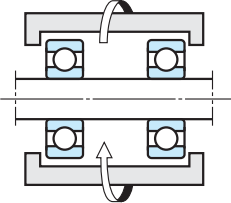
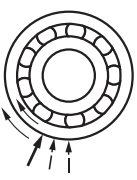
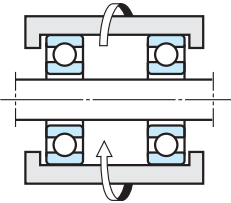
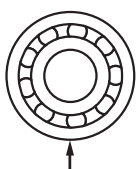
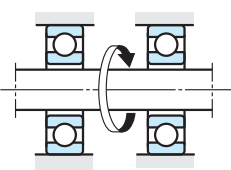
Table 9-1 Load characteristics and fits

Rotation pattern	Direction of load	Loading conditions	Fit		Typical application
			Inner ring & shaft	Outer ring & housing	
 <p>Inner ring : rotating Outer ring : stationary</p>	 <p>Stationary</p>	Rotating inner ring load	Interference fit necessary	Clearance fit acceptable	Spur gear boxes, motors
 <p>Inner ring : stationary Outer ring : rotating</p>	 <p>Rotating (with outer ring)</p>	Stationary outer ring load	(k, m, n, p, r)	(F, G, H, JS)	Greatly unbalanced wheels
 <p>Inner ring : stationary Outer ring : rotating</p>	 <p>Stationary</p>	Stationary inner ring load	Clearance fit acceptable	Interference fit necessary	Running wheels & pulleys with stationary shaft
 <p>Inner ring : rotating Outer ring : stationary</p>	 <p>Rotating (with inner ring)</p>	Rotating outer ring load	(f, g, h, js)	(K, M, N, P)	Shaker screens (unbalanced vibration)
Indeterminate	Rotating or stationary	Indeterminate direction load	Interference fit	Interference fit	Cranks

2) Effect of load magnitude

When a radial load is applied, the inner ring will expand slightly. Since this expansion enlarges the circumference of the bore minutely, the initial interference is reduced.

The reduction can be calculated by the following equations :

[In the case of $F_r \leq 0.25 C_0$]

$$\Delta_{dF} = 0.08 \sqrt{\frac{d}{B} \cdot F_r} \times 10^{-3} \dots\dots\dots (9-1)$$

[In the case of $F_r > 0.25 C_0$]

$$\Delta_{dF} = 0.02 \frac{F_r}{B} \times 10^{-3} \dots\dots\dots (9-2)$$

where:

- Δ_{dF} : reduction of inner ring interference mm
- d : nominal bore diameter of bearing mm
- B : nominal inner ring width mm
- F_r : radial load N
- C_0 : basic static load rating N

Consequently, when the radial load, exceeds the C_0 value by more than 25 %, greater interference is needed.

Much greater interference is needed, when impact loads are expected.

3) Effect of fitting surface roughness

The effective interference obtained after fitting differs from calculated interference due to plastic deformation of the ring fitting surface. When the inner ring is fitted, the effective interference, subject to the effect of the fitting surface finish, can be approximated by the following equations :

[In the case of a ground shaft]

$$\Delta_{deff} \doteq \frac{d}{d+2} \Delta_d \dots\dots\dots (9-3)$$

[In the case of a turned shaft]

$$\Delta_{deff} \doteq \frac{d}{d+3} \Delta_d \dots\dots\dots (9-4)$$

where:

- Δ_{deff} : effective interference mm
- Δ_d : calculated interference mm
- d : nominal bore diameter of bearing mm

4) Effect of temperature

A bearing generally has an operating temperature, higher than the ambient temperature. When the inner ring operates under load, its temperature generally becomes higher than that of the shaft and the effective interference decreases due to the greater thermal expansion of the inner ring.

If the assumed temperature difference between the bearing inside and surrounding housing is Δ_t , the temperature difference at the fitting surfaces of the inner ring and shaft will be approximately $(0.10 \text{ to } 0.15) \times \Delta_t$.

The reduction of interference (Δ_{dt}) due to temperature difference is then expressed as follows :

$$\Delta_{dt} = (0.10 \text{ to } 0.15) \Delta_t \cdot \alpha \cdot d$$

$$\doteq 0.0015 \Delta_t \cdot d \times 10^{-3} \dots\dots\dots (9-5)$$

where:

- Δ_{dt} : reduction of interference due to temperature difference mm
- Δ_t : temperature difference between the inside of the bearing and the surrounding housing °C
- α : linear expansion coefficient of bearing steel ($\doteq 12.5 \times 10^{-6}$) 1/°C
- d : nominal bore diameter of bearing mm

Consequently, when a bearing is higher in temperature than the shaft, greater interference is required.

However, a difference in temperature or in the coefficient of expansion may sometimes increase the interference between outer ring and housing. Therefore, when clearance is provided to accommodate shaft thermal expansion, care should be taken.

5) Maximum stress due to fit

When a bearing is fitted with interference, the bearing ring will expand or contract, generating internal stress.

Should this stress be excessive, the bearing ring may fracture.

The maximum bearing fitting-generated stress is determined by the equation in Table 9-2.

In general, to avoid fracture, it is best to adjust the maximum interference to less than 1/1 000 of the shaft diameter, or the maximum stress (σ), determined by the equation in Table 9-2, should be less than 120 MPa.

6) Other considerations

When a high degree of accuracy is required, the tolerance of the shaft and housing must be improved. Since the housing is generally less easy to machine precisely than the shaft, it is advisable to use a clearance fit on the outer ring.

With hollow shafts or thin section housings, greater than normal interference is needed.

With split housings, on the other hand, smaller interference with outer ring is needed.

When the housing is made of aluminum or other light metal alloy, relatively greater than normal interference is needed.

In such a case, consult with JTEKT.

Table 9-2 Maximum fitting-generated stress in bearings

Shaft & inner ring	Housing bore & outer ring
(In the case of hollow shaft)	(In the case of $D_h \neq \infty$)
$\sigma = \frac{E}{2} \cdot \frac{\Delta_{deff}}{d} \cdot \frac{\left(1 - \frac{d_0^2}{d^2}\right) \left(1 + \frac{d^2}{D_i^2}\right)}{\left(1 - \frac{d_0^2}{D_i^2}\right)}$	$\sigma = E \cdot \frac{\Delta_{Deff}}{D} \cdot \frac{\left(1 - \frac{D^2}{D_h^2}\right)}{\left(1 - \frac{D_e^2}{D_h^2}\right)}$
(In the case of solid shaft)	(In the case of $D_h = \infty$)
$\sigma = \frac{E}{2} \cdot \frac{\Delta_{deff}}{d} \cdot \left(1 + \frac{d^2}{D_i^2}\right)$	$\sigma = E \cdot \frac{\Delta_{Deff}}{D}$

where :

σ : maximum stress	MPa	D_e : raceway contact diameter of outer ring	mm
d : nominal bore diameter (shaft diameter)	mm	$\left\{ \begin{array}{l} \text{ball bearing} \dots\dots D_e \doteq 0.2 (4D + d) \\ \text{roller bearing} \dots D_e \doteq 0.25 (3D + d) \end{array} \right.$	
D_i : raceway contact diameter of inner ring	mm		D : nominal outside diameter (bore diameter of housing)
$\left\{ \begin{array}{l} \text{ball bearing} \dots\dots D_i \doteq 0.2 (D + 4 d) \\ \text{roller bearing} \dots D_i \doteq 0.25 (D + 3 d) \end{array} \right.$		Δ_{Deff} : effective interference of outer ring	mm
	Δ_{deff} : effective interference of inner ring	mm	D_h : outside diameter of housing
d_0 : bore diameter of hollow shaft	mm	E : young's modulus	2.08×10^5 MPa

[Remark] The above equations are applicable when the shaft and housing are steel. When other materials are used, JTEKT should be consulted.

9-4 Recommended fits

As described in Section 9-3, the characteristics / magnitude of the bearing load, temperature, mounting / dismounting methods and other conditions must be considered to choose proper fits.

Past experience is also valuable.

Table 9-3 shows standard fits for the metric series bearings; Tables 9-4 to 9-8 tabulate the most typical and recommended fits for different bearings types.

Table 9-3 Standard fits for metric series bearings¹⁾

(1) Fits for bore diameter²⁾ of radial bearings

Class of bearing	Rotating inner ring load or indeterminate direction load						Stationary inner ring load			
	Class of shaft tolerance range									
Classes 0, 6X, 6	r 6	p 6	n 6	m 6 m 5	k 6 k 5	js 6 js 5	h 5	h 6 h 5	g 6 g 5	f 6
Class 5	–	–	–	m 5	k 4	js 4	h 4	h 5	–	–
Fit	Interference fit					Transition fit				Clearance fit

(2) Fits for outside diameter²⁾ of radial bearings

Class of bearing	Stationary outer ring load				Indeterminate direction load or rotating outer ring load					
	Class of housing bore tolerance range									
Classes 0, 6X, 6	G 7	H 7 H 6	JS 7 JS 6	–	JS 7 JS 6	K 7 K 6	M 7 M 6	N 7 N 6	P 7	
Class 5	–	H 5	JS 5	K 5	–	K 5	M 5	–	–	
Fit	Clearance fit			Transition fit					Interference fit	

(3) Fits for bore diameter²⁾ of thrust bearings

Class of bearing	Central axial load (generally for thrust bearings)		Combined load (in the case of spherical thrust roller bearing)				
			Rotating shaft race load or indeterminate direction load			Stationary shaft race load	
	Class of shaft tolerance range						
Classes 0, 6	js 6	h 6	n 6	m 6	k 6		js 6
Fit	Transition fit		Interference fit			Transition fit	

(4) Fits for outside diameter²⁾ of thrust bearings

Class of bearing	Central axial load (generally for thrust bearings)		Combined load (in the case of spherical thrust roller bearing)				
			Stationary housing race load or indeterminate direction load			Rotating housing race load	
	Class of housing bore tolerance range						
Classes 0, 6	–	H 8	G 7	H 7	JS 7	K 7	M 7
Fit	Clearance fit				Transition fit		

[Notes] 1) Bearings specified in JIS B 1512
 2) Follow JIS B 1514-1 and 1514-2 for tolerance.

Table 9-4 (1) Recommended shaft fits for radial bearings (classes 0, 6X, 6)

Conditions ¹⁾	Ball bearing		Cylindrical roller bearing Tapered roller bearing		Spherical roller bearing		Class of shaft tolerance range	Remarks	Applications (for reference)	
	Shaft diameter (mm)									
	over	up to	over	up to	over	up to				
Cylindrical bore bearing (classes 0, 6X, 6)										
Rotating inner ring load or indeterminate direction load	Light load or fluctuating load $\left(\frac{P_r}{C_r} \leq 0.06\right)$	– 18 18 100 100 200 – –	– – – 40 40 140 140 200	– – – – – –	– – – – – –	– – – – – –	h 5 js 6 k 6 m 6	For applications requiring high accuracy, js 5, k 5 and m 5 should be used in place of js 6, k 6 and m 6.	Electric appliances, machine tools, pumps, blowers, carriers etc.	
	Normal load $\left(0.06 < \frac{P_r}{C_r} \leq 0.12\right)$	– 18 18 100 100 140 140 200 200 280 – – – –	– – – 40 40 100 100 140 140 200 200 400 – –	– – – 40 40 100 100 140 140 200 200 400 – –	– – – 40 40 65 65 100 100 140 140 280 280 500	– – – 40 40 65 65 100 100 140 140 280 280 500	js 5 k 5 m 5 m 6 n 6 p 6 r 6	For single-row tapered roller bearings and angular contact ball bearings, k 5 and m 5 may be replaced by k 6 and m 6, because internal clearance reduction due to fit need not be considered.	Electric motors, turbines, internal combustion engines, wood-working machines etc.	
	Heavy load or impact load $\left(\frac{P_r}{C_r} > 0.12\right)$	– – – – – –	– – 50 140 140 200 200 –	50 100 100 140 140 200	– – – – – –	– – – – – –	n 6 p 6 r 6	Bearings with larger internal clearance than standard are required.	Railway rolling stock axle journals, traction motors	
Stationary inner ring load	Inner ring needs to move smoothly on shaft.	All shaft diameters					g 6	For applications requiring high accuracy, g 5 should be used. For large size bearing, f 6 may be used for easier movement.	Stationary shaft wheels	
	Inner ring does not need to move smoothly on shaft.	All shaft diameters					h 6	For applications requiring high accuracy, h 5 should be used.	Tension pulleys, rope sheaves etc.	
Central axial load only	All shaft diameters					js 6	–	–		
Tapered bore bearing (class 0) (with adapter or withdrawal sleeve)										
All loads	All shaft diameters					h 9/IT 5 ²⁾	For transmission shafts, h 10/IT 7 ²⁾ may be applied.			

[Notes] 1) Light, normal, and heavy loads refer to those with dynamic equivalent radial loads (P_r) of 6 % or lower, over 6 % up to 12 % inclusive, and over 12 % respectively in relation to the basic dynamic radial load rating (C_r) of the bearing concerned.

2) IT 5 and IT 7 mean that shaft roundness tolerance, cylindricity tolerance, and other errors in terms of shape should be within the tolerance range of IT 5 and IT 7, respectively. For numerical values for standard tolerance grades IT 5 and IT 7, refer to supplementary table at end of this catalog.

[Remark] This table is applicable to solid steel shafts.

Table 9-4 (2) Recommended housing fits for radial bearings (classes 0, 6X, 6)

Conditions			Outer ring axial displacement ²⁾	Class of housing bore tolerance range	Remarks	Applications (for reference)
Housing	Load type etc. ¹⁾					
One-piece or split type	Stationary outer ring load	All load types	Easily displaceable	H 7	G 7 may be applied when a large size bearing is used, or if the temperature difference is large between the outer ring and housing.	Ordinary bearing devices, railway rolling stock axle boxes, power transmission equipment etc.
		Light or normal load		H 8	–	
		High temperature at shaft and inner ring		G 7	F 7 may be applied when a large size bearing is used, or if the temperature difference is large between the outer ring and housing.	Drying cylinders etc.
One-piece type	Indeterminate direction load	Light or normal load, requiring high running accuracy	Not displaceable in principle	K 6	Mainly applied to roller bearings.	
			Displaceable	JS 6	Mainly applied to ball bearings.	
		Requiring low-noise rotation	Easily displaceable	H 6	–	
	Indeterminate direction load	Light or normal load	Normally displaceable	JS 7	For applications requiring high accuracy, JS 6 and K 6 should be used in place of JS 7 and K 7.	Electric motors, pumps, crankshaft main bearings etc.
		Normal or heavy load	Not displaceable in principle	K 7		
		High impact load	Not displaceable	M 7		
	Rotating outer ring load	Light or fluctuating load	Not displaceable	M 7	–	Conveyor rollers, ropeways, tension pulleys etc.
		Normal or heavy load		N 7	Mainly applied to ball bearings.	Wheel hubs with ball bearings etc.
		Thin section housing, heavy or high impact load		P 7	Mainly applied to roller bearings.	Wheel hubs with roller bearings, bearings for large end of connecting rods etc.

[Notes] 1) Loads are classified as stated in Note 1) to Table 9-4 (1).

2) Indicating distinction between applications of non-separable bearings permitting and not permitting axial displacement of the outer rings.

[Remarks] 1. This table is applicable to cast iron or steel housings.

2. If only central axial load is applied to the bearing, select such tolerance range class as to provide clearance in the radial direction for outer ring.

Table 9-5 (1) Recommended shaft fits for precision extra-small/miniature ball bearings ($d < 10$ mm)

Unit : μm

Load type		Bearing tolerance class	Single plane mean bore diameter deviation Δ_{dmp}		Shaft diameter dimensional tolerance		Fit ¹⁾	Applications	
			upper	lower	upper	lower			
Rotating inner ring load	Middle/high speed Light or normal load	ABMA 5P	0	-5.1	+2.5	-2.5	7.6T - 2.5L	Gyro rotors, air cleaners, electric tools, encoders	
		JIS class 5	0	-5			7.5T - 2.5L		
	Low speed Light load	ABMA 7P	0	-5.1	+2.5	-2.5	7.6T - 2.5L		
		JIS class 4	0	-4			6.5T - 2.5L		
	Low speed Light load	ABMA 5P	0	-5.1	-2.5	-7.5	2.6T - 7.5L		Gyro gimbals, synchronizers, servomotors, floppy disc spindles
		JIS class 5	0	-5			2.5T - 7.5L		
Low speed Light load	ABMA 7P	0	-5.1	-2.5	-7.5	2.6T - 7.5L			
	JIS class 4	0	-4			1.5T - 7.5L			
Rotating outer ring load	Low to high speed Light load	ABMA 5P	0	-5.1	-2.5	-7.5	2.6T - 7.5L	Pinch rolls, tape guide rollers, linear actuators	
		JIS class 5	0	-5			2.5T - 7.5L		
	Low to high speed Light load	ABMA 7P	0	-5.1	-2.5	-7.5	2.6T - 7.5L		
		JIS class 4	0	-4			1.5T - 7.5L		

[Note] 1) Symbols T and L means interference and clearance respectively.

Table 9-5 (2) Recommended housing fits for precision extra-small/miniature ball bearings ($D \leq 30$ mm)

Unit : μm

Load type		Bearing tolerance class	Single plane mean outside diameter deviation Δ_{Dmp}		Housing bore diameter dimensional tolerance		Fit ¹⁾	Applications	
			upper	lower	upper	lower			
Rotating inner ring load	Middle/high speed Light or normal load	ABMA 5P	0	-5.1	+5	0	0 - 10.1L	Gyro rotors, air cleaners, electric tools, encoders	
		ABMA 7P							
		JIS class 5 ²⁾	0	-5	+5	0	0 - 10 L		
	Low speed Light load	JIS class 4 ²⁾		0	-4	+5	0		0 - 9 L
				0	-5				0 - 10 L
		ABMA 5P	0	-5.1	+2.5	-2.5	2.5T - 7.6L		
	Low speed Light load	JIS class 5 ²⁾		0	-5	+2.5	-2.5		2.5T - 7.5L
				0	-6				2.5T - 8.5L
		JIS class 4 ²⁾	0	-4	+2.5	-2.5	2.5T - 6.5L		
			0	-5			2.5T - 7.5L		
Rotating outer ring load	Low to high speed Light load	ABMA 5P	0	-5.1	+2.5	-2.5	2.5T - 7.6L	Pinch rolls, tape guide rollers	
		ABMA 7P							
	Low to high speed Light load	JIS class 5 ²⁾	0	-5	+2.5	-2.5	2.5T - 7.5L		
			0	-6			2.5T - 8.5L		
	Low to high speed Light load	JIS class 4 ²⁾	0	-4	+2.5	-2.5	2.5T - 6.5L		
			0	-5			2.5T - 7.5L		

[Notes] 1) Symbols T and L means interference and clearance respectively.

2) In the columns "single plane mean outside diameter deviation" and "fit" upper row values are applied in the case of $D \leq 18$ mm, lower row values in the case of $18 < D \leq 30$ mm.

Table 9-6 (1) Recommended shaft fits for metric J series tapered roller bearings

■ Bearing tolerance : class PK, class PN

Load type		Nominal bore diameter <i>d</i> mm		Class of shaft tolerance range	Remarks
		over	up to		
Rotating inner ring load	Normal load	10	120	m 6	Generally, bearing internal clearance should be larger than standard.
		120	500	n 6	
	Heavy load Impact load High speed rotation	10	120	n 6	
		120	180	p 6	
		180	250	r 6	
		250	500	r 7	
Rotating outer ring load	Normal load without impact	80	315	h 6 or g 6	Generally, bearing internal clearance should be larger than standard.
	Heavy load Impact load High speed rotation	10	120	n 6	
		120	180	p 6	
		180	250	r 6	
		250	500	r 7	

■ Bearing tolerance : class PC, class PB

Load type		Nominal bore diameter <i>d</i> mm		Class of shaft tolerance range		Remarks
				(bearing tolerance class)		
		over	up to	PC	PB	
Rotating inner ring load	Spindles of precision machine tools	10	315	k 5	k 5	Generally, bearing internal clearance should be larger than standard.
		315	500	k 5	–	
	Heavy load Impact load High speed rotation	10	18	m 6	m 5	
		18	50	m 5	m 5	
		50	80	n 5	n 5	
		80	120	n 5	n 4	
		120	180	p 4	p 4	
		180	250	r 4	r 4	
		250	315	r 5	r 4	
		315	500	r 5	–	
Rotating outer ring load	Spindles of precision machine tools	10	315	k 5	k 5	
		315	500	k 5	–	

Table 9-6 (2) Recommended housing fits for metric J series tapered roller bearings

■ Bearing tolerance : class PK, class PN

Load type		Nominal outside diameter D mm		Class of housing bore diameter tolerance range		Remarks
		over	up to			
Rotating inner ring load	Used for free or fixed side	18 315	315 400	G 7 F 6		Outer ring is easily displaceable in axial direction.
	Position of outer ring is adjustable (in axial direction)	18	400	J 7		Outer ring is displaceable in axial direction.
	Position of outer ring is not adjustable (in axial direction)	18	400	P 7		Outer ring is fixed in axial direction.
Rotating outer ring load	Position of outer ring is not adjustable (in axial direction)	18 120 180	120 180 400	R 7		Outer ring is fixed in axial direction.

■ Bearing tolerance : class PC, class PB

Load type		Nominal outside diameter D mm		Class of housing bore diameter tolerance range		Remarks
				(bearing tolerance class)		
		over	up to	PC	PB	
Rotating inner ring load	Used for free side	18	315	G 5	G 5	Outer ring is easily displaceable in axial direction.
		315	500	G 5	–	
	Used for fixed side	18	315	H 5	H 4	Outer ring is displaceable in axial direction.
		315	500	H 5	–	
		Position of outer ring is adjustable (in axial direction)	18	120	K 5	
120	180		JS 6	JS 6		
180	250		JS 6	JS 5		
250	315		K 5	JS 5		
Position of outer ring is not adjustable (in axial direction)	315	500	K 5	–		
	18	315	N 5	M 5		
Rotating outer ring load	Position of outer ring is not adjustable (in axial direction)	315	500	N 5	–	Outer ring is fixed in axial direction.
		250	315	N 5	N 5	
		18	250	N 6	N 5	

Table 9-7 (1) Recommended shaft fits for inch series tapered roller bearings

■ Bearing tolerance : class 4, class 2

Load type		Nominal bore diameter d mm (1/25.4)		Deviation of a single bore diameter $\Delta_{ds}, \mu\text{m}$		Dimensional tolerance of shaft diameter μm		Remarks
		over	up to	upper	lower	upper	lower	
Rotating inner ring load	Normal load	-	76.2 (3.0)	+13	0	+ 38	+ 25	Generally, bearing internal clearance should be larger than standard.
		76.2 (3.0)	304.8 (12.0)	+25	0	+ 64	+ 38	
		304.8 (12.0)	609.6 (24.0)	+51	0	+127	+ 76	
		609.6 (24.0)	914.4 (36.0)	+76	0	+190	+114	
	Heavy load	-	76.2 (3.0)	+13	0	Should be such that average interference stands at $0.0005 \times d$ (mm)		
	Impact load	76.2 (3.0)	304.8 (12.0)	+25	0			
High speed rotation	304.8 (12.0)	609.6 (24.0)	+51	0				
	609.6 (24.0)	914.4 (36.0)	+76	0				
Rotating outer ring load	Normal load without impact	-	76.2 (3.0)	+13	0	+ 13	0	Inner ring is displaceable in axial direction.
		76.2 (3.0)	304.8 (12.0)	+25	0	+ 25	0	
		304.8 (12.0)	609.6 (24.0)	+51	0	+ 51	0	
		609.6 (24.0)	914.4 (36.0)	+76	0	+ 76	0	
	Normal load without impact	-	76.2 (3.0)	+13	0	0	- 13	
		76.2 (3.0)	304.8 (12.0)	+25	0	0	- 25	
		304.8 (12.0)	609.6 (24.0)	+51	0	0	- 51	
	Heavy load	-	76.2 (3.0)	+13	0	Should be such that average interference stands at $0.0005 \times d$ (mm)		
		76.2 (3.0)	304.8 (12.0)	+25	0			
304.8 (12.0)		609.6 (24.0)	+51	0				
Impact load	76.2 (3.0)	304.8 (12.0)	+25	0	Should be such that average interference stands at $0.0005 \times d$ (mm)			
	304.8 (12.0)	609.6 (24.0)	+51	0				
	609.6 (24.0)	914.4 (36.0)	+76	0				

■ Bearing tolerance : class 3, class 0¹⁾

Load type		Nominal bore diameter d mm (1/25.4)		Deviation of a single bore diameter $\Delta_{ds}, \mu\text{m}$		Dimensional tolerance of shaft diameter μm		Remarks
		over	up to	upper	lower	upper	lower	
Rotating inner ring load	Spindles of precision machine tools	-	76.2 (3.0)	+13	0	+ 30	+ 18	Generally, bearing internal clearance should be larger than standard.
		76.2 (3.0)	304.8 (12.0)	+13	0	+ 30	+ 18	
		304.8 (12.0)	609.6 (24.0)	+25	0	+ 64	+ 38	
		609.6 (24.0)	914.4 (36.0)	+38	0	+102	+ 64	
	Heavy load	-	76.2 (3.0)	+13	0	Should be such that average interference stands at $0.0005 \times d$ (mm)		
		76.2 (3.0)	304.8 (12.0)	+13	0			
Impact load	76.2 (3.0)	304.8 (12.0)	+13	0	Should be such that average interference stands at $0.0005 \times d$ (mm)			
	304.8 (12.0)	609.6 (24.0)	+25	0				
High speed rotation	304.8 (12.0)	609.6 (24.0)	+25	0	Should be such that average interference stands at $0.0005 \times d$ (mm)			
	609.6 (24.0)	914.4 (36.0)	+38	0				
Rotating outer ring load	Spindles of precision machine tools	-	76.2 (3.0)	+13	0	+ 30	+ 18	
		76.2 (3.0)	304.8 (12.0)	+13	0	+ 30	+ 18	
		304.8 (12.0)	609.6 (24.0)	+25	0	+ 64	+ 38	
		609.6 (24.0)	914.4 (36.0)	+38	0	+102	+ 64	

[Note] 1) Class 0 bearing : $d \leq 304.8$ mm

Table 9-7 (2) Recommended housing fits for inch series tapered roller bearings

■ Bearing tolerance : class 4, class 2

Load type		Nominal outside diameter D mm (1/25.4)		Deviation of a single outside diameter $\Delta_{Ds}, \mu\text{m}$		Dimensional tolerance of housing bore diameter μm		Remarks
		over	up to	upper	lower	upper	lower	
Rotating inner ring load	Used for free or fixed side.	–	76.2 (3.0)	+ 25	0	+ 76	+ 51	Outer ring is easily displaceable in axial direction.
		76.2 (3.0)	127.0 (5.0)	+ 25	0	+ 76	+ 51	
		127.0 (5.0)	304.8 (12.0)	+ 25	0	+ 76	+ 51	
		304.8 (12.0)	609.6 (24.0)	+ 51	0	+152	+102	
		609.6 (24.0)	914.4 (36.0)	+ 76	0	+229	+152	
	Position of outer ring is adjustable (in axial direction).	–	76.2 (3.0)	+ 25	0	+ 25	0	Outer ring is displaceable in axial direction.
		76.2 (3.0)	127.0 (5.0)	+ 25	0	+ 25	0	
		127.0 (5.0)	304.8 (12.0)	+ 25	0	+ 51	0	
		304.8 (12.0)	609.6 (24.0)	+ 51	0	+ 76	+ 25	
Position of outer ring is not adjustable (in axial direction).	–	76.2 (3.0)	+ 25	0	– 13	– 38	Outer ring is fixed in axial direction.	
	76.2 (3.0)	127.0 (5.0)	+ 25	0	– 25	– 51		
	127.0 (5.0)	304.8 (12.0)	+ 25	0	– 25	– 51		
	304.8 (12.0)	609.6 (24.0)	+ 51	0	– 25	– 76		
Rotating outer ring load	Position of outer ring is not adjustable (in axial direction).	–	76.2 (3.0)	+ 25	0	– 13	– 38	Outer ring is fixed in axial direction.
		76.2 (3.0)	127.0 (5.0)	+ 25	0	– 25	– 51	
		127.0 (5.0)	304.8 (12.0)	+ 25	0	– 25	– 51	
		304.8 (12.0)	609.6 (24.0)	+ 51	0	– 25	– 76	
		609.6 (24.0)	914.4 (36.0)	+ 76	0	– 25	–102	

 ■ Bearing tolerance : class 3, class 0¹⁾

Load type		Nominal outside diameter D mm (1/25.4)		Deviation of a single outside diameter $\Delta_{Ds}, \mu\text{m}$		Dimensional tolerance of housing bore diameter μm		Remarks
		over	up to	upper	lower	upper	lower	
Rotating inner ring load	Used for free side.	–	152.4 (6.0)	+ 13	0	+ 38	+ 25	Outer ring is easily displaceable in axial direction.
		152.4 (6.0)	304.8 (12.0)	+ 13	0	+ 38	+ 25	
		304.8 (12.0)	609.6 (24.0)	+ 25	0	+ 64	+ 38	
		609.6 (24.0)	914.4 (36.0)	+ 38	0	+ 89	+ 51	
	Used for fixed side.	–	152.4 (6.0)	+ 13	0	+ 25	+ 13	Outer ring is displaceable in axial direction.
		152.4 (6.0)	304.8 (12.0)	+ 13	0	+ 25	+ 13	
		304.8 (12.0)	609.6 (24.0)	+ 25	0	+ 51	+ 25	
	Position of outer ring is adjustable (in axial direction).	–	152.4 (6.0)	+ 13	0	+ 13	0	Outer ring is fixed in axial direction.
		152.4 (6.0)	304.8 (12.0)	+ 13	0	+ 25	0	
304.8 (12.0)		609.6 (24.0)	+ 25	0	+ 25	0		
609.6 (24.0)		914.4 (36.0)	+ 38	0	+ 38	0		
Position of outer ring is not adjustable (in axial direction).	–	152.4 (6.0)	+ 13	0	0	– 13	Outer ring is fixed in axial direction.	
	152.4 (6.0)	304.8 (12.0)	+ 13	0	0	– 25		
	304.8 (12.0)	609.6 (24.0)	+ 25	0	0	– 25		
	609.6 (24.0)	914.4 (36.0)	+ 38	0	0	– 38		
Rotating outer ring load	Position of outer ring is not adjustable (in axial direction).	–	152.4 (6.0)	+ 13	0	– 13	– 25	Outer ring is fixed in axial direction.
		152.4 (6.0)	304.8 (12.0)	+ 13	0	– 13	– 38	
		304.8 (12.0)	609.6 (24.0)	+ 25	0	– 13	– 38	
		609.6 (24.0)	914.4 (36.0)	+ 38	0	– 13	– 51	

 [Note] 1) Class 0 bearing : $D \leq 304.8$ mm

Table 9-8 (1) Recommended shaft fits for thrust bearings (classes 0, 6)

Load type	Shaft diameter, mm		Class of shaft tolerance range	Remarks	
	over	up to			
Central axial load (generally for thrust bearings)	All shaft diameters		js 6	h 6 may also be used.	
Combined load (spherical thrust roller bearing)	Stationary shaft race load	All shaft diameters	js 6	–	
	Rotating shaft race load or indeterminate direction load	–	200	k 6	js 6, k 6 and m 6 may be used in place of k 6, m 6 and n 6, respectively.
		200	400	m 6	
400	–	n 6			

Table 9-8 (2) Recommended housing fits for thrust bearings (classes 0, 6)

Load type	Class of housing bore diameter tolerance range	Remarks	
Central axial load (generally for thrust bearings)	–	Select such tolerance range class as provides clearance in the radial direction for housing race.	
	H 8	In case of thrust ball bearings requiring high accuracy.	
Combined load (spherical thrust roller bearing)	Stationary housing race load	H 7	–
	Indeterminate direction load or rotating housing race load	K 7	In case of application under normal operating conditions.
		M 7	In case of comparably large radial load.

[Remark] This table is applicable to cast iron or steel housings.

10. Bearing internal clearance

Bearing internal clearance is defined as the total distance either inner or outer ring can be moved when the other ring is fixed.

If movement is in the radial direction, it is called radial internal clearance; if in the axial direction, axial internal clearance.

(Fig. 10-1)

Bearing performance depends greatly upon internal clearance during operation (also referred to as operating clearance); inappropriate clearance results in short rolling fatigue life and generation of heat, noise or vibration.

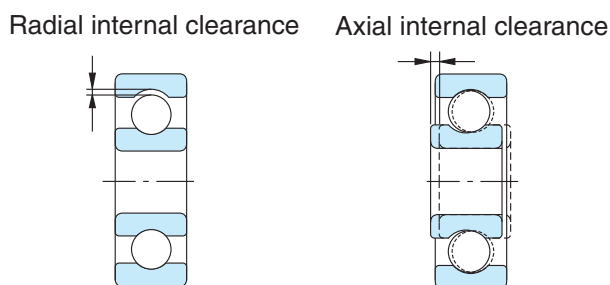

Fig. 10-1 Bearing internal clearance

In measuring internal clearance, a specified load is generally applied in order to obtain stable measurement values.

Consequently, measured clearance values will be larger than the original clearance by the amount of elastic deformation due to the load applied for measurement.

As far as roller bearings are concerned, however, the amount of elastic deformation is negligible.

Clearance prior to mounting is generally defined as the original clearance.

10-1 Selection of internal clearance

The term "residual clearance" is defined as the original clearance decreased owing to expansion or contraction of a raceway due to fitting, when the bearing is mounted in the shaft and housing.

The term "effective clearance" is defined as the residual clearance decreased owing to dimensional change arising from temperature differentials within the bearing.

The term "operating clearance" is defined as the internal clearance present while a bearing mounted in a machine is rotating under a certain load, or, the effective clearance increased due to elastic deformation arising from bearing loads.

As illustrated in Fig. 10-2, bearing fatigue life is longest when the operating clearance is slightly negative.

However, as the operating clearance becomes more negative, the fatigue life shortens remarkably.

Thus it is recommended that bearing internal clearance be selected such that the operating clearance is slightly positive.

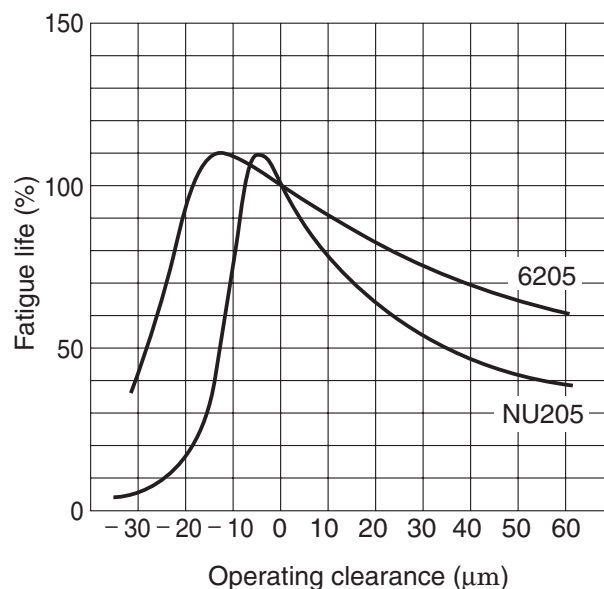

Fig. 10-2 Relationship between operating clearance and fatigue life

It is important to take specific operating conditions into consideration and select a clearance suitable for the conditions.

For example, when high rigidity is required, or when the noise must be minimized, the operating clearance must be reduced. On the other hand, when high operating temperature is expected, the operating clearance must be increased.

10-2 Operating clearance

Table 10-1 shows how to determine the operating clearance when the shaft and housing are made of steel.

Tables 10-2 to 10-10 show standard values for bearing internal clearance before mounting.

Table 10-11 shows examples of clearance selection excluding CN clearance.

Table 10-1 How to determine operating clearance

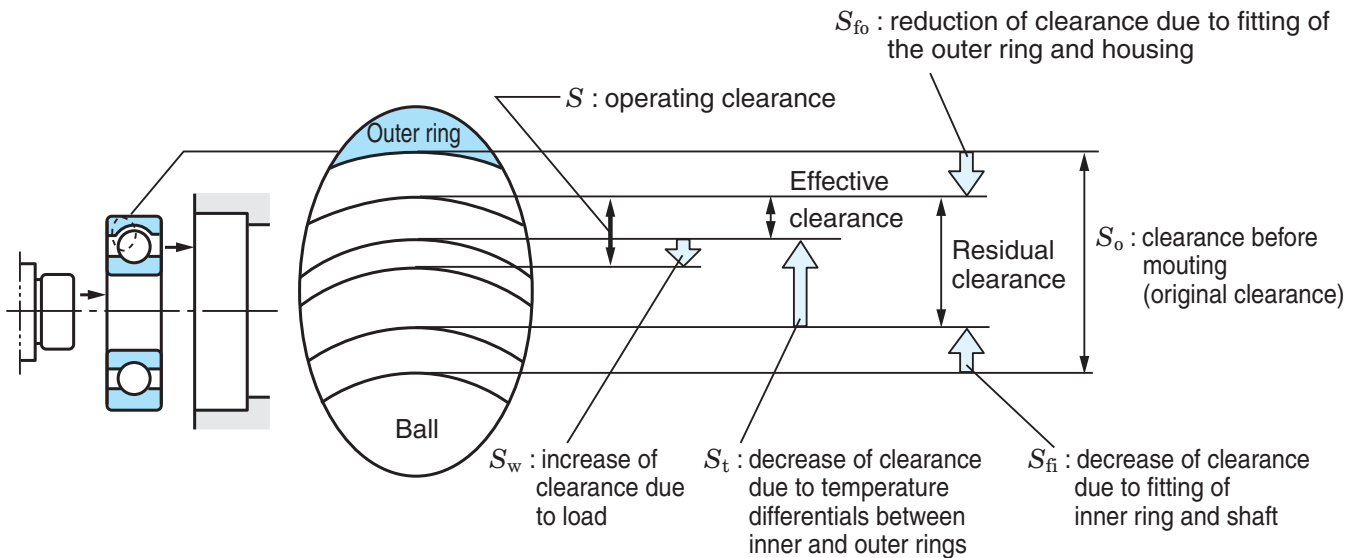

<p>Operating clearance (S)</p>	$S = S_o - (S_{fi} + S_{t1} + S_{t2}) + S_w^*$	<p>* S_w (increase of clearance due to load) is generally small, and thus may be ignored, although there is an equation for determining the value.</p>
<p>Decrease of clearance due to fitting (S_{fi})</p>	<p>(In the case of hollow shaft)</p> $S_{fi} = \Delta_{deff} \frac{d}{D_i} \cdot \frac{\left(1 - \frac{d_0^2}{d^2}\right)}{\left(1 - \frac{d_0^2}{D_i^2}\right)}$ <p>(In the case of solid shaft)</p> $S_{fi} = \Delta_{deff} \frac{d}{D_i}$	<p>(In the case of $D_h \neq \infty$)</p> $S_{fo} = \Delta_{deff} \frac{D_e}{D} \cdot \frac{\left(1 - \frac{D^2}{D_h^2}\right)}{\left(1 - \frac{D_e^2}{D_h^2}\right)}$ <p>(In the case of $D_h = \infty$)</p> $S_{fo} = \Delta_{deff} \frac{D_e}{D}$
<p>Decrease of clearance due to temperature differentials between inner and outer rings (S_{t1})</p>	<p>The amount of decrease varies depending on the state of housing; however, generally the amount can be approximated by the following equation on the assumption that the outer ring will not expand :</p> $S_{t1} = \alpha (D_i \cdot t_1 - D_e \cdot t_e)$	<p>where : $D_e = D_i + 2D_w$ Consequently, $S_{t1} + S_{t2}$ will be determined by the following equation :</p> $S_{t1} + S_{t2} = \alpha \cdot D_i \cdot t_1 + 2 \alpha \cdot D_w \cdot t_2$
<p>Decrease of clearance due to temperature rise of rolling element (S_{t2})</p>	$S_{t2} = 2 \alpha \cdot D_w \cdot t_w$	<p>Temperature differential between the inner and outer rings, t_1, can be expressed as follows :</p> $t_1 = t_i - t_e$ <p>Temperature differential between the rolling element and outer ring, t_2, can be expressed as follows :</p> $t_2 = t_w - t_e$

In Table 10-1,

S : operating clearance	mm	Δ_{Deff} : effective interference of outer ring	mm
S_o : clearance before mounting	mm	D_h : outside diameter of housing	mm
S_f : decrease of clearance due to fitting	mm	D_e : outer ring raceway contact diameter	mm
S_{fi} : expansion of inner ring raceway contact diameter	mm	$\left(\begin{array}{l} \text{ball bearing} \dots\dots D_e \doteq 0.2(4D + d) \\ \text{roller bearing} \dots\dots D_e \doteq 0.25(3D + d) \end{array} \right)$	
S_{fo} : contraction of outer ring raceway contact diameter	mm		D : nominal outside diameter
S_{t1} : decrease of clearance due to temperature differentials between inner and outer rings	mm	α : linear expansion coefficient of bearing steel (12.5×10^{-6})	1/°C
S_{t2} : decrease of clearance due to temperature rise of the rolling elements	mm	D_w : average diameter of rolling elements	mm
S_w : increase of clearance due to load	mm	$\left(\begin{array}{l} \text{ball bearing} \dots\dots D_w \doteq 0.3(D - d) \\ \text{roller bearing} \dots\dots D_w \doteq 0.25(D - d) \end{array} \right)$	
Δ_{deff} : effective interference of inner ring	mm		t_i : temperature rise of the inner ring
d : nominal bore diameter (shaft diameter)	mm	t_e : temperature rise of the outer ring	°C
d_0 : bore diameter of hollow shaft	mm	t_w : temperature rise of rolling elements	°C
D_i : inner ring raceway contact diameter	mm		
		$\left(\begin{array}{l} \text{ball bearing} \dots\dots D_i \doteq 0.2(D + 4d) \\ \text{roller bearing} \dots\dots D_i \doteq 0.25(D + 3d) \end{array} \right)$	

■ Bearings are sometimes used with a non-steel shaft or housing.

In the automotive industry, a statistical method is often incorporated for selection of clearance.

In these cases, or when other special operating conditions are involved, JTEKT should be consulted.

Table 10-2 Radial internal clearance of deep groove ball bearings (cylindrical bore)

Unit : μm

Nominal bore diameter d , mm		Clearance									
		C 2		C N		C 3		C 4		C 5	
over	up to	min.	max.	min.	max.	min.	max.	min.	max.	min.	max.
2.5	6	0	7	2	13	8	23	<i>14</i>	<i>29</i>	<i>20</i>	<i>37</i>
6	10	0	7	2	13	8	23	14	29	20	37
10	18	0	9	3	18	11	25	18	33	25	45
18	24	0	10	5	20	13	28	20	36	28	48
24	30	1	11	5	20	13	28	23	41	30	53
30	40	1	11	6	20	15	33	28	46	40	64
40	50	1	11	6	23	18	36	30	51	45	73
50	65	1	15	8	28	23	43	38	61	55	90
65	80	1	15	10	30	25	51	46	71	65	105
80	100	1	18	12	36	30	58	53	84	75	120
100	120	2	20	15	41	36	66	61	97	90	140
120	140	2	23	18	48	41	81	71	114	105	160
140	160	2	23	18	53	46	91	81	130	120	180
160	180	2	25	20	61	53	102	91	147	135	200
180	200	2	30	25	71	63	117	107	163	150	230
200	225	2	35	25	85	75	140	125	195	175	265
225	250	2	40	30	95	85	160	145	225	205	300
250	280	2	45	35	105	90	170	155	245	225	340
280	315	2	55	40	115	100	190	175	270	245	370
315	355	3	60	45	125	110	210	195	300	275	410
355	400	3	70	55	145	130	240	225	340	315	460

- [Remarks] 1. For measured clearance, the increase of radial internal clearance caused by the measurement load should be added to the values in the above table for correction. Amounts for correction are as shown below.
Of the amounts for clearance correction in the C 2 column, the smaller is applied to the minimum clearance, the larger to the maximum clearance.
2. Values in Italics are prescribed in JTEKT standards.

Nominal bore diameter d , mm		Measurement load	Amounts of clearance correction, μm				
			C 2	C N	C 3	C 4	C 5
over	up to	N					
2.5	18	24.5	3 – 4	4	4	4	4
18	50	49	4 – 5	5	6	6	6
50	280	147	6 – 8	8	9	9	9

Table 10-3 Radial internal clearance of extra-small/miniature ball bearings Unit : μm

Clearance code	M 1		M 2		M 3		M 4		M 5		M 6	
	min.	max.	min.	max.	min.	max.	min.	max.	min.	max.	min.	max.
Clearance	0	5	3	8	5	10	8	13	13	20	20	28

[Remark] For measured clearance, the following amounts should be added for correction.

Measurement load, N		Amounts of clearance correction, μm					
Extra-small ball bearing	Miniature ball bearing	M1	M2	M3	M4	M5	M6
	2.3	1	1	1	1	1	1

(Extra-small ball bearing : 9 mm or larger in outside diameter and under 10 mm in bore diameter)
 (Miniature ball bearing : under 9 mm in outside diameter)

Table 10-4 Axial internal clearance of matched pair angular contact ball bearings (measurement clearance) ¹⁾

Unit : μm

Nominal bore diameter d , mm		Contact angle : 15°				Contact angle : 30°							
		C 2		C N		C 2		C N		C 3		C 4	
over	up to	min.	max.	min.	max.	min.	max.	min.	max.	min.	max.	min.	max.
–	10	13	33	33	53	3	14	10	30	30	50	50	70
10	18	15	35	35	55	3	16	10	30	30	50	50	70
18	24	20	40	45	65	3	20	20	40	40	60	60	80
24	30	20	40	45	65	3	20	20	40	40	60	60	80
30	40	20	40	45	65	3	20	25	45	45	65	70	90
40	50	20	40	50	70	3	20	30	50	50	70	75	95
50	65	30	55	65	90	9	27	35	60	60	85	90	115
65	80	30	55	70	95	10	28	40	65	70	95	110	135
80	100	35	60	85	110	10	30	50	75	80	105	130	155
100	120	40	65	100	125	12	37	65	90	100	125	150	175
120	140	45	75	110	140	15	40	75	105	120	150	180	210
140	160	45	75	125	155	15	40	80	110	130	160	210	240
160	180	50	80	140	170	15	45	95	125	140	170	235	265
180	200	50	80	160	190	20	50	110	140	170	200	275	305

Nominal bore diameter d , mm		Contact angle : 40°							
		C 2		C N		C 3		C 4	
over	up to	min.	max.	min.	max.	min.	max.	min.	max.
–	10	2	10	6	18	16	30	26	40
10	18	2	12	7	21	18	32	28	44
18	24	2	12	12	26	20	40	30	50
24	30	2	14	12	26	20	40	40	60
30	40	2	14	12	26	25	45	45	65
40	50	2	14	12	30	30	50	50	70
50	65	5	17	17	35	35	60	60	85
65	80	6	18	18	40	40	65	70	95
80	100	6	20	20	45	55	80	85	110
100	120	6	25	25	50	60	85	100	125
120	140	7	30	30	60	75	105	125	155
140	160	7	30	35	65	85	115	140	170
160	180	7	31	45	75	100	130	155	185
180	200	7	37	60	90	110	140	170	200

[Note] 1) Including increase of clearance caused by measurement load.

Table 10-5 Radial internal clearance of double-row angular contact ball bearings

Unit : μm

Nominal bore diameter <i>d</i> , mm		Clearance					
		CD2		CDN		CD3	
over	up to	min.	max.	min.	max.	min.	max.
2.5	10	0	7	2	10	8	18
10	18	0	7	2	11	9	19
18	24	0	8	2	11	10	21
24	30	0	8	2	13	10	23
30	40	0	9	3	14	11	24
40	50	0	10	4	16	13	27
50	65	0	11	6	20	15	30
65	80	0	12	7	22	18	33
80	100	0	12	8	24	22	38
100	120	0	13	9	25	24	42
120	140	0	15	10	26	25	44
140	160	0	16	11	28	26	46
160	180	0	17	12	30	27	47
180	200	0	18	14	32	28	48

[Remark]

Regarding deep groove ball bearings and matched pair and double-row angular contact ball bearings, equations of the relationship between radial internal clearance and axial internal clearance are shown on page A 105.

Table 10-6 Radial internal clearance of self-aligning ball bearings

 Unit : μm

Nominal bore diameter d , mm		Cylindrical bore bearing clearance										Tapered bore bearing clearance									
		C 2		C N		C 3		C 4		C 5		C 2		C N		C 3		C 4		C 5	
over	up to	min.	max.	min.	max.	min.	max.	min.	max.	min.	max.	min.	max.	min.	max.	min.	max.	min.	max.	min.	max.
2.5	6	1	8	5	15	10	20	15	25	21	33	–	–	–	–	–	–	–	–	–	–
6	10	2	9	6	17	12	25	19	33	27	42	–	–	–	–	–	–	–	–	–	–
10	14	2	10	6	19	13	26	21	35	30	48	–	–	–	–	–	–	–	–	–	–
14	18	3	12	8	21	15	28	23	37	32	50	–	–	–	–	–	–	–	–	–	–
18	24	4	14	10	23	17	30	25	39	34	52	7	17	13	26	20	33	28	42	37	55
24	30	5	16	11	24	19	35	29	46	40	58	9	20	15	28	23	39	33	50	44	62
30	40	6	18	13	29	23	40	34	53	46	66	12	24	19	35	29	46	40	59	52	72
40	50	6	19	14	31	25	44	37	57	50	71	14	27	22	39	33	52	45	65	58	79
50	65	7	21	16	36	30	50	45	69	62	88	18	32	27	47	41	61	56	80	73	99
65	80	8	24	18	40	35	60	54	83	76	108	23	39	35	57	50	75	69	98	91	123
80	100	9	27	22	48	42	70	64	96	89	124	29	47	42	68	62	90	84	116	109	144
100	120	10	31	25	56	50	83	75	114	105	145	35	56	50	81	75	108	100	139	130	170
120	140	10	38	30	68	60	100	90	135	125	175	40	68	60	98	90	130	120	165	155	205
140	160	15	44	35	80	70	120	110	161	150	210	45	74	65	110	100	150	140	191	180	240

Table 10-7 Radial internal clearance of electric motor bearings
1) Deep groove ball bearing Unit : μm

Nominal bore diameter d , mm		Clearance	
		CM	
over	up to	min.	max.
10 ¹⁾	18	4	11
18	30	5	12
30	50	9	17
50	80	12	22
80	120	18	30
120	160	24	38

[Note] 1) 10 mm is included.

[Remark] To adjust for change of clearance due to measuring load, use correction values shown in Table 10-2.

2) Cylindrical roller bearing Unit : μm

Nominal bore diameter d , mm		Clearance			
		Interchangeability CT		Non-interchangeability CM	
over	up to	min.	max.	min.	max.
24	40	15	35	15	30
40	50	20	40	20	35
50	65	25	45	25	40
65	80	30	50	30	45
80	100	35	60	35	55
100	120	35	65	35	60
120	140	40	70	40	65
140	160	50	85	50	80
160	180	60	95	60	90
180	200	65	105	65	100

[Note] "Interchangeability" means interchangeable only among products (sub-units) of the same manufacturer ; not with others.

Table 10-8 Radial internal clearance of cylindrical roller bearings and machined ring needle roller bearings

(1) Cylindrical bore bearing

Unit : μm

Nominal bore diameter d , mm		Clearance									
		C 2		C N		C 3		C 4		C 5	
over	up to	min.	max.	min.	max.	min.	max.	min.	max.	min.	max.
–	10	0	25	20	45	35	60	50	75	–	–
10	24	0	25	20	45	35	60	50	75	65	90
24	30	0	25	20	45	35	60	50	75	70	95
30	40	5	30	25	50	45	70	60	85	80	105
40	50	5	35	30	60	50	80	70	100	95	125
50	65	10	40	40	70	60	90	80	110	110	140
65	80	10	45	40	75	65	100	90	125	130	165
80	100	15	50	50	85	75	110	105	140	155	190
100	120	15	55	50	90	85	125	125	165	180	220
120	140	15	60	60	105	100	145	145	190	200	245
140	160	20	70	70	120	115	165	165	215	225	275
160	180	25	75	75	125	120	170	170	220	250	300
180	200	35	90	90	145	140	195	195	250	275	330
200	225	45	105	105	165	160	220	220	280	305	365
225	250	45	110	110	175	170	235	235	300	330	395
250	280	55	125	125	195	190	260	260	330	370	440
280	315	55	130	130	205	200	275	275	350	410	485
315	355	65	145	145	225	225	305	305	385	455	535
355	400	100	190	190	280	280	370	370	460	510	600
400	450	110	210	210	310	310	410	410	510	565	665
450	500	110	220	220	330	330	440	440	550	625	735

(2) Tapered bore bearing

Unit : μm

Nominal bore diameter d , mm		Non-interchangeable clearance													
		C 9 NA ¹⁾		C 1 NA		C 2 NA		C N NA		C 3 NA		C 4 NA		C 5 NA	
over	up to	min.	max.	min.	max.	min.	max.	min.	max.	min.	max.	min.	max.	min.	max.
12	14	5	10	–	–	–	–	–	–	–	–	–	–	–	–
14	24	5	10	10	20	20	30	35	45	45	55	55	65	75	85
24	30	5	10	10	25	25	35	40	50	50	60	60	70	80	95
30	40	5	12	12	25	25	40	45	55	55	70	70	80	95	110
40	50	5	15	15	30	30	45	50	65	65	80	80	95	110	125
50	65	5	15	15	35	35	50	55	75	75	90	90	110	130	150
65	80	10	20	20	40	40	60	70	90	90	110	110	130	150	170
80	100	10	25	25	45	45	70	80	105	105	125	125	150	180	205
100	120	10	25	25	50	50	80	95	120	120	145	145	170	205	230
120	140	15	30	30	60	60	90	105	135	135	160	160	190	230	260
140	160	15	35	35	65	65	100	115	150	150	180	180	215	260	295
160	180	15	35	35	75	75	110	125	165	165	200	200	240	285	320
180	200	20	40	40	80	80	120	140	180	180	220	220	260	315	355
200	225	20	45	45	90	90	135	155	200	200	240	240	285	350	395
225	250	25	50	50	100	100	150	170	215	215	265	265	315	380	430
250	280	25	55	55	110	110	165	185	240	240	295	295	350	420	475
280	315	30	60	60	120	120	180	205	265	265	325	325	385	470	530
315	355	30	65	65	135	135	200	225	295	295	360	360	430	520	585
355	400	35	75	75	150	150	225	255	330	330	405	405	480	585	660
400	450	45	85	85	170	170	255	285	370	370	455	455	540	650	735
450	500	50	95	95	190	190	285	315	410	410	505	505	600	720	815

[Note] 1) Clearance C 9 NA is applied to tapered bore cylindrical roller bearings of JIS tolerance classes 5 and 4.

Table 10-9 Radial internal clearance of spherical roller bearings

(1) Cylindrical bore bearing

Unit : μm

Nominal bore diameter d , mm		Clearance									
		C 2		C N		C 3		C 4		C 5	
over	up to	min.	max.	min.	max.	min.	max.	min.	max.	min.	max.
14	18	10	20	20	35	35	45	45	60	60	75
18	24	10	20	20	35	35	45	45	60	60	75
24	30	15	25	25	40	40	55	55	75	75	95
30	40	15	30	30	45	45	60	60	80	80	100
40	50	20	35	35	55	55	75	75	100	100	125
50	65	20	40	40	65	65	90	90	120	120	150
65	80	30	50	50	80	80	110	110	145	145	180
80	100	35	60	60	100	100	135	135	180	180	225
100	120	40	75	75	120	120	160	160	210	210	260
120	140	50	95	95	145	145	190	190	240	240	300
140	160	60	110	110	170	170	220	220	280	280	350
160	180	65	120	120	180	180	240	240	310	310	390
180	200	70	130	130	200	200	260	260	340	340	430
200	225	80	140	140	220	220	290	290	380	380	470
225	250	90	150	150	240	240	320	320	420	420	520
250	280	100	170	170	260	260	350	350	460	460	570
280	315	110	190	190	280	280	370	370	500	500	630
315	355	120	200	200	310	310	410	410	550	550	690
355	400	130	220	220	340	340	450	450	600	600	750
400	450	140	240	240	370	370	500	500	660	660	820
450	500	140	260	260	410	410	550	550	720	720	900
500	560	150	280	280	440	440	600	600	780	780	1 000
560	630	170	310	310	480	480	650	650	850	850	1 100
630	710	190	350	350	530	530	700	700	920	920	1 190
710	800	210	390	390	580	580	770	770	1 010	1 010	1 300
800	900	230	430	430	650	650	860	860	1 120	1 120	1 440
900	1 000	260	480	480	710	710	930	930	1 220	1 220	1 570

(2) Tapered bore bearing

Unit : μm

Nominal bore diameter <i>d</i> , mm		Clearance									
		C 2		C N		C 3		C 4		C 5	
over	up to	min.	max.	min.	max.	min.	max.	min.	max.	min.	max.
18	24	15	25	25	35	35	45	45	60	60	75
24	30	20	30	30	40	40	55	55	75	75	95
30	40	25	35	35	50	50	65	65	85	85	105
40	50	30	45	45	60	60	80	80	100	100	130
50	65	40	55	55	75	75	95	95	120	120	160
65	80	50	70	70	95	95	120	120	150	150	200
80	100	55	80	80	110	110	140	140	180	180	230
100	120	65	100	100	135	135	170	170	220	220	280
120	140	80	120	120	160	160	200	200	260	260	330
140	160	90	130	130	180	180	230	230	300	300	380
160	180	100	140	140	200	200	260	260	340	340	430
180	200	110	160	160	220	220	290	290	370	370	470
200	225	120	180	180	250	250	320	320	410	410	520
225	250	140	200	200	270	270	350	350	450	450	570
250	280	150	220	220	300	300	390	390	490	490	620
280	315	170	240	240	330	330	430	430	540	540	680
315	355	190	270	270	360	360	470	470	590	590	740
355	400	210	300	300	400	400	520	520	650	650	820
400	450	230	330	330	440	440	570	570	720	720	910
450	500	260	370	370	490	490	630	630	790	790	1 000
500	560	290	410	410	540	540	680	680	870	870	1 100
560	630	320	460	460	600	600	760	760	980	980	1 230
630	710	350	510	510	670	670	850	850	1 090	1 090	1 360
710	800	390	570	570	750	750	960	960	1 220	1 220	1 500
800	900	440	640	640	840	840	1 070	1 070	1 370	1 370	1 690
900	1 000	490	710	710	930	930	1 190	1 190	1 520	1 520	1 860

Table 10-10 Radial internal clearance of double/four-row and matched pair tapered roller bearings (cylindrical bore)

Unit : μm

Nominal bore diameter d , mm		Clearance									
		C 1		C 2		C N		C 3		C 4	
over	up to	min.	max.	min.	max.	min.	max.	min.	max.	min.	max.
14	18	0	10	10	20	20	30	30	40	40	50
18	24	0	10	10	20	20	30	30	40	40	55
24	30	0	10	10	20	20	30	30	45	45	60
30	40	0	12	12	25	25	40	40	55	55	75
40	50	0	15	15	30	30	45	45	60	60	80
50	65	0	15	15	30	30	50	50	70	70	90
65	80	0	20	20	40	40	60	60	80	80	110
80	100	0	20	20	45	45	70	70	100	100	130
100	120	0	25	25	50	50	80	80	110	110	150
120	140	0	30	30	60	60	90	90	120	120	170
140	160	0	30	30	65	65	100	100	140	140	190
160	180	0	35	35	70	70	110	110	150	150	210
180	200	0	40	40	80	80	120	120	170	170	230
200	225	0	40	40	90	90	140	140	190	190	260
225	250	0	50	50	100	100	150	150	210	210	290
250	280	0	50	50	110	110	170	170	230	230	320
280	315	0	60	60	120	120	180	180	250	250	350
315	355	0	70	70	140	140	210	210	280	280	390
355	400	0	70	70	150	150	230	230	310	310	440
400	450	0	80	80	170	170	260	260	350	350	490
450	500	0	90	90	190	190	290	290	390	390	540
500	560	0	100	100	210	210	320	320	430	430	590
560	630	0	110	110	230	230	350	350	480	480	660
630	710	0	130	130	260	260	400	400	540	540	740
710	800	0	140	140	290	290	450	450	610	610	830
800	900	0	160	160	330	330	500	500	670	670	920

Table 10-11 Examples of non-standard clearance selection

Service conditions	Applications	Examples of clearance selection
In the case of heavy/impact load, large interference	Railway rolling stock axle journals	C 3
In the case of vibration/impact load, interference fit both for inner/outer rings	Shaker screens, railway rolling stock traction motors, tractor final reduction gears	C 3, C 4 C 4 C 4
When shaft deflection is large	Automobile rear wheels	C 5
When shaft and inner ring are heated	Dryers of paper making machines, table rollers of rolling mills	C 3, C 4 C 3
When clearance fit both for inner/outer rings	Roll necks of rolling mills	C 2
When noise/vibration during rotation is to be lowered	Micro-motors	C 1, C 2, CM
When clearance after mounting is to be adjusted in order to reduce shaft runout	Lathe spindles	C 9 NA, C 1 NA

[Reference] Relationship between radial internal clearance and axial internal clearance

[Deep groove ball bearing] $\Delta_a = \sqrt{\Delta_r (4m_o - \Delta_r)}$ (10-1)

[Double-row angular contact ball bearing] $\Delta_a = 2\sqrt{m_o^2 - (m_o \cos \alpha - \frac{\Delta_r}{2})^2} - 2m_o \sin \alpha$ (10-2)

[Matched pair angular contact ball bearing] $\Delta_a = 2m_o \sin \alpha - 2\sqrt{m_o^2 - (m_o \cos \alpha + \frac{\Delta_r}{2})^2}$ (10-3)

[Double/four-row and matched pair tapered roller bearing] $\Delta_a = \Delta_r \cot \alpha \div \frac{1.5}{e} \Delta_r$ (10-4)

where :

Δ_a : axial internal clearance mm

α : nominal contact angle

Δ_r : radial internal clearance mm

e : limit value of F_a/F_r

$m_o = r_e + r_i - D_w$

$\left(\begin{array}{ll} r_e : \text{outer ring raceway groove radius} & \text{mm} \\ r_i : \text{inner ring raceway groove radius} & \text{mm} \\ D_w : \text{ball diameter} & \text{mm} \end{array} \right)$

(shown in the bearing specification table.)

11. Preload

Generally, bearings are operated with a certain amount of proper clearance allowed. For some applications, however, bearings are mounted with axial load of such magnitude that the clearance will be negative.

The axial load, referred to as "preload," is often applied to angular contact ball bearings and tapered roller bearings.

11-1 Purpose of preload

- To improve running accuracy by reducing runout of shaft, as well as to heighten position accuracy in radial and axial directions. (Bearings for machine tool spindles and measuring instruments)
- To improve gear engagement accuracy by increasing bearing rigidity. (Bearings for automobile final reduction gears)
- To reduce smearing by eliminating sliding in irregular rotation, self-rotation, and around-the-raceway revolution of rolling elements. (For high rotation-speed angular contact ball bearings)
- To minimize abnormal noise due to vibration or resonance. (For small electric motor bearings)
- To keep rolling elements in the right position relative to the raceway. (For thrust ball bearings and spherical thrust roller bearings used on horizontal shafts)

11-2 Method of preloading

The preload can be done either by the position preloading or the constant pressure preloading; typical examples are given in Table 11-1.

(Comparison between position and constant pressure preloadings)

- With the same amount of preloading, the position preloading produces smaller displacement in the axial direction, and thus is liable to bring about higher rigidity.
- The constant pressure preloading produces stable preloading, or little fluctuation in the amount of preload, since the spring can absorb the load fluctuation and shaft expansion/contraction caused by temperature difference between the shaft and housing during operation.
- The position preloading can apply a larger preload.

Consequently, the position preloading is more suitable for applications requiring high rigidity, while the constant pressure preloading is more suitable for high rotational speed, vibration prevention in the axial direction, and thrust bearings used on horizontal shafts.

Table 11-1 Method of preloading

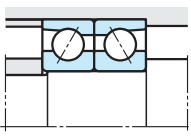
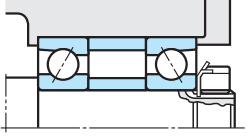
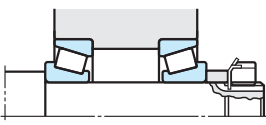
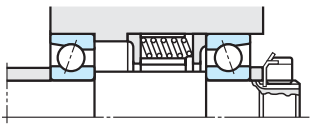
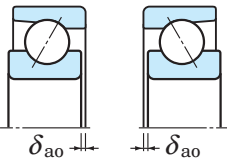
Position preloading		Constant pressure preloading	
			
<ul style="list-style-type: none"> ● Method using matched pair bearing with stand-out adjusted for preloading (see below). 	<ul style="list-style-type: none"> ● Method using spacer with dimensions adjusted for preloading. 	<ul style="list-style-type: none"> ● Method using nut or bolt capable of adjusting preload in axial direction. <p>(In this case, starting friction moment during adjustment should be measured so that proper preload will be applied.)</p>	<ul style="list-style-type: none"> ● Method using coil spring or diaphragm spring.

11-3 Preload and rigidity

For angular contact ball bearings and tapered roller bearings, the "back-to-back" arrangement is generally used to apply preload for higher rigidity.

This is because shaft rigidity is improved by the longer distance between load centers in the back-to-back arrangement.

Fig. 11-1 shows the relationship between preload given via position preloading and rigidity expressed by displacement in the axial direction of the back-to-back bearing.

P : amount of preload (load)
 T : axial load from outside
 T_A : axial load applied to Bearing A
 T_B : axial load applied to Bearing B
 δ_a : displacement of matched pair bearing
 δ_{aA} : displacement of Bearing A
 δ_{aB} : displacement of Bearing B
 $2 \delta_{ao}$: clearance between inner rings before preloading

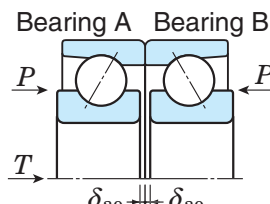

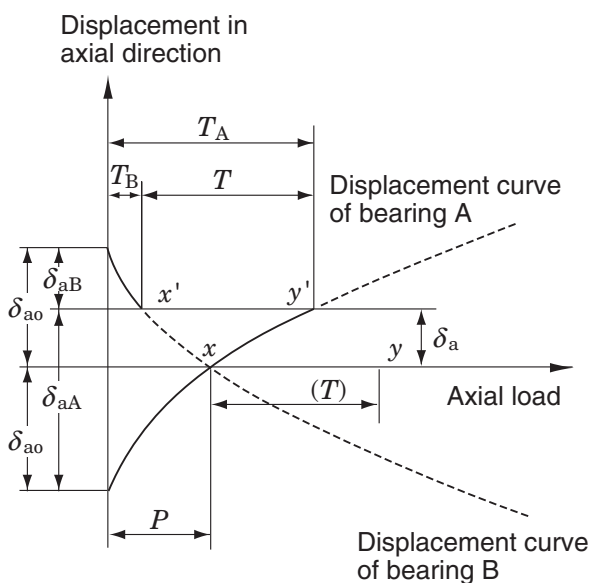

Fig. 11-1 Preloading diagram in position preloading

In Fig. 11-1, when preload P is applied (inner ring is tightened toward the axial direction), bearings A and B are displaced by δ_{ao} respectively, and the clearance between inner rings diminishes from $2\delta_{ao}$ to zero.

The displacement when axial load T is applied to these matched pair bearings from the outside can be determined as δ_a .

[For reference]

How to determine δ_a in Fig. 11-1

- ① Determine the displacement curve of bearing A.
- ② Determine the displacement curve of bearing B. ...Symmetrical curve in relation to horizontal axis intersecting vertical line of preload P at point x .
- ③ With the load from outside defined as T , determine line segment $x - y$ on the horizontal line passing through point x . Displace segment $x - y$ in parallel along the displacement curve of bearing B. Determine point y' at which to intersect displacement curve of bearing A.
- ④ δ_a can be determined as the distance between line segments $x' - y'$ and $x - y$.

Fig. 11-2 shows the relationship between preload and rigidity in the constant pressure preloading using the same matched pair bearings as in Fig. 11-1.

In this case, since the spring rigidity can be ignored, the matched pair bearing shows almost the same rigidity as a separate bearing with preload P applied in advance.

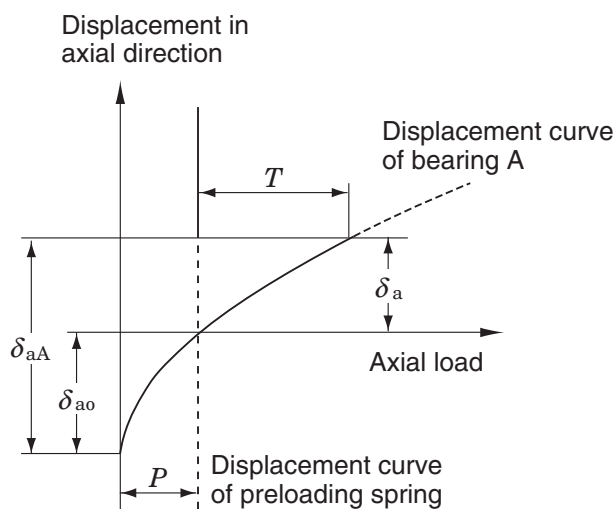

Fig. 11-2 Preloading diagram in constant pressure preloading

11-4 Amount of preload

The amount of preload should be determined, to avoid an adverse effect on bearing life, temperature rise, friction torque, or other performance characteristic, in view of the bearing application.

Decrease of preload due to wear-in, accuracy of the shaft and housing, mounting conditions, and lubrication should also be fully considered in determining preload.

11-4-1 Preload amount of matched pair angular contact ball bearings

Table 11-2 shows recommended preload for matched pair angular contact ball bearings of JIS class 5 or higher used for machine tool spindles or other higher precision applications.

JTEKT offers four types of standard preload: slight preload (S), light preload (L), medium preload (M), and heavy preload (H), so that preload can be selected properly and easily for various applications.

Generally, light or medium preload is recommended for grinder spindles, and medium or heavy preload for spindles of lathes and milling machines.

Table 11-3 shows recommended fits of high-precision matched pair angular contact ball bearings used with light or medium preload applied.

Table 11-2 Standard preload of high-precision matched pair angular contact ball bearings

Bore diameter No.	7900 C			7000			7000 C				7200			
	S	L	M	L	M	H	S	L	M	H	L	M	H	
00	5	15	30	30	80	145	6	20	50	100	50	145	245	
01	7	20	40	30	80	145	6	20	50	100	60	145	295	
02	8	25	50	50	145	245	10	30	80	145	80	245	390	
03	8	25	50	60	145	295	15	40	100	165	100	245	540	
04	15	40	80	60	145	295	15	40	100	245	145	295	635	
05	15	50	100	100	245	490	20	60	145	295	145	390	785	
06	15	50	100	145	295	635	25	80	195	390	145	590	930	
07	25	70	140	145	390	785	35	100	245	490	245	785	1 270	
08	25	80	155	145	390	785	35	100	295	590	390	880	1 570	
09	35	100	195	245	540	980	50	145	345	635	490	1 080	1 770	
10	35	100	195	245	635	1 180	50	145	390	735	540	1 180	2 060	
11	40	120	235	295	785	1 370	65	195	440	880	635	1 370	2 450	
12	40	120	235	390	880	1 570	65	195	490	980	785	1 470	2 940	
13	50	145	295	440	980	1 770	85	245	540	1 090	835	1 670	3 330	
14	65	195	390	490	1 080	2 060	85	245	635	1 270	930	1 860	3 720	
15	65	195	390	590	1 180	2 150	100	295	685	1 370	980	2 150	3 920	
16	65	195	390	635	1 370	2 350	100	295	735	1 470	1 080	2 450	4 310	
17	85	245	490	735	1 570	2 550	130	390	880	1 770	1 270	2 940	4 900	
18	100	295	590	785	1 670	2 840	145	440	980	1 960	1 470	3 230	5 390	
19	100	295	590	880	1 770	3 140	160	490	1 080	2 060	1 670	3 430	5 880	
20	100	345	685	880	1 960	3 530	175	540	1 180	2 150	1 860	3 920	6 370	
21	100	345	685	980	2 150	3 920	195	590	1 270	2 350	2 060	4 310	7 060	
22	145	390	785	1 080	2 380	4 410	210	635	1 470	2 550	2 250	4 900	7 840	
24	145	490	980	1 180	2 650	4 900	225	685	1 670	2 840	2 450	5 390	8 820	
26	195	590	1 180	1 370	3 140	5 390	245	735	1 770	3 140	2 750	5 880	9 310	
28	195	635	1 270	1 470	3 430	5 880	260	785	1 960	3 920	2 940	6 370	9 800	
30	245	735	1 470	1 770	3 920	6 860	275	835	2 150	4 410	3 330	6 860	10 300	
32	245	785	1 570	2 150	4 410	7 840	290	880	2 350	4 900	3 630	7 350	10 800	
34	345	880	1 810	2 450	4 900	8 820	325	980	2 450	5 390	3 920	7 840	11 800	

Table 11-3 Recommended fits for high-precision matched pair angular contact ball bearings with preload applied

(1) Dimensional tolerance of shaft Unit : μm

Shaft diameter mm		Inner ring rotation		Outer ring rotation
		Tolerance of shaft diameter	Interference between shaft and inner ring (matching adjustment) ¹⁾	Tolerance of shaft diameter
over	up to			
6	10	-2 -6	0-2	0 -4
10	18	-2 -7	0-2	0 -5
18	30	-2 -8	0-2.5	0 -6
30	50	-2 -9	0-2.5	0 -7
50	80	-2 -10	0-3	0 -8
80	120	-2 -12	0-4	0 -10
120	180	-2 -14	0-5	0 -12

[Note] 1) Matching adjustment means to measure of bore diameter the bearing and match it to the measured shaft diameter.

(2) Dimensional tolerance of housing bore Unit : μm

Housing bore diameter mm		Inner ring rotation			Outer ring rotation
		Tolerance of housing bore diameter		Clearance ¹⁾ between housing and outer ring	Tolerance of housing bore diameter
over	up to	Fixed-side bearing	Free-side bearing		
18	30	± 4.5	+9 0	2-6	-6 -12
30	50	± 5.5	+11 0	2-6	-6 -13
50	80	± 6.5	+13 0	3-8	-8 -16
80	120	± 7.5	+15 0	3-9	-9 -19
120	180	± 9	+18 0	4-12	-11 -23
180	250	± 10	+20 0	5-15	-13 -27
250	315	± 11.5	+23 0	6-18	-16 -32

[Note] 1) Lower value is desirable for fixed side; higher value for free side.

[S : slight preload, L : light preload, M : medium preload, H : heavy preload] Unit : N

	7200 C				ACT 000		ACT 000 B		Bore diameter No.
	S	L	M	H	L	M	L	M	
	10	30	80	145	-	-	-	-	00
	15	40	100	195	-	-	-	-	01
	15	50	145	245	-	-	-	-	02
	25	70	145	345	-	-	-	-	03
	25	80	195	390	-	-	-	-	04
	35	100	245	490	-	-	-	-	05
	35	100	295	590	195	345	295	685	06
	50	145	390	785	195	390	390	735	07
	65	195	440	880	245	440	440	835	08
	85	245	540	1 080	245	490	490	930	09
	85	245	590	1 180	295	540	540	1 030	10
	100	295	735	1 470	390	685	685	1 270	11
	115	345	785	1 670	390	735	735	1 420	12
	130	390	930	1 860	440	835	785	1 520	13
	160	490	980	2 060	590	1 130	1 030	2 010	14
	195	590	1 180	2 350	590	1 130	1 080	2 110	15
	225	685	1 370	2 750	685	1 370	1 270	2 500	16
	260	785	1 570	2 940	735	1 420	1 320	2 600	17
	260	785	1 770	3 430	980	1 860	1 770	3 380	18
	290	880	1 960	3 920	980	1 960	1 860	3 530	19
	325	980	2 150	4 410	1 030	2 010	1 910	3 680	20
	360	1 080	2 350	4 900	1 180	2 250	2 150	3 770	21
	385	1 180	2 450	5 290	1 320	2 600	2 450	4 760	22
	420	1 270	2 840	5 490	1 420	2 800	2 550	5 100	24
	485	1 470	3 140	5 880	1 770	3 380	3 230	6 230	26
	520	1 570	3 430	6 370	2 010	3 920	3 720	7 210	28
	585	1 770	3 720	6 860	2 500	4 850	4 660	8 920	30
	645	1 960	4 120	7 840	2 500	4 850	4 660	8 920	32
	645	2 150	4 410	8 330	3 090	6 030	5 730	11 100	34

11-4-2 Amount of preload for thrust ball bearings

When a thrust ball bearing is rotated at high speed, balls slide on raceway due to centrifugal force and the gyro moment, which often causes the raceway to suffer from smearing or other defects.

To eliminate such sliding, it is necessary to mount the bearing without clearance, and apply an axial load (preload) larger than the minimum necessary axial load determined by the following equation.

When an axial load from the outside is lower than $0.0013 C_{0a}$, there is no adverse effect on the bearing, as long as lubrication is satisfactory.

Generally, deep groove and angular contact ball bearings are recommended for applications when a portion of rotation under axial load is present at high speed.

11-4-3 Amount of preload for spherical thrust roller bearings

Spherical thrust roller bearings sometimes suffer from scuffing, smearing, or other defects due to sliding which occurs between the roller and raceway surface in operation.

To eliminate such sliding, it is necessary to mount the bearing without clearance, and apply an axial load (preload) larger than the minimum necessary axial load.

Of the two values determined by the two equations below, the higher should be defined as the minimum necessary axial load.

- Thrust ball bearing (contact angle : 90°)

$$F_{a \min} = 5.1 \left(\frac{n}{1\ 000} \right)^2 \cdot \left(\frac{C_{0a}}{1\ 000} \right)^2 \times 10^{-3} \dots\dots\dots (11-1)$$

- Spherical thrust roller bearing (the higher value determined by the two equations should be taken.)

$$F_{a \min} = \frac{C_{0a}}{2\ 000} \dots\dots\dots (11-2)$$

$$F_{a \min} = 1.8F_r + 1.33 \left(\frac{n}{1\ 000} \right)^2 \cdot \left(\frac{C_{0a}}{1\ 000} \right)^2 \times 10^{-4} \dots\dots\dots (11-3)$$

where :

- $F_{a \min}$: minimum necessary axial load N
- n : rotational speed min⁻¹
- C_{0a} : static axial load rating N
- F_r : radial load N

12. Bearing lubrication

12-1 Purpose and method of lubrication

Lubrication is one of the most important factors determining bearing performance. The suitability of the lubricant and lubrication method have a dominant influence on bearing life.

Functions of lubrication :

- To lubricate each part of the bearing, and to reduce friction and wear
- To carry away heat generated inside bearing due to friction and other causes
- To cover rolling contact surface with the proper oil film in order to prolong bearing fatigue life
- To prevent corrosion and contamination by dirt

Bearing lubrication is classified broadly into two categories: grease lubrication and oil lubrication. Table 12-1 makes a general comparison between the two.

Table 12-1 Comparison between grease and oil lubrication

Item	Grease	Oil
· Sealing device	Easy	Slightly complicated and special care required for maintenance
· Lubricating ability	Good	Excellent
· Rotation speed	Low/medium speed	Applicable at high speed as well
· Replacement of lubricant	Slightly troublesome	Easy
· Life of lubricant	Relatively short	Long
· Cooling effect	No cooling effect	Good (circulation is necessary)
· Filtration of dirt	Difficult	Easy

12-1-1 Grease lubrication

Grease lubrication is widely applied since there is no need for replenishment over a long period once grease is filled, and a relatively simple structure can suffice for the lubricant sealing device.

There are two methods of grease lubrication. One is the closed lubrication method, in which grease is filled in advance into shielded/sealed bearing; the other is the feeding method, in which the bearing and housing are filled with grease in proper quantities at first, and refilled at a regular interval via replenishment or replacement.

Devices with numerous grease inlets sometimes employ the centralized lubricating method, in which the inlets are connected via piping and supplied with grease collectively.

1) Amount of grease

In general, grease should fill approximately one-third to one-half the inside space, though this varies according to structure and inside space of housing.

It must be borne in mind that excessive grease will generate heat when churned, and will consequently alter, deteriorate, or soften.

When the bearing is operated at low speed, however, the inside space is sometimes filled with grease to two-thirds to full, in order to preclude infiltration of contaminants.

2) Replenishment/replacement of grease

The method of replenishing/replacing grease depends largely on the lubrication method. Whichever method may be utilized, care should be taken to use clean grease and to keep dirt or other foreign matter out of the housing.

In addition, it is desirable to refill with grease of the same brand as that filled at the start.

When grease is refilled, new grease must be injected inside bearing.

Fig. 12-1 gives one example of a feeding method.

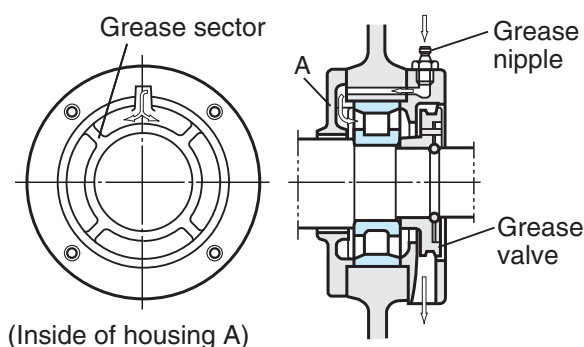

Fig. 12-1 Example of grease feeding method (using grease sector)

In the example, the inside of the housing is divided by grease sectors. Grease fills one sector, then flows into the bearing.

On the other hand, grease flowing back from the inside is forced out of the bearing by the centrifugal force of the grease valve.

When the grease valve is not used, it is necessary to enlarge the housing space on the discharge side to store old grease.

The housing is uncovered and the stored old grease is removed at regular intervals.

3) Grease feeding interval

In normal operation, grease life should be regarded roughly as shown in Fig. 12-2, and replenishment/replacement should be carried out accordingly.

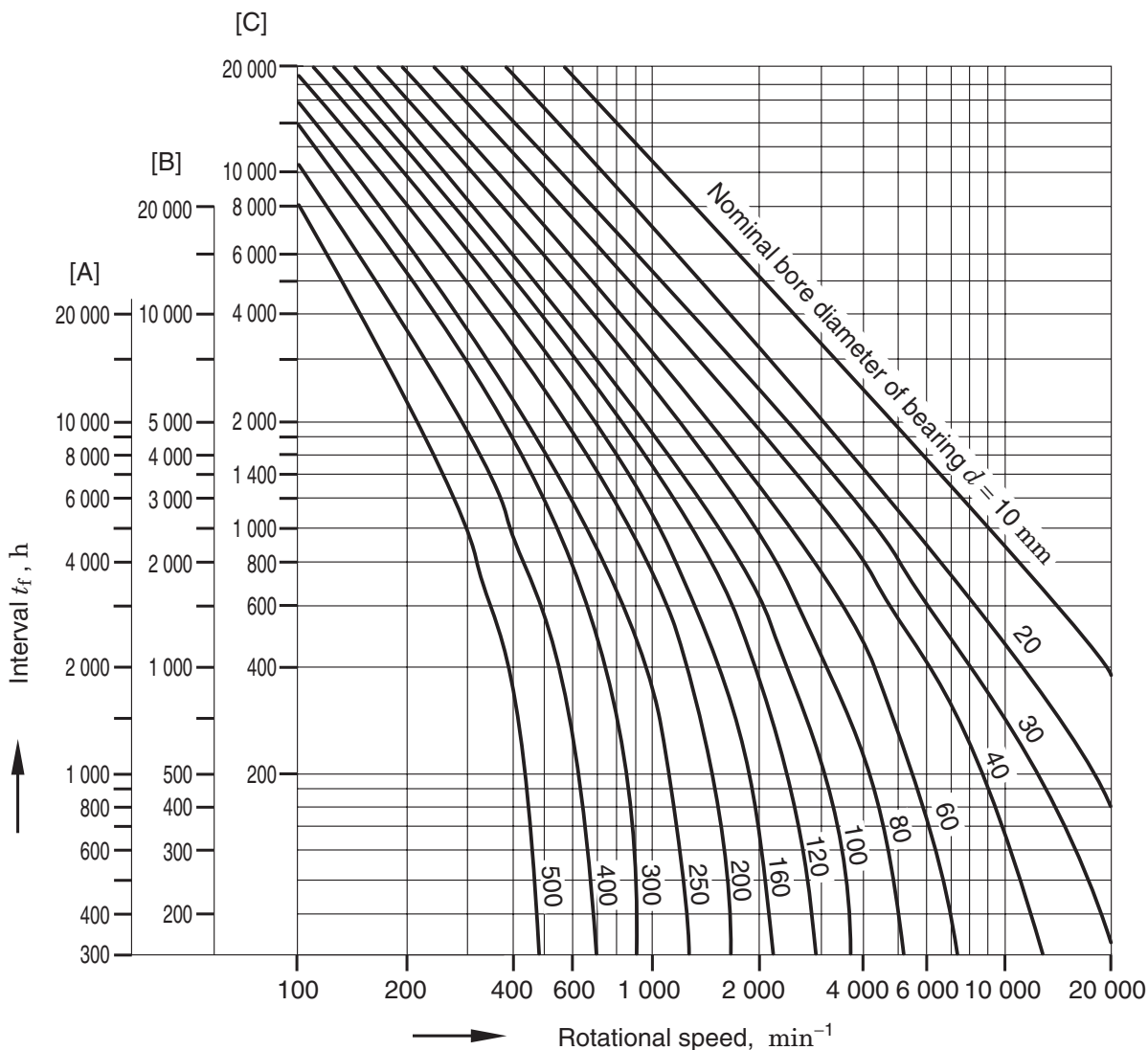

[Notes] 1) [A] : radial ball bearing

[B] : cylindrical roller bearing, needle roller bearing

[C] : tapered roller bearing, spherical roller bearing, thrust ball bearing

2) Temperature correction

When the bearing operating temperature exceeds 70°C , t_f' , obtained by multiplying t_f by correction coefficient a , found on the scale below, should be applied as the feeding interval.

$$t_f' = t_f \times a$$

Temperature correction coefficient a

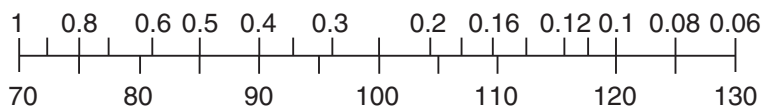

Fig. 12-2 Grease feeding interval

4) Grease life in shielded/sealed ball bearing

Grease life can be estimated by the following equation when a single-row deep groove ball bearing is filled with grease and sealed with shields or seals.

$$\log L = 6.10 - 4.40 \times 10^{-6} d_m n - 2.50 \left(\frac{P_r}{C_r} - 0.05 \right) - (0.021 - 1.80 \times 10^{-8} d_m n) T \dots (12-1)$$

where :

L : grease life h

$d_m = \frac{D+d}{2}$ (D : outside diameter, d : bore diameter) mm

n : rotational speed min⁻¹

P_r : dynamic equivalent radial load N

C_r : basic dynamic radial load rating N

T : operating temperature of bearing °C

The conditions for applying equation (12-1) are as follows :

a) Operating temperature of bearing : T °C

Applicable when $T \leq 120$

$\left(\begin{array}{l} \text{when } T < 50, \\ T = 50 \end{array} \right)$

When $T > 120$, please contact with JTEKT.

c) Load condition : $\frac{P_r}{C_r}$

Applicable when $\frac{P_r}{C_r} \leq 0.2$

$\left(\begin{array}{l} \text{when } \frac{P_r}{C_r} < 0.05, \\ \frac{P_r}{C_r} = 0.05 \end{array} \right)$

When $\frac{P_r}{C_r} > 0.2$, please contact with JTEKT.

b) Value of $d_m n$

Applicable when $d_m n \leq 500 \times 10^3$

$\left(\begin{array}{l} \text{when } d_m n < 125 \times 10^3, \\ d_m n = 125 \times 10^3 \end{array} \right)$

When $d_m n > 500 \times 10^3$, please contact with JTEKT.

12-1-2 Oil lubrication

Oil lubrication is usable even at high speed rotation and somewhat high temperature, and is effective in reducing bearing vibration and noise.

Thus oil lubrication is used in many cases where grease lubrication does not work.

Table 12-2 shows major types and methods of oil lubrication.

Table 12-2 Type and method of oil lubrication

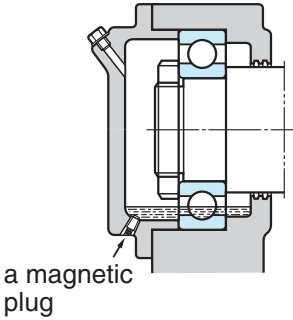
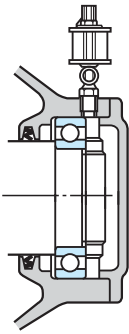
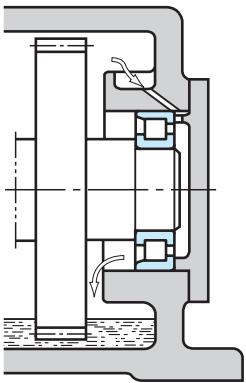
<p>① Oil bath</p>	<ul style="list-style-type: none"> ● Simplest method of bearing immersion in oil for operation. ● Suitable for low/medium speed. ● Oil level gauge should be furnished to adjust the amount of oil. (In the case of horizontal shaft) About 50 % of the lowest rolling element should be immersed. (In the case of vertical shaft) About 70 to 80 % of the bearing should be immersed. ● It is better to use a magnetic plug to prevent wear iron particles from dispersing in oil. 	 <p>a magnetic plug</p>
<p>② Oil drip</p>	<ul style="list-style-type: none"> ● Oil is dripped with an oiling device, and the inside of the housing is filled with oil mist by the action of rotating parts. This method has a cooling effect. ● Applicable at relatively high speed and up to medium load. ● In general, 5 to 6 drops of oil are utilized per minute. (It is difficult to adjust the dripping in 1mL/h or smaller amounts.) ● It is necessary to prevent too much oil from being accumulated at the bottom of housing. 	
<p>③ Oil splash</p>	<ul style="list-style-type: none"> ● This type of lubrication method makes use of a gear or simple flinger attached to shaft in order to splash oil. This method can supply oil for bearings located away from the oil tank. ● Usable up to relatively high speed. ● It is necessary to keep oil level within a certain range. ● It is better to use a magnetic plug to prevent wear iron particles from dispersing in oil. It is also advisable to set up a shield or baffle board to prevent contaminants from entering the bearing. 	

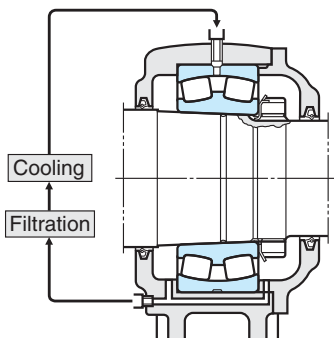
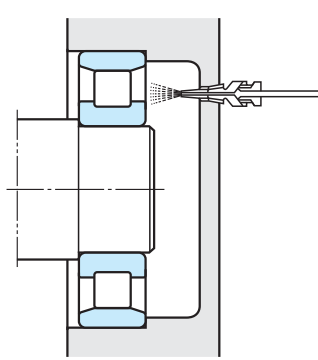
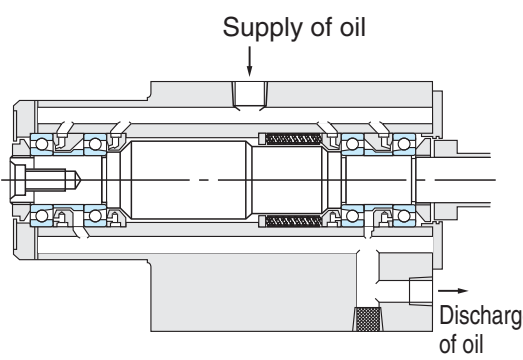
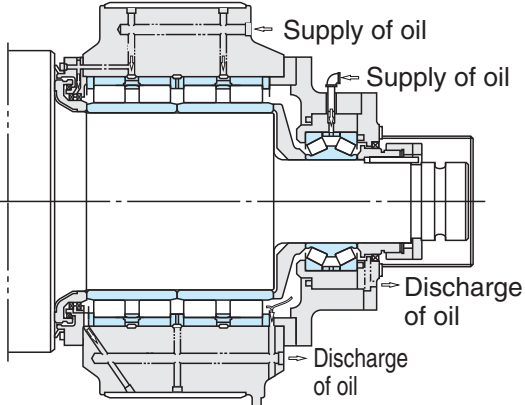
<p>④ Forced oil circulation</p>	<ul style="list-style-type: none"> ● This method employs a circulation-type oil supply system. Supplied oil lubricates inside of the bearing, is cooled and sent back to the tank through an oil escape pipe. The oil, after filtering and cooling, is pumped back. ● Widely used at high speeds and high temperature conditions. ● It is better to use an oil escape pipe approximately twice as thick as the oil supply pipe in order to prevent too much lubricant from gathering in housing. ● Required amount of oil : see Remark 1. 	
<p>⑤ Oil jet lubrication</p>	<ul style="list-style-type: none"> ● This method uses a nozzle to jet oil at a constant pressure (0.1 to 0.5MPa), and is highly effective in cooling. ● Suitable for high speed and heavy load. ● Generally, the nozzle (diameter 0.5 to 2 mm) is located 5 to 10 mm from the side of a bearing. When a large amount of heat is generated, 2 to 4 nozzles should be used. ● Since a large amount of oil is supplied in the jet lubrication method, old should be discharged with an oil pump to prevent excessive residual oil. ● Required amount of oil : see Remark 1. 	
<p>⑥ Oil mist lubrication (spray lubrication)</p>	<ul style="list-style-type: none"> ● This method employs an oil mist generator to produce dry mist (air containing oil in the form of mist). The dry mist is continuously sent to the oil supplier, where the mist is turned into a wet mist (sticky oil drops) by a nozzle set up on the housing or bearing, and is then sprayed onto bearing. ● Required amount of mist : see Remark 2. <p>(Example of grinding machine)</p> 	<ul style="list-style-type: none"> ● This method provides and sustains the smallest amount of oil film necessary for lubrication, and has the advantages of preventing oil contamination, simplifying bearing maintenance, prolonging bearing fatigue life, reducing oil consumption etc. <p>(Example of rolling mill)</p> 

⑦
Oil/air
lubrication

- A proportioning pump sends forth a small quantity of oil, which is mixed with compressed air by a mixing valve. The admixture is supplied continuously and stably to the bearing.
- This method enables quantitative control of oil in extremely small amounts, always supplying new lubricating oil. It is thus suitable for machine tools and other applications requiring high speed.
- Compressed air and lubricating oil are supplied to the spindle, increasing the internal pressure and helping prevent dirt, cutting-liquid, etc. from entering. As well, this method allows the lubricating oil to flow through a feeding pipe, minimizing atmospheric pollution.
- JTEKT produces an oil/air lubricator and, air cleaner, as well as a spindle unit incorporating the oil/air lubrication system. Please refer to brochure "oil/air lubricator & air clean unit".

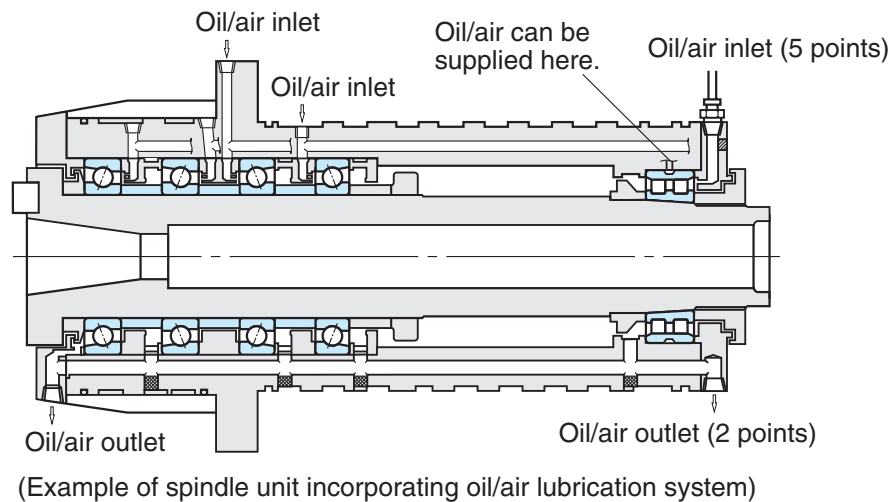

Remark 1 Required oil supply in forced oil circulation ; oil jet lubrication methods

$$G = \frac{1.88 \times 10^{-4} \mu \cdot d \cdot n \cdot P}{60 \cdot c \cdot r \cdot \Delta T}$$

where :

- G : required oil supply L/min
- μ : friction coefficient (see table at right)
- d : nominal bore diameter mm
- n : rotational speed min⁻¹
- P : dynamic equivalent load of bearing N
- c : specific heat of oil 1.88-2.09kJ/kg·K
- r : density of oil g/cm³
- ΔT : temperature rise of oil K

Values of friction coefficient μ

Bearing type	μ
Deep groove ball bearing	0.001 0 – 0.001 5
Angular contact ball bearing	0.001 2 – 0.002 0
Cylindrical roller bearing	0.000 8 – 0.001 2
Tapered roller bearing	0.001 7 – 0.002 5
Spherical roller bearing	0.002 0 – 0.002 5

The values obtained by the above equation show quantities of oil required to carry away all the generated heat, with heat release not taken into consideration.

In reality, the oil supplied is generally half to two-thirds of the calculated value.

Heat release varies widely according to the application and operating conditions.

To determine the optimum oil supply, it is advised to start operating with two-thirds of the calculated value, and then reduce the oil gradually while measuring the operating temperature of bearing, as well as the supplied and discharged oil.

Remark 2 Notes on oil mist lubrication

1) Required amount of mist (mist pressure : 5 kPa)

$$\text{(In the case of a bearing)} \quad Q = \frac{0.11dR}{1\,000}$$

$$\text{(In the case of two oil seals combined)} \quad Q = \frac{0.028d_1}{1\,000}$$

where :

Q : required amount of mist L/min

d : nominal bore diameter mm

R : number of rolling element rows

d_1 : inside diameter of oil seal mm

In the case of high speed ($d_m n \geq 400 \times 10^3$), it is necessary to increase the amount of oil and heighten the mist pressure.

2) Piping diameter and design of lubrication hole/groove

When the flow rate of mist in piping exceeds 5 m/s, oil mist suddenly condenses into an oil liquid.

Consequently, the piping diameter and dimensions of the lubrication hole/groove in the housing should be designed to keep the flow rate of mist, obtained by the following equation, from exceeding 5 m/s.

$$V = \frac{0.167Q}{A} \leq 5$$

where :

V : flow rate of mist m/s

Q : amount of mist L/min

A : sectional area of piping or
lubrication groove cm²

3) Mist oil

Oil used in oil mist lubrication should meet the following requirements.

- ability to turn into mist
- has high extreme pressure resistance
- good heat/oxidation stability
- rust-resistant
- unlikely to generate sludge
- superior demulsifier

Oil mist lubrication has a number of advantages for high speed rotation bearings. Its performance, however, is largely affected by surrounding structures and bearing operating conditions.

If contemplating the use of this method, please contact with JTEKT for advice based on JTEKT long experience with oil mist lubrication.

12-2 Lubricant

12-2-1 Grease

Grease is made by mixing and dispersing a solid of high oil-affinity (called a thickener) with lubricant oil (as a base), and transforming it into a semi-solid state.

As well, a variety of additives can be added to improve specific performance.

(1) Base oil

Mineral oil is usually used as the base oil for grease. When low temperature fluidity, high temperature stability, or other special performance is required, diester oil, silicon oil, polyglycolic oil, fluorinated oil, or other synthetic oil is often used.

Generally, grease with a low viscosity base oil is suitable for applications at low temperature or high rotation speed; grease with high viscosity base oils are suitable for applications at high temperature or under heavy load.

(2) Thickener

Most greases use a metallic soap base such as lithium, sodium, or calcium as thickeners. For some applications, however, non-soap base thickeners (inorganic substances such as bentonite, silica gel, and organic substances such as urea compounds, fluorine compounds) are also used.

In general, the mechanical stability, bearing operating temperature range, water resistance, and other characteristics of grease are determined by the thickener.

(Lithium soap base grease)

Superior in heat resistance, water resistance and mechanical stability.

(Calcium soap base grease)

Superior in water resistance; inferior in heat resistance.

(Sodium soap base grease)

Superior in heat resistance; inferior in water resistance.

(Non-soap base grease)

Superior in heat resistance.

Table 12-3 Characteristics of respective greases

	Lithium grease			Calcium grease (cup grease)	Sodium grease (fiber grease)
Thickener	Lithium soap			Calcium soap	Sodium soap
Base oil	Mineral oil	Synthetic oil (diester oil)	Synthetic oil (silicon oil)	Mineral oil	Mineral oil
Dropping point (°C)	170 to 190	170 to 230	220 to 260	80 to 100	160 to 180
Operating temperature range (°C)	- 30 to + 120	- 50 to + 130	- 50 to + 180	- 10 to + 70	0 to + 110
Rotation speed range	Medium to high	High	Low to medium	Low to medium	Low to high
Mechanical stability	Excellent	Good to excellent	Good	Fair to good	Good to excellent
Water resistance	Good	Good	Good	Good	Bad
Pressure resistance	Good	Fair	Bad to fair	Fair	Good to excellent
Remarks	Most widely usable for various rolling bearings.	Superior low temperature and friction characteristics. Suitable for bearings for measuring instruments and extra-small ball bearings for small electric motors.	Superior high and low temperature characteristics.	Suitable for applications at low rotation speed and under light load. Not applicable at high temperature.	Liable to emulsify in the presence of water. Used at relatively high temperature.

(3) Additives

Various additives are selectively used to serve the respective purposes of grease applications.

- Extreme pressure agents
When bearings must tolerate heavy or impact loads.
- Oxidation inhibitors
When grease is not refilled for a long period. Structure stabilizers, rust preventives, and corrosion inhibitors are also used.

(4) Consistency

Consistency, which indicates grease hardness, is expressed as a figure obtained, in accordance with ASTM (JIS), by multiplication by 10 the depth (in mm) to which the cone-shaped metallic plunger penetrates into the grease at 25°C by deadweight in 5 seconds. The softer the grease, the higher the figure.

Table 12-4 shows the relationships between the NLGI scales and ASTM (JIS) penetration indexes, service conditions of grease. (NLGI : National Lubricating Grease Institute)

Table 12-4 Grease consistency

NLGI scale	ASTM (JIS) penetration index (25°C, 60 mixing operations)	Service conditions/ applications
0	355 – 385	For centralized lubricating
1	310 – 340	For centralized lubricating, at low temperature
2	265 – 295	For general use
3	220 – 250	For general use, at high temperature
4	175 – 205	For special applications

(5) Mixing of different greases

Since mixing of different greases changes their properties, greases of different brands should not be mixed.

If mixing cannot be avoided, greases containing the same thickener should be used. Even if the mixed greases contain the same thickener, however, mixing may still produce adverse effects, due to difference in additives or other factors.

Thus it is necessary to check the effects of a mixture in advance, through testing or other methods.

Complex base grease		Non-soap base grease			
Lithium complex soap	Calcium complex soap	Bentone	Urea compounds	Fluorine compounds	Thickener
Mineral oil	Mineral oil	Mineral oil	Mineral/ synthetic oil	Synthetic oil	Base oil
250 or higher	200 to 280	–	240 or higher	250 or higher	Dropping point (°C)
– 30 to + 150	– 10 to + 130	– 10 to + 150	– 30 to + 150	– 40 to + 250	Operating temperature range (°C)
Low to high	Low to medium	Medium to high	Low to high	Low to medium	Rotation speed range
Good to excellent	Good	Good	Good to excellent	Good	Mechanical stability
Good to excellent	Good	Good	Good to excellent	Good	Water resistance
Good	Good	Good to excellent	Good to excellent	Good	Pressure resistance
Superior mechanical stability and heat resistance. Used at relatively high temperature.	Superior pressure resistance when extreme pressure agent is added. Used in bearings for rolling mills.	Suitable for applications at high temperature and under relatively heavy load.	Superior water resistance, oxidation stability, and heat stability. Suitable for applications at high temperature and high speed.	Superior chemical resistance and solvent resistance. Usable at up to 250 °C.	Remarks

12-2-2 Lubricating oil

For lubrication, bearings usually employ highly refined mineral oils, which have superior oxidation stability, rust-preventive effect, and high film strength.

With bearing diversification, however, various synthetic oils have been put into use.

These synthetic oils contain various additives (oxidation inhibitors, rust preventives, antifoaming agents, etc.) to improve specific properties. Table 12-5 shows the characteristics of lubricating oils.

Mineral lubricating oils are classified by applications in JIS and MIL.

Table 12-5 Characteristics of lubricating oils

Type of lubricating oil	Highly refined mineral oil	Major synthetic oils				
		Diester oil	Silicon oil	Polyglycolic oil	Polyphenyl ether oil	Fluorinated oil
Operating temperature range (°C)	- 40 to + 220	- 55 to + 150	- 70 to + 350	- 30 to + 150	0 to + 330	- 20 to + 300
Lubricity	Excellent	Excellent	Fair	Good	Good	Excellent
Oxidation stability	Good	Good	Fair	Fair	Excellent	Excellent
Radioactivity resistance	Bad	Bad	Bad to fair	Bad	Excellent	-

[Selection of lubricating oil]

The most important criterion in selecting a lubricating oil is whether the oil provides proper viscosity at the bearing operating temperature.

Standard values of proper kinematic viscosity can be obtained through selection by bearing type according to Table 12-6 first, then through selection by bearing operating conditions according to Table 12-7.

When lubricating oil viscosity is too low, the oil film will be insufficient. On the other hand, when the viscosity is too high, heat will be generated due to viscous resistance.

In general, the heavier the load and the higher the operating temperature, the higher the lubricating oil viscosity should be ; whereas, the higher the rotation speed, the lower the viscosity should be.

Fig. 12-3 illustrates the relationship between lubricating oil viscosity and temperature.

Table 12-6 Proper kinematic viscosity by bearing type

Bearing type	Proper kinematic viscosity at operating temperature
Ball bearing Cylindrical roller bearing	13mm ² / s or higher
Tapered roller bearing Spherical roller bearing	20mm ² / s or higher
Spherical thrust roller bearing	32mm ² / s or higher

Table 12-7 Proper kinematic viscosities by bearing operating conditions

Operating temperature	$d_m n$ value	Proper kinematic viscosity (expressed in the ISO viscosity grade or the SAE No.)		
		Light/normal load		Heavy/impact load
-30 to 0°C	All rotation speeds	ISO VG 15, 22, 46	(Refrigerating machine oil)	---
0 to 60°C	300 000 or lower	ISO VG 46	(Bearing oil Turbine oil)	ISO VG 68 SAE 30 (Bearing oil Turbine oil)
	300 000 to 600 000	ISO VG 32	(Bearing oil Turbine oil)	ISO VG 68 (Bearing oil Turbine oil)
	600 000 or higher	ISO VG 7, 10, 22	(Bearing oil)	---
60 to 100°C	300 000 or lower	ISO VG 68	(Bearing oil)	ISO VG 68, 100 SAE 30 (Bearing oil)
	300 000 to 600 000	ISO VG 32, 46	(Bearing oil Turbine oil)	ISO VG 68 (Bearing oil Turbine oil)
	600 000 or higher	ISO VG 22, 32, 46	(Bearing oil Turbine oil Machine oil)	---
100 to 150°C	300 000 or lower	ISO VG 68, 100 SAE 30, 40	(Bearing oil)	ISO VG 100 to 460 (Bearing oil Gear oil)
	300 000 to 600 000	ISO VG 68 SAE 30	(Bearing oil Turbine oil)	ISO VG 68, 100 SAE 30, 40 (Bearing oil)

[Remarks] 1. $d_m n = \frac{D+d}{2} \times n \dots$ { D : nominal outside diameter (mm), d : nominal bore diameter (mm),
 n : rotational speed (min^{-1}) }

2. Refer to refrigerating machine oil (JIS K 2211), turbine oil (JIS K 2213), gear oil (JIS K 2219), machine oil (JIS K 2238) and bearing oil (JIS K 2239).

3. Please contact with JTEKT if the bearing operating temperature is under -30°C or over 150°C .

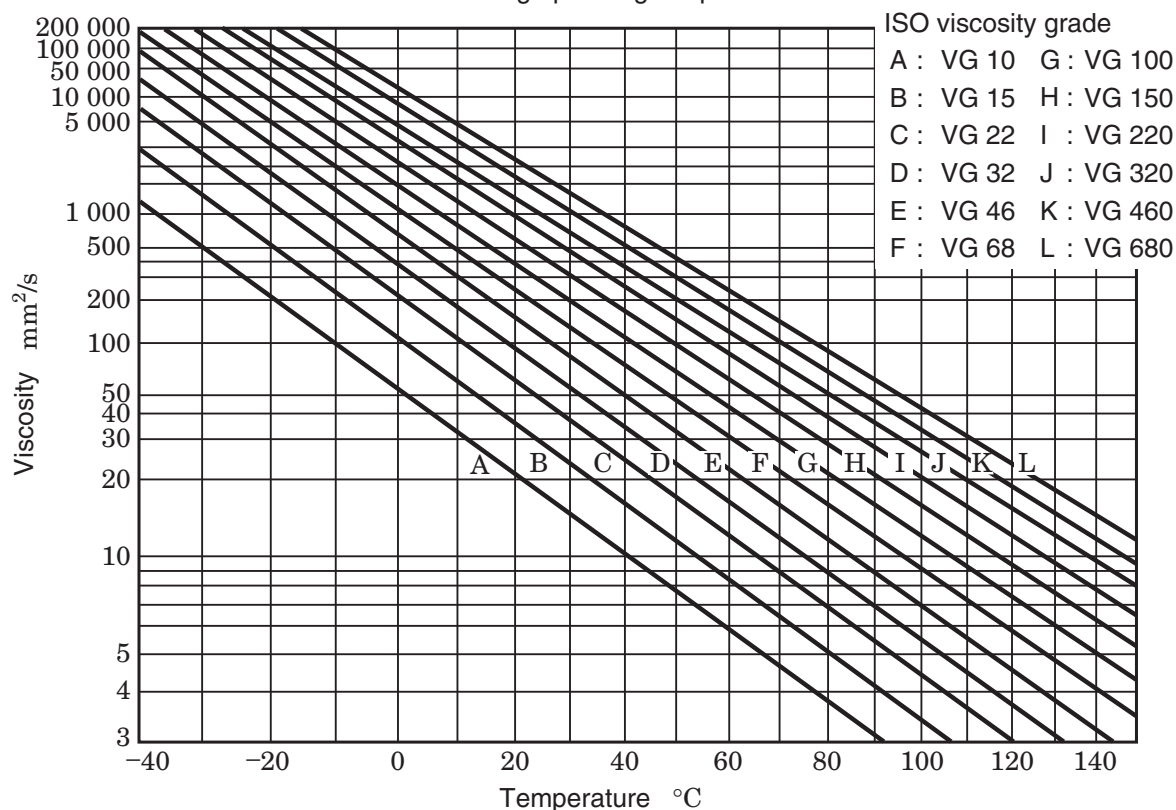

Fig. 12-3 Relationship between lubricating oil viscosity and temperature (viscosity index :100)

13. Bearing materials

Bearing materials include steel for bearing rings and rolling elements, as well as steel sheet, steel, copper alloy and synthetic resins for cages.

These bearing materials should possess the following characteristics :

- | | | |
|--|---|------------------|
| 1) High elasticity, durable under high partial contact stress. | } | Bearing rings |
| 2) High strength against rolling contact fatigue due to large repetitive contact load. | | |
| 3) Strong hardness | } | Rolling elements |
| 4) High abrasion resistance | | |
| 5) High toughness against impact load | } | Bearing rings |
| 6) Excellent dimensional stability | | |
| | | Rolling elements |
| | | Cages |

13-1 Bearing rings and rolling elements materials

1) High carbon chromium bearing steel

High carbon chromium bearing steel specified in JIS is used as a general material in bearing rings (inner rings, outer rings) and rolling elements (balls, rollers).

Their chemical composition classified by steel type is given in Table 13-1.

Among these steel types, SUJ 2 is generally used. SUJ 3, which contains additional Mn and Si, possesses high hardenability and is commonly used for thick section bearings.

SUJ 5 has increased hardenability, because it was developed by adding Mo to SUJ 3.

For small and medium size bearings, SUJ 2 and SUJ 3 are used, and for large size and extra-large size bearings with thick sections, SUJ 5 is widely used.

Generally, these materials are processed into the specified shape and then undergo hardening and annealing treatment until they attain a hardness of 57 to 64 HRC.

2) Case carburizing bearing steel (case hardened steel)

When a bearing receives heavy impact loads, the surface of the bearing should be hard and the inside soft.

Such materials should possess a proper amount of carbon, dense structure, and carburizing case depth on their surface, while having proper hardness and fine structure internally.

For this purpose, chromium steel and nickel-chromium-molybdenum steel are used as materials.

Typical steel materials are shown in Table 13-2.

These materials also undergo vacuum degassing in order to reduce non-metallic inclusions and oxygen content which leads to higher reliability.

3) Others

For special applications, the following materials are used, according to operational conditions.

(When very high reliability is required)

- high refining steel ... developed by JTEKT
- vacuum arc remelted steel
- electro slag remelted steel

(When heat resistance is required)

- high speed steel for high temperature bearings ... refer to Table 13-3

(When high corrosion resistance is required)

- stainless steel ... refer to Table 13-4

(When high heat, corrosion, and chemical resistance are required)

- ceramics

Table 13-1 Chemical composition of high carbon chromium bearing steel

Standard	Code	Chemical composition (%)						
		C	Si	Mn	P	S	Cr	Mo
JIS G 4805	SUJ 2	0.95 – 1.10	0.15 – 0.35	Not more than 0.50	Not more than 0.025	Not more than 0.025	1.30 – 1.60	Not more than 0.08
	SUJ 3	0.95 – 1.10	0.40 – 0.70	0.90 – 1.15			0.90 – 1.20	Not more than 0.08
	SUJ 5	0.95 – 1.10	0.40 – 0.70	0.90 – 1.15			0.90 – 1.20	0.10 – 0.25
SAE J 404	52100	0.98 – 1.10	0.15 – 0.35	0.25 – 0.45	Not more than 0.025	Not more than 0.025	1.30 – 1.60	Not more than 0.06

[Remark] As for bearings which are induction hardened, carbon steel with a high carbon content of 0.55 to 0.65 % is used in addition to those listed in this table.

Table 13-2 Chemical composition of case carburizing bearing steel

Standard	Code	Chemical composition (%)							
		C	Si	Mn	P	S	Ni	Cr	Mo
JIS G 4053	SCr 415	0.13 – 0.18	0.15 – 0.35	0.60 – 0.85	Not more than 0.030	Not more than 0.030	–	0.90 – 1.20	–
	SCr 420	0.18 – 0.23	0.15 – 0.35	0.60 – 0.85			–	0.90 – 1.20	–
	SCM 420	0.18 – 0.23	0.15 – 0.35	0.60 – 0.85	Not more than 0.030	Not more than 0.030	–	0.90 – 1.20	0.15 – 0.30
	SNCM 220	0.17 – 0.23	0.15 – 0.35	0.60 – 0.90	Not more than 0.030	Not more than 0.030	0.40 – 0.70	0.40 – 0.65	0.15 – 0.30
	SNCM 420	0.17 – 0.23	0.15 – 0.35	0.40 – 0.70			1.60 – 2.00	0.40 – 0.65	0.15 – 0.30
	SNCM 815	0.12 – 0.18	0.15 – 0.35	0.30 – 0.60	Not more than 0.030	Not more than 0.030	4.00 – 4.50	0.70 – 1.00	0.15 – 0.30
SAE J 404	5120	0.17 – 0.22	0.15 – 0.35	0.70 – 0.90	Not more than 0.035	Not more than 0.040	–	0.70 – 0.90	–
	8620	0.18 – 0.23	0.15 – 0.35	0.70 – 0.90	Not more than 0.035	Not more than 0.040	0.40 – 0.70	0.40 – 0.60	0.15 – 0.25
	4320	0.17 – 0.22	0.15 – 0.30	0.45 – 0.65	Not more than 0.025	Not more than 0.025	1.65 – 2.00	0.40 – 0.60	0.20 – 0.30

Table 13-3 Chemical composition of high speed steel for high temperature bearings

Standard	Code	Chemical composition (%)											
		C	Si	Mn	P	S	Cr	Mo	V	Ni	Cu	Co	W
AISI	M 50	0.77 – 0.85	Not more than 0.25	Not more than 0.35	Not more than 0.015	Not more than 0.015	3.75 – 4.25	4.00 – 4.50	0.90 – 1.10	Not more than 0.10	Not more than 0.10	Not more than 0.25	Not more than 0.25

Table 13-4 Chemical composition of stainless steel

Standard	Code	Chemical composition (%)						
		C	Si	Mn	P	S	Cr	Mo
JIS G 4303	SUS 440 C	0.95 – 1.20	Not more than 1.00	Not more than 1.00	Not more than 0.040	Not more than 0.030	16.00 – 18.00	Not more than 0.75

13-2 Materials used for cages

Since the characteristics of materials used for cages greatly influence the performance and reliability of rolling bearings, the choice of materials is of great importance.

It is necessary to select cage materials in accordance with required shape, ease of lubrication, strength, and abrasion resistance.

Typical materials used for metallic cages are shown in Tables 13-5 and 13-6.

In addition, phenolic resin machined cages and other synthetic resin molded cages are often used.

Materials typically used for molded cages are polyacetal, polyamide (Nylon 6.6, Nylon 4.6), and polymer containing fluorine, which are strengthened with glass and carbon fibers.

Table 13-5 Chemical compositions of pressed cage steel sheet (A) and machined cage carbon steel (B)

	Standard	Code	Chemical composition (%)						
			C	Si	Mn	P	S	Ni	Cr
(A)	JIS G 3141	SPCC	Not more than 0.12	–	Not more than 0.50	Not more than 0.040	Not more than 0.045	–	–
	JIS G 3131	SPHC	Not more than 0.15	–	Not more than 0.60	Not more than 0.050	Not more than 0.050	–	–
	BAS 361	SPB 2	0.13 – 0.20	Not more than 0.04	0.25 – 0.60	Not more than 0.030	Not more than 0.030	–	–
	JIS G 4305	SUS 304	Not more than 0.08	Not more than 1.00	Not more than 2.00	Not more than 0.045	Not more than 0.030	8.00 – 10.50	18.00 – 20.00
(B)	JIS G 4051	S 25 C	0.22 – 0.28	0.15 – 0.35	0.30 – 0.60	Not more than 0.030	Not more than 0.035	–	–

Table 13-6 Chemical composition of high-tensile brass casting of machined cages (%)

Standard	Code	Cu	Zn	Mn	Fe	Al	Sn	Ni	Pb	Si
JIS H 5120	CAC 301 (HBsC*)	55 – 60	33 – 42	0.1 – 0.5	0.5 – 1.5	0.5 – 1.5	Not more than 1.0	Not more than 1.0	Not more than 0.4	Not more than 0.1

* : Material with HBsC is used.

14. Shaft and housing design

In designing the shaft and housing, the following should be taken into consideration.

- 1) Shafts should be thick and short.
(in order to reduce distortion including bending)
- 2) Housings should possess sufficient rigidity.
(in order to reduce distortion caused by load)
[Note] · For light alloy housings, rigidity may be provided by inserting a steel bushing.

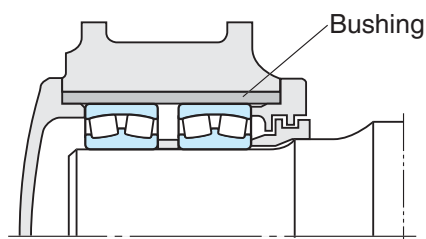

Fig. 14-1 Example of light alloy housing

- 3) The fitting surface of the shaft and housing should be finished in order to acquire the required accuracy and roughness. The shoulder end-face should be finished in order to be perpendicular to the shaft center or housing bore surface. (refer to Table 14-1)
- 4) The fillet radius (r_a) should be smaller than chamfer dimension of the bearing.
(refer to Tables 14-2, 14-3)
[Notes] · Generally it should be finished so as to form a simple circular arc.
(refer to Fig. 14-2)
· When the shaft is given a ground finish, a recess may be provided.
(Fig. 14-3)

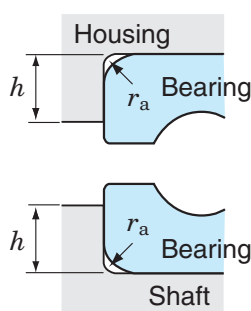

Fig. 14-2 Fillet radius

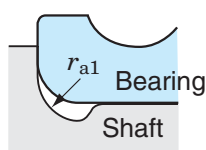

Fig. 14-3 Grinding undercut

- 5) The shoulder height (h) should be smaller than the outside diameter of inner ring and larger than bore diameter of outer ring so that the bearing is easily dismantled.
(refer to Fig. 14-2 and Table 14-2)
- 6) If the fillet radius must be larger than the bearing chamfer, or if the shaft/housing shoulder must be low/high, insert a spacer as shown in Fig. 14-4, or between the outer ring and the housing shoulder.

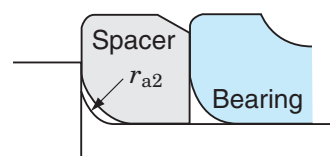

Fig. 14-4 Example of shaft with spacer

- 7) Screw threads and lock nuts should be completely perpendicular to shaft axis. It is desirable that the tightening direction of threads and lock nuts be opposite to the shaft rotating direction.
- 8) When split housings are used, the surfaces where the housings meet should be finished smoothly and provided with a recess at the inner ends of the surfaces that meet.

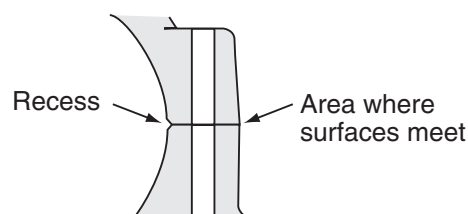

Fig. 14-5 Recesses on meeting surfaces

14-1 Accuracy and roughness of shafts and housings

The fitting surface of the shaft and housing may be finished by turning or fine boring when the bearing is used under general operating conditions. However, if the conditions require minimum vibration and noise, or if the bearing is used under severe operating conditions, a ground finish is required.

Recommended accuracy and roughness of shafts and housings under general conditions are given in Table 14-1.

Table 14-1 Recommended accuracy and roughness of shafts and housings

Item	Bearing class	Shaft	Housing bore
Roundness tolerance	classes 0, 6	IT 3 – IT 4	IT 4 – IT 5
	classes 5, 4	IT 2 – IT 3	IT 2 – IT 3
Cylindrical form tolerance	classes 0, 6	IT 3 – IT 4	IT 4 – IT 5
	classes 5, 4	IT 2 – IT 3	IT 2 – IT 3
Shoulder runout tolerance	classes 0, 6	IT 3	IT 3 – IT 4
	classes 5, 4	IT 3	IT 3
Roughness of fitting surfaces Ra	Small size bearings	0.8 a	1.6 a
	Large size bearings	1.6 a	3.2 a

[Remark] Refer to the figures listed in the attached table when the basic tolerance IT is required.

14-2 Mounting dimensions

Mounting dimensions mean the necessary dimensions to mount bearings on shafts or housings, which include the fillet radius or shoulder diameters.

Standard values are shown in Table 14-2. (The mounting related dimensions of each bearing are given in the bearing specification table.)

The grinding undercut dimensions for ground shafts are given in Table 14-3.

Table 14-2 Shaft/housing fillet radius and shoulder height of radial bearings

Unit : mm

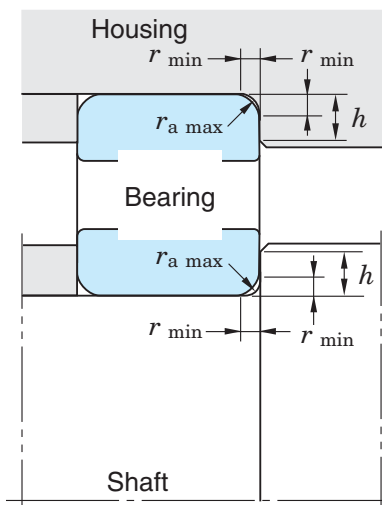

[Notes]

- 1) Shoulder heights greater than those specified in the Table are required to accommodate heavy axial loads.
- 2) Used when an axial load is small. These values are not recommended for tapered roller bearings, angular contact ball bearings, or spherical roller bearings.

[Remark]

Fillet radius can be applied to thrust bearings.

Chamfer dimension of inner ring or outer ring r_{min}	Shaft and housing		
	Fillet radius $r_{a\ max}$	Shoulder height h_{min}	
		General cases ¹⁾	Special cases ²⁾
0.05	0.05	0.3	0.3
0.08	0.08	0.3	0.3
0.1	0.1	0.4	0.4
0.15	0.15	0.6	0.6
0.2	0.2	0.8	0.8
0.3	0.3	1.25	1
0.5	0.5	1.75	1.5
0.6	0.6	2.25	2
0.8	0.8	2.75	2.5
1	1	2.75	2.5
1.1	1	3.5	3.25
1.5	1.5	4.25	4
2	2	5	4.5
2.1	2	6	5.5
2.5	2	6	5.5
3	2.5	7	6.5
4	3	9	8
5	4	11	10
6	5	14	12
7.5	6	18	16
9.5	8	22	20
12	10	27	24
15	12	32	29
19	15	42	38

For thrust bearings, the mounting dimensions should be carefully determined such that bearing race will be perpendicular to the support and the supporting area will be wide enough.

For thrust ball bearings, the shaft shoulder diameter d_a should be larger than pitch diameter of ball set, while the shoulder diameter of housing D_a should be smaller than the pitch diameter of ball set. (Fig. 14-6)

For thrust roller bearings, the housing/shaft diameter D_a/d_a should cover the lengths of both rollers. (Fig. 14-7)

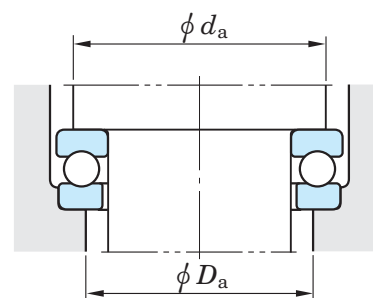

Fig. 14-6 Thrust ball bearings

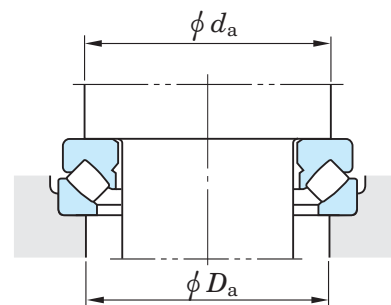
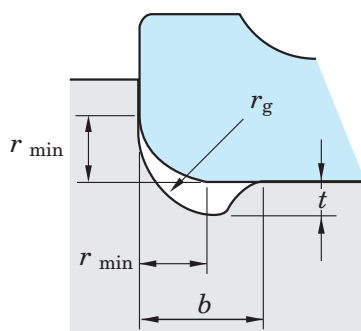

Fig. 14-7 Spherical thrust roller bearings

Table 14-3 Grinding undercut dimensions for ground shafts



Unit : mm

Chamfer dimension of inner ring r_{min}	Grinding undercut dimensions		
	t	r_g	b
1	0.2	1.3	2
1.1	0.3	1.5	2.4
1.5	0.4	2	3.2
2	0.5	2.5	4
2.1	0.5	2.5	4
3	0.5	3	4.7
4	0.5	4	5.9
5	0.6	5	7.4
6	0.6	6	8.6
7.5	0.6	7	10

14-3 Shaft design

When bearings are mounted on shafts, locating method should be carefully determined. Shaft design examples for cylindrical bore bearings are given in Table 14-4, and those for bearings with a tapered bore in Table 14-5.

Table 14-4 Mounting designs for cylindrical bore bearings

(a) Shaft locknut	(b) End plate	(c) Locating snap ring
		
<p>Lockwashers are used to prevent loosening of locknuts. When tapered roller bearings or angular contact ball bearings are transition-fitted to shafts, plain washers several mm thick as shown above (at right) should be added and tightened with nut.</p>	<p>End of shaft should have bolt holes.</p>	<p>Used when the housing inside is limited, or to simplify shaft machining.</p>

Table 14-5 Mounting designs for bearings with tapered bore

(d) Adapter assembly	(e) Withdrawal sleeve	(f) Shaft locknut	(g) Split ring
			
<p>The simplest method for axial positioning is just to attach an adapter sleeve to the shaft and tighten the locknuts. To prevent locknut loosening, lock-washer (not more than 180 mm in shaft diameter) or lock plate (not less than 200 mm in shaft diameter) are used.</p>	<p>The locknut (above) or end plate (below) fixes the bearing with a withdrawal sleeve, which makes it easy to dismount the bearing.</p>	<p>The shaft is threaded in the same way as shown in Fig. (a). The bearing is located by tightening locknut.</p>	<p>A split ring with threaded outside diameter is inserted into groove on the tapered shaft. A key is often used to prevent the locknut and split ring from loosening.</p>

14-4 Sealing devices

Sealing devices not only prevent foreign matter (dirt, water, metal powder) from entering, but prevent lubricant inside from leaking. If the sealing device fails to function satisfactorily, foreign matter or leakage will cause bearing damage as a result of malfunction or seizure.

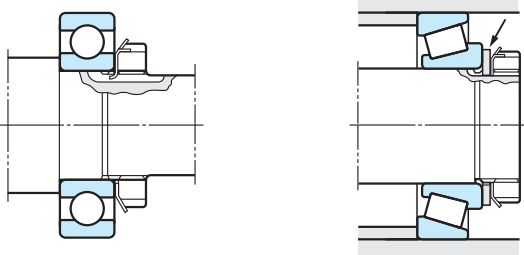
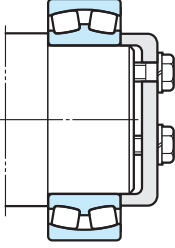
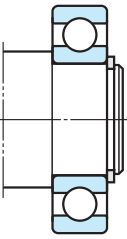
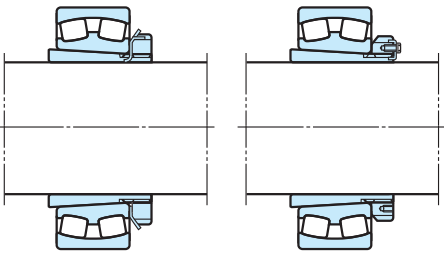
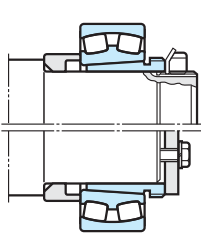
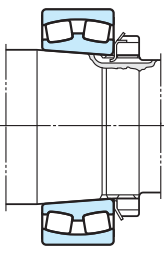
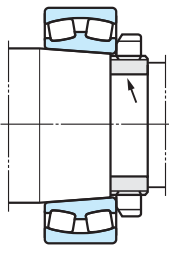
Therefore, it is necessary to design or choose the most suitable sealing devices as well as to choose the proper lubricating measures according to operating conditions.

Sealing devices may be divided into non-contact and contact types according to their structure.

They should satisfy the following conditions :

- Free from excessive friction
(heat generation)
- Easy maintenance (especially ease of mounting and dismounting)
- As low cost as possible

14-4-1 Non-contact type sealing devices

A non-contact type sealing device, which includes oil groove, flinger (slinger), and labyrinth, eliminates friction because it does not have a contact point with the shaft.

These devices utilize narrow clearance and centrifugal force and are especially suitable for operation at high rotation speed and high temperature.

Table 14-6 (1) Non-contact type sealing devices

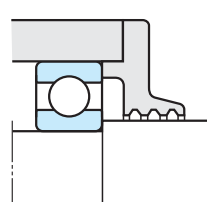
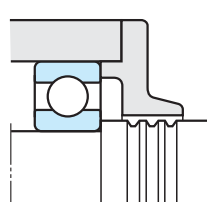
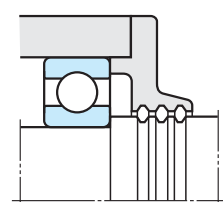
(1) Oil groove	
 <p>(a)</p>	 <p>(b)</p>
 <p>(c)</p>	

- This kind of seal having more than three grooves at the narrow clearance between the shaft and housing cover, is usually accompanied by other sealing devices except when it is used with grease lubrication at low rotation speed.
- Preventing entrance of contaminants can be improved by filling the groove with calcium grease (cup grease) having a consistency of 150 to 200.
- The clearance between the shaft and housing cover should be as narrow as possible. Recommended clearances are as follows.
 - Shaft diameter of less than 50mm
..... 0.25 – 0.4mm
 - Shaft diameter of over 50mm
..... 0.5 – 1 mm
- Recommended dimensions for the oil groove are as follows.
 - Width 2 – 5mm
 - Depth 4 – 5mm

Table 14-6 (2) Non-contact type sealing devices

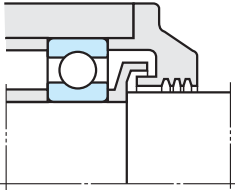
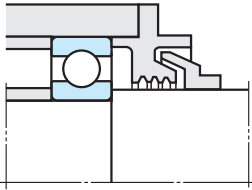
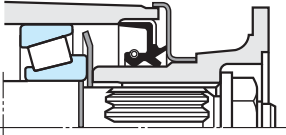
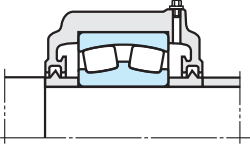
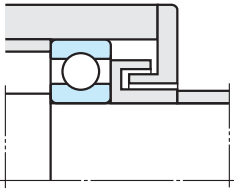
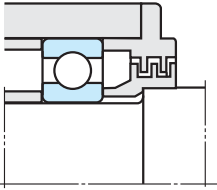
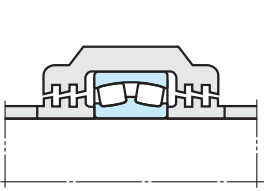
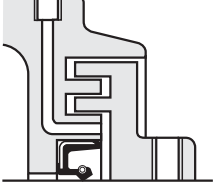
(2) Flinger (slinger)	(3) Labyrinth									
<div style="display: flex; justify-content: space-around;"> <div style="text-align: center;">  <p>(d) Flinger attached inside</p> </div> <div style="text-align: center;">  <p>(e) Flinger attached outside</p> </div> </div> <div style="display: flex; justify-content: space-around; margin-top: 20px;"> <div style="text-align: center;">  <p>(f) Cover type flinger</p> </div> <div style="text-align: center;">  <p>(g) Oil thrower</p> </div> </div>	<div style="display: flex; justify-content: space-around;"> <div style="text-align: center;">  <p>(h) Axial labyrinth</p> </div> <div style="text-align: center;">  <p>(i) Radial labyrinth</p> </div> </div> <div style="display: flex; justify-content: space-around; margin-top: 20px;"> <div style="text-align: center;">  <p>(j) Aligning labyrinth</p> </div> <div style="text-align: center;">  <p>(k) Axial labyrinth with greasing feature</p> </div> </div>									
<ul style="list-style-type: none"> ■ A flinger utilizes centrifugal force to splash away the oil and dirt. It produces an air stream which prevents oil leakage and dirt by a pumping action. In many cases, this device is used together with other sealing devices. ■ A flinger installed inside the housing (Fig. d) provides an inward pumping action, preventing lubricant leakage; and, when installed outside (Fig. e), the outward pumping action prevents lubricant contamination. ■ A cover type flinger (Fig. f) splashes away dirt and dust by centrifugal force. ■ The oil thrower, shown in (Fig. g), is a kind of flinger. An annular ridge on the shaft or a ring fitted onto the shaft utilizes centrifugal force to prevent the lubricant from flowing out. 	<ul style="list-style-type: none"> ■ A labyrinth provides clearance in the shape of engagements between the shaft and housing. It is the most suitable for prevention of lubricant leakage at high rotation speed. ■ Though an axial labyrinth, shown in (Fig. h), is popular because of its ease of mounting, the sealing effect is better in a radial labyrinth, shown in (Fig. i). ■ An aligning labyrinth (Fig. j) is used with self-aligning type bearings. ■ In the cases of (Fig. i) and (Fig. j), the housing or the housing cover should be split. ■ Recommended labyrinth clearances are given in the following table. <table border="1" style="width: 100%; border-collapse: collapse; text-align: center;"> <thead> <tr> <th style="padding: 5px;">Shaft diameter</th> <th style="padding: 5px;">Radial clearance</th> <th style="padding: 5px;">Axial clearance</th> </tr> </thead> <tbody> <tr> <td style="padding: 5px;">50mm or less</td> <td style="padding: 5px;">0.25 – 0.4mm</td> <td style="padding: 5px;">1 – 2mm</td> </tr> <tr> <td style="padding: 5px;">Over 50mm</td> <td style="padding: 5px;">0.5 – 1 mm</td> <td style="padding: 5px;">3 – 5mm</td> </tr> </tbody> </table> <ul style="list-style-type: none"> ■ To improve sealing effect, fill the labyrinth clearance with grease, shown in (Fig. k). 	Shaft diameter	Radial clearance	Axial clearance	50mm or less	0.25 – 0.4mm	1 – 2mm	Over 50mm	0.5 – 1 mm	3 – 5mm
Shaft diameter	Radial clearance	Axial clearance								
50mm or less	0.25 – 0.4mm	1 – 2mm								
Over 50mm	0.5 – 1 mm	3 – 5mm								

14-4-2 Contact type sealing devices

This type provides a sealing effect by means of the contact of its end with the shaft and are manufactured from synthetic rubber, synthetic resin, or felt.

The synthetic rubber oil seal is most popular.

1) Oil seals

Many types and sizes of oil seals, as a finished part, have been standardized.

JTEKT produces various oil seals.

The names and functions of each oil seal part are shown in Fig. 14-8 and Table 14-7. Table 14-8 provides a representative example.

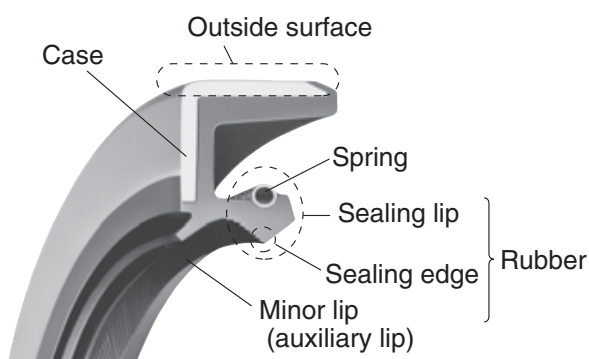

Fig. 14-8 Names of oil seal parts

Table 14-7 Complete list of oil seal part functions

Names	Functions
Sealing edge	Prevents fluid leakage by making contact with rotating shaft. (The contact surface of the sealing edge with the shaft should always be filled with lubricant, so as to maintain an oil film therein.)
Sealing lip and spring	Provides proper pressure on the sealing edge to maintain stable contact. Spring provides proper pressure on the lip and maintains such pressure for a long time.
Outside surface	Fixes the oil seal to the housing and prevents fluid leakage through the fitting surface. (Comes encased in metal cased type or rubber covered type.)
Case	Strengthens seal.
Minor lip (auxiliary lip)	Prevents entry of contaminants. (In many cases, the space between the sealing lip and minor lip is filled with grease.)

Table 14-8 Typical oil seal types

With case		With inner case	Without case
Without spring	With spring		With spring
 HM (JIS GM) MH (JIS G)	 HMS (JIS SM) MHS (JIS S) CRS	 HMSH (JIS SA)	 MS
 HMA MHA	 HMSA (JIS DM) MHSA (JIS D) CRSA	 HMSAH (JIS DA)	—

- The oil seals shown in the lower row contain the minor lip (auxiliary lip).
- Special types of seals such as the mud resistance seal, pressure resistance seal and outer seal for rotating housings can be provided to serve under various operating conditions.

- By providing a slit on the oil seals, it is possible to attach them from other points than the shaft ends.

Oil seals without minor lips are mounted in different directions according to their operating conditions (shown in Fig. 14-9).

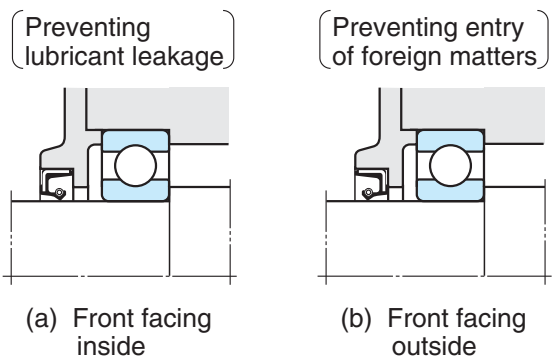

Fig. 14-9 Direction of sealing lips and their purpose

When the seal is used in a dirty operating environment, or penetration of water is expected, it is advisable to have two oil seals combined or to have the space between the two sealing lips be filled with grease.

(shown in Fig. 14-10)

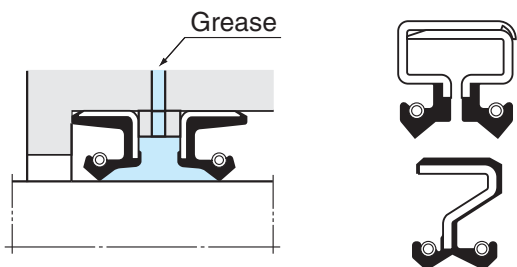

Fig. 14-10 Seals used in a dirty operating environment

Respective seal materials possess different properties. Accordingly, as shown in Table 14-9, allowable lip speed and operating temperature differ depending on the materials. Therefore, by selecting proper materials, oil seals can be used for sealing not only lubricants but also chemicals including alcohol, acids, alkali, etc.

Table 14-9 Allowable lip speed and operating temperature range of oil seals

Seal material	Allowable lip speed (m/s)	Operating temperature range (°C)
NBR	15	- 40 to + 120
Acrylic rubber	25	- 30 to + 150
Silicone rubber	32	- 50 to + 170
Fluoro rubber	32	- 20 to + 180

To ensure the maximum sealing effect of the oil seal, the shaft materials, surface roughness and hardness should be carefully chosen.

Table 14-10 shows the recommended shaft conditions.

Table 14-10 Recommended shaft conditions

Material	Machine structure steel, low alloy steel and stainless steel
Surface hardness	For low speed : harder than 30 HRC For high speed : harder than 50 HRC
Surface roughness (Ra)	0.2 – 0.6a A surface which is excessively rough may cause oil leakage or abrasion ; whereas an excessively fine surface may cause sealing lip seizure, preventing the oil film from forming. Surface must also be free of spiral grinding marks.

2) Felt seals and others

Although felt seals have been used conventionally, it is recommended to replace them with rubber oil seals because the use of felt seals are limited to the following conditions.

- Light dust protection
- Allowable lip speed : not higher than 5m/s

Contact type sealing devices include mechanical seals, O-rings and packings other than those described herein.

JTEKT manufactures various oil seals ranging from those illustrated in Table 14-8 to special seals for automobiles, large seals for rolling mills, mud resistance seals, pressure resistance seals, outer seals for rotating housings and O-rings. For details, refer to JTEKT separate catalog "Oil seals & O-rings" (CAT. NO. R2001E).

15. Handling of bearings

15-1 General instructions

Since rolling bearings are more precisely made than other machine parts, careful handling is absolutely necessary.

1) Keep bearings and the operating environment clean.

2) Handle carefully.

Bearings can be cracked and brinelled easily by strong impact if handled roughly.

3) Handle using the proper tools.

4) Keep bearings well protected from rust.

Do not handle bearings in high humidity.

Operators should wear gloves in order not to soil bearings with perspiration from their hands.

5) Bearings should be handled by experienced or well trained operators.

6) Set bearing operation standards and follow them.

- Storage of bearings
- Cleaning of bearings and their adjoining parts.
- Inspection of dimensions of adjoining parts and finish conditions
- Mounting
- Inspection after mounting
- Dismounting
- Maintenance and inspection (periodical inspection)
- Replenishment of lubricants

15-2 Storage of bearings

In shipping bearings, since they are covered with proper anti-corrosion oil and are wrapped in antitarnish paper, the quality of the bearings is guaranteed as long as the wrapping paper is not damaged.

If bearings are to be stored for a long time, it is advisable that the bearings be stored on shelves set higher than 30 cm from the floor, at a humidity less than 65 %, and at a temperature around 20°C.

Avoid storage in places exposed directly to the sun's rays or placing boxes of bearings against cold walls.

15-3 Bearing mounting

15-3-1 Recommended preparation prior to mounting

1) Preparation of bearings

Wait until just before mounting before removing the bearings from their packaging to prevent contamination and rust.

Since the anti-corrosion oil covering bearings is a highly capable lubricant, the oil should not be cleaned off if the bearings are pre-lubricated, or when the bearings are used for normal operation. However, if the bearings are used in measuring instruments or at high rotation speed, the anti-corrosion oil should be removed using a clean detergent oil. After removal of the anti-corrosion oil, bearings should not be left for a long time because they rust easily.

2) Inspection of shafts and housings

Clean up the shaft and housing to check whether it has flaws or burrs as a result of machining.

Be very careful to completely remove lapping agents (SiC, Al₂O₃, etc.), casting sands, and chips from inside the housing.

Next, check that the dimensions, forms, and finish conditions of the shaft and the housing are accurate to those specified on the drawing.

The shaft diameter and housing bore diameter should be measured at the several points as shown in Figs. 15-1 and 15-2.

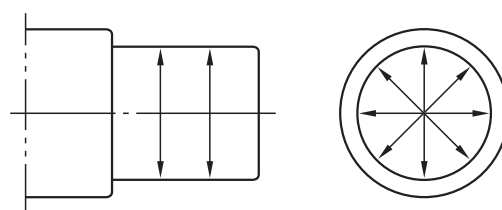

Fig. 15-1 Measuring points on shaft diameter

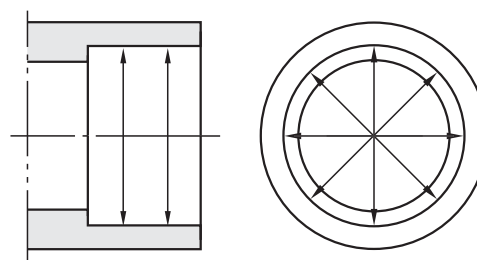

Fig. 15-2 Measuring points on housing bore diameter

Furthermore, fillet radius of shaft and housing, and the squareness of shoulders should be checked.

When using shaft and housing which have passed inspection, it is advisable to apply machine oil to each fitting surface just before mounting.

15-3-2 Bearing mounting

Mounting procedures depend on the type and fitting conditions of bearings.

For general bearings in which the shaft rotates, an interference fit is applied to inner rings, while a clearance fit is applied to outer rings.

For bearings in which the outer rings rotate, an interference fit is applied to the outer rings.

Interference fitting is roughly classified as shown here. The detailed mounting processes are described in Tables 15-1 to 15-3.

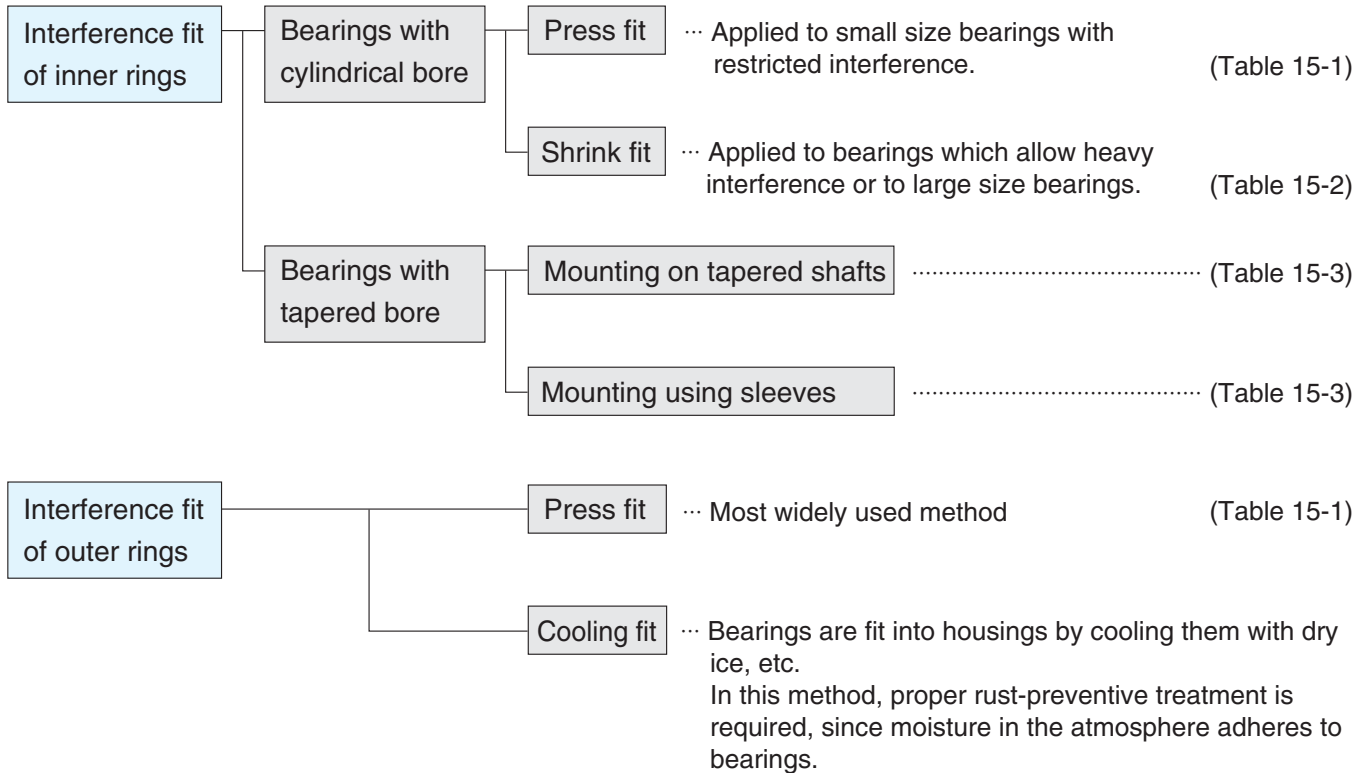

Reference Force is necessary to press fit or remove bearings.

The force necessary to press fit or remove inner rings of bearings differs depending on the finish of shafts and how much interference the bearings allow.

The standard values can be obtained by using the following equations.

(Solid shafts)
$$K_a = 9.8 f_k \cdot \Delta_{def} \cdot B \left(1 - \frac{d^2}{D_i^2} \right) \times 10^3 \dots\dots\dots (15-1)$$

(Hollow shafts)
$$K_a = 9.8 f_k \cdot \Delta_{def} \cdot B \frac{\left(1 - \frac{d^2}{D_i^2} \right) \left(1 - \frac{d_0^2}{d^2} \right)}{\left(1 - \frac{d_0^2}{D_i^2} \right)} \times 10^3 \dots\dots\dots (15-2)$$

Table 15-1 Press fit of bearings with cylindrical bores

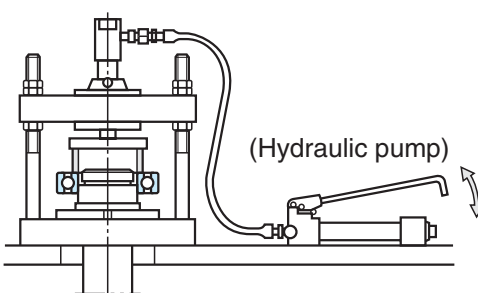
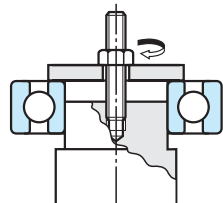
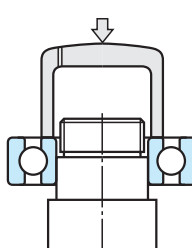
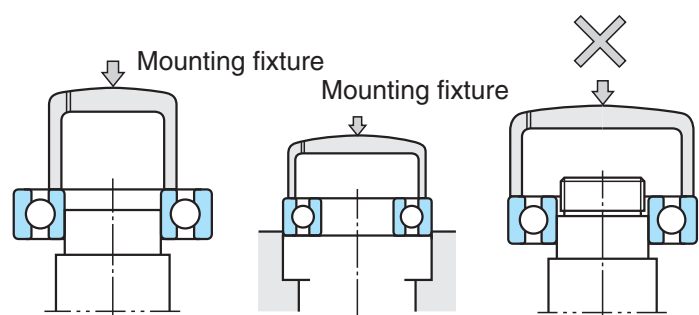
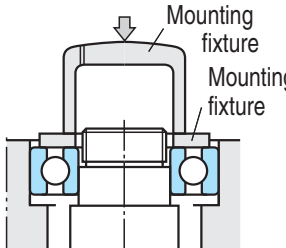
Mounting methods	Descriptions
<div style="display: flex; flex-direction: column; align-items: center;">  <p>(a) Using press fit (the most widely used method)</p> <div style="display: flex; justify-content: space-around; width: 100%;"> <div style="text-align: center;">  <p>(b) Using bolts and nuts (screw hole should be provided at the shaft end)</p> </div> <div style="text-align: center;">  <p>(c) Using hammers (only when there is no alternative measure)</p> </div> </div> </div>	<p>■ As shown in the Fig., a bearing should be mounted slowly with care, by using a fixture to apply force evenly to the bearing. When mounting the inner ring, apply pressure to the inner ring only. Similarly, in mounting the outer ring, press only the outer ring.</p> <div style="display: flex; justify-content: space-around; align-items: center;">  </div> <p>(Inner ring press fit) (Outer ring press fit) (Inner ring press fit)</p> <p>■ If interference is required on both the inner and outer ring of non-separable bearings, use two kinds of fixtures as shown in the Fig. and apply force carefully, as rolling elements are easily damaged. Be sure never to use a hammer in such cases.</p> <div style="text-align: center;">  <p>Simultaneous press fit of inner ring and outer ring</p> </div>



In equations (15-1) and (15-2),

- K_a : force necessary for press fit or removal N
- Δ_{deff} : effective interference mm
- f_k : resistance coefficient
- (Coefficient taking into consideration friction between shafts and inner rings ... refer to the table on the right)
- B : nominal inner ring width mm
- d : nominal inner ring bore diameter mm
- D_i : average outside diameter of inner ring mm
- d_0 : hollow shaft bore diameter mm

Value of resistance coefficient f_k

Conditions	f_k
• Press fitting bearings on to cylindrical shafts	4
• Removing bearings from cylindrical shafts	6
• Press fitting bearings on to tapered shafts or tapered sleeves	5.5
• Removing bearings from tapered shafts or tapered sleeves	4.5
• Press fitting tapered sleeves between shafts and bearings	10
• Removing tapered sleeves from the space between shafts and bearings	11

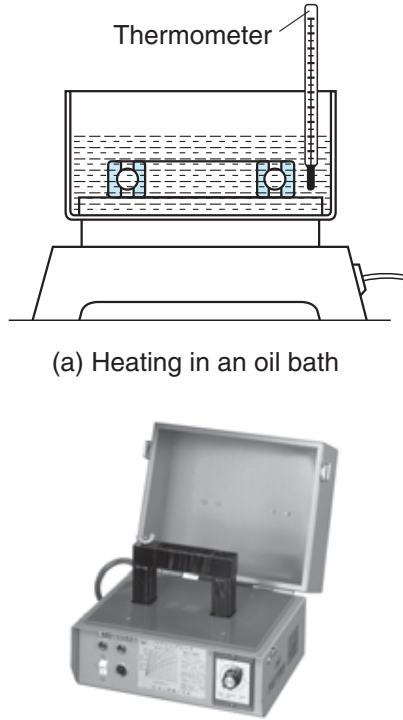
Table 15-2 Shrink fit of cylindrical bore bearings

Shrink fit	Descriptions
 <p>(a) Heating in an oil bath</p> <p>(b) Induction heater</p>	<p>■ This method, which expands bearings by heating them in oil, has the advantage of not applying too much force to bearings and taking only a short time.</p> <p>[Notes]</p> <ul style="list-style-type: none"> ● Oil temperature should not be higher than 100 °C, because bearings heated at higher than 120 °C lose hardness. ● Heating temperature can be determined from the bore diameter of a bearing and the interference by referring to Fig. 15-3. ● Use nets or a lifting device to prevent the bearing from resting directly on the bottom of the oil container. ● Since bearings shrink in the radial direction as well as the axial direction while cooling down, fix the inner ring and shaft shoulder tightly with the shaft nut before shrinking, so that no space is left between them. <p>■ Shrink fit proves to be clean and effective since, by this method, the ring can be provided with even heat in a short time using neither fire nor oil.</p> <p>(When electricity is being conducted, the bearing itself generates heat by its electrical resistance, aided by the built-in exciting coil.)</p> 

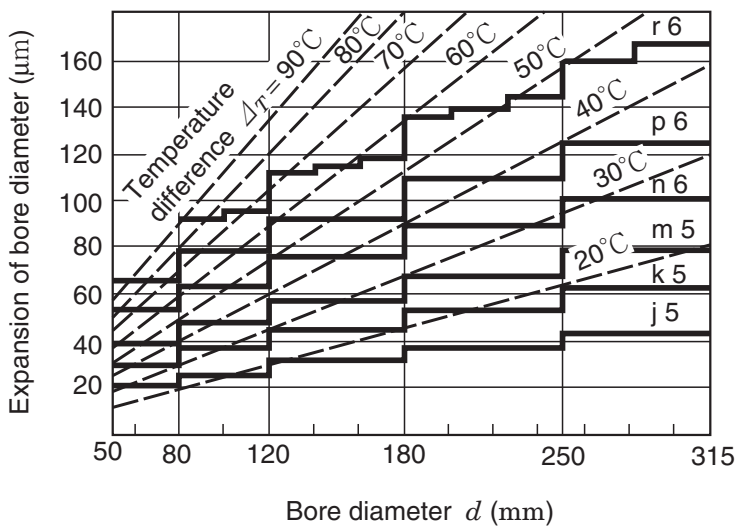

Fig. 15-3 Heating temperature and expansion of inner rings

[Remarks]

1. Thick solid lines show the maximum interference value between bearings (class 0) and shafts (r 6, p 6, n 6, m 5, k 5, j 5) at normal temperature.
2. Therefore, the heating temperature should be selected to gain a larger "expansion of the bore diameter" than the maximum interference values.

(When fitting class 0 bearings having a 90 mm bore diameter to m 5 shafts, this figure shows that heating temperature should be 40 °C higher than room temperature to produce expansion larger than the maximum interference value of 48 µm. However, taking cooling during mounting into consideration, the temperature should be set 20 to 30 °C higher than the temperature initially required.)

Table 15-3 Mounting bearings with tapered bores

Mounting methods	Descriptions
 <p>① Locknut ② Hydraulic nut</p> <p>(a) Mounting on tapered shafts</p>	<ul style="list-style-type: none"> ■ When mounting bearings directly on tapered shafts, provide oil holes and grooves on the shaft and inject high pressure oil into the space between the fitting surfaces (oil injection). Such oil injection can reduce tightening torque of locknut by lessening friction between the fitting surfaces. ■ When exact positioning is required in mounting a bearing on a shaft with no shoulder, use a clamp to help determine the position of the bearing.
 <p>① Locknut ② Hydraulic nut</p> <p>(b) Mounting by use of an adapter sleeve</p>	 <p>Locating bearing by use of a clamp</p> <ul style="list-style-type: none"> ■ When mounting bearings on shafts, locknuts are generally used. Special spanners are used to tighten them. Bearings can also be mounted using hydraulic nuts.
 <p>① Locknut ② Hydraulic nut</p> <p>(c) Mounting by use of a withdrawal sleeve</p>	 <p>special spanner</p> <ul style="list-style-type: none"> ■ When mounting tapered bore spherical roller bearings, the reduction in the radial internal clearance which gradually occurs during operation should be taken into consideration as well as the push-in depth described in Table 15-4.
 <p>(d) Measuring clearances</p>	<p>Clearance reduction can be measured by a thickness gage. First, stabilize the roller in the proper position and then insert the gage into the space between the rollers and the outer ring. Be careful that the clearance between both roller rows and the outer rings is roughly the same ($e \approx e'$). Since the clearance may differ at different measuring points, take measurements at several positions.</p> <ul style="list-style-type: none"> ■ When mounting self-aligning ball bearings, leave enough clearance to allow easy aligning of the outer ring.

Table 15-4 Mounting tapered bore spherical roller bearings

Nominal bore diameter d mm		Reduction of radial internal clearance μm		Axial displacement, mm				Minimum required residual clearance, μm		
				1/12 taper		1/30 taper		C N clearance	C 3 clearance	C 4 clearance
over	up to	min.	max.	min.	max.	min.	max.			
24	30	15	20	0.27	0.35	–	–	10	20	35
30	40	20	25	0.32	0.4	–	–	15	25	40
40	50	25	35	0.4	0.5	–	–	20	30	45
50	65	30	40	0.45	0.6	–	–	25	35	55
65	80	35	50	0.55	0.75	–	–	35	40	70
80	100	40	55	0.65	0.85	–	–	40	50	85
100	120	55	70	0.85	1.05	2.15	2.65	45	65	100
120	140	65	90	1.0	1.2	2.5	3.0	55	80	110
140	160	75	100	1.1	1.35	2.75	3.4	55	90	130
160	180	80	110	1.2	1.5	3.0	3.8	60	100	150
180	200	90	120	1.4	1.7	3.5	4.3	70	110	170
200	225	100	130	1.55	1.85	3.85	4.6	80	120	190
225	250	110	140	1.7	2.05	4.25	5.1	90	130	210
250	280	120	160	1.8	2.3	4.5	5.75	100	140	230
280	315	130	180	2.0	2.5	5.0	6.25	110	150	250
315	355	150	200	2.3	2.8	5.75	7.0	120	170	270
355	400	170	220	2.5	3.1	6.25	7.75	130	190	300
400	450	190	240	2.8	3.4	7.0	8.5	140	210	330
450	500	210	270	3.1	3.8	7.75	9.5	160	230	360
500	560	240	310	3.5	4.3	8.75	10.8	170	260	370
560	630	260	350	3.9	4.8	9.75	12.0	200	300	410
630	710	300	390	4.3	5.3	10.8	13.3	210	320	460
710	800	340	430	4.8	6.0	12.0	15.0	230	370	530
800	900	370	500	5.3	6.7	13.3	16.8	270	410	570
900	1000	410	550	5.9	7.4	14.8	18.5	300	450	640

[Remark] The values for reduction of radial internal clearance listed above are values obtained when mounting bearings with CN clearance on solid shafts. In mounting bearings with C 3 clearance, the maximum value listed above should be taken as the standard.

15-4 Test run

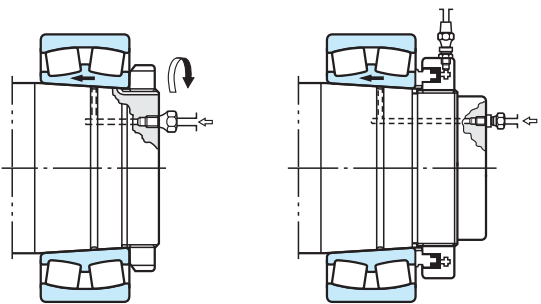
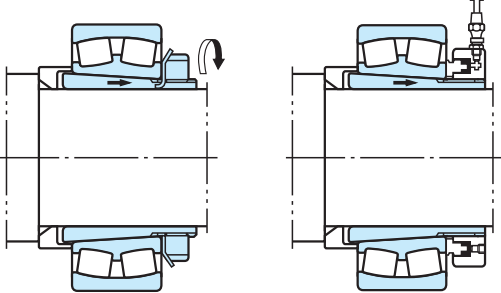
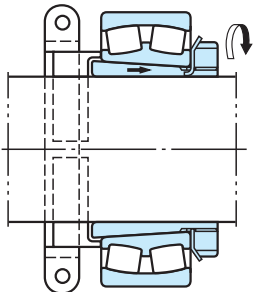
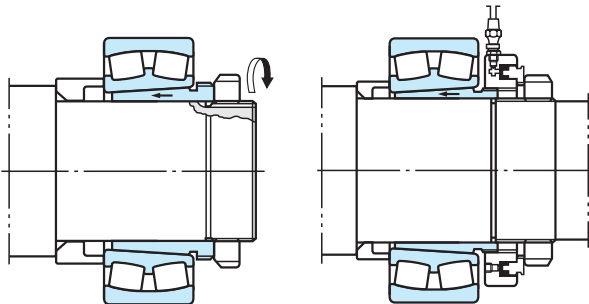
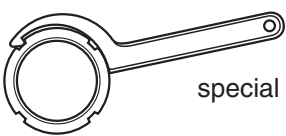
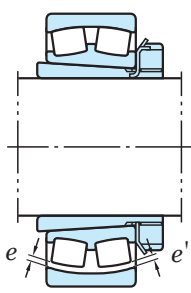
A trial operation is conducted to insure that the bearings are properly mounted.

In the case of compact machines, rotation may be checked by manual operation at first.

If no abnormalities, such as those described below, are observed, then further trial operation proceeds using a power source.

- Knocking ...
due to flaws or insertion of foreign matter on rolling contact surfaces.
- Excessive torque (heavy) ...
due to friction on sealing devices, too small clearances, and mounting errors.

- Uneven running torque ...
due to improper mounting and mounting errors.

For machines too large to allow manual operation, idle running is performed by turning off the power source immediately after turning it on. Before starting power operation, it must be confirmed that bearings rotate smoothly without any abnormal vibration and noise.

Power operation should be started under no load and at low speed, then the speed is gradually increased until the designed speed is reached.

During power operation, check the noise, increase in temperature and vibration.

If any of the abnormalities listed in Tables 15-5 and 15-6 are found, operation must be

stopped, and inspection for defects immediately conducted.

The bearings should be dismantled if necessary.

Table 15-5 Bearing noises, causes, and countermeasures

Noise types		Causes	Countermeasures
Cyclic	Flaw noise (similar to noise when punching a rivet) Rust noise Brinelling noise (Unclear siren-like noise)	Flaw on raceway Rust on raceway Brinelling on raceway	Improve mounting procedure, cleaning method and rust preventive method. Replace bearing.
	Flaking noise (similar to a large hammering noise)	Flaking on raceway	Replace bearing.
Not cyclic	Dirt noise (an irregular sandy noise.)	Insertion of foreign matter	Improve cleaning method, sealing device. Use clean lubricant. Replace bearing.
	Fitting noise (drumming or hammering noise)	Improper fitting or excessive bearing clearance	Review fitting and clearance conditions. Provide preload. Improve mounting accuracy.
	Flaw noise, rust noise, flaking noise	Flaws, rust and flaking on rolling elements	Replace bearing.
	Squeak noise (often heard in cylindrical roller bearings with grease lubrication, especially in winter or at low temperatures)	If noise is caused by improper lubrication, a proper lubricant should be selected. In general, however, serious damage will not be caused by an improper lubricant if used continuously.	
Others	Abnormally large metallic sound	Abnormal load Incorrect mounting Insufficient amount of or improper lubricant	Review fitting, clearance. Adjust preload. Improve accuracy in processing and mounting shafts and housings. Improve sealing device. Refill lubricant. Select proper lubricant.

Table 15-6 Causes and countermeasures for abnormal temperature rise

Causes	Countermeasures
Too much lubricant	Reduce lubricant amount. Use grease of lower consistency.
Insufficient lubricant	Refill lubricant.
Improper lubricant	Select proper lubricant.
Abnormal load	Review fitting and clearance conditions and adjust preload.
Improper mounting (excessive friction)	Improve accuracy in processing and mounting shaft and housing. Review fitting. Improve sealing device.

Normally, listening rods are employed for bearing noise inspections.

The instrument detecting abnormalities through sound vibration and the Diagnosis System utilizing acoustic emission for abnormality detection are also applicable.

In general, bearing temperature can be estimated from housing temperature, but the most accurate method is to measure the temperature of outer rings directly via lubrication holes.

Normally, bearing temperature begins to rise gradually when operation is just starting; and, unless the bearing has some abnormality, the temperature stabilizes within one or two hours.

Therefore, a rapid rise in temperature or unusually high temperature indicates some abnormality.

15-5 Bearing dismounting

After dismounting bearings, handling of the bearings and the various methods available for this should be considered.

If the bearing is to be disposed of, any simple method such as torch cutting can be employed. If the bearing is to be reused or checked for the causes of its failure, the same amount of care as in mounting should be taken in dismounting so as not to damage the bearing and other parts.

Since bearings with interference fits are easily damaged during dismounting, measures to prevent damage during dismounting must be incorporated into the design.

It is recommended that dismounting devices be designed and manufactured, if necessary.

It is useful for discovering the causes of failures when the conditions of bearings, including mounting direction and location, are recorded prior to dismounting.

Dismounting method

Tables 15-7 to 15-9 describe dismounting methods for interference fit bearings intended for reuse or for failure analysis.

The force necessary to remove bearings can be calculated using the equations given on page A 134.

Table 15-7 Dismounting of cylindrical bore bearings

Inner ring dismounting methods	Descriptions
 <p>(a) Dismounting by use of a press</p> <p>(b) Dismounting by use of special tools</p> <p>(c) Dismounting by use of special tools</p> <p>(d) Dismounting using induction heater</p>	<ul style="list-style-type: none"> ● Non-separable bearings should be treated carefully during dismounting so as to minimize external force, which affects their rolling elements. ● The easiest way to remove bearings is by using a press as shown in Fig. (a). It is recommended that the fixture be prepared so that the inner ring can receive the removal force. ● Figs. (b) and (c) show a dismounting method in which special tools are employed. In both cases, the jaws of the tool should firmly hold the side of the inner ring. ● Fig. (d) shows an example of removal by use of an induction heater : this method can be adapted to both mounting and dismounting of the inner rings of NU and NJ type cylindrical roller bearings. The heater can be used for heating and expanding inner rings in a short time.

Table 15-8 Dismounting tapered bore bearings

Inner ring dismantling methods	Descriptions
 <p>(a) Dismounting by use of a wedge</p>  <p>(b) Dismounting by use of oil pressure</p>	<ul style="list-style-type: none"> ● Fig. (a) shows the dismantling of an inner ring by means of driving wedges into notches at the back of the labyrinth. Fig. (b) shows dismantling by means of feeding high pressure oil to the fitting surfaces. In both cases, it is recommended that a stopper (ex. shaft nuts) be provided to prevent bearings from suddenly dropping out.
 <p>(c) Dismounting by use of clamps</p>  <p>(d) Dismounting by use of hydraulic nuts</p>	<ul style="list-style-type: none"> ● For bearings with an adapter sleeve, the following two methods are suitable. As shown in Fig. (c), fix bearings with clamps, loosen locknuts, then hammer off the adapter sleeve. This method is mainly used for small size bearings. Fig. (d) shows the method using hydraulic nuts.
 <p>(e) Dismounting by use of locknuts</p>  <p>(f) Dismounting by use of bolts</p>  <p>(g) Dismounting by use of hydraulic nuts</p>	<ul style="list-style-type: none"> ● Small size bearings with withdrawal sleeves can be removed by tightening locknuts as shown in Fig. (e). For large size bearings, provide several bolt holes on locknuts as shown in Fig. (f), and tighten bolts. The bearings can then be removed as easily as small size bearings. ● Fig. (g) shows the method using hydraulic nuts.

Table 15-9 Dismounting of outer rings

Outer ring dismantling methods	Description
 <p>(a) Notchs for dismantling</p>  <p>(b) Bolt holes and bolts for dismantling</p>	<ul style="list-style-type: none"> ● To dismount outer rings with interference fits, it is recommended that notches or bolt holes be provided on the shoulder of the housings.

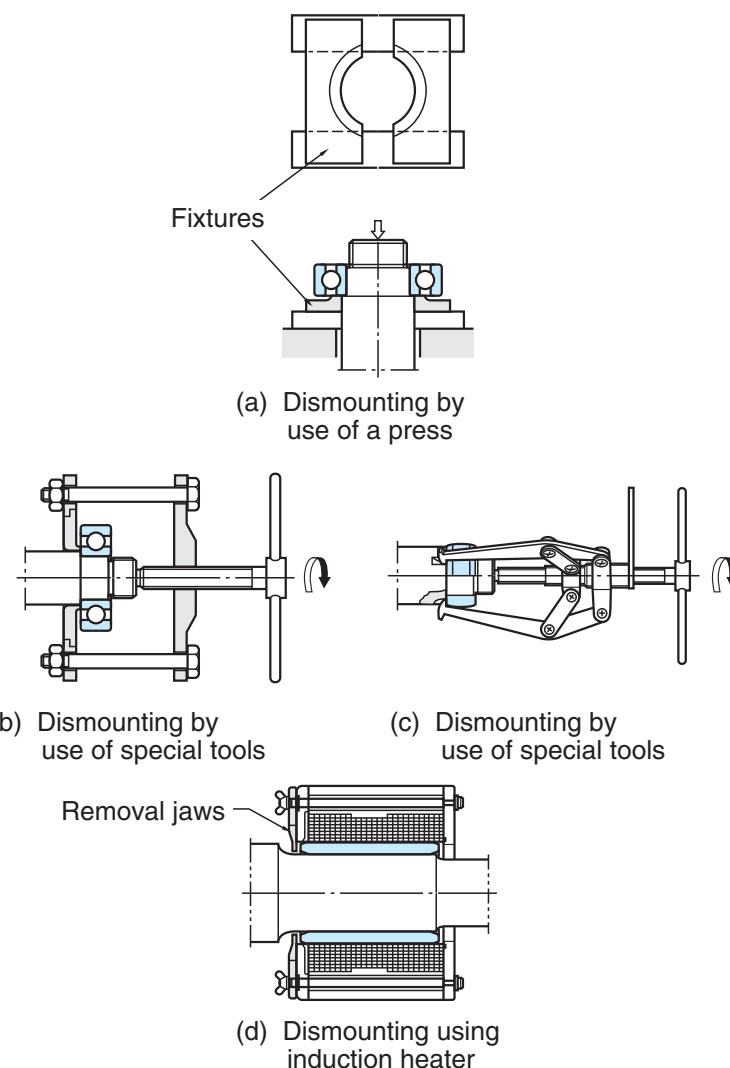
15-6 Maintenance and inspection of bearings

Periodic and thorough maintenance and inspection are indispensable to drawing full performance from bearings and lengthening their useful life.

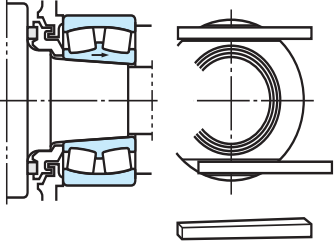
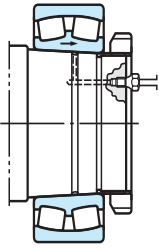
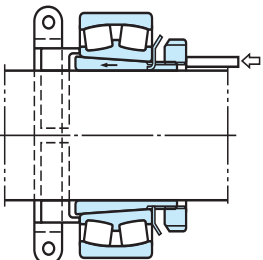
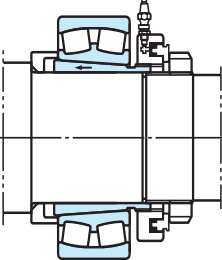
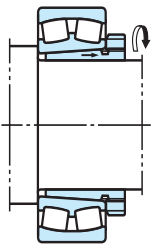
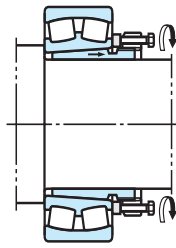
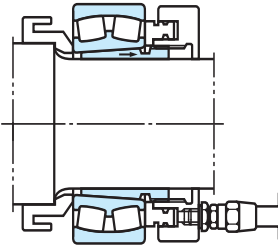
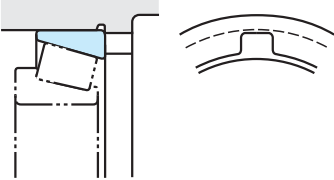
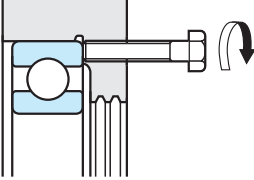
Besides, prevention of accidents and down time by early detection of failures through maintenance and inspection greatly contributes to the enhancement of productivity and profitability.

15-6-1 Cleaning

Before dismounting a bearing for inspection, record the physical condition of the bearing, including taking photographs.

Cleaning should be done after checking the amount of remaining lubricant and collecting lubricant as a sample for examination.

- A dirty bearing should be cleaned using two cleaning processes, such as rough cleaning and finish cleaning.

It is recommended that a net be set on the bottom of cleaning containers.

- In rough cleaning, use brushes to remove grease and dirt. Bearings should be handled carefully. Note that raceway surfaces may be damaged by foreign matter, if bearings are rotated in cleaning oil.
- During finish cleaning, clean bearings carefully by rotating them slowly in cleaning oil.

In general, neutral water-free light oil or kerosene is used to clean bearings, a warm alkali solution can also be used if necessary. In any case, it is essential to keep oil clean by filtering it prior to cleaning.

Apply anti-corrosion oil or rust preventive grease on bearings immediately after cleaning.

15-6-2 Inspection and analysis

Before determining that dismantled bearings will be reused, the accuracy of their dimensions and running, internal clearance, fitting surfaces, raceways, rolling contact surfaces, cages and seals must be carefully examined, so as to confirm that no abnormality is present.

It is desirable for skilled persons who have sufficient knowledge of bearings to make decisions on the reuse of bearings.

Criteria for reuse differs according to the performance and importance of machines and inspection frequency.

If the following defects are found, replace the bearing with a new one.

- Cracks and chips in bearing components
- Flaking on the raceway surfaces and the rolling contact surfaces
- Other failures of a serious degree described in the following section "16. Examples of bearing failures."

15-7 Methods of analyzing bearing failures

It is important for enhancing productivity and profitability, as well as for accident prevention that abnormalities in bearings are detected during operation.

Representative detection methods are described in the following section.

1) Noise checking

Since the detection of abnormalities in bearings from noises requires ample experience, sufficient training must be given to inspectors. Given this, it is recommended that specific persons be assigned to this work in order to gain this experience.

Attaching hearing aids or listening rods on housings is effective for detecting bearing noise.

2) Checking of operating temperature

Since this method utilizes change in operating temperature, its application is limited to relatively stable operations.

For detection, operating temperatures must be continuously recorded.

If abnormalities occur in bearings, operating temperature not only increase but also change irregularly.

It is recommended that this method be employed together with noise checking.





3) Lubricant checking

This method detects abnormalities from the foreign matter, including dirt and metallic powder, in lubricants collected as samples.

This method is recommended for inspection of bearings which cannot be checked by close visual inspection, and large size bearings.





16. Examples of bearing failures

Table 16-1 (1) Bearing failures, causes and countermeasures

Failures	Characteristics	
<p>1 Flaking</p>	 <p>(A-6961)</p> <p>Flaking is a phenomenon when material is removed in flakes from a surface layer of the bearing raceways or rolling elements due to rolling fatigue.</p> <p>This phenomenon is generally attributed to the approaching end of bearing service life. However, if flaking occurs at early stages of bearing service life, it is necessary to determine causes and adopt countermeasures.</p>	 <p>(A-6476)</p> <p>[Reference] Pitting</p> <p>Pitting is another type of failure caused by rolling fatigue, in which minute holes of approx. 0.1 mm in depth are generated on the raceway surface.</p>
<p>2 Cracking, chipping</p>	 <p>(A-6395)</p>	
<p>3 Brinelling, nicks</p>	 <p>(A-6617)</p> <p>(Brinelling)</p>	<ul style="list-style-type: none"> • Brinelling is a small surface indentation generated either on the raceway through plastic deformation at the contact point between the raceway and rolling elements, or on the rolling surfaces from insertion of foreign matter, when heavy load is applied while the bearing is stationary or rotating at a low rotation speed. • Nicks are those indentations produced directly by rough handling such as hammering.

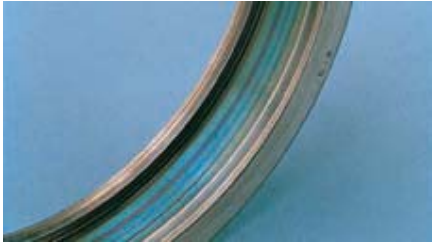



	Damages	Causes	Countermeasures
	Flaking occurring at an incipient stage	<ul style="list-style-type: none"> · Too small internal clearance · Improper or insufficient lubricant · Too much load · Rust 	<ul style="list-style-type: none"> · Provide proper internal clearance. · Select proper lubricating method or lubricant.
	Flaking on one side of radial bearing raceway	<ul style="list-style-type: none"> · Extraordinarily large axial load 	<ul style="list-style-type: none"> · Fitting between outer ring on the free side and housing should be changed to clearance fit.
	Symmetrical flaking along circumference of raceway	<ul style="list-style-type: none"> · Inaccurate housing roundness 	<ul style="list-style-type: none"> · Correct processing accuracy of housing bore. <p>(Especially for split housings, care should be taken to ensure processing accuracy.)</p>
	Slanted flaking on the radial ball bearing raceway	<ul style="list-style-type: none"> · Improper mounting · Shaft deflection · Inaccuracy of the shaft and housing 	<ul style="list-style-type: none"> · Correct centering. · Widen bearing internal clearance. · Correct squareness of shaft or housing shoulder.
	Flaking occurring near the edge of the raceway or rolling contact surface of roller bearings		
	Flaking on the raceway surface at the same interval as rolling element spacing	<ul style="list-style-type: none"> · Heavy impact load during mounting · A flaw of cylindrical roller bearings or tapered roller bearings caused when they are mounted. · Rust gathered while out of operation 	<ul style="list-style-type: none"> · Improve mounting procedure. · Provide rust prevention treatment before long cessation of operation.
	Cracking in outer ring or inner ring	<ul style="list-style-type: none"> · Excessive interference · Excessive fillet on shaft or housing · Heavy impact load · Advanced flaking or seizure 	<ul style="list-style-type: none"> · Select proper fit. · Adjust fillet on the shaft or in the housing to smaller than that of the bearing chamfer dimension. · Re-examine load conditions.
	Cracking on rolling elements	<ul style="list-style-type: none"> · Heavy impact load · Advanced flaking 	<ul style="list-style-type: none"> · Improve mounting and handling procedure. · Re-examine load conditions.
	Cracking on the rib	<ul style="list-style-type: none"> · Impact on rib during mounting · Excessive axial impact load 	<ul style="list-style-type: none"> · Improve mounting procedure. · Re-examine load conditions.
	Brinelling on the raceway or rolling contact surface	<ul style="list-style-type: none"> · Entry of foreign matter 	<ul style="list-style-type: none"> · Clean bearing and its peripheral parts. · Improve sealing devices.
	Brinelling on the raceway surface at the same interval as the rolling element spacing	<ul style="list-style-type: none"> · Impact load during mounting · Excessive load applied while bearing is stationary 	<ul style="list-style-type: none"> · Improve mounting procedure. · Improve machine handling.
	Nicks on the raceway or rolling contact surface	<ul style="list-style-type: none"> · Careless handling 	<ul style="list-style-type: none"> · Improve mounting and handling procedure.

Table 16-1 (2) Bearing failures, causes and countermeasures

Failures	Characteristics	
<p>4 Pear skin, discoloration</p>	 <p>(A-6720) (Discoloration)</p> <ul style="list-style-type: none"> • Pear skin is a phenomenon in which minute brinell marks cover the entire rolling surface, caused by the insertion of foreign matter. This is characterized by loss of luster and a rolling surface that is rough in appearance. In extreme cases, this is accompanied by discoloration due to heat generation. • Discoloration is a phenomenon in which the surface color changes because of staining or heat generation during rotation. Color change caused by rust and corrosion is generally separate from this phenomenon. 	
<p>5 Scratches, scuffing</p>	 <p>(A-6459) (Scuffing)</p> <ul style="list-style-type: none"> • Scratches are relatively shallow marks generated by sliding contact, in the same direction as the sliding. This is not accompanied by apparent melting of material. • Scuffing refers to marks, the surface of which are partially melted due to higher contact pressure and therefore a greater heat effect. • Generally, scuffing may be regarded as a serious case of scratches. 	
<p>6 Smearing</p>	 <p>(A-6640)</p> <p>Smearing is a phenomenon in which a cluster of minute seizures cover the rolling contact surface. Since smearing is caused by high temperature due to friction, the surface of the material usually melts partially ; and, the smeared surfaces appear very rough in many cases.</p>	
<p>7 Rust, corrosion</p>	 <p>(A-7130)</p> <ul style="list-style-type: none"> • Rust is a film of oxides, or hydroxides, or carbonates formed on a metal surface due to chemical reaction. • Corrosion is a phenomenon in which a metal surface is eroded by acid or alkali solutions through chemical reaction (electrochemical reaction such as chemical combination and battery formation) ; resulting in oxidation or dissolution. <ul style="list-style-type: none"> It often occurs when sulfur or chloride contained in the lubricant additives is dissolved at high temperature. 	
<p>8 Electric pitting</p>	 <p>(A-6652)</p> <p>When an electric current passes through a bearing while in operation, it can generate sparks between the raceway and rolling elements through a very thin oil film, resulting in melting of the surface metal in this area.</p> <p>This phenomenon appears to be pitting at first sight. (The resultant flaw is referred to as a pit.)</p> <p>When the pit is magnified, it appears as a hole like a crater, indicating that the material melted when it was sparking.</p> <p>In some cases, the rolling surface becomes corrugated by pitting.</p>	

	Damages	Causes	Countermeasures
	Indentation similar to pear skin on the raceway and rolling contact surface.	<ul style="list-style-type: none"> · Entry of minute foreign matter 	<ul style="list-style-type: none"> · Clean the bearing and its peripheral parts. · Improve sealing device.
	Discoloration of the raceway, surface rolling contact surface, rib face, and cage riding land.	<ul style="list-style-type: none"> · Too small bearing internal clearance · Improper or insufficient lubricant · Quality deterioration of lubricant due to aging, etc. 	<ul style="list-style-type: none"> · Provide proper internal clearance. · Select proper lubricating method or lubricant.
	Scratches on raceway or rolling contact surface	<ul style="list-style-type: none"> · Insufficient lubricant at initial operation · Careless handling 	<ul style="list-style-type: none"> · Apply lubricant to the raceway and rolling contact surface when mounting. · Improve mounting procedure.
	Scuffing on rib face and roller end face	<ul style="list-style-type: none"> · Improper or insufficient lubricant · Improper mounting · Excessive axial load 	<ul style="list-style-type: none"> · Select proper lubricating method or lubricant. · Correct centering of axial direction.
	Smearing on raceway or rolling contact surface	<ul style="list-style-type: none"> · Improper or insufficient lubricant · Slipping of the rolling elements <p style="text-align: center;"> { This occurs due to the break down of lubricant film when an abnormal self rotation causes slip of the rolling elements on the raceway. } </p>	<ul style="list-style-type: none"> · Select proper lubricating method or lubricant. · Provide proper preload.
	Rust partially or completely covering the bearing surface.	<ul style="list-style-type: none"> · Improper storage condition · Dew formation in atmosphere 	<ul style="list-style-type: none"> · Improve bearing storage conditions. · Improve sealing devices. · Provide rust preventive treatment before long cessation of operation.
	Rust and corrosion at the same interval as rolling element spacing	<ul style="list-style-type: none"> · Contamination by water or corrosive matter 	<ul style="list-style-type: none"> · Improve sealing devices.
	Pitting or a corrugated surface failure on raceway and rolling contact surface { The bearings must be replaced, if the corrugated texture is found by scratching the surface with a fingernail or if pitting can be observed by visual inspection. }	<ul style="list-style-type: none"> · Sparks generated when electric current passes through bearings 	<ul style="list-style-type: none"> · Providing a bypass which prevents current from passing through bearings. · Insulation of bearings.

Table 16-1 (3) Bearing failures, causes and countermeasures

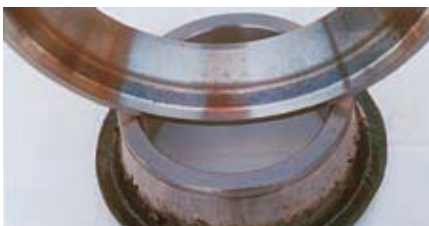
Failures	Characteristics		
<p>9 Wear</p>	 <p>(A-4719)</p>	<p>Normally, wear of bearing is observed on sliding contact surfaces such as roller end faces and rib faces, cage pockets, the guide surface of cages and cage riding lands. Wear is not directly related to material fatigue.</p> <p>Wear caused by foreign matter and corrosion can affect not only sliding surfaces but rolling surfaces.</p>	
<p>10 Fretting</p>	 <p>(A-6649)</p>	<p>Fretting occurs to bearings which are subject to vibration while in stationary condition or which are exposed to minute vibration. It is characterized by rust-colored wear particles.</p> <p>Since fretting on the raceways often appears similar to brinelling, it is sometimes called "falsebrinelling".</p>	
<p>11 Creeping</p>	 <p>(A-6647)</p>	<p>Creeping is a phenomenon in which bearing rings move relative to the shaft or housing during operation.</p>	
<p>12 Damage to cages</p>	 <p>(A-6455)</p>	<p>Since cages are made of low hardness materials, external pressure and contact with other parts can easily produce flaws and distortion. In some cases, these are aggravated and become chipping and cracks.</p> <p>Large chipping and cracks are often accompanied by deformation, which may reduce the accuracy of the cage itself and may hinder the smooth movement of rolling elements.</p>	
<p>13 Seizure</p>	 <p>(A-6679)</p>	<p>A phenomenon caused by abnormal heating in bearings.</p>	

	Damages	Causes	Countermeasures
	Wear on the contact surfaces (roller end faces, rib faces, cage pockets)	Improper or insufficient lubricant	<ul style="list-style-type: none"> · Select proper lubricating method or lubricant. · Improve sealing device. · Clean the bearing and its peripheral parts.
	Wear on raceways and rolling contact surfaces	<ul style="list-style-type: none"> · Entry of foreign matter · Improper or insufficient lubricant 	
	Rust-colored wear particles generated on the fitting surface (fretting corrosion)	<ul style="list-style-type: none"> · Insufficient interference 	<ul style="list-style-type: none"> · Provide greater interference · Apply lubricant to the fitting surface
	Brinelling on the raceway surface at the same interval as rolling element spacing (false brinelling)	<ul style="list-style-type: none"> · Vibration and oscillation when bearings are stationary. 	<ul style="list-style-type: none"> · Improve fixing method of the shaft and housing. · Provide preload to bearing.
	Wear, discoloration and scuffing, caused by slipping on the fitting surfaces	<ul style="list-style-type: none"> · Insufficient interference · Insufficient tightening of sleeve 	<ul style="list-style-type: none"> · Provide greater interference. · Proper tightening of sleeve.
	Flaws, distortion, chipping, cracking and excessive wear in cages. Loose or damaged rivets.	<ul style="list-style-type: none"> · Extraordinary vibration, impact, moment · Improper or insufficient lubricant · Improper mounting (misalignment) · Dents made during mounting 	<ul style="list-style-type: none"> · Re-examine load conditions. · Select proper lubricating method or lubricant. · Minimize mounting deviation. · Re-examine cage types. · Improve mounting.
	Discoloration, distortion and melting together	<ul style="list-style-type: none"> · Too small internal clearance · Improper or insufficient lubricant · Excessive load · Aggravated by other bearing flaws 	<ul style="list-style-type: none"> · Provide proper internal clearance. · Select proper lubricating method or lubricant. · Re-examine bearing type. · Earlier discovery of bearing flaws.

Bearing specification tables

Contents

Standard bearings

Deep groove ball bearings	B 4
Single-row	
Open type.....	B 8
Shielded/sealed type	B 20
Snap ring groove/locating snap ring type	B 32
Extra-small, miniature ball bearings	
Open/shielded/sealed type.....	B 38
Flanged type (open/shielded type)	B 44
Double-row	B 50

Angular contact ball bearings	B 52
Single-row	B 60
Matched pair	B 92
Double-row	B 124
Four-point contact ball bearings	B 130

Self-aligning ball bearings	B 134
Open type	B 136
Sealed type	B 144
Extended inner ring type	B 148
Adapter assemblies for self-aligning ball bearings ...	B 150

Cylindrical roller bearings	B 154
Single-row	B 158
Thrust collars	B 184
Double-row	B 194

Tapered roller bearings	B 200
Single-row	
Metric series	B 204
Inch series	B 236
Double-row	
TDO type	B 280
TDI type.....	B 296

Spherical roller bearings	B 302
Spherical roller bearings	B 306
Adapter assemblies for spherical roller bearings	B 330
Withdrawal sleeves for spherical roller bearings	B 338

Thrust ball bearings	B 348
Single direction	B 350
Double direction	B 360

Spherical thrust roller bearings	B 366
---	-------

Needle roller bearings	B 374
Needle roller and cage assemblies ...	B 388
Drawn cup type	B 402
Machined ring type	B 424
Thrust	B 440
Stud type track rollers (cam followers)	B 450
Yoke type track rollers (roller followers)	B 454
(Miniature one-way clutches)	B 458

Ball bearing units	B 462
Pillow block type	
With set screws	B 470
With adapter	B 476
Thick section	B 480
Light duty	B 482
“Compact” series	B 484
Stainless-series	B 486
Pressed steel.....	B 488
Square-flanged type	B 490
Square-flanged type with spigot joint	B 496
Rhombic-flanged type	B 500
Light duty	B 504
“Compact” series	B 506
Stainless-series	B 508

(Ball bearing units)

Round-flanged type with spigot joint B 510
 Pressed steel round-flanged type B 514
 Pressed steel rhombic-flanged type B 516
 Take-up type B 518
 Cartridge type B 524
 Ball bearings for units
 Cylindrical bore type (with set screws) ... B 528
 Tapered bore type (with adapter) ... B 534
 Cylindrical bore type (with eccentric locking collar)... B 538

Plummer blocks B 540
 Split type
 Standard B 544
 Flat bottom B 552
 Flat bottom (different/large bore type) B 558
 Large size B 564
 One-piece type B 570

Special purpose bearings

Ceramic & EXSEV bearing series C 1
 Vacuum environment..... C 9
 Clean environment C 13
 Ceramic bearings C 17
 Hybrid ceramic bearings..... C 21
 Linear ball bearings for vacuum C 25

K-series super thin section

ball bearings C 27
 Deep groove type
 Angular contact type
 Four-point contact type
 Sealed type C 45

Bearings for machine tool spindles

(for support of axial loading) C 47
 Double direction
 angular contact thrust ball bearings C 53
 Matched pair angular contact ball bearings C 59

Precision ball screw support bearings

and bearing units C 65
 Support bearings..... C 67
 Support bearing units..... C 69

Full complement type cylindrical roller

bearings for crane sheaves C 71
 Shielded type C 73
 Open type C 77

Rolling mill roll neck bearings C 81

 Four-row cylindrical roller bearings..... C 85
 Four-row tapered roller bearings..... C 103
 Sealed type four-row tapered roller bearings... C 127

Bearings for railway

rolling stock axle journals C 139
 Cylindrical roller bearings C 143
 Sealed type cylindrical roller bearings C 145
 Sealed type tapered roller bearings
 (ABU bearing) C 147

Linear ball bearings C 149

 Linear ball bearings C 153
 Flanged type C 159

Accessories C 163

 Locknuts C 165
 Lockwashers C 171
 Lock plates C 173

KOYO



Deep groove ball bearings

Deep groove ball bearings are available in a variety of sizes, and are the most popular of all rolling bearings. This type of bearing supports radial load and a certain degree of axial load in both directions simultaneously.

- Shielded / sealed type
 - Simplifies sealing structure of applications.
 - Greasing is not necessary because bearings are pre-lubricated.
 - Table 1 on the next page lists major shielded and sealed bearing types and compares their performance.
- With locating snap ring
 - Bearings with a locating snap ring can be fit to the housing easily, as the locating snap ring facilitates axial positioning.
- Extra-small ball bearings and miniature ball bearings
 - The open type is widely used. Also available are the shielded/sealed type and the flanged type; the latter is easily positioned in the axial direction.

Single-row deep groove ball bearings



Open type

Bore diameter 10 – 500 mm



Shielded/sealed type

Bore diameter 10 – 220 mm

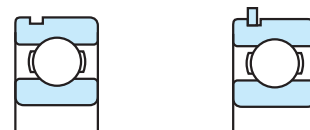

With snap ring groove With locating snap ring

Bore diameter 10 – 130 mm

Extra-small ball bearings and miniature ball bearings

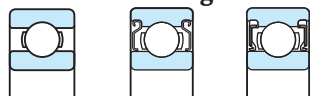

Bore diameter 1 – 9 mm



Flanged type

Bore diameter 1 – 9 mm

Double-row deep groove ball bearings

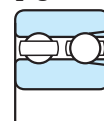

(with filling slot)

Bore diameter 10 – 75 mm

Table 1 Comparison of shielded and sealed bearing performance

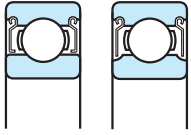
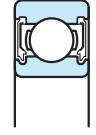
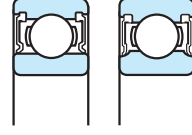
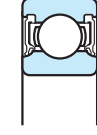
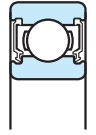
Type	Shielded		Sealed			
	Non-contact type		Non-contact type	Contact type		Extremely light contact type
	ZZ type		2RU type	2RS type	2RK type	2RD type
	 (a) ¹⁾ (b)		 (c)	 (d) ²⁾ (e)	 (f)	 (g)
Characteristics						
Friction torque	Small		Small	Large	Large	Small
High speed performance	Good		Good	Limited because of contact		Good
Grease sealing property	Good		Better than ZZ type	Better than 2RU type for low-speed applications	Excellent	Excellent
Dirt resistance	Good		Better than ZZ type	Better than 2RU type	Excellent	Excellent
Water resistance	Economical		Better than ZZ type but inferior to 2RS, 2RK and 2RD types	Good	Excellent	Better than ZZ and 2RU types
Operating temperature ³⁾	- 30 to +110°C			- 30 to +100°C		- 30 to +110°C

[Notes] 1) Illustration (a) of the ZZ type shows the relatively small size bearing.

2) Illustration (d) of the 2RS type shows the relatively small size bearing.

3) The operating temperature range listed is for the standard type. It can be widened by using a different type of grease or sealing material. Consult with JTEKT for details.

■ Handling instructions

- 1) The shielded/sealed type deep groove ball bearing and the deep groove ball bearing with a locating snap ring are designed for use with the inner ring rotating.
Consult with JTEKT on use with the outer ring rotating.
- 2) When the axial load is large, make the shaft shoulder and housing shoulder larger than usual.
(Referring to the specification table, make the mounting dimension d_a larger and make D_a smaller.)

Boundary dimensions	The dimensions of standard series are as specified in JIS B 1512. For extra-small and miniature ball bearings, special series (ML) are specified together with those described above.																																																																														
Tolerances	As specified in JIS B 1514-1. (refer to Table 7-3 on pp. A 54 – A 57.)																																																																														
Radial internal clearance	<ul style="list-style-type: none"> ■ Deep groove ball bearings (except extra-small ball bearings and miniature ball bearings) as specified in JIS B 1520 (refer to Table 10-2 on p. A 96.) ■ Extra-small ball bearings and miniature ball bearings (refer to Table 10-3 on p. A 96.) ■ Deep groove ball bearings for motors (refer to Table 10-7 on p. A 99.) 																																																																														
Recommended fits	<ul style="list-style-type: none"> ■ Bearings of classes 0 and 6 (refer to Table 9-4 on pp. A 85, 86.) ■ Precision extra-small ball bearings and miniature ball bearings (refer to Table 9-5 on p. A 87.) 																																																																														
Standard cages	<ul style="list-style-type: none"> ● Polyamide molded cage (supplementary code : FG, MG) ● Pressed steel cage (supplementary code : //) ● Copper alloy machined cage (supplementary code : FY) <p>[Remark] For certain applications, stainless steel sheet pressed cages (YS) may also be used.</p>	Application of standard cages																																																																													
		<table border="1"> <thead> <tr> <th>Bearing series</th> <th>Molded cage</th> <th>Pressed cage</th> <th colspan="2">Machined cage</th> </tr> </thead> <tbody> <tr><td>68</td><td>683 – 689</td><td>-</td><td colspan="2">-</td></tr> <tr><td>69</td><td>693 – 699</td><td>-</td><td colspan="2">-</td></tr> <tr><td>60</td><td>603 – 609</td><td>-</td><td colspan="2">-</td></tr> <tr><td>62</td><td>623 – 629</td><td>-</td><td colspan="2">-</td></tr> <tr><td>63</td><td>633 – 639</td><td>-</td><td colspan="2">-</td></tr> <tr><td>68</td><td>-</td><td>6800 – 6838</td><td colspan="2">6840 – 68/600</td></tr> <tr><td>69</td><td>-</td><td>6900 – 6918</td><td colspan="2">6920 – 6980</td></tr> <tr><td>160</td><td>-</td><td>16001 – 16028</td><td colspan="2">16030 – 16072</td></tr> <tr><td>60</td><td>6000 – 6009</td><td>6010 – 6034</td><td colspan="2">6036 – 6084</td></tr> <tr><td>62</td><td>6200 – 6208</td><td>6209 – 6230</td><td colspan="2">6232 – 6248</td></tr> <tr><td>63</td><td>6300 – 6306</td><td>6307 – 6328</td><td colspan="2">6330 – 6340</td></tr> <tr><td>64</td><td>-</td><td>6403 – 6418</td><td colspan="2">-</td></tr> <tr><td>42</td><td>-</td><td>4200 – 4215</td><td colspan="2">-</td></tr> <tr><td>43</td><td>-</td><td>4302 – 4315</td><td colspan="2">-</td></tr> </tbody> </table>	Bearing series	Molded cage	Pressed cage	Machined cage		68	683 – 689	-	-		69	693 – 699	-	-		60	603 – 609	-	-		62	623 – 629	-	-		63	633 – 639	-	-		68	-	6800 – 6838	6840 – 68/600		69	-	6900 – 6918	6920 – 6980		160	-	16001 – 16028	16030 – 16072		60	6000 – 6009	6010 – 6034	6036 – 6084		62	6200 – 6208	6209 – 6230	6232 – 6248		63	6300 – 6306	6307 – 6328	6330 – 6340		64	-	6403 – 6418	-		42	-	4200 – 4215	-		43	-	4302 – 4315	-			
Bearing series	Molded cage	Pressed cage	Machined cage																																																																												
68	683 – 689	-	-																																																																												
69	693 – 699	-	-																																																																												
60	603 – 609	-	-																																																																												
62	623 – 629	-	-																																																																												
63	633 – 639	-	-																																																																												
68	-	6800 – 6838	6840 – 68/600																																																																												
69	-	6900 – 6918	6920 – 6980																																																																												
160	-	16001 – 16028	16030 – 16072																																																																												
60	6000 – 6009	6010 – 6034	6036 – 6084																																																																												
62	6200 – 6208	6209 – 6230	6232 – 6248																																																																												
63	6300 – 6306	6307 – 6328	6330 – 6340																																																																												
64	-	6403 – 6418	-																																																																												
42	-	4200 – 4215	-																																																																												
43	-	4302 – 4315	-																																																																												
Allowable misalignment	0.002 3 – 0.003 4 rad (8' – 12')																																																																														
Equivalent radial load (Single/double-row)	Dynamic equivalent radial load $P_r = XF_r + YF_a$ (refer to the table on the right for values <i>X</i> and <i>Y</i> .) Static equivalent radial load $P_{0r} = 0.6F_r + 0.5F_a$ (when the value of $P_{0r} < F_r$, $P_{0r} = F_r$)	<table border="1"> <thead> <tr> <th rowspan="2">$\frac{if_0F_a}{C_{0r}}$</th> <th rowspan="2"><i>e</i></th> <th colspan="2">$\frac{F_a}{F_r} \leq e$</th> <th colspan="2">$\frac{F_a}{F_r} > e$</th> </tr> <tr> <th><i>X</i></th> <th><i>Y</i></th> <th><i>X</i></th> <th><i>Y</i></th> </tr> </thead> <tbody> <tr><td>0.172</td><td>0.19</td><td></td><td></td><td></td><td>2.30</td></tr> <tr><td>0.345</td><td>0.22</td><td></td><td></td><td></td><td>1.99</td></tr> <tr><td>0.689</td><td>0.26</td><td></td><td></td><td></td><td>1.71</td></tr> <tr><td>1.03</td><td>0.28</td><td></td><td></td><td></td><td>1.55</td></tr> <tr><td>1.38</td><td>0.30</td><td>1</td><td>0</td><td>0.56</td><td>1.45</td></tr> <tr><td>2.07</td><td>0.34</td><td></td><td></td><td></td><td>1.31</td></tr> <tr><td>3.45</td><td>0.38</td><td></td><td></td><td></td><td>1.15</td></tr> <tr><td>5.17</td><td>0.42</td><td></td><td></td><td></td><td>1.04</td></tr> <tr><td>6.89</td><td>0.44</td><td></td><td></td><td></td><td>1.00</td></tr> </tbody> </table>				$\frac{if_0F_a}{C_{0r}}$	<i>e</i>	$\frac{F_a}{F_r} \leq e$		$\frac{F_a}{F_r} > e$		<i>X</i>	<i>Y</i>	<i>X</i>	<i>Y</i>	0.172	0.19				2.30	0.345	0.22				1.99	0.689	0.26				1.71	1.03	0.28				1.55	1.38	0.30	1	0	0.56	1.45	2.07	0.34				1.31	3.45	0.38				1.15	5.17	0.42				1.04	6.89	0.44				1.00										
		$\frac{if_0F_a}{C_{0r}}$	<i>e</i>	$\frac{F_a}{F_r} \leq e$				$\frac{F_a}{F_r} > e$																																																																							
<i>X</i>	<i>Y</i>			<i>X</i>	<i>Y</i>																																																																										
0.172	0.19				2.30																																																																										
0.345	0.22				1.99																																																																										
0.689	0.26				1.71																																																																										
1.03	0.28				1.55																																																																										
1.38	0.30	1	0	0.56	1.45																																																																										
2.07	0.34				1.31																																																																										
3.45	0.38				1.15																																																																										
5.17	0.42				1.04																																																																										
6.89	0.44				1.00																																																																										
		Factor <i>f</i> ₀ is shown in the bearing dimension table.																																																																													

Single-row deep groove ball bearings

open type

d 10 ~ (20) mm

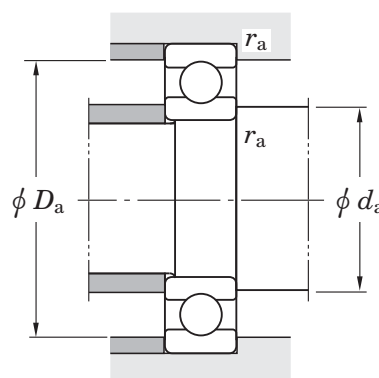
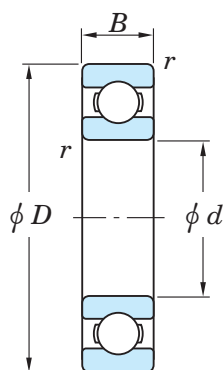

Boundary dimensions (mm)				Basic load ratings (kN)		Factor	Limiting speeds (min ⁻¹)		Bearing No.	Mounting dimensions (mm)			(Refer.) Mass (kg)
d	D	B	$r_{\min.}$	C_r	C_{0r}	f_0	Grease lub.	Oil lub.		d_a min.	D_a max.	r_a max.	
10	19	5	0.3	1.70	0.84	14.8	37 000	43 000	6800	12	17	0.3	0.005
	22	6	0.3	2.70	1.25	14.0	34 000	41 000	6900	12	20	0.3	0.010
	26	8	0.3	4.55	1.95	12.3	31 000	36 000	6000	12	24	0.3	0.019
	30	9	0.6	5.10	2.40	13.2	24 000	29 000	6200	14	26	0.6	0.032
	35	11	0.6	8.10	3.45	11.2	22 000	27 000	6300	14	31	0.6	0.053
12	21	5	0.3	1.90	1.05	15.3	33 000	39 000	6801	14	19	0.3	0.006
	24	6	0.3	2.90	1.45	14.5	31 000	36 000	6901	14	22	0.3	0.011
	28	7	0.3	5.10	2.40	13.2	27 000	32 000	16001	14	26	0.3	0.024
	28	8	0.3	5.10	2.40	13.2	27 000	32 000	6001	14	26	0.3	0.022
	32	10	0.6	6.80	3.05	12.3	22 000	27 000	6201	16	28	0.6	0.037
	37	12	1	9.70	4.20	11.1	20 000	25 000	6301	17	32	1	0.060
15	24	5	0.3	2.10	1.25	15.8	28 000	33 000	6802	17	22	0.3	0.007
	28	7	0.3	4.30	2.25	14.3	26 000	30 000	6902	17	26	0.3	0.017
	32	8	0.3	5.60	2.85	13.9	23 000	28 000	16002	17	30	0.3	0.025
	32	9	0.3	5.60	2.85	13.9	23 000	27 000	6002	17	30	0.3	0.030
	35	11	0.6	7.65	3.75	13.2	20 000	24 000	6202	19	31	0.6	0.045
	42	13	1	11.4	5.45	12.3	17 000	20 000	6302	20	37	1	0.082
17	26	5	0.3	2.60	1.55	15.7	26 000	30 000	6803	19	24	0.3	0.008
	30	7	0.3	4.60	2.55	14.7	23 000	28 000	6903	19	28	0.3	0.018
	35	8	0.3	6.00	3.25	14.4	21 000	25 000	16003	19	33	0.3	0.032
	35	10	0.3	6.00	3.25	14.4	21 000	25 000	6003	19	33	0.3	0.039
	40	12	0.6	9.55	4.80	13.2	17 000	21 000	6203	21	36	0.6	0.065
	47	14	1	13.6	6.65	12.4	15 000	18 000	6303	22	42	1	0.115
	47	14	1	15.6	7.60	12.0	15 000	18 000	6303R	22	42	1	0.121
	62	17	1.1	20.7	9.85	11.6	13 000	15 000	6403	23.5	55.5	1	0.270
20	32	7	0.3	4.00	2.45	15.5	21 000	25 000	6804	22	30	0.3	0.018
	37	9	0.3	6.35	3.70	14.7	19 000	23 000	6904	22	35	0.3	0.036
	42	8	0.3	7.95	4.50	14.4	17 000	21 000	16004	22	40	0.3	0.050

[Remark] Standard cage types used for the above bearings are described earlier in this section.

d (20) ~ (30) mm

Boundary dimensions (mm)				Basic load ratings (kN)		Factor	Limiting speeds (min ⁻¹)		Bearing No.	Mounting dimensions (mm)			(Refer.) Mass (kg)
d	D	B	$r_{\min.}$	C_r	C_{0r}	f_0	Grease lub.	Oil lub.		d_a min.	D_a max.	r_a max.	
20	42	12	0.6	9.40	5.05	13.9	17 000	21 000	6004	24	38	0.6	0.069
	42	12	0.6	11.5	5.85	13.0	18 000	21 000	6004R	24	38	0.6	0.073
	47	14	1	12.8	6.65	13.2	15 000	17 000	6204	25	42	1	0.106
	47	14	1	15.6	7.60	12.0	15 000	18 000	6204R	25	42	1	0.114
	52	15	1.1	15.9	7.85	12.3	14 000	17 000	6304	26.5	45.5	1	0.144
	52	15	1.1	18.1	8.95	12.0	14 000	16 000	6304R	26.5	45.5	1	0.151
	72	19	1.1	31.0	15.2	11.1	11 000	13 000	6404	26.5	65.5	1	0.400
22	44	12	0.6	9.40	5.15	14.1	17 000	20 000	60/22	26	40	0.6	0.073
	50	14	1	12.8	6.65	13.2	15 000	17 000	62/22	27	45	1	0.118
	56	16	1.1	18.5	9.40	12.6	13 000	15 000	63/22	28.5	49.5	1	0.201
25	37	7	0.3	4.30	2.95	16.0	18 000	21 000	6805	27	35	0.3	0.022
	42	9	0.3	7.00	4.55	15.4	16 000	19 000	6905	27	40	0.3	0.041
	47	8	0.3	8.85	5.60	15.1	15 000	18 000	16005	27	45	0.3	0.060
	47	12	0.6	10.1	5.85	14.5	15 000	18 000	6005	29	43	0.6	0.080
	52	15	1	14.0	7.85	13.9	13 000	15 000	6205	30	47	1	0.128
	52	15	1	17.6	9.30	12.8	13 000	16 000	6205R	30	47	1	0.138
	62	17	1.1	20.6	11.3	13.2	11 000	13 000	6305	31.5	55.5	1	0.232
	62	17	1.1	26.2	13.4	11.9	11 000	14 000	6305R	31.5	55.5	1	0.255
	80	21	1.5	36.1	19.4	12.2	9 100	11 000	6405	33	72	1.5	0.530
28	52	12	0.6	12.4	7.40	14.5	14 000	16 000	60/28	32	48	0.6	0.097
	58	16	1	17.9	9.75	13.4	12 000	14 000	62/28	33	53	1	0.173
	68	18	1.1	23.5	13.1	13.3	10 000	12 000	63/28	34.5	61.5	1	0.328
30	42	7	0.3	4.55	3.40	16.4	15 000	18 000	6806	32	40	0.3	0.026
	47	9	0.3	7.25	5.00	15.8	14 000	17 000	6906	32	45	0.3	0.045
	55	9	0.3	11.2	7.35	15.2	13 000	15 000	16006	32	53	0.3	0.085
	55	13	1	13.2	8.25	14.7	13 000	15 000	6006	35	50	1	0.116
	62	16	1	19.5	11.3	13.9	11 000	13 000	6206	35	57	1	0.199
	62	16	1	23.4	12.8	13.0	11 000	13 000	6206R	35	57	1	0.212

Single-row deep groove ball bearings open type

d (30) ~ (45) mm

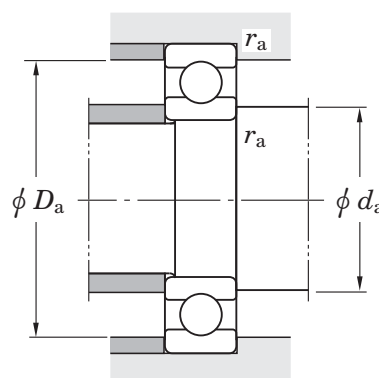
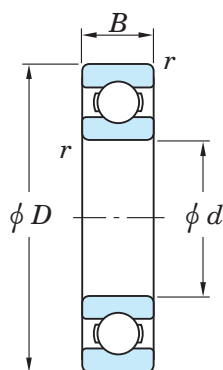

Boundary dimensions (mm)				Basic load ratings (kN)		Factor	Limiting speeds (min ⁻¹)		Bearing No.	Mounting dimensions (mm)			(Refer.) Mass (kg)
d	D	B	$r_{\min.}$	C_R	C_{Or}	f_0	Grease lub.	Oil lub.		d_a min.	D_a max.	r_a max.	
30	72	19	1.1	26.7	15.0	13.3	9 600	12 000	6306 6306R 6406	36.5	65.5	1	0.346
	72	19	1.1	33.4	17.7	12.0	9 800	12 000		36.5	65.5	1	0.379
	90	23	1.5	43.4	23.9	12.3	8 100	9 700		38	82	1.5	0.735
32	58	13	1	15.0	9.15	14.5	12 000	14 000	60/32 62/32 63/32	37	53	1	0.127
	65	17	1	23.5	13.1	13.3	10 000	12 000		37	60	1	0.228
	75	20	1.1	30.1	16.2	12.7	9 300	11 000		38.5	68.5	1	0.437
35	47	7	0.3	4.75	3.85	16.5	13 000	16 000	6807 6907 16007 6007 6207 6207R 6307 6307R 6407	37	45	0.3	0.030
	55	10	0.6	10.9	7.75	15.7	12 000	14 000		39	51	0.6	0.073
	62	9	0.3	12.2	8.85	15.7	11 000	13 000		37	60	0.3	0.110
	62	14	1	15.9	10.3	14.9	11 000	13 000		40	58	1	0.155
	72	17	1.1	25.7	15.4	13.9	9 200	11 000		41.5	65.5	1	0.288
	72	17	1.1	31.0	17.5	12.9	9 300	11 000		41.5	65.5	1	0.309
	80	21	1.5	33.4	19.3	13.2	8 500	10 000		43	72	1.5	0.457
	80	21	1.5	40.0	21.7	12.1	8 700	10 000		43	72	1.5	0.494
100	25	1.5	55.0	31.0	12.2	7 200	8 600	43	92	1.5	0.952		
40	52	7	0.3	4.95	4.20	16.3	12 000	14 000	6808 6908 16008 6008 6208 6308 6408	42	50	0.3	0.033
	62	12	0.6	13.7	9.95	15.6	11 000	13 000		44	58	0.6	0.112
	68	9	0.3	12.6	9.65	16.0	9 800	12 000		42	66	0.3	0.125
	68	15	1	16.7	11.5	15.2	10 000	12 000		45	63	1	0.192
	80	18	1.1	29.1	17.8	14.0	8 300	10 000		46.5	73.5	1	0.366
	90	23	1.5	40.7	24.0	13.2	7 700	9 200		48	82	1.5	0.633
	110	27	2	63.7	36.6	12.3	6 600	7 900		49	101	2	1.23
45	58	7	0.3	6.20	5.40	16.3	11 000	13 000	6809 6909 16009 6009 6209 6309	47	56	0.3	0.040
	68	12	0.6	14.1	10.9	15.9	9 700	11 000		49	64	0.6	0.132
	75	10	0.6	15.5	12.3	16.0	8 900	10 000		49	71	0.6	0.170
	75	16	1	21.0	15.1	15.3	9 200	11 000		50	70	1	0.245
	85	19	1.1	32.7	20.3	14.0	7 700	9 200		51.5	78.5	1	0.407
	100	25	1.5	48.9	29.5	13.3	6 800	8 100		53	92	1.5	0.833

[Remark] Standard cage types used for the above bearings are described earlier in this section.

d (45) ~ (65) mm

Boundary dimensions (mm)				Basic load ratings (kN)		Factor	Limiting speeds (min ⁻¹)		Bearing No.	Mounting dimensions (mm)			(Refer.) Mass (kg)
<i>d</i>	<i>D</i>	<i>B</i>	<i>r</i> _{min.}	<i>C_r</i>	<i>C_{0r}</i>	<i>f</i> ₀	Grease lub.	Oil lub.		<i>d</i> _a min.	<i>D</i> _a max.	<i>r</i> _a max.	
45	120	29	2	77.2	45.1	12.2	6 000	7 200	6409	54	111	2	1.53
50	65	7	0.3	6.60	6.10	16.1	9 600	11 000	6810	52	63	0.3	0.052
	72	12	0.6	14.5	11.7	16.1	9 000	11 000	6910	54	68	0.6	0.133
	80	10	0.6	16.0	13.3	16.2	8 200	9 700	16010	54	76	0.6	0.180
	80	16	1	21.8	16.6	15.6	8 400	9 900	6010	55	75	1	0.261
	90	20	1.1	35.1	23.3	14.4	7 100	8 500	6210	56.5	83.5	1	0.463
	90	20	1.1	40.4	25.5	13.9	7 100	8 600	6210R	56.5	83.5	1	0.487
	110	27	2	62.0	38.3	13.2	6 100	7 300	6310	59	101	2	1.07
130	31	2.1	83.0	49.5	12.5	5 500	6 600	6410	61	119	2	1.88	
55	72	9	0.3	8.80	8.10	16.2	8 700	10 000	6811	57	70	0.3	0.083
	80	13	1	16.6	14.1	16.2	8 100	9 600	6911	60	75	1	0.185
	90	11	0.6	19.3	16.3	16.2	7 400	8 800	16011	59	86	0.6	0.260
	90	18	1.1	28.3	21.2	15.3	7 600	8 900	6011	61.5	83.5	1	0.385
	100	21	1.5	43.4	29.4	14.4	6 300	7 600	6211	63	92	1.5	0.607
	120	29	2	71.6	45.0	13.2	5 600	6 700	6311	64	111	2	1.37
	140	33	2.1	100	62.3	12.2	5 000	6 000	6411	66	129	2	2.29
60	78	10	0.3	11.5	10.6	16.3	8 000	9 400	6812	62	76	0.3	0.104
	85	13	1	20.2	17.3	16.2	7 500	8 900	6912	65	80	1	0.192
	95	11	0.6	19.8	17.6	16.4	6 900	8 100	16012	64	91	0.6	0.280
	95	18	1.1	29.4	23.2	15.6	7 100	8 400	6012	66.5	88.5	1	0.415
	110	22	1.5	52.4	36.2	14.4	5 700	6 900	6212	68	102	1.5	0.783
	130	31	2.1	81.9	52.2	13.2	5 200	6 200	6312	71	119	2	1.70
	150	35	2.1	110	70.8	12.4	4 600	5 500	6412	71	139	2	2.77
65	85	10	0.6	11.9	11.5	16.2	7 300	8 600	6813	69	81	0.6	0.126
	90	13	1	17.4	16.1	16.6	7 100	8 400	6913	70	85	1	0.211
	100	11	0.6	17.1	16.0	16.5	6 600	7 800	16013	69	96	0.6	0.300
	100	18	1.1	30.5	25.2	15.8	6 600	7 800	6013	71.5	93.5	1	0.435

Single-row deep groove ball bearings open type

d (65) ~ (85) mm

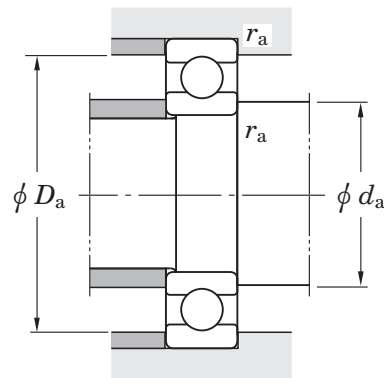
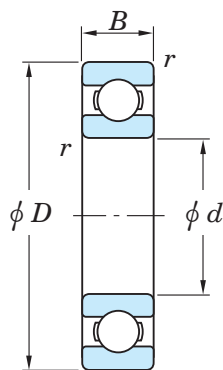

Boundary dimensions (mm)				Basic load ratings (kN)		Factor f_0	Limiting speeds (min^{-1})		Bearing No.	Mounting dimensions (mm)			(Refer.) Mass (kg)
d	D	B	$r_{\text{min.}}$	C_R	C_{0R}		Grease lub.	Oil lub.		d_a min.	D_a max.	r_a max.	
65	120	23	1.5	57.2	40.1	14.4	5 400	6 400	6213	73	112	1.5	0.990
	140	33	2.1	92.7	59.9	13.2	4 800	5 800	6313	76	129	2	2.08
	160	37	2.1	118	79.2	12.4	4 300	5 200	6413	76	149	2	3.30
70	90	10	0.6	12.1	11.9	16.1	6 800	8 100	6814	74	86	0.6	0.134
	100	16	1	23.7	21.2	16.3	6 400	7 600	6914	75	95	1	0.342
	110	13	0.6	30.1	25.6	16.0	6 100	7 200	16014	74	106	0.6	0.433
	110	20	1.1	38.1	30.9	15.6	6 100	7 200	6014	76.5	103.5	1	0.602
	125	24	1.5	62.2	44.1	14.5	5 100	6 100	6214	78	117	1.5	1.07
	150	35	2.1	104	68.2	13.2	4 500	5 400	6314	81	139	2	2.52
	180	42	3	144	104	12.2	3 900	4 600	6414	83	167	2.5	4.83
75	95	10	0.6	12.5	12.9	16.0	6 400	7 600	6815	79	91	0.6	0.142
	105	16	1	24.4	22.6	16.5	6 100	7 200	6915	80	100	1	0.363
	115	13	0.6	27.5	25.3	16.4	5 700	6 700	16015	79	111	0.6	0.457
	115	20	1.1	39.6	33.5	15.8	5 700	6 800	6015	81.5	108.5	1	0.638
	130	25	1.5	67.4	48.3	14.5	4 800	5 800	6215	83	122	1.5	1.18
	160	37	2.1	113	77.2	13.2	4 200	5 000	6315	86	149	2	3.02
	190	45	3	154	115	12.3	3 600	4 400	6415	88	177	2.5	5.87
80	100	10	0.6	12.7	13.3	16.0	6 100	7 200	6816	84	96	0.6	0.150
	110	16	1	25.0	24.0	16.6	5 700	6 800	6916	85	105	1	0.382
	125	14	0.6	31.7	29.7	16.4	5 200	6 100	16016	84	121	0.6	0.597
	125	22	1.1	47.6	39.8	15.6	5 300	6 300	6016	86.5	118.5	1	0.850
	140	26	2	72.7	53.0	14.6	4 500	5 400	6216	89	131	2	1.40
	170	39	2.1	123	86.7	13.3	3 900	4 700	6316	91	159	2	3.59
	200	48	3	164	125	12.3	3 400	4 100	6416	93	187	2.5	6.84
85	110	13	1	18.7	19.0	16.2	5 600	6 600	6817	90	105	1	0.266
	120	18	1.1	31.9	29.6	16.4	5 300	6 300	6917	91.5	113.5	1	0.535
	130	14	0.6	32.6	31.7	16.5	4 900	5 800	16017	89	126	0.6	0.626

[Remark] Standard cage types used for the above bearings are described earlier in this section.

d (85) ~ 105 mm

Boundary dimensions (mm)				Basic load ratings (kN)		Factor	Limiting speeds (min ⁻¹)		Bearing No.	Mounting dimensions (mm)			(Refer.) Mass (kg)
d	D	B	$r_{\min.}$	C_r	C_{0r}	f_0	Grease lub.	Oil lub.		d_a min.	D_a max.	r_a max.	
85	130	22	1.1	49.5	43.1	15.8	5 000	5 900	6017	91.5	123.5	1	0.890
	150	28	2	84.0	61.9	14.5	4 200	5 000	6217	94	141	2	1.79
	180	41	3	133	96.8	13.3	3 700	4 400	6317	98	167	2.5	4.23
	210	52	4	173	136	12.3	3 300	3 900	6417	101	194	3	8.07
90	115	13	1	19.0	19.7	16.1	5 300	6 300	6818	95	110	1	0.279
	125	18	1.1	32.8	31.6	16.5	5 100	6 000	6918	96.5	118.5	1	0.565
	140	16	1	39.9	37.0	16.3	4 700	5 600	16018	95	135	1	0.848
	140	24	1.5	58.2	49.7	15.6	4 700	5 600	6018	98	132	1.5	1.16
	160	30	2	96.1	71.5	14.5	3 900	4 700	6218	99	151	2	2.15
	190	43	3	143	107	13.3	3 500	4 200	6318	103	177	2.5	4.91
	225	54	4	184	149	12.5	3 100	3 700	6418	106	209	3	9.78
95	130	18	1.1	33.7	33.5	16.6	4 800	5 700	6919	101.5	123.5	1	0.705
	145	16	1	41.2	39.6	16.4	4 500	5 300	16019	100	140	1	0.885
	145	24	1.5	60.4	53.9	15.8	4 400	5 200	6019	103	137	1.5	1.21
	170	32	2.1	109	81.9	14.4	3 700	4 400	6219	106	159	2	2.62
	200	45	3	153	119	13.3	3 300	4 000	6319	108	187	2.5	5.67
100	125	13	1	19.6	21.2	16.0	4 800	5 700	6820	105	120	1	0.309
	140	20	1.1	45.0	41.9	16.2	4 500	5 300	6920	106.5	133.5	1	0.960
	150	16	1	42.4	42.1	16.5	4 300	5 100	16020	105	145	1	0.910
	150	24	1.5	60.2	54.2	15.9	4 300	5 100	6020	108	142	1.5	1.25
	180	34	2.1	122	93.1	14.4	3 500	4 200	6220	111	169	2	3.14
	215	47	3	173	141	13.2	3 000	3 600	6320	113	202	2.5	7.00
105	145	20	1.1	46.5	44.8	16.4	4 300	5 100	6921	111.5	138.5	1	1.00
	160	18	1	41.9	42.2	16.5	4 100	4 800	16021	110	155	1	1.20
	160	26	2	72.3	65.8	15.8	4 000	4 700	6021	114	151	2	1.59
	190	36	2.1	133	105	14.4	3 300	3 900	6221	116	179	2	3.70
	225	49	3	184	153	13.2	2 900	3 500	6321	118	212	2.5	8.05

Single-row deep groove ball bearings open type

d 110 ~ (150) mm

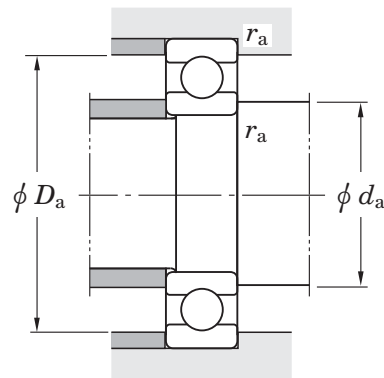
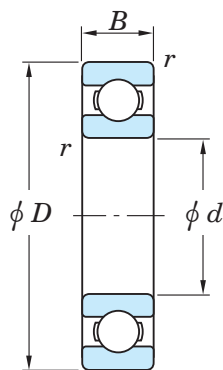

Boundary dimensions (mm)				Basic load ratings (kN)		Factor	Limiting speeds (min ⁻¹)		Bearing No.	Mounting dimensions (mm)			(Refer.) Mass (kg)
d	D	B	$r_{\min.}$	C_R	C_{0R}	f_0	Grease lub.	Oil lub.		d_a min.	D_a max.	r_a max.	
110	140	16	1	28.1	30.7	16.1	4 300	5 100	6822	115	135	1	0.606
	150	20	1.1	47.9	47.8	16.4	4 100	4 900	6922	116.5	143.5	1	1.04
	170	19	1	57.5	56.7	16.3	3 800	4 500	16022	115	165	1	1.46
	170	28	2	82.0	73.0	15.6	3 800	4 500	6022	119	161	2	1.96
	200	38	2.1	144	117	14.4	3 100	3 700	6222	121	189	2	4.36
	240	50	3	205	180	13.2	2 700	3 200	6322	123	227	2.5	9.54
120	150	16	1	29.0	33.0	16.0	4 000	4 700	6824	125	145	1	0.655
	165	22	1.1	57.2	56.9	16.4	3 800	4 400	6924	126.5	158.5	1	1.41
	180	19	1	63.2	63.3	16.4	3 600	4 200	16024	125	175	1	1.80
	180	28	2	85.0	79.3	15.9	3 600	4 200	6024	129	171	2	2.07
	215	40	2.1	155	131	14.4	2 900	3 400	6224	131	204	2	5.15
	260	55	3	207	185	13.5	2 500	3 000	6324	133	247	2.5	12.5
130	165	18	1.1	36.9	41.2	16.1	3 600	4 300	6826	136.5	158.5	1	0.939
	180	24	1.5	65.2	67.4	16.3	3 400	4 100	6926	138	172	1.5	1.86
	200	22	1.1	71.3	74.8	11.2	3 000	3 600	16026	136.5	193.5	1	2.69
	200	33	2	106	101	15.8	3 200	3 800	6026	139	191	2	3.16
	230	40	3	167	146	14.5	2 700	3 200	6226	143	217	2.5	5.82
	280	58	4	229	214	13.6	2 300	2 700	6326	146	264	3	15.1
140	175	18	1.1	38.2	44.4	16.0	3 400	4 000	6828	146.5	168.5	1	1.00
	190	24	1.5	71.3	74.8	16.5	3 200	3 800	6928	148	182	1.5	1.98
	210	22	1.1	65.8	71.1	16.5	2 900	3 400	16028	146.5	203.5	1	2.86
	210	33	2	110	109	15.9	3 000	3 600	6028	149	201	2	3.55
	250	42	3	166	150	14.8	2 400	2 900	6228	153	237	2.5	7.45
	300	62	4	253	246	13.6	2 100	2 500	6328	156	284	3	19.4
150	190	20	1.1	47.8	54.9	16.1	3 100	3 700	6830	156.5	183.5	1	1.40
	210	28	2	93.4	94.3	16.2	2 900	3 400	6930	159	201	2	3.05
	225	24	1.1	91.2	99.3	16.6	2 700	3 100	16030	156.5	218.5	1	3.58
	225	35	2.1	125	126	16.0	2 800	3 300	6030	161	214	2	4.22

[Remark] Standard cage types used for the above bearings are described earlier in this section.

d (150) ~ (200) mm

Boundary dimensions (mm)				Basic load ratings (kN)		Factor	Limiting speeds (min ⁻¹)		Bearing No.	Mounting dimensions (mm)			(Refer.) Mass (kg)
<i>d</i>	<i>D</i>	<i>B</i>	<i>r</i> _{min.}	<i>C_r</i>	<i>C_{0r}</i>	<i>f₀</i>	Grease lub.	Oil lub.		<i>d_a</i> min.	<i>D_a</i> max.	<i>r_a</i> max.	
150	270	45	3	176	168	15.1	2 200	2 700	6230	163	257	2.5	9.41
	320	65	4	275	284	13.9	1 900	2 300	6330	166	304	3	26.2
160	200	20	1.1	48.4	56.9	16.1	2 900	3 400	6832	166.5	193.5	1	1.45
	220	28	2	96.1	101	16.4	2 700	3 200	6932	169	211	2	3.20
	240	25	1.5	98.8	108	16.5	2 600	3 100	16032	168	232	1.5	4.25
	240	38	2.1	136	135	15.9	2 600	3 000	6032	171	229	2	5.22
	290	48	3	185	186	15.4	2 100	2 500	6232	173	277	2.5	14.3
	340	68	4	278	286	13.9	1 800	2 200	6332	176	324	3	29.0
170	215	22	1.1	59.8	70.5	16.1	2 700	3 200	6834	176.5	208.5	1	1.90
	230	28	2	98.8	108	16.5	2 600	3 100	6934	179	221	2	3.35
	260	28	1.5	114	127	16.5	2 300	2 700	16034	178	252	1.5	5.75
	260	42	2.1	161	161	15.8	2 400	2 800	6034	181	249	2	6.80
	310	52	4	212	223	15.3	1 900	2 300	6234	186	294	3	17.5
	360	72	4	326	355	13.6	1 700	2 000	6334	186	344	3	38.6
180	225	22	1.1	60.7	73.1	16.1	2 600	3 000	6836	186.5	218.5	1	2.00
	250	33	2	123	129	16.3	2 400	2 800	6936	189	241	2	4.90
	280	31	2	135	148	16.4	2 100	2 500	16036	189	271	2	7.55
	280	46	2.1	182	194	15.8	2 200	2 600	6036	191	269	2	10.3
	320	52	4	227	241	15.1	1 800	2 200	6236	196	304	3	18.3
	380	75	4	354	407	13.9	1 600	1 900	6336	196	364	3	44.7
190	240	24	1.5	73.1	88.1	16.1	2 400	2 800	6838	198	232	1.5	2.60
	260	33	2	126	138	16.4	2 300	2 700	6938	199	251	2	5.20
	290	31	2	139	158	16.6	2 000	2 400	16038	199	281	2	7.85
	290	46	2.1	188	201	15.8	2 100	2 500	6038	201	279	2	10.8
	340	55	4	255	281	15.0	1 700	2 000	6238	206	324	3	23.0
	400	78	5	355	415	14.1	1 500	1 800	6338	210	380	4	51.5
200	250	24	1.5	78.0	93.6	16.1	2 300	2 700	6840	208	242	1.5	2.70

Single-row deep groove ball bearings open type

d (200) ~ (280) mm

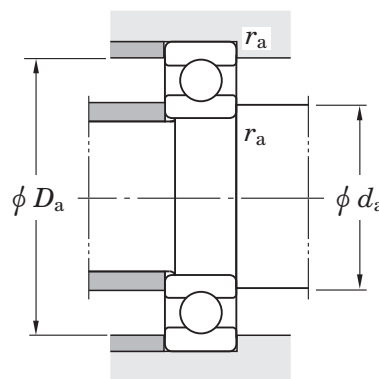
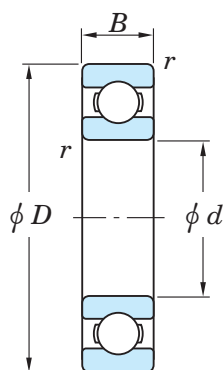

Boundary dimensions (mm)				Basic load ratings (kN)		Factor f_0	Limiting speeds (min^{-1})		Bearing No.	Mounting dimensions (mm)			(Refer.) Mass (kg)
d	D	B	$r_{\text{min.}}$	C_R	C_{0R}		Grease lub.	Oil lub.		d_a min.	D_a max.	r_a max.	
200	280	38	2.1	157	168	16.2	2 100	2 500	6940	211	269	2	7.30
	310	34	2	161	180	16.4	1 900	2 300	16040	209	301	2	10.1
	310	51	2.1	217	243	15.6	1 900	2 300	6040	211	299	2	14.0
	360	58	4	269	311	15.2	1 600	1 900	6240	216	344	3	28.2
	420	80	5	411	506	14.0	1 300	1 600	6340	220	400	4	58.0
220	270	24	1.5	80.7	101	16.0	2 000	2 400	6844	228	262	1.5	3.00
	300	38	2.1	160	180	16.4	1 900	2 200	6944	231	289	2	7.90
	340	37	2.1	180	217	16.5	1 700	2 000	16044	231	329	2	13.2
	340	56	3	235	271	15.6	1 700	2 000	6044	233	327	2.5	18.3
	400	65	4	311	376	15.1	1 400	1 700	6244	236	384	3	37.0
	460	88	5	433	539	13.8	1 200	1 500	6344	240	440	4	71.6
240	300	28	2	108	135	16.1	1 800	2 100	6848	249	291	2	4.50
	320	38	2.1	164	192	16.5	1 700	2 000	6948	251	309	2	8.50
	360	37	2.1	184	228	16.5	1 600	1 800	16048	251	349	2	14.1
	360	56	3	244	296	15.9	1 600	1 900	6048	253	347	2.5	19.7
	440	72	4	340	431	15.2	1 200	1 500	6248	256	424	3	51.0
	500	95	5	470	624	14.2	1 100	1 300	6348	260	480	4	93.3
260	320	28	2	112	146	16.0	1 700	2 000	6852	269	311	2	4.80
	360	46	2.1	213	263	16.3	1 500	1 800	6952	271	349	2	14.4
	400	44	3	236	310	16.4	1 400	1 600	16052	273	387	2.5	21.6
	400	65	4	291	377	15.8	1 400	1 700	6052	276	384	3	29.3
	480	80	5	402	541	15.1	1 100	1 300	6252	280	460	4	68.2
	540	102	6	531	741	14.2	990	1 200	6352	284	516	5	116
280	350	33	2	143	183	16.1	1 500	1 800	6856	289	341	2	7.40
	380	46	2.1	219	283	16.5	1 400	1 700	6956	291	369	2	15.1
	420	44	3	242	331	14.7	1 300	1 500	16056	293	407	2.5	22.9
	420	65	4	302	408	16.0	1 300	1 500	6056	296	404	3	31.0
	500	80	5	423	599	15.3	1 000	1 200	6256	300	480	4	71.8

[Remark] Standard cage types used for the above bearings are described earlier in this section.

d (280) ~ (380) mm

Boundary dimensions (mm)				Basic load ratings (kN)		Factor	Limiting speeds (min ⁻¹)		Bearing No.	Mounting dimensions (mm)			(Refer.) Mass (kg)
d	D	B	$r_{min.}$	C_r	C_{0r}	f_0	Grease lub.	Oil lub.		d_a min.	D_a max.	r_a max.	
280	580	108	6	568	845	14.5	880	1 100	6356	304	556	5	145
300	380	38	2.1	179	230	16.2	1 400	1 600	6860	311	369	2	10.5
	420	56	3	276	377	16.2	1 300	1 500	6960	313	407	2.5	24.1
	460	50	4	284	405	16.4	1 100	1 400	16060	316	447	3	32.2
	460	74	4	355	482	15.6	1 200	1 400	6060	316	444	3	44.0
	540	85	5	441	663	15.6	880	1 100	6260	320	520	4	89.5
	620	109	7.5	593	886	14.4	810	970	6360	332	588	6	169
320	400	38	2.1	182	239	16.1	1 300	1 500	6864	331	389	2	11.0
	440	56	3	285	404	16.4	1 200	1 400	6964	333	427	2.5	25.5
	480	50	4	292	432	16.5	1 100	1 300	16064	336	467	3	33.9
	480	74	4	352	487	15.7	1 100	1 300	6064	336	464	3	46.0
	580	92	5	489	744	15.4	840	1 000	6264	340	560	4	113
	670	112	7.5	634	1 010	14.8	720	870	6364	352	638	6	207
340	420	38	2.1	185	249	16.1	1 200	1 400	6868	351	409	2	11.5
	460	56	3	282	407	16.5	1 100	1 300	6968	353	447	2.5	26.8
	520	57	4	335	512	16.4	980	1 200	16068	356	507	3	46.8
	520	82	5	441	661	15.6	980	1 200	6068	360	500	4	61.8
	620	92	6	511	817	15.6	760	910	6268	364	596	5	131
	710	118	7.5	704	1 160	14.7	660	790	6368	372	678	6	238
360	440	38	2.1	192	268	16.0	1 100	1 300	6872	371	429	2	12.0
	480	56	3	289	432	16.5	1 000	1 200	6972	373	467	2.5	28.2
	540	57	4	345	546	16.5	900	1 100	16072	376	527	3	49.0
	540	82	5	438	668	15.7	920	1 100	6072	380	520	4	64.7
	650	95	6	557	904	15.4	700	840	6272	384	626	5	144
380	480	46	2.1	244	359	16.2	980	1 200	6876	391	469	2	20.0
	520	65	4	352	552	16.4	920	1 100	6976	396	504	3	40.8
	560	82	5	457	725	15.9	860	1 000	6076	400	540	4	67.6

Single-row deep groove ball bearings open type

d (380) ~ 500 mm

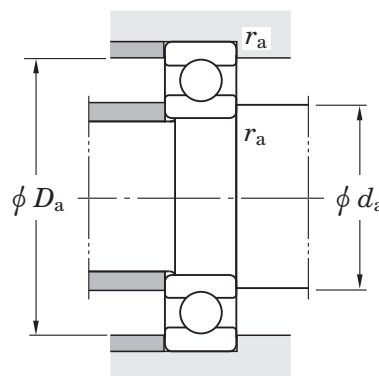
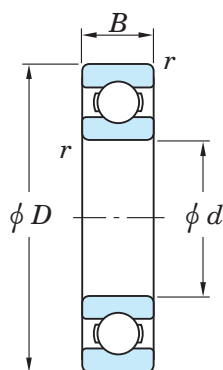

Boundary dimensions (mm)				Basic load ratings (kN)		Factor f_0	Limiting speeds (min^{-1})		Bearing No.	Mounting dimensions (mm)			(Refer.) Mass (kg)
d	D	B	$r_{\text{min.}}$	C_R	C_{0R}		Grease lub.	Oil lub.		d_a min.	D_a max.	r_a max.	
380	680	95	6	584	990	15.6	650	780	6276	404	656	5	162
400	500	46	2.1	249	374	16.1	920	1 100	6880	411	489	2	20.5
	540	65	4	362	588	16.5	860	1 000	6980	416	524	3	42.7
	600	63	5	358	587	16.5	780	920	16080	420	580	4	65.0
	600	90	5	508	824	15.7	780	920	6080	420	580	4	87.7
	720	103	6	628	1 080	15.5	590	710	6280	424	696	5	197
420	520	46	2.1	253	389	16.1	860	1 000	6884	431	509	2	21.5
	560	65	4	359	588	16.5	810	950	6984	436	544	3	43.5
	620	63	5	367	617	16.4	740	870	16084	440	600	4	69.9
	620	90	5	530	894	15.8	740	870	6084	440	600	4	91.2
440	540	46	2.1	257	404	16.0	810	950	6888	451	529	2	22.5
	600	74	4	396	676	16.4	740	870	6988	456	584	3	61.3
	650	67	5	407	710	16.5	680	810	16088	460	630	4	81.7
460	580	56	3	314	517	16.2	740	870	6892	473	567	2.5	35.0
	620	74	4	407	711	16.5	690	820	6992	476	604	3	61.7
	680	71	5	431	767	16.5	630	750	16092	480	660	4	91.2
480	600	56	3	321	539	16.1	690	820	6896	493	587	2.5	36.5
	650	78	5	432	768	16.5	640	760	6996	500	630	4	72.5
	700	71	5	444	807	16.5	600	710	16096	500	680	4	98.5
500	620	56	3	327	561	16.1	650	770	68/500	513	607	2.5	37.5
	670	78	5	444	807	16.5	610	720	69/500	520	650	4	75.2
	720	71	5	455	846	16.4	560	660	160/500	520	700	4	102
	720	100	6	600	1 100	16.0	570	670	60/500	524	696	5	128

[Remark] Standard cage types used for the above bearings are described earlier in this section.



Single-row deep groove ball bearings

shielded type

sealed type

d 10 ~ (22) mm

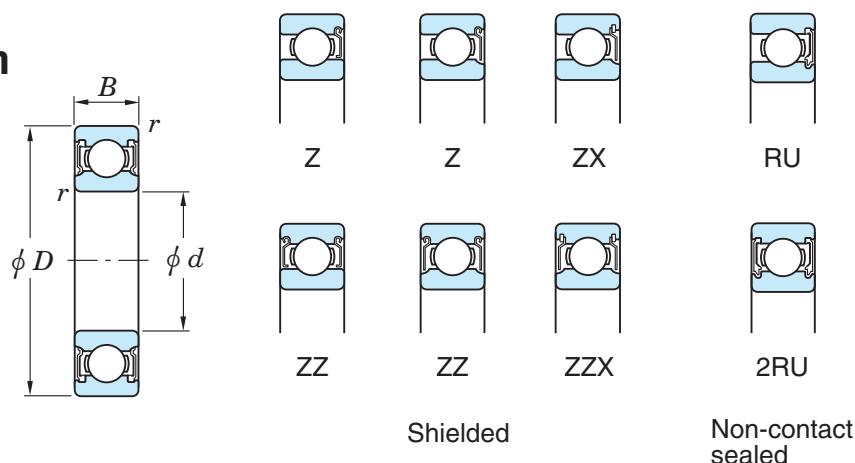

Boundary dimensions (mm)				Basic load ratings (kN)		Factor	Limiting speeds (min^{-1})				Shielded
d	D	B	$r_{\text{min.}}$	C_r	C_{0r}	f_0	Grease lub.		Oil lub.		
							[Z, ZZ] [RU, 2RU]	(RD, 2RD)	(RS, 2RS)	(Z)	
10	19	5	0.3	1.70	0.84	14.8	37 000	—	22 000	43 000	6800 ZZ
	22	6	0.3	2.70	1.25	14.0	34 000	—	21 000	41 000	6900 ZZ
	26	8	0.3	4.55	1.95	12.3	31 000	28 000	19 000	36 000	6000 ZZ
	30	9	0.6	5.10	2.40	13.2	24 000	22 000	16 000	29 000	6200 ZZ
	35	11	0.6	8.10	3.45	11.2	22 000	20 000	16 000	27 000	6300 ZZ
12	21	5	0.3	1.90	1.05	15.3	33 000	30 000	20 000	39 000	6801 ZZ
	24	6	0.3	2.90	1.45	14.5	31 000	28 000	18 000	36 000	6901 ZZ
	28	8	0.3	5.10	2.40	13.2	27 000	24 000	17 000	32 000	6001 ZZ
	32	10	0.6	6.80	3.05	12.3	22 000	20 000	15 000	27 000	6201 ZZ
	37	12	1	9.70	4.20	11.1	20 000	18 000	15 000	25 000	6301 ZZ
15	24	5	0.3	2.10	1.25	15.8	28 000	—	16 000	33 000	6802 ZZ
	28	7	0.3	4.30	2.25	14.3	26 000	23 000	15 000	30 000	6902 ZZ
	32	9	0.3	5.60	2.85	13.9	23 000	21 000	14 000	27 000	6002 ZZ
	35	11	0.6	7.65	3.75	13.2	20 000	18 000	13 000	24 000	6202 ZZ
	42	13	1	11.4	5.45	12.3	17 000	15 000	12 000	20 000	6302 ZZ
17	26	5	0.3	2.60	1.55	15.7	26 000	—	14 000	30 000	6803 ZZ
	30	7	0.3	4.60	2.55	14.7	23 000	21 000	13 000	28 000	6903 ZZ
	35	10	0.3	6.00	3.25	14.4	21 000	19 000	12 000	25 000	6003 ZZ
	40	12	0.6	9.55	4.80	13.2	17 000	15 000	12 000	21 000	6203 ZZ
	47	14	1	13.6	6.65	12.4	15 000	14 000	10 000	18 000	6303 ZZ
20	32	7	0.3	4.00	2.45	15.5	21 000	—	12 000	25 000	6804 ZZ
	37	9	0.3	6.35	3.70	14.7	19 000	17 000	11 000	23 000	6904 ZZ
	42	12	0.6	9.40	5.05	13.9	17 000	15 000	10 000	21 000	6004 ZZ
	47	14	1	12.8	6.65	13.2	15 000	14 000	9 700	17 000	6204 ZZ
	52	15	1.1	15.9	7.85	12.3	14 000	13 000	9 500	17 000	6304 ZZ
22	44	12	0.6	9.40	5.15	14.1	17 000	15 000	9 900	20 000	60/22 ZZ
	50	14	1	12.8	6.65	13.2	15 000	14 000	9 700	17 000	62/22 ZZ

[Remark] Standard cage types used for the above bearings are described earlier in this section.

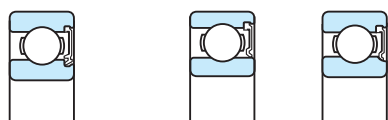

RD

RS

RS

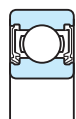

2RD

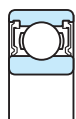

2RS

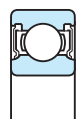

2RS

Extremely light
contact sealed

Contact sealed

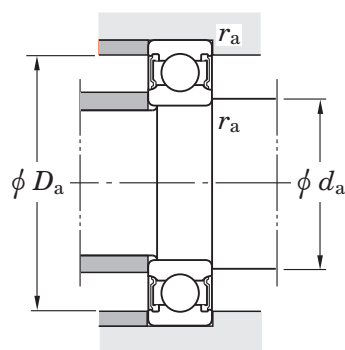

Bearing No.			Mounting dimensions. (mm)				(Refer.) Mass Open type (kg)
Non-contact sealed	Extremely light contact sealed	Contact sealed	d_a min.	d_a max.	D_a max.	r_a max.	
6800 2RU	—	6800 2RS	12	12	17	0.3	0.005
6900 2RU	—	6900 2RS	12	12.5	20	0.3	0.010
6000 2RU	6000 2RD	6000 2RS	12	13	24	0.3	0.019
6200 2RU	6200 2RD	6200 2RS	14	15	26	0.6	0.032
6300 2RU	6300 2RD	6300 2RS	14	16	31	0.6	0.053
6801 2RU	6801 2RD	6801 2RS	14	14	19	0.3	0.006
6901 2RU	6901 2RD	6901 2RS	14	14	22	0.3	0.011
6001 2RU	6001 2RD	6001 2RS	14	15	26	0.3	0.022
6201 2RU	6201 2RD	6201 2RS	16	16.5	28	0.6	0.037
6301 2RU	6301 2RD	6301 2RS	17	17.5	32	1	0.060
6802 2RU	—	6802 2RS	17	17	22	0.3	0.007
6902 2RU	6902 2RD	6902 2RS	17	18	26	0.3	0.017
6002 2RU	6002 2RD	6002 2RS	17	18.5	30	0.3	0.030
6202 2RU	6202 2RD	6202 2RS	19	19.5	31	0.6	0.045
6302 2RU	6302 2RD	6302 2RS	20	21.5	37	1	0.082
6803 2RU	—	6803 2RS	19	19	24	0.3	0.008
6903 2RU	6903 2RD	6903 2RS	19	19.5	28	0.3	0.018
6003 2RU	6003 2RD	6003 2RS	19	21	33	0.3	0.039
6203 2RU	6203 2RD	6203 2RS	21	22	36	0.6	0.065
6303 2RU	6303 2RD	6303 2RS	22	24.3	42	1	0.115
6804 2RU	—	6804 2RS	22	22.5	30	0.3	0.018
6904 2RU	6904 2RD	6904 2RS	22	23.5	35	0.3	0.036
6004 2RU	6004 2RD	6004 2RS	24	25	38	0.6	0.069
6204 2RU	6204 2RD	6204 2RS	25	26.5	42	1	0.106
6304 2RU	6304 2RD	6304 2RS	26.5	27	45.5	1	0.144
60/22 2RU	60/22 2RD	60/22 2RS	26	26.5	40	0.6	0.073
62/22 2RU	62/22 2RD	62/22 2RS	27	27	45	1	0.118

Single-row deep groove ball bearings

shielded type

sealed type

d (22) ~ 40 mm

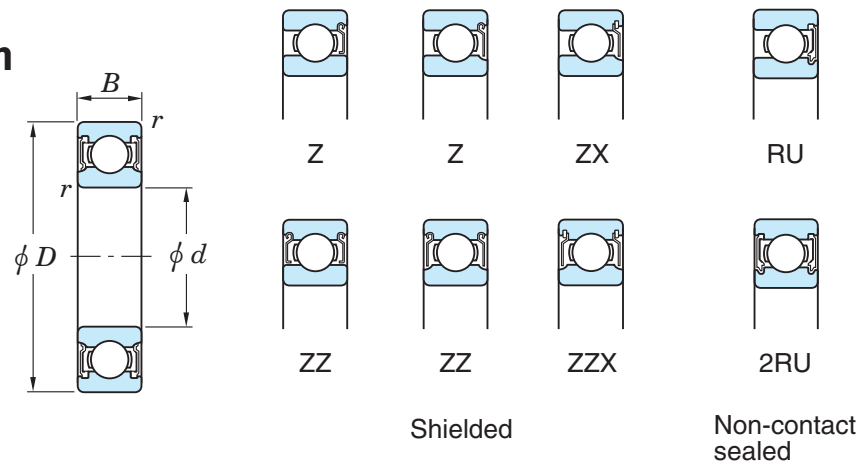

Boundary dimensions (mm)				Basic load ratings (kN)		Factor	Limiting speeds (min^{-1})				Shielded
d	D	B	$r_{\text{min.}}$	C_r	C_{0r}	f_0	Grease lub.		Oil lub.		
							$\begin{bmatrix} Z, ZZ \\ RU, 2RU \end{bmatrix}$	(RD, 2RD)	(RS, 2RS)	(Z)	
22	56	16	1.1	18.5	9.40	12.6	13 000	12 000	8 600	15 000	63/22 ZZ
25	37	7	0.3	4.30	2.95	16.0	18 000	—	10 000	21 000	6805 ZZ
	42	9	0.3	7.00	4.55	15.4	16 000	14 000	9 300	19 000	6905 ZZ
	47	12	0.6	10.1	5.85	14.5	15 000	14 000	9 000	18 000	6005 ZZ
	52	15	1	14.0	7.85	13.9	13 000	12 000	8 400	15 000	6205 ZZ
	62	17	1.1	20.6	11.3	13.2	11 000	9 900	7 500	13 000	6305 ZZ
28	52	12	0.6	12.4	7.40	14.5	14 000	13 000	8 100	16 000	60/28 ZZ
	58	16	1	17.9	9.75	13.4	12 000	11 000	7 600	14 000	62/28 ZZ
	68	18	1.1	23.5	13.1	13.3	10 000	9 000	6 900	12 000	63/28 ZZ
30	42	7	0.3	4.55	3.40	16.4	15 000	—	8 600	18 000	6806 ZZ
	47	9	0.3	7.25	5.00	15.8	14 000	13 000	8 200	17 000	6906 ZZ
	55	13	1	13.2	8.25	14.7	13 000	12 000	7 500	15 000	6006 ZZ
	62	16	1	19.5	11.3	13.9	11 000	9 900	7 000	13 000	6206 ZZ
	72	19	1.1	26.7	15.0	13.3	9 600	8 600	6 400	12 000	6306 ZZ
32	58	13	1	15.0	9.15	14.5	12 000	11 000	7 200	14 000	60/32 ZZ
	65	17	1	23.5	13.1	13.3	10 000	9 000	6 900	12 000	62/32 ZZ
	75	20	1.1	30.1	16.2	12.7	9 300	8 400	6 400	11 000	63/32 ZZ
35	47	7	0.3	4.75	3.85	16.5	13 000	—	7 400	16 000	6807 ZZ
	55	10	0.6	10.9	7.75	15.7	12 000	11 000	6 800	14 000	6907 ZZ
	62	14	1	15.9	10.3	14.9	11 000	9 900	6 500	13 000	6007 ZZ
	72	17	1.1	25.7	15.4	13.9	9 200	8 300	6 000	11 000	6207 ZZ
	80	21	1.5	33.4	19.3	13.2	8 500	7 700	5 700	10 000	6307 ZZ
40	52	7	0.3	4.95	4.20	16.3	12 000	11 000	6 700	14 000	6808 ZZ
	62	12	0.6	13.7	9.95	15.6	11 000	9 900	6 100	13 000	6908 ZZ
	68	15	1	16.7	11.5	15.2	10 000	9 000	5 800	12 000	6008 ZZ
	80	18	1.1	29.1	17.8	14.0	8 300	7 500	5 400	10 000	6208 ZZ
	90	23	1.5	40.7	24.0	13.2	7 700	6 900	5 100	9 200	6308 ZZ

[Remark] Standard cage types used for the above bearings are described earlier in this section.

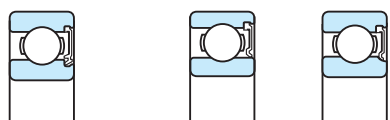

RD

RS

RS

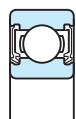

2RD

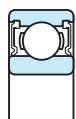

2RS

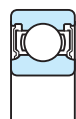

2RS

Extremely light
contact sealed

Contact sealed

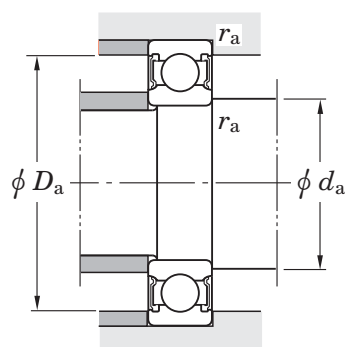

Bearing No.			Mounting dimensions. (mm)				(Refer.) Mass
Non-contact sealed	Extremely light contact sealed	Contact sealed	d_a min.	d_a max.	D_a max.	r_a max.	Open type (kg)
63/22 2RU	63/22 2RD	63/22 2RS	28.5	29	49.5	1	0.201
6805 2RU	—	6805 2RS	27	27.5	35	0.3	0.022
6905 2RU	6905 2RD	6905 2RS	27	29	40	0.3	0.041
6005 2RU	6005 2RD	6005 2RS	29	29.5	43	0.6	0.080
6205 2RU	6205 2RD	6205 2RS	30	31.5	47	1	0.128
6305 2RU	6305 2RD	6305 2RS	31.5	34	55.5	1	0.232
60/28 2RU	60/28 2RD	60/28 2RS1	32	33	48	0.6	0.097
62/28 2RU	62/28 2RD	62/28 2RS	33	35	53	1	0.173
63/28 2RU	63/28 2RD	63/28 2RS	34.5	37.5	61.5	1	0.328
6806 2RU	—	6806 2RS	32	32.5	40	0.3	0.026
6906 2RU	6906 2RD	6906 2RS	32	33	45	0.3	0.045
6006 2RU	6006 2RD	6006 2RS	35	36	50	1	0.116
6206 2RU	6206 2RD	6206 2RS	35	37.5	57	1	0.199
6306 2RU	6306 2RD	6306 2RS	36.5	40	65.5	1	0.346
60/32 2RU	60/32 2RD	60/32 2RS	37	38	53	1	0.127
62/32 2RU	62/32 2RD	62/32 2RS	37	38.5	60	1	0.228
63/32 2RU	63/32 2RD	63/32 2RS	38.5	41	68.5	1	0.437
6807 2RU	—	6807 2RS	37	37.5	45	0.3	0.030
6907 2RU	6907 2RD	6907 2RS	39	40	51	0.6	0.073
6007 2RU	6007 2RD	6007 2RS	40	42	58	1	0.155
6207 2RU	6207 2RD	6207 2RS	41.5	43.5	65.5	1	0.288
6307 2RU	6307 2RD	6307 2RS	43	46	72	1.5	0.457
6808 2RU	6808 2RD	6808 2RS	42	42	50	0.3	0.033
6908 2RU	6908 2RD	6908 2RS	44	44.5	58	0.6	0.112
6008 2RU	6008 2RD	6008 2RS	45	46.5	63	1	0.192
6208 2RU	6208 2RD	6208 2RS	46.5	49	73.5	1	0.366
6308 2RU	6308 2RD	6308 2RS	48	51.5	82	1.5	0.633

Single-row deep groove ball bearings

shielded type

sealed type

d 45 ~ (70) mm

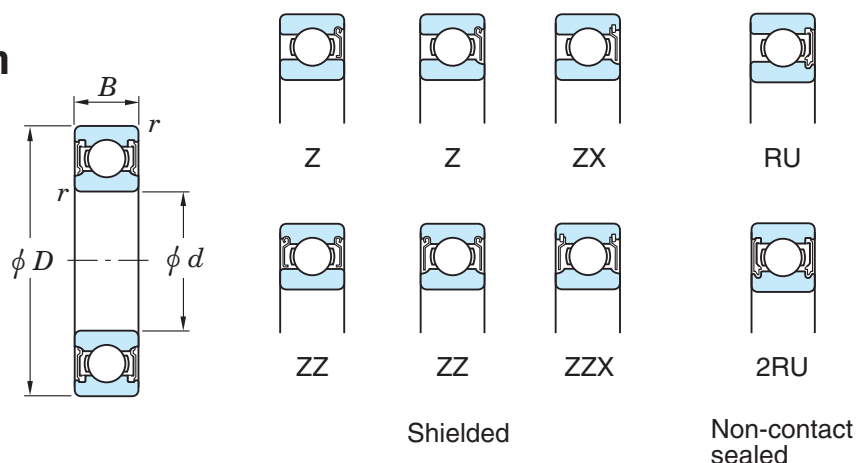

Boundary dimensions (mm)				Basic load ratings (kN)		Factor f_0	Limiting speeds (min^{-1})				Shielded
d	D	B	$r_{\text{min.}}$	C_r	C_{0r}		Grease lub.		Oil lub.		
						$\left[\begin{matrix} Z, ZZ \\ RU, 2RU \end{matrix} \right]$	(RD, 2RD)	(RS, 2RS)	(Z)		
45	58	7	0.3	6.20	5.40	16.3	11 000	9 900	5 900	13 000	6809 ZZ
	68	12	0.6	14.1	10.9	15.9	9 700	8 700	5 500	11 000	6909 ZZ
	75	16	1	21.0	15.1	15.3	9 200	8 300	5 300	11 000	6009 ZZ
	85	19	1.1	32.7	20.3	14.0	7 700	6 900	5 100	9 200	6209 ZZ
	100	25	1.5	48.9	29.5	13.3	6 800	6 100	4 500	8 100	6309 ZZ
50	65	7	0.3	6.60	6.10	16.1	9 600	8 600	5 200	11 000	6810 ZZ
	72	12	0.6	14.5	11.7	16.1	9 000	—	5 000	11 000	6910 ZZ
	80	16	1	21.8	16.6	15.6	8 400	7 600	4 800	9 900	6010 ZZ
	90	20	1.1	35.1	23.3	14.4	7 100	6 400	4 600	8 500	6210 ZZ
	110	27	2	62.0	38.3	13.2	6 100	5 500	4 100	7 300	6310 ZZ
55	72	9	0.3	8.80	8.10	16.2	8 700	7 800	—	10 000	6811 ZZ
	80	13	1	16.6	14.1	16.2	8 100	7 300	4 500	9 600	6911 ZZ
	90	18	1.1	28.3	21.2	15.3	7 600	6 800	4 300	8 900	6011 ZZ
	100	21	1.5	43.4	29.4	14.4	6 300	5 700	4 100	7 600	6211 ZZ
	120	29	2	71.6	45.0	13.2	5 600	—	3 700	6 700	6311 ZZ
60	78	10	0.3	11.5	10.6	16.3	8 000	7 200	—	9 400	6812 ZZ
	85	13	1	20.2	17.3	16.2	7 500	—	—	8 900	6912 ZZ
	95	18	1.1	29.4	23.2	15.6	7 100	—	4 000	8 400	6012 ZZ
	110	22	1.5	52.4	36.2	14.4	5 700	5 100	3 700	6 900	6212 ZZ
	130	31	2.1	81.9	52.2	13.2	5 200	—	3 500	6 200	6312 ZZ
65	85	10	0.6	11.9	11.5	16.2	7 300	6 600	—	8 600	6813 ZZ
	90	13	1	17.4	16.1	16.6	7 100	6 400	3 900	8 400	6913 ZZ
	100	18	1.1	30.5	25.2	15.8	6 600	—	3 700	7 800	6013 ZZ
	120	23	1.5	57.2	40.1	14.4	5 400	—	3 500	6 400	6213 ZZ
	140	33	2.1	92.7	59.9	13.2	4 800	—	3 200	5 800	6313 ZZ
70	90	10	0.6	12.1	11.9	16.1	6 800	6 100	—	8 100	6814 ZZ
	100	16	1	23.7	21.2	16.3	6 400	5 800	3 600	7 600	6914 ZZ

[Remark] Standard cage types used for the above bearings are described earlier in this section.

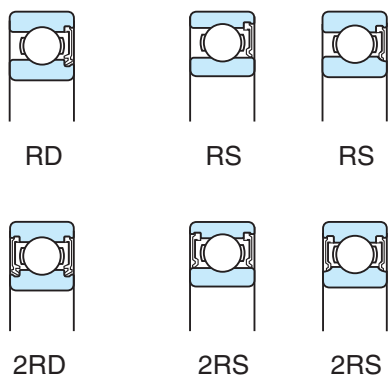

Extremely light
contact sealed

Contact sealed

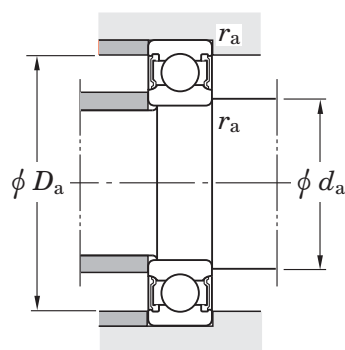

Bearing No.			Mounting dimensions. (mm)				(Refer.) Mass
Non-contact sealed	Extremely light contact sealed	Contact sealed	d_a min.	d_a max.	D_a max.	r_a max.	Open type (kg)
6809 2RU	6809 2RD	6809 2RS	47	47	56	0.3	0.040
6909 2RU	6909 2RD	6909 2RS	49	50	64	0.6	0.132
6009 2RU	6009 2RD	6009 2RS	50	51.5	70	1	0.245
6209 2RU	6209 2RD	6209 2RS	51.5	53.5	78.5	1	0.407
6309 2RU	6309 2RD	6309 2RS	53	59.5	92	1.5	0.833
6810 2RU	6810 2RD	6810 2RS	52	53	63	0.3	0.052
6910 2RU	—	—	54	55.5	68	0.6	0.133
6010 2RU	6010 2RD	6010 2RS	55	57	75	1	0.261
6210 2RU	6210 2RD	6210 2RS	56.5	59	83.5	1	0.463
6310 2RU	6310 2RD	6310 2RS	59	66.5	101	2	1.07
6811 2RU	6811 2RD	—	57	58.5	70	0.3	0.083
6911 2RU	6911 2RD	6911 2RS	60	60.5	75	1	0.185
6011 2RU	6011 2RD	6011 2RS	61.5	62	83.5	1	0.385
6211 2RU	6211 2RD	6211 2RS	63	66	92	1.5	0.607
6311 2RU	—	6311 2RS	64	74.5	111	2	1.37
6812 2RU	6812 2RD	—	62	63	76	0.3	0.104
6912 2RU	—	—	65	66	80	1	0.192
6012 2RU	—	6012 2RS	66.5	68.5	88.5	1	0.415
6212 2RU	6212 2RD	6212 2RS	68	72.5	102	1.5	0.783
6312 2RU	—	6312 2RS	71	80	119	2	1.70
6813 2RU	6813 2RD	—	69	69	81	0.6	0.126
6913 2RU	6913 2RD	6913 2RS	70	71	85	1	0.211
6013 2RU	—	6013 2RS	71.5	74.5	93.5	1	0.435
6213 2RU	—	6213 2RS	73	79	112	1.5	0.990
6313 2RU	—	6313 2RS	76	86	129	2	2.08
6814 2RU	6814 2RD	—	74	74	86	0.6	0.134
6914 2RU	6914 2RD	6914 2RS	75	76.5	95	1	0.342

Single-row deep groove ball bearings

shielded type

sealed type

d (70) ~ 95 mm

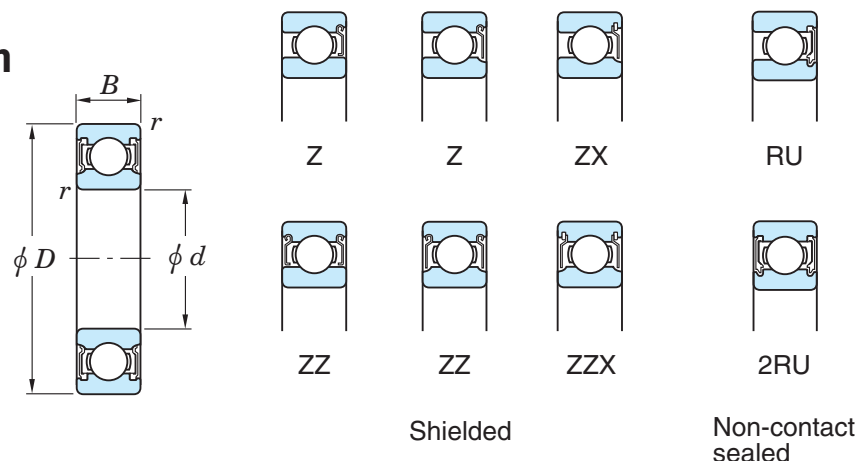

Boundary dimensions (mm)				Basic load ratings (kN)		Factor f_0	Limiting speeds (min^{-1})				Shielded
d	D	B	$r_{\text{min.}}$	C_r	C_{0r}		Grease lub.		Oil lub.		
						$\left[\begin{matrix} Z, ZZ \\ RU, 2RU \end{matrix} \right]$	(RD, 2RD)	(RS, 2RS)	(Z)		
70	110	20	1.1	38.1	30.9	15.6	6 100	—	3 500	7 200	6014 ZZ
	125	24	1.5	62.2	44.1	14.5	5 100	—	3 300	6 100	6214 ZZ
	150	35	2.1	104	68.2	13.2	4 500	—	3 000	5 400	6314 ZZ
75	95	10	0.6	12.5	12.9	16.0	6 400	5 800	—	7 600	6815 ZZ
	105	16	1	24.4	22.6	16.5	6 100	—	—	7 200	6915 ZZ
	115	20	1.1	39.6	33.5	15.8	5 700	—	3 300	6 800	6015 ZZ
	130	25	1.5	67.4	48.3	14.5	4 800	—	3 100	5 800	6215 ZZ
	160	37	2.1	113	77.2	13.2	4 200	—	2 800	5 000	6315 ZZ
80	100	10	0.6	12.7	13.3	16.0	6 100	5 500	—	7 200	6816 ZZ
	110	16	1	25.0	24.0	16.6	5 700	5 100	3 200	6 800	6916 ZZ
	125	22	1.1	47.6	39.8	15.6	5 300	—	3 100	6 300	6016 ZZ
	140	26	2	72.7	53.0	14.6	4 500	—	2 900	5 400	6216 ZZ
	170	39	2.1	123	86.7	13.3	3 900	—	2 700	4 700	6316 ZZ
85	110	13	1	18.7	19.0	16.2	5 600	5 000	—	6 600	6817 ZZ
	120	18	1.1	31.9	29.6	16.4	5 300	4 800	3 000	6 300	6917 ZZ
	130	22	1.1	49.5	43.1	15.8	5 000	—	2 900	5 900	6017 ZZ
	150	28	2	84.0	61.9	14.5	4 200	—	2 700	5 000	6217 ZZ
	180	41	3	133	96.8	13.3	3 700	—	2 500	4 400	6317 ZZ
90	115	13	1	19.0	19.7	16.1	5 300	4 800	—	6 300	6818 ZZ
	125	18	1.1	32.8	31.6	16.5	5 100	4 600	2 800	6 000	6918 ZZ
	140	24	1.5	58.2	49.7	15.6	4 700	—	2 700	5 600	6018 ZZ
	160	30	2	96.1	71.5	14.5	3 900	—	2 600	4 700	6218 ZZ
	190	43	3	143	107	13.3	3 500	—	2 400	4 200	6318 ZZ
95	130	18	1.1	33.7	33.5	16.6	4 800	4 300	2 700	5 700	6919 ZZ
	145	24	1.5	60.4	53.9	15.8	4 400	—	2 500	5 200	6019 ZZ
	170	32	2.1	109	81.9	14.4	3 700	—	2 400	4 400	6219 ZZ
	200	45	3	153	119	13.3	3 300	—	2 200	4 000	6319 ZZ

[Remark] Standard cage types used for the above bearings are described earlier in this section.

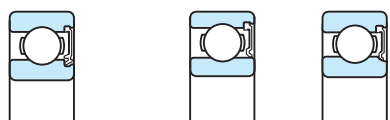

RD

RS

RS

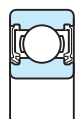

2RD

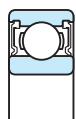

2RS

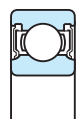

2RS

Extremely light
contact sealed

Contact sealed

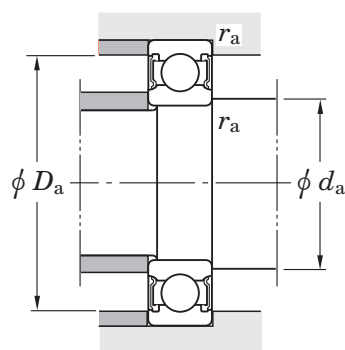

Bearing No.			Mounting dimensions. (mm)				(Refer.) Mass Open type (kg)
Non-contact sealed	Extremely light contact sealed	Contact sealed	d_a min.	d_a max.	D_a max.	r_a max.	
6014 2RU	—	6014 2RS	76.5	79.5	103.5	1	0.602
6214 2RU	—	6214 2RS	78	84	117	1.5	1.07
6314 2RU	—	6314 2RS	81	92	139	2	2.52
6815 2RU	6815 2RD	—	79	79	91	0.6	0.142
6915 2RU	—	—	80	82.5	100	1	0.363
6015 2RU	—	6015 2RS	81.5	84.5	108.5	1	0.638
6215 2RU	—	6215 2RS	83	88.5	122	1.5	1.18
6315 2RU	—	6315 2RS	86	97.5	149	2	3.02
6816 2RU	6816 2RD	—	84	84	96	0.6	0.150
6916 2RU	6916 2RD	6916 2RS	85	86.5	105	1	0.382
6016 2RU	—	6016 2RS	86.5	90	118.5	1	0.850
6216 2RU	—	6216 2RS	89	93	131	2	1.40
6316 2RU	—	6316 2RS	91	105	159	2	3.59
6817 2RU	6817 2RD	—	90	90.5	105	1	0.266
6917 2RU	6917 2RD	6917 2RS	91.5	92.5	113.5	1	0.535
6017 2RU	—	6017 2RS	91.5	96.5	123.5	1	0.890
6217 2RU	—	6217 2RS	94	102	141	2	1.79
6317 2RU	—	6317 2RS	98	111	167	2.5	4.23
6818 2RU	6818 2RD	—	95	95.5	110	1	0.279
6918 2RU	6918 2RD	6918 2RS	96.5	97.5	118.5	1	0.565
6018 2RU	—	6018 2RS	98	100.5	132	1.5	1.16
6218 2RU	—	6218 2RS	99	108.5	151	2	2.15
6318 2RU	—	6318 2RS	103	117	177	2.5	4.91
6919 2RU	6919 2RD	6919 2RS	101.5	102	123.5	1	0.705
6019 2RU	—	6019 2RS	103	107.5	137	1.5	1.21
6219 2RU	—	6219 2RS	106	113	159	2	2.62
6319 2RU	—	6319 2RS	108	122	187	2.5	5.67

Single-row deep groove ball bearings

shielded type

sealed type

d 100 ~ (140) mm

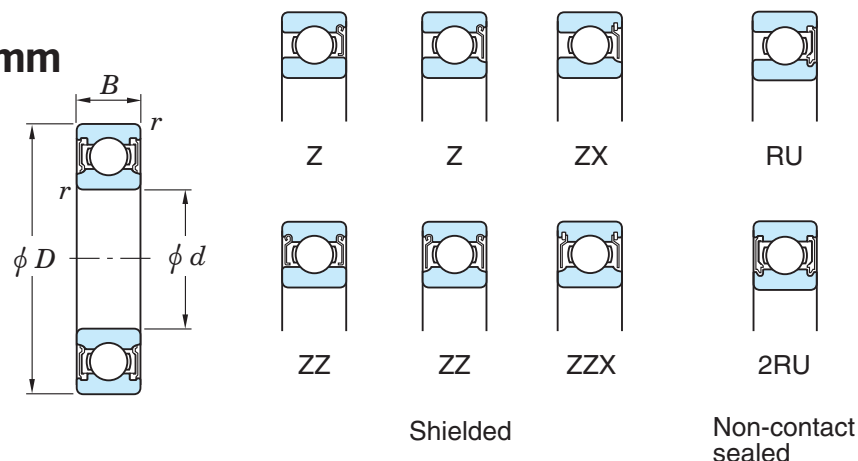

Boundary dimensions (mm)				Basic load ratings (kN)		Factor f_0	Limiting speeds (min^{-1})				Shielded
d	D	B	$r_{\text{min.}}$	C_r	C_{0r}		Grease lub.		Oil lub.		
						$\left[\begin{matrix} Z, ZZ \\ RU, 2RU \end{matrix} \right]$	(RD, 2RD)	(RS, 2RS)	(Z)		
100	125	13	1	19.6	21.2	16.0	4 800	4 300	—	5 700	6820 ZZ
	140	20	1.1	45.0	41.9	16.2	4 500	—	—	5 300	6920-1 ZZ
	150	24	1.5	60.2	54.2	15.9	4 300	—	2 500	5 100	6020 ZZ
	180	34	2.1	122	93.1	14.4	3 500	—	2 300	4 200	6220 ZZ
	215	47	3	173	141	13.2	3 000	—	2 100	3 600	6320 ZZ
105	145	20	1.1	46.5	44.8	16.4	4 300	—	2 400	5 100	6921-1 ZZ
	160	26	2	72.3	65.8	15.8	4 000	—	2 300	4 700	6021 ZZ
	190	36	2.1	133	105	14.4	3 300	—	2 200	3 900	6221 ZZ
	225	49	3	184	153	13.2	2 900	—	2 000	3 500	6321 ZZ
110	140	16	1	28.1	30.7	16.1	4 300	3 900	—	5 100	6822 ZZ
	150	20	1.1	47.9	47.8	16.4	4 100	—	—	4 900	6922 ZZ
	170	28	2	82.0	73.0	15.6	3 800	—	2 200	4 500	6022 ZZ
	200	38	2.1	144	117	14.4	3 100	—	2 000	3 700	6222 ZZ
	240	50	3	205	180	13.2	2 700	—	1 900	3 200	6322 ZZ
120	150	16	1	29.0	33.0	16.0	4 000	—	—	4 700	6824 ZZ
	165	22	1.1	57.2	56.9	16.4	3 800	—	—	4 400	6924 ZZ
	180	28	2	85.0	79.3	15.9	3 600	—	2 100	4 200	6024 ZZ
	215	40	2.1	155	131	14.4	2 900	—	1 900	3 400	6224 ZZ
	260	55	3	207	185	13.5	2 500	—	—	3 000	6324 ZZ
130	165	18	1.1	36.9	41.2	16.1	3 600	—	—	4 300	6826 ZZ
	180	24	1.5	65.2	67.4	16.3	3 400	—	—	4 100	6926-1 ZZ
	200	33	2	106	101	15.8	3 200	—	1 900	3 800	6026 ZZ
	230	40	3	167	146	14.5	2 700	—	1 800	3 200	6226 ZZ
	280	58	4	229	214	13.6	2 300	—	—	2 700	6326 ZZ
140	175	18	1.1	38.2	44.4	16.0	3 400	3 100	—	4 000	6828 ZZ
	190	24	1.5	71.3	74.8	16.5	3 200	—	—	3 800	6928-1 ZZ
	210	33	2	110	109	15.9	3 000	—	1 800	3 600	6028 ZZ

[Remark] Standard cage types used for the above bearings are described earlier in this section.

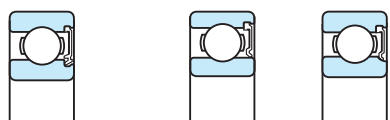

RD

RS

RS

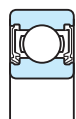

2RD

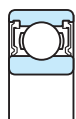

2RS

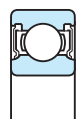

2RS

Extremely light
contact sealed

Contact sealed

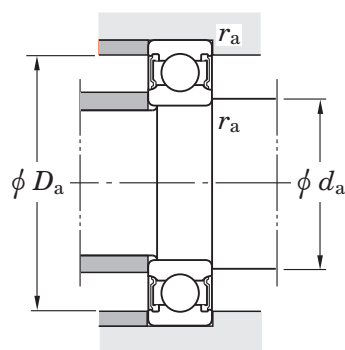

Bearing No.			Mounting dimensions. (mm)				(Refer.) Mass
Non-contact sealed	Extremely light contact sealed	Contact sealed	d_a min.	d_a max.	D_a max.	r_a max.	Open type (kg)
6820 2RU	6820 2RD	—	105	105.5	120	1	0.309
6920-1 2RU	—	—	106.5	110.5	133.5	1	0.960
6020 2RU	—	6020 2RS	108	112	142	1.5	1.25
6220 2RU	—	6220 2RS	111	122	169	2	3.14
6320 2RU	—	6320 2RS	113	131	202	2.5	7.00
6921-1 2RU	—	6921-1 2RS	111.5	115	138.5	1	1.00
6021 2RU	—	6021 2RS	114	119	151	2	1.59
6221 2RU	—	6221 2RS	116	127	179	2	3.70
6321 2RU	—	6321 2RS	118	136	212	2.5	8.05
6822 2RU	6822 2RD	—	115	116.5	135	1	0.606
6922 2RU	—	—	116.5	119.5	143.5	1	1.04
6022 2RU	—	6022 2RS	119	123	161	2	1.96
6222 2RU	—	6222 2RS	121	136.5	189	2	4.36
6322 2RU	—	6322 2RS	123	146.5	227	2.5	9.54
6824 2RU	—	—	125	128.5	145	1	0.655
6924 2RU	—	—	126.5	131.5	158.5	1	1.41
6024 2RU	—	6024 2RS	129	136	171	2	2.07
6224 2RU	—	6224 2RS	131	144	204	2	5.15
—	—	—	133	158	247	2.5	12.5
6826 2RU	—	—	136.5	139.5	158.5	1	0.939
6926-1 2RU	—	—	138	144	172	1.5	1.86
6026 2RU	—	6026 2RS	139	146.5	191	2	3.16
6226 2RU	—	6226 2RS	143	157	217	2.5	5.82
—	—	—	146	171	264	3	15.1
—	6828 2RD	—	146.5	148	168.5	1	1.00
6928-1 2RU	—	—	148	153	182	1.5	1.98
6028 2RU	—	6028 2RS	149	158.5	201	2	3.55

Single-row deep groove ball bearings

shielded type

sealed type

d (140) ~ 220 mm

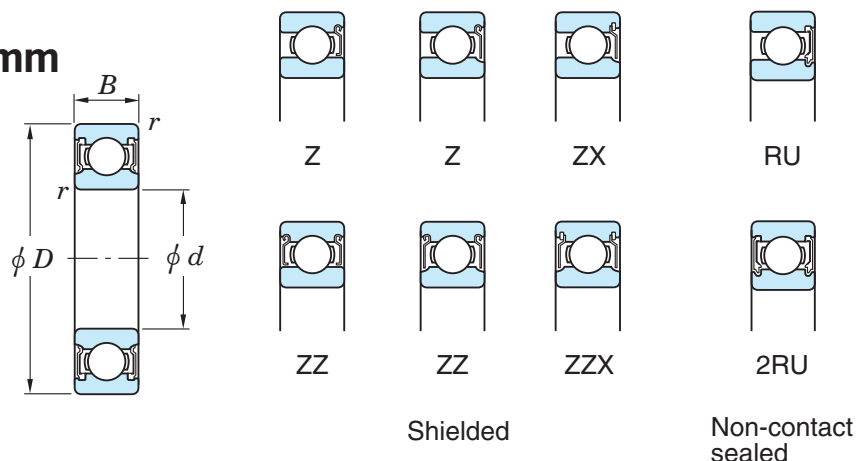

Boundary dimensions (mm)				Basic load ratings (kN)		Factor	Limiting speeds (min^{-1})				Shielded
d	D	B	$r_{\text{min.}}$	C_r	C_{0r}	f_0	Grease lub.		Oil lub.		
							(Z, ZZ) (RU, 2RU)	(RD, 2RD)	(RS, 2RS)	(Z)	
140	250	42	3	166	150	14.8	2 400	—	1 600	2 900	6228 ZZ 6328 ZZ
	300	62	4	253	246	13.6	2 100	—	—	2 500	
150	210	28	2	93.4	94.3	16.2	2 900	—	1 700	3 400	6930 ZZ 6030 ZZ 6230 ZZ
	225	35	2.1	125	126	16.0	2 800	—	1 600	3 300	
	270	45	3	176	168	15.1	2 200	—	—	2 700	
160	200	20	1.1	48.4	56.9	16.1	2 900	2 600	—	3 400	6832 ZZ 6032 ZZ 6232 ZZ
	240	38	2.1	136	135	15.9	2 600	—	1 500	3 000	
	290	48	3	185	186	15.4	2 100	—	—	2 500	
170	215	22	1.1	59.8	70.5	16.1	2 700	—	—	3 200	6834 ZZ 6034 ZZ 6234 ZZ
	260	42	2.1	161	161	15.8	2 400	—	—	2 800	
	310	52	4	212	223	15.3	1 900	—	—	2 300	
180	225	22	1.1	60.7	73.1	16.1	2 600	2 300	—	3 000	6836 ZZ 6036 ZZ 6236-1 ZZ
	280	46	2.1	182	194	15.8	2 200	—	—	2 600	
	320	52	4	227	241	15.1	1 800	—	—	2 200	
190	240	24	1.5	73.1	88.1	16.1	2 400	—	—	2 800	6838 ZZ 6038 ZZ
	290	46	2.1	188	201	15.8	2 100	—	—	2 500	
200	310	51	2.1	217	243	15.6	1 900	—	—	2 300	6040 ZZ 6240-1 ZZ
	360	58	4	269	311	15.2	1 600	—	—	1 900	
220	340	56	3	235	271	15.6	1 700	—	—	2 000	6044 ZZ

[Remark] Standard cage types used for the above bearings are described earlier in this section.

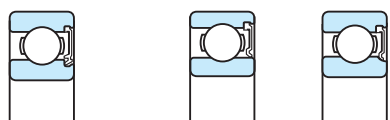

RD

RS

RS

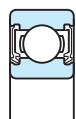

2RD

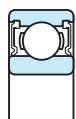

2RS

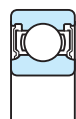

2RS

Extremely light
contact sealed

Contact sealed

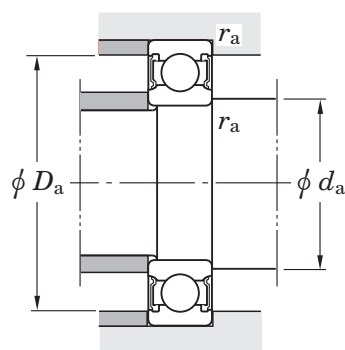

Bearing No.			Mounting dimensions. (mm)				(Refer.) Mass
Non-contact sealed	Extremely light contact sealed	Contact sealed	d_a min.	d_a max.	D_a max.	r_a max.	Open type (kg)
6228 2RU	—	6228 2RS	153	169	237	2.5	7.45
—	—	—	156	184	284	3	19.4
6930 2RU	—	6930 2RS	159	165.5	201	2	3.05
6030 2RU	—	6030 2RS	161	168.5	214	2	4.22
—	—	—	163	183.5	257	2.5	9.41
—	6832 2RD	—	166.5	168.5	193.5	1	1.45
6032 2RU	—	6032 2RS	171	178.5	229	2	5.22
—	—	—	173	198	277	2.5	14.3
—	—	—	176.5	182.5	208.5	1	1.90
6034 2RU	—	—	181	194	249	2	6.80
—	—	—	186	210.5	294	3	17.5
—	6836 2RD	—	186.5	189.5	218.5	1	2.00
6036 2RU	—	—	191	209.5	269	2	10.3
—	—	—	196	220.5	304	3	18.3
—	—	—	198	202	232	1.5	2.60
—	—	—	201	215	279	2	10.8
—	—	—	211	228	299	2	14.0
—	—	—	216	250	344	3	28.2
—	—	—	233	251	327	2.5	18.3

Single-row deep groove ball bearings

snap ring groove type

locating snap ring type

d 10 ~ 32 mm

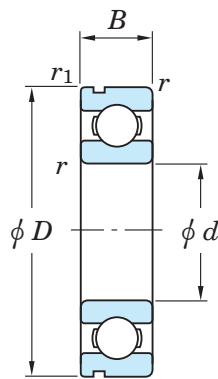

N
With snap ring groove

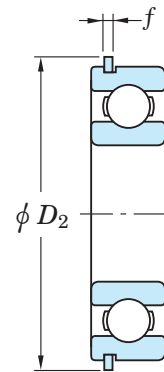

NR
With locating snap ring

Boundary dimensions (mm)					Basic load ratings (kN)		Factor	Limiting speeds (min ⁻¹)		Bearing No.		D_1 max.
d	D	B	r min.	r_1 min.	C_r	C_{Or}	f_0	Grease lub.	Oil lub.	With snap ring groove	With locating snap ring	
10	30	9	0.6	0.3	5.10	2.40	13.2	24 000	29 000	6200N	6200NR	28.17
	35	11	0.6	0.5	8.10	3.45	11.2	22 000	27 000	6300N	6300NR	33.17
12	32	10	0.6	0.3	6.80	3.05	12.3	22 000	27 000	6201N	6201NR	30.15
	37	12	1	0.5	9.70	4.20	11.1	20 000	25 000	6301N	6301NR	34.77
15	35	11	0.6	0.5	7.65	3.75	13.2	20 000	24 000	6202N	6202NR	33.17
	42	13	1	0.5	11.4	5.45	12.3	17 000	20 000	6302N	6302NR	39.75
17	40	12	0.6	0.5	9.55	4.80	13.2	17 000	21 000	6203N	6203NR	38.1
	47	14	1	0.5	13.6	6.65	12.4	15 000	18 000	6303N	6303NR	44.6
20	42	12	0.6	0.5	9.40	5.05	13.9	17 000	21 000	6004N	6004NR	39.75
	47	14	1	0.5	12.8	6.65	13.2	15 000	17 000	6204N	6204NR	44.6
	52	15	1.1	0.5	15.9	7.85	12.3	14 000	17 000	6304N	6304NR	49.73
22	44	12	0.6	0.5	9.40	5.15	14.1	17 000	20 000	60/22N	60/22NR	41.75
	50	14	1	0.5	12.8	6.65	13.2	15 000	17 000	62/22N	62/22NR	47.6
	56	16	1.1	0.5	18.5	9.40	12.6	13 000	15 000	63/22N	63/22NR	53.6
25	47	12	0.6	0.5	10.1	5.85	14.5	15 000	18 000	6005N	6005NR	44.6
	52	15	1	0.5	14.0	7.85	13.9	13 000	15 000	6205N	6205NR	49.73
	62	17	1.1	0.5	20.6	11.3	13.2	11 000	13 000	6305N	6305NR	59.61
28	52	12	0.6	0.5	12.4	7.40	14.5	14 000	16 000	60/28N	60/28NR	49.73
	58	16	1	0.5	17.9	9.75	13.4	12 000	14 000	62/28N	62/28NR	55.6
	68	18	1.1	0.5	23.5	13.1	13.3	10 000	12 000	63/28N	63/28NR	64.82
30	55	13	1	0.5	13.2	8.25	14.7	13 000	15 000	6006N	6006NR	52.6
	62	16	1	0.5	19.5	11.3	13.9	11 000	13 000	6206N	6206NR	59.61
	72	19	1.1	0.5	26.7	15.0	13.3	9 600	12 000	6306N	6306NR	68.81
32	58	13	1	0.5	15.0	9.15	14.5	12 000	14 000	60/32N	60/32NR	55.6
	65	17	1	0.5	23.5	13.1	13.3	10 000	12 000	62/32N	62/32NR	62.6
	75	20	1.1	0.5	30.1	16.2	12.7	9 300	11 000	63/32N	63/32NR	71.83

[Remark] Standard cage types used for the above bearings are described earlier in this section.

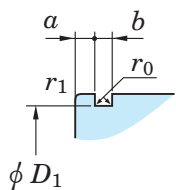

Snap ring groove details

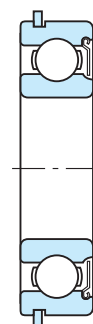
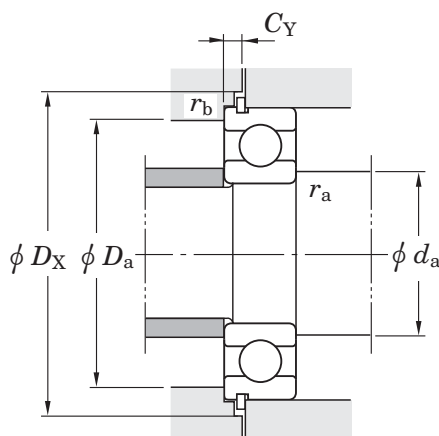

With locating snap ring and one shield

Dimensions of snap ring groove (mm)			Dimensions of locating snap ring (mm)		Mounting dimensions (mm)						(Refer.) Mass (kg)	(Refer.) Bearing No.
a	b	r ₀	D ₂	f	d _a	D _a	D _X	C _Y	r _a	r _b		
max.	±0.15	max.	max.	±0.05	min.	max.	min.	max.	max.	max.		
2.06	1.5	0.4	34.7	1.07	14	26	35.5	2.92	0.6	0.3	0.032	6200N
2.06	1.5	0.4	39.7	1.07	14	31	40.5	2.92	0.6	0.5	0.053	6300N
2.06	1.5	0.4	36.7	1.07	16	28	37.5	2.92	0.6	0.3	0.037	6201N
2.06	1.5	0.4	41.3	1.07	17	32	42	2.92	1	0.5	0.060	6301N
2.06	1.5	0.4	39.7	1.07	19	31	40.5	2.92	0.6	0.5	0.045	6202N
2.06	1.5	0.4	46.3	1.07	20	37	47	2.92	1	0.5	0.082	6302N
2.06	1.5	0.4	44.6	1.07	21	36	45.5	2.92	0.6	0.5	0.065	6203N
2.46	1.5	0.4	52.7	1.07	22	42	53.5	3.33	1	0.5	0.115	6303N
2.06	1.5	0.4	46.3	1.07	24	38	47	2.92	0.6	0.5	0.069	6004N
2.46	1.5	0.4	52.7	1.07	25	42	53.5	3.33	1	0.5	0.106	6204N
2.46	1.5	0.4	57.9	1.07	26.5	45.5	58.5	3.33	1	0.5	0.144	6304N
2.06	1.5	0.4	48.3	1.07	26	40	49	2.92	0.6	0.5	0.073	60/22N
2.46	1.5	0.4	55.7	1.07	27	45	56.5	3.33	1	0.5	0.118	62/22N
2.46	1.5	0.4	61.7	1.07	28.5	49.5	62.5	3.33	1	0.5	0.201	63/22N
2.06	1.5	0.4	52.7	1.07	29	43	53.5	2.92	0.6	0.5	0.080	6005N
2.46	1.5	0.4	57.9	1.07	30	47	58.5	3.33	1	0.5	0.128	6205N
3.28	2.05	0.6	67.7	1.65	31.5	55.5	68.5	4.67	1	0.5	0.232	6305N
2.06	1.5	0.4	57.9	1.07	32	48	58.5	2.92	0.6	0.5	0.097	60/28N
2.46	1.5	0.4	63.7	1.07	33	53	64.5	3.33	1	0.5	0.173	62/28N
3.28	2.05	0.6	74.6	1.65	34.5	61.5	76	4.67	1	0.5	0.328	63/28N
2.08	1.5	0.4	60.7	1.07	35	50	61.5	2.9	1	0.5	0.116	6006N
3.28	2.05	0.6	67.7	1.65	35	57	68.5	4.67	1	0.5	0.199	6206N
3.28	2.05	0.6	78.6	1.65	36.5	65.5	80	4.67	1	0.5	0.346	6306N
2.08	1.5	0.4	63.7	1.07	37	53	64.5	2.9	1	0.5	0.127	60/32N
3.28	2.05	0.6	70.7	1.65	37	60	71.5	4.67	1	0.5	0.228	62/32N
3.28	2.05	0.6	81.6	1.65	38.5	68.5	83	4.67	1	0.5	0.437	63/32N

Single-row deep groove ball bearings

snap ring groove type

locating snap ring type

d 35 ~ 75 mm

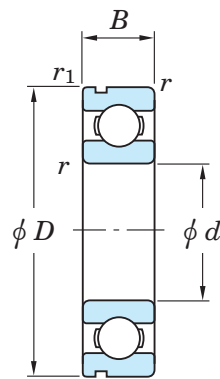

N
With snap ring groove

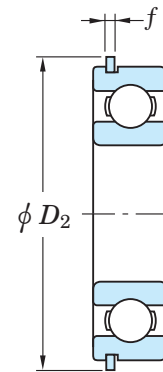

NR
With locating snap ring

Boundary dimensions (mm)					Basic load ratings (kN)		Factor	Limiting speeds (min ⁻¹)		Bearing No.		D_1 max.
d	D	B	r min.	r_1 min.	C_r	C_{Or}	f_0	Grease lub.	Oil lub.	With snap ring groove	With locating snap ring	
35	62	14	1	0.5	15.9	10.3	14.9	11 000	13 000	6007N	6007NR	59.61
	72	17	1.1	0.5	25.7	15.4	13.9	9 200	11 000	6207N	6207NR	68.81
	80	21	1.5	0.5	33.4	19.3	13.2	8 500	10 000	6307N	6307NR	76.81
40	68	15	1	0.5	16.7	11.5	15.2	10 000	12 000	6008N	6008NR	64.82
	80	18	1.1	0.5	29.1	17.8	14.0	8 300	10 000	6208N	6208NR	76.81
	90	23	1.5	0.5	40.7	24.0	13.2	7 700	9 200	6308N	6308NR	86.79
45	75	16	1	0.5	21.0	15.1	15.3	9 200	11 000	6009N	6009NR	71.83
	85	19	1.1	0.5	32.7	20.3	14.0	7 700	9 200	6209N	6209NR	81.81
	100	25	1.5	0.5	48.9	29.5	13.3	6 800	8 100	6309N	6309NR	96.8
50	80	16	1	0.5	21.8	16.6	15.6	8 400	9 900	6010N	6010NR	76.81
	90	20	1.1	0.5	35.1	23.3	14.4	7 100	8 500	6210N	6210NR	86.79
	110	27	2	0.5	62.0	38.3	13.2	6 100	7 300	6310N	6310NR	106.81
55	90	18	1.1	0.5	28.3	21.2	15.3	7 600	8 900	6011N	6011NR	86.79
	100	21	1.5	0.5	43.4	29.4	14.4	6 300	7 600	6211N	6211NR	96.8
	120	29	2	0.5	71.6	45.0	13.2	5 600	6 700	6311N	6311NR	115.21
60	95	18	1.1	0.5	29.4	23.2	15.6	7 100	8 400	6012N	6012NR	91.82
	110	22	1.5	0.5	52.4	36.2	14.4	5 700	6 900	6212N	6212NR	106.81
	130	31	2.1	0.5	81.9	52.2	13.2	5 200	6 200	6312N	6312NR	125.22
65	100	18	1.1	0.5	30.5	25.2	15.8	6 600	7 800	6013N	6013NR	96.8
	120	23	1.5	0.5	57.2	40.1	14.4	5 400	6 400	6213N	6213NR	115.21
	140	33	2.1	0.5	92.7	59.9	13.2	4 800	5 800	6313N	6313NR	135.23
70	110	20	1.1	0.5	38.1	30.9	15.6	6 100	7 200	6014N	6014NR	106.81
	125	24	1.5	0.5	62.2	44.1	14.5	5 100	6 100	6214N	6214NR	120.22
	150	35	2.1	0.5	104	68.2	13.2	4 500	5 400	6314N	6314NR	145.24
75	115	20	1.1	0.5	39.6	33.5	15.8	5 700	6 800	6015N	6015NR	111.81
	130	25	1.5	0.5	67.4	48.3	14.5	4 800	5 800	6215N	6215NR	125.22
	160	37	2.1	0.5	113	77.2	13.2	4 200	5 000	6315N	6315NR	155.22

[Remark] Standard cage types used for the above bearings are described earlier in this section.

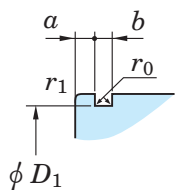

Snap ring groove details

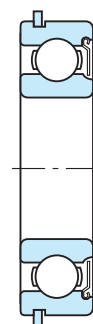
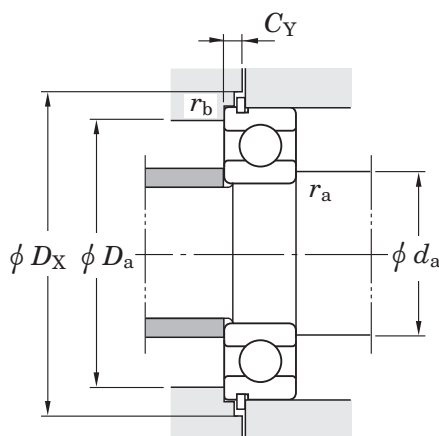

With locating snap ring and one shield

Dimensions of snap ring groove (mm)			Dimensions of locating snap ring (mm)		Mounting dimensions (mm)						(Refer.) Mass (kg)	(Refer.) Bearing No.
<i>a</i>	<i>b</i>	<i>r</i> ₀	<i>D</i> ₂	<i>f</i>	<i>d</i> _a	<i>D</i> _a	<i>D</i> _X	<i>C</i> _Y	<i>r</i> _a	<i>r</i> _b		
max.	±0.15	max.	max.	±0.05	min.	max.	min.	max.	max.	max.		
2.08	2.05	0.6	67.7	1.65	40	58	68.5	3.48	1	0.5	0.155	6007N
3.28	2.05	0.6	78.6	1.65	41.5	65.5	80	4.67	1	0.5	0.288	6207N
3.28	2.05	0.6	86.6	1.65	43	72	88	4.67	1.5	0.5	0.457	6307N
2.49	2.05	0.6	74.6	1.65	45	63	76	3.89	1	0.5	0.192	6008N
3.28	2.05	0.6	86.6	1.65	46.5	73.5	88	4.67	1	0.5	0.366	6208N
3.28	2.85	0.6	96.5	2.41	48	82	98	5.43	1.5	0.5	0.633	6308N
2.49	2.05	0.6	81.6	1.65	50	70	83	3.89	1	0.5	0.245	6009N
3.28	2.05	0.6	91.6	1.65	51.5	78.5	93	4.67	1	0.5	0.407	6209N
3.28	2.85	0.6	106.5	2.41	53	92	108	5.43	1.5	0.5	0.833	6309N
2.49	2.05	0.6	86.6	1.65	55	75	88	3.89	1	0.5	0.261	6010N
3.28	2.85	0.6	96.5	2.41	56.5	83.5	98	5.43	1	0.5	0.463	6210N
3.28	2.85	0.6	116.6	2.41	59	101	118	5.43	2	0.5	1.07	6310N
2.87	2.85	0.6	96.5	2.41	61.5	83.5	98	5.03	1	0.5	0.385	6011N
3.28	2.85	0.6	106.5	2.41	63	92	108	5.43	1.5	0.5	0.607	6211N
4.06	3.25	0.6	129.7	2.77	64	111	131.5	6.58	2	0.5	1.37	6311N
2.87	2.85	0.6	101.6	2.41	66.5	88.5	103	5.03	1	0.5	0.415	6012N
3.28	2.85	0.6	116.6	2.41	68	102	118	5.43	1.5	0.5	0.783	6212N
4.06	3.25	0.6	139.7	2.77	71	119	141.5	6.58	2	0.5	1.70	6312N
2.87	2.85	0.6	106.5	2.41	71.5	93.5	108	5.03	1	0.5	0.435	6013N
4.06	3.25	0.6	129.7	2.77	73	112	131.5	6.58	1.5	0.5	0.990	6213N
4.9	3.25	0.6	149.7	2.77	76	129	152	7.37	2	0.5	2.08	6313N
2.87	2.85	0.6	116.6	2.41	76.5	103.5	118	5.03	1	0.5	0.602	6014N
4.06	3.25	0.6	134.7	2.77	78	117	136.5	6.58	1.5	0.5	1.07	6214N
4.9	3.25	0.6	159.7	2.77	81	139	162	7.37	2	0.5	2.52	6314N
2.87	2.85	0.6	121.6	2.41	81.5	108.5	123	5.03	1	0.5	0.638	6015N
4.06	3.25	0.6	139.7	2.77	83	122	141.5	6.58	1.5	0.5	1.18	6215N
4.9	3.25	0.6	169.7	2.77	86	149	172	7.37	2	0.5	3.02	6315N

Single-row deep groove ball bearings

snap ring groove type

locating snap ring type

d 80 ~ 130 mm

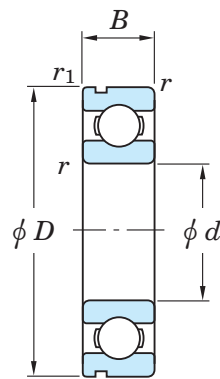

N
With snap ring groove

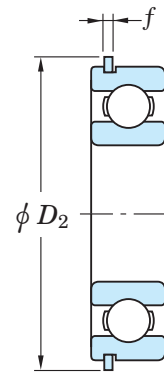

NR
With locating snap ring

Boundary dimensions (mm)					Basic load ratings (kN)		Factor	Limiting speeds (min ⁻¹)		Bearing No.		D_1 max.
d	D	B	r min.	r_1 min.	C_r	C_{Or}	f_0	Grease lub.	Oil lub.	With snap ring groove	With locating snap ring	
80	125	22	1.1	0.5	47.6	39.8	15.6	5 300	6 300	6016N	6016NR	120.22
	140	26	2	0.5	72.7	53.0	14.6	4 500	5 400	6216N	6216NR	135.23
	170	39	2.1	0.5	123	86.7	13.3	3 900	4 700	6316N	6316NR	163.65
85	130	22	1.1	0.5	49.5	43.1	15.8	5 000	5 900	6017N	6017NR	125.22
	150	28	2	0.5	84.0	61.9	14.5	4 200	5 000	6217N	6217NR	145.24
	180	41	3	0.5	133	96.8	13.3	3 700	4 400	6317N	6317NR	173.66
90	140	24	1.5	0.5	58.2	49.7	15.6	4 700	5 600	6018N	6018NR	135.23
	160	30	2	0.5	96.1	71.5	14.5	3 900	4 700	6218N	6218NR	155.22
	190	43	3	0.5	143	107	13.3	3 500	4 200	6318N	6318NR	183.64
95	145	24	1.5	0.5	60.4	53.9	15.8	4 400	5 200	6019N	6019NR	140.23
	170	32	2.1	0.5	109	81.9	14.4	3 700	4 400	6219N	6219NR	163.65
	200	45	3	0.5	153	119	13.3	3 300	4 000	6319N	6319NR	193.65
100	150	24	1.5	0.5	60.2	54.2	15.9	4 300	5 100	6020N	6020NR	145.24
	180	34	2.1	0.5	122	93.1	14.4	3 500	4 200	6220N	6220NR	173.66
105	160	26	2	0.5	72.3	65.8	15.8	4 000	4 700	6021N	6021NR	155.22
	190	36	2.1	0.5	133	105	14.4	3 300	3 900	6221N	6221NR	183.64
110	170	28	2	0.5	82.0	73.0	15.6	3 800	4 500	6022N	6022NR	163.65
	200	38	2.1	0.5	144	117	14.4	3 100	3 700	6222N	6222NR	193.65
120	180	28	2	0.5	85.0	79.3	15.9	3 600	4 200	6024N	6024NR	173.66
130	200	33	2	0.5	106	101	15.8	3 200	3 800	6026N	6026NR	193.65

[Remark] Standard cage types used for the above bearings are described earlier in this section.

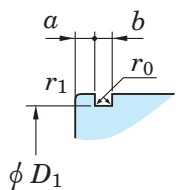

Snap ring groove details

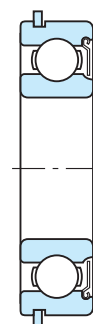
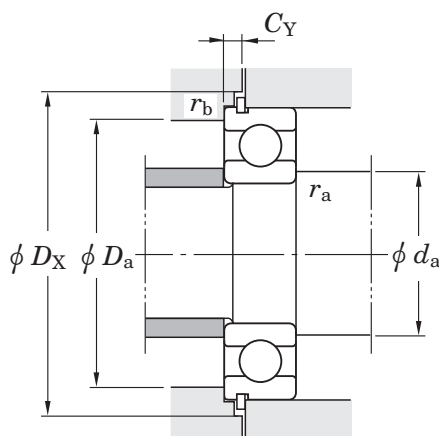

With locating snap ring and one shield

Dimensions of snap ring groove (mm)			Dimensions of locating snap ring (mm)		Mounting dimensions (mm)						(Refer.) Mass (kg)	(Refer.) Bearing No.
<i>a</i>	<i>b</i>	<i>r</i> ₀	<i>D</i> ₂	<i>f</i>	<i>d</i> _a	<i>D</i> _a	<i>D</i> _X	<i>C</i> _Y	<i>r</i> _a	<i>r</i> _b		
max.	±0.15	max.	max.	±0.05	min.	max.	min.	max.	max.	max.		
2.87	3.25	0.6	134.7	2.77	86.5	118.5	136.5	5.39	1	0.5	0.850	6016N
4.9	3.25	0.6	149.7	2.77	89	131	152	7.37	2	0.5	1.40	6216N
5.69	3.65	0.6	182.9	3.05	91	159	185	8.44	2	0.5	3.59	6316N
2.87	3.25	0.6	139.7	2.77	91.5	123.5	141.5	5.39	1	0.5	0.890	6017N
4.9	3.25	0.6	159.7	2.77	94	141	162	7.37	2	0.5	1.79	6217N
5.69	3.65	0.6	192.9	3.05	98	167	195	8.44	2.5	0.5	4.23	6317N
3.71	3.25	0.6	149.7	2.77	98	132	152	6.17	1.5	0.5	1.16	6018N
4.9	3.25	0.6	169.7	2.77	99	151	172	7.37	2	0.5	2.15	6218N
5.69	3.65	0.6	202.9	3.05	103	177	205	8.44	2.5	0.5	4.91	6318N
3.71	3.25	0.6	154.7	2.77	103	137	157	6.17	1.5	0.5	1.21	6019N
5.69	3.65	0.6	182.9	3.05	106	159	185	8.44	2	0.5	2.62	6219N
5.69	3.65	0.6	212.9	3.05	108	187	215	8.44	2.5	0.5	5.67	6319N
3.71	3.25	0.6	159.7	2.77	108	142	162	6.17	1.5	0.5	1.25	6020N
5.69	3.65	0.6	192.9	3.05	111	169	195	8.44	2	0.5	3.14	6220N
3.71	3.25	0.6	169.7	2.77	114	151	172	6.17	2	0.5	1.59	6021N
5.69	3.65	0.6	202.9	3.05	116	179	205	8.44	2	0.5	3.70	6221N
3.71	3.65	0.6	182.9	3.05	119	161	185	6.45	2	0.5	1.96	6022N
5.69	3.65	0.6	212.9	3.05	121	189	215	8.44	2	0.5	4.36	6222N
3.71	3.65	0.6	192.9	3.05	129	171	195	6.45	2	0.5	2.07	6024N
5.69	3.65	0.6	212.9	3.05	139	191	215	8.44	2	0.5	3.16	6026N

Extra-small ball bearings, miniature ball bearings

d 1 ~ (4) mm

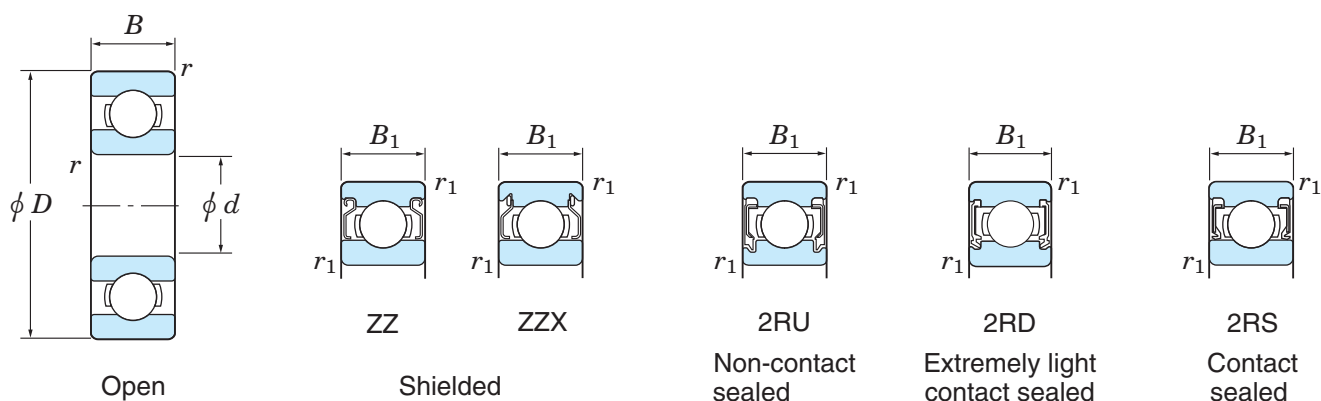

d	Boundary dimensions (mm)					Basic load ratings (kN)		Factor f_0	Limiting speeds (min^{-1})			
	D	B	B_1	$r_1^{1)}$ min.	$r_1^{1)}$ min.	C_r	C_{0r}		Grease lub.		Oil lub.	
									[Open ZZ, 2RU]	(2RD)	(2RS)	[Open Z]
1	3	1	—	0.07	—	0.10	0.03	11.6	130 000	—	—	150 000
	3	1.5	—	0.08	—	0.08	0.02	12.8	130 000	—	—	150 000
	4	1.6	—	0.1	—	0.14	0.04	11.4	120 000	—	—	140 000
1.2	4	1.8	—	0.08	—	0.11	0.03	11.4	120 000	—	—	140 000
1.5	4	1.2	2	0.1	0.1	0.11	0.03	13.2	120 000	—	—	140 000
	5	2	2.6	0.15	0.15	0.24	0.07	13.3	110 000	—	—	130 000
	6	2.5	3	0.1	0.1	0.33	0.10	11.4	86 000	—	—	100 000
2	5	1.5	2.3	0.1	0.1	0.17	0.05	13.3	98 000	—	—	110 000
	5	2	2.5	0.1	0.08	0.17	0.05	13.3	98 000	—	—	110 000
	6	2.3	3	0.15	0.1	0.33	0.10	11.4	86 000	—	—	100 000
	6	2.5	3	0.1	0.1	0.33	0.10	11.4	86 000	—	—	100 000
	7	2.5	3	0.15	0.15	0.39	0.13	12.6	67 000	—	—	79 000
	7	2.8	3.5	0.15	0.15	0.39	0.13	12.6	67 000	—	—	79 000
2.5	6	1.8	2.6	0.1	0.1	0.19	0.06	14.3	75 000	—	—	89 000
	7	2.5	3.5	0.15	0.15	0.31	0.11	13.7	66 000	—	—	79 000
	8	2.5	—	0.1	—	0.43	0.15	13.4	63 000	—	—	75 000
	8	2.8	4	0.15	0.1	0.55	0.17	11.5	64 000	—	—	76 000
3	6	2	2.5	0.08	0.05	0.19	0.06	14.3	75 000	—	—	89 000
	7	2	3	(0.15)	(0.15)	0.31	0.11	13.7	66 000	—	—	79 000
	8	2.5	—	0.1	—	0.40	0.14	13.4	63 000	—	—	75 000
	8	3	4	0.15	0.15	0.55	0.17	11.5	64 000	—	—	76 000
	9	3	5	0.15	0.15	0.43	0.16	14.0	60 000	—	—	72 000
	10	4	4	0.15	0.15	0.63	0.22	12.8	52 000	—	44 000	63 000
	13	5	5	0.2	0.2	1.30	0.49	12.3	44 000	—	—	54 000
4	7	2	2.5	0.08	0.05	0.26	0.11	15.1	64 000	—	—	76 000
	8	2	3	0.1	0.08	0.40	0.14	14.6	61 000	—	—	73 000
	9	2.5	4	(0.15)	(0.15)	0.64	0.23	12.8	59 000	—	—	70 000

[Note] 1) Numerical values in () do not conform to JIS B 1521.

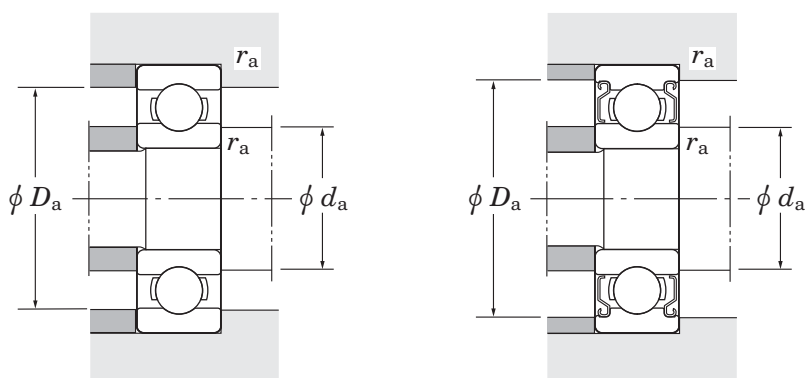

	Bearing No.					Mounting dimensions (mm)			(Refer.) Mass (g)
	Open	Shielded	Non-contact sealed	Extremely light shielded	Contact sealed	d_a min.	D_a max.	r_a max.	
	681	—	—	—	—	1.6	2.4	0.05	0.03
	ML1003	—	—	—	—	1.6	2.4	0.07	0.05
	691	—	—	—	—	1.8	3.2	0.1	0.1
	ML1204	—	—	—	—	1.8	3.4	0.07	0.1
	68/1.5	W68/1.5 ZZ	—	—	—	2.3	3.2	0.1	0.1
	69/1.5	W69/1.5 ZZX	—	—	—	2.7	3.8	0.15	0.1
	ML1506	WML1506 ZZX	—	—	—	2.3	5.2	0.1	0.3
	682	W682 ZZX	—	—	—	2.8	4.4	0.1	0.1
	ML2005	WML2005 ZZ	—	—	—	2.6	4.2	0.07	0.1
	692	W692 ZZ	—	—	—	3.2	4.8	0.1	0.2
	ML2006	WML2006 ZZX	—	—	—	2.8	5.2	0.1	0.3
	ML2007	WML2007 ZZX	—	—	—	3.2	5.8	0.15	0.4
	602	W602 ZZX	—	—	—	3.2	5.8	0.15	0.5
	68/2.5	W68/2.5 ZZ	—	—	—	3.3	5.2	0.1	0.2
	69/2.5	W69/2.5 ZZ	—	—	—	3.7	5.8	0.15	0.4
	ML2508/1B	—	—	—	—	3.3	7.2	0.1	0.6
	ML2508	WML2508 ZZX	—	—	—	3.7	6.8	0.1	0.6
	ML3006	WML3006 ZZ	—	—	—	3.6	5.4	0.05	0.2
	683	W683 ZZ	—	—	—	4.2	5.8	0.1	0.3
	ML3008	—	—	—	—	3.8	7.2	0.1	0.5
	693	W693 ZZ	—	—	—	4.2	6.8	0.15	0.6
	603	W603 ZZX	—	—	—	4.2	7.8	0.15	0.9
	623	623 ZZ	—	—	623 2RS	4.2	8.8	0.15	1.6
	633	633 ZZ	—	—	—	4.6	11.4	0.2	3.0
	ML4007	WML4007 ZZ	—	—	—	4.6	6.4	0.05	0.2
	ML4008	WML4008 ZZ	—	—	—	4.8	7.2	0.08	0.4
	684	W684 ZZ	—	—	—	5.2	7.8	0.1	0.6

Extra-small ball bearings, miniature ball bearings

d (4) ~ (7) mm

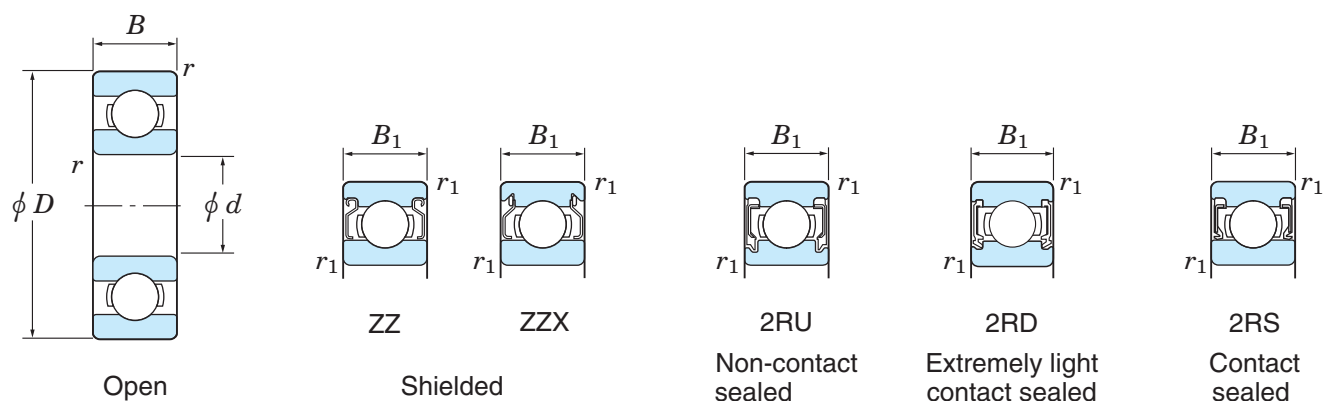

d	Boundary dimensions (mm)					Basic load ratings (kN)		Factor f_0	Limiting speeds (min^{-1})			
	D	B	B_1	$r_{\text{min.}}$	$r_1_{\text{min.}}$	C_r	C_{0r}		Grease lub.		Oil lub.	
									[Open ZZ, 2RU]	(2RD)	(2RS)	[Open Z]
4	10	3	4	0.15	0.1	0.65	0.23	13.3	56 000	—	—	67 000
	11	4	4	0.15	0.15	0.96	0.35	12.4	54 000	—	44 000	65 000
	12	4	4	0.2	0.2	0.96	0.35	12.4	53 000	—	—	63 000
	13	5	5	0.2	0.2	1.30	0.48	12.3	44 000	—	39 000	54 000
	16	5	5	0.3	0.3	1.35	0.52	12.4	40 000	—	—	49 000
5	8	2	2.5	0.08	0.05	0.22	0.09	15.7	59 000	—	—	70 000
	9	2.5	3	0.1	0.08	0.43	0.17	15.3	56 000	—	—	67 000
	10	3	4	0.1	0.1	0.43	0.17	14.8	55 000	—	—	65 000
	11	3	5	0.15	0.15	0.71	0.28	12.8	53 000	—	—	63 000
	13	4	4	0.2	0.2	1.10	0.43	12.3	50 000	45 000	42 000	60 000
	14	5	5	0.2	0.2	1.30	0.49	12.3	50 000	—	—	60 000
	16	5	5	0.3	0.3	1.75	0.67	12.4	40 000	36 000	33 000	49 000
	19	6	6	0.3	0.3	2.35	0.89	12.3	35 000	32 000	27 000	43 000
6	10	2.5	3	0.1	0.08	0.50	0.22	15.7	53 000	—	—	63 000
	12	3	4	0.15	0.1	0.71	0.29	14.5	49 000	—	37 000	59 000
	13	3.5	5	0.15	0.15	1.10	0.44	13.7	48 000	43 000	36 000	57 000
	15	5	5	0.2	0.2	1.35	0.52	12.4	45 000	41 000	32 000	54 000
	17	6	6	0.3	0.3	1.95	0.74	12.2	43 000	39 000	—	51 000
	19	6	6	0.3	0.3	2.35	0.89	12.3	35 000	32 000	27 000	43 000
	19	8	8	0.3	0.3	2.60	1.05	12.3	40 000	—	—	47 000
	22	7	7	0.3	0.3	3.30	1.35	12.4	31 000	—	23 000	37 000
7	11	2.5	3	0.1	0.08	0.43	0.23	16.1	49 000	—	—	59 000
	13	3	4	0.15	0.15	0.54	0.28	14.9	47 000	—	—	55 000
	14	3.5	5	0.15	0.15	1.15	0.51	14.2	45 000	—	—	54 000
	17	5	5	0.3	0.3	1.60	0.71	14.0	42 000	—	28 000	50 000
	19	6	6	0.3	0.3	2.35	0.89	12.3	40 000	36 000	27 000	47 000
	22	7	7	0.3	0.3	3.30	1.35	12.4	31 000	28 000	23 000	37 000
	22	8	8	0.3	0.3	3.30	1.35	12.4	34 000	—	—	41 000

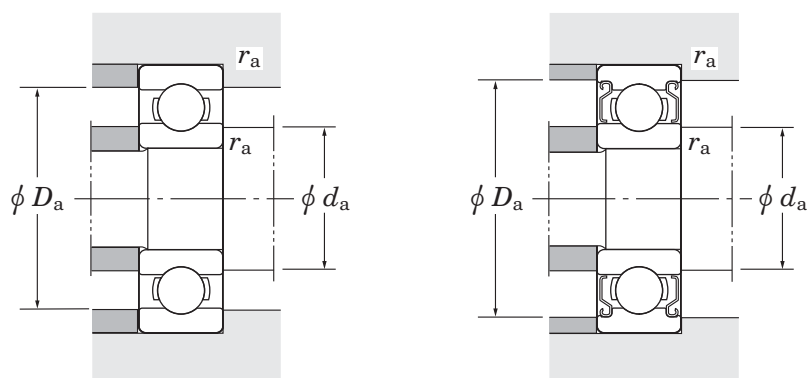

	Bearing No.					Mounting dimensions (mm)			(Refer.) Mass (g)
	Open	Shielded	Non-contact sealed	Extremely light shielded	Contact sealed	d_a min.	D_a max.	r_a max.	
ML4010		WML4010 ZZ	—	—	—	5.2	8.8	0.1	1.0
694		694 ZZ	694 2RU	—	694 2RS	5.2	9.8	0.15	1.8
604		604 ZZ	—	—	—	5.6	10.4	0.2	2.1
624		624 ZZ	624 2RU	—	624 2RS	5.6	11.4	0.2	2.9
634		634 ZZ	—	—	—	6	14	0.3	5.3
ML5008		WML5008 ZZ	—	—	—	5.6	7.4	0.05	0.3
ML5009		WML5009 ZZ	—	—	—	5.8	8.2	0.08	0.5
ML5010		WML5010 ZZ	—	—	—	5.8	9	0.1	0.9
685		W685 ZZ	—	—	—	6.2	9.8	0.15	1.0
695		695 ZZ	695 2RU	695 2RD	695 2RS	6.6	11.4	0.2	2.2
605		605 ZZ	—	—	—	6.6	12.4	0.2	3.5
625		625 ZZ	625 2RU	—	625 2RS	7	14	0.3	5.0
635		635 ZZ	635 2RU	—	635 2RS	7	17	0.3	8.5
ML6010		WML6010 ZZ	—	—	—	6.8	9.2	0.08	0.6
ML6012		WML6012 ZZ	—	—	WML6012 2RS	7.2	10.8	0.1	1.3
686		W686 ZZ	—	—	W686 2RS	7.2	11.8	0.15	1.8
696		696 ZZ	696 2RU	696 2RD	696 2RS	7.6	13.4	0.2	3.9
606		606 ZZ	606 2RU	606 2RD	—	8	15	0.3	5.8
626		626 ZZ	626 2RU	626 2RD	626 2RS	8	17	0.3	8.1
ML6019		ML6019 ZZ	—	—	—	7	18	0.3	9.0
636		636 ZZ	—	—	636 2RS	8	20	0.3	13
ML7011		WML7011 ZZX	—	—	—	7.8	10.2	0.08	0.7
ML7013		WML7013 ZZ	—	—	—	8.2	11.8	0.15	1.4
687		W687 ZZ	—	—	—	8.2	12.8	0.15	2.0
697		697 ZZ	—	—	697 2RS	9	15	0.3	5.3
607		607 ZZ	607 2RU	607 2RD	607 2RS	9	17	0.3	7.6
627		627 ZZ	627 2RU	627 2RD	627 2RS	9	20	0.3	13
ML7022		ML7022 ZZ	—	—	—	9	20	0.3	14

Extra-small ball bearings, miniature ball bearings

d (7) ~ 9 mm

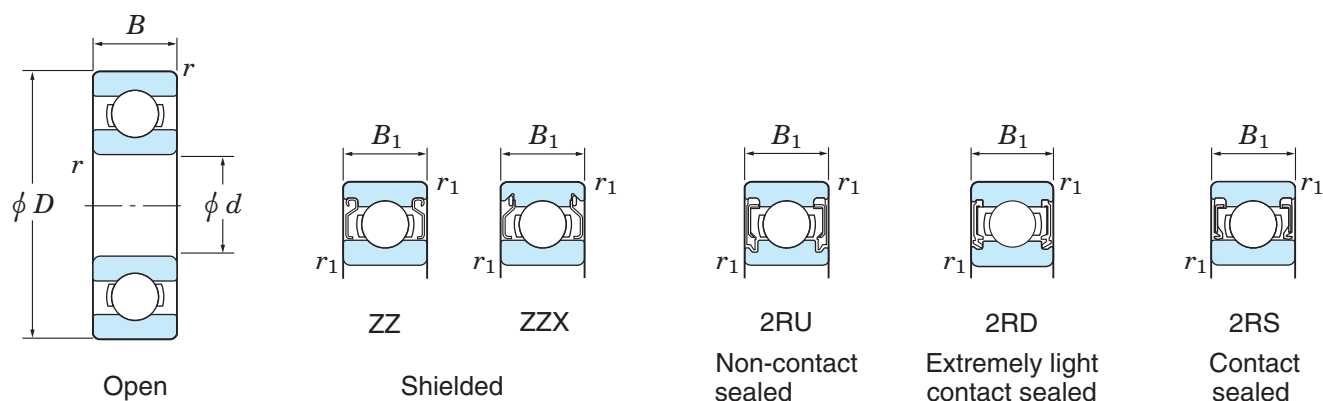

d	Boundary dimensions (mm)					Basic load ratings (kN)		Factor f_0	Limiting speeds (min^{-1})			
	D	B	B_1	$r_{\text{min.}}^{1)}$	$r_1^{1)}$	C_r	C_{0r}		Grease lub.		Oil lub.	
									[Open ZZ, 2RU]	(2RD)	(2RS)	[Open Z]
7	26	9	9	0.3	0.3	4.55	1.95	12.3	26 000	—	—	32 000
8	12	2.5	3.5	0.1	0.08	0.54	0.27	16.4	47 000	—	—	55 000
	14	3.5	4	0.15	0.15	0.81	0.39	15.3	44 000	—	—	52 000
	16	4	5	0.2	0.2	1.25	0.59	14.0	42 000	38 000	28 000	50 000
	19	6	6	0.3	0.3	2.25	0.91	12.9	39 000	35 000	27 000	46 000
	22	7	7	0.3	0.3	3.30	1.35	12.4	34 000	31 000	23 000	41 000
	24	8	8	0.3	0.3	3.35	1.40	12.8	28 000	—	22 000	35 000
	28	9	9	0.3	0.3	4.55	1.95	12.3	26 000	23 000	—	32 000
9	17	4	5	0.2	0.2	1.35	0.66	14.9	39 000	35 000	—	46 000
	20	6	6	0.3	0.3	2.45	1.05	13.3	35 000	32 000	25 000	42 000
	24	7	7	0.3	0.3	3.35	1.40	12.8	33 000	30 000	22 000	40 000
	26	8	8	(0.6)	(0.6)	4.55	1.95	12.4	27 000	24 000	19 000	33 000
	30	10	10	0.6	0.6	4.65	2.10	12.3	24 000	—	—	29 000

[Note] 1) Numerical values in () do not conform to JIS B 1521.

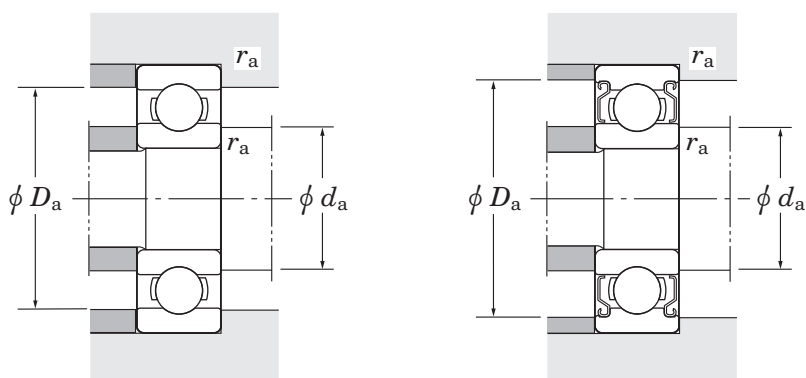

	Bearing No.					Mounting dimensions (mm)			(Refer.) Mass (g)
	Open	Shielded	Non-contact sealed	Extremely light shielded	Contact sealed	d_a min.	D_a max.	r_a max.	
	637	637 ZZ	—	—	—	9	24	0.3	24
	ML8012	WML8012 ZZ	—	—	—	8.8	11.2	0.08	0.8
	ML8014	WML8014 ZZ	—	—	—	9.2	12.8	0.15	1.8
	688	W688 ZZ	W688 2RU	W688 2RD	W688 2RS	9.6	14.4	0.2	3.2
	698	698 ZZ	—	698 2RD	698 2RS	10	17	0.3	7.2
	608	608 ZZ	608 2RU	608 2RD	608 2RS	10	20	0.3	12
	628	628 ZZ	628 2RU	—	628 2RS	10	22	0.3	18
	638	638 ZZ	—	638 2RD	—	10	26	0.3	29
	689	W689 ZZ	W689 2RU	W689 2RD	—	10.6	15.4	0.2	3.5
	699	699 ZZ	—	699 2RD	699 2RS	11	18	0.3	7.5
	609	609 ZZ	609 2RU	609 2RD	609 2RS	11	22	0.3	15
	629	629 ZZ	629 2RU	629 2RD	629 2RS	12.1	22	0.3	20
	639	639 ZZ	—	—	—	13	26	0.6	35

Extra-small ball bearings, miniature ball bearings flanged type

d 1 ~ (4) mm

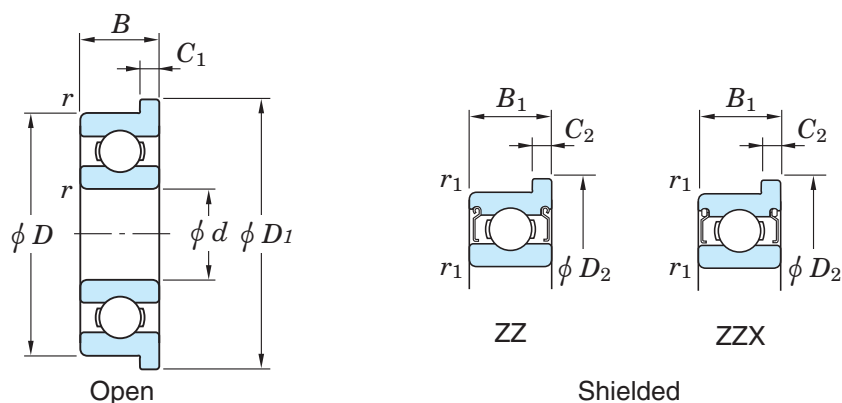

Boundary dimensions (mm)						Basic load ratings (kN)		Factor	Limiting speeds (min ⁻¹)		Bearing No.
d	D	B	B_1	$r^{1)}$ min.	$r_1^{1)}$ min.	C_r	C_{0r}	f_0	Grease lub. { Open ZZ, ZZX }	Oil lub. { Open Z, ZX }	Open
1	3	1	—	0.07	—	0.10	0.03	11.6	130 000	150 000	F681
	4	1.6	—	0.1	—	0.14	0.04	11.4	120 000	140 000	F691
1.5	4	1.2	2	0.1	0.1	0.11	0.03	13.2	120 000	140 000	F68/1.5
	5	2	2.6	0.15	0.15	0.24	0.07	12.9	110 000	120 000	F69/1.5
	6	2.5	3	0.1	0.1	0.33	0.10	11.4	86 000	100 000	MLF1506
2	5	1.5	2.3	0.1	0.1	0.17	0.05	13.3	99 000	120 000	F682
	5	2	2.5	0.1	0.08	0.17	0.05	12.9	99 000	120 000	MLF2005
	6	2.3	3	0.15	0.1	0.33	0.10	11.4	86 000	100 000	F692
	6	2.5	3	0.1	0.1	0.33	0.10	11.4	86 000	100 000	MLF2006
	7	2.5	3	0.15	0.15	0.39	0.13	12.6	67 000	79 000	MLF2007
	7	2.8	3.5	0.15	0.15	0.39	0.13	12.6	67 000	79 000	F602
2.5	6	1.8	2.6	0.1	0.1	0.21	0.07	14.3	69 000	82 000	F68/2.5
	7	2.5	3.5	0.15	0.15	0.39	0.13	12.7	66 000	79 000	F69/2.5
	8	2.5	—	0.1	—	0.56	0.18	11.7	63 000	75 000	MLF2508/1B
	8	2.8	4	0.15	0.1	0.56	0.18	11.5	63 000	75 000	MLF2508
3	6	2	2.5	0.08	0.05	0.21	0.07	14.3	69 000	82 000	MLF3006
	7	2	3	(0.15)	(0.15)	0.31	0.11	14.0	65 000	78 000	F683
	8	2.5	—	0.1	—	0.40	0.14	13.4	61 000	72 000	MLF3008
	8	3	4	0.15	0.15	0.56	0.18	11.9	63 000	75 000	F693
	9	3	5	0.15	0.15	0.57	0.19	12.4	60 000	72 000	F603
	10	4	4	0.15	0.15	0.63	0.22	12.4	61 000	72 000	F623
4	7	2	2.5	0.08	0.05	0.25	0.11	15.1	63 000	75 000	MLF4007
	8	2	3	0.1	0.08	0.40	0.14	13.9	61 000	72 000	MLF4008
	9	2.5	4	(0.15)	(0.15)	0.64	0.23	12.8	59 000	70 000	F684
	10	3	4	0.15	0.1	0.71	0.27	13.5	56 000	66 000	MLF4010
	11	4	4	0.15	0.15	0.96	0.35	12.4	54 000	65 000	F694
	12	4	4	0.2	0.2	0.96	0.35	12.4	54 000	65 000	F604

[Note] 1) Numerical values in () do not conform to JIS B 1521.

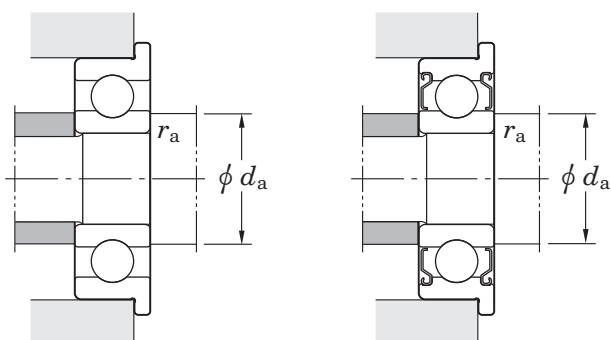

Shielded	Dimensions of flange (mm)				Mounting dimensions (mm)		(Refer.) Mass (g)
	D_1	D_2	C_1	C_2	d_a min.	r_a max.	
—	3.8	—	0.3	—	1.6	0.05	0.03
—	5	—	0.5	—	1.8	0.1	0.1
WF68/1.5 ZZ	5	5	0.4	0.6	2.3	0.1	0.1
WF69/1.5 ZZ	6.5	6.5	0.6	0.8	2.7	0.15	0.2
WMLF1506 ZZ	7.5	7.5	0.6	0.8	2.3	0.1	0.4
WF682 ZZ	6.1	6.1	0.5	0.6	2.8	0.1	0.1
WMLF2005 ZZ	6.2	6.2	0.6	0.6	2.8	0.07	0.2
WF692 ZZ	7.5	7.5	0.6	0.8	3.2	0.1	0.3
WMLF2006 ZZ	7.2	7.2	0.6	0.6	2.8	0.1	0.4
WMLF2007 ZZ	8.2	8.2	0.6	0.6	3.2	0.15	0.5
WF602 ZZ	8.5	8.5	0.7	0.9	3.2	0.15	0.6
WF68/2.5 ZZ	7.1	7.1	0.5	0.8	3.3	0.1	0.2
WF69/2.5 ZZ	8.5	8.5	0.7	0.9	3.7	0.15	0.5
—	9.2	—	0.6	—	3.5	0.1	0.7
WMLF2508 ZZ	9.5	9.5	0.7	0.9	3.7	0.1	0.7
WMLF3006 ZZ	7.2	7.2	0.6	0.6	3.6	0.05	0.2
WF683 ZZ	8.1	8.1	0.5	0.8	4.2	0.1	0.4
—	9.2	—	0.6	—	4.0	0.1	0.6
WF693 ZZ	9.5	9.5	0.7	0.9	4.2	0.15	0.7
WF603 ZZ	10.5	10.5	0.7	1	4.2	0.15	1.0
F623 ZZ	11.5	11.5	1	1	4.2	0.15	1.8
WMLF4007 ZZ	8.2	8.2	0.6	0.6	4.6	0.05	0.3
WMLF4008 ZZ	9.2	9.2	0.6	0.6	4.8	0.08	0.5
WF684 ZZ	10.3	10.3	0.6	1	5.2	0.1	0.7
WMLF4010 ZZ	11.2	11.6	0.6	0.8	5.2	0.1	1.1
F694 ZZ	12.5	12.5	1	1	5.2	0.15	2.0
F604 ZZ	13.5	13.5	1	1	5.6	0.2	2.3

Extra-small ball bearings, miniature ball bearings flanged type

d (4) ~ 8 mm

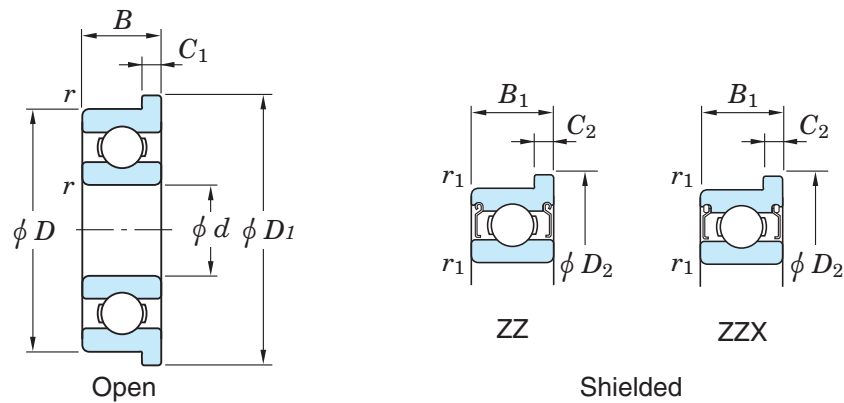

d	Boundary dimensions (mm)					Basic load ratings (kN)		Factor f_0	Limiting speeds (min^{-1})		Bearing No. Open
	D	B	B_1	$r_{\text{min.}}$	$r_{1\text{min.}}$	C_r	C_{0r}		Grease lub. { Open ZZ, ZZX }	Oil lub. { Open Z, ZX }	
4	13	5	5	0.2	0.2	1.30	0.48	12.2	50 000	60 000	F624 F634
	16	5	5	0.3	0.3	1.35	0.52	13.0	47 000	55 000	
5	8	2	2.5	0.08	0.05	0.22	0.09	15.8	59 000	70 000	MLF5008 MLF5009 MLF5010 F685 F695 F605 F625 F635
	9	2.5	3	0.1	0.08	0.43	0.17	14.6	57 000	67 000	
	10	3	4	0.1	0.1	0.43	0.17	14.8	57 000	67 000	
	11	3	5	0.15	0.15	0.71	0.28	14.0	53 000	63 000	
	13	4	4	0.2	0.2	1.10	0.43	13.4	49 000	59 000	
	14	5	5	0.2	0.2	1.35	0.51	12.3	48 000	57 000	
	16	5	5	0.3	0.3	1.75	0.67	12.4	45 000	54 000	
19	6	6	0.3	0.3	2.35	0.89	12.3	40 000	47 000		
6	10	2.5	3	0.1	0.08	0.50	0.22	15.2	53 000	63 000	MLF6010 MLF6012 F686 F696 F606 F626 F636
	12	3	4	0.15	0.1	0.71	0.29	14.5	49 000	59 000	
	13	3.5	5	0.15	0.15	1.10	0.44	13.7	48 000	57 000	
	15	5	5	0.2	0.2	1.35	0.52	13.0	47 000	55 000	
	17	6	6	0.3	0.3	2.25	0.84	11.4	43 000	52 000	
	19	6	6	0.3	0.3	2.35	0.89	12.3	40 000	47 000	
	22	7	7	0.3	0.3	3.30	1.35	12.4	34 000	41 000	
7	11	2.5	3	0.1	0.08	0.46	0.20	15.6	49 000	59 000	MLF7011 MLF7013 F687 F697 F607 F627
	13	3	4	0.15	0.15	0.54	0.28	16.0	46 000	55 000	
	14	3.5	5	0.15	0.15	1.15	0.51	14.2	45 000	54 000	
	17	5	5	0.3	0.3	1.60	0.71	14.0	42 000	50 000	
	19	6	6	0.3	0.3	2.35	0.89	12.1	40 000	47 000	
	22	7	7	0.3	0.3	3.30	1.35	12.4	34 000	41 000	
8	12	2.5	3.5	0.1	0.08	0.54	0.27	15.9	47 000	55 000	MLF8012 MLF8014 F688 F698 F608
	14	3.5	4	0.15	0.15	0.87	0.42	15.3	44 000	52 000	
	16	4	5	0.2	0.2	1.25	0.59	14.8	42 000	50 000	
	19	6	6	0.3	0.3	2.25	0.91	12.9	39 000	46 000	
	22	7	7	0.3	0.3	3.30	1.35	12.4	34 000	41 000	

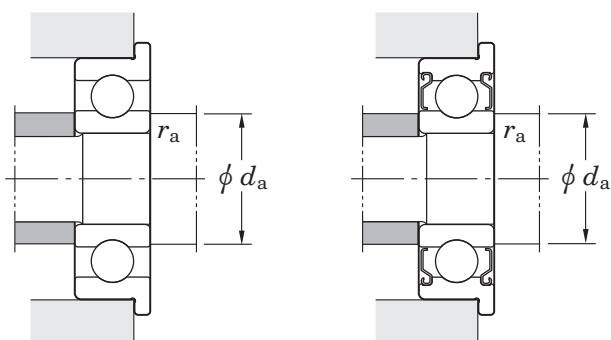

Shielded	Dimensions of flange (mm)				Mounting dimensions (mm)		(Refer.) Mass (g)
	D_1	D_2	C_1	C_2	d_a min.	r_a max.	
F624 ZZ	15	15	1	1	5.6	0.2	3.3
F634 ZZ	18	18	1	1	6	0.3	5.7
WMLF5008 ZZX	9.2	9.2	0.6	0.6	5.6	0.05	0.4
WMLF5009 ZZX	10.2	10.2	0.6	0.6	5.8	0.08	0.6
WMLF5010 ZZ	11.2	11.6	0.6	0.8	5.8	0.1	1.0
WF685 ZZ	12.5	12.5	0.8	1	6.2	0.15	1.1
F695 ZZ	15	15	1	1	6.6	0.2	2.5
F605 ZZ	16	16	1	1	6.6	0.2	3.9
F625 ZZ	18	18	1	1	7	0.3	5.4
F635 ZZ	22	22	1.5	1.5	7	0.3	9.7
WMLF6010 ZZX	11.2	11.2	0.6	0.6	6.8	0.08	0.7
WMLF6012 ZZ	13.2	13.6	0.6	0.8	7.2	0.1	1.4
WF686 ZZ	15	15	1	1.1	7.2	0.15	2.1
F696 ZZ	17	17	1.2	1.2	7.6	0.2	4.3
F606 ZZ	19	19	1.2	1.2	8	0.3	6.3
F626 ZZ	22	22	1.5	1.5	8	0.3	9.2
F636 ZZ	25	25	1.5	1.5	8	0.3	14
WMLF7011 ZZX	12.2	12.2	0.6	0.6	7.8	0.08	0.8
WMLF7013 ZZ	14.2	14.6	0.6	0.8	8.2	0.15	1.5
WF687 ZZ	16	16	1	1.1	8.2	0.15	2.4
F697 ZZ	19	19	1.2	1.2	9	0.3	5.8
F607 ZZ	22	22	1.5	1.5	9	0.3	8.7
F627 ZZ	25	25	1.5	1.5	9	0.3	14
WMLF8012 ZZX	13.2	13.6	0.6	0.8	8.8	0.08	0.9
WMLF8014 ZZ	15.6	15.6	0.8	0.8	9.2	0.15	2.0
WF688 ZZ	18	18	1	1.1	9.6	0.2	3.6
F698 ZZ	22	22	1.5	1.5	10	0.3	8.3
F608 ZZ	25	25	1.5	1.5	10	0.3	13

Extra-small ball bearings, miniature ball bearings flanged type

d 9 mm

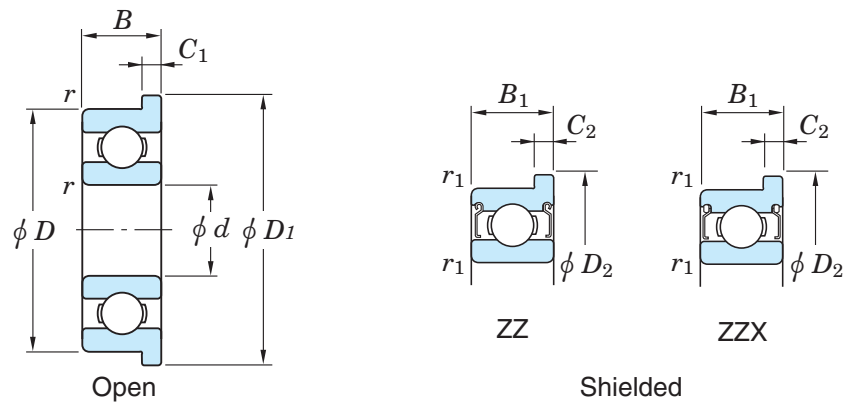

d	Boundary dimensions (mm)					Basic load ratings (kN)		Factor f_0	Limiting speeds (min^{-1})		Bearing No.
	D	B	B_1	$r_{\text{min.}}$	$r_1_{\text{min.}}$	C_r	C_{0r}		Grease lub.	Oil lub.	
9	17	4	5	0.2	0.2	1.35	0.66	15.1	[Open ZZ, ZZX]	[Open Z, ZX]	Open
	20	6	6	0.3	0.3	2.45	1.05	13.3	39 000	46 000	F689
	24	7	7	0.3	0.3	3.35	1.45	12.8	37 000	44 000	F699
									32 000	38 000	F609

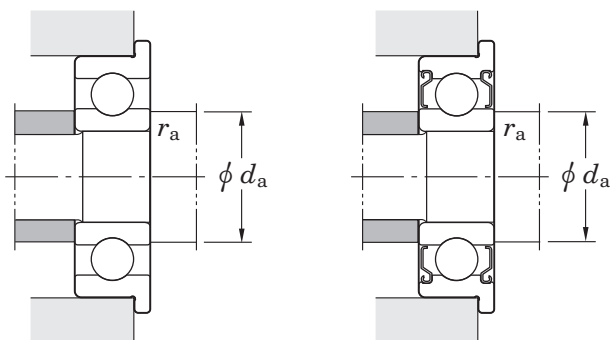

Shielded	Dimensions of flange (mm)				Mounting dimensions (mm)		(Refer.) Mass (g)
	D_1	D_2	C_1	C_2	d_a min.	r_a max.	
WF689 ZZ	19	19	1	1.1	10.6	0.2	3.9
F699 ZZ	23	23	1.5	1.5	11	0.3	8.7
F609 ZZ	27	27	1.5	1.5	11	0.3	16

Double-row deep groove ball bearings

d 10 ~ (60) mm

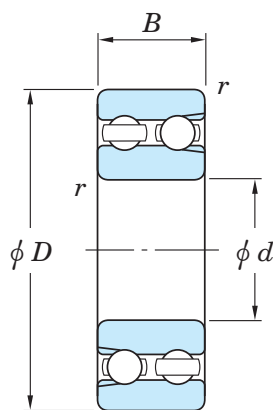

Boundary dimensions (mm)				Basic load ratings (kN)		Factor	Limiting speeds (min^{-1})		Bearing No.	Mounting dimensions (mm)			(Refer.) Mass (kg)
d	D	B	$r_{\text{min.}}$	C_R	C_{0R}	f_0	Grease lub.	Oil lub.		d_a min.	D_a max.	r_a max.	
10	30	14	0.6	7.70	5.90	13.0	15 000	20 000	4200	14	26	0.6	0.057
12	32	14	0.6	7.75	6.15	13.6	14 000	18 000	4201	16	28	0.6	0.062
15	35	14	0.6	9.75	9.00	14.2	12 000	16 000	4202	19	31	0.6	0.071
	42	17	1	13.1	11.7	13.7	11 000	14 000	4302	20	37	1	0.123
17	40	16	0.6	11.7	10.4	14.1	11 000	14 000	4203	21	36	0.6	0.106
	47	19	1	16.5	15.0	13.7	9 400	13 000	4303	22	42	1	0.171
20	47	18	1	16.4	16.0	14.2	9 000	12 000	4204	25	42	1	0.165
	52	21	1.1	19.5	17.0	13.5	8 300	11 000	4304	26.5	45.5	1	0.227
25	52	18	1	16.3	16.9	15.0	7 500	9 900	4205	30	47	1	0.189
	62	24	1.1	26.3	25.7	14.1	6 700	9 000	4305	31.5	55.5	1	0.365
30	62	20	1	22.0	24.7	15.1	6 400	8 500	4206	35	57	1	0.298
	72	27	1.1	35.5	35.9	14.0	5 700	7 600	4306	36.5	65.5	1	0.542
35	72	23	1.1	26.4	30.7	15.2	5 600	7 400	4207	41.5	65.5	1	0.460
	80	31	1.5	40.6	41.8	14.1	5 200	7 000	4307	43	72	1.5	0.752
40	80	23	1.1	33.7	42.4	15.5	4 700	6 300	4208	46.5	73.5	1	0.558
	90	33	1.5	46.0	48.8	14.7	4 600	6 100	4308	48	82	1.5	1.01
45	85	23	1.1	31.9	43.9	15.8	4 600	6 100	4209	51.5	78.5	1	0.605
	100	36	1.5	57.6	62.4	14.3	4 100	5 500	4309	53	92	1.5	1.35
50	90	23	1.1	31.4	44.6	16.1	4 200	5 600	4210	56.5	83.5	1	0.651
	110	40	2	70.4	77.7	14.2	3 700	5 000	4310	59	101	2	1.80
55	100	25	1.5	37.2	54.1	16.1	3 800	5 000	4211	63	92	1.5	0.882
	120	43	2	84.2	94.4	14.2	3 400	4 600	4311	64	111	2	2.29
60	110	28	1.5	47.9	67.6	15.9	3 500	4 700	4212	68	102	1.5	1.20

d (60) ~ 75 mm

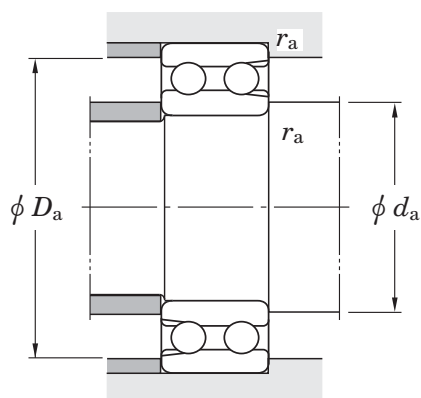

Boundary dimensions (mm)				Basic load ratings (kN)		Factor	Limiting speeds (min ⁻¹)		Bearing No.	Mounting dimensions (mm)			(Refer.) Mass (kg)
d	D	B	$r_{\min.}$	C_r	C_{Or}	f_0	Grease lub.	Oil lub.		d_a min.	D_a max.	r_a max.	
60	130	46	2.1	99.2	113	14.1	3 100	4 200	4312	71	119	2	2.87
65	120	31	1.5	54.7	78.5	15.9	3 200	4 300	4213	73	112	1.5	1.59
	140	48	2.1	107	124	14.3	2 900	3 900	4313	76	129	2	3.46
70	125	31	1.5	62.1	89.8	15.8	3 100	4 100	4214	78	117	1.5	1.68
	150	51	2.1	115	136	14.4	2 700	3 600	4314	81	139	2	4.21
75	130	31	1.5	61.6	90.7	16.0	2 900	3 900	4215	83	122	1.5	1.77
	160	55	2.1	132	158	14.4	2 500	3 400	4315	86	149	2	5.15

KOYO



Angular contact ball bearings

Angular contact ball bearings are suitable for applications which require high accuracy and good high-speed performance. This type of bearing is designed to carry a combined load.

■ Single-row angular contact ball bearings and matched pair angular contact ball bearings

- The standard contact angles are 15°, 30° and 40°. They are identified, respectively, by the supplementary codes "C", "A" (omitted) and "B". Bearings with a smaller contact angle are more suitable for applications involving high-speed rotation. Those with a larger contact angle feature superior axial load resistance.

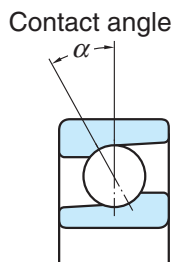

- Angular contact ball bearings are often preloaded to enhance their rigidity and rotating performance.

(refer to p. A 106.)

For high-precision matched pair angular contact ball bearings of class 5 or higher, which are used in machine tools and other precision equipment, the standard preload is specified in three levels: slight (S), light (L), medium (M) and heavy (H). (refer to Table 11-2 on p. A 108.)

- When this type of bearing is loaded radially, an axial component of force is produced. In this case, two bearings are used together facing one another, or two or more bearings are matched and used. (refer to p. A 34.)
- Tables 1 and 2 list the different types of single-row and matched pair/stack angular contact ball bearings and describe their characteristics.

■ Double-row angular contact ball bearings

Consist of two single-row angular contact ball bearings matched back-to-back, with inner and outer rings integrated.

Table 3 shows major types and their characteristics.

■ Four-point contact ball bearings

- Have a contact angle of 35° and an inner ring divided into two annular pieces. They are suitable for applications that involve either axial loading or combined loading, where the axial load makes up the major part of the load.
- Able to support both axial load and a certain degree of radial load. Each rolling element is in contact with each of the inner and outer rings at a single point, and both contact points lie on the contact angle line. The line runs to either the right or left depending on the direction of the axial load.

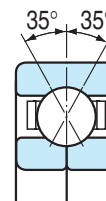

Single-row angular contact ball bearings

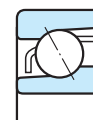

Bore diameter 10 – 380 mm

Matched pair angular contact ball bearings

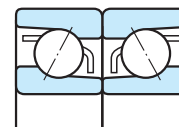

Bore diameter 10 – 380 mm

Double-row angular contact ball bearings

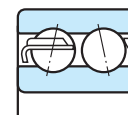

Bore diameter 10 – 110 mm

Four-point contact ball bearings

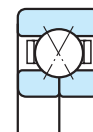

Bore diameter 20 – 110 mm

- Consult with JTEKT when using the four-point contact ball bearing because application conditions such as load magnitude should be examined carefully.

Table 1 Single-row angular contact ball bearings

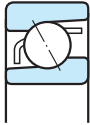
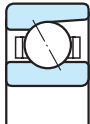
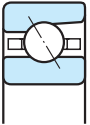
<p>Standard type</p>  <p>(with pressed cage)</p>  <p>(with machined cage)</p>	<ul style="list-style-type: none"> • Single-row angular contact ball bearings accommodate radial load and axial load in one direction. • Bearings with a machined cage are suitable for high-speed applications.
<p>HAR type for high-speed applications</p> 	<ul style="list-style-type: none"> • Compared with the standard type, this type has more balls that are smaller in diameter and are often used in machine tool spindles. For details, see the separately issued catalog for high ability bearings, CAT No.B2006 for High Ability Ball Bearing Series Angular Contact Ball Bearings for Machining Tools.

Reference G-type bearing

"G-type" bearings have a stand-out between the inner ring and outer ring on both sides that are equal in size. This arrangement is called "flush ground processing." These bearings can be matched in a variety of ways.

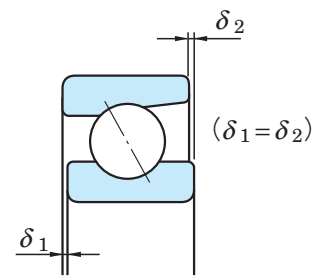
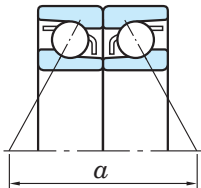
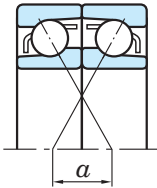
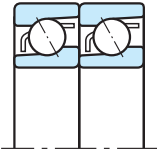

Table 2 Matched pair and stack angular contact ball bearings

<p>Back-to-back arrangement (DB)</p>		<ul style="list-style-type: none"> • Carries radial load and axial load in both directions. • Suitable for applications involving moment loading because the distance between the load centers (α) is long. • As for the preloaded type, the clearance is pre-adjusted so that bearings will be preloaded the proper amount when the inner ring is fixed with a nut.
<p>Face-to-face arrangement (DF)</p>		<ul style="list-style-type: none"> • Carries radial load and axial load in both directions. • Has a smaller moment load accommodating capacity than the back-to-back arrangement, because the distance between the load centers (α) is shorter. • As for the preloaded type, the clearance is pre-adjusted so that bearings will be preloaded the proper amount when the outer rings are pressed together.
<p>Tandem arrangement (DT)</p>		<ul style="list-style-type: none"> • Carries radial load and axial load in one direction. • Suitable for applications which involve a high degree of axial loading.

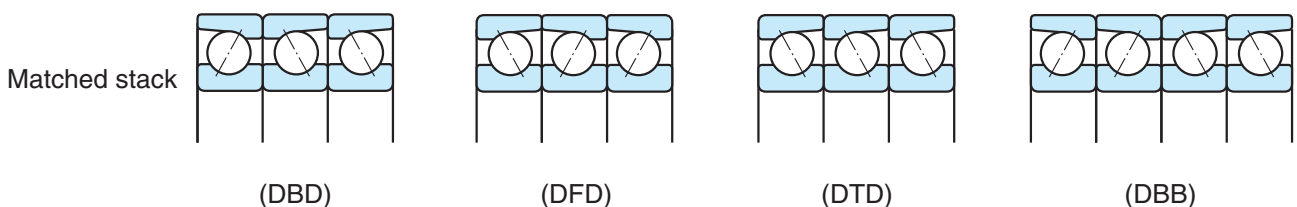
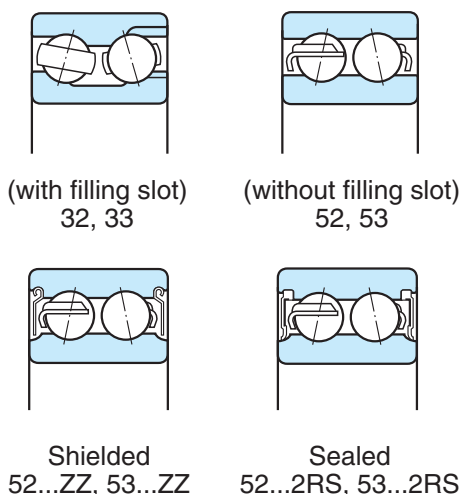

Table 3 Double-row angular contact ball bearings



- Accommodates radial load and axial load in both directions. Also able to accommodate moment load. When installing bearings with filling slot (32 and 33 series), the raceway side without filling slot must accommodate main load.
- The 32 and 33 series are provided with a filling slot, while the 52 and 53 series are not.
32 and 33 series : contact angle 32°
52 and 53 series : contact angle 24°
- Inferior to single-row and matched pair angular contact ball bearings in terms of high-speed and high accuracy performance.
- Shielded or sealed 52 and 53 series bearings are also available.

Boundary dimensions	The dimensions of standard series are as specified in JIS B 1512.																																									
Tolerances	<ul style="list-style-type: none"> • As specified in JIS B 1514-1. (refer to Table 7-3 on pp. A 54 – A 57.) • JTEKT has established "special tolerances" for bore diameter and outside diameter, as listed in the table to the right, to make it easy to produce high-precision matched stack bearings. Bearings which are produced based on these tolerances are identified by the supplementary code "K5." 	<table border="1"> <thead> <tr> <th colspan="6">Special tolerances (K5) Unit : μm</th> </tr> <tr> <th colspan="2" rowspan="2">Nominal bore diameter d (mm)</th> <th colspan="4">Single plane mean bore diameter (Δd_{mp}) or single plane mean outside diameter deviation (ΔD_{mp})</th> </tr> <tr> <th colspan="2">class 5</th> <th colspan="2">class 4</th> </tr> <tr> <th>over</th> <th>up to</th> <th>upper</th> <th>lower</th> <th>upper</th> <th>lower</th> </tr> </thead> <tbody> <tr> <td>-</td> <td>50</td> <td>-1</td> <td>-4</td> <td>-1</td> <td>-3</td> </tr> <tr> <td>50</td> <td>80</td> <td>-1</td> <td>-5</td> <td>-1</td> <td>-4</td> </tr> <tr> <td>80</td> <td>120</td> <td>-1</td> <td>-5</td> <td>-1</td> <td>-4</td> </tr> </tbody> </table>	Special tolerances (K5) Unit : μm						Nominal bore diameter d (mm)		Single plane mean bore diameter (Δd_{mp}) or single plane mean outside diameter deviation (ΔD_{mp})				class 5		class 4		over	up to	upper	lower	upper	lower	-	50	-1	-4	-1	-3	50	80	-1	-5	-1	-4	80	120	-1	-5	-1	-4
Special tolerances (K5) Unit : μm																																										
Nominal bore diameter d (mm)		Single plane mean bore diameter (Δd_{mp}) or single plane mean outside diameter deviation (ΔD_{mp})																																								
		class 5		class 4																																						
over	up to	upper	lower	upper	lower																																					
-	50	-1	-4	-1	-3																																					
50	80	-1	-5	-1	-4																																					
80	120	-1	-5	-1	-4																																					
Internal clearance	<ul style="list-style-type: none"> ■ Matched pair bearing axial internal clearance.....(refer to Table 10-4 on p. A 97.) ■ Double-row bearing radial internal clearance.....(refer to Table 10-5 on p. A 98.) 																																									
Recommended fits	<ul style="list-style-type: none"> ■ Classes 0 and 6 bearings.....(refer to Table 9-4 on pp. A 85, 86.) ■ Classes 5 and 4 bearings.....as listed in the table below. <table border="1"> <thead> <tr> <th colspan="2" rowspan="2">Fit</th> <th>class 5</th> <th>class 4</th> </tr> <tr> <th colspan="2">Tolerance class</th> </tr> </thead> <tbody> <tr> <td rowspan="2">With shaft</td> <td>Inner ring rotation</td> <td>js 5</td> <td>js 4</td> </tr> <tr> <td>Outer ring rotation</td> <td>h 5</td> <td>h 4</td> </tr> <tr> <td rowspan="3">With housing</td> <td>Fixed side</td> <td>JS 6</td> <td>JS 5</td> </tr> <tr> <td>Free side</td> <td>H 6</td> <td>H 5</td> </tr> <tr> <td>Outer ring rotation</td> <td>M 5</td> <td>M 4</td> </tr> </tbody> </table> <ul style="list-style-type: none"> ■ Refer to Table 11-3 on page A 109 for the recommended fits of high-precision matched pair bearings (class 5 and class 4), which are used with light preload (L) or middle preload (M). 		Fit		class 5	class 4	Tolerance class		With shaft	Inner ring rotation	js 5	js 4	Outer ring rotation	h 5	h 4	With housing	Fixed side	JS 6	JS 5	Free side	H 6	H 5	Outer ring rotation	M 5	M 4																	
Fit		class 5			class 4																																					
		Tolerance class																																								
With shaft	Inner ring rotation	js 5	js 4																																							
	Outer ring rotation	h 5	h 4																																							
With housing	Fixed side	JS 6	JS 5																																							
	Free side	H 6	H 5																																							
	Outer ring rotation	M 5	M 4																																							

Standard cages

- Pressed steel cage
(supplementary code : //)
- Copper alloy machined cage
(supplementary code : FY)

[Note] Machine tools are generally equipped with bearings that have a phenolic resin machined cage (FT). Bearings with a polyamide molded cage can also be used depending on the applications. Four-point contact ball bearings usually use a copper alloy machined cage.

Application of standard cages

Bearing series	Pressed cage	Machined cage
79C	—	7900C – 7932C
79CPA	—	7900CPA – 7932CPA
70	—	7000 – 7040
70B	—	7000B – 7040B
70C	—	7000C – 7040C
70CPA	—	7000CPA – 7034CPA
72	7200 – 7220	7200 – 7240
72B	7200B – 7220B	7200B – 7240B
72C	7200C – 7220C	7200C – 7240C
72CPA	—	7200CPA – 7230CPA
73	7300 – 7320	7300 – 7340
73B	7303B – 7320B	7303B – 7340B
73C	7303C – 7320C	7303C – 7334C
74	7405 – 7409	7404 – 7418
74B	7405B – 7409B	7404B – 7418B
HAR9C	—	HAR910C – HAR934C
HAR0C	—	HAR006C – HAR034C
32	3200 – 3215	3216 – 3222
33	3302 – 3313	3314 – 3322
52	5203 – 5214	—
53	5304 – 5315	—

Allowable misalignment

Single-row.....0.000 6 rad (2') : Matched pair, double-row.....misalignment not allowed

Equivalent radial load

[Single-row and matched pair angular contact ball bearings]

[Note]
When two single-row angular contact ball bearings are used facing one another, an axial component of force is produced under radial load. In this case, refer to page A 34 for calculation of the dynamic equivalent radial load.

Dynamic equivalent radial load

$$P_r = X F_r + Y F_a$$

Contact angle	$i f_0 F_a^*$ C_{0r}	e	Single-row and tandem arrangement				Back-to-back and face-to-face arrangement			
			$F_a/F_r \leq e$		$F_a/F_r > e$		$F_a/F_r \leq e$		$F_a/F_r > e$	
			X	Y	X	Y	X	Y	X	Y
15°	0.178	0.38				1.47		1.65		2.39
	0.357	0.40				1.40		1.57		2.28
	0.714	0.43				1.30		1.46		2.11
	1.07	0.46				1.23		1.38		2.00
	1.43	0.47	1	0	0.44	1.19	1	1.34	0.72	1.93
	2.14	0.50				1.12		1.26		1.82
	3.57	0.55				1.02		1.14		1.66
	5.35	0.56				1.00		1.12		1.63
7.14	0.56				1.00		1.12		1.63	
30°	—	0.80	1	0	0.39	0.76	1	0.78	0.63	1.24
40°	—	1.14	1	0	0.35	0.57	1	0.55	0.57	0.93

* For i , use 2 for DB&DF and 1 for single&DT.
Factor f_0 is shown in the bearing dimension table.

Static equivalent radial load

$$P_{0r} = X_0 F_r + Y_0 F_a$$

In reference to single-row and tandem arrangement bearings,

when $P_{0r} < F_r$,
 $P_{0r} = F_r$

Contact angle	Single-row and tandem arrangement		Back-to-back and face-to-face arrangement	
	X_0	Y_0	X_0	Y_0
15°	0.5	0.46	1	0.92
30°	0.5	0.33	1	0.66
40°	0.5	0.26	1	0.52

Equivalent radial load [Double-row angular contact ball bearings]	Dynamic equivalent radial load $P_r = XF_r + YF_a$	<table border="1"> <thead> <tr> <th rowspan="2">Contact angle</th> <th rowspan="2">e</th> <th colspan="2">$F_a/F_r \leq e$</th> <th colspan="2">$F_a/F_r > e$</th> <th rowspan="2">(reference)</th> </tr> <tr> <th>X</th> <th>Y</th> <th>X</th> <th>Y</th> </tr> </thead> <tbody> <tr> <td>24°</td> <td>0.66</td> <td>1</td> <td>0.95</td> <td>0.68</td> <td>1.45</td> <td>52, 53 series</td> </tr> <tr> <td>32°</td> <td>0.86</td> <td>1</td> <td>0.73</td> <td>0.62</td> <td>1.17</td> <td>32, 33 series</td> </tr> </tbody> </table>					Contact angle	e	$F_a/F_r \leq e$		$F_a/F_r > e$		(reference)	X	Y	X	Y	24°	0.66	1	0.95	0.68	1.45	52, 53 series	32°	0.86	1	0.73	0.62	1.17	32, 33 series
	Contact angle	e	$F_a/F_r \leq e$		$F_a/F_r > e$				(reference)																						
			X	Y	X	Y																									
24°	0.66	1	0.95	0.68	1.45	52, 53 series																									
32°	0.86	1	0.73	0.62	1.17	32, 33 series																									
Static equivalent radial load $P_{0r} = X_0 F_r + Y_0 F_a$	<table border="1"> <thead> <tr> <th>Contact angle</th> <th>X_0</th> <th>Y_0</th> <th colspan="2">(reference)</th> </tr> </thead> <tbody> <tr> <td>24°</td> <td>1</td> <td>0.78</td> <td colspan="2">52, 53 series</td> </tr> <tr> <td>32°</td> <td>1</td> <td>0.63</td> <td colspan="2">32, 33 series</td> </tr> </tbody> </table>					Contact angle	X_0	Y_0	(reference)		24°	1	0.78	52, 53 series		32°	1	0.63	32, 33 series												
Contact angle	X_0	Y_0	(reference)																												
24°	1	0.78	52, 53 series																												
32°	1	0.63	32, 33 series																												

[Note] In angular contact ball bearings, slippage occurs between the balls and raceways under too small a load, causing smearing to develop. Matched pair bearings may develop smearing when the ratio of the axial load to the radial load exceeds the value of e ($F_a / F_r > e$), as listed in the specification table. Consult with JTEKT when these bearings are used under the above conditions.

[Reference] Relationship between axial load and axial displacement

Diagrams (1) to (9) illustrate the relationship between axial load and axial displacement.

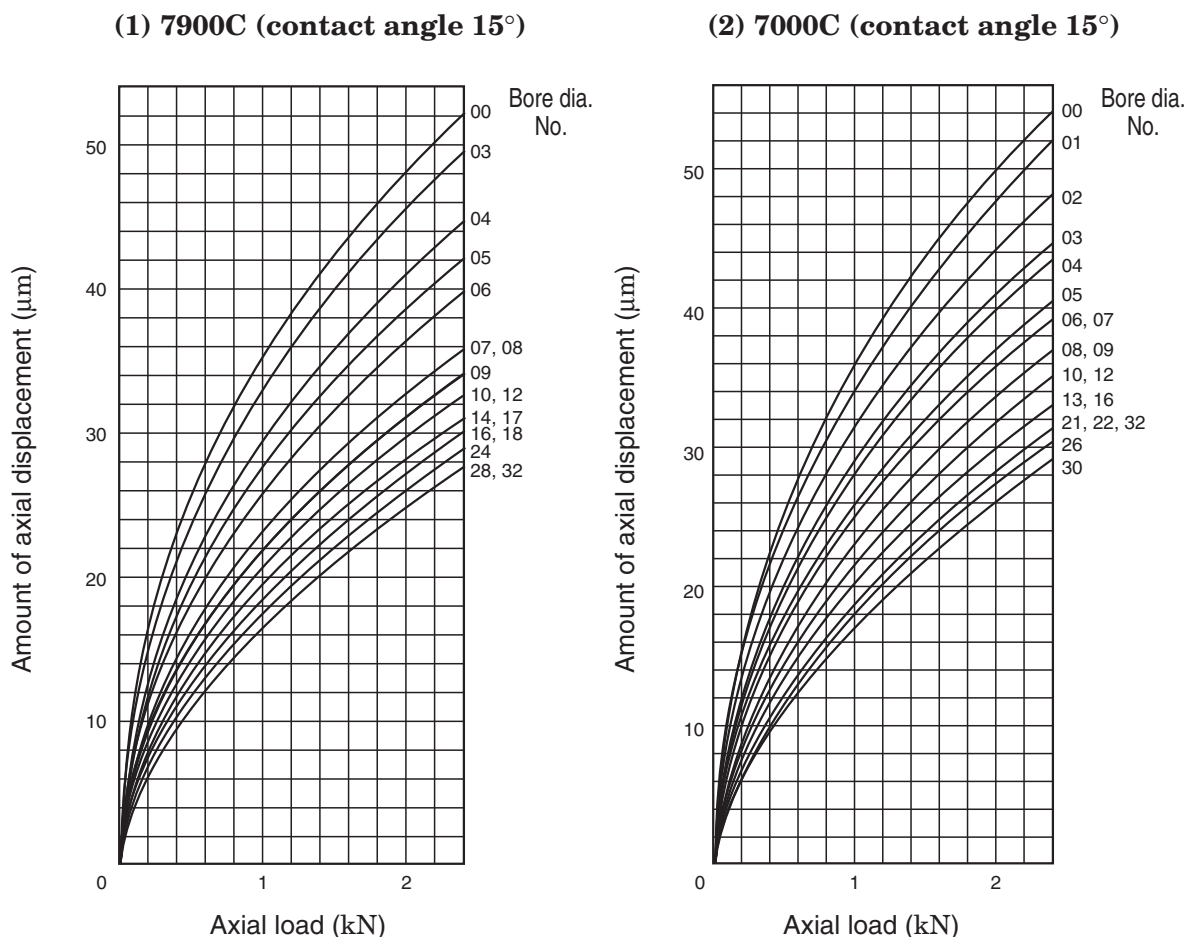

(3) 7200C (contact angle 15°)

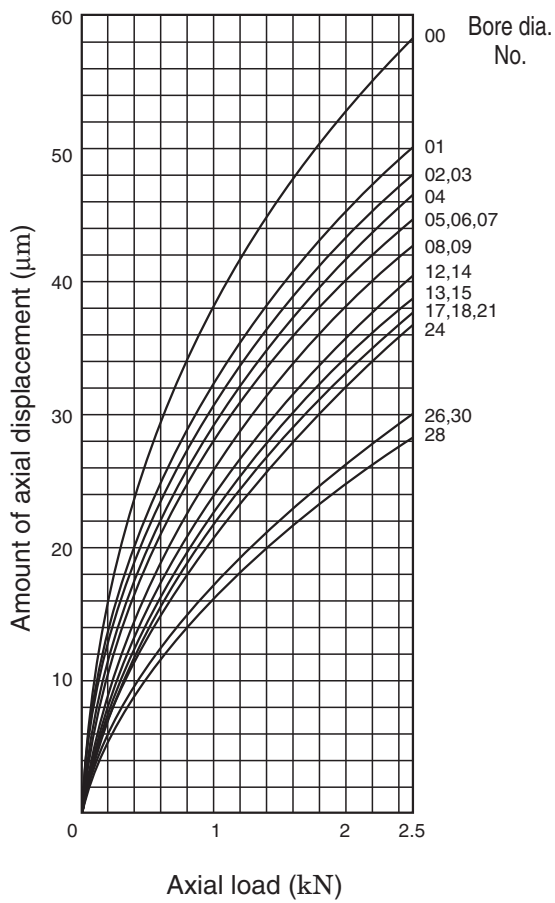

(4) 7000 (contact angle 30°)

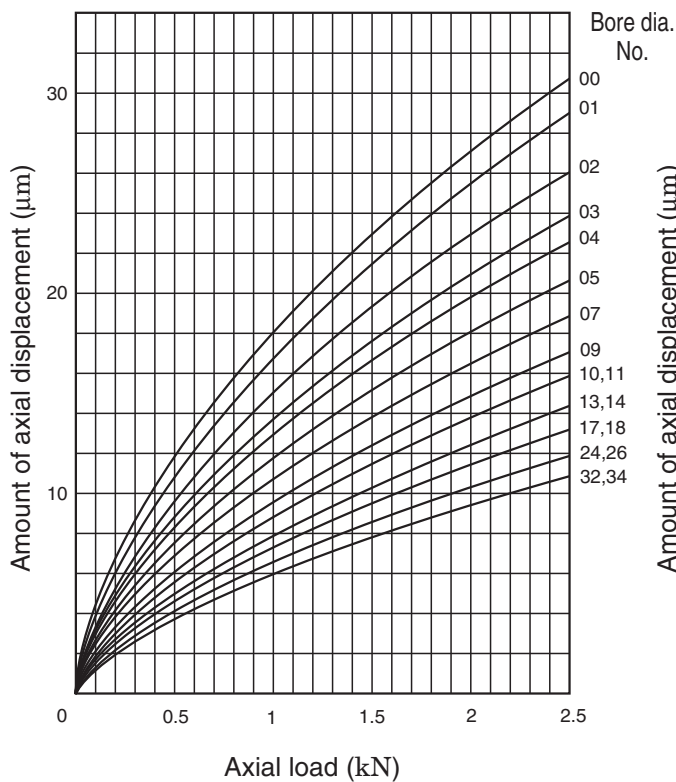

(5) 7200 (contact angle 30°)

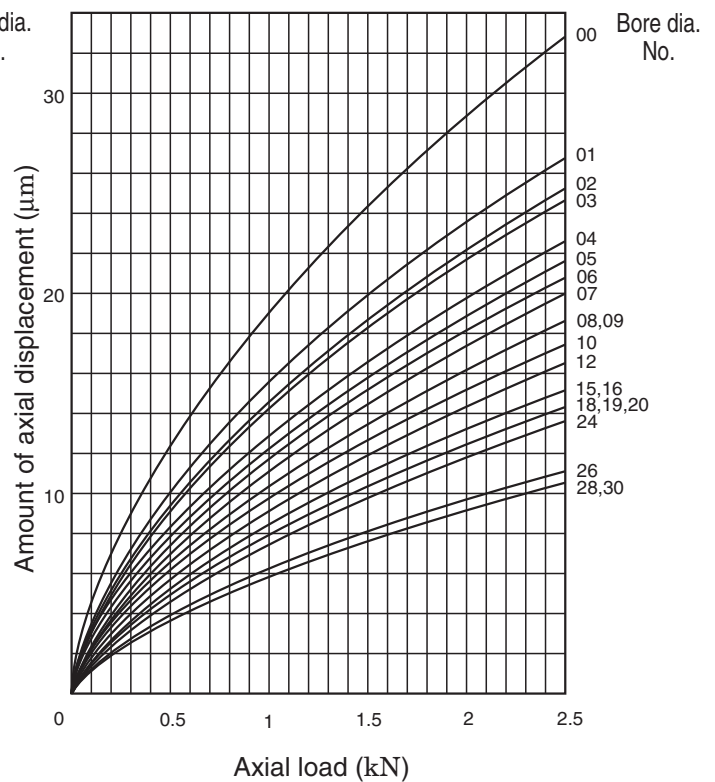

(6) 7000B (contact angle 40°)

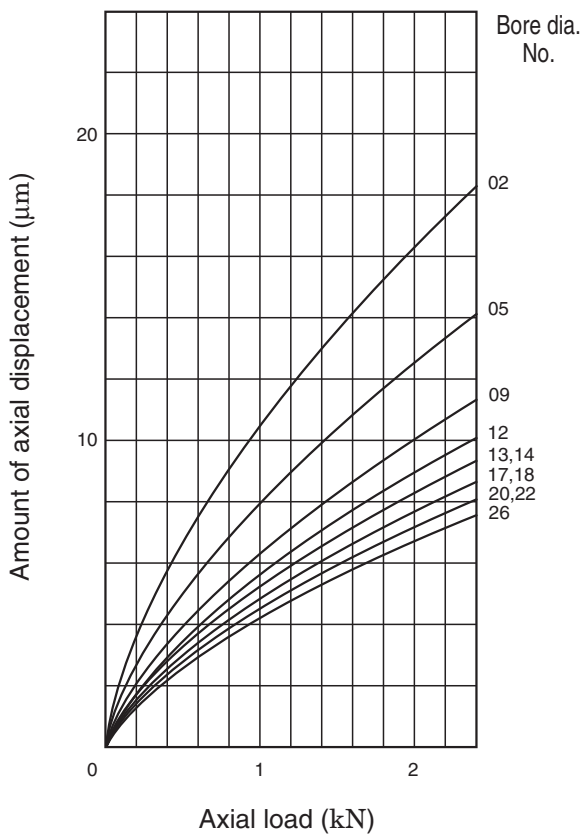

(7) 7200B (contact angle 40°)

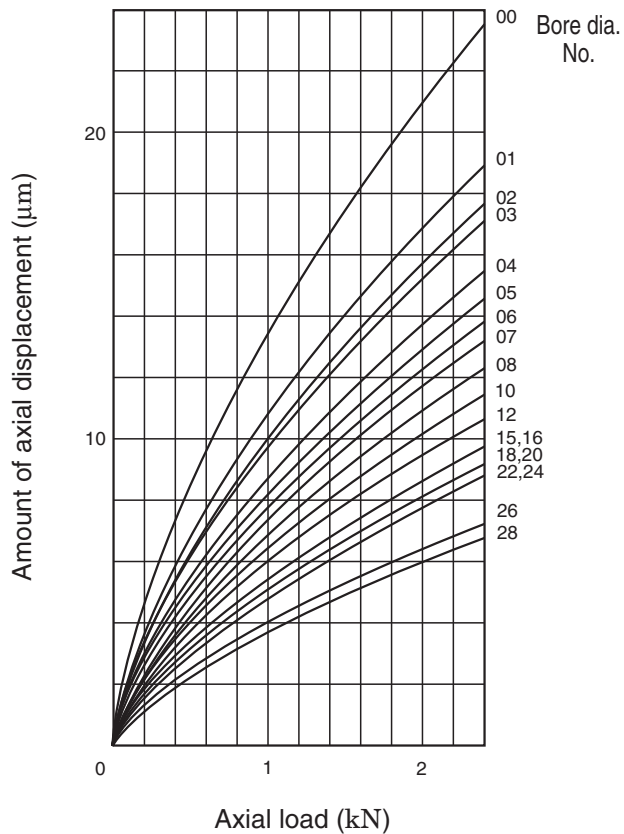

(8) HAR900C (contact angle 15°)

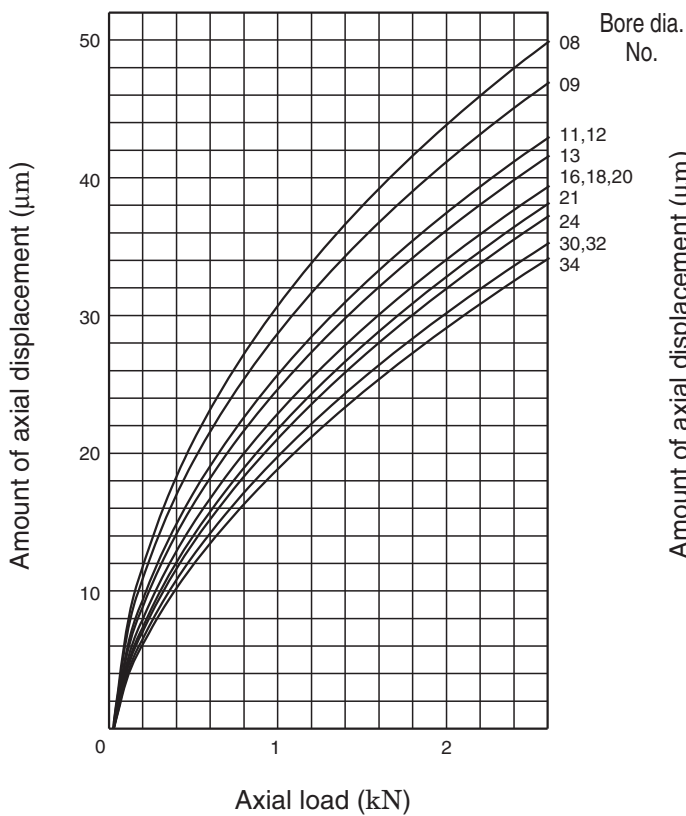

(9) HAR000C (contact angle 15°)

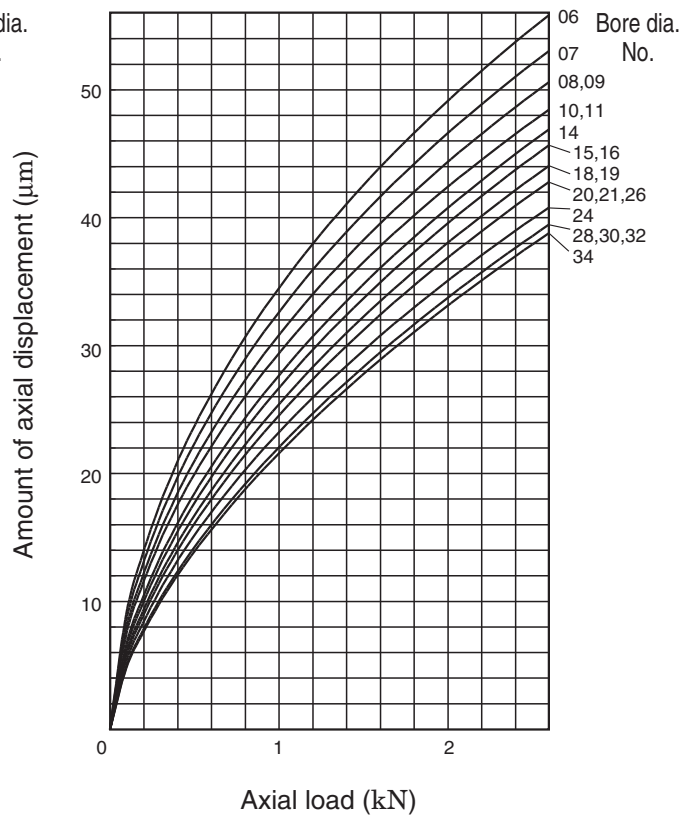

Single-row angular contact ball bearings

d 10 ~ (17) mm

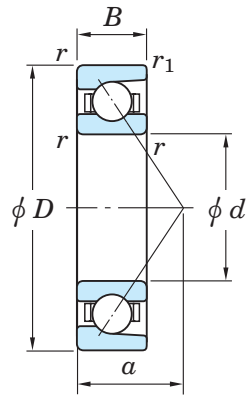

With machined cage

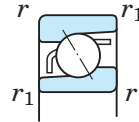

With pressed cage

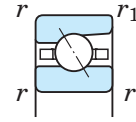

HAR

Boundary dimensions (mm)					Basic load ratings (kN)				Factor	Limiting speeds ¹⁾ (min ⁻¹)	
d	D	B	$r_{\min.}$	$r_{1\min.}$	With machined cage		With pressed cage			f_0	Grease lub.
10	22	6	0.3	0.15	3.00	1.50	—	—	14.2	52 000	69 000
	26	8	0.3	0.15	5.00	2.35	—	—	—	34 000	42 000
	26	8	0.3	0.15	4.65	2.15	—	—	—	25 000	33 000
	26	8	0.3	0.15	5.30	2.45	—	—	12.5	47 000	62 000
	30	9	0.6	0.3	4.65	2.20	5.40	2.75	—	29 000	37 000
	30	9	0.6	0.3	4.30	2.00	4.95	2.50	—	22 000	29 000
	30	9	0.6	0.3	5.00	2.35	5.80	2.95	13.4	40 000	54 000
	35	11	0.6	0.3	8.50	3.75	9.30	4.30	—	27 000	33 000
12	24	6	0.3	0.15	3.20	1.70	—	—	14.7	48 000	62 000
	28	8	0.3	0.15	5.40	2.75	—	—	—	29 000	37 000
	28	8	0.3	0.15	4.95	2.50	—	—	—	22 000	29 000
	28	8	0.3	0.15	5.80	2.95	—	—	13.4	40 000	54 000
	32	10	0.6	0.3	7.45	3.65	8.00	4.05	—	27 000	34 000
	32	10	0.6	0.3	6.95	3.40	7.40	3.75	—	20 000	27 000
	32	10	0.6	0.3	7.90	3.85	8.50	4.30	12.5	38 000	50 000
	37	12	1	0.6	10.2	4.60	11.2	5.25	—	24 000	31 000
15	28	7	0.3	0.15	4.75	2.65	—	—	14.5	39 000	52 000
	32	9	0.3	0.15	6.10	3.45	—	—	—	26 000	32 000
	32	9	0.3	0.15	5.55	3.15	—	—	—	19 000	25 000
	32	9	0.3	0.15	6.60	3.70	—	—	14.1	35 000	47 000
	35	11	0.6	0.3	8.10	4.25	8.10	4.25	—	24 000	29 000
	35	11	0.6	0.3	7.45	3.95	7.45	3.95	—	18 000	24 000
	35	11	0.6	0.3	8.65	4.55	8.65	4.55	13.3	33 000	43 000
	42	13	1	0.6	12.5	6.45	13.4	7.20	—	20 000	25 000
17	30	7	0.3	0.15	5.00	2.95	—	—	14.9	36 000	47 000
	35	10	0.3	0.15	6.75	4.15	—	—	—	23 000	28 000

[Notes] 1) Limiting speeds shown above are applicable to machined cage bearings.
 Limiting speeds of pressed cage bearings should be kept to under 80% of this value.
 For bearings with 15° contact angle, this figure is applied to the high precision bearings ranked higher than class 5, used with machined cage or molded cage.

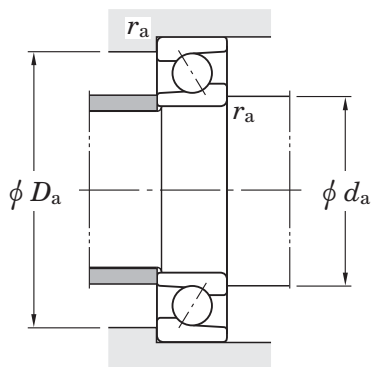

Bearing No. ²⁾	Load center (mm) <i>a</i>	Mounting dimensions (mm)			(Refer.) Mass (kg)
		<i>d_a</i> min.	<i>D_a</i> max.	<i>r_a</i> max.	
7900C	5.1	12.5	19.5	0.3	0.008
7000	9.1	12.5	23.5	0.3	0.021
7000B	11.6	12.5	23.5	0.3	0.021
7000C	6.4	12.5	23.5	0.3	0.021
7200	10.4	14.5	25.5	0.6	0.031
7200B	13.1	14.5	25.5	0.6	0.031
7200C	7.2	14.5	25.5	0.6	0.031
7300	12.0	14.5	30.5	0.6	0.054
7901C	5.4	14.5	21.5	0.3	0.010
7001	9.9	14.5	25.5	0.3	0.024
7001B	12.6	14.5	25.5	0.3	0.024
7001C	6.7	14.5	25.5	0.3	0.024
7201	11.4	16.5	27.5	0.6	0.038
7201B	14.2	16.5	27.5	0.6	0.038
7201C	7.9	16.5	27.5	0.6	0.038
7301	13.1	17.5	31.5	1	0.065
7902C	6.4	17.5	25.5	0.3	0.015
7002	11.3	17.5	29.5	0.3	0.035
7002B	14.6	17.5	29.5	0.3	0.035
7002C	7.6	17.5	29.5	0.3	0.035
7202	12.9	19.5	30.5	0.6	0.048
7202B	16.2	19.5	30.5	0.6	0.048
7202C	8.9	19.5	30.5	0.6	0.048
7302	15.0	20.5	36.5	1	0.088
7903C	6.7	19.5	27.5	0.3	0.016
7003	12.7	19.5	32.5	0.3	0.045

2) B, C or no indication after the bearing number indicates nominal contact angle of 40°, 15° and 30° respectively.

[Remark] Standard cage types used for the above bearings are described earlier in this section.

Single-row angular contact ball bearings

d (17) ~ (25) mm

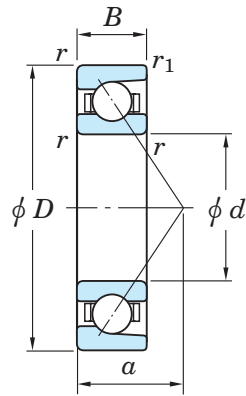

With machined cage

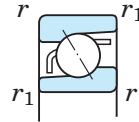

With pressed cage

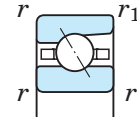

HAR

Boundary dimensions (mm)					Basic load ratings (kN)				Factor	Limiting speeds ¹⁾ (min ⁻¹)	
d	D	B	$r_{\min.}$	$r_{1\min.}$	With machined cage		With pressed cage			f_0	Grease lub.
					C_r	C_{0r}	C_r	C_{0r}			
17	35	10	0.3	0.15	6.10	3.75	—	—	—	17 000	23 000
	35	10	0.3	0.15	7.30	4.45	—	—	14.6	31 000	41 000
	40	12	0.6	0.3	10.2	5.50	10.2	5.50	—	21 000	26 000
	40	12	0.6	0.3	9.35	5.05	9.35	5.05	—	16 000	21 000
	40	12	0.6	0.3	10.9	5.90	10.9	5.90	13.4	29 000	38 000
	47	14	1	0.6	14.9	7.90	16.0	8.75	—	18 000	23 000
	47	14	1	0.6	13.8	7.30	14.8	8.10	—	14 000	18 000
47	14	1	0.6	15.8	8.40	15.8	8.40	12.6	25 000	33 000	
20	37	9	0.3	0.15	7.30	4.55	—	—	14.9	30 000	39 000
	42	12	0.6	0.3	10.3	6.10	—	—	—	19 000	24 000
	42	12	0.6	0.3	9.35	5.55	—	—	—	14 000	19 000
	42	12	0.6	0.3	11.1	6.60	—	—	14.1	26 000	35 000
	47	14	1	0.6	14.5	8.40	15.4	9.15	—	17 000	22 000
	47	14	1	0.6	13.3	7.70	14.1	8.40	—	13 000	17 000
	47	14	1	0.6	15.5	9.00	16.5	9.80	13.4	24 000	32 000
	52	15	1.1	0.6	17.4	9.40	18.7	10.4	—	17 000	21 000
	52	15	1.1	0.6	16.2	8.70	17.3	9.65	—	13 000	17 000
	52	15	1.1	0.6	18.5	9.95	19.9	11.1	12.6	23 000	31 000
	72	19	1.1	0.6	35.6	19.1	—	—	—	9 600	13 000
72	19	1.1	0.6	33.5	17.9	—	—	—	8 500	12 000	
25	42	9	0.3	0.15	7.80	5.45	—	—	15.5	25 000	33 000
	47	12	0.6	0.3	11.3	7.40	—	—	—	17 000	21 000
	47	12	0.6	0.3	10.2	6.70	—	—	—	12 000	17 000
	47	12	0.6	0.3	12.3	8.00	—	—	14.7	23 000	30 000
	52	15	1	0.6	15.3	9.50	16.2	10.3	—	15 000	19 000
	52	15	1	0.6	14.0	8.70	14.7	9.40	—	12 000	15 000
	52	15	1	0.6	16.6	10.2	17.5	11.1	14.0	21 000	28 000

[Notes] 1) Limiting speeds shown above are applicable to machined cage bearings. Limiting speeds of pressed cage bearings should be kept to under 80% of this value. For bearings with 15° contact angle, this figure is applied to the high precision bearings ranked higher than class 5, used with machined cage or molded cage.

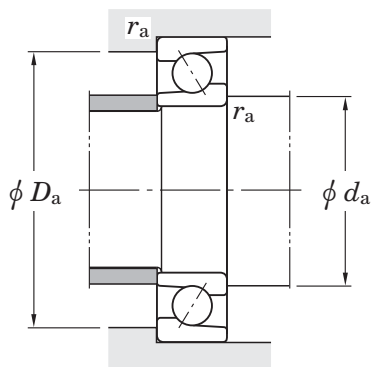

Bearing No. ²⁾	Load center (mm) a	Mounting dimensions (mm)			(Refer.) Mass (kg)
		d_a min.	D_a max.	r_a max.	
7003B	16.1	19.5	32.5	0.3	0.045
7003C	8.6	19.5	32.5	0.3	0.045
7203	14.4	21.5	35.5	0.6	0.070
7203B	18.2	21.5	35.5	0.6	0.070
7203C	9.9	21.5	35.5	0.6	0.070
7303	16.5	22.5	41.5	1	0.120
7303B	20.8	22.5	41.5	1	0.120
7303C	11.4	22.5	41.5	1	0.120
7904C	8.3	22.5	34.5	0.3	0.035
7004	15.1	24.5	37.5	0.6	0.079
7004B	19.2	24.5	37.5	0.6	0.079
7004C	10.2	24.5	37.5	0.6	0.079
7204	17.0	25.5	41.5	1	0.112
7204B	21.5	25.5	41.5	1	0.112
7204C	11.6	25.5	41.5	1	0.112
7304	17.9	27	45	1	0.150
7304B	22.6	27	45	1	0.150
7304C	12.3	27	45	1	0.150
7404	23.1	27	65	1	0.395
7404B	29.2	27	65	1	0.395
7905C	9.1	27.5	39.5	0.3	0.041
7005	16.4	29.5	42.5	0.6	0.091
7005B	21.1	29.5	42.5	0.6	0.091
7005C	10.8	29.5	42.5	0.6	0.091
7205	18.8	30.5	46.5	1	0.135
7205B	23.9	30.5	46.5	1	0.135
7205C	12.7	30.5	46.5	1	0.135

2) B, C or no indication after the bearing number indicates nominal contact angle of 40°, 15° and 30° respectively.

[Remark] Standard cage types used for the above bearings are described earlier in this section.

Single-row angular contact ball bearings

d (25) ~ (35) mm

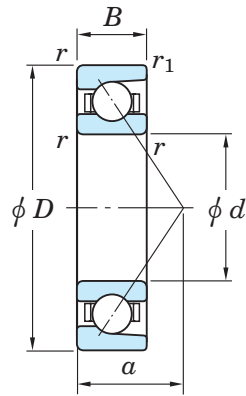

With machined cage

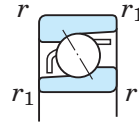

With pressed cage

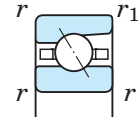

HAR

Boundary dimensions (mm)					Basic load ratings (kN)				Factor	Limiting speeds ¹⁾ (min ⁻¹)	
d	D	B	$r_{\min.}$	$r_{1\min.}$	With machined cage		With pressed cage			f_0	Grease lub.
					C_r	C_{0r}	C_r	C_{0r}			
25	62	17	1.1	0.6	24.8	14.4	26.4	15.8	—	14 000	17 000
	62	17	1.1	0.6	22.9	13.3	24.4	14.6	—	10 000	14 000
	62	17	1.1	0.6	26.4	15.3	28.1	16.8	12.8	19 000	25 000
	80	21	1.5	1	39.7	23.2	42.6	25.7	—	8 200	11 000
	80	21	1.5	1	36.9	21.5	39.6	23.9	—	7 300	10 000
30	47	9	0.3	0.15	8.30	6.25	—	—	15.9	22 000	29 000
	55	13	1	0.6	8.70	4.85	—	—	7.9	26 000	40 000
	55	13	1	0.6	14.5	10.1	—	—	—	14 000	18 000
	55	13	1	0.6	13.1	9.20	—	—	—	11 000	14 000
	55	13	1	0.6	15.8	11.0	—	—	14.9	20 000	26 000
	62	16	1	0.6	21.3	13.7	22.5	14.8	—	13 000	16 000
	62	16	1	0.6	19.4	12.5	20.5	13.6	—	9 600	13 000
	62	16	1	0.6	23.0	14.7	24.3	16.0	14.0	18 000	24 000
	72	19	1.1	0.6	30.1	18.9	31.9	20.6	—	12 000	14 000
	72	19	1.1	0.6	27.6	17.4	29.3	19.0	—	8 700	12 000
	72	19	1.1	0.6	32.3	20.3	34.2	22.1	13.4	16 000	21 000
	90	23	1.5	1	47.6	28.4	51.0	31.6	—	7 300	9 700
	90	23	1.5	1	44.2	26.4	47.4	29.3	—	6 500	8 900
35	55	10	0.6	0.3	12.5	9.70	—	—	15.7	19 000	25 000
	62	14	1	0.6	9.25	5.55	—	—	8.1	23 000	35 000
	62	14	1	0.6	17.5	12.6	—	—	—	12 000	15 000
	62	14	1	0.6	15.8	11.4	—	—	—	9 200	12 000
	62	14	1	0.6	19.1	13.7	—	—	15.0	17 000	22 000
	72	17	1.1	0.6	28.1	18.6	29.7	20.2	—	11 000	14 000
	72	17	1.1	0.6	25.6	17.0	27.0	18.5	—	8 300	11 000
	72	17	1.1	0.6	30.4	20.1	32.1	21.7	14.0	15 000	20 000
	80	21	1.5	1	35.4	22.0	39.9	26.4	—	10 000	13 000

[Notes] 1) Limiting speeds shown above are applicable to machined cage bearings. Limiting speeds of pressed cage bearings should be kept to under 80% of this value. For bearings with 15° contact angle, this figure is applied to the high precision bearings ranked higher than class 5, used with machined cage or molded cage.

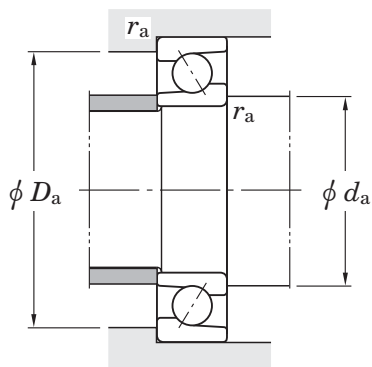

Bearing No. ²⁾	Load center (mm) <i>a</i>	Mounting dimensions (mm)			(Refer.) Mass (kg)
		<i>d_a</i> min.	<i>D_a</i> max.	<i>r_a</i> max.	
7305	21.1	32	55	1	0.243
7305B	26.8	32	55	1	0.243
7305C	14.3	32	55	1	0.243
7405	26.4	33.5	71.5	1.5	0.527
7405B	33.6	33.5	71.5	1.5	0.527
7906C	9.7	32.5	44.5	0.3	0.046
HAR006C	12.2	35.5	49.5	1	0.116
7006	18.8	35.5	49.5	1	0.133
7006B	24.3	35.5	49.5	1	0.133
7006C	12.2	35.5	49.5	1	0.133
7206	21.5	35.5	56.5	1	0.208
7206B	27.6	35.5	56.5	1	0.208
7206C	14.3	35.5	56.5	1	0.208
7306	24.5	37	65	1	0.362
7306B	31.3	37	65	1	0.362
7306C	16.5	37	65	1	0.362
7406	29.3	38.5	81.5	1.5	0.686
7406B	37.3	38.5	81.5	1.5	0.686
7907C	11.0	39.5	50.5	0.6	0.074
HAR007C	13.5	40.5	56.5	1	0.158
7007	21.2	40.5	56.5	1	0.170
7007B	27.6	40.5	56.5	1	0.170
7007C	13.5	40.5	56.5	1	0.170
7207	24.2	42	65	1	0.295
7207B	31.4	42	65	1	0.295
7207C	15.8	42	65	1	0.295
7307	27.4	43.5	71.5	1.5	0.475

2) B, C or no indication after the bearing number indicates nominal contact angle of 40°, 15° and 30° respectively.

[Remark] Standard cage types used for the above bearings are described earlier in this section.

Single-row angular contact ball bearings

d (35) ~ (45) mm

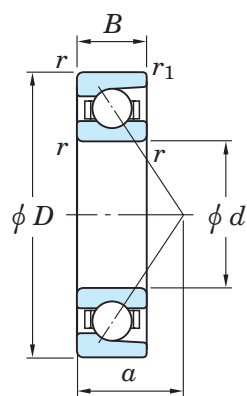

With machined cage

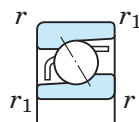

With pressed cage

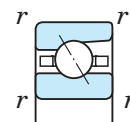

HAR

Boundary dimensions (mm)					Basic load ratings (kN)				Factor	Limiting speeds ¹⁾ (min ⁻¹)	
d	D	B	$r_{\min.}$	$r_{1\min.}$	With machined cage		With pressed cage			f_0	Grease lub.
					C_r	C_{0r}	C_r	C_{0r}			
35	80	21	1.5	1	32.5	20.2	36.6	24.3	—	7 700	10 000
	80	21	1.5	1	37.9	23.6	42.8	28.3	13.4	14 000	19 000
	100	25	1.5	1	60.4	37.0	64.8	41.1	—	6 500	8 600
	100	25	1.5	1	56.2	34.3	60.2	38.1	—	5 700	7 900
40	62	12	0.6	0.3	15.7	12.4	—	—	15.7	17 000	22 000
	62	12	0.6	0.3	6.35	4.05	—	—	8.4	22 000	33 000
	68	15	1	0.6	9.70	6.20	—	—	8.2	20 000	31 000
	68	15	1	0.6	18.7	14.6	—	—	—	11 000	14 000
	68	15	1	0.6	16.8	13.2	—	—	—	8 300	11 000
	68	15	1	0.6	20.5	15.9	—	—	15.4	15 000	20 000
	80	18	1.1	0.6	33.6	23.3	35.3	25.1	—	10 000	12 000
	80	18	1.1	0.6	30.6	21.3	32.1	23.0	—	7 500	10 000
	80	18	1.1	0.6	36.4	25.2	38.2	27.1	14.2	14 000	18 000
	90	23	1.5	1	43.2	27.4	48.8	32.9	—	9 200	12 000
	90	23	1.5	1	39.7	25.2	44.8	30.3	—	6 900	9 200
	90	23	1.5	1	46.3	29.4	52.3	35.3	13.4	13 000	17 000
	110	27	2	1	69.9	43.5	75.0	48.4	—	5 900	7 900
	110	27	2	1	64.9	40.4	69.6	44.9	—	5 200	7 200
45	68	12	0.6	0.3	16.6	14.1	—	—	16.0	15 000	20 000
	68	12	0.6	0.3	6.80	4.70	—	—	8.5	19 000	30 000
	75	16	1	0.6	10.9	7.10	—	—	8.3	18 000	28 000
	75	16	1	0.6	22.2	17.7	—	—	—	10 000	12 000
	75	16	1	0.6	20.0	16.0	—	—	—	7 500	10 000
	75	16	1	0.6	24.4	19.3	—	—	15.4	14 000	18 000
	85	19	1.1	0.6	37.7	26.6	39.6	28.6	—	9 400	12 000
	85	19	1.1	0.6	34.3	24.3	36.1	26.1	—	7 000	9 400
	85	19	1.1	0.6	40.8	28.7	42.9	30.9	14.2	13 000	17 000

[Notes] 1) Limiting speeds shown above are applicable to machined cage bearings.
 Limiting speeds of pressed cage bearings should be kept to under 80% of this value.
 For bearings with 15° contact angle, this figure is applied to the high precision bearings ranked higher than class 5, used with machined cage or molded cage.

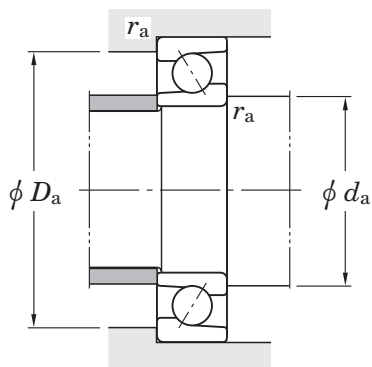

Bearing No. ²⁾	Load center (mm) <i>a</i>	Mounting dimensions (mm)			(Refer.) Mass (kg)
		<i>d_a</i> min.	<i>D_a</i> max.	<i>r_a</i> max.	
7307B	35.0	43.5	71.5	1.5	0.475
7307C	18.3	43.5	71.5	1.5	0.475
7407	32.6	43.5	91.5	1.5	0.950
7407B	41.7	43.5	91.5	1.5	0.950
7908C	12.8	44.5	57.5	0.6	0.107
HAR908C	12.8	44.5	57.5	0.6	0.115
HAR008C	14.7	45.5	62.5	1	0.200
7008	23.2	45.5	62.5	1	0.210
7008B	30.2	45.5	62.5	1	0.210
7008C	14.8	45.5	62.5	1	0.210
7208	26.3	47	73	1	0.382
7208B	34.2	47	73	1	0.382
7208C	17.0	47	73	1	0.382
7308	30.3	48.5	81.5	1.5	0.657
7308B	38.8	48.5	81.5	1.5	0.657
7308C	20.2	48.5	81.5	1.5	0.657
7408	35.5	50	100	2	1.23
7408B	45.4	50	100	2	1.23
7909C	13.6	49.5	63.5	0.6	0.127
HAR909C	13.6	49.5	63.5	0.6	0.136
HAR009C	16.0	50.5	69.5	1	0.251
7009	25.3	50.5	69.5	1	0.260
7009B	33.2	50.5	69.5	1	0.260
7009C	16.0	50.5	69.5	1	0.260
7209	28.0	52	78	1	0.430
7209B	36.4	52	78	1	0.430
7209C	18.1	52	78	1	0.430

2) B, C or no indication after the bearing number indicates nominal contact angle of 40°, 15° and 30° respectively.

[Remark] Standard cage types used for the above bearings are described earlier in this section.

Single-row angular contact ball bearings

d (45) ~ (55) mm

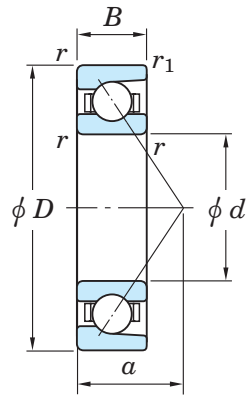

With machined cage

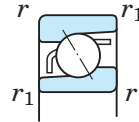

With pressed cage

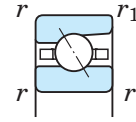

HAR

Boundary dimensions (mm)					Basic load ratings (kN)				Factor	Limiting speeds ¹⁾ (min ⁻¹)	
d	D	B	$r_{\min.}$	$r_{1\min.}$	With machined cage		With pressed cage			f_0	Grease lub.
					C_r	C_{0r}	C_r	C_{0r}			
45	100	25	1.5	1	55.1	37.1	58.4	40.4	—	8 200	10 000
	100	25	1.5	1	50.6	34.1	53.6	37.2	—	6 200	8 200
	100	25	1.5	1	59.2	39.7	62.7	43.4	13.5	11 000	15 000
	120	29	2	1	84.9	53.8	91.1	59.8	—	5 400	7 100
	120	29	2	1	78.9	50.0	84.7	55.5	—	4 800	6 600
50	72	12	0.6	0.3	17.4	15.7	—	—	16.2	14 000	18 000
	72	12	0.6	0.3	9.10	6.30	—	—	8.5	18 000	28 000
	80	16	1	0.6	11.4	7.85	—	—	8.4	17 000	26 000
	80	16	1	0.6	23.6	20.1	—	—	—	9 200	11 000
	80	16	1	0.6	21.2	18.1	—	—	—	6 900	9 200
	80	16	1	0.6	26.0	21.9	—	—	15.7	13 000	17 000
	90	20	1.1	0.6	39.4	29.4	41.3	31.5	—	8 500	11 000
	90	20	1.1	0.6	35.7	26.7	37.4	28.6	—	6 400	8 500
	90	20	1.1	0.6	42.8	31.8	44.8	34.1	14.6	12 000	16 000
	110	27	2	1	70.1	48.1	74.3	52.5	—	7 300	9 100
	110	27	2	1	64.4	44.3	68.2	48.3	—	5 500	7 300
	110	27	2	1	75.1	51.6	79.6	56.2	13.4	10 000	13 000
	130	31	2.1	1.1	97.4	65.3	—	—	—	4 900	6 600
130	31	2.1	1.1	90.2	60.4	—	—	—	4 400	6 000	
55	80	13	1	0.6	19.7	18.5	—	—	16.3	13 000	17 000
	80	13	1	0.6	10.1	7.65	—	—	8.6	16 000	25 000
	90	18	1.1	0.6	14.1	9.90	—	—	8.4	15 000	23 000
	90	18	1.1	0.6	31.1	26.3	—	—	—	8 300	10 000
	90	18	1.1	0.6	27.9	23.7	—	—	—	6 200	8 300
	90	18	1.1	0.6	34.1	28.6	—	—	15.5	11 000	15 000
	100	21	1.5	1	48.7	37.1	51.0	39.8	—	7 600	9 500
	100	21	1.5	1	44.1	33.8	46.2	36.2	—	5 700	7 600

[Notes] 1) Limiting speeds shown above are applicable to machined cage bearings. Limiting speeds of pressed cage bearings should be kept to under 80% of this value. For bearings with 15° contact angle, this figure is applied to the high precision bearings ranked higher than class 5, used with machined cage or molded cage.

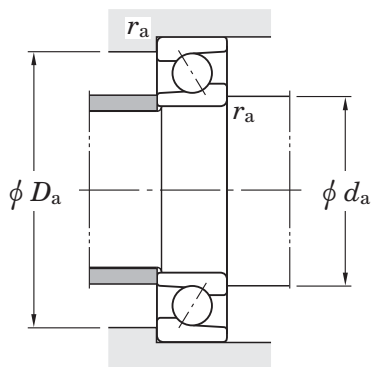

Bearing No. ²⁾	Load center (mm) <i>a</i>	Mounting dimensions (mm)			(Refer.) Mass (kg)
		<i>d_a</i> min.	<i>D_a</i> max.	<i>r_a</i> max.	
7309	33.6	53.5	91.5	1.5	0.875
7309B	43.1	53.5	91.5	1.5	0.875
7309C	22.3	53.5	91.5	1.5	0.875
7409	38.6	55	110	2	1.55
7409B	49.5	55	110	2	1.55
7910C	14.2	54.5	67.5	0.6	0.128
HAR910C	14.2	54.5	67.5	0.6	0.131
HAR010C	16.7	55.5	74.5	1	0.273
7010	26.9	55.5	74.5	1	0.290
7010B	35.3	55.5	74.5	1	0.290
7010C	16.8	55.5	74.5	1	0.290
7210	30.4	57	83	1	0.485
7210B	39.6	57	83	1	0.485
7210C	19.4	57	83	1	0.485
7310	37.2	60	100	2	1.14
7310B	47.9	60	100	2	1.14
7310C	24.5	60	100	2	1.14
7410	41.6	62	118	2	1.92
7410B	53.5	62	118	2	1.92
7911C	15.5	60.5	74.5	1	0.178
HAR911C	15.5	60.5	74.5	1	0.189
HAR011C	18.7	62	83	1	0.403
7011	29.9	62	83	1	0.420
7011B	39.4	62	83	1	0.420
7011C	18.7	62	83	1	0.420
7211	33.3	63.5	91.5	1.5	0.635
7211B	43.6	63.5	91.5	1.5	0.635

2) B, C or no indication after the bearing number indicates nominal contact angle of 40°, 15° and 30° respectively.

[Remark] Standard cage types used for the above bearings are described earlier in this section.

Single-row angular contact ball bearings

d (55) ~ (65) mm

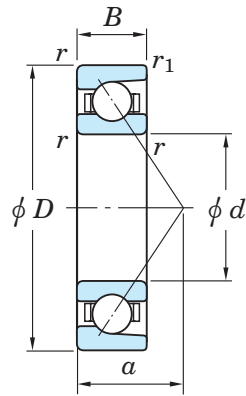

With machined cage

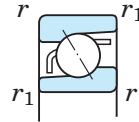

With pressed cage

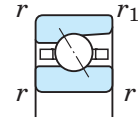

HAR

Boundary dimensions (mm)					Basic load ratings (kN)				Factor f_0	Limiting speeds ¹⁾ (min ⁻¹)	
d	D	B	$r_{\min.}$	$r_{1\min.}$	With machined cage		With pressed cage			Grease lub.	Oil lub.
					C_r	C_{0r}	C_r	C_{0r}			
55	100	21	1.5	1	52.9	40.2	55.4	43.1	14.6	11 000	14 000
	120	29	2	1	80.9	56.5	85.8	61.7	—	6 700	8 400
	120	29	2	1	74.3	52.0	78.7	56.7	—	5 000	6 700
	120	29	2	1	86.8	60.6	91.9	66.1	13.4	9 300	12 000
	140	33	2.1	1.1	118	82.4	—	—	—	4 500	6 000
	140	33	2.1	1.1	110	76.5	—	—	—	4 000	5 500
60	85	13	1	0.6	23.2	21.8	—	—	16.3	12 000	16 000
	85	13	1	0.6	9.95	7.75	—	—	8.6	15 000	23 000
	95	18	1.1	0.6	14.7	10.8	—	—	8.5	14 000	22 000
	95	18	1.1	0.6	31.9	28.1	—	—	—	7 700	9 700
	95	18	1.1	0.6	28.6	25.3	—	—	—	5 800	7 700
	95	18	1.1	0.6	35.0	30.6	—	—	15.7	11 000	14 000
	110	22	1.5	1	58.9	45.7	61.7	49.0	—	6 900	8 600
	110	22	1.5	1	53.4	41.6	55.9	44.6	—	5 100	6 900
	110	22	1.5	1	64.0	49.5	67.0	53.0	14.5	9 500	13 000
	130	31	2.1	1.1	92.5	65.6	98.1	71.6	—	6 200	7 700
	130	31	2.1	1.1	84.9	60.3	90.0	65.8	—	4 600	6 200
	130	31	2.1	1.1	99.2	70.3	105	76.7	13.4	8 600	11 000
	150	35	2.1	1.1	129	93.6	—	—	—	4 100	5 500
	150	35	2.1	1.1	119	86.7	—	—	—	3 700	5 100
65	90	13	1	0.6	20.8	21.2	—	—	16.5	11 000	15 000
	90	13	1	0.6	11.8	9.45	—	—	8.6	14 000	22 000
	100	18	1.1	0.6	15.3	11.8	—	—	8.5	13 000	21 000
	100	18	1.1	0.6	33.7	31.4	—	—	—	7 200	9 000
	100	18	1.1	0.6	30.1	28.3	—	—	—	5 400	7 200
	100	18	1.1	0.6	37.1	34.3	—	—	15.9	10 000	13 000
	120	23	1.5	1	67.3	54.2	70.2	57.8	—	6 400	8 000

[Notes] 1) Limiting speeds shown above are applicable to machined cage bearings. Limiting speeds of pressed cage bearings should be kept to under 80% of this value. For bearings with 15° contact angle, this figure is applied to the high precision bearings ranked higher than class 5, used with machined cage or molded cage.

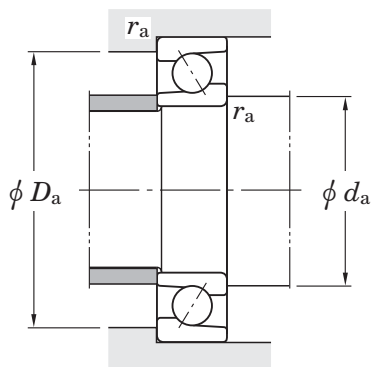

Bearing No. ²⁾	Load center (mm) <i>a</i>	Mounting dimensions (mm)			(Refer.) Mass (kg)
		<i>d_a</i> min.	<i>D_a</i> max.	<i>r_a</i> max.	
7211C	21.1	63.5	91.5	1.5	0.635
7311	40.2	65	110	2	1.45
7311B	51.8	65	110	2	1.45
7311C	26.4	65	110	2	1.45
7411	45.0	67	128	2	2.36
7411B	57.8	67	128	2	2.36
7912C	16.3	65.5	79.5	1	0.187
HAR912C	16.2	65.5	79.5	1	0.202
HAR012C	19.4	67	88	1	0.433
7012	31.4	67	88	1	0.450
7012B	41.5	67	88	1	0.450
7012C	19.4	67	88	1	0.450
7212	36.1	68.5	101.5	1.5	0.820
7212B	47.5	68.5	101.5	1.5	0.820
7212C	22.7	68.5	101.5	1.5	0.820
7312	43.2	72	118	2	1.81
7312B	55.8	72	118	2	1.81
7312C	28.4	72	118	2	1.81
7412	48.5	72	138	2	2.85
7412B	62.6	72	138	2	2.85
7913C	16.9	70.5	84.5	1	0.205
HAR913C	16.9	70.5	84.5	1	0.212
HAR013C	20.1	72	93	1	0.462
7013	33.0	72	93	1	0.470
7013B	43.8	72	93	1	0.470
7013C	20.1	72	93	1	0.470
7213	38.2	73.5	111.5	1.5	1.02

2) B, C or no indication after the bearing number indicates nominal contact angle of 40°, 15° and 30° respectively.

[Remark] Standard cage types used for the above bearings are described earlier in this section.

Single-row angular contact ball bearings

d (65) ~ (75) mm

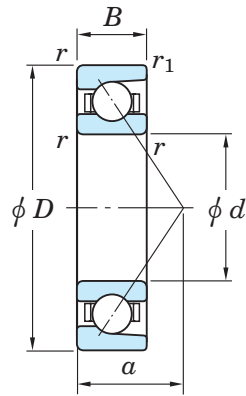

With machined cage

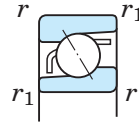

With pressed cage

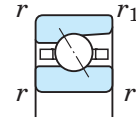

HAR

Boundary dimensions (mm)					Basic load ratings (kN)				Factor	Limiting speeds ¹⁾ (min ⁻¹)	
d	D	B	$r_{\min.}$	$r_{1\min.}$	With machined cage		With pressed cage			f_0	Grease lub.
					C_r	C_{0r}	C_r	C_{0r}			
65	120	23	1.5	1	60.9	49.3	63.6	52.6	—	4 800	6 400
	120	23	1.5	1	73.1	58.7	76.3	62.6	14.6	8 900	12 000
	140	33	2.1	1.1	105	75.3	111	82.2	—	5 800	7 200
	140	33	2.1	1.1	96.1	69.3	102	75.6	—	4 300	5 800
	140	33	2.1	1.1	112	80.7	119	88.1	13.4	8 000	11 000
	160	37	2.1	1.1	139	104	—	—	—	3 900	5 200
	160	37	2.1	1.1	129	96.8	—	—	—	3 500	4 800
70	100	16	1	0.6	28.9	29.0	—	—	16.4	10 000	12 000
	100	16	1	0.6	12.9	10.5	—	—	8.7	13 000	20 000
	110	20	1.1	0.6	20.7	15.5	—	—	8.4	12 000	19 000
	110	20	1.1	0.6	42.7	39.4	—	—	—	6 600	8 300
	110	20	1.1	0.6	38.3	35.5	—	—	—	5 000	6 600
	110	20	1.1	0.6	46.9	43.0	—	—	15.7	9 200	12 000
	125	24	1.5	1	69.8	55.6	76.3	63.5	—	6 100	7 600
	125	24	1.5	1	63.2	50.6	69.1	57.8	—	4 600	6 100
	125	24	1.5	1	75.9	60.2	83.0	68.8	14.6	8 400	11 000
	150	35	2.1	1.1	118	85.8	125	93.6	—	5 400	6 700
	150	35	2.1	1.1	108	78.9	114	86.0	—	4 000	5 400
	150	35	2.1	1.1	126	91.9	134	100	13.4	7 500	9 900
	180	42	3	1.1	149	115	—	—	—	3 500	4 600
180	42	3	1.1	148	119	—	—	—	3 100	4 300	
75	105	16	1	0.6	29.4	30.5	—	—	16.5	9 300	12 000
	105	16	1	0.6	13.3	11.2	—	—	8.7	12 000	19 000
	115	20	1.1	0.6	21.1	16.2	—	—	8.5	12 000	18 000
	115	20	1.1	0.6	43.6	41.7	—	—	—	6 300	7 800
	115	20	1.1	0.6	39.1	37.6	—	—	—	4 700	6 300
	115	20	1.1	0.6	48.0	45.6	—	—	15.9	8 700	11 000

[Notes] 1) Limiting speeds shown above are applicable to machined cage bearings.
 Limiting speeds of pressed cage bearings should be kept to under 80% of this value.
 For bearings with 15° contact angle, this figure is applied to the high precision bearings ranked higher than class 5, used with machined cage or molded cage.

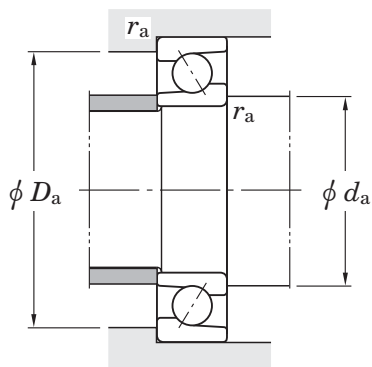

Bearing No. ²⁾	Load center (mm) <i>a</i>	Mounting dimensions (mm)			(Refer.) Mass (kg)
		<i>d_a</i> min.	<i>D_a</i> max.	<i>r_a</i> max.	
7213B	50.3	73.5	111.5	1.5	1.02
7213C	23.9	73.5	111.5	1.5	1.02
7313	46.3	77	128	2	2.22
7313B	59.7	77	128	2	2.22
7313C	30.3	77	128	2	2.22
7413	51.4	77	148	2	3.41
7413B	66.3	77	148	2	3.41
7914C	19.4	75.5	94.5	1	0.332
HAR914C	19.4	75.5	94.5	1	0.356
HAR014C	22.1	77	103	1	0.629
7014	36.0	77	103	1	0.660
7014B	47.8	77	103	1	0.660
7014C	22.1	77	103	1	0.660
7214	40.2	78.5	116.5	1.5	1.12
7214B	52.9	78.5	116.5	1.5	1.12
7214C	25.1	78.5	116.5	1.5	1.12
7314	49.3	82	138	2	2.70
7314B	63.7	82	138	2	2.70
7314C	32.2	82	138	2	2.70
7414	57.6	84	166	2.5	4.99
7414B	74.2	84	166	2.5	4.99
7915C	20.1	80.5	99.5	1	0.350
HAR915C	20.1	80.5	99.5	1	0.370
HAR015C	22.7	82	108	1	0.665
7015	37.4	82	108	1	0.690
7015B	49.9	82	108	1	0.690
7015C	22.7	82	108	1	0.690

2) B, C or no indication after the bearing number indicates nominal contact angle of 40°, 15° and 30° respectively.

[Remark] Standard cage types used for the above bearings are described earlier in this section.

Single-row angular contact ball bearings

d (75) ~ (85) mm

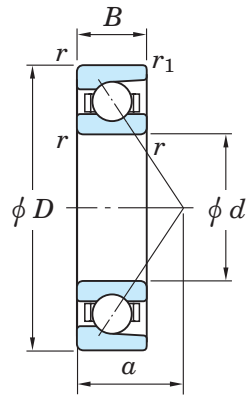

With machined cage

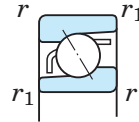

With pressed cage

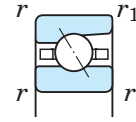

HAR

Boundary dimensions (mm)					Basic load ratings (kN)				Factor	Limiting speeds ¹⁾ (min ⁻¹)	
d	D	B	$r_{\min.}$	$r_{1\min.}$	With machined cage		With pressed cage			f_0	Grease lub.
					C_r	C_{0r}	C_r	C_{0r}			
75	130	25	1.5	1	79.2	65.2	82.7	69.5	—	5 800	7 200
	130	25	1.5	1	71.7	59.3	74.9	63.3	—	4 300	5 800
	130	25	1.5	1	86.1	70.6	89.9	75.3	14.6	8 000	11 000
	160	37	2.1	1.1	128	97.0	136	106	—	5 000	6 300
	160	37	2.1	1.1	118	89.2	125	97.3	—	3 800	5 000
	160	37	2.1	1.1	137	104	146	113	13.4	7 000	9 200
	190	45	3	1.1	171	141	—	—	—	3 300	4 400
	190	45	3	1.1	158	131	—	—	—	2 900	4 000
80	110	16	1	0.6	29.8	31.6	—	—	16.5	8 800	11 000
	110	16	1	0.6	13.6	11.9	—	—	8.8	12 000	18 000
	125	22	1.1	0.6	24.7	19.2	—	—	8.4	10 000	16 000
	125	22	1.1	0.6	53.4	50.6	—	—	—	5 800	7 200
	125	22	1.1	0.6	47.8	45.7	—	—	—	4 300	5 800
	125	22	1.1	0.6	58.7	55.3	—	—	15.7	8 000	11 000
	140	26	2	1	85.3	71.5	89.0	76.2	—	5 400	6 700
	140	26	2	1	77.1	65.0	80.5	69.3	—	4 000	5 400
	140	26	2	1	92.8	77.5	96.9	82.7	14.7	7 500	9 900
	170	39	2.1	1.1	139	109	147	119	—	4 700	5 900
	170	39	2.1	1.1	127	100	135	109	—	3 500	4 700
	170	39	2.1	1.1	149	117	158	127	13.5	6 500	8 600
	200	48	3	1.1	193	166	—	—	—	3 100	4 100
	200	48	3	1.1	179	154	—	—	—	2 700	3 800
85	120	18	1.1	0.6	38.9	40.6	—	—	16.5	8 100	11 000
	120	18	1.1	0.6	16.3	14.2	—	—	8.7	10 000	16 000
	130	22	1.1	0.6	25.1	20.1	—	—	8.5	9 700	15 000
	130	22	1.1	0.6	54.6	53.7	—	—	—	5 500	6 800
	130	22	1.1	0.6	48.8	48.4	—	—	—	4 100	5 500

[Notes] 1) Limiting speeds shown above are applicable to machined cage bearings.
 Limiting speeds of pressed cage bearings should be kept to under 80% of this value.
 For bearings with 15° contact angle, this figure is applied to the high precision bearings ranked higher than class 5, used with machined cage or molded cage.

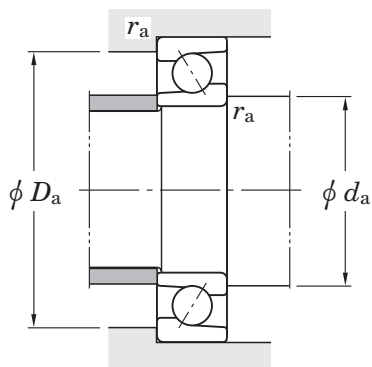

Bearing No. ²⁾	Load center (mm) <i>a</i>	Mounting dimensions (mm)			(Refer.) Mass (kg)
		<i>d_a</i> min.	<i>D_a</i> max.	<i>r_a</i> max.	
7215	42.1	83.5	121.5	1.5	1.23
7215B	55.5	83.5	121.5	1.5	1.23
7215C	26.2	83.5	121.5	1.5	1.23
7315	52.4	87	148	2	3.15
7315B	67.8	87	148	2	3.15
7315C	34.2	87	148	2	3.15
7415	61.3	89	176	2.5	5.90
7415B	78.9	89	176	2.5	5.90
7916C	20.7	85.5	104.5	1	0.368
HAR916C	20.7	85.5	104.5	1	0.398
HAR016C	24.7	87	118	1	0.903
7016	40.6	87	118	1	0.930
7016B	54.0	87	118	1	0.930
7016C	24.7	87	118	1	0.930
7216	44.8	90	130	2	1.50
7216B	59.2	90	130	2	1.50
7216C	27.7	90	130	2	1.50
7316	55.6	92	158	2	3.85
7316B	71.9	92	158	2	3.85
7316C	36.2	92	158	2	3.85
7416	65.0	94	186	2.5	6.00
7416B	83.6	94	186	2.5	6.00
7917C	22.7	92	113	1	0.523
HAR917C	22.7	92	113	1	0.570
HAR017C	25.4	92	123	1	0.947
7017	42.3	92	123	1	0.970
7017B	56.5	92	123	1	0.970

2) B, C or no indication after the bearing number indicates nominal contact angle of 40°, 15° and 30° respectively.

[Remark] Standard cage types used for the above bearings are described earlier in this section.

Single-row angular contact ball bearings

d (85) ~ (95) mm

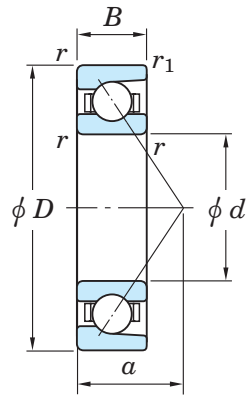

With machined cage

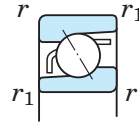

With pressed cage

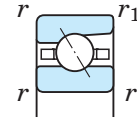

HAR

Boundary dimensions (mm)					Basic load ratings (kN)				Factor	Limiting speeds ¹⁾ (min ⁻¹)	
d	D	B	$r_{\min.}$	$r_{1\min.}$	With machined cage		With pressed cage			f_0	Grease lub.
					C_r	C_{0r}	C_r	C_{0r}			
85	130	22	1.1	0.6	60.1	58.7	—	—	15.9	7 600	10 000
	150	28	2	1	98.6	83.6	103	89.2	—	5 000	6 300
	150	28	2	1	89.2	76.0	93.1	81.1	—	3 800	5 000
	150	28	2	1	107	90.6	112	96.6	14.7	7 000	9 200
	180	41	3	1.1	150	122	159	133	—	4 400	5 500
	180	41	3	1.1	137	112	145	122	—	3 300	4 400
	180	41	3	1.1	161	130	170	142	13.5	6 100	8 100
	210	52	4	1.5	204	180	—	—	—	3 000	3 900
	210	52	4	1.5	189	167	—	—	—	2 600	3 600
90	125	18	1.1	0.6	39.6	42.6	—	—	16.6	7 800	10 000
	125	18	1.1	0.6	16.8	15.1	—	—	8.8	9 700	15 000
	140	24	1.5	1	32.8	26.1	—	—	8.4	9 100	14 000
	140	24	1.5	1	65.2	63.3	—	—	—	5 100	6 400
	140	24	1.5	1	58.4	57.1	—	—	—	3 900	5 100
	140	24	1.5	1	71.7	69.1	—	—	15.7	7 100	9 400
	160	30	2	1	113	96.7	118	103	—	4 700	5 900
	160	30	2	1	102	88.0	107	93.8	—	3 500	4 700
	160	30	2	1	123	105	128	112	14.6	6 500	8 600
	190	43	3	1.1	161	135	171	147	—	4 200	5 200
	190	43	3	1.1	148	124	156	135	—	3 100	4 200
	190	43	3	1.1	173	145	183	158	13.5	5 800	7 700
	225	54	4	1.5	216	196	—	—	—	2 800	3 700
	225	54	4	1.5	200	182	—	—	—	2 500	3 400
95	130	18	1.1	0.6	40.2	44.1	—	—	16.5	7 400	9 800
	130	18	1.1	0.6	17.3	16.0	—	—	8.8	9 300	14 000
	145	24	1.5	1	33.4	27.2	—	—	8.5	8 700	13 000
	145	24	1.5	1	66.6	67.1	—	—	—	4 800	6 000

[Notes] 1) Limiting speeds shown above are applicable to machined cage bearings.
 Limiting speeds of pressed cage bearings should be kept to under 80% of this value.
 For bearings with 15° contact angle, this figure is applied to the high precision bearings ranked higher than class 5, used with machined cage or molded cage.

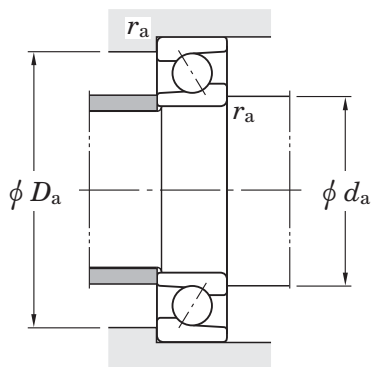

Bearing No. ²⁾	Load center (mm) <i>a</i>	Mounting dimensions (mm)			(Refer.) Mass (kg)
		<i>d_a</i> min.	<i>D_a</i> max.	<i>r_a</i> max.	
7017C	25.5	92	123	1	0.970
7217	47.9	95	140	2	1.87
7217B	63.3	95	140	2	1.87
7217C	29.7	95	140	2	1.87
7317	58.8	99	166	2.5	4.53
7317B	76.1	99	166	2.5	4.53
7317C	38.3	99	166	2.5	4.53
7417	68.7	103	192	3	8.54
7417B	88.1	103	192	3	8.54
7918C	23.4	97	118	1	0.551
HAR918C	23.4	97	118	1	0.598
HAR018C	27.4	98.5	131.5	1.5	1.21
7018	45.2	98.5	131.5	1.5	1.26
7018B	60.2	98.5	131.5	1.5	1.26
7018C	27.4	98.5	131.5	1.5	1.26
7218	51.1	100	150	2	2.30
7218B	67.4	100	150	2	2.30
7218C	31.7	100	150	2	2.30
7318	61.9	104	176	2.5	5.30
7318B	80.2	104	176	2.5	5.30
7318C	40.3	104	176	2.5	5.30
7418	72.5	108	207	3	11.4
7418B	93.1	108	207	3	11.4
7919C	24.1	102	123	1	0.574
HAR919C	24.1	102	123	1	0.626
HAR019C	28.1	103.5	136.5	1.5	1.28
7019	47.2	103.5	136.5	1.5	1.32

2) B, C or no indication after the bearing number indicates nominal contact angle of 40°, 15° and 30° respectively.

[Remark] Standard cage types used for the above bearings are described earlier in this section.

Single-row angular contact ball bearings

d (95) ~ (105) mm

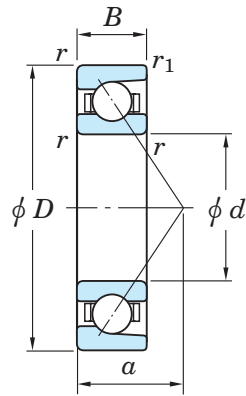

With machined cage

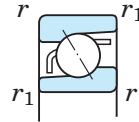

With pressed cage

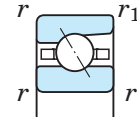

HAR

Boundary dimensions (mm)					Basic load ratings (kN)				Factor	Limiting speeds ¹⁾ (min ⁻¹)	
d	D	B	$r_{\min.}$	$r_{1\min.}$	With machined cage		With pressed cage			f_0	Grease lub.
					C_r	C_{0r}	C_r	C_{0r}			
95	145	24	1.5	1	59.6	60.5	—	—	—	3 600	4 800
	145	24	1.5	1	73.4	73.4	—	—	15.9	6 700	8 900
	170	32	2.1	1.1	122	103	128	111	—	4 400	5 500
	170	32	2.1	1.1	111	94.0	116	101	—	3 300	4 400
	170	32	2.1	1.1	133	112	139	120	14.6	6 100	8 100
	200	45	3	1.1	172	149	183	162	—	4 000	4 900
	200	45	3	1.1	158	137	167	149	—	3 000	4 000
	200	45	3	1.1	185	160	196	174	13.5	5 500	7 300
100	140	20	1.1	0.6	55.6	58.5	—	—	16.3	7 000	9 200
	140	20	1.1	0.6	24.2	21.7	—	—	8.7	8 700	13 000
	150	24	1.5	1	34.0	28.4	—	—	8.5	8 400	13 000
	150	24	1.5	1	68.4	70.6	—	—	—	4 700	5 900
	150	24	1.5	1	61.2	63.6	—	—	—	3 500	4 700
	150	24	1.5	1	75.3	77.2	—	—	16.0	6 500	8 600
	180	34	2.1	1.1	137	117	144	126	—	4 100	5 200
	180	34	2.1	1.1	124	107	130	115	—	3 100	4 200
	180	34	2.1	1.1	149	127	156	136	14.6	5 700	7 600
	215	47	3	1.1	184	161	207	194	—	3 600	4 600
	215	47	3	1.1	168	148	190	178	—	2 700	3 600
	215	47	3	1.1	197	173	222	208	13.4	5 000	6 700
105	145	20	1.1	0.6	56.7	61.5	—	—	16.4	6 700	8 800
	145	20	1.1	0.6	24.9	23.1	—	—	8.7	8 400	13 000
	160	26	2	1	38.6	32.5	—	—	8.5	7 900	12 000
	160	26	2	1	79.8	81.9	—	—	—	4 400	5 500
	160	26	2	1	71.4	73.8	—	—	—	3 300	4 400
	160	26	2	1	87.8	89.6	—	—	15.9	6 000	8 000
	190	36	2.1	1.1	149	132	—	—	—	3 900	4 900

[Notes] 1) Limiting speeds shown above are applicable to machined cage bearings. Limiting speeds of pressed cage bearings should be kept to under 80% of this value. For bearings with 15° contact angle, this figure is applied to the high precision bearings ranked higher than class 5, used with machined cage or molded cage.

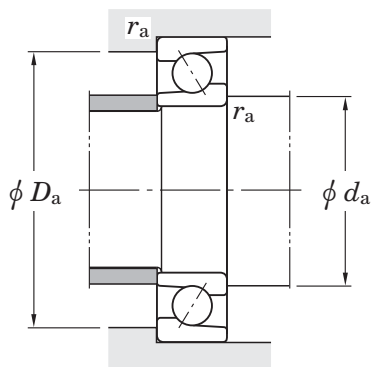

Bearing No. ²⁾	Load center (mm) <i>a</i>	Mounting dimensions (mm)			(Refer.) Mass (kg)
		<i>d_a</i> min.	<i>D_a</i> max.	<i>r_a</i> max.	
7019B	63.2	103.5	136.5	1.5	1.32
7019C	28.3	103.5	136.5	1.5	1.32
7219	54.3	107	158	2	2.78
7219B	71.6	107	158	2	2.78
7219C	33.8	107	158	2	2.78
7319	65.1	109	186	2.5	6.12
7319B	84.4	109	186	2.5	6.12
7319C	42.3	109	186	2.5	6.12
7920C	26.1	107	133	1	0.773
HAR920C	26.1	107	133	1	0.839
HAR020C	28.7	108.5	141.5	1.5	1.32
7020	48.1	108.5	141.5	1.5	1.37
7020B	64.4	108.5	141.5	1.5	1.37
7020C	28.7	108.5	141.5	1.5	1.37
7220	57.7	112	168	2	3.32
7220B	76.2	112	168	2	3.32
7220C	35.9	112	168	2	3.32
7320	69.4	114	201	2.5	7.53
7320B	90.2	114	201	2.5	7.53
7320C	44.8	114	201	2.5	7.53
7921C	26.7	112	138	1	0.810
HAR921C	26.7	112	138	1	0.874
HAR021C	30.8	115	150	2	1.68
7021	51.8	115	150	2	1.73
7021B	68.6	115	150	2	1.73
7021C	31.0	115	150	2	1.73
7221	61.0	117	178	2	3.95

2) B, C or no indication after the bearing number indicates nominal contact angle of 40°, 15° and 30° respectively.

[Remark] Standard cage types used for the above bearings are described earlier in this section.

Single-row angular contact ball bearings

d (105) ~ (120) mm

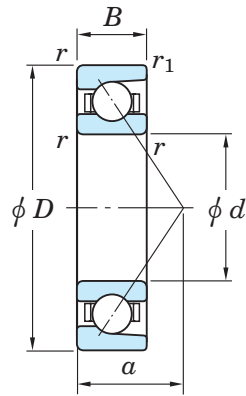

With machined cage

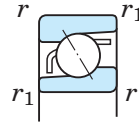

With pressed cage

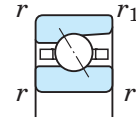

HAR

Boundary dimensions (mm)					Basic load ratings (kN)				Factor f_0	Limiting speeds ¹⁾ (min ⁻¹)	
d	D	B	$r_{\min.}$	$r_{1\min.}$	With machined cage		With pressed cage			Grease lub.	Oil lub.
					C_r	C_{0r}	C_r	C_{0r}			
105	190	36	2.1	1.1	135	121	—	—	—	2 900	3 900
	190	36	2.1	1.1	162	143	—	—	14.6	5 400	7 200
	225	49	3	1.1	208	193	—	—	—	3 500	4 400
	225	49	3	1.1	191	177	—	—	—	2 600	3 500
	225	49	3	1.1	223	207	—	—	13.4	4 800	6 400
110	150	20	1.1	0.6	57.7	64.4	—	—	16.5	6 400	8 500
	150	20	1.1	0.6	25.1	23.8	—	—	8.7	8 000	12 000
	170	28	2	1	43.4	37.0	—	—	8.5	7 500	12 000
	170	28	2	1	91.9	92.8	—	—	—	4 200	5 200
	170	28	2	1	82.3	83.7	—	—	—	3 100	4 200
	170	28	2	1	101	101	—	—	15.7	5 800	7 700
	200	38	2.1	1.1	162	148	—	—	—	3 700	4 600
	200	38	2.1	1.1	147	135	—	—	—	2 800	3 700
	200	38	2.1	1.1	176	160	—	—	14.5	5 100	6 800
	240	50	3	1.1	232	226	—	—	—	3 200	4 000
	240	50	3	1.1	213	208	—	—	—	2 400	3 200
	240	50	3	1.1	249	242	—	—	13.4	4 500	5 900
120	165	22	1.1	0.6	71.7	81.2	—	—	16.5	5 900	7 800
	165	22	1.1	0.6	29.4	28.4	—	—	8.8	7 300	11 000
	180	28	2	1	44.9	39.9	—	—	8.5	7 000	11 000
	180	28	2	1	96.6	103	—	—	—	3 900	4 900
	180	28	2	1	86.4	93.0	—	—	—	2 900	3 900
	180	28	2	1	106	113	—	—	16.0	5 400	7 100
	215	40	2.1	1.1	174	166	—	—	—	3 400	4 300
	215	40	2.1	1.1	158	151	—	—	—	2 600	3 400
	215	40	2.1	1.1	190	180	—	—	14.6	4 800	6 300
	260	55	3	1.1	246	252	—	—	—	3 000	3 700

[Notes] 1) Limiting speeds shown above are applicable to machined cage bearings.
 Limiting speeds of pressed cage bearings should be kept to under 80% of this value.
 For bearings with 15° contact angle, this figure is applied to the high precision bearings ranked higher than class 5, used with machined cage or molded cage.

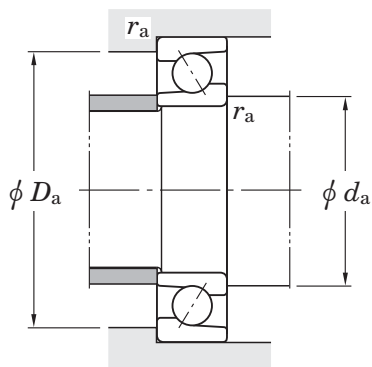

Bearing No. ²⁾	Load center (mm) <i>a</i>	Mounting dimensions (mm)			(Refer.) Mass (kg)
		<i>d</i> _a min.	<i>D</i> _a max.	<i>r</i> _a max.	
7221B	80.5	117	178	2	3.95
7221C	38.0	117	178	2	3.95
7321	72.1	119	211	2.5	8.62
7321B	93.7	119	211	2.5	8.62
7321C	46.6	119	211	2.5	8.62
7922C	27.4	117	143	1	0.840
HAR922C	27.4	117	143	1	0.909
HAR022C	32.8	120	160	2	2.11
7022	54.4	120	160	2	2.14
7022B	72.7	120	160	2	2.14
7022C	32.8	120	160	2	2.14
7222	64.3	122	188	2	4.65
7222B	84.9	122	188	2	4.65
7222C	40.0	122	188	2	4.65
7322	76.4	124	226	2.5	10.1
7322B	99.6	124	226	2.5	10.1
7322C	48.8	124	226	2.5	10.1
7924C	30.1	127	158	1	1.15
HAR924C	30.1	127	158	1	1.25
HAR024C	34.1	130	170	2	2.26
7024	57.3	130	170	2	2.27
7024B	76.9	130	170	2	2.27
7024C	34.1	130	170	2	2.27
7224	68.5	132	203	2	5.49
7224B	90.3	132	203	2	5.49
7224C	42.5	132	203	2	5.49
7324	82.3	134	246	2.5	12.6

2) B, C or no indication after the bearing number indicates nominal contact angle of 40°, 15° and 30° respectively.

[Remark] Standard cage types used for the above bearings are described earlier in this section.

Single-row angular contact ball bearings

d (120) ~ 140 mm

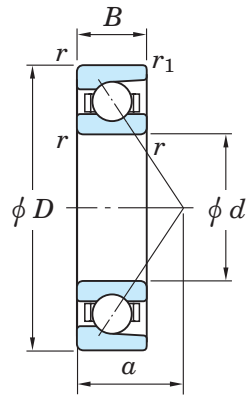

With machined cage

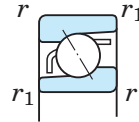

With pressed cage

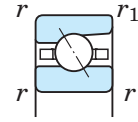

HAR

Boundary dimensions (mm)					Basic load ratings (kN)				Factor	Limiting speeds ¹⁾ (min ⁻¹)	
d	D	B	$r_{\min.}$	$r_{1\min.}$	With machined cage		With pressed cage			f_0	Grease lub.
					C_r	C_{0r}	C_r	C_{0r}			
120	260	55	3	1.1	225	231	—	—	—	2 200	3 000
	260	55	3	1.1	265	271	—	—	13.7	4 100	5 500
130	180	24	1.5	1	87.2	99.9	—	—	16.4	5 400	7 100
	180	24	1.5	1	35.1	35.1	—	—	8.8	6 700	10 000
	200	33	2	1	56.3	48.4	—	—	8.5	6 300	9 800
	200	33	2	1	117	125	—	—	—	3 500	4 400
	200	33	2	1	105	113	—	—	—	2 600	3 500
	200	33	2	1	129	137	—	—	15.9	4 800	6 400
	230	40	3	1.1	196	198	—	—	—	3 200	4 000
	230	40	3	1.1	177	180	—	—	—	2 400	3 200
	230	40	3	1.1	213	214	—	—	14.7	4 400	5 800
	280	58	4	1.5	301	329	—	—	—	2 700	3 400
	280	58	4	1.5	250	268	—	—	—	2 100	2 700
	280	58	4	1.5	294	314	—	—	13.7	3 800	5 000
	140	190	24	1.5	1	88.3	105	—	—	16.6	5 100
190		24	1.5	1	35.2	36.2	—	—	8.8	6 300	9 800
210		33	2	1	61.3	56.2	—	—	8.5	6 000	9 200
210		33	2	1	120	133	—	—	—	3 300	4 100
210		33	2	1	107	119	—	—	—	2 500	3 300
210		33	2	1	132	145	—	—	16.0	4 500	6 000
250		42	3	1.1	218	234	—	—	—	2 900	3 600
250		42	3	1.1	197	213	—	—	—	2 200	2 900
250		42	3	1.1	238	254	—	—	14.8	4 000	5 300
300		62	4	1.5	329	374	—	—	—	2 500	3 200
300		62	4	1.5	302	344	—	—	—	1 900	2 500
300		62	4	1.5	353	401	—	—	13.4	3 500	4 600

[Notes] 1) Limiting speeds shown above are applicable to machined cage bearings. Limiting speeds of pressed cage bearings should be kept to under 80% of this value. For bearings with 15° contact angle, this figure is applied to the high precision bearings ranked higher than class 5, used with machined cage or molded cage.

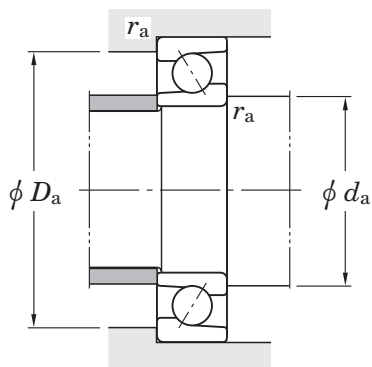

Bearing No. ²⁾	Load center (mm) <i>a</i>	Mounting dimensions (mm)			(Refer.) Mass (kg)
		<i>d_a</i> min.	<i>D_a</i> max.	<i>r_a</i> max.	
7324B	107.2	134	246	2.5	12.6
7324C	53.0	134	246	2.5	12.6
7926C	32.8	138.5	171.5	1.5	1.50
HAR926C	32.8	138.5	171.5	1.5	1.66
HAR026C	38.6	140	190	2	3.38
7026	64.1	140	190	2	3.43
7026B	85.7	140	190	2	3.43
7026C	38.6	140	190	2	3.43
7226	72.0	144	216	2.5	6.21
7226B	95.5	144	216	2.5	6.21
7226C	44.1	144	216	2.5	6.21
7326	88.8	148	262	3	15.4
7326B	115.0	148	262	3	15.4
7326C	56.5	148	262	3	15.4
7928C	34.1	148.5	181.5	1.5	1.59
HAR928C	34.1	148.5	181.5	1.5	1.76
HAR028C	39.9	150	200	2	3.62
7028	67.0	150	200	2	3.64
7028B	89.9	150	200	2	3.64
7028C	39.9	150	200	2	3.64
7228	77.3	154	236	2.5	7.76
7228B	102.8	154	236	2.5	7.76
7228C	47.1	154	236	2.5	7.76
7328	94.5	158	282	3	18.8
7328B	123.3	158	282	3	18.8
7328C	60.5	158	282	3	18.8

2) B, C or no indication after the bearing number indicates nominal contact angle of 40°, 15° and 30° respectively.

[Remark] Standard cage types used for the above bearings are described earlier in this section.

Single-row angular contact ball bearings

d 150 ~ (170) mm

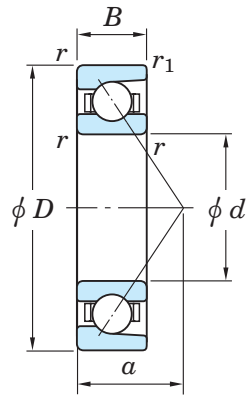

With machined cage

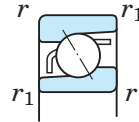

With pressed cage

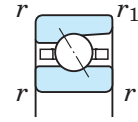

HAR

Boundary dimensions (mm)					Basic load ratings (kN)				Factor	Limiting speeds ¹⁾ (min ⁻¹)	
d	D	B	$r_{\min.}$	$r_{1\min.}$	With machined cage		With pressed cage			Grease lub.	Oil lub.
					C_r	C_{0r}	C_r	C_{0r}	f_0		
150	210	28	2	1	115	132	—	—	16.3	4 700	6 200
	210	28	2	1	48.9	48.9	—	—	8.7	5 800	9 000
	225	35	2	1	72.2	66.1	—	—	8.5	5 300	8 200
	225	35	2.1	1.1	137	154	—	—	—	3 000	3 800
	225	35	2.1	1.1	122	138	—	—	—	2 300	3 000
	225	35	2.1	1.1	151	169	—	—	16.1	4 200	5 500
	270	45	3	1.1	248	280	—	—	—	2 700	3 300
	270	45	3	1.1	225	254	—	—	—	2 000	2 700
	270	45	3	1.1	270	303	—	—	14.7	3 700	4 900
	320	65	4	1.5	348	414	—	—	—	2 300	2 900
	320	65	4	1.5	318	380	—	—	—	1 800	2 300
	320	65	4	1.5	374	445	—	—	13.7	3 200	4 300
160	220	28	2	1	120	144	—	—	16.5	4 400	5 800
	220	28	2	1	50.2	51.8	—	—	8.8	5 200	8 100
	240	38	2.1	1.1	78.3	72.7	—	—	8.5	5 000	7 700
	240	38	2.1	1.1	155	176	—	—	—	2 800	3 500
	240	38	2.1	1.1	139	158	—	—	—	2 100	2 800
	240	38	2.1	1.1	171	193	—	—	16.0	3 900	5 200
	290	48	3	1.1	230	263	—	—	—	2 500	3 100
	290	48	3	1.1	238	279	—	—	—	1 800	2 500
	290	48	3	1.1	287	333	—	—	15.2	3 400	4 500
	340	68	4	1.5	365	455	—	—	—	2 200	2 700
	340	68	4	1.5	332	416	—	—	—	1 600	2 200
	340	68	4	1.5	394	490	—	—	14.0	3 000	4 000
170	230	28	2	1	122	151	—	—	16.6	3 900	5 100
	230	28	2	1	51.4	54.8	—	—	8.8	5 000	7 700
	260	42	2.1	1.1	91.8	86.4	—	—	8.5	4 600	7 100

[Notes] 1) Limiting speeds shown above are applicable to machined cage bearings. Limiting speeds of pressed cage bearings should be kept to under 80% of this value. For bearings with 15° contact angle, this figure is applied to the high precision bearings ranked higher than class 5, used with machined cage or molded cage.

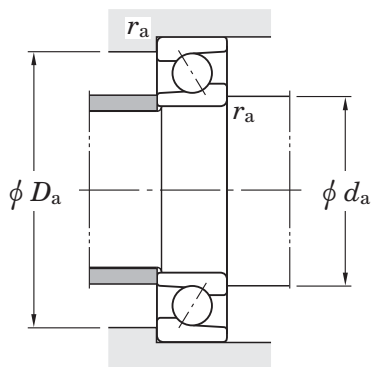

Bearing No. ²⁾	Load center (mm) <i>a</i>	Mounting dimensions (mm)			(Refer.) Mass (kg)
		<i>d_a</i> min.	<i>D_a</i> max.	<i>r_a</i> max.	
7930C	38.1	160	200	2	2.47
HAR930C	38.1	160	200	2	2.68
HAR030C	42.6	160	215	2	4.36
7030	72.1	162	213	2	4.43
7030B	96.2	162	213	2	4.43
7030C	42.8	162	213	2	4.43
7230	83.1	164	256	2.5	9.75
7230B	110.6	164	256	2.5	9.75
7230C	50.6	164	256	2.5	9.75
7330	100.3	168	302	3	22.4
7330B	131.1	168	302	3	22.4
7330C	64.0	168	302	3	22.4
7932C	39.5	170	210	2	2.60
HAR932C	39.5	170	210	2	2.83
HAR032C	45.8	172	228	2	5.40
7032	76.8	172	228	2	5.45
7032B	102.9	172	228	2	5.45
7032C	45.8	172	228	2	5.45
7232	89.0	174	276	2.5	12.1
7232B	118.4	174	276	2.5	12.1
7232C	54.1	174	276	2.5	12.1
7332	106.2	178	322	3	26.4
7332B	138.9	178	322	3	26.4
7332C	67.5	168.5	322	3	26.4
7934C	40.8	180	220	2	3.21
HAR934C	40.8	180	220	2	2.97
HAR034C	49.8	182	248	2	7.32

2) B, C or no indication after the bearing number indicates nominal contact angle of 40°, 15° and 30° respectively.

[Remark] Standard cage types used for the above bearings are described earlier in this section.

Single-row angular contact ball bearings

d (170) ~ 190 mm

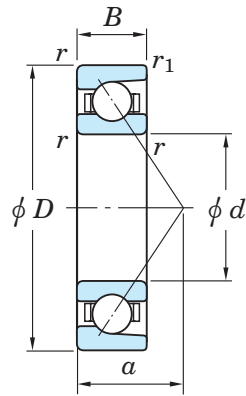

With machined cage

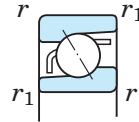

With pressed cage

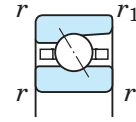

HAR

Boundary dimensions (mm)					Basic load ratings (kN)				Factor	Limiting speeds ¹⁾ (min ⁻¹)	
d	D	B	$r_{\min.}$	$r_{1\min.}$	With machined cage		With pressed cage			Grease lub.	Oil lub.
					C_r	C_{0r}	C_r	C_{0r}	f_0		
170	260	42	2.1	1.1	186	214	—	—	—	2 600	3 200
	260	42	2.1	1.1	166	193	—	—	—	1 900	2 600
	260	42	2.1	1.1	204	234	—	—	15.9	3 600	4 800
	310	52	4	1.5	272	331	—	—	—	2 300	2 800
	310	52	4	1.5	245	300	—	—	—	1 700	2 300
	310	52	4	1.5	297	359	—	—	15.1	3 100	4 200
	360	72	4	1.5	389	485	—	—	—	2 000	2 500
	360	72	4	1.5	355	444	—	—	—	1 500	2 000
	360	72	4	1.5	418	521	—	—	13.8	2 800	3 700
180	250	33	2	1	156	188	—	—	16.4	3 600	4 700
	280	46	2.1	1.1	212	253	—	—	—	2 400	3 000
	280	46	2.1	1.1	190	228	—	—	—	1 800	2 400
	280	46	2.1	1.1	233	276	—	—	15.7	3 300	4 400
	320	52	4	1.5	293	362	—	—	—	2 200	2 700
	320	52	4	1.5	265	329	—	—	—	1 600	2 200
	320	52	4	1.5	320	393	—	—	14.9	3 000	4 000
	380	75	4	1.5	409	534	—	—	—	1 900	2 400
	380	75	4	1.5	373	488	—	—	—	1 400	1 900
190	260	33	2	1	158	197	—	—	16.5	3 300	4 500
	290	46	2.1	1.1	217	268	—	—	—	2 300	2 800
	290	46	2.1	1.1	194	241	—	—	—	1 700	2 300
	290	46	2.1	1.1	239	293	—	—	15.9	3 100	4 200
	340	55	4	1.5	303	390	—	—	—	2 000	2 500
	340	55	4	1.5	273	353	—	—	—	1 500	2 000
	340	55	4	1.5	331	424	—	—	15.1	2 800	3 700
	400	78	5	2	450	598	—	—	—	1 800	2 200
	400	78	5	2	411	548	—	—	—	1 300	1 800

[Notes] 1) Limiting speeds shown above are applicable to machined cage bearings. Limiting speeds of pressed cage bearings should be kept to under 80% of this value. For bearings with 15° contact angle, this figure is applied to the high precision bearings ranked higher than class 5, used with machined cage or molded cage.

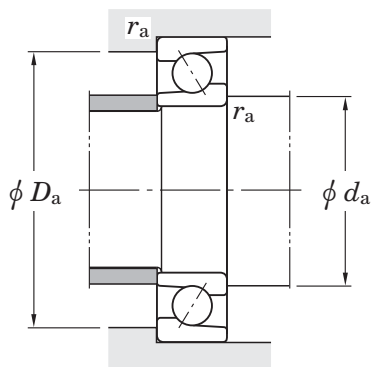

Bearing No. ²⁾	Load center (mm) <i>a</i>	Mounting dimensions (mm)			(Refer.) Mass (kg)
		<i>d_a</i> min.	<i>D_a</i> max.	<i>r_a</i> max.	
7034	83.1	182	248	2	7.58
7034B	111.2	182	248	2	7.77
7034C	49.8	182	248	2	7.57
7234	95.3	188	292	3	15.1
7234B	126.7	188	292	3	15.1
7234C	58.2	188	292	3	15.1
7334	112.5	188	342	3	31.2
7334B	147.2	188	342	3	31.2
7334C	71.5	188	342	3	31.2
7936C	45.3	190	240	2	4.68
7036	89.4	192	268	2	10.1
7036B	119.5	192	268	2	10.2
7036C	53.8	192	268	2	9.96
7236	98.2	198	302	3	15.7
7236B	130.9	198	302	3	15.7
7236C	59.5	198	302	3	15.7
7336	118.3	198	362	3	40.0
7336B	155.0	198	362	3	40.0
7938C	46.6	200	250	2	4.83
7038	92.3	202	278	2	10.8
7038B	123.7	202	278	2	10.8
7038C	55.2	202	278	2	10.8
7238	104.0	208	322	3	18.8
7238B	138.7	208	322	3	18.8
7238C	63.0	208	322	3	18.8
7338	124.2	212	378	4	45.5
7338B	162.8	212	378	4	45.5

2) B, C or no indication after the bearing number indicates nominal contact angle of 40°, 15° and 30° respectively.

[Remark] Standard cage types used for the above bearings are described earlier in this section.

Single-row angular contact ball bearings

d 200 ~ (340) mm

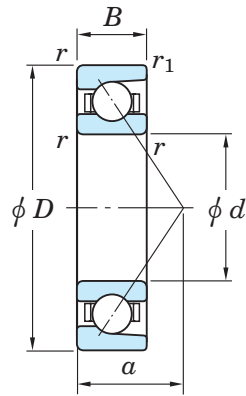

With machined cage

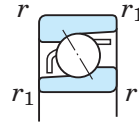

With pressed cage

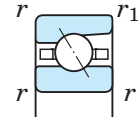

HAR

Boundary dimensions (mm)					Basic load ratings (kN)				Factor	Limiting speeds ¹⁾ (min ⁻¹)	
d	D	B	$r_{\min.}$	$r_{1\min.}$	With machined cage		With pressed cage			Grease lub.	Oil lub.
					C_r	C_{0r}	C_r	C_{0r}	f_0		
200	280	38	2.1	1.1	204	255	—	—	16.3	3 100	4 100
	310	51	2.1	1.1	244	309	—	—	—	2 100	2 600
	310	51	2.1	1.1	218	279	—	—	—	1 600	2 100
	310	51	2.1	1.1	268	338	—	—	15.7	2 900	3 900
	360	58	4	1.5	324	423	—	—	—	1 900	2 400
	360	58	4	1.5	292	384	—	—	—	1 400	1 900
	360	58	4	1.5	354	460	—	—	15.1	2 600	3 500
	420	80	5	2	474	658	—	—	—	1 700	2 100
	420	80	5	2	432	602	—	—	—	1 200	1 700
220	340	56	3	1.1	267	353	—	—	—	1 900	2 400
	340	56	3	1.1	239	318	—	—	—	1 400	1 900
240	360	56	3	1.1	273	375	—	—	—	1 700	2 200
	360	56	3	1.1	244	338	—	—	—	1 300	1 700
	440	72	4	1.5	403	595	—	—	—	1 500	1 800
	440	72	4	1.5	363	539	—	—	—	1 100	1 500
260	400	65	4	1.5	325	478	—	—	—	1 500	1 900
	400	65	4	1.5	291	431	—	—	—	1 100	1 500
280	420	65	4	1.5	332	507	—	—	—	1 400	1 800
	420	65	4	1.5	297	453	—	—	—	1 100	1 400
300	460	74	4	1.5	426	680	—	—	—	1 300	1 600
	460	74	4	1.5	382	613	—	—	—	960	1 300
320	480	74	4	1.5	437	722	—	—	—	1 200	1 500
	480	74	4	1.5	391	651	—	—	—	890	1 200
340	520	82	5	2	502	861	—	—	—	1 100	1 300

[Notes] 1) Limiting speeds shown above are applicable to machined cage bearings.
 Limiting speeds of pressed cage bearings should be kept to under 80% of this value.
 For bearings with 15° contact angle, this figure is applied to the high precision bearings ranked higher than class 5, used with machined cage or molded cage.

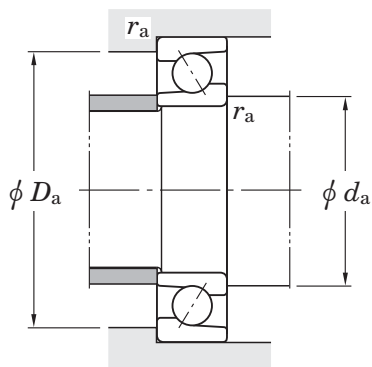

Bearing No. ²⁾	Load center (mm) <i>a</i>	Mounting dimensions (mm)			(Refer.) Mass (kg)
		<i>d_a</i> min.	<i>D_a</i> max.	<i>r_a</i> max.	
7940C	51.2	212	268	2	6.85
7040	99.1	212	298	2	12.7
7040B	132.5	212	298	2	12.7
7040C	59.7	212	298	2	12.7
7240	109.8	218	342	3	22.4
7240B	146.5	218	342	3	22.4
7240C	66.5	218	342	3	22.4
7340	129.5	222	398	4	52.0
7340B	170.1	222	398	4	52.0
7044	108.9	234	326	2.5	18.5
7044B	145.5	234	326	2.5	18.9
7048	114.6	254	346	2.5	19.7
7048B	153.9	254	346	2.5	20.1
7248	134.2	258	422	3	51.8
7248B	178.6	258	422	3	52.8
7052	128.4	278	382	3	28.7
7052B	171.0	278	382	3	29.3
7056	133.5	298	402	3	30.4
7056B	179.3	298	402	3	31.0
7060	146.7	318	442	3	43.7
7060B	196.4	318	442	3	44.9
7064	152.5	338	462	3	46.0
7064B	204.8	338	462	3	47.2
7068	165.1	362	498	4	61.8

2) B, C or no indication after the bearing number indicates nominal contact angle of 40°, 15° and 30° respectively.

[Remark] Standard cage types used for the above bearings are described earlier in this section.

Single-row angular contact ball bearings

d (340) ~ 380 mm

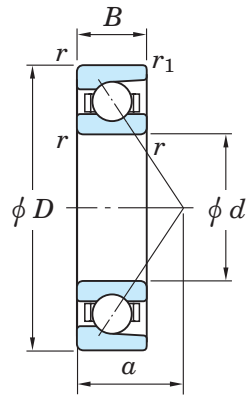

With machined cage

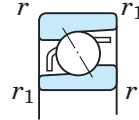

With pressed cage

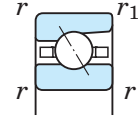

HAR

Boundary dimensions (mm)					Basic load ratings (kN)				Factor f_0	Limiting speeds ¹⁾ (min ⁻¹)	
d	D	B	$r_{\min.}$	$r_{1\min.}$	With machined cage		With pressed cage			Grease lub.	Oil lub.
					C_r	C_{0r}	C_r	C_{0r}			
340	520	82	5	2	450	777	—	—	—	800	1 100
360	540	82	5	2	515	913	—	—	—	1 000	1 300
	540	82	5	2	461	824	—	—	—	750	1 000
380	560	82	5	2	528	966	—	—	—	940	1 200
	560	82	5	2	472	870	—	—	—	700	940

[Notes] 1) Limiting speeds shown above are applicable to machined cage bearings.
 Limiting speeds of pressed cage bearings should be kept to under 80% of this value.
 For bearings with 15° contact angle, this figure is applied to the high precision bearings ranked higher than class 5, used with machined cage or molded cage.

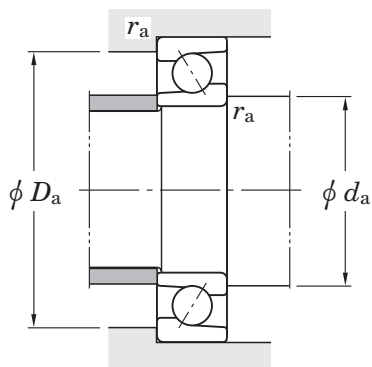

Bearing No. ²⁾	Load center (mm) <i>a</i>	Mounting dimensions (mm)			(Refer.) Mass (kg)
		<i>d_a</i> min.	<i>D_a</i> max.	<i>r_a</i> max.	
7068B	221.4	362	498	4	63.3
7072	170.9	382	518	4	64.6
7072B	229.8	382	518	4	66.2
7076	176.7	402	538	4	67.2
7076B	238.2	402	538	4	69.1

2) B or no indication after the bearing number indicates nominal contact angle of 15° and 30° respectively.

[Remark] Standard cage types used for the above bearings are described earlier in this section.

Angular contact ball bearings (matched pair)

d 10 ~ (17) mm

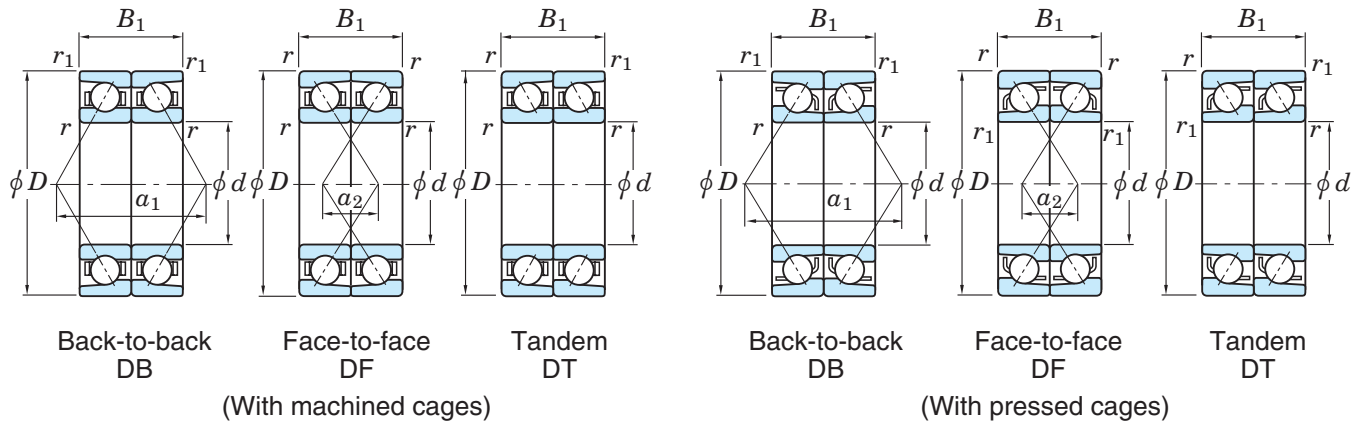

Boundary dimensions (mm)					Basic load ratings (kN)				Factor	Limiting speeds ¹⁾ (min ⁻¹)		Back-to-back DB
d	D	B_1	$r_{\min.}$	$r_{1\min.}$	With machined cages		With pressed cages			Grease lub.	Oil lub.	
					C_r	C_{Or}	C_r	C_{Or}	f_0			
10	22	12	0.3	0.15	4.90	3.05	—	—	14.2	42 000	55 000	7900CDB
	26	16	0.3	0.15	8.10	4.65	—	—	—	27 000	34 000	7000DB
	26	16	0.3	0.15	7.55	4.35	—	—	—	20 000	27 000	7000BDB
	26	16	0.3	0.15	8.60	4.95	—	—	12.5	37 000	50 000	7000CDB
	30	18	0.6	0.3	7.55	4.40	8.80	5.45	—	23 000	29 000	7200DB
	30	18	0.6	0.3	6.95	4.05	8.10	5.05	—	18 000	23 000	7200BDB
	30	18	0.6	0.3	8.10	4.70	9.45	5.85	13.4	32 000	43 000	7200CDB
	35	22	0.6	0.3	13.8	7.55	15.1	8.60	—	21 000	27 000	7300DB
12	24	12	0.3	0.15	5.15	3.45	—	—	14.7	37 000	49 000	7901CDB
	28	16	0.3	0.15	8.80	5.45	—	—	—	23 000	29 000	7001DB
	28	16	0.3	0.15	8.10	5.05	—	—	—	18 000	23 000	7001BDB
	28	16	0.3	0.15	9.40	5.85	—	—	13.4	32 000	43 000	7001CDB
	32	20	0.6	0.3	12.1	7.25	13.0	8.05	—	22 000	27 000	7201DB
	32	20	0.6	0.3	11.3	6.80	12.1	7.50	—	16 000	22 000	7201BDB
	32	20	0.6	0.3	12.8	7.70	13.8	8.55	12.5	30 000	40 000	7201CDB
	37	24	1	0.6	16.6	9.20	18.1	10.5	—	20 000	24 000	7301DB
15	28	14	0.3	0.15	7.75	5.30	—	—	14.5	31 000	41 000	7902CDB
	32	18	0.3	0.15	9.95	6.85	—	—	—	20 000	26 000	7002DB
	32	18	0.3	0.15	9.05	6.30	—	—	—	15 000	20 000	7002BDB
	32	18	0.3	0.15	10.7	7.40	—	—	14.1	28 000	37 000	7002CDB
	35	22	0.6	0.3	13.2	8.55	13.2	8.55	—	19 000	24 000	7202DB
	35	22	0.6	0.3	12.1	7.85	12.1	7.85	—	14 000	19 000	7202BDB
	35	22	0.6	0.3	14.1	9.15	14.1	9.15	13.3	26 000	35 000	7202CDB
	42	26	1	0.6	20.3	12.9	21.8	14.4	—	16 000	20 000	7302DB
17	30	14	0.3	0.15	8.10	5.90	—	—	14.9	28 000	38 000	7903CDB
	35	20	0.3	0.15	10.9	8.25	—	—	—	18 000	23 000	7003DB

[Notes] 1) Limiting speeds shown above are applicable to machined cage bearings.
 Limiting speeds of pressed cage bearings should be kept to under 80% of this value.
 For bearings with 15° contact angle, this figure is applied to the high precision bearings ranked higher than class 5, used with machined cages or molded cages.

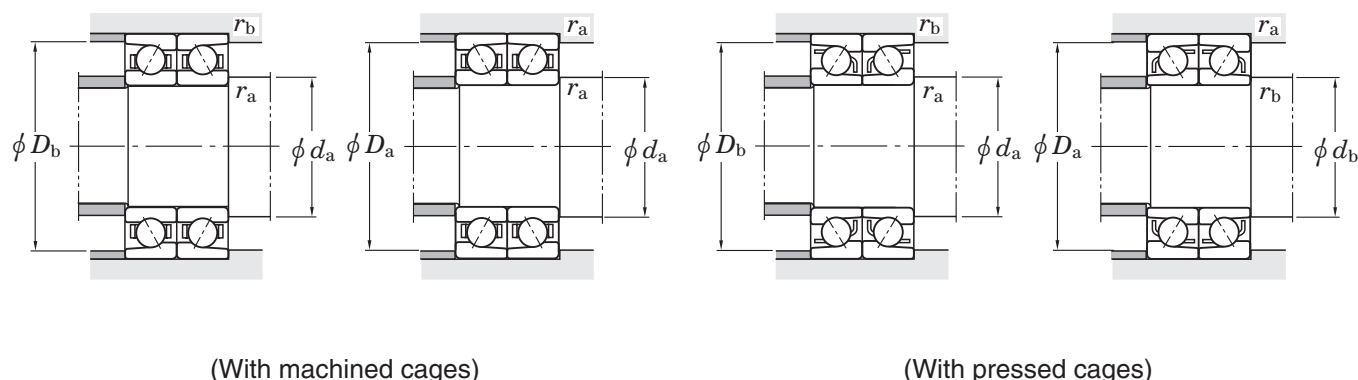

Bearing No. ²⁾		Load center spread (mm)		Mounting dimensions (mm)						(Refer.) Mass (kg)
				d_a min.	d_b min.	D_a max.	D_b max.	r_a max.	r_b max.	
Face-to-face DF	Tandem DT	a_1	a_2							
7900CDF	7900CDT	10.3	1.7	12.5	—	19.5	20.8	0.3	0.15	0.016
7000DF	7000DT	18.2	2.2	12.5	—	23.5	24.8	0.3	0.15	0.042
7000BDF	7000BDT	23.1	7.1	12.5	—	23.5	24.8	0.3	0.15	0.042
7000CDF	7000CDT	12.7	3.3	12.5	—	23.5	24.8	0.3	0.15	0.042
7200DF	7200DT	20.8	2.8	14.5	12.5	25.5	27.5	0.6	0.3	0.062
7200BDF	7200BDT	26.2	8.2	14.5	12.5	25.5	27.5	0.6	0.3	0.062
7200CDF	7200CDT	14.5	3.5	14.5	12.5	25.5	27.5	0.6	0.3	0.062
7300DF	7300DT	24.0	2.0	14.5	12.5	30.5	32.5	0.6	0.3	0.108
7901CDF	7901CDT	10.8	1.2	14.5	—	21.5	22.8	0.3	0.15	0.020
7001DF	7001DT	19.9	3.9	14.5	—	25.5	26.8	0.3	0.15	0.048
7001BDF	7001BDT	25.2	9.2	14.5	—	25.5	26.8	0.3	0.15	0.048
7001CDF	7001CDT	13.5	2.5	14.5	—	25.5	26.8	0.3	0.15	0.048
7201DF	7201DT	22.7	2.7	16.5	14.5	27.5	29.5	0.6	0.3	0.076
7201BDF	7201BDT	28.5	8.5	16.5	14.5	27.5	29.5	0.6	0.3	0.076
7201CDF	7201CDT	15.9	4.1	16.5	14.5	27.5	29.5	0.6	0.3	0.076
7301DF	7301DT	26.2	2.2	17.5	16.5	31.5	32.5	1	0.6	0.130
7902CDF	7902CDT	12.8	1.2	17.5	—	25.5	26.8	0.3	0.15	0.030
7002DF	7002DT	22.6	4.6	17.5	—	29.5	30.8	0.3	0.15	0.070
7002BDF	7002BDT	29.1	11.1	17.5	—	29.5	30.8	0.3	0.15	0.070
7002CDF	7002CDT	15.3	2.7	17.5	—	29.5	30.8	0.3	0.15	0.070
7202DF	7202DT	25.7	3.7	19.5	17.5	30.5	32.5	0.6	0.3	0.096
7202BDF	7202BDT	32.4	10.4	19.5	17.5	30.5	32.5	0.6	0.3	0.096
7202CDF	7202CDT	17.8	4.2	19.5	17.5	30.5	32.5	0.6	0.3	0.096
7302DF	7302DT	30.0	4.0	20.5	19.5	36.5	37.5	1	0.6	0.176
7903CDF	7903CDT	13.4	0.6	19.5	—	27.5	28.8	0.3	0.15	0.032
7003DF	7003DT	25.3	5.3	19.5	—	32.5	33.8	0.3	0.15	0.090

2) B, C or no indication after the bearing number indicates nominal contact angle of 40°, 15° and 30° respectively.

[Remark] Standard cage types used for the above bearings are described earlier in this section.

Angular contact ball bearings (matched pair)

d (17) ~ (25) mm

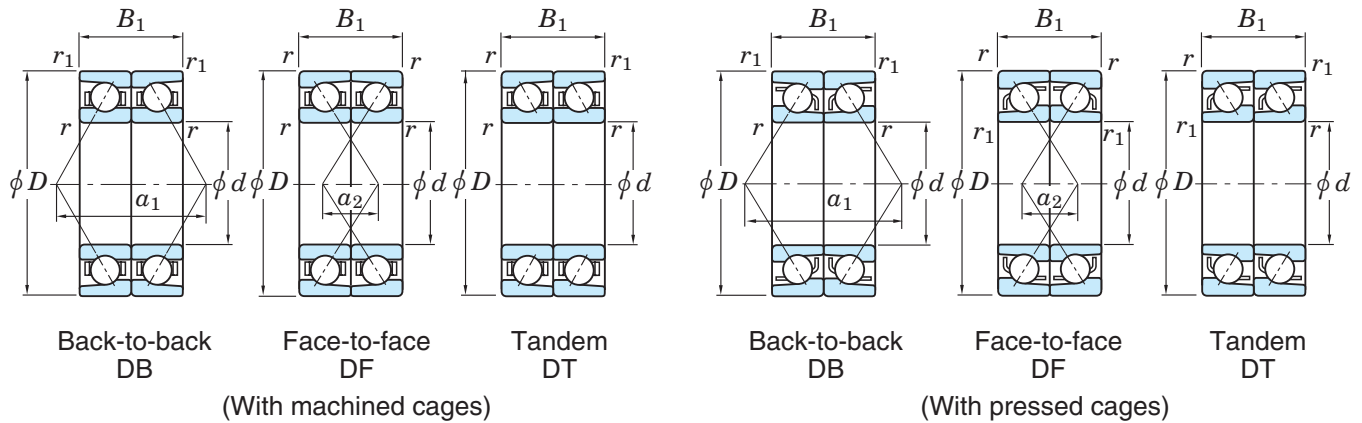

Boundary dimensions (mm)					Basic load ratings (kN)				Factor	Limiting speeds ¹⁾ (min ⁻¹)		Back-to-back DB
d	D	B_1	$r_{\min.}$	$r_{1\min.}$	With machined cages		With pressed cages			Grease lub.	Oil lub.	
					C_r	C_{Or}	C_r	C_{Or}	f_0			
17	35	20	0.3	0.15	9.90	7.50	—	—	—	14 000	18 000	7003BDB
	35	20	0.3	0.15	11.9	8.95	—	—	14.6	25 000	33 000	7003CDB
	40	24	0.6	0.3	16.5	11.0	16.5	11.0	—	17 000	21 000	7203DB
	40	24	0.6	0.3	15.2	10.1	15.2	10.1	—	12 000	17 000	7203BDB
	40	24	0.6	0.3	17.7	11.8	17.7	11.8	13.4	23 000	30 000	7203CDB
	47	28	1	0.6	24.2	15.8	26.0	17.5	—	15 000	18 000	7303DB
	47	28	1	0.6	22.5	14.6	24.1	16.2	—	11 000	15 000	7303BDB
	47	28	1	0.6	25.7	16.8	25.7	16.8	12.6	20 000	27 000	7303CDB
20	37	18	0.3	0.15	11.8	9.15	—	—	14.9	24 000	31 000	7904CDB
	42	24	0.6	0.3	16.7	12.2	—	—	—	15 000	19 000	7004DB
	42	24	0.6	0.3	15.2	11.1	—	—	—	11 000	15 000	7004BDB
	42	24	0.6	0.3	18.0	13.2	—	—	14.1	21 000	28 000	7004CDB
	47	28	1	0.6	23.5	16.8	24.9	18.3	—	14 000	17 000	7204DB
	47	28	1	0.6	21.6	15.4	22.9	16.8	—	10 000	14 000	7204BDB
	47	28	1	0.6	25.2	18.0	26.7	19.6	13.4	19 000	26 000	7204CDB
	52	30	1.1	0.6	28.3	18.8	30.4	20.8	—	13 000	17 000	7304DB
	52	30	1.1	0.6	26.3	17.4	28.2	19.3	—	10 000	13 000	7304BDB
	52	30	1.1	0.6	30.1	19.9	32.3	22.2	12.6	18 000	24 000	7304CDB
	72	38	1.1	0.6	57.8	38.2	—	—	—	7 400	11 000	7404DB
	72	38	1.1	0.6	54.4	35.9	—	—	—	6 400	9 600	7404BDB
25	42	18	0.3	0.15	12.7	10.9	—	—	15.5	20 000	27 000	7905CDB
	47	24	0.6	0.3	18.3	14.8	—	—	—	13 000	17 000	7005DB
	47	24	0.6	0.3	16.6	13.4	—	—	—	10 000	13 000	7005BDB
	47	24	0.6	0.3	20.0	16.0	—	—	14.7	18 000	24 000	7005CDB
	52	30	1	0.6	24.9	19.0	26.3	20.6	—	12 000	15 000	7205DB
	52	30	1	0.6	22.7	17.4	24.0	18.8	—	9 200	12 000	7205BDB
	52	30	1	0.6	26.9	20.5	28.4	22.2	14.0	17 000	23 000	7205CDB

[Notes] 1) Limiting speeds shown above are applicable to machined cage bearings. Limiting speeds of pressed cage bearings should be kept to under 80% of this value. For bearings with 15° contact angle, this figure is applied to the high precision bearings ranked higher than class 5, used with machined cages or molded cages.

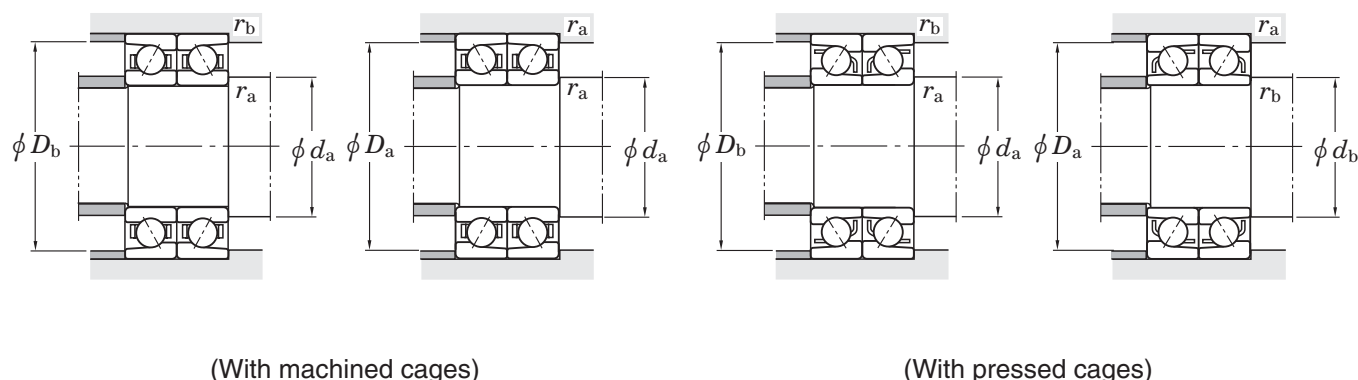

(With machined cages)

(With pressed cages)

Bearing No. ²⁾		Load center spread (mm)		Mounting dimensions (mm)						(Refer.) Mass (kg)
Face-to-face DF	Tandem DT	a_1	a_2	d_a	d_b	D_a	D_b	r_a	r_b	
				min.	min.	max.	max.	max.	max.	
7003BDF	7003BDT	32.2	12.2	19.5	—	32.5	33.8	0.3	0.15	0.090
7003CDF	7003CDT	17.1	2.9	19.5	—	32.5	33.8	0.3	0.15	0.090
7203DF	7203DT	28.8	4.8	21.5	19.5	35.5	37.5	0.6	0.3	0.140
7203BDF	7203BDT	36.3	12.3	21.5	19.5	35.5	37.5	0.6	0.3	0.140
7203CDF	7203CDT	19.8	4.2	21.5	19.5	35.5	37.5	0.6	0.3	0.140
7303DF	7303DT	33.1	5.1	22.5	21.5	41.5	42.5	1	0.6	0.240
7303BDF	7303BDT	41.7	13.7	22.5	21.5	41.5	42.5	1	0.6	0.240
7303CDF	7303CDT	22.8	5.2	22.5	21.5	41.5	42.5	1	0.6	0.240
7904CDF	7904CDT	16.6	1.4	22.5	—	34.5	35.8	0.3	0.15	0.070
7004DF	7004DT	30.2	6.2	24.5	—	37.5	39.5	0.6	0.3	0.158
7004BDF	7004BDT	38.4	14.4	24.5	—	37.5	39.5	0.6	0.3	0.158
7004CDF	7004CDT	20.4	3.6	24.5	—	37.5	39.5	0.6	0.3	0.158
7204DF	7204DT	33.9	5.9	25.5	24.5	41.5	42.5	1	0.6	0.224
7204BDF	7204BDT	42.9	14.9	25.5	24.5	41.5	42.5	1	0.6	0.224
7204CDF	7204CDT	23.2	4.8	25.5	24.5	41.5	42.5	1	0.6	0.224
7304DF	7304DT	35.8	5.8	27	24.5	45	47.5	1	0.6	0.300
7304BDF	7304BDT	45.2	15.2	27	24.5	45	47.5	1	0.6	0.300
7304CDF	7304CDT	24.6	5.4	27	24.5	45	47.5	1	0.6	0.300
7404DF	7404DT	46.1	8.1	27	—	65	67.5	1	0.6	0.790
7404BDF	7404BDT	58.4	20.4	27	—	65	67.5	1	0.6	0.790
7905CDF	7905CDT	18.2	0.2	27.5	—	39.5	40.8	0.3	0.15	0.082
7005DF	7005DT	32.9	8.9	29.5	—	42.5	44.5	0.6	0.3	0.182
7005BDF	7005BDT	42.3	18.3	29.5	—	42.5	44.5	0.6	0.3	0.182
7005CDF	7005CDT	21.7	2.3	29.5	—	42.5	44.5	0.6	0.3	0.182
7205DF	7205DT	37.5	7.5	30.5	29.5	46.5	47.5	1	0.6	0.270
7205BDF	7205BDT	47.7	17.7	30.5	29.5	46.5	47.5	1	0.6	0.270
7205CDF	7205CDT	25.5	4.5	30.5	29.5	46.5	47.5	1	0.6	0.270

2) B, C or no indication after the bearing number indicates nominal contact angle of 40°, 15° and 30° respectively.

[Remark] Standard cage types used for the above bearings are described earlier in this section.

Angular contact ball bearings (matched pair)

d (25) ~ (35) mm

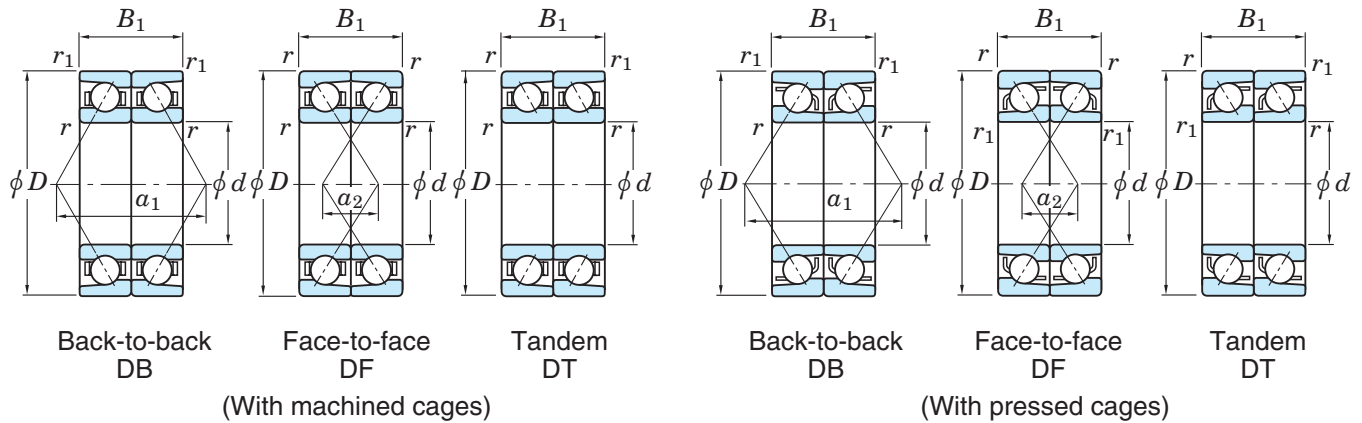

Boundary dimensions (mm)					Basic load ratings (kN)				Factor	Limiting speeds ¹⁾ (min ⁻¹)		Back-to-back DB
d	D	B_1	$r_{\min.}$	$r_{1\min.}$	With machined cages		With pressed cages			Grease lub.	Oil lub.	
25	62	34	1.1	0.6	40.3	28.8	42.9	31.6	—	11 000	14 000	7305DB
	62	34	1.1	0.6	37.2	26.6	39.6	29.2	—	8 300	11 000	7305BDB
	62	34	1.1	0.6	42.8	30.6	45.6	33.7	12.8	15 000	20 000	7305CDB
	80	42	1.5	1	64.5	46.3	69.2	51.5	—	6 400	9 100	7405DB
	80	42	1.5	1	60.0	43.0	64.3	47.8	—	5 500	8 200	7405BDB
30	47	18	0.3	0.15	13.5	12.5	—	—	15.9	18 000	23 000	7906CDB
	55	26	1	0.6	14.2	9.75	—	—	7.9	21 000	32 000	HAR006CDB
	55	26	1	0.6	23.6	20.2	—	—	—	11 000	14 000	7006DB
	55	26	1	0.6	21.3	18.4	—	—	—	8 500	11 000	7006BDB
	55	26	1	0.6	25.7	22.0	—	—	14.9	16 000	21 000	7006CDB
	62	32	1	0.6	34.7	27.4	36.6	29.7	—	10 000	13 000	7206DB
	62	32	1	0.6	31.6	25.0	33.3	27.1	—	7 700	10 000	7206BDB
	62	32	1	0.6	37.4	29.5	39.5	32.0	14.0	14 000	19 000	7206CDB
	72	38	1.1	0.6	48.9	37.8	51.8	41.2	—	9 200	12 000	7306DB
	72	38	1.1	0.6	44.9	34.7	47.5	37.9	—	6 900	9 200	7306BDB
	72	38	1.1	0.6	52.5	40.5	55.6	44.2	13.4	13 000	17 000	7306CDB
	90	46	1.5	1	77.3	56.9	82.9	63.2	—	5 700	8 100	7406DB
90	46	1.5	1	71.8	52.8	77.0	58.6	—	4 900	7 300	7406BDB	
35	55	20	0.6	0.3	20.4	19.4	—	—	15.7	15 000	20 000	7907CDB
	62	28	1	0.6	15.0	11.1	—	—	8.1	18 000	28 000	HAR007CDB
	62	28	1	0.6	28.4	25.2	—	—	—	9 800	12 000	7007DB
	62	28	1	0.6	25.7	22.8	—	—	—	7 300	9 800	7007BDB
	62	28	1	0.6	31.0	27.4	—	—	15.0	13 000	18 000	7007CDB
	72	34	1.1	0.6	45.7	37.3	48.2	40.4	—	8 800	11 000	7207DB
	72	34	1.1	0.6	41.6	34.1	43.9	36.9	—	6 600	8 800	7207BDB
	72	34	1.1	0.6	49.4	40.2	52.1	43.5	14.0	12 000	16 000	7207CDB
	80	42	1.5	1	57.5	44.0	64.9	52.8	—	8 200	10 000	7307DB

[Notes] 1) Limiting speeds shown above are applicable to machined cage bearings. Limiting speeds of pressed cage bearings should be kept to under 80% of this value. For bearings with 15° contact angle, this figure is applied to the high precision bearings ranked higher than class 5, used with machined cages or molded cages.

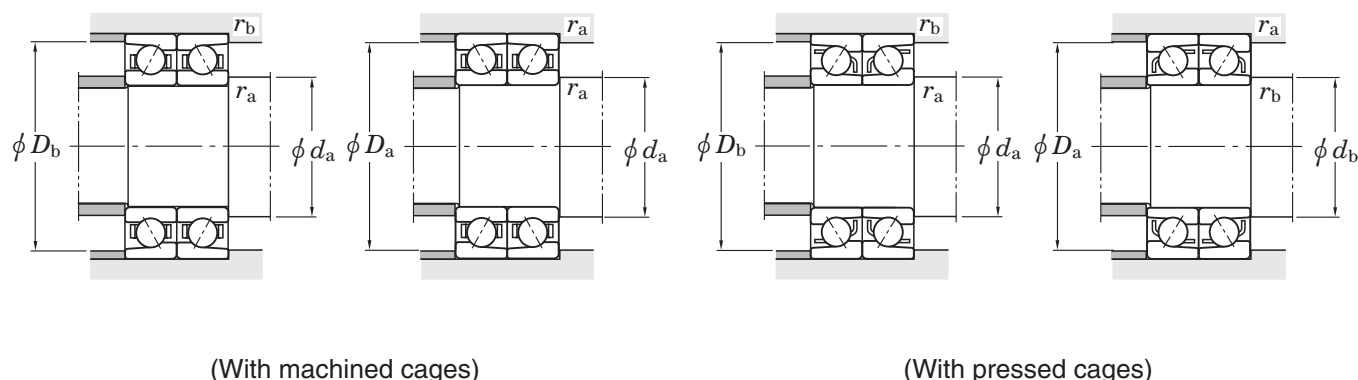

Bearing No. ²⁾		Load center spread (mm)		Mounting dimensions (mm)						(Refer.) Mass (kg)
Face-to-face DF	Tandem DT	a_1	a_2	d_a	d_b	D_a	D_b	r_a	r_b	
				min.	min.	max.	max.	max.	max.	
7305DF	7305DT	42.1	8.1	32	29.5	55	57.5	1	0.6	0.486
7305BDF	7305BDT	53.5	19.5	32	29.5	55	57.5	1	0.6	0.486
7305CDF	7305CDT	28.7	5.3	32	29.5	55	57.5	1	0.6	0.486
7405DF	7405DT	52.8	10.8	33.5	30.5	71.5	74.5	1.5	1	1.05
7405BDF	7405BDT	67.2	25.2	33.5	30.5	71.5	74.5	1.5	1	1.05
7906CDF	7906CDT	19.3	1.3	32.5	—	44.5	45.8	0.3	0.15	0.092
HAR006CDF	HAR006CDT	24.4	1.6	35.5	—	49.5	50.5	1	0.6	0.232
7006DF	7006DT	37.5	11.5	35.5	—	49.5	50.5	1	0.6	0.266
7006BDF	7006BDT	48.7	22.7	35.5	—	49.5	50.5	1	0.6	0.266
7006CDF	7006CDT	24.4	1.6	35.5	—	49.5	50.5	1	0.6	0.266
7206DF	7206DT	43.0	11.0	35.5	34.5	56.5	57.5	1	0.6	0.416
7206BDF	7206BDT	55.2	23.2	35.5	34.5	56.5	57.5	1	0.6	0.416
7206CDF	7206CDT	28.5	3.5	35.5	34.5	56.5	57.5	1	0.6	0.416
7306DF	7306DT	49.0	11.0	37	34.5	65	67.5	1	0.6	0.724
7306BDF	7306BDT	62.6	24.6	37	34.5	65	67.5	1	0.6	0.724
7306CDF	7306CDT	32.9	5.1	37	34.5	65	67.5	1	0.6	0.724
7406DF	7406DT	58.5	12.5	38.5	35.5	81.5	84.5	1.5	1	1.37
7406BDF	7406BDT	74.6	28.6	38.5	35.5	81.5	84.5	1.5	1	1.37
7907CDF	7907CDT	22.1	2.1	39.5	—	50.5	52.5	0.6	0.3	0.148
HAR007CDF	HAR007CDT	27.0	1.0	40.5	—	56.5	57.5	1	0.6	0.316
7007DF	7007DT	42.3	14.3	40.5	—	56.5	57.5	1	0.6	0.340
7007BDF	7007BDT	55.1	27.1	40.5	—	56.5	57.5	1	0.6	0.340
7007CDF	7007CDT	27.0	1.0	40.5	—	56.5	57.5	1	0.6	0.340
7207DF	7207DT	48.5	14.5	42	39.5	65	67.5	1	0.6	0.590
7207BDF	7207BDT	62.7	28.7	42	39.5	65	67.5	1	0.6	0.590
7207CDF	7207CDT	31.6	2.4	42	39.5	65	67.5	1	0.6	0.590
7307DF	7307DT	54.8	12.8	43.5	40.5	71.5	74.5	1.5	1	0.950

2) B, C or no indication after the bearing number indicates nominal contact angle of 40°, 15° and 30° respectively.

[Remark] Standard cage types used for the above bearings are described earlier in this section.

Angular contact ball bearings (matched pair)

d (35) ~ (45) mm

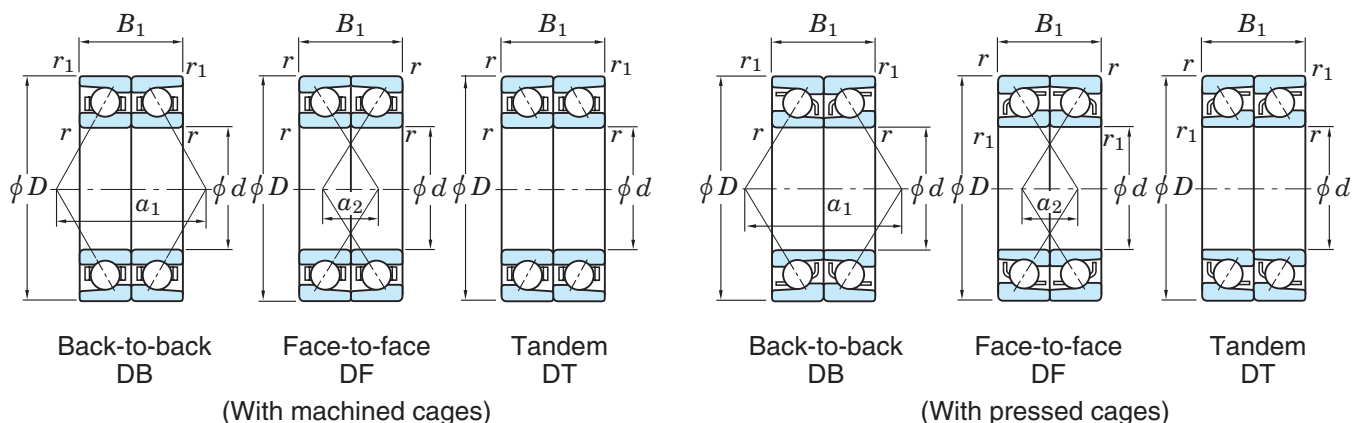

Boundary dimensions (mm)					Basic load ratings (kN)				Factor	Limiting speeds ¹⁾ (min ⁻¹)		Back-to-back DB
d	D	B_1	$r_{\min.}$	$r_{1\min.}$	With machined cages		With pressed cages			Grease lub.	Oil lub.	
35	80	42	1.5	1	52.7	40.5	59.5	48.6	—	6 200	8 200	7307BDB
	80	42	1.5	1	61.6	47.2	69.6	56.6	13.4	11 000	15 000	7307CDB
	100	50	1.5	1	98.2	73.9	105	82.1	—	5 000	7 200	7407DB
	100	50	1.5	1	91.3	68.6	97.9	76.2	—	4 300	6 500	7407BDB
40	62	24	0.6	0.3	25.6	24.9	—	—	15.7	13 000	18 000	7908CDB
	62	24	0.6	0.3	10.3	8.15	—	—	8.4	17 000	27 000	HAR908CDB
	68	30	1	0.6	15.8	12.4	—	—	8.2	16 000	25 000	HAR008CDB
	68	30	1	0.6	30.4	29.2	—	—	—	8 900	11 000	7008DB
	68	30	1	0.6	27.4	26.4	—	—	—	6 600	8 900	7008BDB
	68	30	1	0.6	33.4	31.8	—	—	15.4	12 000	16 000	7008CDB
	80	36	1.1	0.6	54.6	46.7	57.4	50.3	—	8 000	10 000	7208DB
	80	36	1.1	0.6	49.7	42.7	52.2	45.9	—	6 000	8 000	7208BDB
	80	36	1.1	0.6	59.1	50.4	62.0	54.3	14.2	11 000	15 000	7208CDB
	90	46	1.5	1	70.2	54.9	79.3	65.9	—	7 400	9 200	7308DB
	90	46	1.5	1	64.5	50.5	72.8	60.6	—	5 500	7 400	7308BDB
	90	46	1.5	1	75.3	58.8	85.0	70.5	13.4	10 000	14 000	7308CDB
	110	54	2	1	114	87.1	122	96.8	—	4 600	6 600	7408DB
	110	54	2	1	105	80.8	113	89.8	—	3 900	5 900	7408BDB
45	68	24	0.6	0.3	27.0	28.2	—	—	16.0	12 000	16 000	7909CDB
	68	24	0.6	0.3	11.0	9.35	—	—	8.5	16 000	24 000	HAR909CDB
	75	32	1	0.6	17.6	14.2	—	—	8.3	15 000	23 000	HAR009CDB
	75	32	1	0.6	36.2	35.4	—	—	—	8 000	10 000	7009DB
	75	32	1	0.6	32.5	32.0	—	—	—	6 000	8 000	7009BDB
	75	32	1	0.6	39.6	38.5	—	—	15.4	11 000	15 000	7009CDB
	85	38	1.1	0.6	61.3	53.2	64.4	57.2	—	7 500	9 400	7209DB
	85	38	1.1	0.6	55.8	48.6	58.6	52.3	—	5 600	7 500	7209BDB
	85	38	1.1	0.6	66.3	57.4	69.7	61.8	14.2	10 000	14 000	7209CDB

[Notes] 1) Limiting speeds shown above are applicable to machined cage bearings.
 Limiting speeds of pressed cage bearings should be kept to under 80% of this value.
 For bearings with 15° contact angle, this figure is applied to the high precision bearings ranked higher than class 5, used with machined cages or molded cages.

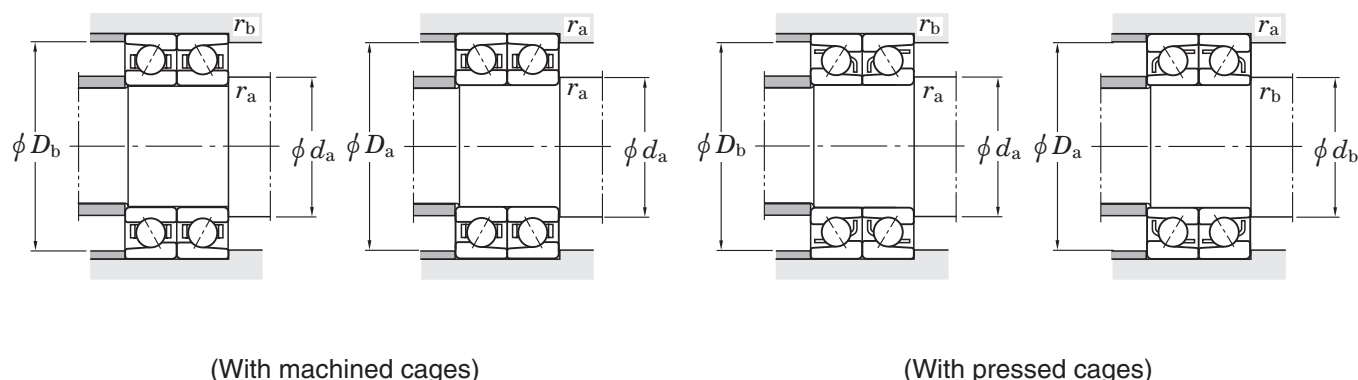

Bearing No. ²⁾		Load center spread (mm)		Mounting dimensions (mm)						(Refer.) Mass (kg)
Face-to-face DF	Tandem DT	a_1	a_2	d_a	d_b	D_a	D_b	r_a	r_b	
				min.	min.	max.	max.	max.	max.	
7307BDF	7307BDT	70.1	28.1	43.5	40.5	71.5	74.5	1.5	1	0.950
7307CDF	7307CDT	36.7	5.3	43.5	40.5	71.5	74.5	1.5	1	0.950
7407DF	7407DT	65.2	15.2	43.5	40.5	91.5	94.5	1.5	1	1.90
7407BDF	7407BDT	83.3	33.3	43.5	40.5	91.5	94.5	1.5	1	1.90
7908CDF	7908CDT	25.7	1.7	44.5	—	57.5	59.5	0.6	0.3	0.214
HAR908CDF	HAR908CDT	25.7	1.7	44.5	—	57.5	59.5	0.6	0.3	0.230
HAR008CDF	HAR008CDT	29.5	0.5	45.5	—	62.5	63.5	1	0.6	0.400
7008DF	7008DT	46.3	16.3	45.5	—	62.5	63.5	1	0.6	0.420
7008BDF	7008BDT	60.5	30.5	45.5	—	62.5	63.5	1	0.6	0.420
7008CDF	7008CDT	29.5	0.5	45.5	—	62.5	63.5	1	0.6	0.420
7208DF	7208DT	52.7	16.7	47	44.5	73	75.5	1	0.6	0.764
7208BDF	7208BDT	68.3	32.3	47	44.5	73	75.5	1	0.6	0.764
7208CDF	7208CDT	34.1	1.9	47	44.5	73	75.5	1	0.6	0.764
7308DF	7308DT	60.5	14.5	48.5	45.5	81.5	84.5	1.5	1	1.31
7308BDF	7308BDT	77.5	31.5	48.5	45.5	81.5	84.5	1.5	1	1.31
7308CDF	7308CDT	40.4	5.6	48.5	45.5	81.5	84.5	1.5	1	1.31
7408DF	7408DT	70.9	16.9	50	45.5	100	104.5	2	1	2.46
7408BDF	7408BDT	90.8	36.8	50	45.5	100	104.5	2	1	2.46
7909CDF	7909CDT	27.1	3.1	49.5	—	63.5	65.5	0.6	0.3	0.254
HAR909CDF	HAR909CDT	27.1	3.1	49.5	—	63.5	65.5	0.6	0.3	0.272
HAR009CDF	HAR009CDT	32.1	0.1	50.5	—	69.5	70.5	1	0.6	0.502
7009DF	7009DT	50.7	18.7	50.5	—	69.5	70.5	1	0.6	0.520
7009BDF	7009BDT	66.3	34.3	50.5	—	69.5	70.5	1	0.6	0.520
7009CDF	7009CDT	32.1	0.1	50.5	—	69.5	70.5	1	0.6	0.520
7209DF	7209DT	56.0	18.0	52	49.5	78	80.5	1	0.6	0.860
7209BDF	7209BDT	72.8	34.8	52	49.5	78	80.5	1	0.6	0.860
7209CDF	7209CDT	36.2	1.8	52	49.5	78	80.5	1	0.6	0.860

2) B, C or no indication after the bearing number indicates nominal contact angle of 40°, 15° and 30° respectively.

[Remark] Standard cage types used for the above bearings are described earlier in this section.

Angular contact ball bearings (matched pair)

d (45) ~ (55) mm

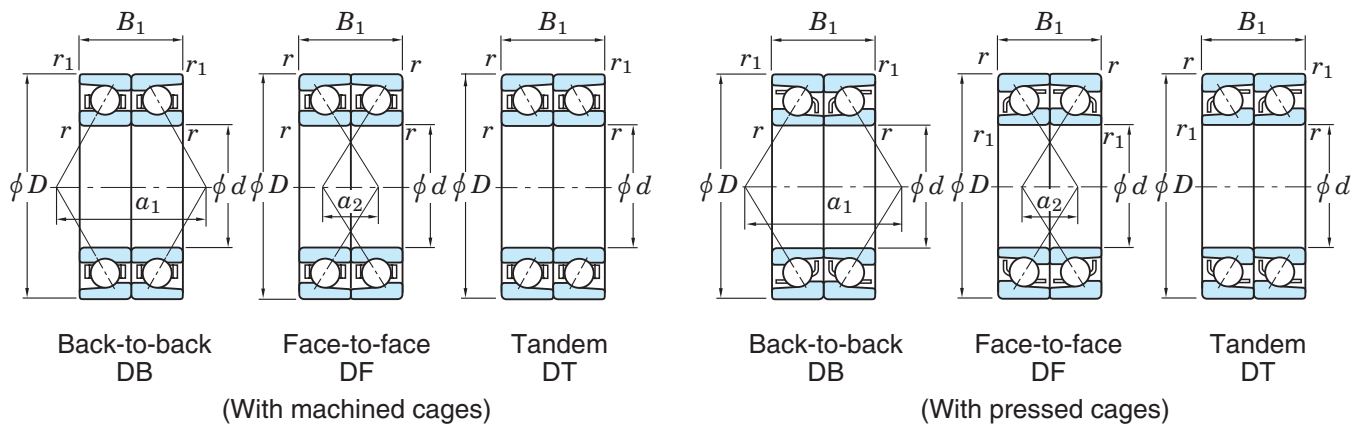

Boundary dimensions (mm)					Basic load ratings (kN)				Factor	Limiting speeds ¹⁾ (min ⁻¹)		Back-to-back DB
d	D	B_1	$r_{\min.}$	$r_{1\min.}$	With machined cages		With pressed cages			Grease lub.	Oil lub.	
45	100	50	1.5	1	89.6	74.2	94.9	80.9	—	6 600	8 200	7309DB
	100	50	1.5	1	82.1	68.2	87.1	74.3	—	4 900	6 600	7309BDB
	100	50	1.5	1	96.1	79.5	102	86.7	13.5	9 000	12 000	7309CDB
	120	58	2	1	138	108	148	120	—	4 200	6 000	7409DB
	120	58	2	1	128	100	138	111	—	3 600	5 400	7409BDB
50	72	24	0.6	0.3	28.3	31.4	—	—	16.2	11 000	15 000	7910CDB
	72	24	0.6	0.3	14.8	12.6	—	—	8.5	14 000	22 000	HAR910CDB
	80	32	1	0.6	18.5	15.7	—	—	8.4	14 000	21 000	HAR010CDB
	80	32	1	0.6	38.4	40.2	—	—	—	7 300	9 200	7010DB
	80	32	1	0.6	34.5	36.2	—	—	—	5 500	7 400	7010BDB
	80	32	1	0.6	42.2	43.9	—	—	15.7	10 000	13 000	7010CDB
	90	40	1.1	0.6	64.0	58.7	67.0	62.9	—	6 800	8 500	7210DB
	90	40	1.1	0.6	58.0	53.5	60.7	57.3	—	5 100	6 800	7210BDB
	90	40	1.1	0.6	69.6	63.6	72.8	68.1	14.6	9 400	12 000	7210CDB
	110	54	2	1	114	96.3	121	105	—	5 800	7 300	7310DB
	110	54	2	1	105	88.6	111	96.6	—	4 400	5 800	7310BDB
	110	54	2	1	122	103	129	112	13.4	8 000	11 000	7310CDB
	130	62	2.1	1.1	158	131	—	—	—	3 800	5 500	7410DB
130	62	2.1	1.1	147	121	—	—	—	3 300	4 900	7410BDB	
55	80	26	1	0.6	32.0	37.0	—	—	16.3	10 000	14 000	7911CDB
	80	26	1	0.6	16.4	15.3	—	—	8.6	13 000	20 000	HAR911CDB
	90	36	1.1	0.6	22.9	19.8	—	—	8.4	12 000	19 000	HAR011CDB
	90	36	1.1	0.6	50.5	52.5	—	—	—	6 600	8 300	7011DB
	90	36	1.1	0.6	45.4	47.5	—	—	—	5 000	6 600	7011BDB
	90	36	1.1	0.6	55.4	57.3	—	—	15.5	9 100	12 000	7011CDB
	100	42	1.5	1	79.1	74.2	82.8	79.6	—	6 100	7 600	7211DB
	100	42	1.5	1	71.6	67.6	75.0	72.4	—	4 600	6 100	7211BDB

[Notes] 1) Limiting speeds shown above are applicable to machined cage bearings.
 Limiting speeds of pressed cage bearings should be kept to under 80% of this value.
 For bearings with 15° contact angle, this figure is applied to the high precision bearings ranked higher than class 5, used with machined cages or molded cages.

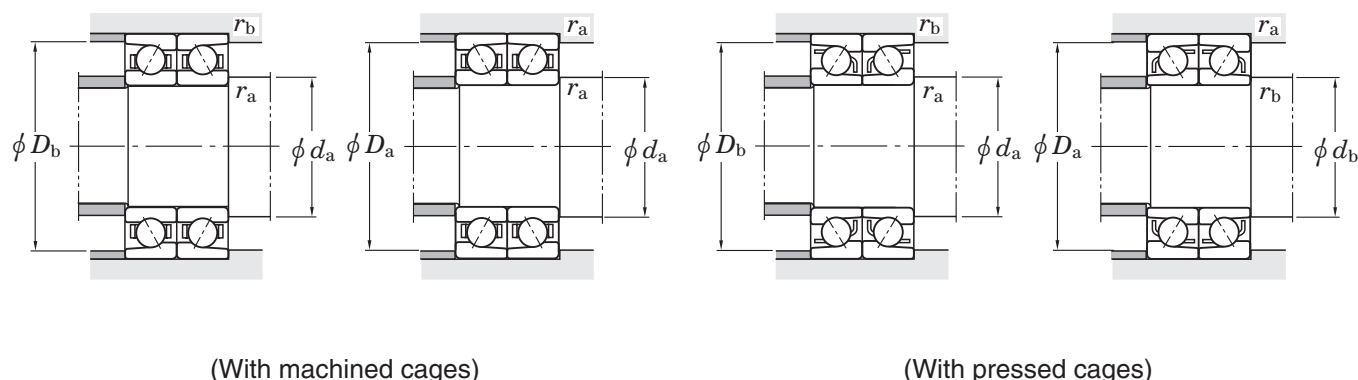

Bearing No. ²⁾		Load center spread (mm)		Mounting dimensions (mm)						(Refer.) Mass (kg)
Face-to-face DF	Tandem DT	a_1	a_2	d_a	d_b	D_a	D_b	r_a	r_b	
				min.	min.	max.	max.	max.	max.	
7309DF	7309DT	67.2	17.2	53.5	50.5	91.5	94.5	1.5	1	1.75
7309BDF	7309BDT	86.3	36.3	53.5	50.5	91.5	94.5	1.5	1	1.75
7309CDF	7309CDT	44.6	5.4	53.5	50.5	91.5	94.5	1.5	1	1.75
7409DF	7409DT	77.2	19.2	55	50.5	110	114.5	2	1	3.10
7409BDF	7409BDT	99.1	41.1	55	50.5	110	114.5	2	1	3.10
7910CDF	7910CDT	28.3	4.3	54.5	—	67.5	69.5	0.6	0.3	0.256
HAR910CDF	HAR910CDT	28.3	4.3	54.5	—	67.5	69.5	0.6	0.3	0.262
HAR010CDF	HAR010CDT	33.4	1.4	55.5	—	74.5	75.5	1	0.6	0.546
7010DF	7010DT	53.8	21.8	55.5	—	74.5	75.5	1	0.6	0.580
7010BDF	7010BDT	70.5	38.5	55.5	—	74.5	75.5	1	0.6	0.580
7010CDF	7010CDT	33.6	1.6	55.5	—	74.5	75.5	1	0.6	0.580
7210DF	7210DT	60.7	20.7	57	54.5	83	85.5	1	0.6	0.970
7210BDF	7210BDT	79.2	39.2	57	54.5	83	85.5	1	0.6	0.970
7210CDF	7210CDT	38.9	1.1	57	54.5	83	85.5	1	0.6	0.970
7310DF	7310DT	74.4	20.4	60	55.5	100	104.5	2	1	2.28
7310BDF	7310BDT	95.8	41.8	60	55.5	100	104.5	2	1	2.28
7310CDF	7310CDT	49.0	5.0	60	55.5	100	104.5	2	1	2.28
7410DF	7410DT	83.3	21.3	62	—	118	123	2	1	3.84
7410BDF	7410BDT	106.9	44.9	62	—	118	123	2	1	3.84
7911CDF	7911CDT	31.1	5.1	60.5	—	74.5	75.5	1	0.6	0.356
HAR911CDF	HAR911CDT	31.1	5.1	60.5	—	74.5	75.5	1	0.6	0.378
HAR011CDF	HAR011CDT	37.4	1.4	62	—	83	85.5	1	0.6	0.806
7011DF	7011DT	59.9	23.9	62	—	83	85.5	1	0.6	0.840
7011BDF	7011BDT	78.8	42.8	62	—	83	85.5	1	0.6	0.840
7011CDF	7011CDT	37.4	1.4	62	—	83	85.5	1	0.6	0.840
7211DF	7211DT	66.6	24.6	63.5	60.5	91.5	94.5	1.5	1	1.27
7211BDF	7211BDT	87.3	45.3	63.5	60.5	91.5	94.5	1.5	1	1.27

2) B, C or no indication after the bearing number indicates nominal contact angle of 40°, 15° and 30° respectively.

[Remark] Standard cage types used for the above bearings are described earlier in this section.

Angular contact ball bearings (matched pair)

d (55) ~ (65) mm

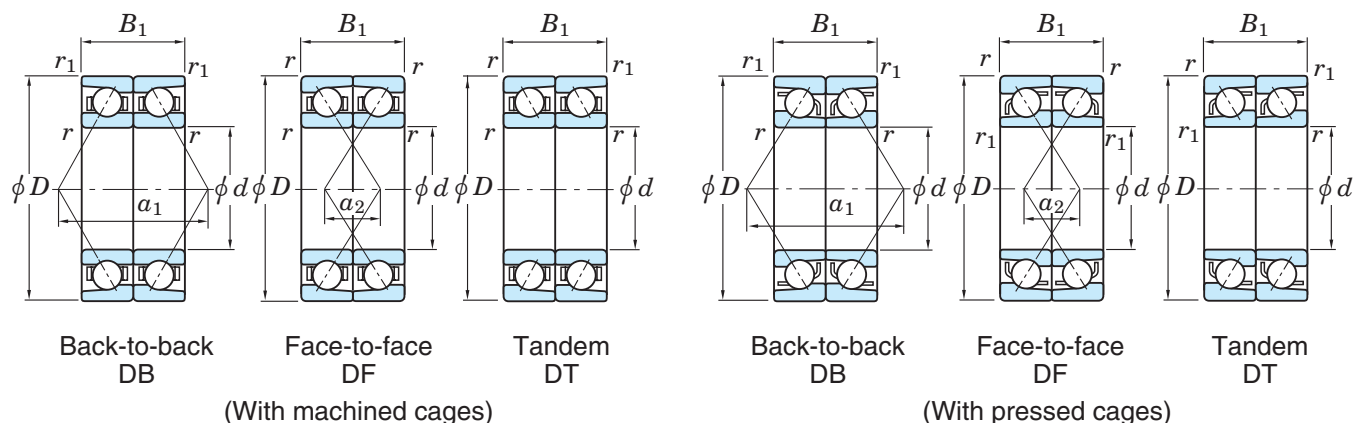

Boundary dimensions (mm)					Basic load ratings (kN)				Factor	Limiting speeds ¹⁾ (min ⁻¹)		Back-to-back DB
d	D	B_1	$r_{\min.}$	$r_{1\min.}$	With machined cages		With pressed cages			Grease lub.	Oil lub.	
					C_r	C_{Or}	C_r	C_{Or}	f_0			
55	100	42	1.5	1	85.9	80.4	90.0	86.1	14.6	8 400	11 000	7211CDB
	120	58	2	1	132	113	139	123	—	5 400	6 700	7311DB
	120	58	2	1	121	104	128	113	—	4 000	5 400	7311BDB
	120	58	2	1	141	121	149	132	13.4	7 400	9 800	7311CDB
	140	66	2.1	1.1	192	165	—	—	—	3 500	5 000	7411DB
	140	66	2.1	1.1	179	153	—	—	—	3 000	4 500	7411BDB
60	85	26	1	0.6	37.8	43.6	—	—	16.3	9 100	13 000	7912CDB
	85	26	1	0.6	16.2	15.5	—	—	8.6	12 000	19 000	HAR912CDB
	95	36	1.1	0.6	23.9	21.7	—	—	8.5	11 000	18 000	HAR012CDB
	95	36	1.1	0.6	51.8	56.1	—	—	—	6 200	7 700	7012DB
	95	36	1.1	0.6	46.4	50.7	—	—	—	4 600	6 200	7012BDB
	95	36	1.1	0.6	56.9	61.3	—	—	15.7	8 500	11 000	7012CDB
	110	44	1.5	1	95.7	91.5	100	98.0	—	5 500	6 900	7212DB
	110	44	1.5	1	86.8	83.3	90.8	89.2	—	4 100	5 500	7212BDB
	110	44	1.5	1	104	99.0	109	106	14.5	7 500	10 000	7212CDB
	130	62	2.1	1.1	150	131	159	143	—	5 000	6 200	7312DB
	130	62	2.1	1.1	138	121	146	132	—	3 700	5 000	7312BDB
	130	62	2.1	1.1	161	141	171	153	13.4	6 800	9 100	7312CDB
150	70	2.1	1.1	209	187	—	—	—	3 200	4 600	7412DB	
150	70	2.1	1.1	194	173	—	—	—	2 800	4 100	7412BDB	
65	90	26	1	0.6	33.7	42.3	—	—	16.5	8 600	12 000	7913CDB
	90	26	1	0.6	19.1	18.9	—	—	8.6	11 000	18 000	HAR913CDB
	100	36	1.1	0.6	24.8	23.5	—	—	8.5	11 000	16 000	HAR013CDB
	100	36	1.1	0.6	54.7	62.8	—	—	—	5 800	7 200	7013DB
	100	36	1.1	0.6	48.9	56.6	—	—	—	4 300	5 800	7013BDB
	100	36	1.1	0.6	60.2	68.7	—	—	15.9	7 900	11 000	7013CDB
	120	46	1.5	1	109	108	114	116	—	5 200	6 400	7213DB

[Notes] 1) Limiting speeds shown above are applicable to machined cage bearings. Limiting speeds of pressed cage bearings should be kept to under 80% of this value. For bearings with 15° contact angle, this figure is applied to the high precision bearings ranked higher than class 5, used with machined cages or molded cages.

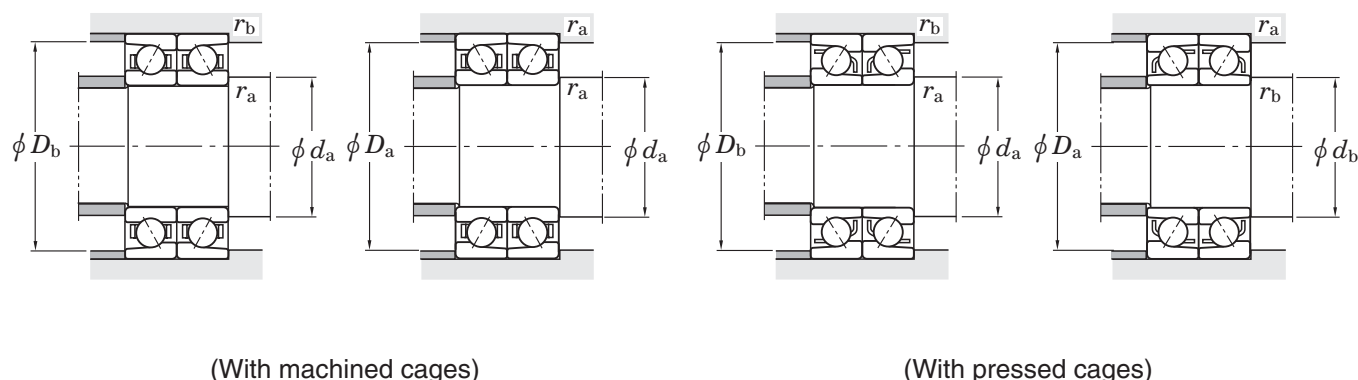

Bearing No. ²⁾		Load center spread (mm)		Mounting dimensions (mm)						(Refer.) Mass (kg)
Face-to-face DF	Tandem DT	a_1	a_2	d_a	d_b	D_a	D_b	r_a	r_b	
				min.	min.	max.	max.	max.	max.	
7211CDF	7211CDT	42.2	0.2	63.5	60.5	91.5	94.5	1.5	1	1.27
7311DF	7311DT	80.4	22.4	65	60.5	110	114.5	2	1	2.90
7311BDF	7311BDT	103.7	45.7	65	60.5	110	114.5	2	1	2.90
7311CDF	7311CDT	52.9	5.1	65	60.5	110	114.5	2	1	2.90
7411DF	7411DT	89.9	23.9	67	—	128	133	2	1	4.72
7411BDF	7411BDT	115.7	49.7	67	—	128	133	2	1	4.72
7912CDF	7912CDT	32.6	6.6	65.5	—	79.5	80.5	1	0.6	0.374
HAR912CDF	HAR912CDT	32.4	6.4	65.5	—	79.5	80.5	1	0.6	0.404
HAR012CDF	HAR012CDT	38.8	2.8	67	—	88	90.5	1	0.6	0.866
7012DF	7012DT	62.8	26.8	67	—	88	90.5	1	0.6	0.900
7012BDF	7012BDT	83.0	47.0	67	—	88	90.5	1	0.6	0.900
7012CDF	7012CDT	38.8	2.8	67	—	88	90.5	1	0.6	0.900
7212DF	7212DT	72.3	28.3	68.5	65.5	101.5	104.5	1.5	1	1.64
7212BDF	7212BDT	95.0	51.0	68.5	65.5	101.5	104.5	1.5	1	1.64
7212CDF	7212CDT	45.3	1.3	68.5	65.5	101.5	104.5	1.5	1	1.64
7312DF	7312DT	86.5	24.5	72	67	118	123	2	1	3.62
7312BDF	7312BDT	111.6	49.6	72	67	118	123	2	1	3.62
7312CDF	7312CDT	56.7	5.3	72	67	118	123	2	1	3.62
7412DF	7412DT	97.0	27.0	72	—	138	143	2	1	5.70
7412BDF	7412BDT	125.1	55.1	72	—	138	143	2	1	5.70
7913CDF	7913CDT	33.8	7.8	70.5	—	84.5	85.5	1	0.6	0.410
HAR913CDF	HAR913CDT	33.8	7.8	70.5	—	84.5	85.5	1	0.6	0.424
HAR013CDF	HAR013CDT	40.1	4.1	72	—	93	95.5	1	0.6	0.924
7013DF	7013DT	65.9	29.9	72	—	93	95.5	1	0.6	0.940
7013BDF	7013BDT	87.6	51.6	72	—	93	95.5	1	0.6	0.940
7013CDF	7013CDT	40.2	4.2	72	—	93	95.5	1	0.6	0.940
7213DF	7213DT	76.4	30.4	73.5	70.5	111.5	114.5	1.5	1	2.04

2) B, C or no indication after the bearing number indicates nominal contact angle of 40°, 15° and 30° respectively.

[Remark] Standard cage types used for the above bearings are described earlier in this section.

Angular contact ball bearings (matched pair)

d (65) ~ (75) mm

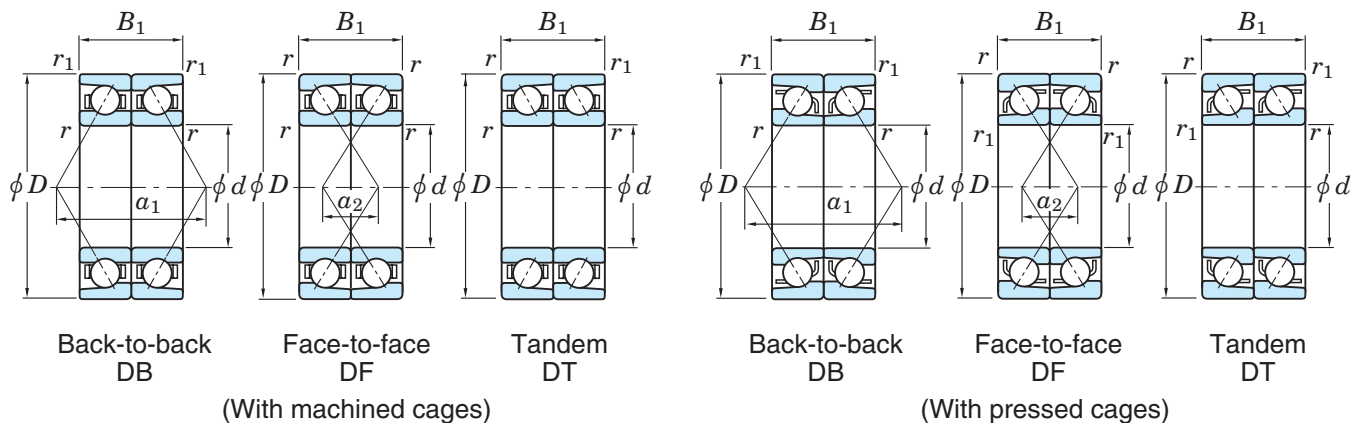

Boundary dimensions (mm)					Basic load ratings (kN)				Factor	Limiting speeds ¹⁾ (min ⁻¹)		Back-to-back DB
d	D	B_1	$r_{\min.}$	$r_{1\min.}$	With machined cages		With pressed cages			Grease lub.	Oil lub.	
					C_r	C_{Or}	C_r	C_{Or}	f_0			
65	120	46	1.5	1	99.0	98.7	103	105	—	3 900	5 200	7213BDB
	120	46	1.5	1	119	117	124	125	14.6	7 100	9 400	7213CDB
	140	66	2.1	1.1	170	151	180	164	—	4 600	5 800	7313DB
	140	66	2.1	1.1	156	139	165	151	—	3 500	4 600	7313BDB
	140	66	2.1	1.1	182	161	193	176	13.4	6 300	8 500	7313CDB
	160	74	2.1	1.1	226	209	—	—	—	3 000	4 300	7413DB
	160	74	2.1	1.1	209	194	—	—	—	2 600	3 900	7413BDB
70	100	32	1	0.6	47.0	58.0	—	—	16.4	7 800	11 000	7914CDB
	100	32	1	0.6	20.9	20.9	—	—	8.7	10 000	16 000	HAR914CDB
	110	40	1.1	0.6	33.7	30.9	—	—	8.4	9 800	15 000	HAR014CDB
	110	40	1.1	0.6	69.3	78.7	—	—	—	5 300	6 600	7014DB
	110	40	1.1	0.6	62.1	71.1	—	—	—	4 000	5 300	7014BDB
	110	40	1.1	0.6	76.2	86.0	—	—	15.7	7 300	9 700	7014CDB
	125	48	1.5	1	113	111	124	127	—	4 900	6 100	7214DB
	125	48	1.5	1	103	101	112	116	—	3 700	4 900	7214BDB
	125	48	1.5	1	123	120	135	138	14.6	6 700	8 900	7214CDB
	150	70	2.1	1.1	191	172	203	187	—	4 300	5 400	7314DB
	150	70	2.1	1.1	175	158	186	172	—	3 200	4 300	7314BDB
	150	70	2.1	1.1	205	184	217	200	13.4	5 900	7 900	7314CDB
	180	84	3	1.1	242	230	—	—	—	2 700	3 900	7414DB
180	84	3	1.1	241	237	—	—	—	2 300	3 500	7414BDB	
75	105	32	1	0.6	47.7	60.9	—	—	16.5	7 400	9 800	7915CDB
	105	32	1	0.6	21.5	22.4	—	—	8.7	9 800	15 000	HAR915CDB
	115	40	1.1	0.6	34.3	32.4	—	—	8.5	9 300	14 000	HAR015CDB
	115	40	1.1	0.6	70.9	83.4	—	—	—	5 000	6 300	7015DB
	115	40	1.1	0.6	63.5	75.2	—	—	—	3 800	5 000	7015BDB
	115	40	1.1	0.6	78.0	91.3	—	—	15.9	6 900	9 200	7015CDB

[Notes] 1) Limiting speeds shown above are applicable to machined cage bearings.
 Limiting speeds of pressed cage bearings should be kept to under 80% of this value.
 For bearings with 15° contact angle, this figure is applied to the high precision bearings ranked higher than class 5, used with machined cages or molded cages.

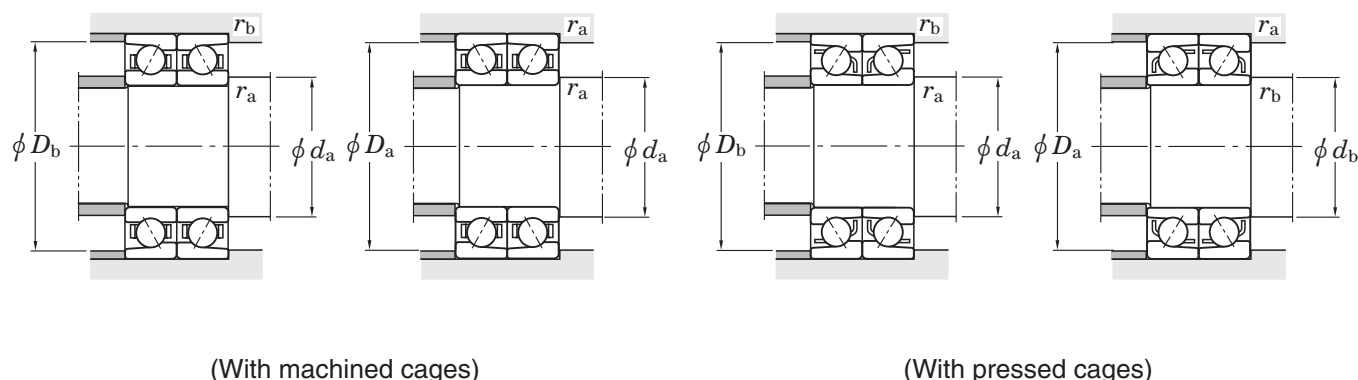

Bearing No. ²⁾		Load center spread (mm)		Mounting dimensions (mm)						(Refer.) Mass (kg)
Face-to-face DF	Tandem DT	a_1	a_2	d_a	d_b	D_a	D_b	r_a	r_b	
				min.	min.	max.	max.	max.	max.	
7213BDF	7213BDT	100.6	54.6	73.5	70.5	111.5	114.5	1.5	1	2.04
7213CDF	7213CDT	47.8	1.8	73.5	70.5	111.5	114.5	1.5	1	2.04
7313DF	7313DT	92.5	26.5	77	72	128	133	2	1	4.44
7313BDF	7313BDT	119.4	53.4	77	72	128	133	2	1	4.44
7313CDF	7313CDT	60.6	5.4	77	72	128	133	2	1	4.44
7413DF	7413DT	102.9	28.9	77	—	148	153	2	1	6.82
7413BDF	7413BDT	132.7	58.7	77	—	148	153	2	1	6.82
7914CDF	7914CDT	38.8	6.8	75.5	—	94.5	95.5	1	0.6	0.664
HAR914CDF	HAR914CDT	38.8	6.8	75.5	—	94.5	95.5	1	0.6	0.712
HAR014CDF	HAR014CDT	44.1	4.1	77	—	103	105.5	1	0.6	1.26
7014DF	7014DT	72.0	32.0	77	—	103	105.5	1	0.6	1.32
7014BDF	7014BDT	95.5	55.5	77	—	103	105.5	1	0.6	1.32
7014CDF	7014CDT	44.1	4.1	77	—	103	105.5	1	0.6	1.32
7214DF	7214DT	80.3	32.3	78.5	75.5	116.5	119.5	1.5	1	2.24
7214BDF	7214BDT	105.8	57.8	78.5	75.5	116.5	119.5	1.5	1	2.24
7214CDF	7214CDT	50.1	2.1	78.5	75.5	116.5	119.5	1.5	1	2.24
7314DF	7314DT	98.5	28.5	82	77	138	143	2	1	5.40
7314BDF	7314BDT	127.3	57.3	82	77	138	143	2	1	5.40
7314CDF	7314CDT	64.5	5.5	82	77	138	143	2	1	5.40
7414DF	7414DT	115.3	31.3	84	—	166	173	2.5	1	9.98
7414BDF	7414BDT	148.4	64.4	84	—	166	173	2.5	1	9.98
7915CDF	7915CDT	40.1	8.1	80.5	—	99.5	100.5	1	0.6	0.700
HAR915CDF	HAR915CDT	40.1	8.1	80.5	—	99.5	100.5	1	0.6	0.740
HAR015CDF	HAR015CDT	45.5	5.5	82	—	108	110.5	1	0.6	1.33
7015DF	7015DT	74.9	34.9	82	—	108	110.5	1	0.6	1.38
7015BDF	7015BDT	99.7	59.7	82	—	108	110.5	1	0.6	1.38
7015CDF	7015CDT	45.5	5.5	82	—	108	110.5	1	0.6	1.38

2) B, C or no indication after the bearing number indicates nominal contact angle of 40°, 15° and 30° respectively.

[Remark] Standard cage types used for the above bearings are described earlier in this section.

Angular contact ball bearings (matched pair)

d (75) ~ (85) mm

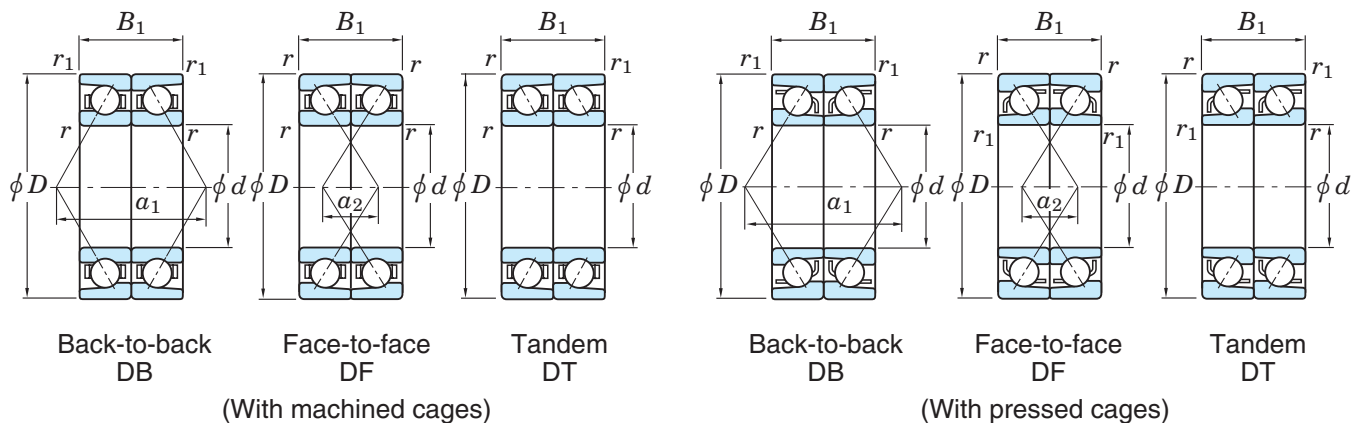

Boundary dimensions (mm)					Basic load ratings (kN)				Factor	Limiting speeds ¹⁾ (min ⁻¹)		Back-to-back DB
d	D	B_1	$r_{\min.}$	$r_{1\min.}$	With machined cages		With pressed cages			Grease lub.	Oil lub.	
75	130	50	1.5	1	129	130	134	139	—	4 600	5 800	7215DB
	130	50	1.5	1	116	119	122	127	—	3 500	4 600	7215BDB
	130	50	1.5	1	140	141	146	151	14.6	6 400	8 500	7215CDB
	160	74	2.1	1.1	208	194	221	212	—	4 000	5 000	7315DB
	160	74	2.1	1.1	191	178	202	195	—	3 000	4 000	7315BDB
	160	74	2.1	1.1	223	208	236	227	13.4	5 500	7 400	7315CDB
	190	90	3	1.1	278	282	—	—	—	2 500	3 600	7415DB
	190	90	3	1.1	257	261	—	—	—	2 200	3 300	7415BDB
80	110	32	1	0.6	48.4	63.2	—	—	16.5	7 000	9 300	7916CDB
	110	32	1	0.6	22.2	23.9	—	—	8.8	9 300	14 000	HAR916CDB
	125	44	1.1	0.6	40.1	38.5	—	—	8.4	8 200	13 000	HAR016CDB
	125	44	1.1	0.6	86.7	101	—	—	—	4 600	5 800	7016DB
	125	44	1.1	0.6	77.7	91.3	—	—	—	3 500	4 600	7016BDB
	125	44	1.1	0.6	95.3	111	—	—	15.7	6 400	8 500	7016CDB
	140	52	2	1	139	143	145	152	—	4 300	5 400	7216DB
	140	52	2	1	125	130	131	139	—	3 200	4 300	7216BDB
	140	52	2	1	151	155	157	165	14.7	5 900	7 900	7216CDB
	170	78	2.1	1.1	226	218	239	238	—	3 800	4 700	7316DB
	170	78	2.1	1.1	207	200	219	218	—	2 800	3 800	7316BDB
	170	78	2.1	1.1	242	233	256	255	13.5	5 200	6 900	7316CDB
	200	96	3	1.1	313	332	—	—	—	2 400	3 400	7416DB
	200	96	3	1.1	290	307	—	—	—	2 100	3 100	7416BDB
85	120	36	1.1	0.6	63.2	81.3	—	—	16.5	6 500	8 600	7917CDB
	120	36	1.1	0.6	26.6	28.4	—	—	8.7	8 200	13 000	HAR917CDB
	130	44	1.1	0.6	40.8	40.2	—	—	8.5	7 800	12 000	HAR017CDB
	130	44	1.1	0.6	88.6	107	—	—	—	4 400	5 500	7017DB
	130	44	1.1	0.6	79.3	96.7	—	—	—	3 300	4 400	7017BDB

[Notes] 1) Limiting speeds shown above are applicable to machined cage bearings. Limiting speeds of pressed cage bearings should be kept to under 80% of this value. For bearings with 15° contact angle, this figure is applied to the high precision bearings ranked higher than class 5, used with machined cages or molded cages.

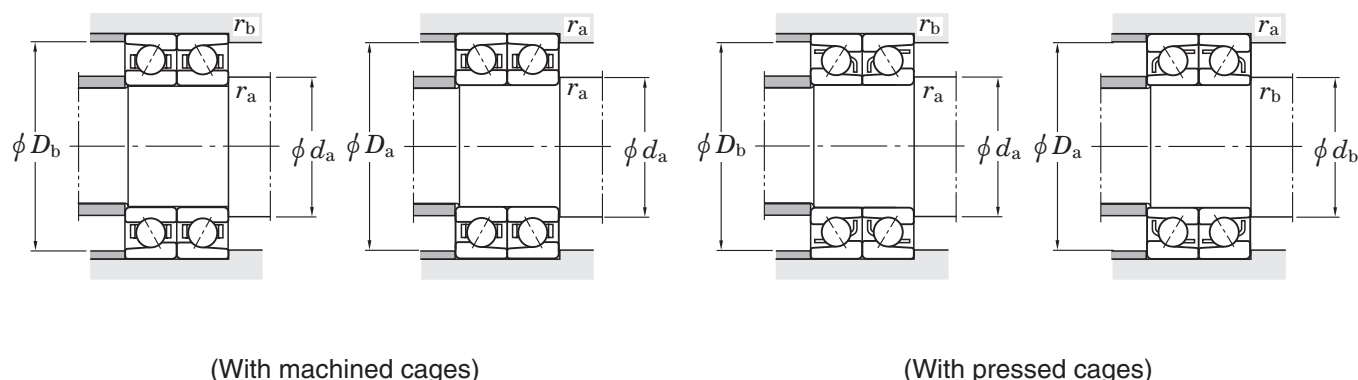

Bearing No. ²⁾		Load center spread (mm)		Mounting dimensions (mm)						(Refer.) Mass (kg)
				d_a min.	d_b min.	D_a max.	D_b max.	r_a max.	r_b max.	
Face-to-face DF	Tandem DT	a_1	a_2							
7215DF	7215DT	84.2	34.2	83.5	80.5	121.5	124.5	1.5	1	2.46
7215BDF	7215BDT	111.0	61.0	83.5	80.5	121.5	124.5	1.5	1	2.46
7215CDF	7215CDT	52.5	2.5	83.5	80.5	121.5	124.5	1.5	1	2.46
7315DF	7315DT	104.9	30.9	87	82	148	153	2	1	6.30
7315BDF	7315BDT	135.6	61.6	87	82	148	153	2	1	6.30
7315CDF	7315CDT	68.5	5.5	87	82	148	153	2	1	6.30
7415DF	7415DT	122.7	32.7	89	—	176	183	2.5	1	11.8
7415BDF	7415BDT	157.9	67.9	89	—	176	183	2.5	1	11.8
7916CDF	7916CDT	41.5	9.5	85.5	—	104.5	105.5	1	0.6	0.736
HAR916CDF	HAR916CDT	41.5	9.5	85.5	—	104.5	105.5	1	0.6	0.796
HAR016CDF	HAR016CDT	49.5	5.5	87	—	118	120.5	1	0.6	1.81
7016DF	7016DT	81.2	37.2	87	—	118	120.5	1	0.6	1.86
7016BDF	7016BDT	108.0	64.0	87	—	118	120.5	1	0.6	1.86
7016CDF	7016CDT	49.5	5.5	87	—	118	120.5	1	0.6	1.86
7216DF	7216DT	89.5	37.5	90	85.5	130	134.5	2	1	3.00
7216BDF	7216BDT	118.3	66.3	90	85.5	130	134.5	2	1	3.00
7216CDF	7216CDT	55.5	3.5	90	85.5	130	134.5	2	1	3.00
7316DF	7316DT	111.2	33.2	92	87	158	163	2	1	7.70
7316BDF	7316BDT	143.9	65.9	92	87	158	163	2	1	7.70
7316CDF	7316CDT	72.5	5.5	92	87	158	163	2	1	7.70
7416DF	7416DT	130.0	34.0	94	—	186	193	2.5	1	12.0
7416BDF	7416BDT	167.2	71.2	94	—	186	193	2.5	1	12.0
7917CDF	7917CDT	45.5	9.5	92	—	113	115.5	1	0.6	1.05
HAR917CDF	HAR917CDT	45.5	9.5	92	—	113	115.5	1	0.6	1.14
HAR017CDF	HAR017CDT	50.8	6.8	92	—	123	125.5	1	0.6	1.89
7017DF	7017DT	84.7	40.7	92	—	123	125.5	1	0.6	1.94
7017BDF	7017BDT	113.0	69.0	92	—	123	125.5	1	0.6	1.94

2) B, C or no indication after the bearing number indicates nominal contact angle of 40°, 15° and 30° respectively.

[Remark] Standard cage types used for the above bearings are described earlier in this section.

Angular contact ball bearings (matched pair)

d (85) ~ (95) mm

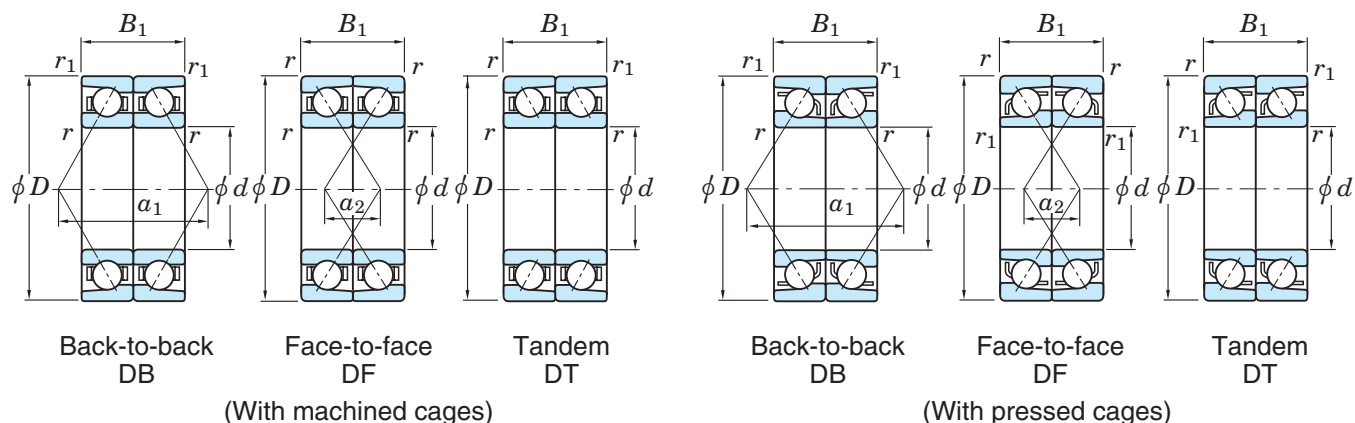

Boundary dimensions (mm)					Basic load ratings (kN)				Factor	Limiting speeds ¹⁾ (min ⁻¹)		Back-to-back DB
d	D	B_1	$r_{\min.}$	$r_{1\min.}$	With machined cages		With pressed cages			Grease lub.	Oil lub.	
85	130	44	1.1	0.6	97.6	117	—	—	15.9	6 000	8 000	7017CDB
	150	56	2	1	160	167	167	178	—	4 000	5 000	7217DB
	150	56	2	1	145	152	151	162	—	3 000	4 000	7217BDB
	150	56	2	1	174	181	182	193	14.7	5 500	7 400	7217CDB
	180	82	3	1.1	243	243	258	265	—	3 500	4 400	7317DB
	180	82	3	1.1	223	223	236	244	—	2 700	3 500	7317BDB
	180	82	3	1.1	261	261	277	284	13.5	4 900	6 500	7317CDB
	210	104	4	1.5	331	360	—	—	—	2 300	3 300	7417DB
	210	104	4	1.5	307	334	—	—	—	2 000	3 000	7417BDB
90	125	36	1.1	0.6	64.3	85.2	—	—	16.6	6 200	8 200	7918CDB
	125	36	1.1	0.6	27.3	30.2	—	—	8.8	7 800	12 000	HAR918CDB
	140	48	1.5	1	53.3	52.1	—	—	8.4	7 300	11 000	HAR018CDB
	140	48	1.5	1	106	127	—	—	—	4 100	5 100	7018DB
	140	48	1.5	1	94.9	114	—	—	—	3 100	4 100	7018BDB
	140	48	1.5	1	116	138	—	—	15.7	5 700	7 500	7018CDB
	160	60	2	1	183	193	191	206	—	3 800	4 700	7218DB
	160	60	2	1	166	176	173	188	—	2 800	3 800	7218BDB
	160	60	2	1	199	209	208	223	14.6	5 200	6 900	7218CDB
	190	86	3	1.1	261	270	277	294	—	3 300	4 200	7318DB
	190	86	3	1.1	240	248	254	270	—	2 500	3 300	7318BDB
	190	86	3	1.1	281	289	297	315	13.5	4 600	6 100	7318CDB
	225	108	4	1.5	351	393	—	—	—	2 100	3 100	7418DB
225	108	4	1.5	325	364	—	—	—	1 800	2 800	7418BDB	
95	130	36	1.1	0.6	65.3	88.3	—	—	16.5	5 900	7 900	7919CDB
	130	36	1.1	0.6	28.1	32.1	—	—	8.8	7 400	11 000	HAR919CDB
	145	48	1.5	1	54.3	54.4	—	—	8.5	7 000	11 000	HAR019CDB
	145	48	1.5	1	108	134	—	—	—	3 900	4 800	7019DB

[Notes] 1) Limiting speeds shown above are applicable to machined cage bearings. Limiting speeds of pressed cage bearings should be kept to under 80% of this value. For bearings with 15° contact angle, this figure is applied to the high precision bearings ranked higher than class 5, used with machined cages or molded cages.

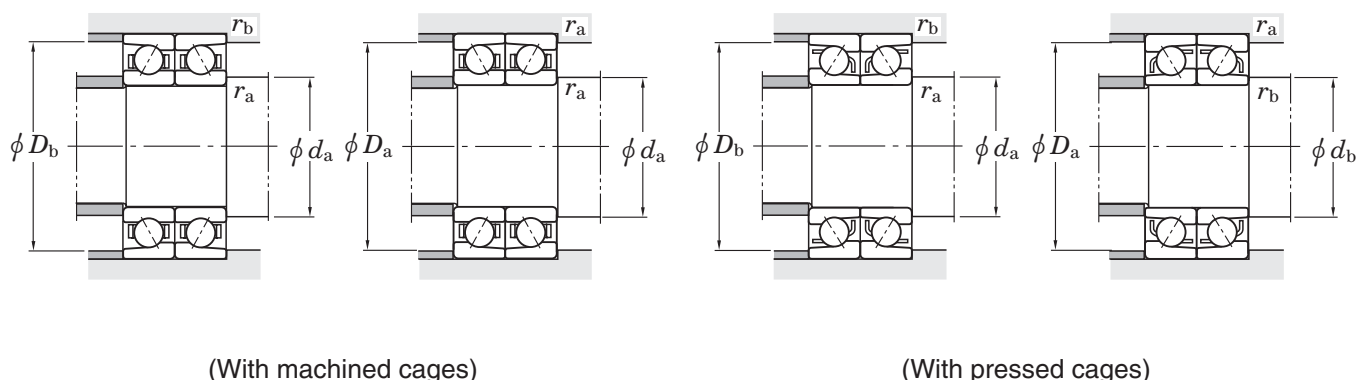

Bearing No. ²⁾		Load center spread (mm)		Mounting dimensions (mm)						(Refer.) Mass (kg)
Face-to-face DF	Tandem DT	a_1	a_2	d_a	d_b	D_a	D_b	r_a	r_b	
				min.	min.	max.	max.	max.	max.	
7017CDF	7017CDT	51.1	7.1	92	—	123	125.5	1	0.6	1.94
7217DF	7217DT	95.9	39.9	95	90.5	140	144.5	2	1	3.74
7217BDF	7217BDT	126.6	70.6	95	90.5	140	144.5	2	1	3.74
7217CDF	7217CDT	59.5	3.5	95	90.5	140	144.5	2	1	3.74
7317DF	7317DT	117.5	35.5	99	92	166	173	2.5	1	9.06
7317BDF	7317BDT	152.2	70.2	99	92	166	173	2.5	1	9.06
7317CDF	7317CDT	76.5	5.5	99	92	166	173	2.5	1	9.06
7417DF	7417DT	137.5	33.5	103	—	192	201.5	3	1.5	17.1
7417BDF	7417BDT	176.2	72.2	103	—	192	201.5	3	1.5	17.1
7918CDF	7918CDT	46.8	10.8	97	—	118	120.5	1	0.6	1.10
HAR918CDF	HAR918CDT	46.8	10.8	97	—	118	120.5	1	0.6	1.20
HAR018CDF	HAR018CDT	54.8	6.8	98.5	—	131.5	134.5	1.5	1	2.43
7018DF	7018DT	90.4	42.4	98.5	—	131.5	134.5	1.5	1	2.52
7018BDF	7018BDT	120.5	72.5	98.5	—	131.5	134.5	1.5	1	2.52
7018CDF	7018CDT	54.8	6.8	98.5	—	131.5	134.5	1.5	1	2.52
7218DF	7218DT	102.2	42.2	100	95.5	150	154.5	2	1	4.60
7218BDF	7218BDT	134.9	74.9	100	95.5	150	154.5	2	1	4.60
7218CDF	7218CDT	63.5	3.5	100	95.5	150	154.5	2	1	4.60
7318DF	7318DT	123.9	37.9	104	97	176	183	2.5	1	10.6
7318BDF	7318BDT	160.5	74.5	104	97	176	183	2.5	1	10.6
7318CDF	7318CDT	80.5	5.5	104	97	176	183	2.5	1	10.6
7418DF	7418DT	145.0	37.0	108	—	207	216.5	3	1.5	22.8
7418BDF	7418BDT	186.2	78.2	108	—	207	216.5	3	1.5	22.8
7919CDF	7919CDT	48.1	12.1	102	—	123	125.5	1	0.6	1.15
HAR919CDF	HAR919CDT	48.1	12.1	102	—	123	125.5	1	0.6	1.25
HAR019CDF	HAR019CDT	56.2	8.2	103.5	—	136.5	139.5	1.5	1	2.56
7019DF	7019DT	94.5	46.5	103.5	—	136.5	139.5	1.5	1	2.64

2) B, C or no indication after the bearing number indicates nominal contact angle of 40°, 15° and 30° respectively.

[Remark] Standard cage types used for the above bearings are described earlier in this section.

Angular contact ball bearings (matched pair)

d (95) ~ (105) mm

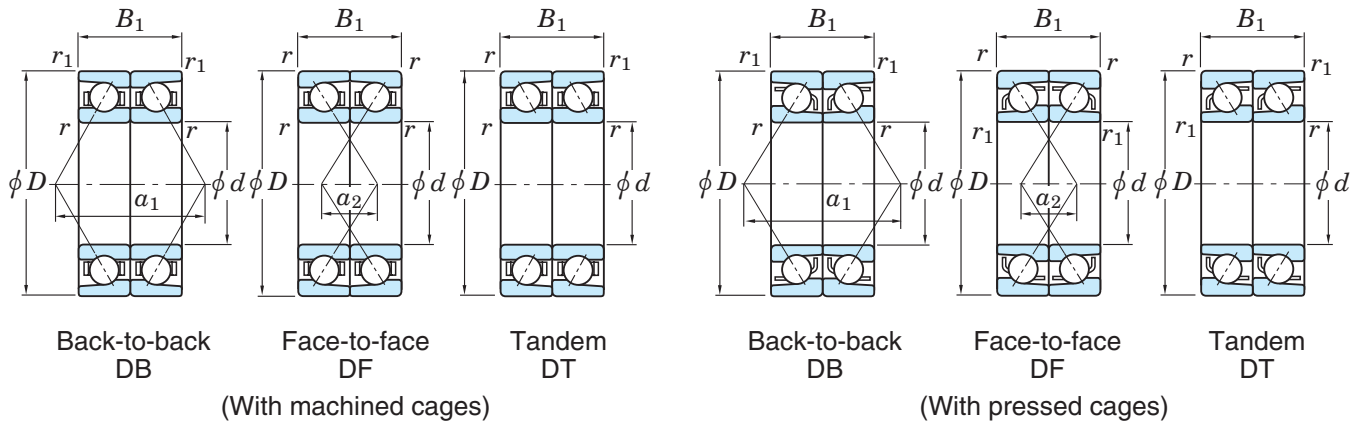

Boundary dimensions (mm)					Basic load ratings (kN)				Factor	Limiting speeds ¹⁾ (min ⁻¹)		Back-to-back DB
d	D	B_1	$r_{\min.}$	$r_{1\min.}$	With machined cages		With pressed cages			Grease lub.	Oil lub.	
95	145	48	1.5	1	96.8	121	—	—	—	2 900	3 900	7019BDB
	145	48	1.5	1	119	147	—	—	15.9	5 300	7 100	7019CDB
	170	64	2.1	1.1	198	207	208	221	—	3 500	4 400	7219DB
	170	64	2.1	1.1	180	188	188	201	—	2 700	3 500	7219BDB
	170	64	2.1	1.1	216	224	226	240	14.6	4 900	6 500	7219CDB
	200	90	3	1.1	280	298	297	325	—	3 200	4 000	7319DB
	200	90	3	1.1	256	273	272	298	—	2 400	3 200	7319BDB
	200	90	3	1.1	300	319	318	348	13.5	4 400	5 800	7319CDB
100	140	40	1.1	0.6	90.2	117	—	—	16.3	5 500	7 400	7920CDB
	140	40	1.1	0.6	39.2	43.5	—	—	8.7	7 000	11 000	HAR920CDB
	150	48	1.5	1	55.2	56.7	—	—	8.5	6 700	10 000	HAR020CDB
	150	48	1.5	1	111	141	—	—	—	3 800	4 700	7020DB
	150	48	1.5	1	99.4	127	—	—	—	2 800	3 800	7020BDB
	150	48	1.5	1	122	154	—	—	16.0	5 200	6 900	7020CDB
	180	68	2.1	1.1	223	235	233	252	—	3 300	4 100	7220DB
	180	68	2.1	1.1	202	214	211	229	—	2 500	3 300	7220BDB
	180	68	2.1	1.1	242	254	254	273	14.6	4 600	6 100	7220CDB
	215	94	3	1.1	298	323	337	387	—	2 900	3 600	7320DB
	215	94	3	1.1	274	297	309	356	—	2 200	2 900	7320BDB
	215	94	3	1.1	320	346	361	415	13.4	4 000	5 300	7320CDB
105	145	40	1.1	0.6	92.1	123	—	—	16.4	5 300	7 100	7921CDB
	145	40	1.1	0.6	40.4	46.2	—	—	8.7	6 700	10 000	HAR921CDB
	160	52	2	1	62.6	65.1	—	—	8.5	6 300	9 800	HAR021CDB
	160	52	2	1	130	164	—	—	—	3 500	4 400	7021DB
	160	52	2	1	116	148	—	—	—	2 600	3 500	7021BDB
	160	52	2	1	143	179	—	—	15.9	4 800	6 400	7021CDB
	190	72	2.1	1.1	243	265	—	—	—	3 100	3 900	7221DB

[Notes] 1) Limiting speeds shown above are applicable to machined cage bearings. Limiting speeds of pressed cage bearings should be kept to under 80% of this value. For bearings with 15° contact angle, this figure is applied to the high precision bearings ranked higher than class 5, used with machined cages or molded cages.

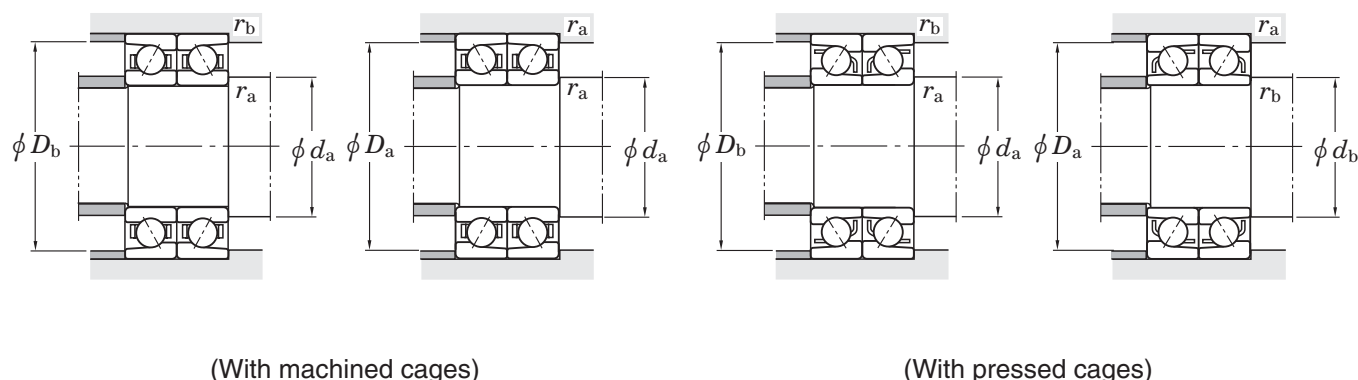

Bearing No. ²⁾		Load center spread (mm)		Mounting dimensions (mm)						(Refer.) Mass (kg)
Face-to-face DF	Tandem DT	a_1	a_2	d_a	d_b	D_a	D_b	r_a	r_b	
				min.	min.	max.	max.	max.	max.	
7019BDF	7019BDT	126.4	78.4	103.5	—	136.5	139.5	1.5	1	2.64
7019CDF	7019CDT	56.7	8.7	103.5	—	136.5	139.5	1.5	1	2.64
7219DF	7219DT	108.5	44.5	107	102	158	163	2	1	5.56
7219BDF	7219BDT	143.2	79.2	107	102	158	163	2	1	5.56
7219CDF	7219CDT	67.5	3.5	107	102	158	163	2	1	5.56
7319DF	7319DT	130.2	40.2	109	102	186	193	2.5	1	12.2
7319BDF	7319BDT	168.8	78.8	109	102	186	193	2.5	1	12.2
7319CDF	7319CDT	84.5	5.5	109	102	186	193	2.5	1	12.2
7920CDF	7920CDT	52.1	12.1	107	—	133	135.5	1	0.6	1.55
HAR920CDF	HAR920CDT	52.2	12.2	107	—	133	135.5	1	0.6	1.68
HAR020CDF	HAR020CDT	57.5	9.5	108.5	—	141.5	144.5	1.5	1	2.64
7020DF	7020DT	96.2	48.2	108.5	—	141.5	144.5	1.5	1	2.74
7020BDF	7020BDT	128.9	80.9	108.5	—	141.5	144.5	1.5	1	2.74
7020CDF	7020CDT	57.5	9.5	108.5	—	141.5	144.5	1.5	1	2.74
7220DF	7220DT	115.4	47.4	112	—	168	173	2	1	6.64
7220BDF	7220BDT	152.3	84.3	112	—	168	173	2	1	6.64
7220CDF	7220CDT	71.8	3.8	112	107	168	173	2	1	6.64
7320DF	7320DT	138.8	44.8	114	—	201	208	2.5	1	15.1
7320BDF	7320BDT	180.4	86.4	114	—	201	208	2.5	1	15.1
7320CDF	7320CDT	89.6	4.4	114	107	201	208	2.5	1	15.1
7921CDF	7921CDT	53.5	13.5	112	—	138	140.5	1	0.6	1.62
HAR921CDF	HAR921CDT	53.5	13.5	112	—	138	140.5	1	0.6	1.75
HAR021CDF	HAR021CDT	61.5	9.5	115	—	150	154.5	2	1	3.37
7021DF	7021DT	103.7	51.7	115	—	150	154.5	2	1	3.46
7021BDF	7021BDT	137.2	85.2	115	—	150	154.5	2	1	3.46
7021CDF	7021CDT	62.0	10.0	115	—	150	154.5	2	1	3.46
7221DF	7221DT	122.1	50.1	117	—	178	183	2	1	7.90

2) B, C or no indication after the bearing number indicates nominal contact angle of 40°, 15° and 30° respectively.

[Remark] Standard cage types used for the above bearings are described earlier in this section.

Angular contact ball bearings (matched pair)

d (105) ~ (120) mm

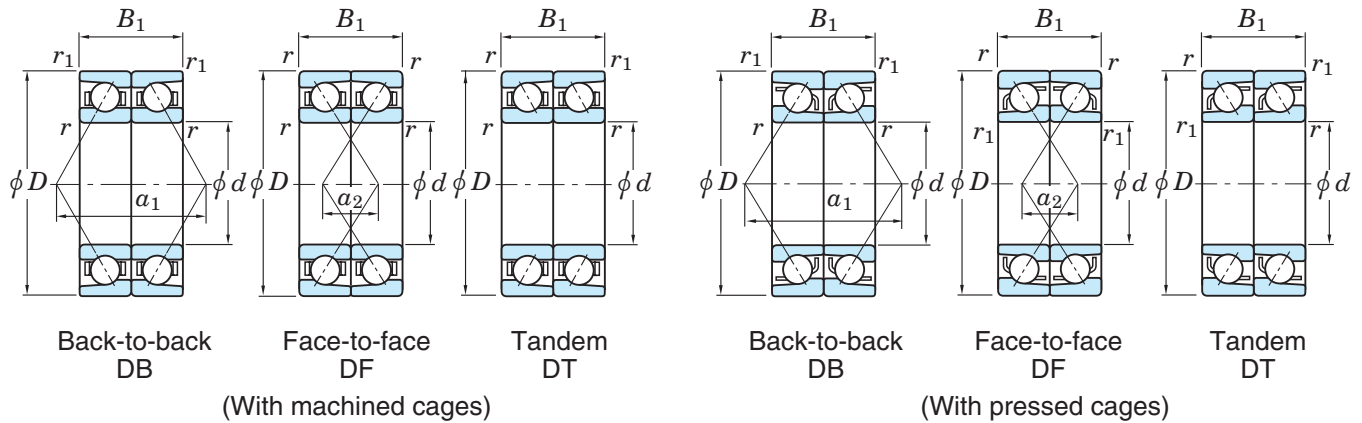

Boundary dimensions (mm)					Basic load ratings (kN)				Factor	Limiting speeds ¹⁾ (min ⁻¹)		Back-to-back DB
d	D	B_1	$r_{\min.}$	$r_{1\min.}$	With machined cages		With pressed cages			Grease lub.	Oil lub.	
105	190	72	2.1	1.1	220	241	—	—	—	2 300	3 100	7221BDB
	190	72	2.1	1.1	264	287	—	—	14.6	4 300	5 700	7221CDB
	225	98	3	1.1	337	386	—	—	—	2 800	3 500	7321DB
	225	98	3	1.1	310	355	—	—	—	2 100	2 800	7321BDB
	225	98	3	1.1	362	413	—	—	13.4	3 900	5 100	7321CDB
110	150	40	1.1	0.6	93.8	129	—	—	16.5	5 100	6 800	7922CDB
	150	40	1.1	0.6	40.8	47.7	—	—	8.7	6 400	9 900	HAR922CDB
	170	56	2	1	70.5	73.9	—	—	8.5	6 000	9 200	HAR022CDB
	170	56	2	1	149	186	—	—	—	3 300	4 200	7022DB
	170	56	2	1	134	167	—	—	—	2 500	3 300	7022BDB
	170	56	2	1	164	203	—	—	15.7	4 600	6 100	7022CDB
	200	76	2.1	1.1	263	297	—	—	—	3 000	3 700	7222DB
	200	76	2.1	1.1	238	270	—	—	—	2 200	3 000	7222BDB
	200	76	2.1	1.1	286	321	—	—	14.5	4 100	5 400	7222CDB
	240	100	3	1.1	377	452	—	—	—	2 600	3 200	7322DB
	240	100	3	1.1	346	416	—	—	—	1 900	2 600	7322BDB
	240	100	3	1.1	404	484	—	—	13.4	3 500	4 700	7322CDB
120	165	44	1.1	0.6	117	162	—	—	16.5	4 700	6 200	7924CDB
	165	44	1.1	0.6	47.7	56.8	—	—	8.8	5 900	9 100	HAR924CDB
	180	56	2	1	72.9	79.9	—	—	8.5	5 600	8 600	HAR024CDB
	180	56	2	1	157	206	—	—	—	3 100	3 900	7024DB
	180	56	2	1	140	186	—	—	—	2 300	3 100	7024BDB
	180	56	2	1	173	226	—	—	16.0	4 300	5 700	7024CDB
	215	80	2.1	1.1	283	332	—	—	—	2 700	3 400	7224DB
	215	80	2.1	1.1	257	302	—	—	—	2 100	2 800	7224BDB
	215	80	2.1	1.1	308	359	—	—	14.6	3 800	5 000	7224CDB
	260	110	3	1.1	400	504	—	—	—	2 400	3 000	7324DB

[Notes] 1) Limiting speeds shown above are applicable to machined cage bearings. Limiting speeds of pressed cage bearings should be kept to under 80% of this value. For bearings with 15° contact angle, this figure is applied to the high precision bearings ranked higher than class 5, used with machined cages or molded cages.

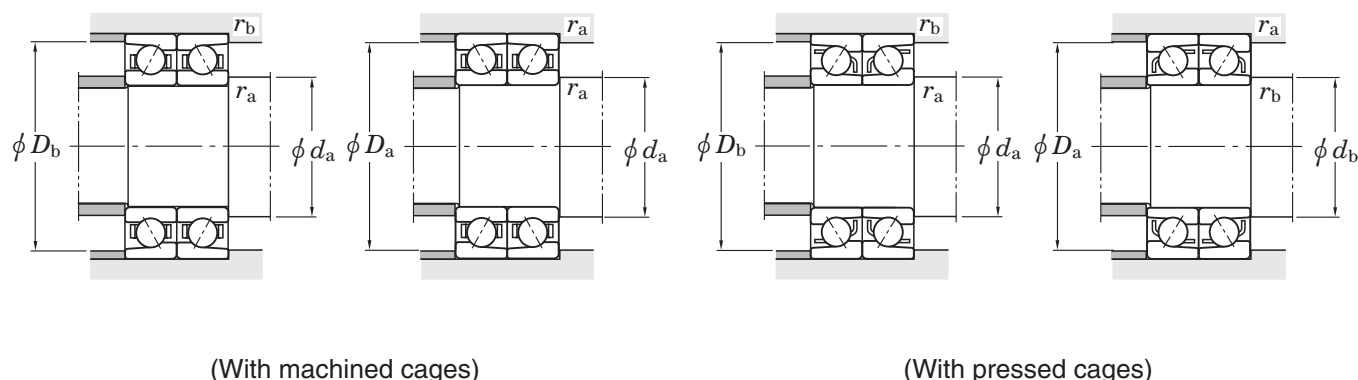

Bearing No. ²⁾		Load center spread (mm)		Mounting dimensions (mm)						(Refer.) Mass (kg)
Face-to-face DF	Tandem DT	a_1	a_2	d_a min.	d_b min.	D_a max.	D_b max.	r_a max.	r_b max.	
7221BDF	7221BDT	161.0	89.0	117	—	178	183	2	1	7.90
7221CDF	7221CDT	75.9	3.9	117	—	178	183	2	1	7.90
7321DF	7321DT	144.3	46.3	119	—	211	218	2.5	1	17.2
7321BDF	7321BDT	187.5	89.5	119	—	211	218	2.5	1	17.2
7321CDF	7321CDT	93.2	4.8	119	—	211	218	2.5	1	17.2
7922CDF	7922CDT	54.8	14.8	117	—	143	145.5	1	0.6	1.68
HAR922CDF	HAR922CDT	54.8	14.8	117	—	143	145.5	1	0.6	1.82
HAR022CDF	HAR022CDT	65.5	9.5	120	—	160	164.5	2	1	4.22
7022DF	7022DT	108.9	52.9	120	—	160	164.5	2	1	4.28
7022BDF	7022BDT	145.5	89.5	120	—	160	164.5	2	1	4.28
7022CDF	7022CDT	65.5	9.5	120	—	160	164.5	2	1	4.28
7222DF	7222DT	128.7	52.7	122	—	188	193	2	1	9.30
7222BDF	7222BDT	169.7	93.7	122	—	188	193	2	1	9.30
7222CDF	7222CDT	80.1	4.1	122	—	188	193	2	1	9.30
7322DF	7322DT	152.7	52.7	124	—	226	233	2.5	1	20.2
7322BDF	7322BDT	199.3	99.3	124	—	226	233	2.5	1	20.2
7322CDF	7322CDT	97.7	2.3	124	—	226	233	2.5	1	20.2
7924CDF	7924CDT	60.2	16.2	127	—	158	160.5	1	0.6	2.30
HAR924CDF	HAR924CDT	60.2	16.2	127	—	158	160.5	1	0.6	2.49
HAR024CDF	HAR024CDT	68.2	12.2	130	—	170	174.5	2	1	4.52
7024DF	7024DT	114.6	58.6	130	—	170	174.5	2	1	4.54
7024BDF	7024BDT	153.9	97.9	130	—	170	174.5	2	1	4.54
7024CDF	7024CDT	68.2	12.2	130	—	170	174.5	2	1	4.54
7224DF	7224DT	137.0	57.0	132	—	203	208	2	1	11.0
7224BDF	7224BDT	180.5	100.5	132	—	203	208	2	1	11.0
7224CDF	7224CDT	85.0	5.0	132	—	203	208	2	1	11.0
7324DF	7324DT	164.7	54.7	134	—	246	253	2.5	1	25.2

2) B, C or no indication after the bearing number indicates nominal contact angle of 40°, 15° and 30° respectively.

[Remark] Standard cage types used for the above bearings are described earlier in this section.

Angular contact ball bearings (matched pair)

d (120) ~ (150) mm

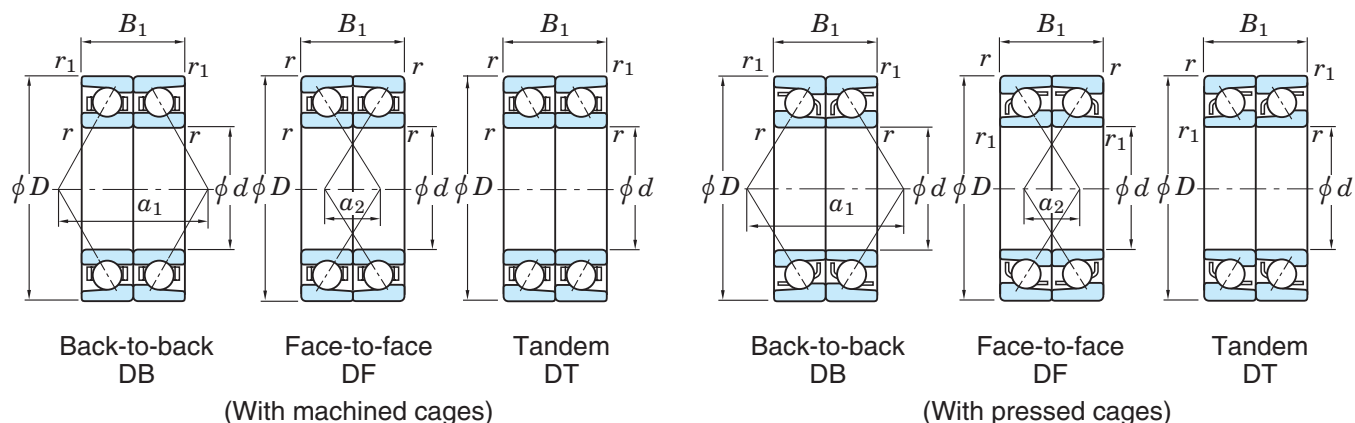

Boundary dimensions (mm)					Basic load ratings (kN)				Factor	Limiting speeds ¹⁾ (min ⁻¹)		Back-to-back DB
d	D	B_1	$r_{\min.}$	$r_{1\min.}$	With machined cages		With pressed cages			Grease lub.	Oil lub.	
120	260	110	3	1.1	366	462	—	—	—	1 800	2 400	7324BDB
	260	110	3	1.1	431	542	—	—	13.7	3 300	4 400	7324CDB
130	180	48	1.5	1	142	200	—	—	16.4	4 300	5 700	7926CDB
	180	48	1.5	1	57.0	70.3	—	—	8.8	5 400	8 300	HAR926CDB
	200	66	2	1	91.5	96.7	—	—	8.5	5 100	7 800	HAR026CDB
	200	66	2	1	191	251	—	—	—	2 800	3 500	7026DB
	200	66	2	1	171	226	—	—	—	2 100	2 800	7026BDB
	200	66	2	1	210	274	—	—	15.9	3 900	5 100	7026CDB
	230	80	3	1.1	318	395	—	—	—	2 500	3 200	7226DB
	230	80	3	1.1	288	360	—	—	—	1 900	2 500	7226BDB
	230	80	3	1.1	346	428	—	—	14.7	3 500	4 700	7226CDB
	280	116	4	1.5	489	659	—	—	—	2 200	2 700	7326DB
	280	116	4	1.5	406	536	—	—	—	1 600	2 200	7326BDB
	280	116	4	1.5	478	629	—	—	13.7	3 000	4 000	7326CDB
	140	190	48	1.5	1	143	210	—	—	16.6	4 000	5 400
190		48	1.5	1	57.2	72.4	—	—	8.8	5 100	7 800	HAR928CDB
210		66	2	1	99.6	112	—	—	8.5	4 800	7 400	HAR028CDB
210		66	2	1	194	265	—	—	—	2 600	3 300	7028DB
210		66	2	1	174	237	—	—	—	2 000	2 600	7028BDB
210		66	2	1	214	290	—	—	16.0	3 600	4 800	7028CDB
250		84	3	1.1	355	468	—	—	—	2 300	2 900	7228DB
250		84	3	1.1	320	426	—	—	—	1 700	2 300	7228BDB
250		84	3	1.1	386	508	—	—	14.8	3 200	4 300	7228CDB
300		124	4	1.5	535	748	—	—	—	2 000	2 500	7328DB
300		124	4	1.5	491	688	—	—	—	1 500	2 000	7328BDB
300		124	4	1.5	573	802	—	—	13.4	2 800	3 700	7328CDB
150	210	56	2	1	187	263	—	—	16.3	3 700	4 900	7930CDB

[Notes] 1) Limiting speeds shown above are applicable to machined cage bearings. Limiting speeds of pressed cage bearings should be kept to under 80% of this value. For bearings with 15° contact angle, this figure is applied to the high precision bearings ranked higher than class 5, used with machined cages or molded cages.

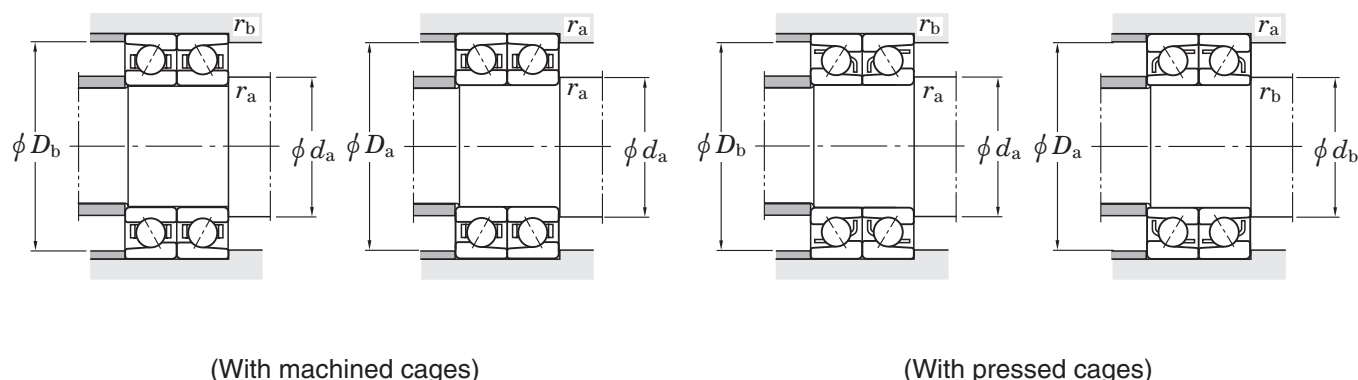

Bearing No. ²⁾		Load center spread (mm)		Mounting dimensions (mm)						(Refer.) Mass (kg)
Face-to-face DF	Tandem DT	a_1	a_2	d_a min.	d_b min.	D_a max.	D_b max.	r_a max.	r_b max.	
7324BDF	7324BDT	214.4	104.4	134	—	246	253	2.5	1	25.2
7324CDF	7324CDT	105.9	4.1	134	—	246	253	2.5	1	25.2
7926CDF	7926CDT	65.5	17.5	138.5	—	171.5	174.5	1.5	1	3.00
HAR926CDF	HAR926CDT	65.5	17.5	138.5	—	171.5	174.5	1.5	1	3.32
HAR026CDF	HAR026CDT	77.2	11.2	140	—	190	194.5	2	1	6.77
7026DF	7026DT	128.3	62.3	140	—	190	194.5	2	1	6.86
7026BDF	7026BDT	171.5	105.5	140	—	190	194.5	2	1	6.86
7026CDF	7026CDT	77.2	11.2	140	—	190	194.5	2	1	6.86
7226DF	7226DT	143.9	63.9	144	—	216	223	2.5	1	12.4
7226BDF	7226BDT	191.0	111.0	144	—	216	223	2.5	1	12.4
7226CDF	7226CDT	88.2	8.2	144	—	216	223	2.5	1	12.4
7326DF	7326DT	177.5	61.5	148	—	262	271.5	3	1.5	30.8
7326BDF	7326BDT	230.0	114.0	148	—	262	271.5	3	1.5	30.8
7326CDF	7326CDT	112.9	3.1	148	—	262	271.5	3	1.5	30.8
7928CDF	7928CDT	68.2	20.2	148.5	—	181.5	184.5	1.5	1	3.18
HAR928CDF	HAR928CDT	68.2	20.2	148.5	—	181.5	184.5	1.5	1	3.52
HAR028CDF	HAR028CDT	79.9	13.9	150	—	200	204.5	2	1	7.24
7028DF	7028DT	134.1	68.1	150	—	200	204.5	2	1	7.28
7028BDF	7028BDT	179.8	113.8	150	—	200	204.5	2	1	7.28
7028CDF	7028CDT	79.9	13.9	150	—	200	204.5	2	1	7.28
7228DF	7228DT	154.6	70.6	154	—	236	243	2.5	1	15.5
7228BDF	7228BDT	205.6	121.6	154	—	236	243	2.5	1	15.5
7228CDF	7228CDT	94.2	10.2	154	—	236	243	2.5	1	15.5
7328DF	7328DT	189.0	65.0	158	—	282	291.5	3	1.5	37.6
7328BDF	7328BDT	246.6	122.6	158	—	282	291.5	3	1.5	37.6
7328CDF	7328CDT	120.9	3.1	158	—	282	291.5	3	1.5	37.6
7930CDF	7930CDT	76.2	20.2	160	—	200	204.5	2	1	4.94

2) B, C or no indication after the bearing number indicates nominal contact angle of 40°, 15° and 30° respectively.

[Remark] Standard cage types used for the above bearings are described earlier in this section.

Angular contact ball bearings (matched pair)

d (150) ~ (170) mm

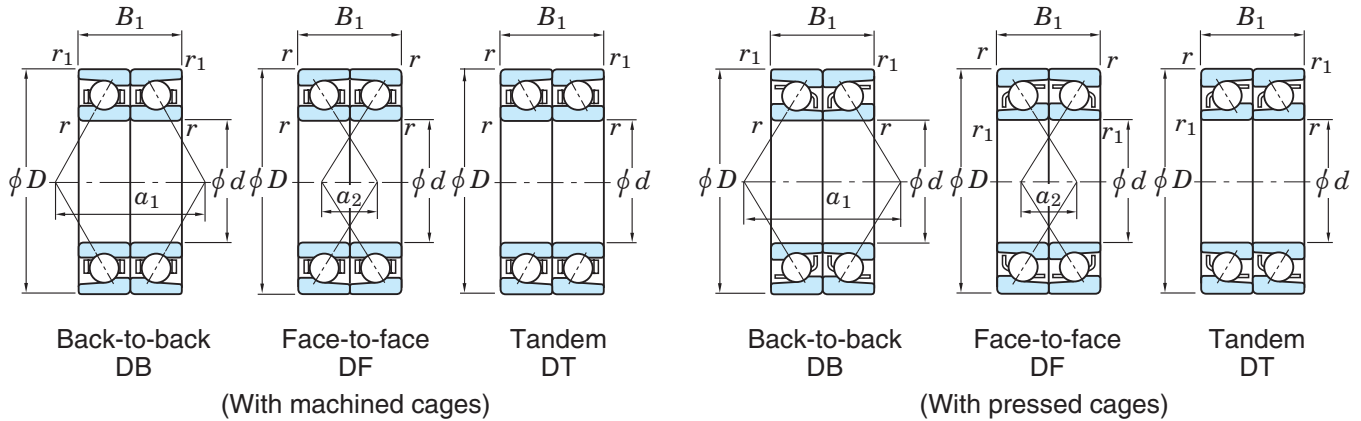

Boundary dimensions (mm)					Basic load ratings (kN)				Factor	Limiting speeds ¹⁾ (min ⁻¹)		Back-to-back DB
d	D	B_1	$r_{\min.}$	$r_{1\min.}$	With machined cages		With pressed cages			Grease lub.	Oil lub.	
150	210	56	2	1	79.5	97.7	—	—	8.7	4 600	7 200	HAR930CDB
	225	70	2	1	117	132	—	—	8.5	4 200	6 500	HAR030CDB
	225	70	2.1	1.1	222	308	—	—	—	2 400	3 000	7030DB
	225	70	2.1	1.1	199	275	—	—	—	1 800	2 400	7030BDB
	225	70	2.1	1.1	245	337	—	—	16.1	3 300	4 400	7030CDB
	270	90	3	1.1	403	560	—	—	—	2 100	2 700	7230DB
	270	90	3	1.1	365	509	—	—	—	1 600	2 100	7230BDB
	270	90	3	1.1	439	607	—	—	14.7	2 900	3 900	7230CDB
	320	130	4	1.5	565	829	—	—	—	1 900	2 300	7330DB
	320	130	4	1.5	516	760	—	—	—	1 400	1 900	7330BDB
	320	130	4	1.5	607	891	—	—	13.7	2 600	3 400	7330CDB
160	220	56	2	1	196	289	—	—	16.5	3 500	4 700	7932CDB
	220	56	2	1	81.5	104	—	—	8.8	4 200	6 400	HAR932CDB
	240	76	2.1	1.1	127	145	—	—	8.5	4 000	6 100	HAR032CDB
	240	76	2.1	1.1	252	353	—	—	—	2 300	2 800	7032DB
	240	76	2.1	1.1	225	316	—	—	—	1 700	2 300	7032BDB
	240	76	2.1	1.1	278	386	—	—	16.0	3 100	4 100	7032CDB
	290	96	3	1.1	374	525	—	—	—	2 000	2 500	7232DB
	290	96	3	1.1	386	557	—	—	—	1 500	2 000	7232BDB
	290	96	3	1.1	465	665	—	—	15.2	2 700	3 600	7232CDB
	340	136	4	1.5	592	909	—	—	—	1 700	2 200	7332DB
	340	136	4	1.5	540	831	—	—	—	1 300	1 700	7332BDB
	340	136	4	1.5	640	980	—	—	14.0	2 400	3 200	7332CDB
170	230	56	2	1	199	302	—	—	16.6	3 100	4 100	7934CDB
	230	56	2	1	83.4	110	—	—	8.8	4 000	6 100	HAR934CDB
	260	84	2.1	1.1	149	173	—	—	8.5	3 700	5 700	HAR034CDB
	260	84	2.1	1.1	302	429	—	—	—	2 100	2 600	7034DB

[Notes] 1) Limiting speeds shown above are applicable to machined cage bearings. Limiting speeds of pressed cage bearings should be kept to under 80% of this value. For bearings with 15° contact angle, this figure is applied to the high precision bearings ranked higher than class 5, used with machined cages or molded cages.

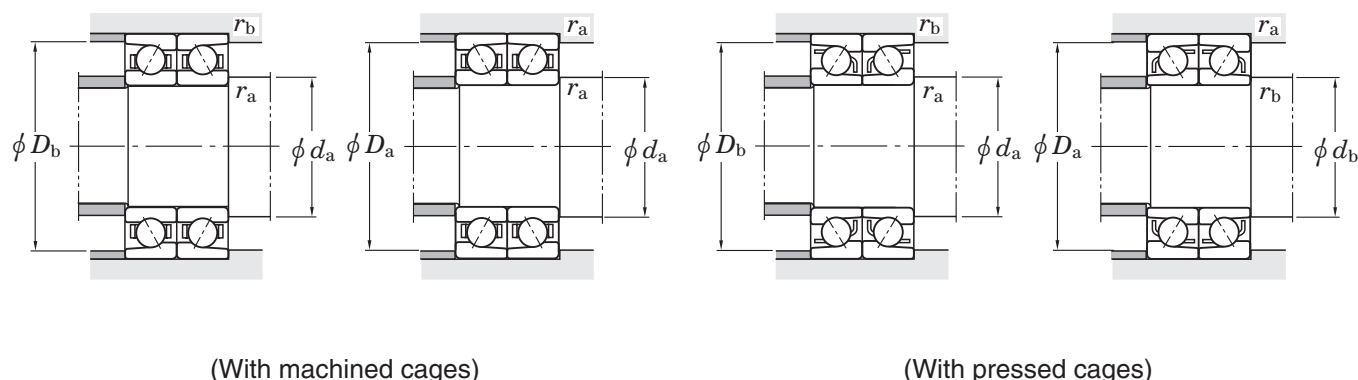

(With machined cages)

(With pressed cages)

Bearing No. ²⁾		Load center spread (mm)		Mounting dimensions (mm)						(Refer.) Mass (kg)
Face-to-face DF	Tandem DT	a_1	a_2	d_a min.	d_b min.	D_a max.	D_b max.	r_a max.	r_b max.	
HAR930CDF	HAR930CDT	76.2	20.2	160	—	200	204.5	2	1	5.36
HAR030CDF	HAR030CDT	85.2	15.2	160	—	215	219.5	2	1	8.72
7030DF	7030DT	144.2	74.2	162	—	213	218	2	1	8.86
7030BDF	7030BDT	192.3	122.3	162	—	213	218	2	1	8.86
7030CDF	7030CDT	85.6	15.6	162	—	213	218	2	1	8.86
7230DF	7230DT	166.3	76.3	164	—	256	263	2.5	1	19.5
7230BDF	7230BDT	221.2	131.2	164	—	256	263	2.5	1	19.5
7230CDF	7230CDT	101.3	11.3	164	—	256	263	2.5	1	19.5
7330DF	7330DT	200.7	70.7	168	—	302	311.5	3	1.5	44.8
7330BDF	7330BDT	262.2	132.2	168	—	302	311.5	3	1.5	44.8
7330CDF	7330CDT	128.0	2.0	168	—	302	311.5	3	1.5	44.8
7932CDF	7932CDT	78.9	22.9	170	—	210	214.5	2	1	5.20
HAR932CDF	HAR932CDT	78.9	22.9	170	—	210	214.5	2	1	5.66
HAR032CDF	HAR032CDT	91.6	15.6	172	—	228	233	2	1	10.8
7032DF	7032DT	153.5	77.5	172	—	228	233	2	1	10.9
7032BDF	7032BDT	205.8	129.8	172	—	228	233	2	1	10.9
7032CDF	7032CDT	91.6	15.6	172	—	228	233	2	1	10.9
7232DF	7232DT	177.9	81.9	174	—	276	283	2.5	1	24.2
7232BDF	7232BDT	236.8	140.8	174	—	276	283	2.5	1	24.2
7232CDF	7232CDT	108.3	12.3	174	—	276	283	2.5	1	24.2
7332DF	7332DT	212.3	76.3	178	—	322	331.5	3	1.5	52.8
7332BDF	7332BDT	277.8	141.8	178	—	322	331.5	3	1.5	52.8
7332CDF	7332CDT	135.0	1.0	168.5	—	322	331.5	3	1.5	52.8
7934CDF	7934CDT	81.6	25.6	180	—	220	224.5	2	1	6.42
HAR934CDF	HAR934CDT	81.6	25.6	180	—	220	224.5	2	1	5.94
HAR034CDF	HAR034CDT	99.6	15.6	182	—	248	253	2	1	14.6
7034DF	7034DT	166.2	82.2	182	—	248	253	2	1	15.2

2) B, C or no indication after the bearing number indicates nominal contact angle of 40°, 15° and 30° respectively.

[Remark] Standard cage types used for the above bearings are described earlier in this section.

Angular contact ball bearings (matched pair)

d (170) ~ 190 mm

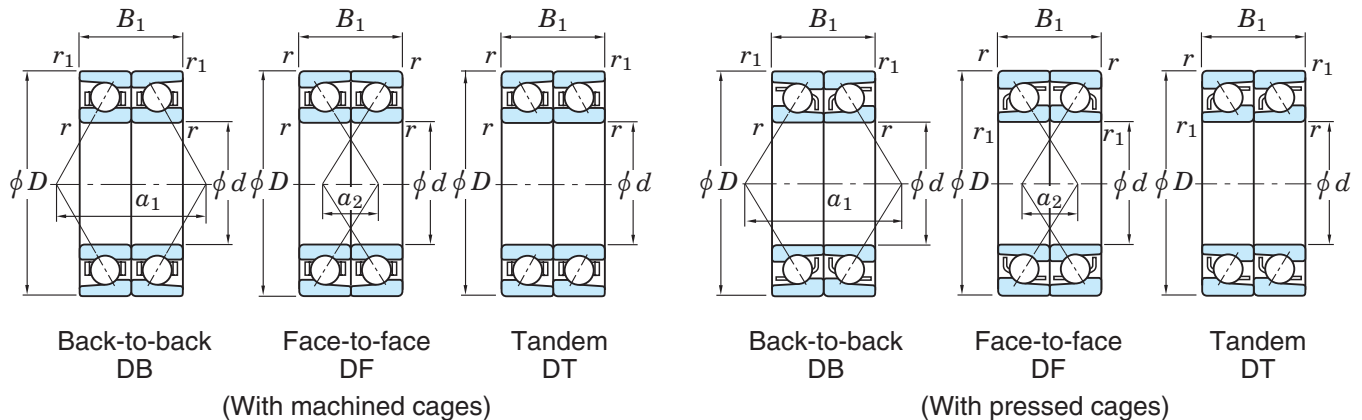

Boundary dimensions (mm)					Basic load ratings (kN)				Factor	Limiting speeds ¹⁾ (min ⁻¹)		Back-to-back DB
d	D	B_1	$r_{\min.}$	$r_{1\min.}$	With machined cages		With pressed cages			Grease lub.	Oil lub.	
					C_r	C_{Or}	C_r	C_{Or}	f_0			
170	260	84	2.1	1.1	270	386	—	—	—	1 600	2 100	7034BDB
	260	84	2.1	1.1	332	469	—	—	15.9	2 900	3 800	7034CDB
	310	104	4	1.5	441	661	—	—	—	1 800	2 300	7234DB
	310	104	4	1.5	398	600	—	—	—	1 400	1 800	7234BDB
	310	104	4	1.5	482	719	—	—	15.1	2 500	3 300	7234CDB
	360	144	4	1.5	631	969	—	—	—	1 600	2 000	7334DB
	360	144	4	1.5	577	888	—	—	—	1 200	1 600	7334BDB
	360	144	4	1.5	679	1 040	—	—	13.8	2 200	3 000	7334CDB
180	250	66	2	1	253	375	—	—	16.4	2 800	3 700	7936CDB
	280	92	2.1	1.1	344	506	—	—	—	1 900	2 400	7036DB
	280	92	2.1	1.1	308	457	—	—	—	1 400	1 900	7036BDB
	280	92	2.1	1.1	378	553	—	—	15.7	2 600	3 500	7036CDB
	320	104	4	1.5	477	724	—	—	—	1 700	2 200	7236DB
	320	104	4	1.5	430	657	—	—	—	1 300	1 700	7236BDB
	320	104	4	1.5	520	786	—	—	14.9	2 400	3 200	7236CDB
	380	150	4	1.5	665	1 070	—	—	—	1 500	1 900	7336DB
	380	150	4	1.5	606	976	—	—	—	1 100	1 500	7336BDB
190	260	66	2	1	257	394	—	—	16.5	2 700	3 600	7938CDB
	290	92	2.1	1.1	353	535	—	—	—	1 800	2 300	7038DB
	290	92	2.1	1.1	316	483	—	—	—	1 400	1 800	7038BDB
	290	92	2.1	1.1	388	585	—	—	15.9	2 500	3 300	7038CDB
	340	110	4	1.5	493	779	—	—	—	1 600	2 000	7238DB
	340	110	4	1.5	443	706	—	—	—	1 200	1 600	7238BDB
	340	110	4	1.5	538	848	—	—	15.1	2 200	3 000	7238CDB
	400	156	5	2	731	1 200	—	—	—	1 400	1 800	7338DB
	400	156	5	2	668	1 100	—	—	—	1 100	1 400	7338BDB

[Notes] 1) Limiting speeds shown above are applicable to machined cage bearings.
 Limiting speeds of pressed cage bearings should be kept to under 80% of this value.
 For bearings with 15° contact angle, this figure is applied to the high precision bearings ranked higher than class 5, used with machined cages or molded cages.

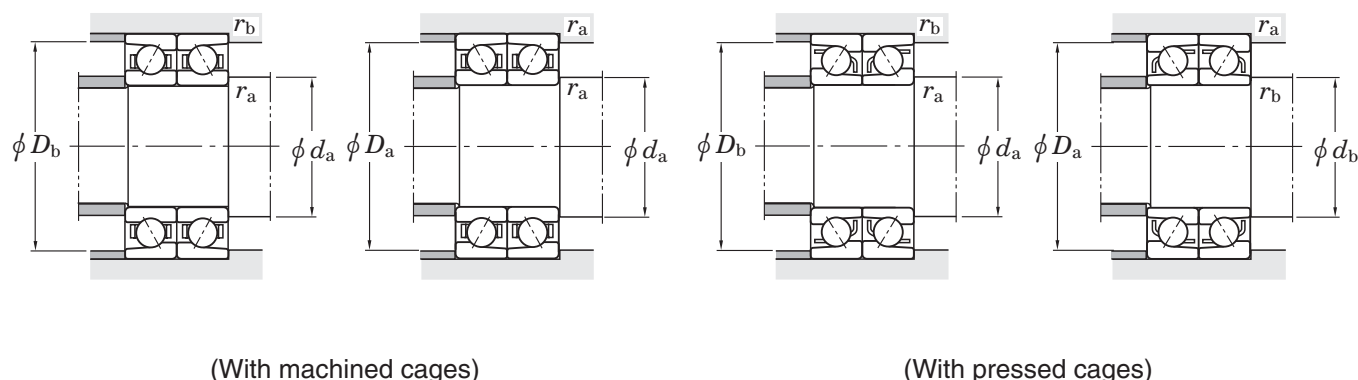

Bearing No. ²⁾		Load center spread (mm)		Mounting dimensions (mm)						(Refer.) Mass (kg)
Face-to-face DF	Tandem DT	a_1	a_2	d_a	d_b	D_a	D_b	r_a	r_b	
				min.	min.	max.	max.	max.	max.	
7034BDF	7034BDT	222.4	138.4	182	—	248	253	2	1	15.5
7034CDF	7034CDT	99.6	15.6	182	—	248	253	2	1	15.1
7234DF	7234DT	190.6	86.6	188	—	292	301.5	3	1.5	30.2
7234BDF	7234BDT	253.4	149.4	188	—	292	301.5	3	1.5	30.2
7234CDF	7234CDT	116.3	12.3	188	—	292	301.5	3	1.5	30.2
7334DF	7334DT	225.0	81.0	188	—	342	351.5	3	1.5	62.4
7334BDF	7334BDT	294.4	150.4	188	—	342	351.5	3	1.5	62.4
7334CDF	7334CDT	143.0	1.0	188	—	342	351.5	3	1.5	62.4
7936CDF	7936CDT	90.6	24.6	190	—	240	244.5	2	1	9.36
7036DF	7036DT	178.8	86.8	192	—	268	273	2	1	20.2
7036BDF	7036BDT	239.0	147.0	192	—	268	273	2	1	20.4
7036CDF	7036CDT	107.6	15.6	192	—	268	273	2	1	19.9
7236DF	7236DT	196.3	92.3	198	—	302	311.5	3	1.5	31.4
7236BDF	7236BDT	261.8	157.8	198	—	302	311.5	3	1.5	31.4
7236CDF	7236CDT	119.0	15.0	198	—	302	311.5	3	1.5	31.4
7336DF	7336DT	236.7	86.7	198	—	362	371.5	3	1.5	80.0
7336BDF	7336BDT	309.9	159.9	198	—	362	371.5	3	1.5	80.0
7938CDF	7938CDT	93.3	27.3	200	—	250	254.5	2	1	9.66
7038DF	7038DT	184.6	92.6	202	—	278	283	2	1	21.6
7038BDF	7038BDT	247.4	155.4	202	—	278	283	2	1	21.6
7038CDF	7038CDT	110.3	18.3	202	—	278	283	2	1	21.6
7238DF	7238DT	208.0	98.0	208	—	322	331.5	3	1.5	37.6
7238BDF	7238BDT	277.4	167.4	208	—	322	331.5	3	1.5	37.6
7238CDF	7238CDT	126.0	16.0	208	—	322	331.5	3	1.5	37.6
7338DF	7338DT	248.3	92.3	212	—	378	390	4	2	91.0
7338BDF	7338BDT	325.5	169.5	212	—	378	390	4	2	91.0

2) B, C or no indication after the bearing number indicates nominal contact angle of 40°, 15° and 30° respectively.

[Remark] Standard cage types used for the above bearings are described earlier in this section.

Angular contact ball bearings (matched pair)

d 200 ~ (340) mm

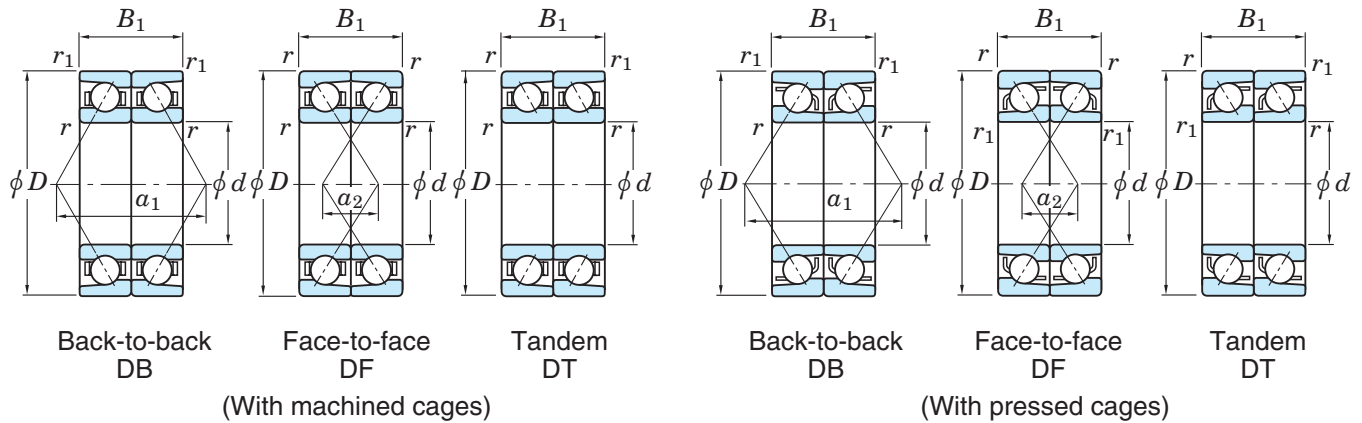

Boundary dimensions (mm)					Basic load ratings (kN)				Factor	Limiting speeds ¹⁾ (min ⁻¹)		Back-to-back DB
d	D	B_1	$r_{\min.}$	$r_{1\min.}$	With machined cages		With pressed cages			Grease lub.	Oil lub.	
					C_r	C_{Or}	C_r	C_{Or}	f_0			
200	280	76	2.1	1.1	332	509	—	—	16.3	2 500	3 300	7940CDB
	310	102	2.1	1.1	396	618	—	—	—	1 700	2 100	7040DB
	310	102	2.1	1.1	355	558	—	—	—	1 300	1 700	7040BDB
	310	102	2.1	1.1	435	676	—	—	15.7	2 300	3 100	7040CDB
	360	116	4	1.5	526	847	—	—	—	1 500	1 900	7240DB
	360	116	4	1.5	474	768	—	—	—	1 100	1 500	7240BDB
	360	116	4	1.5	575	921	—	—	15.1	2 100	2 800	7240CDB
	420	160	5	2	770	1 320	—	—	—	1 300	1 700	7340DB
	420	160	5	2	702	1 200	—	—	—	1 000	1 300	7340BDB
220	340	112	3	1.1	434	705	—	—	—	1 500	1 900	7044DB
	340	112	3	1.1	389	636	—	—	—	1 100	1 500	7044BDB
240	360	112	3	1.1	443	751	—	—	—	1 400	1 700	7048DB
	360	112	3	1.1	397	677	—	—	—	1 000	1 400	7048BDB
	440	144	4	1.5	655	1 190	—	—	—	1 200	1 500	7248DB
	440	144	4	1.5	589	1 080	—	—	—	890	1 200	7248BDB
260	400	130	4	1.5	529	956	—	—	—	1 200	1 500	7052DB
	400	130	4	1.5	473	862	—	—	—	910	1 200	7052BDB
280	420	130	4	1.5	540	1 010	—	—	—	1 100	1 400	7056DB
	420	130	4	1.5	483	906	—	—	—	850	1 100	7056BDB
300	460	148	4	1.5	693	1 360	—	—	—	1 000	1 300	7060DB
	460	148	4	1.5	621	1 230	—	—	—	770	1 000	7060BDB
320	480	148	4	1.5	710	1 440	—	—	—	950	1 200	7064DB
	480	148	4	1.5	636	1 300	—	—	—	710	950	7064BDB
340	520	164	5	2	816	1 720	—	—	—	860	1 100	7068DB

[Notes] 1) Limiting speeds shown above are applicable to machined cage bearings. Limiting speeds of pressed cage bearings should be kept to under 80% of this value. For bearings with 15° contact angle, this figure is applied to the high precision bearings ranked higher than class 5, used with machined cages or molded cages.

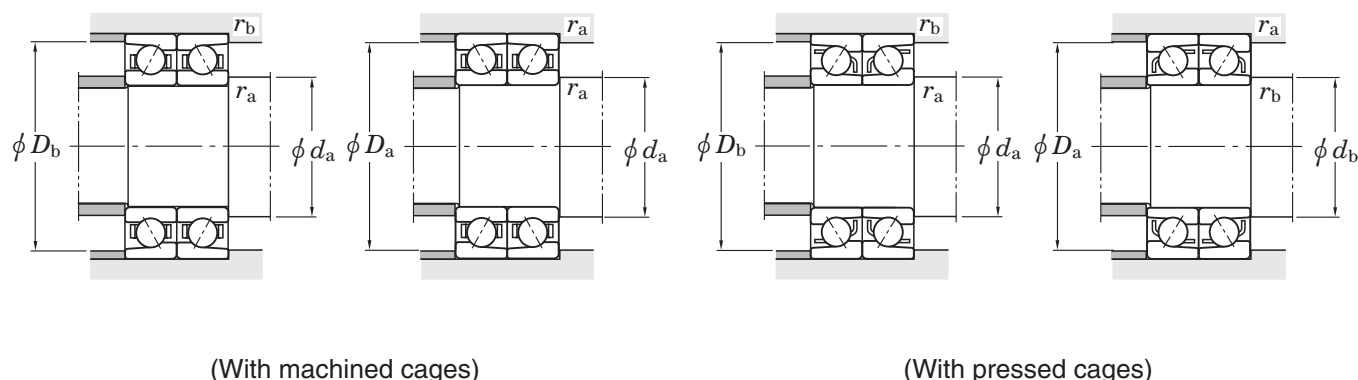

(With machined cages)

(With pressed cages)

Bearing No. ²⁾		Load center spread (mm)		Mounting dimensions (mm)						(Refer.) Mass (kg)
Face-to-face DF	Tandem DT	a_1	a_2	d_a min.	d_b min.	D_a max.	D_b max.	r_a max.	r_b max.	
7940CDF	7940CDT	102.3	26.3	212	—	268	273	2	1	13.7
7040DF	7040DT	198.3	96.3	212	—	298	303	2	1	25.4
7040BDF	7040BDT	265.0	163.0	212	—	298	303	2	1	25.4
7040CDF	7040CDT	119.3	17.3	212	—	298	303	2	1	25.4
7240DF	7240DT	219.7	103.7	218	—	342	351.5	3	1.5	44.8
7240BDF	7240BDT	292.9	176.9	218	—	342	351.5	3	1.5	44.8
7240CDF	7240CDT	133.0	17.0	218	—	342	351.5	3	1.5	44.8
7340DF	7340DT	259.0	99.0	222	—	398	410	4	2	104
7340BDF	7340BDT	340.1	180.1	222	—	398	410	4	2	104
7044DF	—	217.8	105.8	234	—	326	333	2.5	1	37.0
7044BDF	—	290.9	178.9	234	—	326	333	2.5	1	37.8
7048DF	—	229.2	117.2	254	—	346	353	2.5	1	39.4
7048BDF	—	307.7	195.7	254	—	346	353	2.5	1	40.2
7248DF	—	268.3	124.3	258	—	422	431.5	3	1.5	104
7248BDF	—	357.3	213.3	258	—	422	431.5	3	1.5	106
7052DF	—	256.7	126.7	278	—	382	391.5	3	1.5	57.4
7052BDF	—	341.9	211.9	278	—	382	391.5	3	1.5	58.6
7056DF	—	267.1	137.1	298	—	402	411.5	3	1.5	60.8
7056BDF	—	358.7	228.7	298	—	402	411.5	3	1.5	62.0
7060DF	—	293.4	145.4	318	—	442	451.5	3	1.5	87.4
7060BDF	—	392.9	244.9	318	—	442	451.5	3	1.5	89.8
7064DF	—	304.9	156.9	338	—	462	471.5	3	1.5	92.0
7064BDF	—	409.6	261.6	338	—	462	471.5	3	1.5	94.4
7068DF	—	330.3	166.3	362	—	498	510	4	2	124

2) B, C or no indication after the bearing number indicates nominal contact angle of 40°, 15° and 30° respectively.

[Remark] Standard cage types used for the above bearings are described earlier in this section.

Angular contact ball bearings (matched pair)

d (340) ~ 380 mm

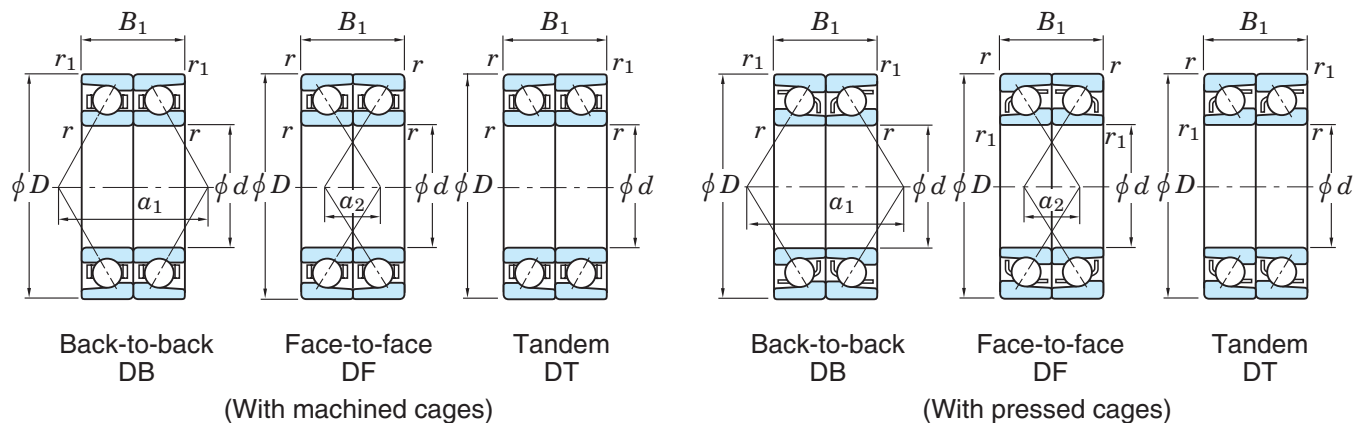

Boundary dimensions (mm)					Basic load ratings (kN)				Factor	Limiting speeds ¹⁾ (min ⁻¹)		Back-to-back DB
d	D	B_1	$r_{\min.}$	$r_{1\min.}$	With machined cages		With pressed cages			Grease lub.	Oil lub.	
					C_r	C_{0r}	C_r	C_{0r}	f_0			
340	520	164	5	2	731	1 550	—	—	—	640	860	7068BDB
	540	164	5	2	750	1 650	—	—	—	600	800	7072DB 7072BDB
380	560	164	5	2	858	1 930	—	—	—	750	940	7076DB 7076BDB
	560	164	5	2	767	1 740	—	—	—	560	750	

[Notes] 1) Limiting speeds shown above are applicable to machined cage bearings. Limiting speeds of pressed cage bearings should be kept to under 80% of this value. For bearings with 15° contact angle, this figure is applied to the high precision bearings ranked higher than class 5, used with machined cages or molded cages.

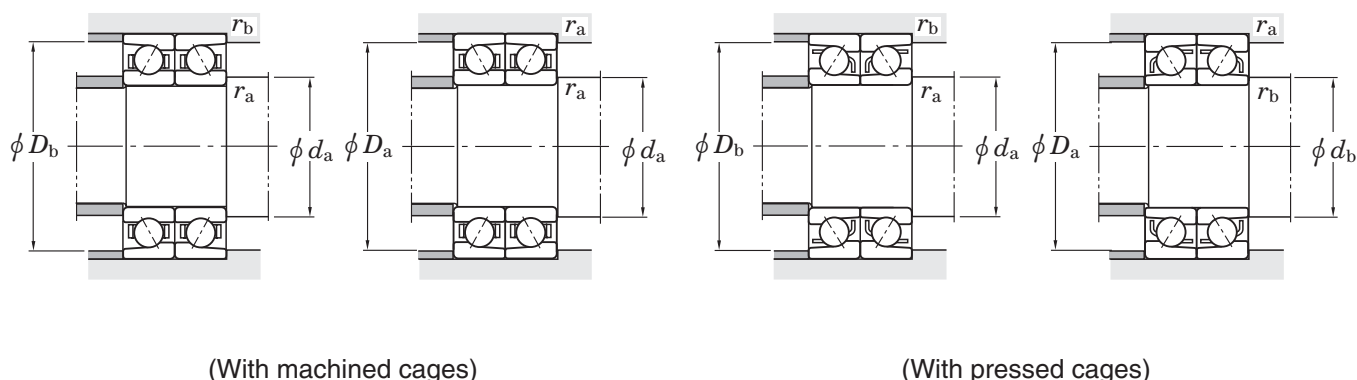

(With machined cages)

(With pressed cages)

Bearing No. ²⁾		Load center spread (mm)		Mounting dimensions (mm)						(Refer.) Mass (kg)
Face-to-face DF	Tandem DT	a_1	a_2	d_a min.	d_b min.	D_a max.	D_b max.	r_a max.	r_b max.	
7068BDF	—	442.8	278.8	362	—	498	510	4	2	127
7072DF	—	341.8	177.8	382	—	518	530	4	2	129
7072BDF	—	459.6	295.6	382	—	518	530	4	2	132
7076DF	—	353.4	189.4	402	—	538	550	4	2	134
7076BDF	—	476.4	312.4	402	—	538	550	4	2	138

2) B or no indication after the bearing number indicates nominal contact angle of 40° and 30° respectively.
 [Remark] Standard cage types used for the above bearings are described earlier in this section.

Double-row angular contact ball bearings

d 10 ~ (40) mm

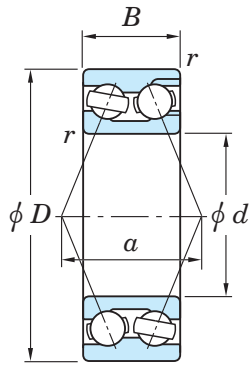

32, 33 series
(With filling slot)

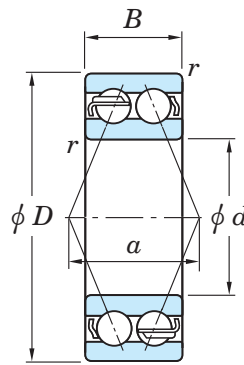

Open

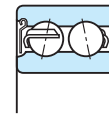

Z

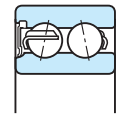

RS

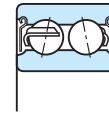

ZZ

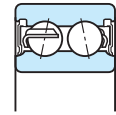

2RS

Shielded

Contact sealed

52, 53 series
(Without filling slot)

Boundary dimensions (mm)				Basic load ratings (kN)				Limiting speeds (min^{-1})			Bearing No.	
d	D	B	$r_{\text{min.}}$	Open		Shielded/sealed		Grease lub.		Oil lub.	Open	Shielded
				C_r	C_{0r}	C_r	C_{0r}	[Open Z, ZZ]	(RS, 2RS)	[Open Z]		
10	30	14.3	0.6	7.35	5.35	—	—	15 000	—	20 000	3200	—
12	32	15.9	0.6	9.70	7.15	—	—	14 000	—	18 000	3201	—
15	35	15.9	0.6	9.70	7.45	—	—	12 000	—	16 000	3202	—
	42	19	1	15.2	11.9	—	—	10 000	—	14 000	3302	—
17	40	17.5	0.6	13.8	10.8	—	—	11 000	—	14 000	3203	—
	40	17.5	0.6	13.2	8.15	12.7	8.35	11 000	11 000	14 000	5203	5203 ZZ
	47	22.2	1	21.7	17.1	—	—	9 400	—	13 000	3303	—
20	47	20.6	1	17.2	15.0	—	—	9 000	—	12 000	3204	—
	47	20.6	1	19.7	12.5	16.0	10.8	8 800	8 800	12 000	5204	5204 ZZ
	52	22.2	1.1	20.8	18.4	—	—	8 200	—	11 000	3304	—
	52	22.2	1.1	24.7	15.0	19.8	12.8	8 300	8 300	11 000	5304	5304 ZZ
25	52	20.6	1	18.9	18.2	—	—	7 800	—	10 000	3205	—
	52	20.6	1	21.4	14.8	18.9	13.8	7 700	7 700	10 000	5205	5205 ZZ
	62	25.4	1.1	28.9	26.5	—	—	6 800	—	9 100	3305	—
	62	25.4	1.1	32.7	20.8	27.5	18.5	6 900	6 900	9 200	5305	5305 ZZ
30	62	23.8	1	27.3	27.0	—	—	6 500	—	8 700	3206	—
	62	23.8	1	29.7	21.3	25.4	18.3	6 400	6 400	8 600	5206	5206 ZZ
	72	30.2	1.1	38.1	36.1	—	—	5 800	—	7 800	3306	—
	72	30.2	1.1	41.0	28.5	34.3	25.2	5 800	5 800	7 700	5306	5306 ZZ
35	72	27	1.1	36.8	37.5	—	—	5 600	—	7 500	3207	—
	72	27	1.1	39.2	29.0	31.7	24.6	5 500	5 500	7 300	5207	5207 ZZ
	80	34.9	1.5	48.6	46.8	—	—	5 200	—	7 000	3307	—
	80	34.9	1.5	51.2	36.2	46.1	32.8	5 100	5 100	6 800	5307	5307 ZZ
40	80	30.2	1.1	42.0	43.9	—	—	5 000	—	6 700	3208	—

[Note] 1) The maximum value of d_a is applied to shielded and sealed type bearings.

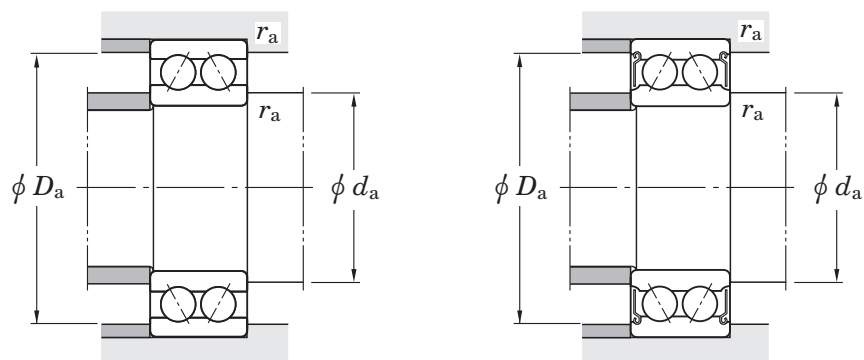

Sealed	Load center spread (mm) Open <i>a</i>	Mounting dimensions ¹⁾ (mm)				(Refer.) Mass (kg)
		<i>d_a</i> min.	<i>d_a</i> max.	<i>D_a</i> max.	<i>r_a</i> max.	
—	19.5	14.5	—	25.5	0.6	0.052
—	21.7	16.5	—	27.5	0.6	0.063
—	23.6	19.5	—	30.5	0.6	0.072
—	27.6	20.5	—	36.5	1	0.132
—	26.6	21.5	—	35.5	0.6	0.100
5203 2RS	20.0	21.5	23.5	35.5	0.6	0.091
—	31.0	22.5	—	41.5	1	0.192
—	31.5	25.5	—	41.5	1	0.170
5204 2RS	23.5	25.5	26.6	41.5	1	0.120
—	33.8	27	—	45	1	0.230
5304 2RS	25.9	27	28.3	45	1	0.230
—	34.4	30.5	—	46.5	1	0.190
5205 2RS	26.1	30.5	32.3	46.5	1	0.190
—	40.5	32	—	55	1	0.369
5305 2RS	31.1	32	33.4	55	1	0.340
—	40.7	35.5	—	56.5	1	0.320
5206 2RS	30.8	35.5	38.6	56.5	1	0.290
—	47.2	37	—	65	1	0.585
5306 2RS	36.2	37	41.3	65	1	0.510
—	46.9	42	—	65	1	0.480
5207 2RS	36.1	42	43.9	65	1	0.430
—	53.4	43.5	—	71.5	1.5	0.816
5307 2RS	41.0	43.5	45.5	71.5	1.5	0.790
—	52.6	47	—	73	1	0.650

[Remark] Standard cage types used for the above bearings are described earlier in this section.

Double-row angular contact ball bearings

d (40) ~ (70) mm

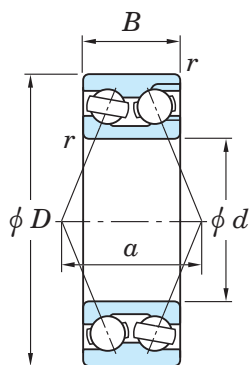

32, 33 series
(With filling slot)

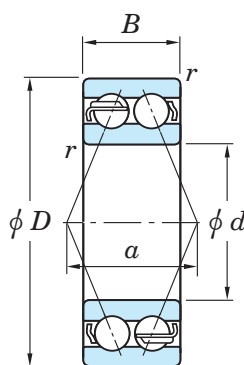

Open

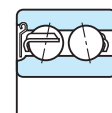

Z

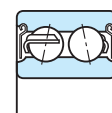

ZZ

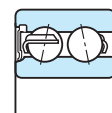

RS

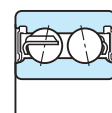

2RS

Shielded
(Without filling slot)

Contact
sealed

Boundary dimensions (mm)				Basic load ratings (kN)				Limiting speeds (min^{-1})			Bearing No.	
d	D	B	$r_{\text{min.}}$	Open		Shielded/sealed		Grease lub.		Oil lub.	Open	Shielded
				C_r	C_{0r}	C_r	C_{0r}	[Open Z, ZZ]	(RS, 2RS)	[Open Z]		
40	80	30.2	1.1	44.4	33.6	36.5	29.1	5 000	5 000	6 700	5208	5208 ZZ
	90	36.5	1.5	54.1	53.8	—	—	4 600	—	6 100	3308	—
	90	36.5	1.5	62.7	45.4	51.4	37.8	4 600	4 600	6 100	5308	5308 ZZ
45	85	30.2	1.1	45.4	51.4	—	—	4 600	—	6 100	3209	—
	85	30.2	1.1	49.9	38.4	41.7	33.9	4 600	4 600	6 100	5209	5209 ZZ
	100	39.7	1.5	66.1	67.3	—	—	4 100	—	5 500	3309	—
	100	39.7	1.5	75.1	55.7	68.9	51.4	4 100	4 100	5 500	5309	5309 ZZ
50	90	30.2	1.1	45.1	52.1	—	—	4 300	—	5 700	3210	—
	90	30.2	1.1	53.3	43.6	44.1	37.9	4 300	4 300	5 600	5210	5210 ZZ
	110	44.4	2	86.1	88.6	—	—	3 800	—	5 000	3310	—
	110	44.4	2	88.5	67.0	81.8	62.2	3 600	3 600	4 800	5310	5310 ZZ
55	100	33.3	1.5	50.9	60.2	—	—	3 900	—	5 100	3211	—
	100	33.3	1.5	65.9	55.2	52.9	44.7	3 800	3 800	5 100	5211	5211 ZZ
	120	49.2	2	101	106	—	—	3 400	—	4 500	3311	—
	120	49.2	2	110	85.1	95.7	74.3	3 300	3 300	4 500	5311	5311 ZZ
60	110	36.5	1.5	64.0	76.8	—	—	3 500	—	4 700	3212	—
	110	36.5	1.5	74.4	60.8	62.6	55.9	3 500	3 500	4 700	5212	5212 ZZ
	130	54	2.1	125	132	—	—	3 100	—	4 200	3312	—
	130	54	2.1	126	98.7	110	87.1	3 100	3 100	4 100	5312	5312 ZZ
65	120	38.1	1.5	76.4	97.4	—	—	3 200	—	4 300	3213	—
	120	38.1	1.5	86.9	75.3	69.2	63.1	3 200	3 200	4 300	5213	5213 ZZ
	140	58.7	2.1	142	153	—	—	2 900	—	3 900	3313	—
	140	58.7	2.1	142	113	142	113	2 900	2 900	3 900	5313	5313 ZZ
70	125	39.7	1.5	77.9	96.4	—	—	3 100	—	4 100	3214	—
	125	39.7	1.5	94.5	82.6	76.3	70.3	3 100	3 100	4 100	5214	5214 ZZ
	150	63.5	2.1	151	160	—	—	2 700	—	3 600	3314	—

[Note] 1) The maximum value of d_a is applied to shielded and sealed type bearings.

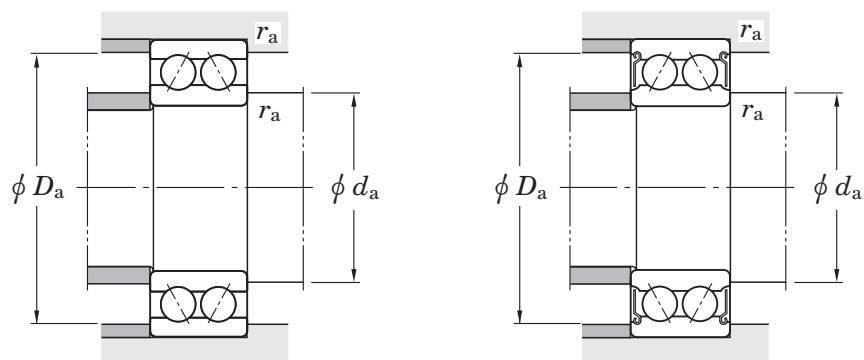

Sealed	Load center spread (mm) Open <i>a</i>	Mounting dimensions ¹⁾ (mm)				(Refer.) Mass (kg)
		<i>d_a</i> min.	<i>d_a</i> max.	<i>D_a</i> max.	<i>r_a</i> max.	
5208 2RS	39.2	47	49.5	73	1	0.570
—	58.9	48.5	—	81.5	1.5	1.07
5308 2RS	44.9	48.5	52.1	81.5	1.5	1.05
—	56.3	52	—	78	1	0.710
5209 2RS	42.2	52	55.3	78	1	0.620
—	65.6	53.5	—	91.5	1.5	1.42
5309 2RS	51.0	53.5	58.2	91.5	1.5	1.42
—	58.8	57	—	83	1	0.760
5210 2RS	44.5	57	58.9	83	1	0.670
—	71.7	60	—	100	2	1.95
5310 2RS	56.6	60	64.4	100	2	1.93
—	65.0	63.5	—	91.5	1.5	1.05
5211 2RS	50.2	63.5	66.2	91.5	1.5	0.960
—	79.3	65	—	110	2	2.53
5311 2RS	61.6	65	71.8	110	2	2.30
—	71.3	68.5	—	101.5	1.5	1.40
5212 2RS	53.8	68.5	74.1	101.5	1.5	1.36
—	87.4	72	—	118	2	3.24
5312 2RS	67.2	72	79.2	118	2	3.16
—	76.8	73.5	—	111.5	1.5	1.75
5213 2RS	58.8	73.5	79.0	111.5	1.5	1.66
—	92.7	77	—	128	2	4.08
5313 2RS	70.9	77	85.9	128	2	3.91
—	80.7	78.5	—	116.5	1.5	1.92
5214 2RS	61.4	78.5	83.5	116.5	1.5	1.81
—	99.7	82	—	138	2	5.04

[Remark] Standard cage types used for the above bearings are described earlier in this section.

Double-row angular contact ball bearings

d (70) ~ 110 mm

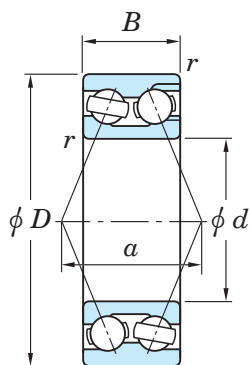

32, 33 series
(With filling slot)

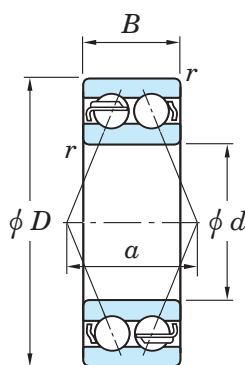

Open

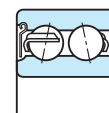

Z

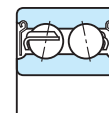

ZZ

Shielded

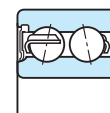

RS

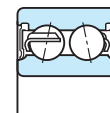

2RS

Contact sealed

52, 53 series
(Without filling slot)

Boundary dimensions (mm)				Basic load ratings (kN)				Limiting speeds (min^{-1})			Bearing No.	
d	D	B	$r_{\text{min.}}$	Open		Shielded/sealed		Grease lub.		Oil lub.	Open	Shielded
				C_r	C_{0r}	C_r	C_{0r}	[Open Z, ZZ]	(RS, 2RS)	[Open Z]		
70	150	63.5	2.1	160	129	160	129	2 700	2 700	3 600	5314	5314 ZZ
	160	68.3	2.1	169	189	—	—	2 500	—	3 300	3215	—
75	160	68.3	2.1	174	147	174	147	2 500	2 500	3 300	5315	5315 ZZ
	160	68.3	2.1	174	147	174	147	2 500	2 500	3 300	5315	5315 ZZ
80	140	44.4	2	97.5	121	—	—	2 700	—	3 600	3216	—
	170	68.3	2.1	184	213	—	—	2 400	—	3 100	3316	—
85	150	49.2	2	114	143	—	—	2 500	—	3 400	3217	—
	180	73	3	188	219	—	—	2 200	—	3 000	3317	—
90	160	52.4	2	132	167	—	—	2 400	—	3 100	3218	—
	190	73	3	205	242	—	—	2 100	—	2 800	3318	—
95	170	55.6	2.1	152	193	—	—	2 200	—	3 000	3219	—
	200	77.8	3	218	270	—	—	2 000	—	2 600	3319	—
100	180	60.3	2.1	172	221	—	—	2 100	—	2 800	3220	—
	215	82.6	3	249	324	—	—	1 800	—	2 500	3320	—
105	190	65.1	2.1	182	237	—	—	2 000	—	2 600	3221	—
	225	87.3	3	265	354	—	—	1 800	—	2 300	3321	—
110	200	69.8	2.1	201	263	—	—	1 900	—	2 500	3222	—
	240	92.1	3	281	388	—	—	1 600	—	2 200	3322	—

[Note] 1) The maximum value of d_a is applied to shielded and sealed type bearings.

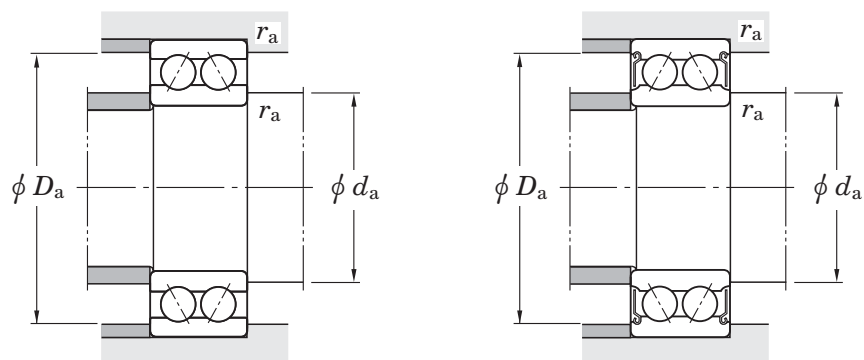

Sealed	Load center spread (mm) Open <i>a</i>	Mounting dimensions ¹⁾ (mm)				(Refer.) Mass (kg)
		<i>d_a</i> min.	<i>d_a</i> max.	<i>D_a</i> max.	<i>r_a</i> max.	
5314 2RS	76.0	82	92.9	138	2	4.89
—	84.7	83.5	—	121.5	1.5	2.10
—	108.7	87	—	148	2	6.16
5315 2RS	81.5	87	99.6	148	2	5.97
—	90.7	90	—	130	2	2.64
—	113.1	92	—	158	2	6.93
—	98.4	95	—	140	2	3.39
—	118.8	99	—	166	2.5	8.30
—	104.1	100	—	150	2	4.14
—	125.5	104	—	176	2.5	9.23
—	110.6	107	—	158	2	5.00
—	132.2	109	—	186	2.5	10.9
—	116.8	112	—	168	2	6.10
—	140.4	114	—	201	2.5	13.5
—	124.2	117	—	178	2	7.37
—	148.1	119	—	211	2.5	15.6
—	131.4	122	—	188	2	8.80
—	156.4	124	—	226	2.5	18.9

[Remark] Standard cage types used for the above bearings are described earlier in this section.

Four-point contact ball bearings

d 20 ~ 75 mm

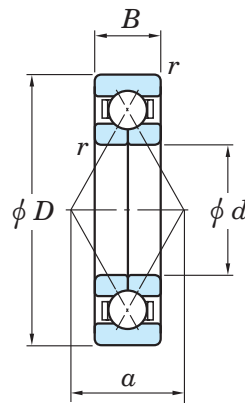

Boundary dimensions (mm)				Basic load ratings (kN)		Limiting speeds (min^{-1})		Bearing No.	Load center spread (mm) a	
d	D	B	r min.	C_r	C_{0r}	Grease lub.	Oil lub.			
20	47	14	1	23.5	15.3	12 000	16 000	6204BI	23.5	
	52	15	1.1	27.4	18.1	11 000	15 000			
25	52	15	1	26.7	18.8	10 000	14 000	6205BI	27.0	
	62	17	1.1	40.8	28.0	9 200	13 000			
30	62	16	1	36.3	27.6	8 600	12 000	6206BI	32.6	
	72	19	1.1	49.5	36.6	7 800	11 000			
35	72	17	1.1	47.1	36.7	7 500	10 000	6207BI	37.5	
	80	21	1.5	61.2	46.4	7 000	9 600			
40	80	18	1.1	55.9	46.5	6 600	9 000	6208BI	42.7	
	90	23	1.5	74.1	57.6	6 200	8 500			
45	85	19	1.1	58.7	51.3	6 100	8 400	6209BI	45.9	
	100	25	1.5	87.9	70.0	5 500	7 600			
50	90	20	1.1	65.4	58.0	5 700	7 900	6210BI	49.0	
	110	27	2	103	83.7	5 000	6 900			
55	100	21	1.5	80.0	72.3	5 200	7 100	6211BI	54.3	
	120	29	2	119	98.5	4 500	6 200			
60	110	22	1.5	91.7	87.6	4 600	6 300	6212BI	60.6	
	130	31	2.1	145	126	4 100	5 700			
65	120	23	1.5	95.1	90.1	4 300	5 900	6213BI	64.8	
	140	33	2.1	164	145	3 800	5 300			
70	125	24	1.5	103	99.0	4 100	5 600	6214BI	68.3	
	150	35	2.1	184	165	3 600	4 900			
75	130	25	1.5	108	108	3 900	5 300	6215BI	71.8	
	160	37	2.1	200	187	3 400	4 600			

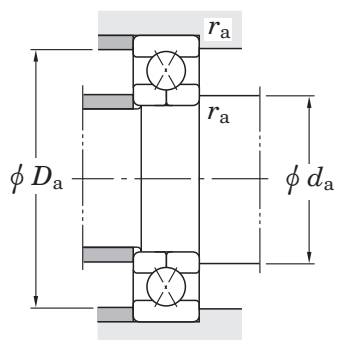

Mounting dimensions (mm)			(Refer.) Mass (kg)
d_a min.	D_a max.	r_a max.	
25.5	41.5	1	0.129
27.0	45	1	0.179
30.5	46.5	1	0.156
32	55	1	0.285
35.5	56.5	1	0.241
37	65	1	0.426
42	65	1	0.351
43.5	71.5	1.5	0.565
47	73	1	0.451
48.5	81.5	1.5	0.778
52	78	1	0.512
53.5	91.5	1.5	1.04
57	83	1	0.575
60	100	2	1.35
63.5	91.5	1.5	0.763
65	110	2	1.72
68.5	101.5	1.5	0.983
72	118	2	2.17
73.5	111.5	1.5	1.23
77	128	2	2.67
78.5	116.5	1.5	1.35
82	138	2	3.25
83.5	121.5	1.5	1.47
87	148	2	3.90

Four-point contact ball bearings

d 80 ~ 110 mm

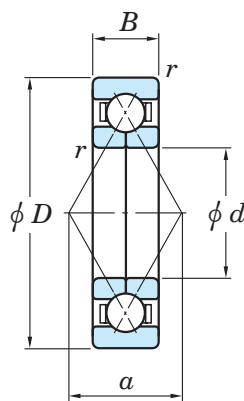

Boundary dimensions (mm)				Basic load ratings (kN)		Limiting speeds (min ⁻¹)		Bearing No.	Load center spread (mm) a	
d	D	B	r min.	C_r	C_{0r}	Grease lub.	Oil lub.			
80	140	26	2	126	128	3 600	4 900	6216BI	77.0	
	170	39	2.1	217	210	3 100	4 300	6316BI	87.5	
85	150	28	2	146	150	3 400	4 600	6217BI	82.3	
	180	41	3	234	234	3 000	4 100	6317BI	92.8	
90	160	30	2	167	173	3 100	4 300	6218BI	87.5	
	190	43	3	252	260	2 800	3 800	6318BI	98.0	
95	170	32	2.1	190	198	3 000	4 100	6219BI	92.8	
	200	45	3	269	287	2 600	3 600	6319BI	103.3	
100	180	34	2.1	201	213	2 800	3 800	6220BI	98.0	
110	200	38	2.1	242	275	2 500	3 400	6222BI	108.5	

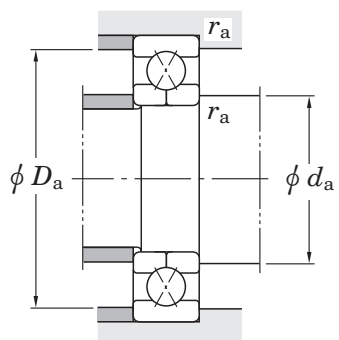

Mounting dimensions (mm)			(Refer.)
d_a min.	D_a max.	r_a max.	Mass (kg)
90	130	2	1.80
92	158	2	4.63
95	140	2	2.25
99	166	2.5	5.45
100	150	2	2.77
104	176	2.5	6.36
107	158	2	3.37
109	186	2.5	7.37
112	168	2	4.02
122	188	2	5.64

KOYO



Self-aligning ball bearings

Self-aligning ball bearings have a spherical outer ring raceway, the center of whose curvature meets that of the bearing itself, so that the inner ring, balls and cage continue to rotate, aligning themselves if they have become misaligned within design limits.

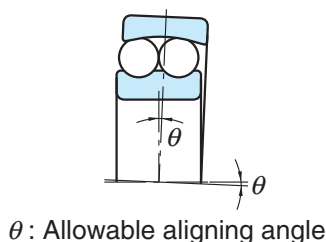

This type of bearing is suitable when the displacement of the centers around which the shaft and housing rotate and shaft deflection are likely to occur.

Bearings with a tapered bore can easily be fit to the shaft with an adapter assembly.

Self-aligning ball bearings

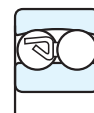

Cylindrical bore

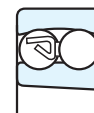

Tapered bore

Bore diameter **5 – 110 mm**



Sealed type

Bore diameter **10 – 110 mm**

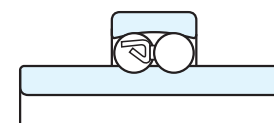

Extended inner ring type

Bore diameter **20 – 60 mm**

Adapter assemblies



Bore diameter **17 – 100 mm**

Boundary dimensions	The dimensions of standard series are as specified in JIS B 1512.
Tolerances	As specified in JIS B 1514-1, class 0. (refer to Table 7-3 on pp. A 54 – A 57.)
Radial internal clearance	As specified in JIS B 1520. (refer to Table 10-6 on p. A 99.)
Recommended fits	Refer to Table 9-4 on pp. A 85, 86.
Standard cages	<ul style="list-style-type: none"> • Staggered type pressed steel cage (application : all dimensional range of 12, 13, 112, 113, 22...2RS and 23...2RS series) • Snap type pressed steel cage (application : all dimensional range of 22 series and those of No. 2300 thru 2316.) • Copper alloy machined cage (application : bearings of No. 2317 thru 2322)
Allowable aligning angle	<ul style="list-style-type: none"> • 12 and 22 series 0.044 rad (2.5°) • 13 and 23 series 0.052 rad (3°) • 22...2RS and 23...2RS series 0.026 rad (1.5°)

Dynamic equivalent radial load

$$P_r = X F_r + Y F_a$$

$F_a/F_r \leq e$		$F_a/F_r > e$	
X	Y	X	Y
1	Y_1	0.65	Y_2

Static equivalent radial load

$$P_{0r} = F_r + Y_0 F_a$$

Refer to the bearing specification table for values of e , Y_1 , Y_2 and Y_0 .

Self-aligning ball bearings open type

d 5 ~ (20) mm

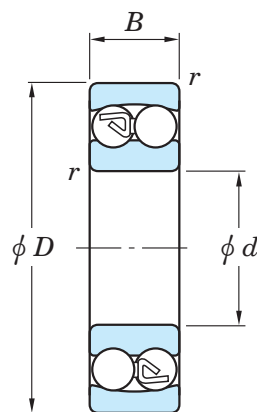

Cylindrical bore

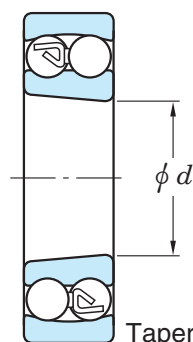

Tapered bore

Boundary dimensions (mm)				Basic load ratings (kN)		Limiting speeds (min ⁻¹)		Bearing No.	
d	D	B	$r_{\min.}$	C_r	C_{0r}	Grease lub.	Oil lub.	Cylindrical bore	Tapered bore
5	19	6	0.3	2.55	0.48	30 000	37 000	135	—
6	19	6	0.3	2.50	0.48	30 000	37 000	126	—
7	22	7	0.3	2.65	0.56	27 000	33 000	127	—
8	22	7	0.3	2.60	0.56	26 000	33 000	108	—
9	26	8	0.6	3.80	0.80	23 000	29 000	129	—
10	30	9	0.6	5.50	1.20	23 000	28 000	1200	—
	30	14	0.6	7.40	1.60	23 000	29 000	2200	—
	35	11	0.6	7.25	1.60	20 000	24 000	1300	—
	35	17	0.6	9.30	2.10	18 000	24 000	2300	—
12	32	10	0.6	5.60	1.25	21 000	26 000	1201	—
	32	14	0.6	7.65	1.75	21 000	26 000	2201	—
	37	12	1	9.40	2.15	18 000	22 000	1301	—
	37	17	1	9.70	2.30	16 000	22 000	2301	—
15	35	11	0.6	7.45	1.75	18 000	22 000	1202	—
	35	14	0.6	7.70	1.85	18 000	22 000	2202	—
	42	13	1	9.55	2.30	16 000	20 000	1302	—
	42	17	1	12.1	2.90	14 000	20 000	2302	—
17	40	12	0.6	7.90	2.00	16 000	20 000	1203	—
	40	16	0.6	9.80	2.40	16 000	20 000	2203	—
	47	14	1	12.5	3.20	14 000	17 000	1303	—
	47	19	1	14.5	3.60	13 000	18 000	2303	—
20	47	14	1	9.90	2.60	14 000	17 000	1204	1204K
	47	18	1	12.6	3.30	14 000	17 000	2204	2204K
	52	15	1.1	12.4	3.30	13 000	15 000	1304	1304K

[Remark] Standard cage types used for the above bearings are described earlier in this section.

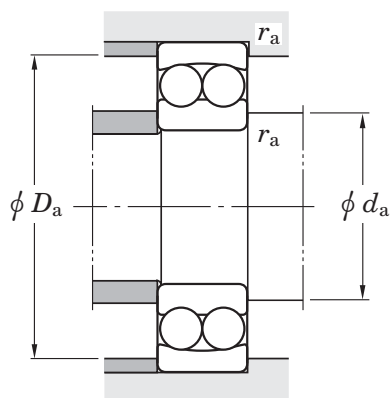

	Mounting dimensions (mm)			Con- stant e	Axial load factors			(Refer.) Mass (kg)	
	d_a min.	D_a max.	r_a max.		Y_1	Y_2	Y_0	Cylindrical bore	Tapered bore
	7	17	0.3	0.34	1.86	2.87	1.94	0.009	—
	8	17	0.3	0.34	1.86	2.87	1.94	0.009	—
	9	20	0.3	0.35	1.82	2.82	1.91	0.014	—
	10	20	0.3	0.35	1.82	2.82	1.91	0.014	—
	13	22	0.6	0.34	1.86	2.87	1.94	0.022	—
	14	26	0.6	0.33	1.92	2.97	2.01	0.034	—
	14	26	0.6	0.59	1.07	1.65	1.12	0.047	—
	14	31	0.6	0.34	1.85	2.87	1.94	0.058	—
	14	31	0.6	0.59	1.07	1.66	1.13	0.085	—
	16	28	0.6	0.33	1.89	2.93	1.98	0.040	—
	16	28	0.6	0.53	1.18	1.83	1.24	0.053	—
	17	32	1	0.36	1.77	2.74	1.86	0.067	—
	17	32	1	0.54	1.17	1.81	1.23	0.095	—
	19	31	0.6	0.33	1.90	2.95	2.00	0.049	—
	19	31	0.6	0.50	1.27	1.97	1.33	0.060	—
	20	37	1	0.34	1.86	2.88	1.95	0.094	—
	20	37	1	0.50	1.27	1.96	1.33	0.114	—
	21	36	0.6	0.31	2.03	3.14	2.12	0.073	—
	21	36	0.6	0.50	1.27	1.96	1.33	0.088	—
	22	42	1	0.33	1.92	2.97	2.01	0.130	—
	22	42	1	0.49	1.28	1.98	1.34	0.158	—
	25	42	1	0.29	2.16	3.35	2.27	0.120	0.118
	25	42	1	0.48	1.31	2.02	1.37	0.140	0.136
	26.5	45.5	1	0.30	2.12	3.28	2.22	0.163	0.161

Self-aligning ball bearings open type

d (20) ~ 50 mm

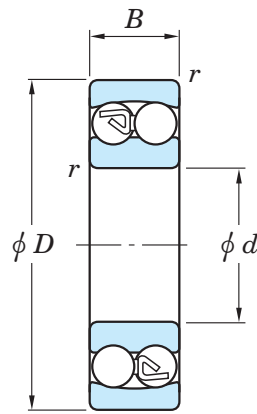

Cylindrical bore

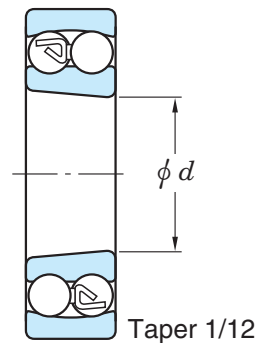

Tapered bore

Boundary dimensions (mm)				Basic load ratings (kN)		Limiting speeds (min ⁻¹)		Bearing No.	
d	D	B	r min.	C_r	C_{0r}	Grease lub.	Oil lub.	Cylindrical bore	Tapered bore
20	52	21	1.1	18.0	4.70	11 000	15 000	2304	2304K
25	52	15	1	12.1	3.30	12 000	14 000	1205	1205K
	52	18	1	12.6	3.50	12 000	15 000	2205	2205K
	62	17	1.1	18.0	5.00	9 900	12 000	1305	1305K
	62	24	1.1	24.4	6.60	9 400	13 000	2305	2305K
30	62	16	1	15.6	4.65	9 900	12 000	1206	1206K
	62	20	1	15.6	4.65	10 000	12 000	2206	2206K
	72	19	1.1	21.3	6.30	8 700	11 000	1306	1306K
	72	27	1.1	31.4	8.75	8 000	11 000	2306	2306K
35	72	17	1.1	15.8	5.10	8 500	10 000	1207	1207K
	72	23	1.1	21.6	6.60	8 500	10 000	2207	2207K
	80	21	1.5	25.1	7.85	7 600	9 300	1307	1307K
	80	31	1.5	39.4	11.3	7 100	9 800	2307	2307K
40	80	18	1.1	19.2	6.50	7 500	9 200	1208	1208K
	80	23	1.1	22.4	7.40	7 600	9 300	2208	2208K
	90	23	1.5	29.5	9.70	6 900	8 400	1308	1308K
	90	33	1.5	44.9	13.5	6 200	8 600	2308	2308K
45	85	19	1.1	21.8	7.35	7 000	8 500	1209	1209K
	85	23	1.1	23.3	8.15	7 000	8 500	2209	2209K
	100	25	1.5	38.1	12.7	6 100	7 500	1309	1309K
	100	36	1.5	54.4	16.7	5 600	7 700	2309	2309K
50	90	20	1.1	22.7	8.10	6 500	7 900	1210	1210K
	90	23	1.1	23.3	8.50	6 500	7 900	2210	2210K
	110	27	2	43.4	14.1	5 600	6 800	1310	1310K
	110	40	2	64.6	20.3	5 100	7 000	2310	2310K

[Remark] Standard cage types used for the above bearings are described earlier in this section.

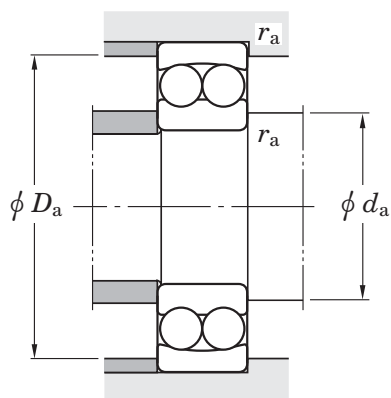

	Mounting dimensions (mm)			Con- stant <i>e</i>	Axial load factors			(Refer.) Mass (kg)	
	<i>d_a</i> min.	<i>D_a</i> max.	<i>r_a</i> max.		<i>Y</i> ₁	<i>Y</i> ₂	<i>Y</i> ₀	Cylindrical bore	Tapered bore
	26.5	45.5	1	0.49	1.29	2.00	1.35	0.209	0.205
	30	47	1	0.28	2.28	3.52	2.39	0.141	0.138
	30	47	1	0.40	1.58	2.45	1.66	0.163	0.158
	31.5	55.5	1	0.27	2.31	3.57	2.42	0.257	0.252
	31.5	55.5	1	0.46	1.36	2.10	1.42	0.335	0.327
	35	57	1	0.25	2.55	3.94	2.67	0.220	0.216
	35	57	1	0.35	1.79	2.77	1.87	0.260	0.254
	36.5	65.5	1	0.26	2.40	3.72	2.52	0.387	0.381
	36.5	65.5	1	0.44	1.44	2.23	1.51	0.500	0.489
	41.5	65.5	1	0.23	2.71	4.20	2.84	0.323	0.317
	41.5	65.5	1	0.37	1.71	2.65	1.79	0.403	0.396
	43	72	1.5	0.25	2.48	3.84	2.60	0.510	0.502
	43	72	1.5	0.45	1.39	2.15	1.46	0.675	0.657
	46.5	73.5	1	0.22	2.83	4.38	2.97	0.417	0.411
	46.5	73.5	1	0.33	1.92	2.96	2.01	0.505	0.494
	48	82	1.5	0.25	2.57	3.98	2.69	0.715	0.704
	48	82	1.5	0.43	1.47	2.27	1.54	0.925	0.903
	51.5	78.5	1	0.21	2.94	4.56	3.09	0.465	0.459
	51.5	78.5	1	0.30	2.09	3.23	2.19	0.545	0.533
	53	92	1.5	0.25	2.56	3.95	2.68	0.957	0.942
	53	92	1.5	0.42	1.51	2.33	1.58	1.23	1.20
	56.5	83.5	1	0.21	3.07	4.76	3.22	0.525	0.515
	56.5	83.5	1	0.27	2.33	3.61	2.45	0.590	0.577
	59	101	2	0.23	2.70	4.17	2.83	1.21	1.19
	59	101	2	0.40	1.56	2.41	1.63	1.64	1.60

Self-aligning ball bearings open type

d 55 ~ (85) mm

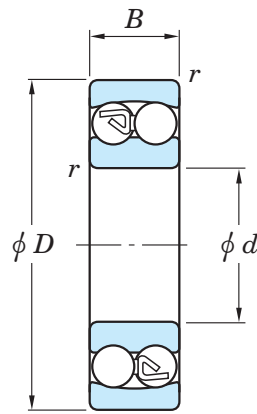

Cylindrical bore

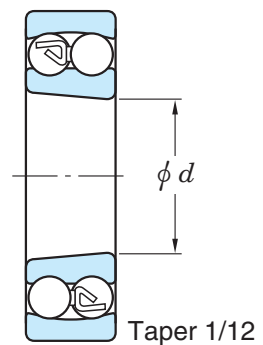

Tapered bore

Boundary dimensions (mm)				Basic load ratings (kN)		Limiting speeds (min ⁻¹)		Bearing No.	
d	D	B	r min.	C_r	C_{0r}	Grease lub.	Oil lub.	Cylindrical bore	Tapered bore
55	100	21	1.5	26.8	10.0	5 800	7 100	1211	1211K
	100	25	1.5	26.8	10.0	5 800	7 100	2211	2211K
	120	29	2	51.3	17.9	5 000	6 200	1311	1311K
	120	43	2	75.3	24.0	4 600	6 400	2311	2311K
60	110	22	1.5	30.2	11.5	5 200	6 400	1212	1212K
	110	28	1.5	34.1	12.6	5 300	6 500	2212	2212K
	130	31	2.1	57.2	20.8	4 500	5 500	1312	1312K
	130	46	2.1	87.2	28.3	4 200	5 800	2312	2312K
65	120	23	1.5	31.0	12.5	4 800	5 800	1213	1213K
	120	31	1.5	43.5	16.4	4 900	5 900	2213	2213K
	140	33	2.1	61.7	22.9	4 300	5 200	1313	1313K
	140	48	2.1	95.8	32.5	3 800	5 300	2313	2313K
70	125	24	1.5	34.6	13.8	4 600	5 700	1214	—
	125	31	1.5	43.9	17.1	4 600	5 600	2214	—
	150	35	2.1	74.0	27.7	4 000	4 900	1314	—
	150	51	2.1	89.6	31.7	3 600	4 900	2314	—
75	130	25	1.5	38.8	15.7	4 300	5 300	1215	1215K
	130	31	1.5	44.2	17.8	4 300	5 300	2215	2215K
	160	37	2.1	78.9	29.9	4 000	4 900	1315	1315K
	160	55	2.1	103	36.8	3 400	4 600	2315	2315K
80	140	26	2	39.8	17.0	4 000	4 900	1216	1216K
	140	33	2	49.0	19.9	4 100	5 000	2216	2216K
	170	39	2.1	88.1	33.1	3 500	4 300	1316	1316K
	170	58	2.1	129	45.7	3 100	4 300	2316	2316K
85	150	28	2	49.2	20.8	3 800	4 600	1217	1217K

[Remark] Standard cage types used for the above bearings are described earlier in this section.

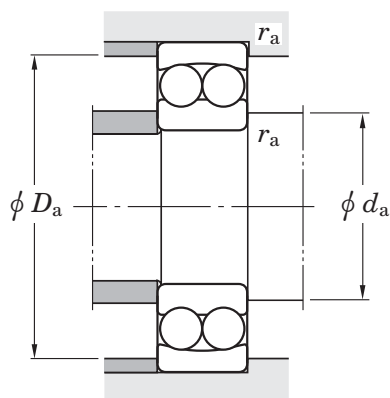

[Note] Protruding distance of balls

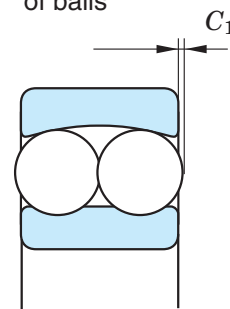

Balls of the following bearing protrude by C_1 from the bearing side.

Bearing No.	C_1 (mm)
2216	0.2 (approx.)

	Mounting dimensions (mm)			Con-stant e	Axial load factors			(Refer.) Mass (kg)	
	d_a min.	D_a max.	r_a max.		Y_1	Y_2	Y_0	Cylindrical bore	Tapered bore
	63	92	1.5	0.20	3.19	4.94	3.34	0.705	0.693
	63	92	1.5	0.27	2.35	3.64	2.47	0.810	0.792
	64	111	2	0.23	2.70	4.18	2.83	1.58	1.56
	64	111	2	0.41	1.53	2.37	1.60	2.10	2.05
	68	102	1.5	0.19	3.37	5.22	3.53	0.900	0.885
	68	102	1.5	0.28	2.26	3.49	2.36	1.09	1.07
	71	119	2	0.22	2.91	4.50	3.05	1.96	1.93
	71	119	2	0.39	1.62	2.51	1.70	2.60	2.53
	73	112	1.5	0.17	3.67	5.68	3.84	1.15	1.13
	73	112	1.5	0.28	2.24	3.47	2.35	1.46	1.43
	76	129	2	0.23	2.73	4.23	2.86	2.45	2.41
	76	129	2	0.38	1.66	2.58	1.74	3.23	3.15
	78	117	1.5	0.18	3.48	5.38	3.64	1.26	—
	78	117	1.5	0.26	2.42	3.74	2.53	1.52	—
	81	139	2	0.22	2.84	4.40	2.98	2.99	—
	81	139	2	0.35	1.82	2.82	1.91	4.23	—
	83	122	1.5	0.17	3.60	5.58	3.77	1.36	1.34
	83	122	1.5	0.25	2.49	3.85	2.61	1.62	1.58
	86	149	2	0.23	2.80	4.33	2.93	3.56	3.51
	86	149	2	0.34	1.86	2.88	1.95	5.13	5.01
	89	131	2	0.16	3.90	6.03	4.08	1.67	1.64
	89	131	2	0.26	2.42	3.75	2.54	2.01	1.97
	91	159	2	0.22	2.90	4.49	3.04	4.18	4.12
	91	159	2	0.34	1.87	2.90	1.96	6.10	5.96
	94	141	2	0.17	3.61	5.59	3.78	2.07	2.04

Self-aligning ball bearings open type

d (85) ~ 110 mm

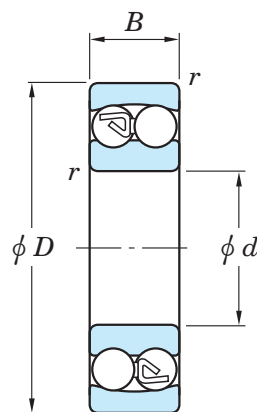

Cylindrical bore

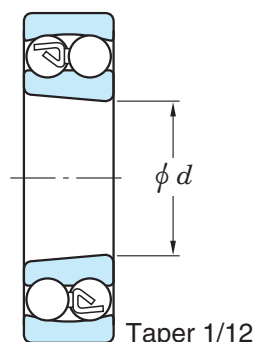

Tapered bore

Boundary dimensions (mm)				Basic load ratings (kN)		Limiting speeds (min ⁻¹)		Bearing No.	
d	D	B	r min.	C_r	C_{0r}	Grease lub.	Oil lub.	Cylindrical bore	Tapered bore
85	150	36	2	58.3	23.6	3 800	4 600	2217	2217K
	180	41	3	97.3	37.8	3 300	4 000	1317	1317K
	180	60	3	141	51.5	3 000	4 100	2317	2317K
90	160	30	2	56.8	23.4	3 500	4 300	1218	1218K
	160	40	2	67.7	27.2	3 500	4 300	2218	2218K
	190	43	3	116	44.4	3 100	3 800	1318	1318K
	190	64	3	153	57.9	2 800	3 900	2318	2318K
95	170	32	2.1	57.0	24.3	3 300	4 000	1219	1219K
	170	43	2.1	82.7	34.3	3 300	4 000	2219	2219K
	200	45	3	132	50.8	2 900	3 600	1319	1319K
	200	67	3	166	64.8	2 700	3 700	2319	2319K
100	180	34	2.1	69.0	29.7	3 100	3 800	1220	1220K
	180	46	2.1	80.9	34.0	3 100	3 800	2220	2220K
	215	47	3	143	57.3	2 800	3 400	1320	1320K
	215	73	3	183	73.4	2 400	3 400	2320	2320K
105	190	36	2.1	77.0	34.0	2 900	3 600	1221	—
	190	50	2.1	94.9	40.1	3 000	3 600	2221	—
	225	49	3	149	60.2	2 600	3 200	1321	—
	225	77	3	187	78.0	2 300	3 200	2321	—
110	200	38	2.1	80.2	35.2	2 800	3 400	1222	1222K
	200	53	2.1	120	48.9	2 800	3 400	2222	2222K
	240	50	3	150	63.2	2 400	3 000	1322	1322K
	240	80	3	200	85.7	2 200	3 000	2322	2322K

[Remark] Standard cage types used for the above bearings are described earlier in this section.

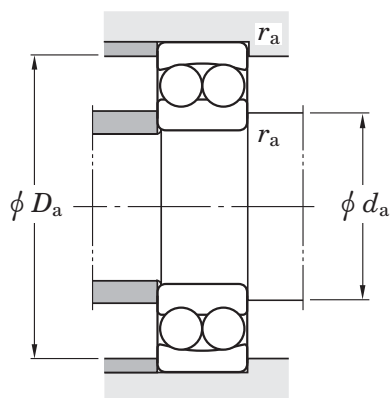

[Note] Protruding distance of balls

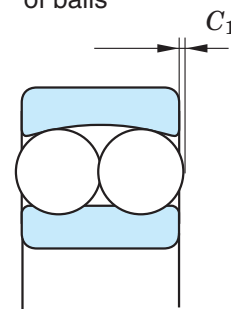

Balls of the following bearing protrude by C_1 from the bearing side.

	Mounting dimensions (mm)			Con- stant e	Axial load factors			(Refer.) Mass (kg)	
	d_a min.	D_a max.	r_a max.		Y_1	Y_2	Y_0	Cylindrical bore	Tapered bore
	94	141	2	0.25	2.49	3.85	2.61	2.52	2.46
	98	167	2.5	0.22	2.93	4.53	3.07	4.98	4.91
	98	167	2.5	0.35	1.82	2.82	1.91	7.05	6.89
	99	151	2	0.17	3.69	5.70	3.86	2.52	2.48
	99	151	2	0.26	2.39	3.71	2.51	3.40	3.33
	103	177	2.5	0.22	2.81	4.35	2.94	5.80	5.71
	103	177	2.5	0.34	1.84	2.85	1.93	8.44	8.25
	106	159	2	0.17	3.63	5.62	3.80	3.10	3.05
	106	159	2	0.26	2.43	3.76	2.55	4.10	4.00
	108	187	2.5	0.23	2.73	4.23	2.86	6.69	6.59
	108	187	2.5	0.35	1.82	2.82	1.91	9.79	9.57
	111	169	2	0.17	3.62	5.60	3.79	3.70	3.64
	111	169	2	0.24	2.57	3.98	2.70	4.98	4.87
	113	202	2.5	0.24	2.66	4.11	2.78	8.30	8.19
	113	202	2.5	0.34	1.84	2.85	1.93	12.4	12.1
	116	179	2	0.18	3.56	5.51	3.73	4.37	—
	116	179	2	0.26	2.43	3.76	2.55	6.07	—
	118	212	2.5	0.23	2.73	4.22	2.86	10.0	—
	118	212	2.5	0.36	1.75	2.71	1.83	14.3	—
	121	189	2	0.17	3.64	5.63	3.81	5.15	5.07
	121	189	2	0.26	2.41	3.73	2.53	7.10	6.94
	123	227	2.5	0.22	2.82	4.37	2.96	11.8	11.7
	123	227	2.5	0.35	1.82	2.82	1.91	17.3	16.9

Bearing No.	C_1 (mm)
1319	1.6
1320	2.5
1321	2.5 (approx.)
1322	2.6

Self-aligning ball bearings sealed type

d 10 ~ 55 mm

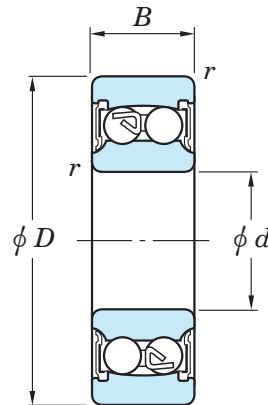

Boundary dimensions (mm)				Basic load ratings (kN)		Limiting speed (min ⁻¹) Grease lub.	Bearing No.
d	D	B	$r_{\text{min.}}$	C_r	C_{0r}		
10	30	14	0.6	5.40	1.20	15 000	2200 2RS 2300 2RS
	35	17	0.6	7.25	1.60	13 000	
12	32	14	0.6	5.60	1.25	14 000	2201 2RS 2301 2RS
	37	17	1	9.40	2.15	12 000	
15	35	14	0.6	7.45	1.75	12 000	2202 2RS 2302 2RS
	42	17	1	9.55	2.30	11 000	
17	40	16	0.6	7.90	2.00	11 000	2203 2RS 2303 2RS
	47	19	1	12.5	3.20	9 400	
20	47	18	1	9.90	2.60	9 100	2204 2RS 2304 2RS
	52	21	1.1	12.4	3.35	8 300	
25	52	18	1	12.1	3.30	7 900	2205 2RS 2305 2RS
	62	24	1.1	17.6	4.95	6 600	
30	62	20	1	15.6	4.65	6 600	2206 2RS 2306 2RS
	72	27	1.1	21.3	6.30	5 800	
35	72	23	1.1	15.8	5.10	5 700	2207 2RS 2307 2RS
	80	31	1.5	25.1	7.85	5 100	
40	80	23	1.1	19.2	6.50	5 000	2208 2RS 2308 2RS
	90	33	1.5	29.5	9.70	4 600	
45	85	23	1.1	21.8	7.35	4 600	2209 2RS 2309 2RS
	100	36	1.5	38.1	12.7	4 100	
50	90	23	1.1	22.7	8.10	4 300	2210 2RS 2310 2RS
	110	40	2	43.4	14.1	3 700	
55	100	25	1.5	26.8	10.0	3 900	2211 2RS 2311 2RS
	120	43	2	51.3	17.9	3 400	

[Remark] Standard cage types used for the above bearings are described earlier in this section.

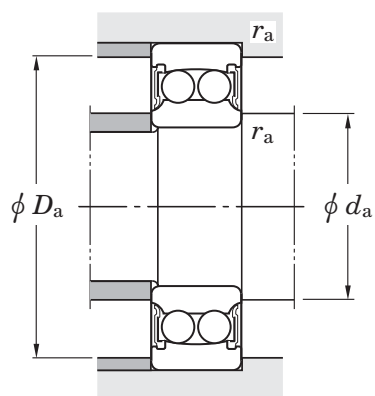

	Mounting dimensions (mm)				Con- stant <i>e</i>	Axial load factors			(Refer.) Mass (kg)
	min. <i>d_a</i>	max.	max. <i>D_a</i>	max. <i>r_a</i>		<i>Y</i> ₁	<i>Y</i> ₂	<i>Y</i> ₀	
	13.7	13.7	25	0.6	0.33	1.92	2.97	2.01	0.047
	15	15.7	30	0.6	0.34	1.85	2.87	1.94	0.085
	15.2	15.2	27	0.6	0.33	1.89	2.93	1.98	0.053
	16.8	16.8	31	1	0.36	1.77	2.74	1.86	0.095
	18.0	18.0	30	0.6	0.33	1.90	2.95	2.00	0.060
	20.0	20.0	36	1	0.34	1.86	2.88	1.95	0.114
	20.2	20.2	35	0.6	0.31	2.03	3.14	2.12	0.088
	22.1	22.1	41	1	0.33	1.92	2.97	2.01	0.158
	24.1	24.1	41	1	0.29	2.16	3.35	2.27	0.140
	26.2	26.2	45	1	0.30	2.12	3.28	2.22	0.209
	29.4	29.4	46	1	0.28	2.28	3.52	2.39	0.163
	32	33.9	55	1	0.27	2.31	3.57	2.42	0.335
	35.5	35.5	56	1	0.25	2.55	3.94	2.67	0.260
	37	37.8	65	1	0.26	2.40	3.72	2.52	0.500
	40.9	40.9	65	1	0.23	2.71	4.20	2.84	0.403
	43.5	45.0	71.5	1.5	0.25	2.48	3.84	2.60	0.675
	47	48.1	73	1	0.22	2.83	4.38	2.97	0.505
	48.5	49.6	81.5	1.5	0.25	2.57	3.98	2.69	0.925
	52	52.4	78	1	0.21	2.94	4.56	3.09	0.545
	53.5	56.6	91.5	1.5	0.25	2.56	3.95	2.68	1.23
	56.5	56.5	83	1	0.21	3.07	4.76	3.22	0.590
	60	62.5	100	2	0.23	2.70	4.17	2.83	1.64
	63.5	63.5	91.5	1.5	0.20	3.19	4.94	3.34	0.810
	65	65	110	2	0.23	2.70	4.18	2.83	2.10

Self-aligning ball bearings sealed type

d 60 ~ 110 mm

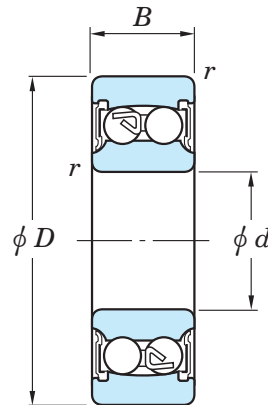

Boundary dimensions (mm)				Basic load ratings (kN)		Limiting speed (min ⁻¹) Grease lub.	Bearing No.
d	D	B	$r_{\text{min.}}$	C_r	C_{0r}		
60	110	28	1.5	30.2	11.5	3 500	2212 2RS 2312 2RS
	130	46	2.1	57.1	20.8	3 000	
65	120	31	1.5	31.0	12.5	3 200	2213 2RS 2313 2RS
	140	48	2.1	62.1	22.9	2 900	
70	125	31	1.5	34.6	13.8	3 100	2214 2RS 2314 2RS
	150	51	2.1	74.1	27.7	2 600	
75	130	31	1.5	38.8	15.7	2 900	2215 2RS 2315 2RS
	160	55	2.1	81.8	30.5	2 600	
80	140	33	2	39.8	17.0	2 700	2216 2RS 2316 2RS
	170	58	2.1	88.4	33.1	2 300	
85	150	36	2	49.2	20.8	2 500	2217 2RS
90	160	40	2	54.1	23.1	2 400	2218 2RS
95	170	43	2.1	60.8	26.8	2 200	2219 2RS
100	180	46	2.1	69.0	29.7	2 100	2220 2RS
105	190	50	2.1	77.0	34.0	2 000	2221 2RS
110	200	53	2.1	80.2	35.2	1 900	2222 2RS

[Remark] Standard cage types used for the above bearings are described earlier in this section.

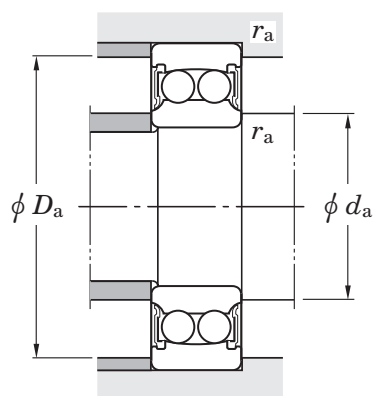

	Mounting dimensions (mm)				Con- stant <i>e</i>	Axial load factors			(Refer.) Mass (kg)
	min. <i>d_a</i>	max. <i>d_a</i>	max. <i>D_a</i>	max. <i>r_a</i>		<i>Y</i> ₁	<i>Y</i> ₂	<i>Y</i> ₀	
	68.5	68.5	101.5	1.5	0.19	3.37	5.22	3.53	1.09
	72	72	118	2	0.22	2.91	4.50	3.05	2.60
	73.5	75.5	111.5	1.5	0.17	3.67	5.68	3.84	1.46
	77	77	128	2	0.23	2.73	4.23	2.86	3.23
	78.5	78.5	116.5	1.5	0.18	3.48	5.38	3.64	1.52
	82	82	138	2	0.22	2.84	4.40	2.98	4.23
	83.5	83.5	121.5	1.5	0.17	3.60	5.58	3.77	1.62
	87	87	148	2	0.23	2.80	4.33	2.93	5.13
	90	90	130	2	0.16	3.90	6.03	4.08	2.01
	92	92	158	2	0.22	2.90	4.49	3.04	6.10
	95	95	140	2	0.17	3.61	5.59	3.78	2.52
	100	100	150	2	0.17	3.69	5.70	3.86	3.40
	107	107	158	2	0.17	3.63	5.62	3.80	4.10
	112	112	168	2	0.17	3.62	5.60	3.79	4.98
	117	117	178	2	0.18	3.56	5.51	3.73	6.07
	122	122	188	2	0.17	3.64	5.63	3.81	7.10

Self-aligning ball bearings extended inner ring type

d 20 ~ 60 mm

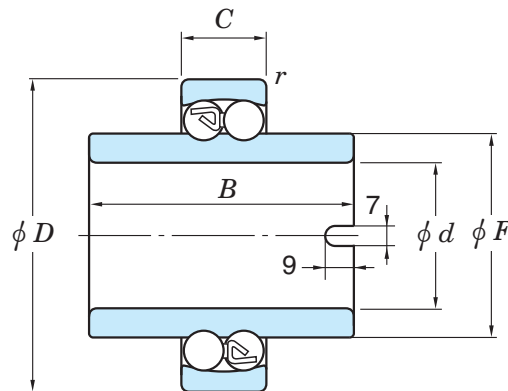

Boundary dimensions (mm)						Basic load ratings (kN)		Limiting speeds (min ⁻¹)		Bearing No.
d	D	B	C	F	$r_{\text{min.}}$	C_r	C_{0r}	Grease lub.	Oil lub.	
20	47	40	14	29.2	1	9.90	2.60	14 000	17 000	11204
	52	44	15	31.5	1.1	12.4	3.35	13 000	15 000	11304
25	52	44	15	33.3	1	12.1	3.30	12 000	14 000	11205
	62	48	17	38	1.1	17.6	4.95	9 900	12 000	11305
30	62	48	16	40.1	1	15.6	4.65	9 900	12 000	11206
	72	52	19	45	1.1	21.3	6.30	8 700	11 000	11306
35	72	52	17	47.7	1.1	15.8	5.10	8 500	10 000	11207
	80	56	21	51.7	1.5	25.1	7.85	7 600	9 300	11307
40	80	56	18	54	1.1	19.2	6.50	7 500	9 200	11208
	90	58	23	57.7	1.5	29.5	9.70	6 900	8 400	11308
45	85	58	19	57.7	1.1	21.8	7.35	7 000	8 500	11209
	100	60	25	63.9	1.5	38.1	12.7	6 100	7 500	11309
50	90	58	20	62.7	1.1	22.7	8.10	6 500	7 900	11210
	110	62	27	70.3	2	43.4	14.1	5 600	6 800	11310
55	100	60	21	70.3	1.5	26.8	10.0	5 800	7 100	11211
60	110	62	22	78	1.5	30.2	11.5	5 200	6 400	11212

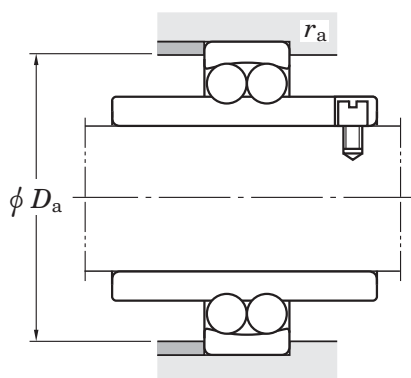

	Mounting dimensions (mm)		Con- stant <i>e</i>	Axial load factors			(Refer.) Mass (kg)
	<i>D_a</i> max.	<i>r_a</i> max.		<i>Y₁</i>	<i>Y₂</i>	<i>Y₀</i>	
	42	1	0.29	2.16	3.35	2.27	0.191
	45.5	1	0.30	2.12	3.28	2.22	0.266
	47	1	0.28	2.28	3.52	2.39	0.226
	55.5	1	0.27	2.31	3.57	2.42	0.445
	57	1	0.25	2.55	3.94	2.67	0.360
	65.5	1	0.26	2.40	3.72	2.52	0.614
	65.5	1	0.23	2.71	4.20	2.84	0.556
	72	1.5	0.25	2.48	3.84	2.60	0.821
	73.5	1	0.22	2.83	4.38	2.97	0.733
	82	1.5	0.25	2.57	3.98	2.69	1.09
	78.5	1	0.21	2.94	4.56	3.09	0.793
	92	1.5	0.25	2.56	3.95	2.68	1.40
	83.5	1	0.21	3.07	4.76	3.22	0.875
	102	2	0.23	2.70	4.17	2.83	1.74
	93.5	1.5	0.20	3.19	4.94	3.34	1.16
	103.5	1.5	0.19	3.37	5.22	3.53	1.52

Adapter assemblies for self-aligning ball bearings

d_1 17 ~ (45) mm

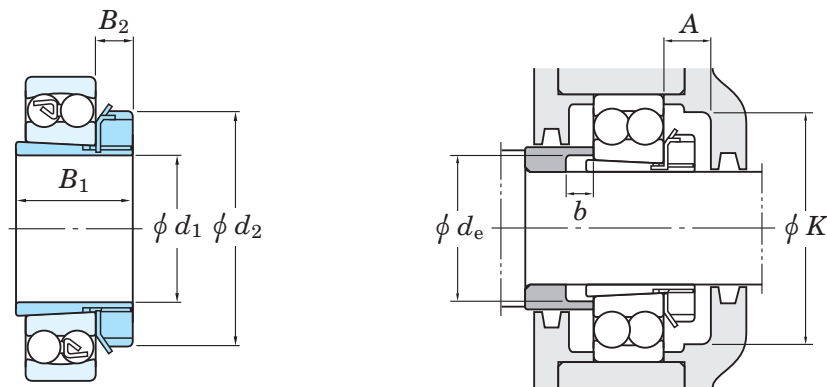

Boundary dimensions (mm)				Brg. bore d (mm)	Designations Bearing + adapter ass'y	Mounting dimensions (mm)				Mass Brg.+adapter ass'y (kg)	(Refer.)	
d_1	B_1	d_2	B_2			A min.	K min.	d_e min.	b min.		Adapter sleeve No.	Locknut No.
17	24	32	7	20	1204K+H204X	—	—	23	5	0.162	A204X	AN04
	28	32	7	20	2204K+H304X	—	—	24	5	0.185	A304X	AN04
	28	32	7	20	1304K+H304X	—	—	24	8	0.210	A304X	AN04
	31	32	7	20	2304K+H2304X	—	—	24	5	0.257	A2304X	AN04
20	26	38	8	25	1205K+H205X	15	45	28	5	0.218	A205X	AN05
	29	38	8	25	2205K+H305X	15	45	29	5	0.243	A305X	AN05
	29	38	8	25	1305K+H305X	15	45	29	6	0.337	A305X	AN05
	35	38	8	25	2305K+H2305X	15	45	29	5	0.424	A2305X	AN05
25	27	45	8	30	1206K+H206X	15	50	33	5	0.320	A206X	AN06
	31	45	8	30	2206K+H306X	15	50	34	5	0.368	A306X	AN06
	31	45	8	30	1306K+H306X	15	50	34	6	0.495	A306X	AN06
	38	45	8	30	2306K+H2306X	15	50	35	5	0.620	A2306X	AN06
30	29	52	9	35	1207K+H207X	17	58	38	5	0.462	A207X	AN07
	35	52	9	35	2207K+H307X	17	58	39	5	0.557	A307X	AN07
	35	52	9	35	1307K+H307X	17	58	39	7	0.663	A307X	AN07
	43	52	9	35	2307K+H2307X	17	58	40	5	0.843	A2307X	AN07
35	31	58	10	40	1208K+H208X	17	65	44	5	0.597	A208X	AN08
	36	58	10	40	2208K+H308X	17	65	44	5	0.696	A308X	AN08
	36	58	10	40	1308K+H308X	17	65	44	5	0.906	A308X	AN08
	46	58	10	40	2308K+H2308X	17	65	45	5	1.14	A2308X	AN08
40	33	65	11	45	1209K+H209X	17	72	49	5	0.701	A209X	AN09
	39	65	11	45	2209K+H309X	17	72	49	8	0.798	A309X	AN09
	39	65	11	45	1309K+H309X	17	72	49	5	1.21	A309X	AN09
	50	65	11	45	2309K+H2309X	17	72	50	5	1.51	A2309X	AN09
45	35	70	12	50	1210K+H210X	19	76	53	5	0.804	A210X	AN10
	42	70	12	50	2210K+H310X	19	76	54	10	0.896	A310X	AN10

d_1 (45) ~ 75 mm

Boundary dimensions (mm)				Brg. bore d (mm)	Designations Bearing + adapter ass'y	Mounting dimensions (mm)				Mass Brg.+adapter ass'y (kg)	(Refer.)	
d_1	B_1	d_2	B_2			A min.	K min.	d_e min.	b min.		Adapter sleeve No.	Locknut No.
45	42	70	12	50	1310K+ H310X	19	76	54	5	1.51	A310X	AN10
	55	70	12	50	2310K+ H2310X	19	76	56	5	1.98	A2310X	AN10
50	37	75	12	55	1211K+ H211X	19	85	60	6	1.02	A211X	AN11
	45	75	12	55	2211K+ H311X	19	85	60	11	1.16	A311X	AN11
	45	75	12	55	1311K+ H311X	19	85	60	6	1.93	A311X	AN11
	59	75	12	55	2311K+ H2311X	19	85	61	6	2.50	A2311X	AN11
55	38	80	13	60	1212K+ H212X	20	90	61	5	1.25	A212X	AN12
	47	80	13	60	2212K+ H312X	20	90	65	9	1.49	A312X	AN12
	47	80	13	60	1312K+ H312X	20	90	65	5	2.35	A312X	AN12
	62	80	13	60	2312K+ H2312X	20	90	66	5	3.04	A2312X	AN12
60	40	85	14	65	1213K+ H213X	21	96	70	5	1.56	A213X	AN13
	50	85	14	65	2213K+ H313X	21	96	70	8	1.92	A313X	AN13
	50	85	14	65	1313K+ H313X	21	96	70	5	2.90	A313X	AN13
	65	85	14	65	2313K+ H2313X	21	96	72	5	3.74	A2313X	AN13
65	43	98	15	75	1215K+ H215X	23	110	80	5	2.09	A215X	AN15
	55	98	15	75	2215K+ H315X	23	110	80	12	2.47	A315X	AN15
	55	98	15	75	1315K+ H315X	23	110	80	5	4.40	A315X	AN15
	73	98	15	75	2315K+ H2315X	23	110	82	5	6.12	A2315X	AN15
70	46	105	17	80	1216K+ H216X	25	120	85	5	2.57	A216X	AN16
	59	105	17	80	2216K+ H316X	25	120	86	12	3.06	A316X	AN16
	59	105	17	80	1316K+ H316X	25	120	86	5	5.21	A316X	AN16
	78	105	17	80	2316K+ H2316X	25	120	87	5	7.30	A2316X	AN16
75	50	110	18	85	1217K+ H217X	27	128	90	6	3.11	A217X	AN17
	63	110	18	85	2217K+ H317X	27	128	91	12	3.70	A317X	AN17
	63	110	18	85	1317K+ H317X	27	128	91	6	6.15	A317X	AN17
	82	110	18	85	2317K+ H2317X	27	128	94	6	8.41	A2317X	AN17

Adapter assemblies for self-aligning ball bearings

d_1 80 ~ 100 mm

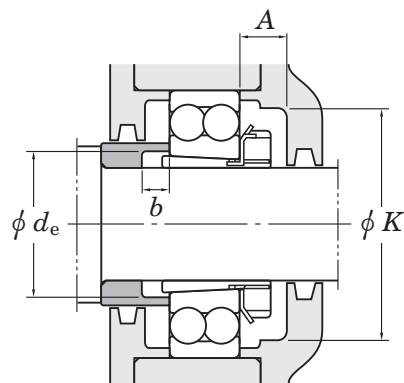
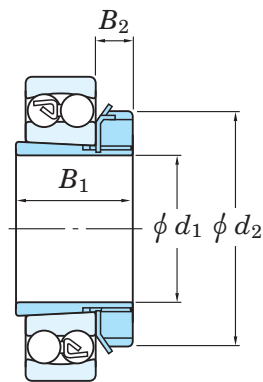

Boundary dimensions (mm)				Brg. bore d (mm)	Designations Bearing + adapter ass'y	Mounting dimensions (mm)				Mass Brg.+adapter ass'y (kg)	(Refer.)	
d_1	B_1	d_2	B_2			A min.	K min.	d_e min.	b min.		Adapter sleeve No.	Locknut No.
80	52	120	18	90	1218K+ H218X	28	139	95	6	3.75	A218X	AN18
	65	120	18	90	2218K+ H318X	28	139	96	10	4.78	A318X	AN18
	65	120	18	90	1318K+ H318X	28	139	96	6	7.16	A318X	AN18
	86	120	18	90	2318K+ H2318X	28	139	99	6	9.95	A2318X	AN18
85	55	125	19	95	1219K+ H219X	29	145	101	7	4.47	A219X	AN19
	68	125	19	95	2219K+ H319X	29	145	102	9	5.62	A319X	AN19
	68	125	19	95	1319K+ H319X	29	145	102	7	8.21	A319X	AN19
	90	125	19	95	2319K+ H2319X	29	145	105	7	11.6	A2319X	AN19
90	58	130	20	100	1220K+ H220X	30	150	106	7	5.23	A220X	AN20
	71	130	20	100	2220K+ H320X	30	150	107	8	6.67	A320X	AN20
	71	130	20	100	1320K+ H320X	30	150	107	7	9.99	A320X	AN20
	97	130	20	100	2320K+ H2320X	30	150	110	7	14.4	A2320X	AN20
100	63	145	21	110	1222K+ H222X	32	170	116	7	7.10	A222X	AN22
	77	145	21	110	2222K+ H322X	32	170	117	6	9.23	A322X	AN22
	77	145	21	110	1322K+ H322X	32	170	117	9	14.0	A322X	AN22
	105	145	21	110	2322K+ H2322X	32	170	121	7	19.8	A2322X	AN22



KOYO



Cylindrical roller bearings

Cylindrical roller bearings feature high radial load capacity because the rollers and raceway are in linear contact. These bearings are suitable for applications that involve heavy radial and impact loading.

They are also appropriate for high-speed applications in that they can be machined very accurately due to their structure.

Having a separable inner ring or outer ring, these bearings can be mounted and dismounted easily.

Single-row cylindrical roller bearings

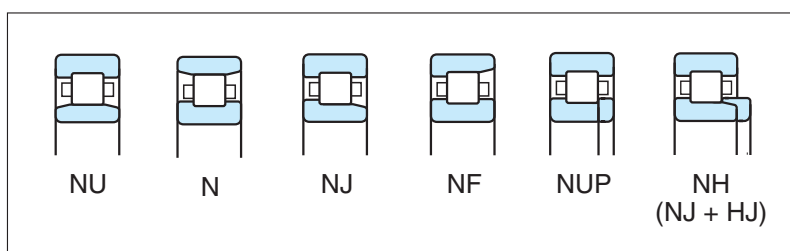

- The NU and N types exhibit their best performance when used as free side bearings since they adjust to the shaft's axial movement, to a certain extent, relative to the housing position.
- The NJ and NF types carry axial load in one direction, while the NUP and NH types can carry a certain degree of axial load in both directions.
- Type R cylindrical roller bearings feature enhanced load rating compared with standard series, though both have equal dimensions. This is because type R bearings have different internal design. They are identified by supplementary code "R".

Double-row cylindrical roller bearings

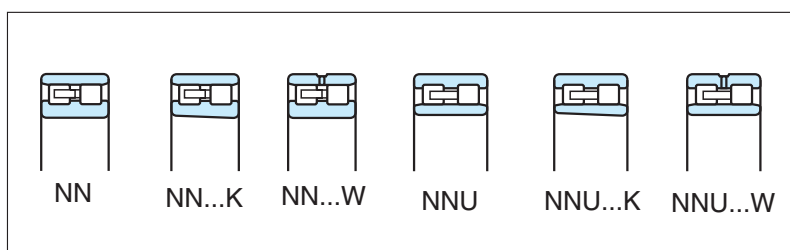

- Double-row cylindrical roller bearings come in two types : with a cylindrical bore, and with a tapered bore. As for those with a tapered bore, the specified amount of clearance can be obtained by adjusting the press-in distance. Some bearings have lubrication holes and lubrication grooves on the outer ring. They are identified by supplementary code "W".
- These bearings can accommodate high radial loads, and are often used on machine tool spindles.

Single-row cylindrical roller bearings



Bore diameter **20 – 460** mm

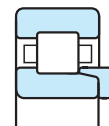

Thrust collar

Bore diameter **20 – 320** mm

Double-row cylindrical roller bearings

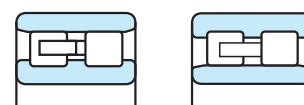

NN

NNU

Bore diameter **25 – 480** mm

Boundary dimensions	The dimensions of standard series are as specified in JIS B 1512.																																																												
Tolerances	As specified in JIS B 1514-1 (refer to Table 7-3 on pp. A 54 – A 57).																																																												
	<p>Tolerances of roller set bore diameter F_w and roller set outside diameter E_w of interchangeable bearings are as follows :</p> <p style="text-align: right;">Unit : μm</p> <table border="1" data-bbox="432 495 1401 987"> <thead> <tr> <th colspan="2">Nominal bore diameter d (mm)</th> <th colspan="2">Δ_{F_w} Roller set bore diameter deviation</th> <th colspan="2">Δ_{E_w} Roller set outside diameter deviation</th> </tr> <tr> <th>over</th> <th>up to</th> <th>upper</th> <th>lower</th> <th>upper</th> <th>lower</th> </tr> </thead> <tbody> <tr> <td>–</td> <td>20</td> <td>+ 10</td> <td>0</td> <td>0</td> <td>– 10</td> </tr> <tr> <td>20</td> <td>50</td> <td>+ 15</td> <td>0</td> <td>0</td> <td>– 15</td> </tr> <tr> <td>50</td> <td>120</td> <td>+ 20</td> <td>0</td> <td>0</td> <td>– 20</td> </tr> <tr> <td>120</td> <td>200</td> <td>+ 25</td> <td>0</td> <td>0</td> <td>– 25</td> </tr> <tr> <td>200</td> <td>250</td> <td>+ 30</td> <td>0</td> <td>0</td> <td>– 30</td> </tr> <tr> <td>250</td> <td>315</td> <td>+ 35</td> <td>0</td> <td>0</td> <td>– 35</td> </tr> <tr> <td>315</td> <td>400</td> <td>+ 40</td> <td>0</td> <td>0</td> <td>– 40</td> </tr> <tr> <td>400</td> <td>500</td> <td>+ 45</td> <td>0</td> <td>–</td> <td>–</td> </tr> </tbody> </table> <p>[Remark] Interchangeable bearings have an inner ring with rollers that can be matched with the outer ring, or an outer ring with rollers that can be matched with the inner ring, without affecting performance in the bearing that has the same bearing number in one category.</p>	Nominal bore diameter d (mm)		Δ_{F_w} Roller set bore diameter deviation		Δ_{E_w} Roller set outside diameter deviation		over	up to	upper	lower	upper	lower	–	20	+ 10	0	0	– 10	20	50	+ 15	0	0	– 15	50	120	+ 20	0	0	– 20	120	200	+ 25	0	0	– 25	200	250	+ 30	0	0	– 30	250	315	+ 35	0	0	– 35	315	400	+ 40	0	0	– 40	400	500	+ 45	0	–	–
	Nominal bore diameter d (mm)		Δ_{F_w} Roller set bore diameter deviation		Δ_{E_w} Roller set outside diameter deviation																																																								
over	up to	upper	lower	upper	lower																																																								
–	20	+ 10	0	0	– 10																																																								
20	50	+ 15	0	0	– 15																																																								
50	120	+ 20	0	0	– 20																																																								
120	200	+ 25	0	0	– 25																																																								
200	250	+ 30	0	0	– 30																																																								
250	315	+ 35	0	0	– 35																																																								
315	400	+ 40	0	0	– 40																																																								
400	500	+ 45	0	–	–																																																								
Tapered bore tolerance and allowable values of high precision double-row cylindrical roller bearings (classes 5 and 4) are provided in JTEKT standards (refer to Table 7-11 on p. A 70).																																																													
Radial internal clearance	<ul style="list-style-type: none"> · Cylindrical bore and tapered bore bearings(refer to Table 10-8 on pp. A 100, 101.) · Motor bearings.....(refer to Table 10-7 on p. A 99.) 																																																												
Recommended fits	Refer to Table 9-4 on pp. A 85, 86.																																																												
Standard cages	<ul style="list-style-type: none"> ■ For single-row cylindrical roller bearings : <ul style="list-style-type: none"> · Pressed steel cage (supplementary code : //) · Copper alloy machined cage (supplementary code : FY) } For application range, refer to Table 1. (Copper alloy machined cages without rivets (LY) are also used for some special purposes.) ■ For double-row cylindrical roller bearings : <ul style="list-style-type: none"> · Prong type copper alloy machined cage (supplementary code : FY) · Separable prong type copper alloy machined cage (supplementary code : FW)for class 5 or higher precision bearings 																																																												

Allowable misalignment	<p>Allowable misalignment of single-row cylindrical roller bearings depends on bearing type and specification.</p> <p>General values are as follows :</p> <p>1) When P_r / C_r is approx. 10% under load of normal use 0.000 6 rad (2') – 0.000 9 rad (3')</p> <p>2) When P_r / C_r is approx. 6% under load lighter than 1) 0.001 2 rad (4')</p> <p>When very large allowable misalignment is required, consult with JTEKT.</p>
Equivalent radial load	<p>Dynamic equivalent radial load $P_r = F_r$</p> <p>Static equivalent radial load $P_{0r} = F_r$</p>
Allowable axial load	<p>Cylindrical roller bearings with ribs, including loose rib and thrust collar, on both inner and outer rings accommodate axial load to a certain extent. (NJ and NF types accommodate load applied in one direction : NUP and NH in both directions.)</p> <p>For calculation of allowable axial load, refer to p. A 40.</p>

Table 1 Application of standard cages

Bearing series	Pressed cage	Machined cage
NU, NUP 10	—	1005 – 1092
NU, NJ, NUP, NF 2	204 – 220	204 – 264
NU, NJ, NUP 2 R	204R – 220R	204R – 240R
NU, NJ, NUP 22	2204 – 2220	2204 – 2252
NU, NJ, NUP 22 R	2204R – 2220R	2204R – 2240R
NU 32	—	3206 – 3252
NU, NJ, NUP, NF 3	304 – 320	304 – 348
NU, NJ, NUP 3 R	304R – 320R	304R – 332R
NU, NJ, NUP 23	2304 – 2320	2304 – 2340
NU, NJ, NUP 23 R	2304R – 2320R	2304R – 2332R
NU 33	—	3306 – 3352
NU, NJ, NUP, NF 4	406 – 420	406 – 430

Single-row cylindrical roller bearings

d 20 ~ (30) mm

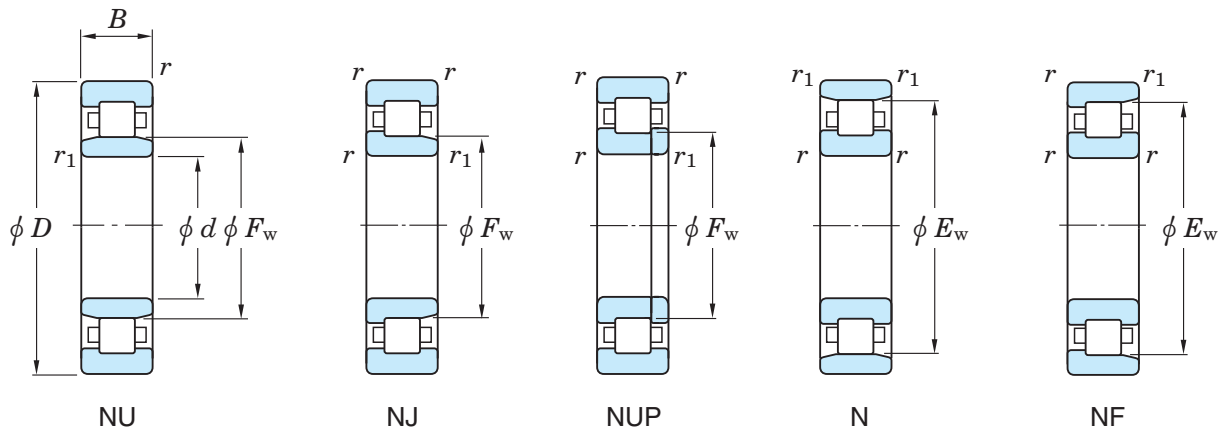

Boundary dimensions (mm)							Basic load ratings (kN)		Limiting speeds (min ⁻¹)		Bearing No.	
d	D	B	r min.	r_1 min.	F_w	E_w	C_r	C_{Or}	Grease lub.	Oil lub.	NU	NJ
20	47	14	1	0.6	27	40	15.4	12.7	15 000	18 000	NU204	NJ204
	47	14	1	0.6	26.5	—	25.7	22.6	15 000	18 000	NU204R	NJ204R
	47	18	1	0.6	27	—	20.7	18.4	13 000	18 000	NU2204	NJ2204
	47	18	1	0.6	26.5	—	30.6	28.3	13 000	18 000	NU2204R	NJ2204R
	52	15	1.1	0.6	28.5	44.5	23.1	19.2	12 000	16 000	NU304	NJ304
	52	15	1.1	0.6	27.5	—	31.5	26.9	12 000	16 000	NU304R	NJ304R
	52	21	1.1	0.6	28.5	—	32.9	30.2	11 000	16 000	NU2304	NJ2304
	52	21	1.1	0.6	27.5	—	42.0	38.8	11 000	16 000	NU2304R	NJ2304R
25	47	12	0.6	0.3	30.5	—	14.3	13.1	15 000	18 000	NU1005	—
	52	15	1	0.6	32	45	17.7	15.7	13 000	16 000	NU205	NJ205
	52	15	1	0.6	31.5	—	29.3	27.7	13 000	15 000	NU205R	NJ205R
	52	18	1	0.6	32	—	23.7	22.8	12 000	16 000	NU2205	NJ2205
	52	18	1	0.6	31.5	—	34.9	34.6	12 000	15 000	NU2205R	NJ2205R
	62	17	1.1	1.1	35	53	29.3	25.2	10 000	14 000	NU305	NJ305
	62	17	1.1	1.1	34	—	41.6	37.4	10 000	14 000	NU305R	NJ305R
	62	24	1.1	1.1	35	—	42.7	40.9	9 100	14 000	NU2305	NJ2305
62	24	1.1	1.1	34	—	57.0	56.1	9 100	14 000	NU2305R	NJ2305R	
30	55	13	1	0.6	36.5	—	18.7	18.4	13 000	15 000	NU1006	—
	62	16	1	0.6	38.5	53.5	23.5	21.5	11 000	13 000	NU206	NJ206
	62	16	1	0.6	37.5	—	39.1	37.4	11 000	13 000	NU206R	NJ206R
	62	20	1	0.6	38.5	—	32.9	33.1	9 800	13 000	NU2206	NJ2206
	62	20	1	0.6	37.5	—	48.9	49.8	9 700	13 000	NU2206R	NJ2206R
	62	23.8	1	1	38.5	—	42.7	46.4	8 700	13 000	NU3206	—
	72	19	1.1	1.1	42	62	38.6	35.2	8 700	12 000	NU306	NJ306
	72	19	1.1	1.1	40.5	—	53.1	50.2	8 700	12 000	NU306R	NJ306R
	72	27	1.1	1.1	42	—	51.4	50.8	7 700	12 000	NU2306	NJ2306
	72	27	1.1	1.1	40.5	—	74.6	77.6	7 800	12 000	NU2306R	NJ2306R

[Remarks] 1) Standard cage types used for the above bearings are shown in Table 1 earlier in this section. Please note that basic load ratings and limiting speeds shown above indicate the value applicable to machined cage. Consult JTEKT about bearings with pressed cage, since they may be different from bearings with machined cage in values above.

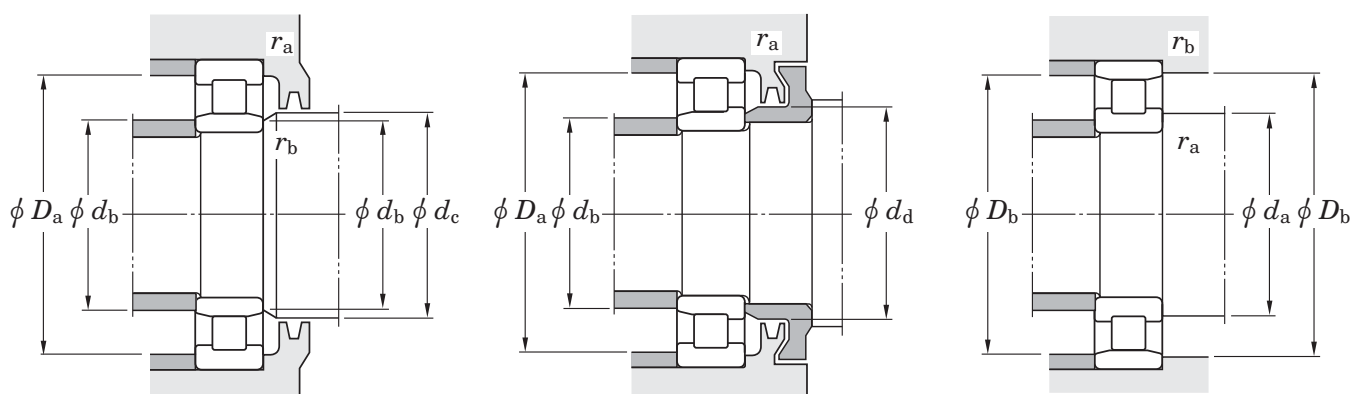

NUP	N	NF	Mounting dimensions (mm)										(Refer.) Mass NU (kg)
			d_a min.	d_b min. max.	d_c min.	d_d min.	D_a max.	D_b max. min.	r_a max.	r_b max.			
NUP204	N204	NF204	25	24 26	29	32	42	43	42	1	0.6	0.108	
NUP204R	—	—	25	24 26	29	32	42	—	—	1	0.6	0.112	
NUP2204	—	—	25	24 26	29	32	42	—	—	1	0.6	0.146	
NUP2204R	—	—	25	24 26	29	32	42	—	—	1	0.6	0.146	
NUP304	N304	NF304	26.5	24 27	30	33	45.5	48	45.5	1	0.6	0.147	
NUP304R	—	—	26.5	24 27	30	33	45.5	—	—	1	0.6	0.153	
NUP2304	—	—	26.5	24 27	30	33	45.5	—	—	1	0.6	0.212	
NUP2304R	—	—	26.5	24 27	30	33	45.5	—	—	1	1	0.215	
NUP1005	—	—	29	27 30	32	—	43	—	—	0.6	0.3	0.084	
NUP205	N205	NF205	30	29 31	34	37	47	48	47	1	0.6	0.132	
NUP205R	—	—	30	29 31	34	37	47	—	—	1	0.6	0.138	
NUP2205	—	—	30	29 31	34	37	47	—	—	1	0.6	0.163	
NUP2205R	—	—	30	29 31	34	37	47	—	—	1	0.6	0.166	
NUP305	N305	NF305	31.5	31.5 33	37	40	55.5	55.5	55	1	1	0.241	
NUP305R	—	—	31.5	31.5 33	37	40	55.5	—	—	1	1	0.243	
NUP2305	—	—	31.5	31.5 33	37	40	55.5	—	—	1	1	0.340	
NUP2305R	—	—	31.5	31.5 33	37	40	55.5	—	—	1	1	0.350	
NUP1006	—	—	35	34 35	38	—	50	—	—	1	0.6	0.121	
NUP206	N206	NF206	35	34 37	40	44	57	58	56	1	0.6	0.200	
NUP206R	—	—	35	34 37	40	44	57	—	—	1	0.6	0.209	
NUP2206	—	—	35	34 37	40	44	57	—	—	1	0.6	0.262	
NUP2206R	—	—	35	34 37	40	44	57	—	—	1	0.6	0.262	
—	—	—	35	35 37	40	—	57	—	—	1	0.6	0.343	
NUP306	N306	NF306	36.5	36.5 40	44	48	65.5	65.5	64	1	1	0.358	
NUP306R	—	—	36.5	36.5 40	44	48	65.5	—	—	1	1	0.361	
NUP2306	—	—	36.5	36.5 40	44	48	65.5	—	—	1	1	0.500	
NUP2306R	—	—	36.5	36.5 40	44	48	65.5	—	—	1	1	0.534	

2) Bearing numbers of NU and NJ type bearings with mounted thrust collar (refer to specification table shown after this specification table) are NUJ and NH.

Single-row cylindrical roller bearings

d (30) ~ (45) mm

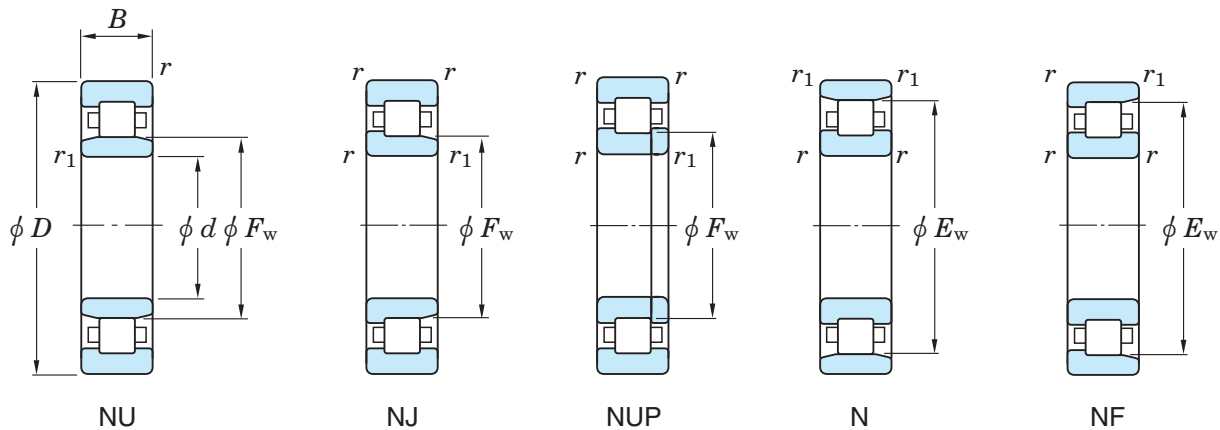

Boundary dimensions (mm)							Basic load ratings (kN)		Limiting speeds (min ⁻¹)		Bearing No.	
d	D	B	$r_{\min.}$	$r_{1\min.}$	F_w	E_w	C_r	C_{Or}	Grease lub.	Oil lub.	NU	NJ
30	72	30.2	1.1	1.1	42	—	69.1	74.3	7 700	12 000	NU3306	—
	90	23	1.5	1.5	45	73	62.8	55.0	7 600	10 000	NU406	NJ406
35	62	14	1	0.6	42	—	22.6	23.2	11 000	13 000	NU1007	—
	72	17	1.1	0.6	43.8	61.8	33.6	31.5	9 500	11 000	NU207	NJ207
	72	17	1.1	0.6	44	—	50.2	50.2	9 300	11 000	NU207R	NJ207R
	72	23	1.1	0.6	43.8	—	49.0	51.2	8 500	11 000	NU2207	NJ2207
	72	23	1.1	0.6	44	—	61.6	65.3	8 300	11 000	NU2207R	NJ2207R
	72	27	1.1	1.1	43.8	—	54.8	59.1	7 600	11 000	NU3207	—
	80	21	1.5	1.1	46.2	68.2	49.6	46.9	7 900	10 000	NU307	NJ307
	80	21	1.5	1.1	46.2	—	66.6	65.4	7 700	10 000	NU307R	NJ307R
	80	31	1.5	1.1	46.2	—	64.4	65.7	7 000	10 000	NU2307	NJ2307
	80	31	1.5	1.1	46.2	—	93.1	101	6 900	10 000	NU2307R	NJ2307R
	80	34.9	1.5	1.5	46.2	—	81.7	89.1	7 000	10 000	NU3307	—
	100	25	1.5	1.5	53	83	75.2	68.9	6 600	8 800	NU407	NJ407
40	68	15	1	0.6	47	—	24.9	25.7	10 000	12 000	NU1008	—
	80	18	1.1	1.1	50	70	43.8	42.9	8 300	10 000	NU208	NJ208
	80	18	1.1	1.1	49.5	—	55.7	55.4	8 300	9 900	NU208R	NJ208R
	80	23	1.1	1.1	50	—	58.3	62.0	7 500	10 000	NU2208	NJ2208
	80	23	1.1	1.1	49.5	—	72.3	77.6	7 400	9 900	NU2208R	NJ2208R
	80	30.2	1.1	1.1	50	—	78.3	90.6	6 700	10 000	NU3208	—
	90	23	1.5	1.5	53.5	77.5	58.6	56.9	6 900	9 100	NU308	NJ308
	90	23	1.5	1.5	52	—	83.1	81.5	6 800	9 100	NU308R	NJ308R
	90	33	1.5	1.5	53.5	—	82.2	88.0	6 100	9 100	NU2308	NJ2308
	90	33	1.5	1.5	52	—	114	122	6 100	9 100	NU2308R	NJ2308R
	90	36.5	1.5	1.5	53.5	—	104	119	6 100	9 100	NU3308	—
	110	27	2	2	58	92	97.1	89.1	6 000	8 000	NU408	NJ408
45	75	16	1	0.6	52.5	—	31.0	33.8	9 200	11 000	NU1009	—

[Remarks] 1) Standard cage types used for the above bearings are shown in Table 1 earlier in this section. Please note that basic load ratings and limiting speeds shown above indicate the value applicable to machined cage. Consult JTEKT about bearings with pressed cage, since they may be different from bearings with machined cage in values above.

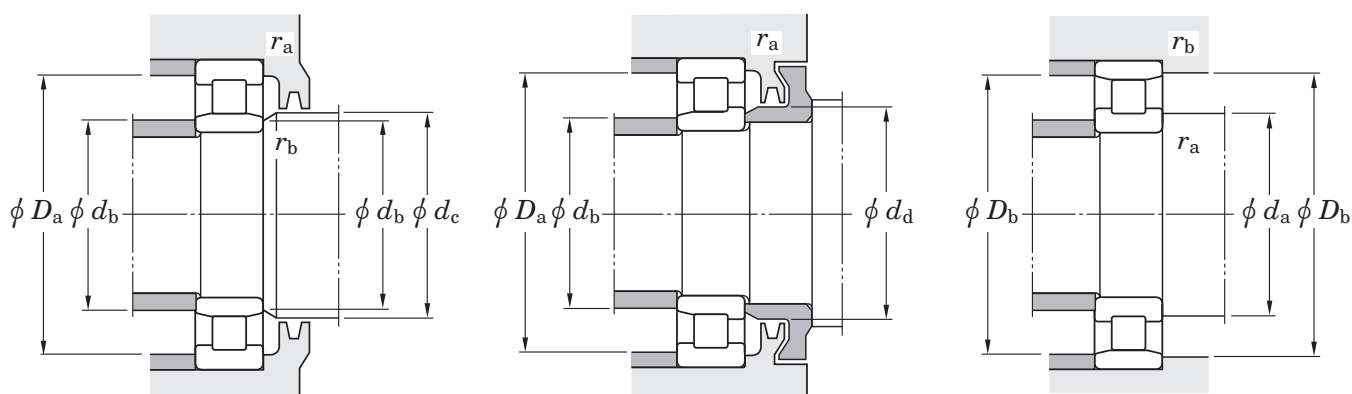

NUP	N	NF	Mounting dimensions (mm)										(Refer.) Mass NU (kg)
			d_a min.	d_b min. max.	d_c min.	d_d min.	D_a max.	D_b max. min.	r_a max.	r_b max.			
—	—	—	36.5	36.5 40	44	—	65.5	—	—	1	1	0.650	
NUP406	N406	NF406	38	38 44	47	52	82	82	74	1.5	1.5	0.753	
NUP1007	—	—	40	39 41	44	—	57	—	—	1	0.5	0.182	
NUP207	N207	NF207	41.5	39 43	46	50	65.5	68	64	1	0.6	0.293	
NUP207R	—	—	41.5	39 43	46	50	65.5	—	—	1	0.6	0.306	
NUP2207	—	—	41.5	39 43	46	50	65.5	—	—	1	0.6	0.402	
NUP2207R	—	—	41.5	39 43	46	50	65.5	—	—	1	0.6	0.404	
—	—	—	41.5	41.5 43	46	—	65.5	—	—	1	0.6	0.524	
NUP307	N307	NF307	43	41.5 45	48	53	72	73.5	71	1.5	1	0.477	
NUP307R	—	—	43	41.5 45	48	53	72	—	—	1.5	1	0.482	
NUP2307	—	—	43	41.5 45	48	53	72	—	—	1.5	1	0.696	
NUP2307R	—	—	43	41.5 45	48	53	72	—	—	1.5	1	0.729	
—	—	—	43	43 45	48	—	72	—	—	1.5	1	0.908	
NUP407	N407	NF407	43	43 52	55	61	92	92	84	1.5	1.5	1.02	
NUP1008	—	—	45	44 46	49	—	63	—	—	1	0.6	0.223	
NUP208	N208	NF208	46.5	46.5 49	52	56	73.5	73.5	72	1	1	0.366	
NUP208R	—	—	46.5	46.5 49	52	56	73.5	—	—	1	1	0.384	
NUP2208	—	—	46.5	46.5 49	52	56	73.5	—	—	1	1	0.490	
NUP2208R	—	—	46.5	46.5 49	52	56	73.5	—	—	1	1	0.490	
—	—	—	46.5	46.5 49	52	—	73.5	—	—	1	1	0.711	
NUP308	N308	NF308	48	48 51	55	60	82	82	80	1.5	1.5	0.657	
NUP308R	—	—	48	48 51	55	60	82	—	—	1.5	1.5	0.664	
NUP2308	—	—	48	48 51	55	60	82	—	—	1.5	1.5	0.956	
NUP2308R	—	—	48	48 51	55	60	82	—	—	1.5	1.5	0.962	
—	—	—	48	48 51	55	—	82	—	—	1.5	1.5	1.19	
NUP408	N408	NF408	49	49 57	60	67	101	101	93	2	2	1.30	
NUP1009	—	—	50	49 52	54	—	70	—	—	1	0.6	0.289	

2) Bearing numbers of NU and NJ type bearings with mounted thrust collar (refer to specification table shown after this specification table) are NUJ and NH.

Single-row cylindrical roller bearings

d (45) ~ (55) mm

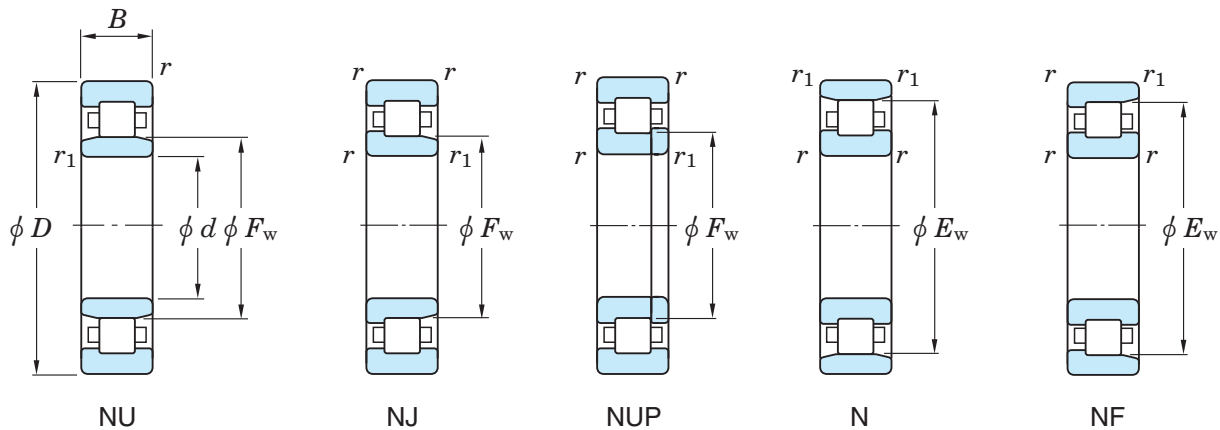

Boundary dimensions (mm)							Basic load ratings (kN)		Limiting speeds (min ⁻¹)		Bearing No.	
d	D	B	r min.	r_1 min.	F_w	E_w	C_r	C_{Or}	Grease lub.	Oil lub.	NU	NJ
45	85	19	1.1	1.1	55	75	46.1	46.9	7 700	9 200	NU209	NJ209
	85	19	1.1	1.1	54.5	—	63.1	66.4	7 600	9 200	NU209R	NJ209R
	85	23	1.1	1.1	55	—	61.4	67.8	6 900	9 200	NU2209	NJ2209
	85	23	1.1	1.1	54.5	—	76.1	84.6	6 900	9 200	NU2209R	NJ2209R
	85	30.2	1.1	1.1	55	—	82.4	99.0	6 100	9 200	NU3209	—
	100	25	1.5	1.5	58.5	86.5	78.8	77.5	6 200	8 300	NU309	NJ309
	100	25	1.5	1.5	58.5	—	97.4	98.3	6 100	8 200	NU309R	NJ309R
	100	36	1.5	1.5	58.5	—	106	113	5 500	8 300	NU2309	NJ2309
	100	36	1.5	1.5	58.5	—	137	153	5 400	8 200	NU2309R	NJ2309R
	100	39.7	1.5	1.5	58.5	—	131	149	5 500	8 300	NU3309	—
120	29	2	2	64.5	100.5	115	112	5 400	7 200	NU409	NJ409	
50	80	16	1	0.6	57.5	—	33.6	36.8	8 400	9 900	NU1010	—
	90	20	1.1	1.1	60.4	80.4	48.2	51.0	7 100	8 500	NU210	NJ210
	90	20	1.1	1.1	59.5	—	66.1	71.9	7 100	8 500	NU210R	NJ210R
	90	23	1.1	1.1	60.4	—	64.2	73.6	6 400	8 500	NU2210	NJ2210
	90	23	1.1	1.1	59.5	—	79.7	91.5	6 400	8 500	NU2210R	NJ2210R
	90	30.2	1.1	1.1	60.4	—	86.2	108	5 700	8 500	NU3210	—
	110	27	2	2	65	95	92.2	93.4	5 600	7 500	NU310	NJ310
	110	27	2	2	65	—	110	113	5 500	7 400	NU310R	NJ310R
	110	40	2	2	65	—	128	142	5 000	7 500	NU2310	NJ2310
	110	40	2	2	65	—	163	187	4 900	7 400	NU2310R	NJ2310R
	110	44.4	2	2	65	—	156	183	5 000	7 500	NU3310	—
130	31	2.1	2.1	70.8	110.8	139	136	4 900	6 600	NU410	NJ410	
55	90	18	1.1	1	64.5	—	37.4	43.8	7 600	8 900	NU1011	—
	100	21	1.5	1.1	66.5	88.5	58.0	62.3	6 400	7 700	NU211	NJ211
	100	21	1.5	1.1	66	—	86.4	98.7	6 400	7 700	NU211R	NJ211R
	100	25	1.5	1.1	66.5	—	75.3	87.2	5 800	7 700	NU2211	NJ2211

[Remarks] 1) Standard cage types used for the above bearings are shown in Table 1 earlier in this section. Please note that basic load ratings and limiting speeds shown above indicate the value applicable to machined cage. Consult JTEKT about bearings with pressed cage, since they may be different from bearings with machined cage in values above.

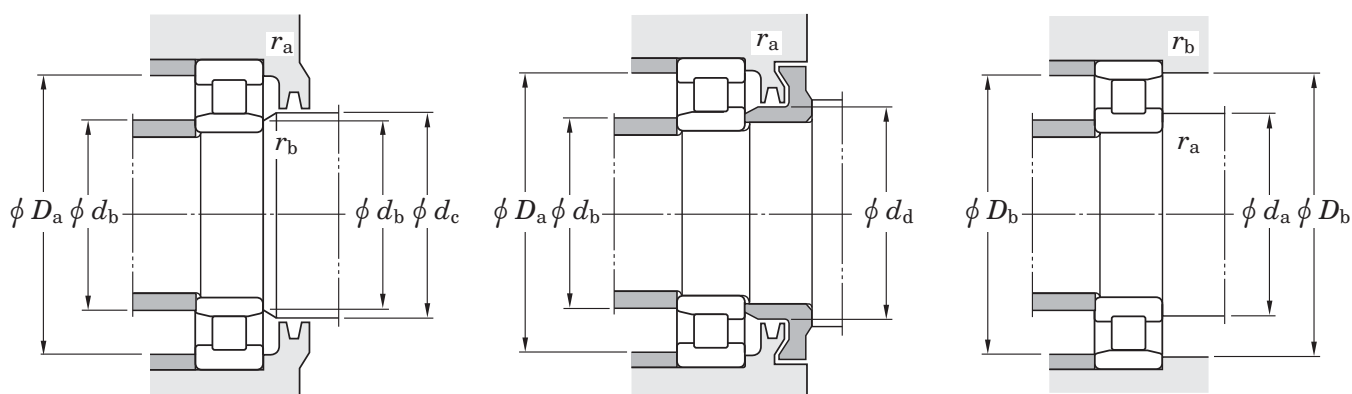

NUP	N	NF	Mounting dimensions (mm)										(Refer.)
			d_a min.	d_b min.	d_b max.	d_c min.	d_d min.	D_a max.	D_b max.	d_b min.	r_a max.	r_b max.	Mass NU (kg)
NUP209	N209	NF209	51.5	51.5	54	57	61	78.5	78.5	77	1	1	0.427
NUP209R	—	—	51.5	51.5	54	57	61	78.5	—	—	1	1	0.439
NUP2209	—	—	51.5	51.5	54	57	61	78.5	—	—	1	1	0.536
NUP2209R	—	—	51.5	51.5	54	57	61	78.5	—	—	1	1	0.536
—	—	—	51.5	51.5	54	57	—	78.5	—	—	1	1	0.770
NUP309	N309	NF309	53	53	57	60	66	92	92	89	1.5	1.5	0.870
NUP309R	—	—	53	53	57	60	66	92	—	—	1.5	1.5	0.909
NUP2309	—	—	53	53	57	60	66	92	—	—	1.5	1.5	1.25
NUP2309R	—	—	53	53	57	60	66	92	—	—	1.5	1.5	1.32
—	—	—	53	53	57	60	—	92	—	—	1.5	1.5	1.59
NUP409	N409	NF409	54	54	63	66	74	111	111	102	2	2	1.64
NUP1010	—	—	55	54	57	59	—	75	—	—	1	0.6	0.306
NUP210	N210	NF210	56.5	56.5	58	62	67	83.5	83.5	82	1	1	0.479
NUP210R	—	—	56.5	56.5	58	62	67	83.5	—	—	1	1	0.497
NUP2210	—	—	56.5	56.5	58	62	67	83.5	—	—	1	1	0.580
NUP2210R	—	—	56.5	56.5	58	62	67	83.5	—	—	1	1	0.580
—	—	—	56.5	56.5	58	62	—	83.5	—	—	1	1	0.829
NUP310	N310	NF310	59	59	63	67	73	101	101	98	2	2	1.15
NUP310R	—	—	59	59	63	67	73	101	—	—	2	2	1.15
NUP2310	—	—	59	59	63	67	73	101	—	—	2	2	1.69
NUP2310R	—	—	59	59	63	67	73	101	—	—	2	2	1.76
—	—	—	59	59	63	67	—	101	—	—	2	2	2.14
NUP410	N410	NF410	61	61	69	73	81	119	119	112	2	2	2.01
NUP1011	—	—	61.5	60	63	66	—	83.5	—	—	1	1	0.445
NUP211	N211	NF211	63	61.5	65	68	73	92	93.5	91	1.5	1	0.640
NUP211R	—	—	63	61.5	65	68	73	92	—	—	1.5	1	0.650
NUP2211	—	—	63	61.5	65	68	73	92	—	—	1.5	1	0.780

2) Bearing numbers of NU and NJ type bearings with mounted thrust collar (refer to specification table shown after this specification table) are NUJ and NH.

Single-row cylindrical roller bearings

d (55) ~ (65) mm

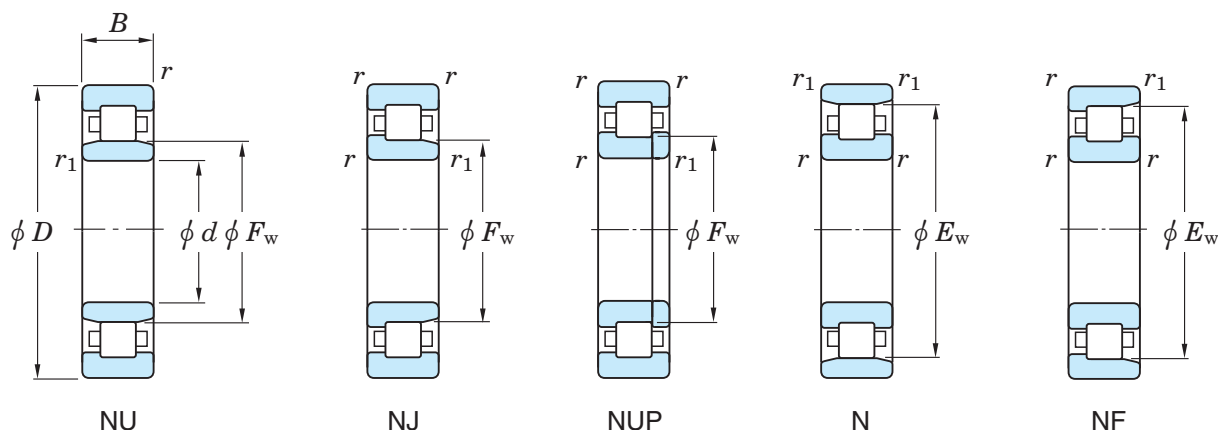

Boundary dimensions (mm)							Basic load ratings (kN)		Limiting speeds (min ⁻¹)		Bearing No.	
d	D	B	r min.	r_1 min.	F_w	E_w	C_r	C_{Or}	Grease lub.	Oil lub.	NU	NJ
55	100	25	1.5	1.1	66	—	101	122	5 800	7 700	NU2211R	NJ2211R
	100	33.3	1.5	1.5	66.5	—	95.5	118	5 100	7 700	NU3211	—
	120	29	2	2	70.5	104.5	111	111	5 100	6 800	NU311	NJ311
	120	29	2	2	70.5	—	137	143	5 100	6 700	NU311R	NJ311R
	120	43	2	2	70.5	—	148	162	4 500	6 800	NU2311	NJ2311
	120	43	2	2	70.5	—	201	233	4 500	6 700	NU2311R	NJ2311R
	120	49.2	2	2	70.5	—	188	220	4 500	6 800	NU3311	—
140	33	2.1	2.1	77.2	117.2	142	138	4 600	6 100	NU411	NJ411	
60	95	18	1.1	1	69.5	—	42.1	50.0	7 000	8 300	NU1012	—
	110	22	1.5	1.5	73.5	97.5	71.9	79.9	5 800	7 000	NU212	NJ212
	110	22	1.5	1.5	72	—	97.7	107	5 800	6 900	NU212R	NJ212R
	110	28	1.5	1.5	73.5	—	101	123	5 200	7 000	NU2212	NJ2212
	110	28	1.5	1.5	72	—	131	157	5 200	6 900	NU2212R	NJ2212R
	110	36.5	1.5	1.5	73.5	—	128	167	4 700	7 000	NU3212	—
	130	31	2.1	2.1	77	113	124	126	4 700	6 300	NU312	NJ312
	130	31	2.1	2.1	77	—	150	157	4 600	6 200	NU312R	NJ312R
	130	46	2.1	2.1	77	—	168	188	4 200	6 300	NU2312	NJ2312
	130	46	2.1	2.1	77	—	223	262	4 100	6 200	NU2312R	NJ2312R
	130	54	2.1	2.1	77	—	220	265	4 200	6 300	NU3312	—
150	35	2.1	2.1	83	127	178	184	4 200	5 700	NU412	NJ412	
65	100	18	1.1	1	74.5	—	43.3	52.9	6 600	7 800	NU1013	—
	120	23	1.5	1.5	79.6	105.6	83.8	94.4	5 400	6 400	NU213	NJ213
	120	23	1.5	1.5	78.5	—	108	119	5 300	6 400	NU213R	NJ213R
	120	31	1.5	1.5	79.6	—	120	149	4 800	6 400	NU2213	NJ2213
	120	31	1.5	1.5	78.5	—	149	181	4 800	6 400	NU2213R	NJ2213R
	120	38.1	1.5	1.5	79.6	—	148	197	4 300	6 400	NU3213	—
	140	33	2.1	2.1	83.5	121.5	137	139	4 300	5 800	NU313	NJ313

[Remarks] 1) Standard cage types used for the above bearings are shown in Table 1 earlier in this section. Please note that basic load ratings and limiting speeds shown above indicate the value applicable to machined cage. Consult JTEKT about bearings with pressed cage, since they may be different from bearings with machined cage in values above.

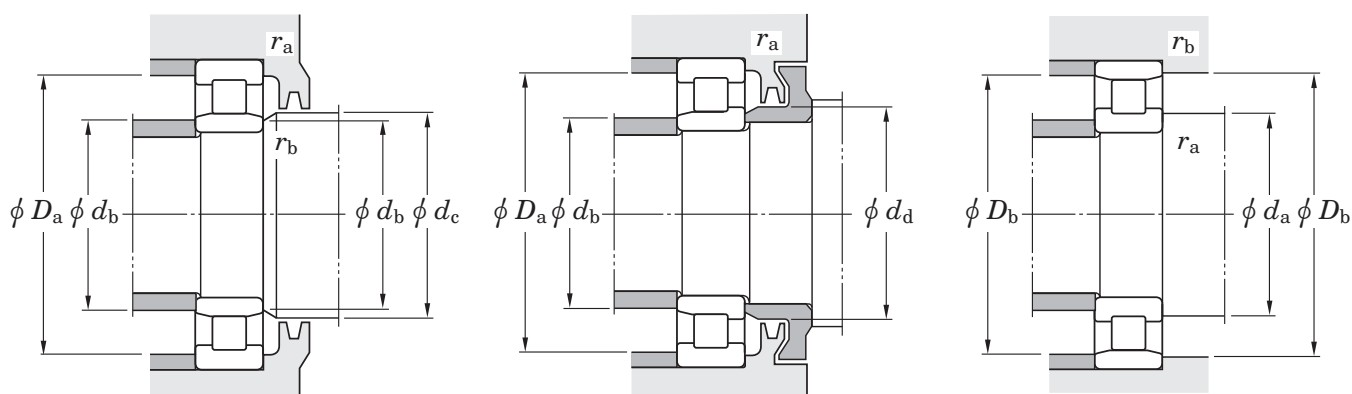

NUP	N	NF	Mounting dimensions (mm)										(Refer.) Mass NU (kg)
			d_a min.	d_b min. max.	d_c min.	d_d min.	D_a max.	D_b max. min.	r_a max.	r_b max.			
NUP2211R	—	—	63	61.5 65	68	73	92	—	—	1.5	1	0.806	
—	—	—	63	63 65	68	—	92	—	—	1.5	1	1.14	
NUP311	N311	NF311	64	64 69	72	80	111	111	107	2	2	1.44	
NUP311R	—	—	64	64 69	72	80	111	—	—	2	2	1.50	
NUP2311	—	—	64	64 69	72	80	111	—	—	2	2	2.10	
NUP2311R	—	—	64	64 69	72	80	111	—	—	2	2	2.25	
—	—	—	64	64 69	72	—	111	—	—	2	2	2.81	
NUP411	N411	NF411	66	66 76	79	87	129	129	119	2	2	2.51	
NUP1012	—	—	66.5	65 68	71	—	88.5	—	—	1	1	0.477	
NUP212	N212	NF212	68	68 71	75	80	102	102	100	1.5	1.5	0.823	
NUP212R	—	—	68	68 71	75	80	102	—	—	1.5	1.5	0.830	
NUP2212	—	—	68	68 71	75	80	102	—	—	1.5	1.5	1.07	
NUP2212R	—	—	68	68 71	75	80	102	—	—	1.5	1.5	1.09	
—	—	—	68	68 71	75	—	102	—	—	1.5	1.5	1.52	
NUP312	N312	NF312	71	71 75	79	86	119	119	116	2	2	1.83	
NUP312R	—	—	71	71 75	79	86	119	—	—	2	2	1.87	
NUP2312	—	—	71	71 75	79	86	119	—	—	2	2	2.69	
NUP2312R	—	—	71	71 75	79	86	119	—	—	2	2	2.81	
—	—	—	71	71 75	79	—	119	—	—	2	2	3.61	
NUP412	N412	NF412	71	71 82	85	94	139	139	128	2	2	3.02	
NUP1013	—	—	71.5	70 73	76	—	93.5	—	—	1	1	0.506	
NUP213	N213	NF213	73	73 77	81	87	112	112	108	1.5	1.5	1.05	
NUP213R	—	—	73	73 77	81	87	112	—	—	1.5	1.5	1.05	
NUP2213	—	—	73	73 77	81	87	112	—	—	1.5	1.5	1.43	
NUP2213R	—	—	73	73 77	81	87	112	—	—	1.5	1.5	1.45	
—	—	—	73	73 77	81	—	112	—	—	1.5	1.5	1.90	
NUP313	N313	NF313	76	76 81	85	93	129	129	125	2	2	2.24	

2) Bearing numbers of NU and NJ type bearings with mounted thrust collar (refer to specification table shown after this specification table) are NUJ and NH.

Single-row cylindrical roller bearings

d (65) ~ (75) mm

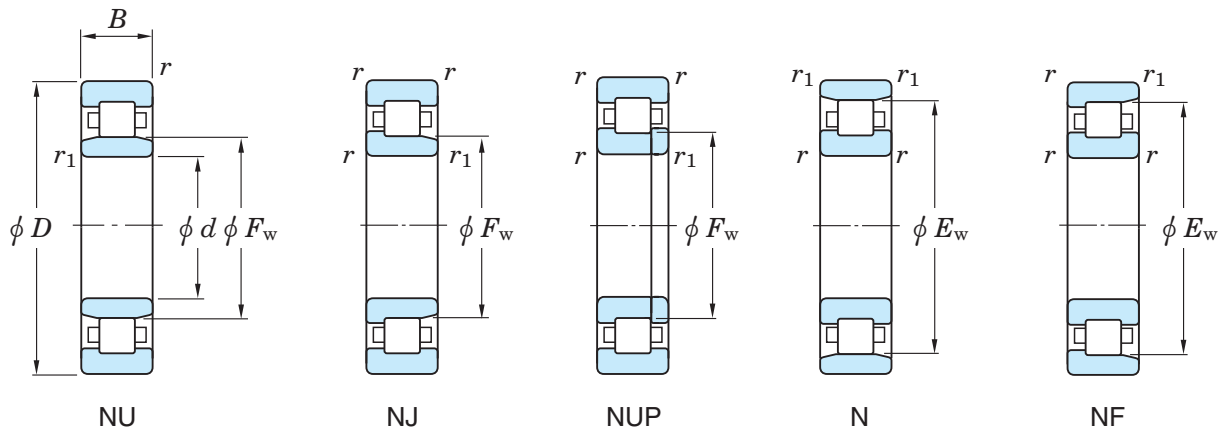

Boundary dimensions (mm)							Basic load ratings (kN)		Limiting speeds (min ⁻¹)		Bearing No.	
d	D	B	$r_{\min.}$	$r_{1\min.}$	F_w	E_w	C_r	C_{Or}	Grease lub.	Oil lub.	NU	NJ
65	140	33	2.1	2.1	82.5	—	181	191	4 300	5 700	NU313R	NJ313R
	140	48	2.1	2.1	83.5	—	190	212	3 900	5 800	NU2313	NJ2313
	140	48	2.1	2.1	82.5	—	251	287	3 800	5 700	NU2313R	NJ2313R
	140	58.7	2.1	2.1	83.5	—	241	294	3 900	5 800	NU3313	—
	160	37	2.1	2.1	89.3	135.3	198	203	4 000	5 300	NU413	NJ413
70	110	20	1.1	1	80	—	57.9	70.4	6 100	7 200	NU1014	—
	125	24	1.5	1.5	84.5	110.5	83.3	95.2	5 100	6 100	NU214	NJ214
	125	24	1.5	1.5	83.5	—	119	137	5 000	6 000	NU214R	NJ214R
	125	31	1.5	1.5	84.5	—	119	151	4 600	6 100	NU2214	NJ2214
	125	31	1.5	1.5	83.5	—	156	194	4 500	6 000	NU2214R	NJ2214R
	125	39.7	1.5	1.5	84.5	—	147	198	4 100	6 100	NU3214	—
	150	35	2.1	2.1	90	130	162	168	4 000	5 400	NU314	NJ314
	150	35	2.1	2.1	89	—	205	222	4 000	5 300	NU314R	NJ314R
	150	51	2.1	2.1	90	—	224	262	3 600	5 400	NU2314	NJ2314
	150	51	2.1	2.1	89	—	275	323	3 600	5 300	NU2314R	NJ2314R
	150	63.5	2.1	2.1	90	—	283	356	3 600	5 400	NU3314	—
75	115	20	1.1	1	85	—	63.6	78.1	5 700	6 800	NU1015	—
	130	25	1.5	1.5	88.5	116.5	101	118	4 800	5 800	NU215	NJ215
	130	25	1.5	1.5	88.5	—	130	156	4 800	5 700	NU215R	NJ215R
	130	31	1.5	1.5	88.5	—	135	172	4 300	5 800	NU2215	NJ2215
	130	31	1.5	1.5	88.5	—	162	207	4 300	5 700	NU2215R	NJ2215R
	130	41.3	1.5	1.5	88.5	—	167	226	3 900	5 800	NU3215	—
	160	37	2.1	2.1	95.5	139.5	194	205	3 800	5 000	NU315	NJ315
	160	37	2.1	2.1	95	—	240	263	3 700	5 000	NU315R	NJ315R
	160	55	2.1	2.1	95.5	—	275	327	3 400	5 000	NU2315	NJ2315
	160	55	2.1	2.1	95	—	329	395	3 300	5 000	NU2315R	NJ2315R

[Remarks] 1) Standard cage types used for the above bearings are shown in Table 1 earlier in this section. Please note that basic load ratings and limiting speeds shown above indicate the value applicable to machined cage. Consult JTEKT about bearings with pressed cage, since they may be different from bearings with machined cage in values above.

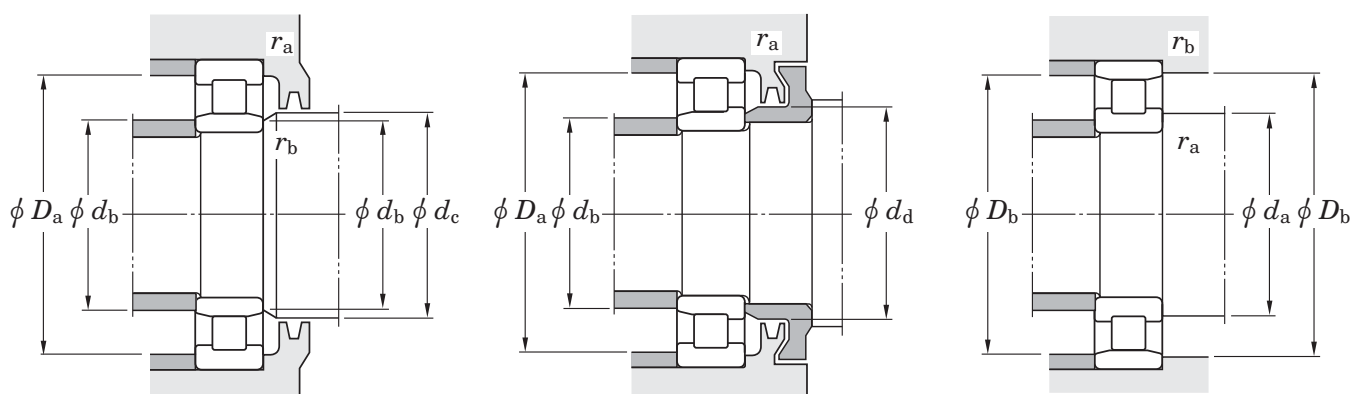

NUP	N	NF	Mounting dimensions (mm)										(Refer.) Mass NU (kg)
			d_a min.	d_b min. max.	d_c min.	d_d min.	D_a max.	D_b max. min.	r_a max.	r_b max.			
NUP313R	—	—	76	76 81	85	93	129	—	—	2	2	2.31	
NUP2313	—	—	76	76 81	85	93	129	—	—	2	2	3.25	
NUP2313R	—	—	76	76 81	85	93	129	—	—	2	2	3.36	
—	—	—	76	76 81	85	—	129	—	—	2	2	4.53	
NUP413	N413	NF413	76	76 88	91	100	149	149	137	2	2	3.58	
NUP1014	—	—	76.5	75 78	82	—	103.5	—	—	1	1	0.702	
NUP214	N214	NF214	78	78 82	86	92	117	117	114	1.5	1.5	1.15	
NUP214R	—	—	78	78 82	86	92	117	—	—	1.5	1.5	1.16	
NUP2214	—	—	78	78 82	86	92	117	—	—	1.5	1.5	1.52	
NUP2214R	—	—	78	78 82	86	92	117	—	—	1.5	1.5	1.53	
—	—	—	78	78 82	86	—	117	—	—	1.5	1.5	2.09	
NUP314	N314	NF314	81	81 87	92	100	139	139	134	2	2	2.73	
NUP314R	—	—	81	81 87	92	100	139	—	—	2	2	2.81	
NUP2314	—	—	81	81 87	92	100	139	—	—	2	2	3.97	
NUP2314R	—	—	81	81 87	92	100	139	—	—	2	2	4.08	
—	—	—	81	81 87	92	—	139	—	—	2	2	5.62	
NUP414	N414	NF414	83	83 99	102	112	167	167	153	2.5	2.5	5.26	
NUP1015	—	—	81.5	80 83	87	—	108.5	—	—	1	1	0.735	
NUP215	N215	NF215	83	83 87	90	96	122	122	120	1.5	1.5	1.24	
NUP215R	—	—	83	83 87	90	96	122	—	—	1.5	1.5	1.29	
NUP2215	—	—	83	83 87	90	96	122	—	—	1.5	1.5	1.57	
NUP2215R	—	—	83	83 87	90	96	122	—	—	1.5	1.5	1.61	
—	—	—	83	83 87	90	—	122	—	—	1.5	1.5	2.28	
NUP315	N315	NF315	86	86 93	97	106	149	149	143	2	2	3.24	
NUP315R	—	—	86	86 93	97	106	149	—	—	2	2	3.37	
NUP2315	—	—	86	86 93	97	106	149	—	—	2	2	4.84	
NUP2315R	—	—	86	86 93	97	106	149	—	—	2	2	5.00	

2) Bearing numbers of NU and NJ type bearings with mounted thrust collar (refer to specification table shown after this specification table) are NUJ and NH.

Single-row cylindrical roller bearings

d (75) ~ (90) mm

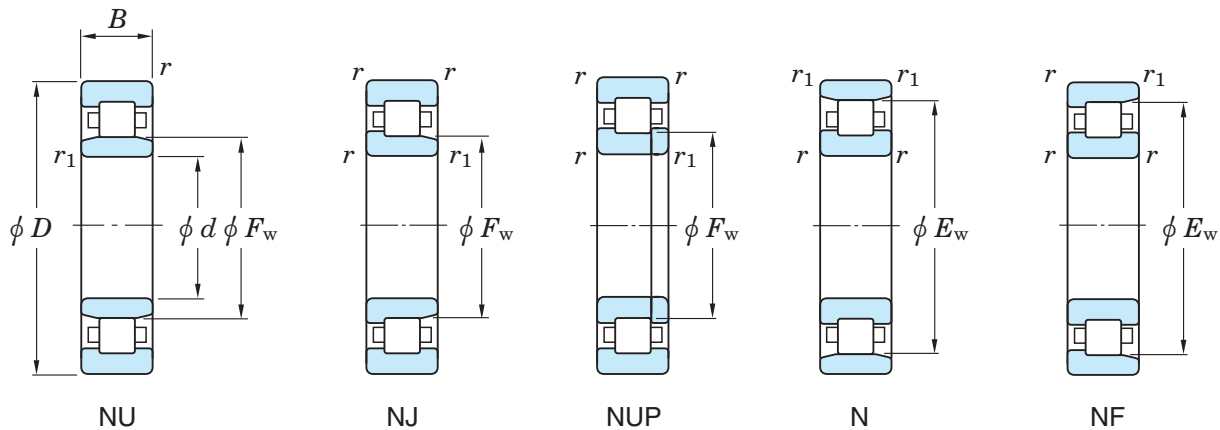

Boundary dimensions (mm)							Basic load ratings (kN)		Limiting speeds (min ⁻¹)		Bearing No.	
d	D	B	$r_{\min.}$	$r_{1\min.}$	F_w	E_w	C_r	C_{Or}	Grease lub.	Oil lub.	NU	NJ
75	160	68.3	2.1	2.1	95.5	—	338	430	3 400	5 000	NU3315	—
	190	45	3	3	104.5	160.5	265	274	3 300	4 400	NU415	NJ415
80	125	22	1.1	1	91.5	—	69.3	86.4	5 300	6 300	NU1016	—
	140	26	2	2	95.3	125.3	106	122	4 500	5 400	NU216	NJ216
	140	26	2	2	95.3	—	139	167	4 400	5 300	NU216R	NJ216R
	140	33	2	2	95.3	—	148	186	4 000	5 400	NU2216	NJ2216
	140	33	2	2	95.3	—	186	243	4 000	5 300	NU2216R	NJ2216R
	140	44.4	2	2	95.3	—	190	259	3 600	5 400	NU3216	—
	170	39	2.1	2.1	103	147	194	207	3 500	4 700	NU316	NJ316
	170	39	2.1	2.1	101	—	259	282	3 500	4 700	NU316R	NJ316R
	170	58	2.1	2.1	103	—	275	332	3 100	4 700	NU2316	NJ2316
	170	58	2.1	2.1	101	—	361	431	3 100	4 700	NU2316R	NJ2316R
	170	68.3	2.1	2.1	103	—	338	436	3 100	4 700	NU3316	—
	200	48	3	3	110	170	302	315	3 100	4 200	NU416	NJ416
85	130	22	1.1	1	96.5	—	71.4	91.2	5 100	6 000	NU1017	—
	150	28	2	2	101.8	133.8	121	140	4 200	5 000	NU217	NJ217
	150	28	2	2	100.5	—	167	199	4 200	5 000	NU217R	NJ217R
	150	36	2	2	101.8	—	169	218	3 800	5 000	NU2217	NJ2217
	150	36	2	2	100.5	—	218	279	3 700	5 000	NU2217R	NJ2217R
	150	49.2	2	2	101.8	—	215	296	3 300	5 000	NU3217	—
	180	41	3	3	108	156	225	247	3 300	4 500	NU317	NJ317
	180	41	3	3	108	—	291	330	3 300	4 400	NU317R	NJ317R
	180	60	3	3	108	—	315	382	3 000	4 500	NU2317	NJ2317
	180	60	3	3	108	—	394	485	2 900	4 400	NU2317R	NJ2317R
	180	73	3	3	108	—	399	517	3 000	4 500	NU3317	—
	210	52	4	4	113	177	340	350	3 000	4 000	NU417	NJ417
90	140	24	1.5	1.1	103	—	84.7	109	4 700	5 600	NU1018	—

[Remarks] 1) Standard cage types used for the above bearings are shown in Table 1 earlier in this section. Please note that basic load ratings and limiting speeds shown above indicate the value applicable to machined cage. Consult JTEKT about bearings with pressed cage, since they may be different from bearings with machined cage in values above.

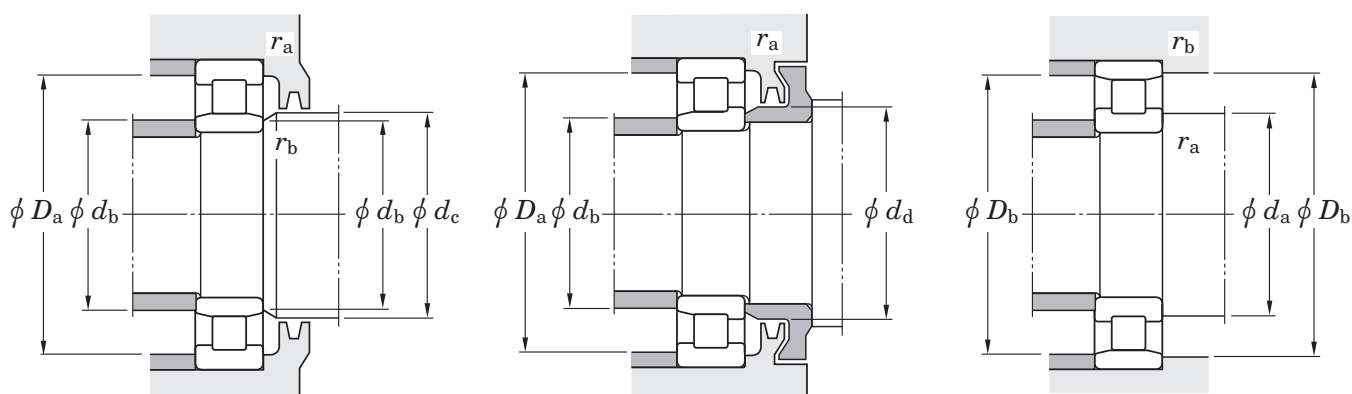

NUP	N	NF	Mounting dimensions (mm)										(Refer.)
			d_a min.	d_b min. max.	d_c min.	d_d min.	D_a max.	D_b max. min.	r_a max.	r_b max.	Mass NU (kg)		
—	—	—	86	86 93	97	—	149	—	—	2	2	6.86	
NUP415	N415	NF415	88	88 103	107	118	177	177	162	2.5	2.5	6.25	
NUP1016	—	—	86.5	85 90	94	—	118.5	—	—	1	1	0.994	
NUP216	N216	NF216	89	89 94	97	104	131	131	128	2	2	1.51	
NUP216R	—	—	89	89 94	97	104	131	—	—	2	2	1.56	
NUP2216	—	—	89	89 94	97	104	131	—	—	2	2	1.96	
NUP2216R	—	—	89	89 94	97	104	131	—	—	2	2	2.03	
—	—	—	89	89 94	97	—	131	—	—	2	2	2.87	
NUP316	N316	NF316	91	91 99	105	114	159	159	151	2	2	3.92	
NUP316R	—	—	91	91 99	105	114	159	—	—	2	2	4.00	
NUP2316	—	—	91	91 99	105	114	159	—	—	2	2	5.83	
NUP2316R	—	—	91	91 99	105	114	159	—	—	2	2	5.95	
—	—	—	91	91 99	105	—	159	—	—	2	2	7.72	
NUP416	N416	NF416	93	93 109	112	124	187	187	172	2.5	2.5	7.28	
NUP1017	—	—	91.5	90 95	99	—	123.5	—	—	1	1	1.04	
NUP217	N217	NF217	94	94 99	104	110	141	141	137	2	2	1.90	
NUP217R	—	—	94	94 99	104	110	141	—	—	2	2	1.94	
NUP2217	—	—	94	94 99	104	110	141	—	—	2	2	2.50	
NUP2217R	—	—	94	94 99	104	110	141	—	—	2	2	2.53	
—	—	—	94	94 99	104	—	141	—	—	2	2	3.67	
NUP317	N317	NF317	98	98 106	110	119	167	167	160	2.5	2.5	4.52	
NUP317R	—	—	98	98 106	110	119	167	—	—	2.5	2.5	4.80	
NUP2317	—	—	98	98 106	110	119	167	—	—	2.5	2.5	6.62	
NUP2317R	—	—	98	98 106	110	119	167	—	—	2.5	2.5	6.98	
—	—	—	98	98 106	110	—	167	—	—	2.5	2.5	9.23	
NUP417	N417	NF417	101	101 111	115	128	194	194	179	3	3	8.68	
NUP1018	—	—	98	96.5 101	106	—	132	—	—	1.5	1	1.34	

2) Bearing numbers of NU and NJ type bearings with mounted thrust collar (refer to specification table shown after this specification table) are NUJ and NH.

Single-row cylindrical roller bearings

d (90) ~ (100) mm

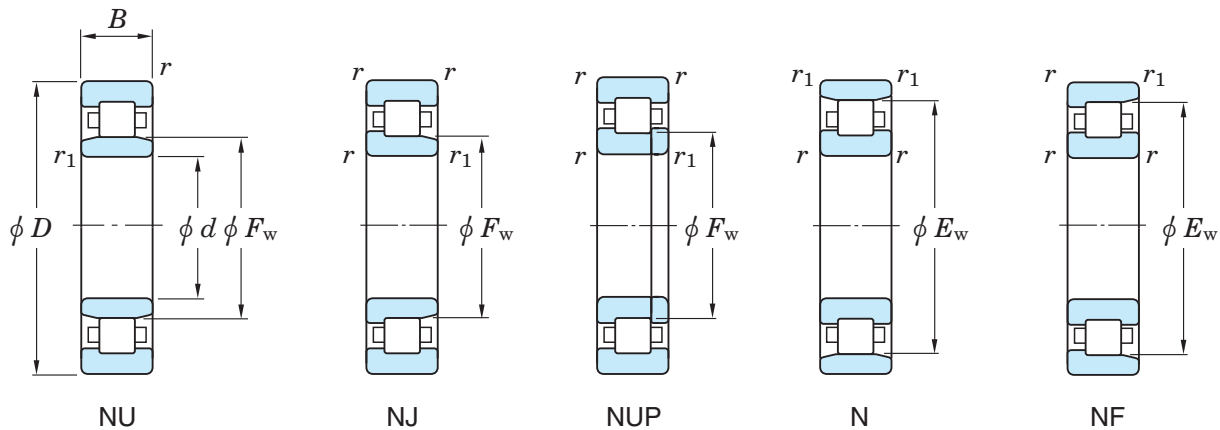

Boundary dimensions (mm)							Basic load ratings (kN)		Limiting speeds (min ⁻¹)		Bearing No.	
d	D	B	r min.	r_1 min.	F_w	E_w	C_r	C_{Or}	Grease lub.	Oil lub.	NU	NJ
90	160	30	2	2	107	143	152	178	3 900	4 700	NU218	NJ218
	160	30	2	2	107	—	182	217	3 900	4 700	NU218R	NJ218R
	160	40	2	2	107	—	207	265	3 500	4 700	NU2218	NJ2218
	160	40	2	2	107	—	242	314	3 500	4 700	NU2218R	NJ2218R
	160	52.4	2	2	107	—	270	373	3 100	4 700	NU3218	—
	190	43	3	3	115	165	243	265	3 100	4 200	NU318	NJ318
	190	43	3	3	113.5	—	316	355	3 100	4 100	NU318R	NJ318R
	190	64	3	3	115	—	329	395	2 800	4 200	NU2318	NJ2318
	190	64	3	3	113.5	—	437	534	2 800	4 100	NU2318R	NJ2318R
	190	73	3	3	115	—	428	559	2 800	4 200	NU3318	—
	225	54	4	4	123.5	191.5	374	400	2 800	3 700	NU418	NJ418
95	145	24	1.5	1.1	108	—	87.2	115	4 500	5 300	NU1019	—
	170	32	2.1	2.1	113.5	151.5	165	195	3 700	4 400	NU219	NJ219
	170	32	2.1	2.1	112.5	—	221	265	3 700	4 400	NU219R	NJ219R
	170	43	2.1	2.1	113.5	—	230	298	3 300	4 400	NU2219	NJ2219
	170	43	2.1	2.1	112.5	—	287	371	3 300	4 400	NU2219R	NJ2219R
	170	55.6	2.1	2.1	113.5	—	297	412	3 000	4 400	NU3219	—
	200	45	3	3	121.5	173.5	277	311	3 000	4 000	NU319	NJ319
	200	45	3	3	121.5	—	334	387	2 900	3 900	NU319R	NJ319R
	200	67	3	3	121.5	—	394	496	2 600	4 000	NU2319	NJ2319
	200	77.8	3	3	121.5	—	487	654	2 600	4 000	NU3319	—
	240	55	4	4	133.5	201.5	410	444	2 600	3 400	NU419	NJ419
100	150	24	1.5	1.1	113	—	91.0	120	4 300	5 100	NU1020	—
	180	34	2.1	2.1	120	160	183	217	3 500	4 200	NU220	NJ220
	180	34	2.1	2.1	119	—	250	306	3 500	4 200	NU220R	NJ220R
	180	46	2.1	2.1	120	—	259	338	3 100	4 200	NU2220	NJ2220
	180	46	2.1	2.1	119	—	334	444	3 100	4 200	NU2220R	NJ2220R

[Remarks] 1) Standard cage types used for the above bearings are shown in Table 1 earlier in this section. Please note that basic load ratings and limiting speeds shown above indicate the value applicable to machined cage. Consult JTEKT about bearings with pressed cage, since they may be different from bearings with machined cage in values above.

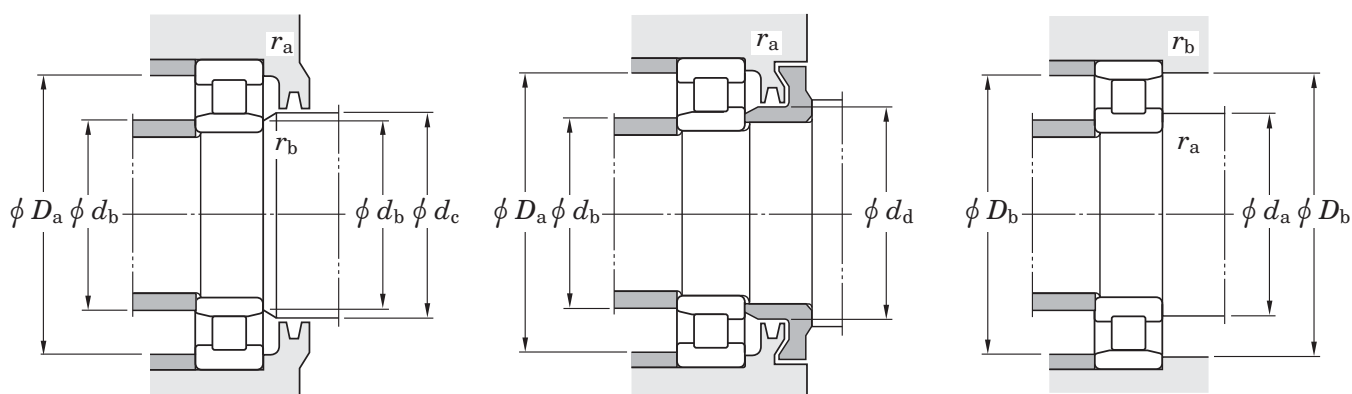

NUP	N	NF	Mounting dimensions (mm)										(Refer.) Mass NU (kg)
			d_a min.	d_b min. max.	d_c min.	d_d min.	D_a max.	D_b max. min.	r_a max.	r_b max.			
NUP218	N218	NF218	99	99 105	109	116	151	151	146	2	2	2.28	
NUP218R	—	—	99	99 105	109	116	151	—	—	2	2	2.38	
NUP2218	—	—	99	99 105	109	116	151	—	—	2	2	3.10	
NUP2218R	—	—	99	99 105	109	116	151	—	—	2	2	3.21	
—	—	—	99	99 105	109	—	151	—	—	2	2	4.49	
NUP318	N318	NF318	103	103 111	117	127	177	177	169	2.5	2.5	5.38	
NUP318R	—	—	103	103 111	117	127	177	—	—	2.5	2.5	5.47	
NUP2318	—	—	103	103 111	117	127	177	—	—	2.5	2.5	7.90	
NUP2318R	—	—	103	103 111	117	127	177	—	—	2.5	2.5	8.12	
—	—	—	103	103 111	117	—	177	—	—	2.5	2.5	10.3	
NUP418	N418	NF418	106	106 122	125	139	209	209	194	3	3	10.3	
NUP1019	—	—	103	101.5 106	111	—	137	—	—	1.5	1	1.40	
NUP219	N219	NF219	106	106 111	116	123	159	159	155	2	2	2.80	
NUP219R	—	—	106	106 111	116	123	159	—	—	2	2	2.92	
NUP2219	—	—	106	106 111	116	123	159	—	—	2	2	3.85	
NUP2219R	—	—	106	106 111	116	123	159	—	—	2	2	3.93	
—	—	—	106	106 111	116	—	159	—	—	2	2	5.42	
NUP319	N319	NF319	108	108 119	124	134	187	187	178	2.5	2.5	6.20	
NUP319R	—	—	108	108 119	124	134	187	—	—	2.5	2.5	6.42	
NUP2319	—	—	108	108 119	124	134	187	—	—	2.5	2.5	9.39	
—	—	—	108	108 119	124	—	187	—	—	2.5	2.5	12.1	
NUP419	N419	NF419	111	111 132	136	149	224	224	204	3	3	13.6	
NUP1020	—	—	108	106.5 111	116	—	142	—	—	1.5	1	1.46	
NUP220	N220	NF220	111	111 117	122	130	169	169	164	2	2	3.38	
NUP220R	—	—	111	111 117	122	130	169	—	—	2	2	3.52	
NUP2220	—	—	111	111 117	122	130	169	—	—	2	2	4.67	
NUP2220R	—	—	111	111 117	122	130	169	—	—	2	2	4.82	

2) Bearing numbers of NU and NJ type bearings with mounted thrust collar (refer to specification table shown after this specification table) are NUJ and NH.

Single-row cylindrical roller bearings

d (100) ~ 110 mm

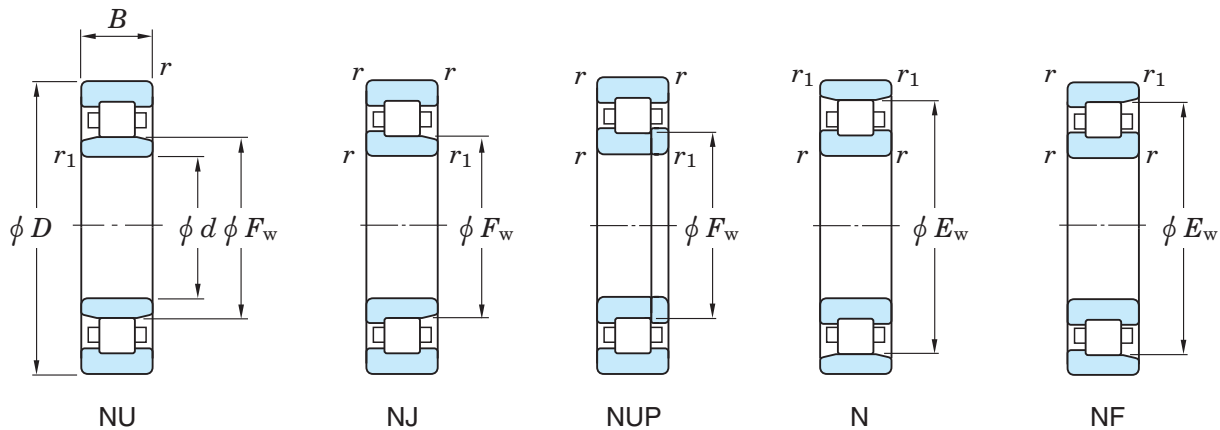

d	Boundary dimensions (mm)						Basic load ratings (kN)		Limiting speeds (min ⁻¹)		Bearing No.	
	D	B	$r_{\min.}$	$r_{1\min.}$	F_w	E_w	C_r	C_{Or}	Grease lub.	Oil lub.	NU	NJ
100	180	60.3	2.1	2.1	120	—	327	459	2 800	4 200	NU3220	—
	215	47	3	3	129.5	185.5	323	337	2 800	3 700	NU320	NJ320
	215	47	3	3	127.5	—	379	424	2 700	3 600	NU320R	NJ320R
	215	73	3	3	129.5	—	464	548	2 500	3 700	NU2320	NJ2320
	215	73	3	3	127.5	—	570	717	2 400	3 600	NU2320R	NJ2320R
	215	82.6	3	3	129.5	—	530	706	2 500	3 700	NU3320	—
	250	58	4	4	139	211	458	498	2 500	3 300	NU420	NJ420
105	160	26	2	1.1	119.5	—	108	149	4 100	4 800	NU1021	—
	190	36	2.1	2.1	126.8	168.8	201	241	3 300	3 900	NU221	NJ221
	190	65.1	2.1	2.1	126.8	—	344	482	2 600	3 900	NU3221	—
	225	49	3	3	135	195	366	417	2 600	3 500	NU321	NJ321
	225	77	3	3	135	—	568	750	2 300	3 500	NU2321	—
	225	87.3	3	3	135	—	638	871	2 300	3 500	NU3321	—
	260	60	4	4	144.5	220.5	471	510	2 400	3 100	NU421	NJ421
110	170	28	2	1.1	125	—	134	171	3 800	4 500	NU1022	—
	200	38	2.1	2.1	132.5	178.5	241	290	3 100	3 700	NU222	NJ222
	200	38	2.1	2.1	132.5	—	293	365	3 100	3 700	NU222R	NJ222R
	200	53	2.1	2.1	132.5	—	334	442	2 800	3 700	NU2222	NJ2222
	200	53	2.1	2.1	132.5	—	384	517	2 800	3 700	NU2222R	NJ2222R
	200	69.8	2.1	2.1	132.5	—	427	607	2 500	3 700	NU3222	—
	240	50	3	3	143	207	411	467	2 500	3 300	NU322	NJ322
	240	50	3	3	143	—	451	525	2 400	3 200	NU322R	NJ322R
	240	80	3	3	143	—	604	789	2 200	3 300	NU2322	NJ2322
	240	80	3	3	143	—	680	880	2 200	3 200	NU2322R	NJ2322R
	240	92.1	3	3	143	—	678	918	2 200	3 300	NU3322	—
	280	65	4	4	155	235	550	621	2 200	2 900	NU422	NJ422

[Remarks] 1) Standard cage types used for the above bearings are shown in Table 1 earlier in this section. Please note that basic load ratings and limiting speeds shown above indicate the value applicable to machined cage. Consult JTEKT about bearings with pressed cage, since they may be different from bearings with machined cage in values above.

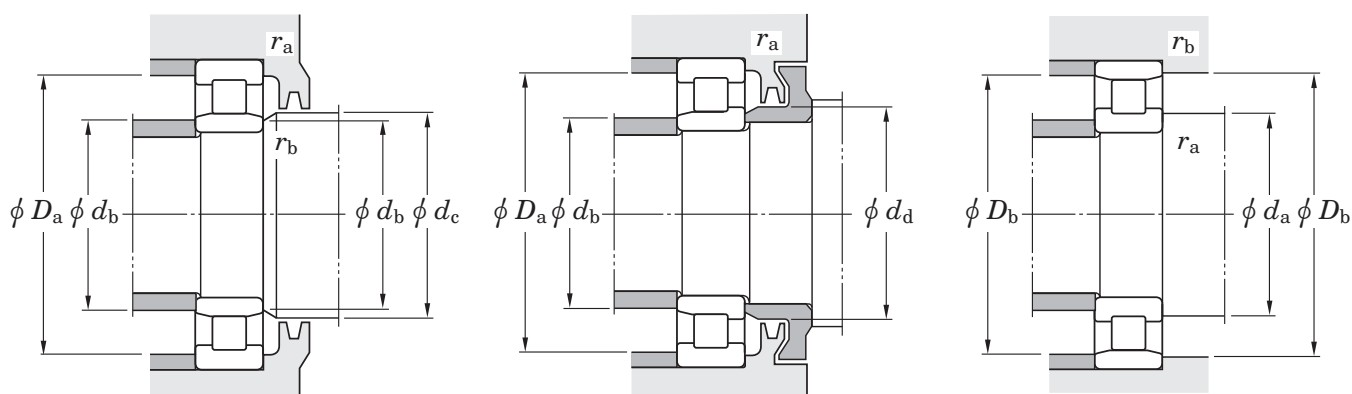

NUP	N	NF	Mounting dimensions (mm)										(Refer.) Mass NU (kg)
			d_a min.	d_b min.	d_b max.	d_c min.	d_d min.	D_a max.	D_b max.	d_b min.	r_a max.	r_b max.	
—	—	—	111	111	117	122	—	169	—	—	2	2	6.62
NUP320	N320	NF320	113	113	125	132	143	202	202	190	2.5	2.5	7.70
NUP320R	—	—	113	113	125	132	143	202	—	—	2.5	2.5	7.75
NUP2320	—	—	113	113	125	132	143	202	—	—	2.5	2.5	11.9
NUP2320R	—	—	113	113	125	132	143	202	—	—	2.5	2.5	12.1
—	—	—	113	113	125	132	—	202	—	—	2.5	2.5	15.0
NUP420	N420	NF420	116	116	137	141	156	234	234	213	3	3	14.0
NUP1021	—	—	114	111.5	118	122	—	151	—	—	2	1	1.85
NUP221	N221	NF221	116	116	124	129	137	179	179	173	2	2	4.00
—	—	—	116	116	124	129	—	179	—	—	2	2	8.00
NUP321	N321	NF321	118	118	132	137	149	212	212	199	2.5	2.5	8.76
NUP2321	—	—	118	118	131	138	—	212	—	—	2.5	2.5	15.6
—	—	—	118	118	132	137	—	212	—	—	2.5	2.5	17.4
NUP421	N421	NF421	121	121	143	147	162	244	244	223	3	3	19.1
NUP1022	—	—	119	116.5	124	128	—	161	—	—	2	1	2.31
NUP222	N222	NF222	121	121	130	135	144	189	189	182	2	2	4.65
NUP222R	—	—	121	121	130	135	144	189	—	—	2	2	4.90
NUP2222	—	—	121	121	130	135	144	189	—	—	2	2	6.93
NUP2222R	—	—	121	121	130	135	144	189	—	—	2	2	6.93
—	—	—	121	121	130	135	—	189	—	—	2	2	9.55
NUP322	N322	NF322	123	123	140	145	158	227	227	211	2.5	2.5	10.4
NUP322R	—	—	123	123	140	145	158	227	—	—	2.5	2.5	10.7
NUP2322	—	—	123	123	140	145	158	227	—	—	2.5	2.5	18.8
NUP2322R	—	—	123	123	140	145	158	227	—	—	2.5	2.5	18.8
—	—	—	123	123	140	145	—	227	—	—	2.5	2.5	21.1
NUP422	N422	NF422	126	126	153	157	173	264	264	237	3	3	19.9

2) Bearing numbers of NU and NJ type bearings with mounted thrust collar (refer to specification table shown after this specification table) are NUJ and NH.

Single-row cylindrical roller bearings

d 120 ~ (140) mm

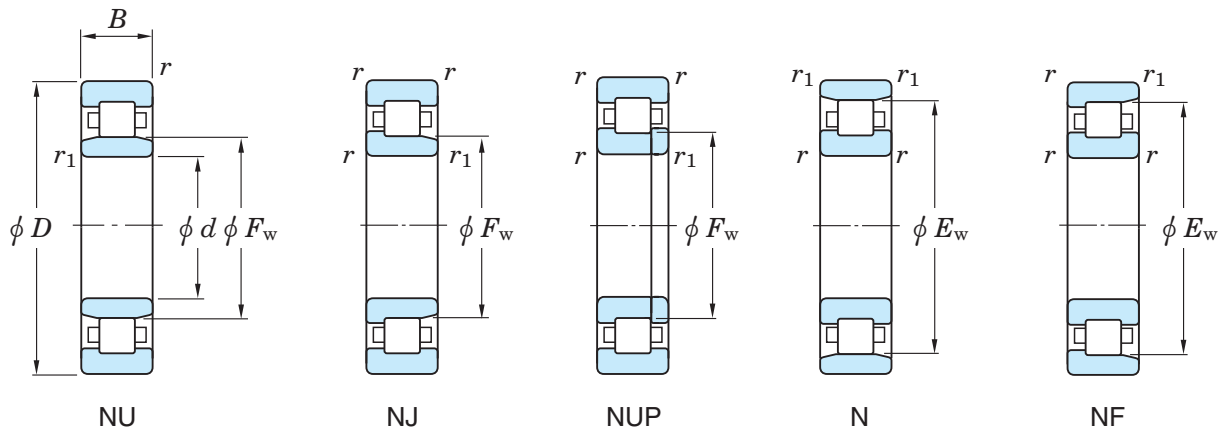

Boundary dimensions (mm)							Basic load ratings (kN)		Limiting speeds (min ⁻¹)		Bearing No.	
d	D	B	$r_{\min.}$	$r_{1\min.}$	F_w	E_w	C_r	C_{Or}	Grease lub.	Oil lub.	NU	NJ
120	180	28	2	1.1	135	—	137	181	3 500	4 200	NU1024	—
	215	40	2.1	2.1	143.5	191.5	260	318	2 900	3 400	NU224	NJ224
	215	40	2.1	2.1	143.5	—	336	421	2 800	3 400	NU224R	NJ224R
	215	58	2.1	2.1	143.5	—	367	492	2 600	3 400	NU2224	NJ2224
	215	58	2.1	2.1	143.5	—	452	619	2 600	3 400	NU2224R	NJ2224R
	215	76	2.1	2.1	143.5	—	477	695	2 300	3 400	NU3224	—
	260	55	3	3	154	226	485	551	2 200	3 000	NU324	NJ324
	260	55	3	3	154	—	528	610	2 200	3 000	NU324R	NJ324R
	260	86	3	3	154	—	708	918	2 000	3 000	NU2324	NJ2324
	260	86	3	3	154	—	793	1 030	2 000	3 000	NU2324R	NJ2324R
	260	106	3	3	154	—	826	1 120	2 000	3 000	NU3324	—
310	72	5	5	170	260	690	770	1 900	2 600	NU424	NJ424	
130	200	33	2	1.1	148	—	171	238	3 200	3 800	NU1026	—
	230	40	3	3	156	204	282	362	2 700	3 200	NU226	NJ226
	230	40	3	3	153.5	—	364	453	2 600	3 200	NU226R	NJ226R
	230	64	3	3	156	—	395	560	2 400	3 200	NU2226	NJ2226
	230	64	3	3	153.5	—	530	737	2 400	3 200	NU2226R	NJ2226R
	230	80	3	3	156	—	550	857	2 100	3 200	NU3226	—
	280	58	4	4	167	243	564	667	2 100	2 700	NU326	NJ326
	280	58	4	4	167	—	616	736	2 000	2 700	NU326R	NJ326R
	280	93	4	4	167	—	838	1 130	1 800	2 700	NU2326	NJ2326
	280	93	4	4	167	—	920	1 230	1 800	2 700	NU2326R	NJ2326R
	280	112	4	4	167	—	936	1 290	1 800	2 700	NU3326	—
340	78	5	5	185	285	771	876	1 800	2 300	NU426	NJ426	
140	210	33	2	1.1	158	—	175	250	3 000	3 600	NU1028	—
	250	42	3	3	169	221	324	421	2 400	2 900	NU228	NJ228
	250	42	3	3	169	—	392	514	2 400	2 900	NU228R	NJ228R

[Remarks] 1) Standard cage types used for the above bearings are shown in Table 1 earlier in this section. Please note that basic load ratings and limiting speeds shown above indicate the value applicable to machined cage. Consult JTEKT about bearings with pressed cage, since they may be different from bearings with machined cage in values above.

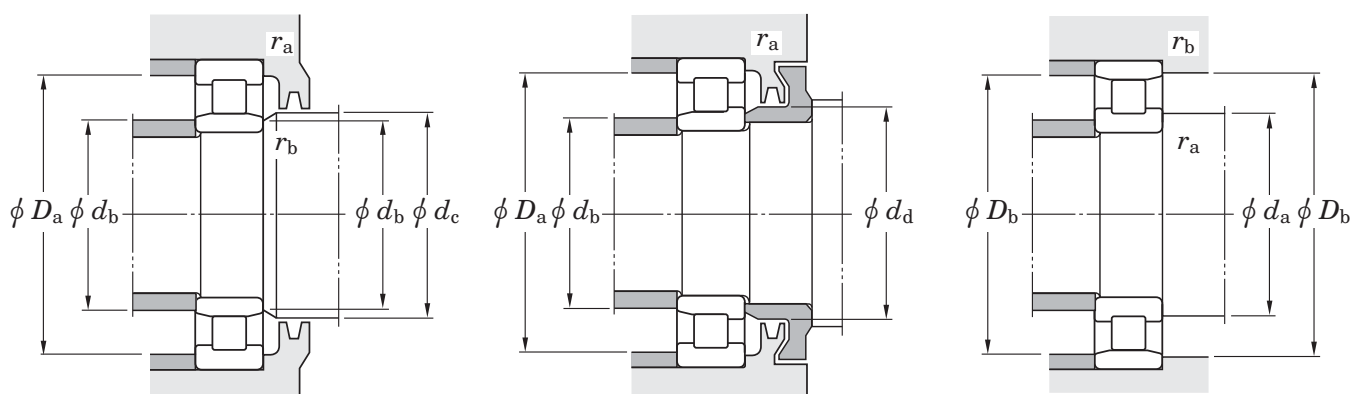

NUP	N	NF	Mounting dimensions (mm)										(Refer.) Mass NU (kg)
			d_a min.	d_b min. max.	d_c min.	d_d min.	D_a max.	D_b max. min.	r_a max.	r_b max.			
NUP1024	—	—	129	126.5 134	138	—	171	—	—	2	1	2.47	
NUP224	N224	NF224	131	131 141	146	156	204	204	196	2	2	5.65	
NUP224R	—	—	131	131 141	146	156	204	—	—	2	2	5.85	
NUP2224	—	—	131	131 141	146	156	204	—	—	2	2	8.56	
NUP2224R	—	—	131	131 141	146	156	204	—	—	2	2	8.56	
—	—	—	131	131 141	146	—	204	—	—	2	2	11.9	
NUP324	N324	NF324	133	133 151	156	171	247	247	230	2.5	2.5	13.1	
NUP324R	—	—	133	133 151	156	171	247	—	—	2.5	2.5	13.4	
NUP2324	—	—	133	133 151	156	171	247	—	—	2.5	2.5	23.1	
NUP2324R	—	—	133	133 151	156	172	247	—	—	2.5	2.5	23.1	
—	—	—	133	133 151	156	—	247	—	—	2.5	2.5	28.3	
NUP424	N424	NF424	140	140 168	172	190	290	290	262	4	4	28.0	
NUP1026	—	—	139	136.5 146	151	—	191	—	—	2	1	3.77	
NUP226	N226	NF226	143	143 151	158	168	217	217	208	2.5	2.5	6.49	
NUP226R	—	—	143	143 151	158	168	217	—	—	2.5	2.5	6.60	
NUP2226	—	—	143	143 151	158	168	217	—	—	2.5	2.5	11.2	
NUP2226R	—	—	143	143 151	158	168	217	—	—	2.5	2.5	11.2	
—	—	—	143	143 151	158	—	217	—	—	2.5	2.5	14.1	
NUP326	N326	NF326	146	146 164	169	184	264	264	247	3	3	16.4	
NUP326R	—	—	146	146 164	169	184	264	—	—	3	3	16.7	
NUP2326	—	—	146	146 164	169	184	264	—	—	3	3	29.1	
NUP2326R	—	—	146	146 164	169	186	264	—	—	3	3	29.1	
—	—	—	146	146 164	169	—	264	—	—	3	3	34.6	
NUP426	N426	NF426	150	150 183	187	208	320	320	287	4	4	36.1	
NUP1028	—	—	149	146.5 156	161	—	201	—	—	2	1	4.00	
NUP228	N228	NF228	153	153 166	171	182	237	237	228	2.5	2.5	8.27	
NUP228R	—	—	153	153 166	171	182	237	—	—	2.5	2.5	8.50	

2) Bearing numbers of NU and NJ type bearings with mounted thrust collar (refer to specification table shown after this specification table) are NUJ and NH.

Single-row cylindrical roller bearings

d (140) ~ (160) mm

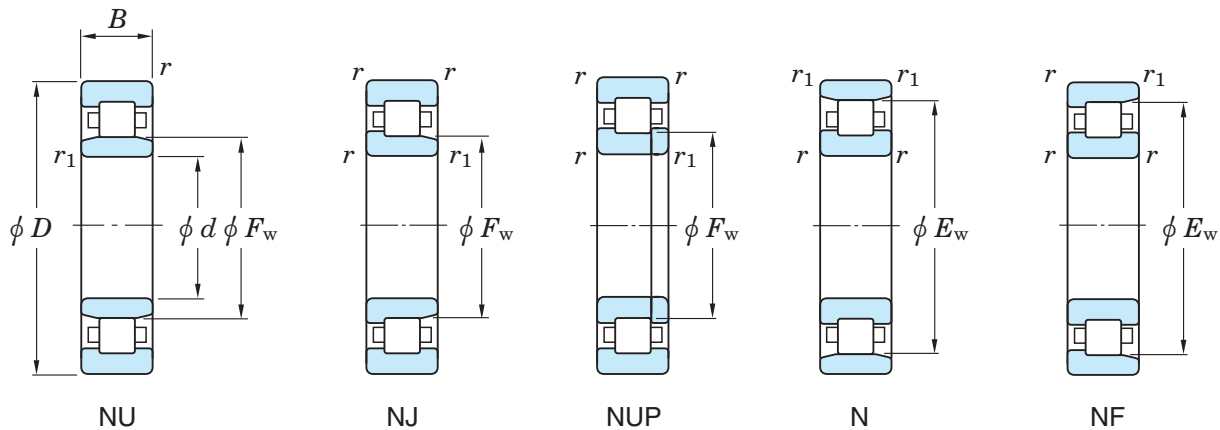

d	Boundary dimensions (mm)						Basic load ratings (kN)		Limiting speeds (min^{-1})		Bearing No.	
	D	B	$r_{\text{min.}}$	$r_{1\text{min.}}$	F_w	E_w	C_r	C_{Or}	Grease lub.	Oil lub.	NU	NJ
140	250	68	3	3	169	—	465	671	2 200	2 900	NU2228	NJ2228
	250	68	3	3	169	—	572	835	2 200	2 900	NU2228R	NJ2228R
	250	88	3	3	169	—	604	939	1 900	2 900	NU3228	—
	300	62	4	4	180	260	623	746	1 900	2 500	NU328	NJ328
	300	62	4	4	180	—	663	797	1 900	2 500	NU328R	NJ328R
	300	102	4	4	180	—	920	1 250	1 700	2 500	NU2328	NJ2328
	300	102	4	4	180	—	1 020	1 380	1 700	2 500	NU2328R	NJ2328R
	300	118	4	4	180	—	1 090	1 550	1 700	2 500	NU3328	—
	360	82	5	5	198	302	874	1 020	1 600	2 200	NU428	NJ428
150	225	35	2.1	1.5	169.5	—	201	281	2 800	3 300	NU1030	—
	270	45	3	3	182	238	374	492	2 200	2 700	NU230	NJ230
	270	45	3	3	182	—	448	594	2 200	2 600	NU230R	NJ230R
	270	73	3	3	182	—	545	800	2 000	2 700	NU2230	NJ2230
	270	73	3	3	182	—	662	982	2 000	2 600	NU2230R	NJ2230R
	270	96	3	3	182	—	749	1 200	1 800	2 700	NU3230	—
	320	65	4	4	193	277	663	807	1 800	2 300	NU330	NJ330
	320	65	4	4	193	—	757	922	1 700	2 300	NU330R	NJ330R
	320	108	4	4	193	—	1 020	1 400	1 600	2 300	NU2330	NJ2330
	320	108	4	4	193	—	1 180	1 600	1 500	2 300	NU2330R	NJ2330R
	320	128	4	4	193	—	1 290	1 890	1 600	2 300	NU3330	—
	380	85	5	5	213	317	930	1 120	1 500	2 000	NU430	NJ430
160	240	38	2.1	1.5	180	—	236	330	2 600	3 000	NU1032	—
	290	48	3	3	195	255	427	568	2 100	2 500	NU232	NJ232
	290	48	3	3	195	—	498	666	2 000	2 400	NU232R	NJ232R
	290	80	3	3	195	—	631	939	1 800	2 500	NU2232	NJ2232
	290	80	3	3	193	—	809	1 190	1 800	2 400	NU2232R	NJ2232R
	290	104	3	3	195	—	857	1 390	1 600	2 500	NU3232	—

[Remarks] 1) Standard cage types used for the above bearings are shown in Table 1 earlier in this section. Please note that basic load ratings and limiting speeds shown above indicate the value applicable to machined cage. Consult JTEKT about bearings with pressed cage, since they may be different from bearings with machined cage in values above.

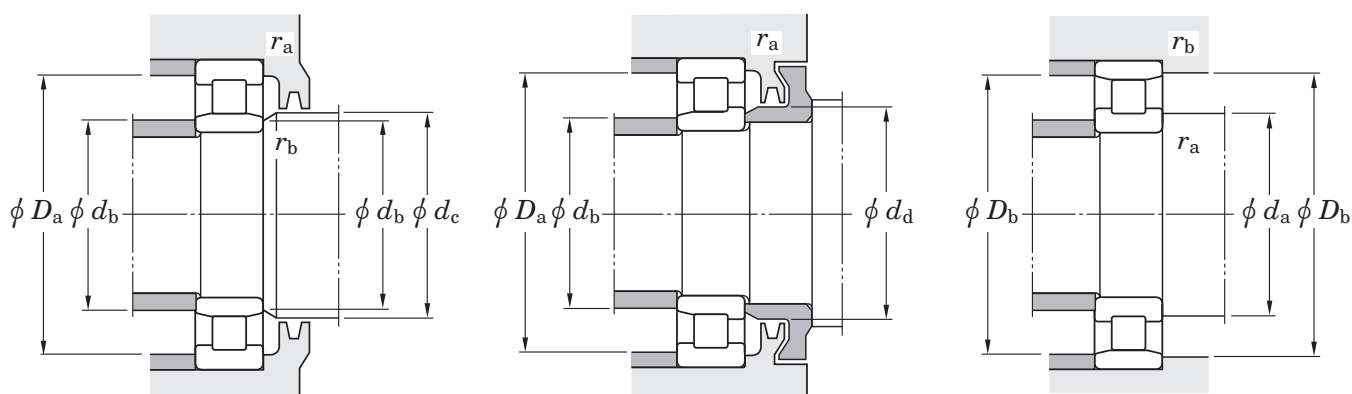

NUP	N	NF	Mounting dimensions (mm)										(Refer.) Mass NU (kg)
			d_a min.	d_b min. max.	d_c min.	d_d min.	D_a max.	D_b max. min.	r_a max.	r_b max.			
NUP2228	—	—	153	153	166	171	182	237	—	—	2.5	2.5	14.3
NUP2228R	—	—	153	153	166	171	182	237	—	—	2.5	2.5	14.3
—	—	—	153	153	166	171	—	237	—	—	2.5	2.5	18.5
NUP328	N328	NF328	156	156	176	182	198	284	284	264	3	3	21.8
NUP328R	—	—	156	156	176	182	198	284	—	—	3	3	21.8
NUP2328	—	—	156	156	176	182	198	284	—	—	3	3	36.8
NUP2328R	—	—	156	156	176	182	200	284	—	—	3	3	36.8
—	—	—	156	156	176	182	—	284	—	—	3	3	41.5
NUP428	N428	NF428	160	160	195	200	222	340	340	304	4	4	46.8
NUP1030	—	—	161	158	167	173	—	214	—	—	2	1.5	4.83
NUP230	N230	NF230	163	163	179	184	196	257	257	245	2.5	2.5	10.3
NUP230R	—	—	163	163	179	184	196	257	—	—	2.5	2.5	10.7
NUP2230	—	—	163	163	179	184	196	257	—	—	2.5	2.5	18.7
NUP2230R	—	—	163	163	179	184	196	257	—	—	2.5	2.5	18.7
—	—	—	163	163	179	184	—	257	—	—	2.5	2.5	23.7
NUP330	N330	NF330	166	166	190	195	213	304	304	281	3	3	26.4
NUP330R	—	—	166	166	190	195	213	304	—	—	3	3	27.0
NUP2330	—	—	166	166	190	195	213	304	—	—	3	3	44.7
NUP2330R	—	—	166	166	190	195	213	304	—	—	3	3	44.7
—	—	—	166	166	190	195	—	304	—	—	3	3	51.4
NUP430	N430	NF430	170	170	210	216	237	360	360	319	4	4	53.3
NUP1032	—	—	171	168	178	184	—	229	—	—	2	1.5	5.93
NUP232	N232	NF232	173	173	192	197	210	277	277	262	2.5	2.5	14.4
NUP232R	—	—	173	173	192	197	210	277	—	—	2.5	2.5	14.8
NUP2232	—	—	173	173	192	197	210	277	—	—	2.5	2.5	23.6
NUP2232R	—	—	173	173	192	197	210	277	—	—	2.5	2.5	23.6
—	—	—	173	173	192	197	—	277	—	—	2.5	2.5	29.8

2) Bearing numbers of NU and NJ type bearings with mounted thrust collar (refer to specification table shown after this specification table) are NUJ and NH.

Single-row cylindrical roller bearings

d (160) ~ (190) mm

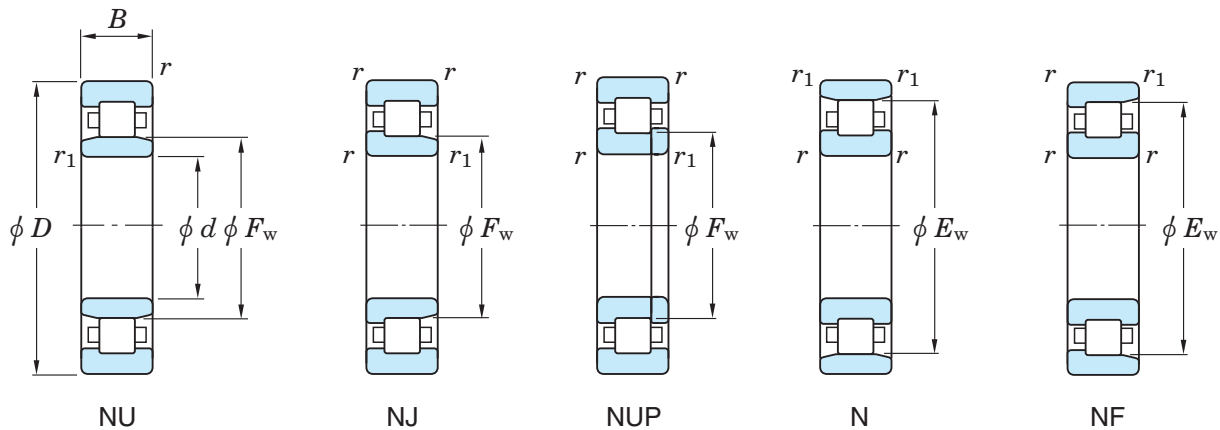

Boundary dimensions (mm)							Basic load ratings (kN)		Limiting speeds (min ⁻¹)		Bearing No.	
d	D	B	$r_{\min.}$	$r_{1\min.}$	F_w	E_w	C_r	C_{Or}	Grease lub.	Oil lub.	NU	NJ
160	340	68	4	4	208	292	698	876	1 600	2 200	NU332	NJ332
	340	68	4	4	204	—	857	1 050	1 600	2 100	NU332R	NJ332R
	340	114	4	4	208	—	1 070	1 520	1 400	2 200	NU2332	NJ2332
	340	114	4	4	204	—	1 310	1 820	1 400	2 100	NU2332R	NJ2332R
	340	136	4	4	208	—	1 270	1 890	1 400	2 200	NU3332	—
170	260	42	2.1	2.1	193	—	276	400	2 400	2 800	NU1034	—
	310	52	4	4	208	272	475	637	1 900	2 300	NU234	NJ234
	310	52	4	4	207	—	603	802	1 900	2 200	NU234R	NJ234R
	310	86	4	4	208	—	715	1 080	1 700	2 300	NU2234	NJ2234
	310	86	4	4	205	—	967	1 410	1 700	2 200	NU2234R	NJ2234R
	310	110	4	4	208	—	964	1 580	1 500	2 300	NU3234	—
	360	72	4	4	220	310	809	1 010	1 500	2 000	NU334	NJ334
	360	120	4	4	220	—	1 220	1 750	1 300	2 000	NU2334	NJ2334
360	140	4	4	220	—	1 420	2 120	1 300	2 000	NU3334	—	
180	280	46	2.1	2.1	205	—	356	503	2 200	2 600	NU1036	—
	320	52	4	4	218	282	492	677	1 800	2 200	NU236	NJ236
	320	52	4	4	217	—	626	852	1 800	2 100	NU236R	NJ236R
	320	86	4	4	218	—	741	1 140	1 600	2 200	NU2236	NJ2236
	320	86	4	4	215	—	1 010	1 510	1 600	2 100	NU2236R	NJ2236R
	320	112	4	4	218	—	999	1 680	1 400	2 200	NU3236	—
	380	75	4	4	232	328	917	1 150	1 400	1 900	NU336	NJ336
	380	126	4	4	232	—	1 350	1 940	1 300	1 900	NU2336	NJ2336
380	150	4	4	232	—	1 660	2 520	1 300	1 900	NU3336	—	
190	290	46	2.1	2.1	215	—	366	530	2 100	2 500	NU1038	—
	340	55	4	4	231	299	554	768	1 700	2 000	NU238	NJ238
	340	55	4	4	230	—	694	954	1 700	2 000	NU238R	NJ238R
	340	92	4	4	231	—	828	1 290	1 500	2 000	NU2238	NJ2238

[Remarks] 1) Standard cage types used for the above bearings are shown in Table 1 earlier in this section. Please note that basic load ratings and limiting speeds shown above indicate the value applicable to machined cage. Consult JTEKT about bearings with pressed cage, since they may be different from bearings with machined cage in values above.

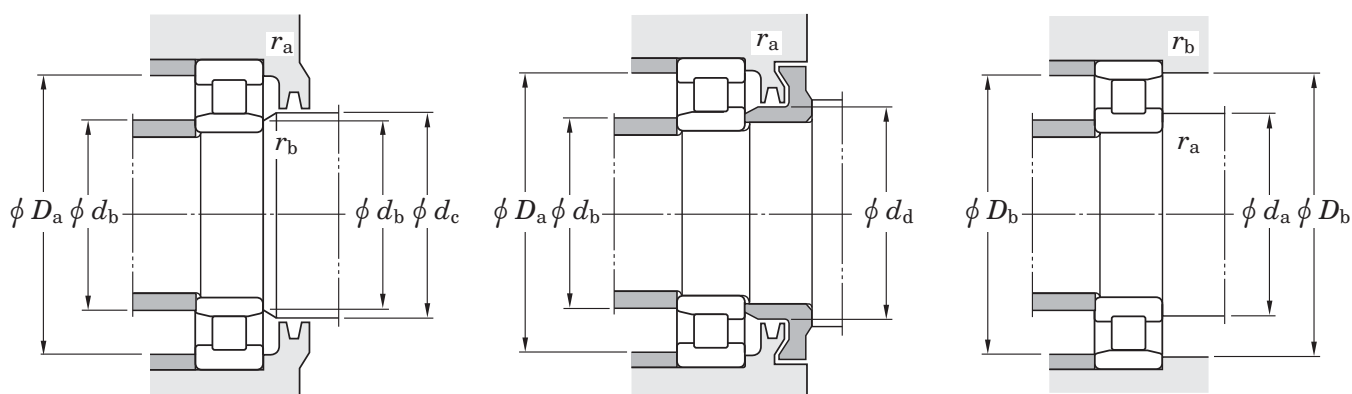

NUP	N	NF	Mounting dimensions (mm)										(Refer.) Mass NU (kg)
			d_a min.	d_b min.	d_b max.	d_c min.	d_d min.	D_a max.	D_b max.	D_b min.	r_a max.	r_b max.	
NUP332	N332	NF332	176	176	200	211	228	324	324	296	3	3	31.7
NUP332R	—	—	176	176	200	211	228	324	—	—	3	3	32.0
NUP2332	—	—	176	176	200	211	228	324	—	—	3	3	53.1
NUP2332R	—	—	176	176	200	211	228	324	—	—	3	3	53.1
—	—	—	176	176	200	211	—	324	—	—	3	3	61.5
NUP1034	—	—	181	181	190	197	—	249	—	—	2	2	7.90
NUP234	N234	NF234	186	186	204	211	223	294	294	280	3	3	18.4
NUP234R	—	—	186	186	204	211	223	294	—	—	3	3	18.6
NUP2234	—	—	186	186	204	211	223	294	—	—	3	3	29.2
NUP2234R	—	—	186	186	204	211	223	294	—	—	3	3	29.2
—	—	—	186	186	204	211	—	294	—	—	3	3	36.2
NUP334	N334	NF334	186	186	216	223	241	344	344	314	3	3	38.6
NUP2334	—	—	186	186	216	223	241	344	—	—	3	3	62.6
—	—	—	186	186	216	223	—	344	—	—	3	3	70.8
NUP1036	—	—	191	191	203	209	—	269	—	—	2	2	10.5
NUP236	N236	NF236	196	196	214	221	233	304	304	290	3	3	19.3
NUP236R	—	—	196	196	214	221	233	304	—	—	3	3	19.3
NUP2236	—	—	196	196	214	221	233	304	—	—	3	3	30.4
NUP2236R	—	—	196	196	214	221	233	304	—	—	3	3	30.4
—	—	—	196	196	214	221	—	304	—	—	3	3	38.4
NUP336	N336	NF336	196	196	227	235	255	364	364	332	3	3	42.6
NUP2336	—	—	196	196	227	235	255	364	—	—	3	3	73.0
—	—	—	196	196	227	235	—	364	—	—	3	3	84.4
NUP1038	—	—	201	201	213	219	—	279	—	—	2	2	10.9
NUP238	N238	NF238	206	206	227	234	247	324	324	310	3	3	23.2
NUP238R	—	—	206	206	227	234	247	324	—	—	3	3	23.3
NUP2238	—	—	206	206	227	234	247	324	—	—	3	3	37.0

2) Bearing numbers of NU and NJ type bearings with mounted thrust collar (refer to specification table shown after this specification table) are NUJ and NH.

Single-row cylindrical roller bearings

d (190) ~ (240) mm

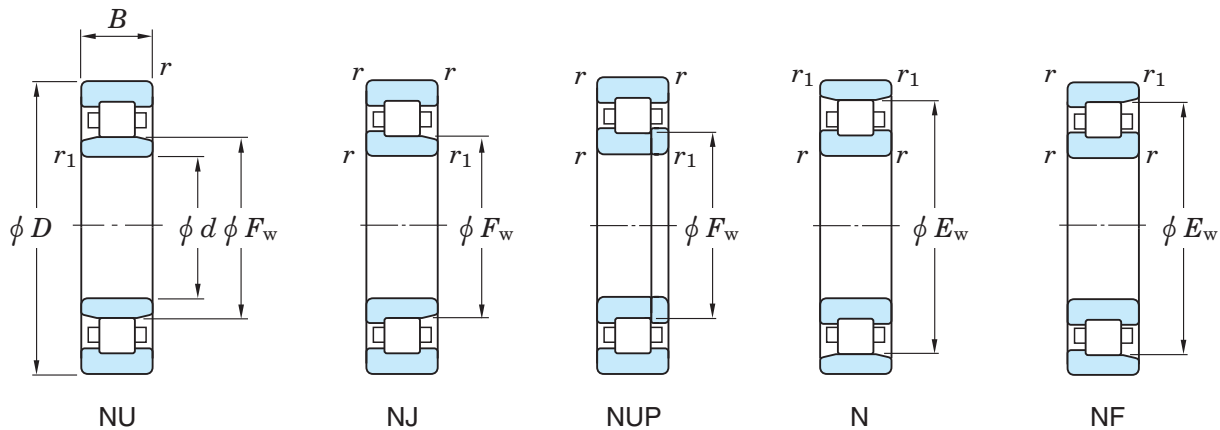

d	Boundary dimensions (mm)						Basic load ratings (kN)		Limiting speeds (min ⁻¹)		Bearing No.	
	D	B	$r_{\min.}$	$r_{1\min.}$	F_w	E_w	C_r	C_{Or}	Grease lub.	Oil lub.	NU	NJ
190	340	92	4	4	228	—	1 100	1 670	1 500	2 000	NU2238R	NJ2238R
	340	120	4	4	231	—	1 310	1 930	1 300	2 000	NU3238	—
	400	78	5	5	245	345	987	1 260	1 300	1 800	NU338	NJ338
	400	132	5	5	245	—	1 520	2 220	1 200	1 800	NU2338	NJ2338
	400	155	5	5	245	—	1 870	2 910	1 200	1 800	NU3338	—
200	310	51	2.1	2.1	229	—	388	582	1 900	2 300	NU1040	—
	360	58	4	4	244	316	618	865	1 600	1 900	NU240	NJ240
	360	58	4	4	243	—	766	1 060	1 600	1 900	NU240R	NJ240R
	360	98	4	4	244	—	946	1 490	1 400	1 900	NU2240	NJ2240
	360	98	4	4	241	—	1 220	1 870	1 400	1 900	NU2240R	NJ2240R
	360	128	4	4	244	—	1 200	2 020	1 300	1 900	NU3240	—
	420	80	5	5	260	360	987	1 270	1 200	1 700	NU340	NJ340
	420	138	5	5	260	—	1 520	2 240	1 100	1 700	NU2340	NJ2340
420	165	5	5	260	—	1 870	2 930	1 100	1 700	NU3340	—	
220	340	56	3	3	250	—	507	748	1 700	2 000	NU1044	—
	400	65	4	4	270	350	766	1 080	1 400	1 700	NU244	NJ244
	400	108	4	4	270	—	1 130	1 810	1 200	1 700	NU2244	NJ2244
	400	144	4	4	270	—	1 630	2 880	1 100	1 700	NU3244	—
	460	88	5	5	284	396	1 200	1 570	1 100	1 500	NU344	NJ344
	460	145	5	5	284	—	1 810	2 690	990	1 500	NU2344	—
	460	180	5	5	284	—	2 130	3 300	990	1 500	NU3344	—
240	360	56	3	3	270	—	535	822	1 600	1 900	NU1048	—
	440	72	4	4	295	385	949	1 340	1 200	1 500	NU248	NJ248
	440	120	4	4	295	—	1 430	2 320	1 100	1 500	NU2248	NJ2248
	440	160	4	4	295	—	1 950	3 460	990	1 500	NU3248	—
	500	95	5	5	310	430	1 430	1 950	990	1 300	NU348	NJ348
	500	155	5	5	310	—	2 170	3 320	880	1 300	NU2348	—

[Remarks] 1) Standard cage types used for the above bearings are shown in Table 1 earlier in this section. Please note that basic load ratings and limiting speeds shown above indicate the value applicable to machined cage. Consult JTEKT about bearings with pressed cage, since they may be different from bearings with machined cage in values above.

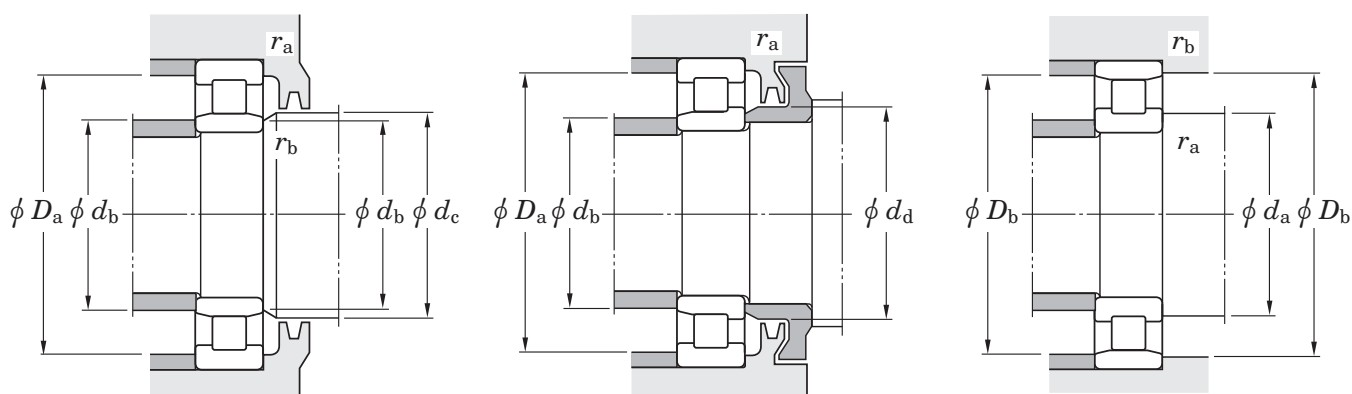

NUP	N	NF	Mounting dimensions (mm)										(Refer.) Mass NU (kg)
			d_a min.	d_b min. max.	d_c min.	d_d min.	D_a max.	D_b max. min.	r_a max.	r_b max.			
NUP2238R	—	—	206	206 227	234	247	324	— —	3 3	37.0			
—	—	—	206	206 227	234	—	324	— —	3 3	46.8			
NUP338	N338	NF338	210	210 240	248	268	380	380 349	4 4	49.9			
NUP2338	—	—	210	210 240	248	268	380	— —	4 4	84.7			
—	—	—	210	210 240	248	—	380	— —	4 4	96.5			
NUP1040	—	—	211	211 226	233	—	299	— —	2 2	14.1			
NUP240	N240	NF240	216	216 240	247	261	344	344 328	3 3	26.8			
NUP240R	—	—	216	216 240	247	261	344	— —	3 3	27.2			
NUP2240	—	—	216	216 240	247	261	344	— —	3 3	44.4			
NUP2240R	—	—	216	216 240	247	261	344	— —	3 3	44.4			
—	—	—	216	216 240	247	—	344	— —	3 3	56.2			
NUP340	N340	NF340	220	220 254	263	283	400	400 364	4 4	56.2			
NUP2340	—	—	220	220 254	263	283	400	— —	4 4	97.4			
—	—	—	220	220 250	258	—	400	— —	4 4	113			
NUP1044	—	—	233	233 248	254	—	327	— —	2.5 2.5	18.5			
NUP244	N244	NF244	236	236 266	273	289	384	384 362	3 3	38.5			
—	—	—	236	236 266	273	289	384	— —	3 3	60.9			
—	—	—	236	236 266	273	—	384	— —	3 3	78.8			
NUP344	N344	NF344	240	240 279	287	309	440	440 400	4 4	74.4			
NUP2344	—	—	240	240 276	287	—	440	— —	4 4	119			
—	—	—	240	240 279	287	—	440	— —	4 4	148			
NUP1048	—	—	253	253 268	275	—	347	— —	2.5 2.5	20.1			
NUP248	N248	NF248	256	256 293	298	316	424	424 397	3 3	52.1			
—	—	—	256	256 293	298	316	424	— —	3 3	82.5			
—	—	—	256	256 293	298	—	424	— —	3 3	107			
NUP348	N348	NF348	260	260 305	313	337	480	480 434	4 4	94.6			
NUP2348	—	—	260	260 303	313	—	480	— —	4 4	152			

2) Bearing numbers of NU and NJ type bearings with mounted thrust collar (refer to specification table shown after this specification table) are NUJ and NH.

Single-row cylindrical roller bearings

d (240) ~ 460 mm

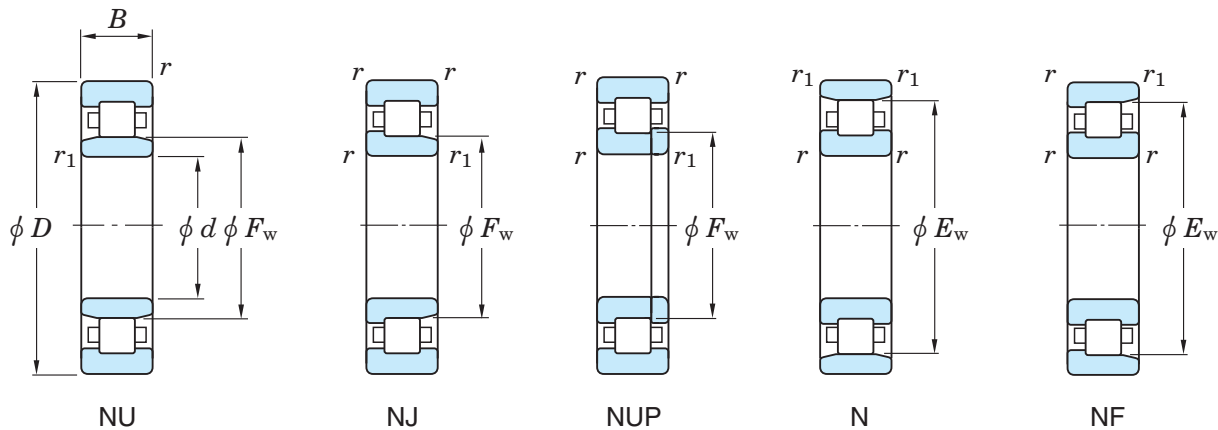

Boundary dimensions (mm)							Basic load ratings (kN)		Limiting speeds (min ⁻¹)		Bearing No.	
d	D	B	$r_{\min.}$	$r_{1\min.}$	F_w	E_w	C_r	C_{Or}	Grease lub.	Oil lub.	NU	NJ
240	500	195	5	5	310	—	2 540	4 070	880	1 300	NU3348	—
260	400	65	4	4	296	—	651	979	1 400	1 700	NU1052	—
	480	80	5	5	320	420	1 100	1 580	1 100	1 300	NU252	NJ252
	480	130	5	5	320	—	1 790	2 950	990	1 300	NU2252	NJ2252
	480	174	5	5	320	—	2 140	3 680	880	1 300	NU3252	—
	540	165	6	6	336	—	2 430	3 750	790	1 200	NU2352	—
	540	206	6	6	336	—	2 940	4 790	790	1 200	NU3352	—
280	420	65	4	4	316	—	669	1 030	1 300	1 500	NU1056	—
	500	80	5	5	340	440	1 140	1 680	1 000	1 200	NU256	NJ256
300	460	74	4	4	340	—	890	1 380	1 200	1 400	NU1060	—
	540	85	5	5	364	476	1 350	1 960	920	1 100	NU260	NJ260
320	480	74	4	4	360	—	913	1 450	1 100	1 300	NU1064	—
	580	92	5	5	390	510	1 540	2 270	840	1 000	NU264	NJ264
	670	112	7.5	7.5	425	—	1 970	2 880	650	870	NU364	—
340	520	82	5	5	385	—	1 090	1 750	980	1 200	NU1068	—
360	540	82	5	5	405	—	1 120	1 830	920	1 100	NU1072	—
380	560	82	5	5	425	—	1 150	1 920	860	1 000	NU1076	—
400	600	90	5	5	450	—	1 400	2 310	780	920	NU1080	—
420	620	90	5	5	470	—	1 390	2 320	730	860	NU1084	—
440	650	94	6	6	493	—	1 490	2 520	680	800	NU1088	—
460	680	100	6	6	516	—	1 590	2 730	630	750	NU1092	—

[Remarks] 1) Standard cage types used for the above bearings are shown in Table 1 earlier in this section. Please note that basic load ratings and limiting speeds shown above indicate the value applicable to machined cage. Consult JTEKT about bearings with pressed cage, since they may be different from bearings with machined cage in values above.

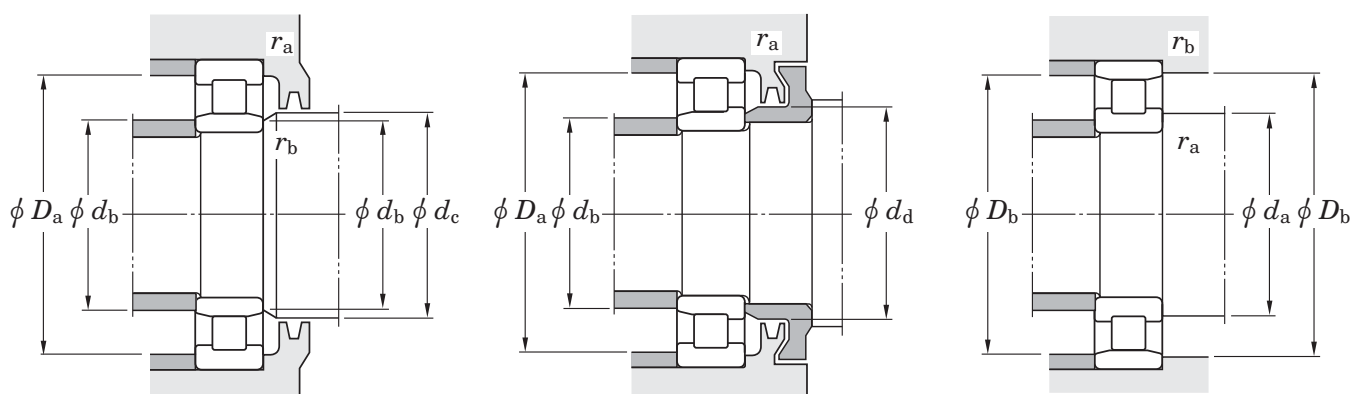

NUP	N	NF	Mounting dimensions (mm)										(Refer.) Mass NU (kg)
			d_a min.	d_b min.	d_b max.	d_c min.	d_d min.	D_a max.	D_b max.	r_a max.	r_b max.		
—	—	—	260	260	305	313	—	480	—	—	4	4	189
NUP1052	—	—	276	276	292	300	—	384	—	—	3	3	29.2
NUP252	N252	NF252	280	280	318	323	343	460	460	432	4	4	69.0
—	—	—	280	280	318	323	343	460	—	—	4	4	107
—	—	—	280	280	318	323	—	460	—	—	4	4	139
NUP2352	—	—	284	284	327	339	—	516	—	—	5	5	185
—	—	—	284	284	330	339	—	516	—	—	5	5	232
NUP1056	—	—	296	296	313	320	—	404	—	—	3	3	35.2
NUP256	N256	NF256	300	300	336	343	365	480	480	452	4	4	72.7
NUP1060	—	—	316	316	337	344	—	444	—	—	3	3	44.1
NUP260	N260	NF260	320	320	361	368	392	520	520	487	4	4	90.7
NUP1064	—	—	336	336	356	365	—	464	—	—	3	3	48.4
NUP264	N264	NF264	340	340	386	393	419	560	560	522	4	4	114
—	—	—	352	352	419	428	—	638	638	575	6	6	199
NUP1068	—	—	360	360	381	390	—	500	—	—	4	4	64.1
NUP1072	—	—	380	380	401	410	—	520	—	—	4	4	67.1
NUP1076	—	—	400	400	421	430	—	540	—	—	4	4	70.1
NUP1080	—	—	420	420	446	455	—	580	—	—	4	4	91.0
NUP1084	—	—	440	440	466	475	—	600	—	—	4	4	94.6
NUP1088	—	—	464	464	489	498	—	626	—	—	5	5	109
NUP1092	—	—	484	484	512	520	—	656	—	—	5	5	127

2) Bearing numbers of NU and NJ type bearings with mounted thrust collar (refer to specification table shown after this specification table) are NUJ and NH.

Thrust collars for cylindrical roller bearings

d 20 ~ (35) mm

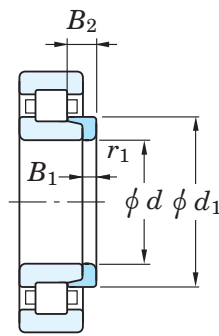

Thrust collar

Boundary dimensions (mm)					Thrust collar No.	(Refer.) Mass (kg)	Applicable bearing No.	
d	d_1	B_1	B_2	r_1 min.			NJ	NU
20	29.7	3	6.75	0.6	HJ204	0.012	NJ204	NU204
	29.8	3	5.5	0.6	HJ204R	0.011	NJ204R	NU204R
	30	3	7.5	0.6	HJ2204	0.012	NJ2204	NU2204
	29.8	3	6.5	0.6	HJ2204R	0.012	NJ2204R	NU2204R
	31.8	4	7.5	0.6	HJ304	0.017	NJ304	NU304
	31.4	4	6.5	0.6	HJ304R	0.017	NJ304R	NU304R
	31.8	4	8.5	0.6	HJ2304	0.020	NJ2304	NU2304
	31.4	4	7.5	0.6	HJ2304R	0.018	NJ2304R	NU2304R
25	34.7	3	7.25	0.6	HJ205	0.015	NJ205	NU205
	34.8	3	6	0.6	HJ205R	0.014	NJ205R	NU205R
	34.7	3	7.5	0.6	HJ2205	0.015	NJ2205	NU2205
	34.8	3	6.5	0.6	HJ2205R	0.014	NJ2205R	NU2205R
	39	4	8	1.1	HJ305	0.025	NJ305	NU305
	38.2	4	7	1.1	HJ305R	0.025	NJ305R	NU305R
	39	4	9	1.1	HJ2305	0.025	NJ2305	NU2305
	38.2	4	8	1.1	HJ2305R	0.026	NJ2305R	NU2305R
30	41.8	4	8.25	0.6	HJ206	0.025	NJ206	NU206
	41.4	4	7	0.6	HJ206R	0.025	NJ206R	NU206R
	41.8	4	8.5	0.6	HJ2206	0.025	NJ2206	NU2206
	41.4	4	7.5	0.6	HJ2206R	0.025	NJ2206R	NU2206R
	45.9	5	9.5	1.1	HJ306	0.039	NJ306	NU306
	45.1	5	8.5	1.1	HJ306R	0.042	NJ306R	NU306R
	45.9	5	11.5	1.1	HJ2306	0.039	NJ2306	NU2306
	45.1	5	9.5	1.1	HJ2306R	0.043	NJ2306R	NU2306R
	50.5	7	11.5	1.5	HJ406	0.080	NJ406	NU406
35	47.6	4	8	0.6	HJ207	0.030	NJ207	NU207
	48.2	4	7	0.6	HJ207R	0.033	NJ207R	NU207R
	47.6	4	8.5	0.6	HJ2207	0.030	NJ2207	NU2207

d (35) ~ (50) mm

d	Boundary dimensions (mm)				Thrust collar No.	(Refer.) Mass (kg)	Applicable bearing No.	
	d_1	B_1	B_2	r_1 min.			NJ	NU
35	48.2	4	8.5	0.6	HJ2207R	0.035	NJ2207R	NU2207R
	50.8	6	11	1.1	HJ307	0.056	NJ307	NU307
	51.1	6	9.5	1.1	HJ307R	0.060	NJ307R	NU307R
	50.8	6	14	1.1	HJ2307	0.056	NJ2307	NU2307
	51.1	6	11	1.1	HJ2307R	0.062	NJ2307R	NU2307R
	59	8	13	1.5	HJ407	0.120	NJ407	NU407
40	54.2	5	9	1.1	HJ208	0.046	NJ208	NU208
	54.1	5	8.5	1.1	HJ208R	0.049	NJ208R	NU208R
	54.2	5	9.5	1.1	HJ2208	0.046	NJ2208	NU2208
	54.1	5	9	1.1	HJ2208R	0.050	NJ2208R	NU2208R
	58.4	7	12.5	1.5	HJ308	0.083	NJ308	NU308
	57.7	7	11	1.5	HJ308R	0.088	NJ308R	NU308R
	58.4	7	14.5	1.5	HJ2308	0.083	NJ2308	NU2308
	57.7	7	12.5	1.5	HJ2308R	0.091	NJ2308R	NU2308R
64.8	8	13	2	HJ408	0.140	NJ408	NU408	
45	59	5	9.5	1.1	HJ209	0.053	NJ209	NU209
	59.1	5	8.5	1.1	HJ209R	0.055	NJ209R	NU209R
	59	5	9.5	1.1	HJ2209	0.053	NJ2209	NU2209
	59.1	5	9	1.1	HJ2209R	0.055	NJ2209R	NU2209R
	64	7	12.5	1.5	HJ309	0.099	NJ309	NU309
	64.5	7	11.5	1.5	HJ309R	0.110	NJ309R	NU309R
	64	7	15	1.5	HJ2309	0.099	NJ2309	NU2309
	64.5	7	13	1.5	HJ2309R	0.113	NJ2309R	NU2309R
	71.8	8	13.5	2	HJ409	0.175	NJ409	NU409
50	64.6	5	10	1.1	HJ210	0.063	NJ210	NU210
	64.1	5	9	1.1	HJ210R	0.061	NJ210R	NU210R
	64.6	5	9.5	1.1	HJ2210	0.063	NJ2210	NU2210
	64.1	5	9	1.1	HJ2210R	0.061	NJ2210R	NU2210R
	71	8	14	2	HJ310	0.142	NJ310	NU310

Thrust collars for cylindrical roller bearings

d (50) ~ (65) mm

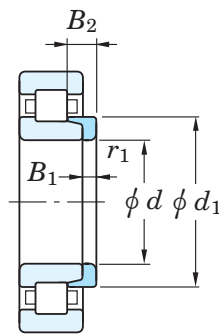

Thrust collar

Boundary dimensions (mm)					Thrust collar No.	(Refer.) Mass (kg)	Applicable bearing No.	
d	d_1	B_1	B_2	r_1 min.			NJ	NU
50	71.4	8	13	2	HJ310R	0.151	NJ310R	NU310R
	71	8	17	2	HJ2310	0.142	NJ2310	NU2310
	71.4	8	14.5	2	HJ2310R	0.155	NJ2310R	NU2310R
	78.8	9	14.5	2.1	HJ410	0.230	NJ410	NU410
55	70.8	6	11	1.1	HJ211	0.084	NJ211	NU211
	70.9	6	9.5	1.1	HJ211R	0.087	NJ211R	NU211R
	70.8	6	11	1.1	HJ2211	0.084	NJ2211	NU2211
	70.9	6	10	1.1	HJ2211R	0.088	NJ2211R	NU2211R
	77.2	9	15	2	HJ311	0.182	NJ311	NU311
	77.6	9	14	2	HJ311R	0.195	NJ311R	NU311R
	77.2	9	18.5	2	HJ2311	0.182	NJ2311	NU2311
	77.6	9	15.5	2	HJ2311R	0.200	NJ2311R	NU2311R
	85.2	10	16.5	2.1	HJ411	0.290	NJ411	NU411
60	78.4	6	11	1.5	HJ212	0.108	NJ212	NU212
	77.7	6	10	1.5	HJ212R	0.108	NJ212R	NU212R
	78.4	6	11	1.5	HJ2212	0.108	NJ2212	NU2212
	77.7	6	10	1.5	HJ2212R	0.108	NJ2212R	NU2212R
	84.2	9	15.5	2.1	HJ312	0.220	NJ312	NU312
	84.5	9	14.5	2.1	HJ312R	0.231	NJ312R	NU312R
	84.2	9	19	2.1	HJ2312	0.220	NJ2312	NU2312
	84.5	9	16	2.1	HJ2312R	0.237	NJ2312R	NU2312R
	91.8	10	16.5	2.1	HJ412	0.340	NJ412	NU412
65	84.8	6	11	1.5	HJ213	0.123	NJ213	NU213
	84.5	6	10	1.5	HJ213R	0.129	NJ213R	NU213R
	84.8	6	11.5	1.5	HJ2213	0.123	NJ2213	NU2213
	84.5	6	10.5	1.5	HJ2213R	0.131	NJ2213R	NU2213R
	91	10	17	2.1	HJ313	0.280	NJ313	NU313
	90.6	10	15.5	2.1	HJ313R	0.288	NJ313R	NU313R

d (65) ~ (80) mm

d	Boundary dimensions (mm)				Thrust collar No.	(Refer.) Mass (kg)	Applicable bearing No.	
	d_1	B_1	B_2	r_1 min.			NJ	NU
65	91	10	20	2.1	HJ2313	0.280	NJ2313	NU2313
	90.6	10	18	2.1	HJ2313R	0.298	NJ2313R	NU2313R
	98.5	11	18	2.1	HJ413	0.420	NJ413	NU413
70	89.6	7	12.5	1.5	HJ214	0.150	NJ214	NU214
	89.5	7	11	1.5	HJ214R	0.157	NJ214R	NU214R
	89.6	7	12.5	1.5	HJ2214	0.150	NJ2214	NU2214
	89.5	7	11.5	1.5	HJ2214R	0.158	NJ2214R	NU2214R
	98	10	17.5	2.1	HJ314	0.330	NJ314	NU314
	97.5	10	15.5	2.1	HJ314R	0.330	NJ314R	NU314R
	98	10	20.5	2.1	HJ2314	0.330	NJ2314	NU2314
	97.5	10	18.5	2.1	HJ2314R	0.345	NJ2314R	NU2314R
110.5	12	20	3	HJ414	0.605	NJ414	NU414	
75	94	7	12.5	1.5	HJ215	0.156	NJ215	NU215
	94.5	7	11	1.5	HJ215R	0.166	NJ215R	NU215R
	94	7	12.5	1.5	HJ2215	0.156	NJ2215	NU2215
	94.5	7	11.5	1.5	HJ2215R	0.167	NJ2215R	NU2215R
	104.2	11	18.5	2.1	HJ315	0.400	NJ315	NU315
	104.2	11	16.5	2.1	HJ315R	0.410	NJ315R	NU315R
	104.2	11	21.5	2.1	HJ2315	0.400	NJ2315	NU2315
	104.2	11	19.5	2.1	HJ2315R	0.430	NJ2315R	NU2315R
116	13	21.5	3	HJ415	0.710	NJ415	NU415	
80	101.2	8	13.5	2	HJ216	0.207	NJ216	NU216
	101.6	8	12.5	2	HJ216R	0.222	NJ216R	NU216R
	101.2	8	13.5	2	HJ2216	0.207	NJ2216	NU2216
	101.6	8	12.5	2	HJ2216R	0.222	NJ2216R	NU2216R
	111.8	11	19.5	2.1	HJ316	0.470	NJ316	NU316
	110.6	11	17	2.1	HJ316R	0.460	NJ316R	NU316R
	111.8	11	23	2.1	HJ2316	0.470	NJ2316	NU2316
	110.6	11	20	2.1	HJ2316R	0.480	NJ2316R	NU2316R

Thrust collars for cylindrical roller bearings

d (80) ~ (100) mm

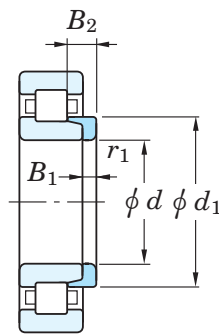

Thrust collar

Boundary dimensions (mm)					Thrust collar No.	(Refer.) Mass (kg)	Applicable bearing No.	
d	d_1	B_1	B_2	r_1 min.			NJ	NU
80	122	13	22	3	HJ416	0.780	NJ416	NU416
85	108.2	8	14	2	HJ217	0.250	NJ217	NU217
	107.6	8	12.5	2	HJ217R	0.250	NJ217R	NU217R
	108.2	8	14	2	HJ2217	0.250	NJ2217	NU2217
	107.6	8	13	2	HJ2217R	0.252	NJ2217R	NU2217R
	117.5	12	20.5	3	HJ317	0.560	NJ317	NU317
	117.9	12	18.5	3	HJ317R	0.575	NJ317R	NU317R
	117.5	12	24	3	HJ2317	0.560	NJ2317	NU2317
	117.9	12	22	3	HJ2317R	0.595	NJ2317R	NU2317R
	126	14	24	4	HJ417	0.880	NJ417	NU417
90	114.2	9	15	2	HJ218	0.305	NJ218	NU218
	114.4	9	14	2	HJ218R	0.320	NJ218R	NU218R
	114.2	9	16	2	HJ2218	0.305	NJ2218	NU2218
	114.4	9	15	2	HJ2218R	0.325	NJ2218R	NU2218R
	125	12	21	3	HJ318	0.630	NJ318	NU318
	124.2	12	18.5	3	HJ318R	0.630	NJ318R	NU318R
	125	12	26	3	HJ2318	0.630	NJ2318	NU2318
	124.2	12	22	3	HJ2318R	0.660	NJ2318R	NU2318R
	137	14	24	4	HJ418	1.05	NJ418	NU418
95	121	9	15.5	2.1	HJ219	0.352	NJ219	NU219
	120.6	9	14	2.1	HJ219R	0.355	NJ219R	NU219R
	121	9	16.5	2.1	HJ2219	0.352	NJ2219	NU2219
	120.6	9	15.5	2.1	HJ2219R	0.365	NJ2219R	NU2219R
	132	13	22.5	3	HJ319	0.760	NJ319	NU319
	132.2	13	20.5	3	HJ319R	0.785	NJ319R	NU319R
	132	13	26.5	3	HJ2319	0.760	NJ2319	NU2319
	147	15	25.5	4	HJ419	1.30	NJ419	NU419
100	128	10	17	2.1	HJ220	0.444	NJ220	NU220

d (100) ~ 120 mm

d	Boundary dimensions (mm)				Thrust collar No.	(Refer.) Mass (kg)	Applicable bearing No.	
	d_1	B_1	B_2	r_1 min.			NJ	NU
100	127.5	10	15	2.1	HJ220R	0.435	NJ220R	NU220R
	128	10	18	2.1	HJ2220	0.444	NJ2220	NU2220
	127.5	10	16	2.1	HJ2220R	0.450	NJ2220R	NU2220R
	140.5	13	22.5	3	HJ320	0.895	NJ320	NU320
	139.6	13	20.5	3	HJ320R	0.890	NJ320R	NU320R
	140.5	13	27.5	3	HJ2320	0.895	NJ2320	NU2320
	139.6	13	23.5	3	HJ2320R	0.920	NJ2320R	NU2320R
	153.5	16	27	4	HJ420	1.50	NJ420	NU420
105	135	10	17.5	2.1	HJ221	0.505	NJ221	NU221
	147	13	22.5	3	HJ321	0.970	NJ321	NU321
	159.5	16	27	4	HJ421	1.65	NJ421	NU421
110	141.5	11	18.5	2.1	HJ222	0.615	NJ222	NU222
	141.7	11	17	2.1	HJ222R	0.620	NJ222R	NU222R
	141.5	11	20.5	2.1	HJ2222	0.615	NJ2222	NU2222
	141.7	11	19.5	2.1	HJ2222R	0.645	NJ2222R	NU2222R
	155.5	14	23	3	HJ322	1.17	NJ322	NU322
	155.8	14	22	3	HJ322R	1.21	NJ322R	NU322R
	155.5	14	28	3	HJ2322	1.17	NJ2322	NU2322
	155.8	14	26.5	3	HJ2322R	1.27	NJ2322R	NU2322R
	171	17	29.5	4	HJ422	2.10	NJ422	NU422
120	153	11	19	2.1	HJ224	0.715	NJ224	NU224
	153.4	11	17	2.1	HJ224R	0.710	NJ224R	NU224R
	153	11	22	2.1	HJ2224	0.715	NJ2224	NU2224
	153.4	11	20	2.1	HJ2224R	0.745	NJ2224R	NU2224R
	168.5	14	23.5	3	HJ324	1.40	NJ324	NU324
	168.6	14	22.5	3	HJ324R	1.41	NJ324R	NU324R
	168.5	14	28	3	HJ2324	1.40	NJ2324	NU2324
	168.6	14	26	3	HJ2324R	1.46	NJ2324R	NU2324R
	188	17	30.5	5	HJ424	2.60	NJ424	NU424

Thrust collars for cylindrical roller bearings

d 130 ~ (160) mm

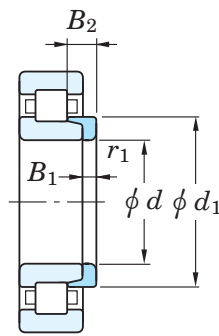

Thrust collar

Boundary dimensions (mm)					Thrust collar No.	(Refer.) Mass (kg)	Applicable bearing No.	
d	d_1	B_1	B_2	r_1 min.			NJ	NU
130	165.5	11	19	3	HJ226	0.840	NJ226	NU226
	164.2	11	17	3	HJ226R	0.790	NJ226R	NU226R
	165.5	11	25	3	HJ2226	0.840	NJ2226	NU2226
	164.2	11	21	3	HJ2226R	0.840	NJ2226R	NU2226R
	182	14	24	4	HJ326	1.62	NJ326	NU326
	182.3	14	23	4	HJ326R	1.65	NJ326R	NU326R
	182	14	29.5	4	HJ2326	1.62	NJ2326	NU2326
	182.3	14	28	4	HJ2326R	1.73	NJ2326R	NU2326R
	205	18	32	5	HJ426	3.30	NJ426	NU426
140	179.5	11	19	3	HJ228	1.00	NJ228	NU228
	180	11	18	3	HJ228R	0.990	NJ228R	NU228R
	179.5	11	25	3	HJ2228	1.00	NJ2228	NU2228
	180	11	23	3	HJ2228R	1.07	NJ2228R	NU2228R
	196	15	26	4	HJ328	1.93	NJ328	NU328
	196	15	25	4	HJ328R	2.04	NJ328R	NU328R
	196	15	33.5	4	HJ2328	1.98	NJ2328	NU2328
	196	15	31	4	HJ2328R	2.14	NJ2328R	NU2328R
	219	18	33	5	HJ428	3.75	NJ428	NU428
150	193	12	20.5	3	HJ230	1.24	NJ230	NU230
	193.7	12	19.5	3	HJ230R	1.26	NJ230R	NU230R
	193	12	26.5	3	HJ2230	1.24	NJ2230	NU2230
	193.7	12	24.5	3	HJ2230R	1.35	NJ2230R	NU2230R
	210	15	26.5	4	HJ330	2.37	NJ330	NU330
	210	15	25	4	HJ330R	2.35	NJ330R	NU330R
	210	15	34	4	HJ2330	2.37	NJ2330	NU2330
	210	15	31.5	4	HJ2330R	2.48	NJ2330R	NU2330R
	234	20	36.5	5	HJ430	4.70	NJ430	NU430
160	207	12	21	3	HJ232	1.48	NJ232	NU232
	207.3	12	20	3	HJ232R	1.48	NJ232R	NU232R

d (160) ~ (200) mm

d	Boundary dimensions (mm)				Thrust collar No.	(Refer.) Mass (kg)	Applicable bearing No.	
	d_1	B_1	B_2	r_1 min.			NJ	NU
160	205	12	28	3	HJ2232	1.48	NJ2232	NU2232
	206.1	12	24.5	3	HJ2232R	1.55	NJ2232R	NU2232R
	225	15	28	4	HJ332	2.75	NJ332	NU332
	222.1	15	25	4	HJ332R	2.59	NJ332R	NU332R
	225	15	37	4	HJ2332	2.75	NJ2332	NU2332
	222.1	15	32	4	HJ2332R	2.76	NJ2332R	NU2332R
170	220.5	12	22	4	HJ234	1.70	NJ234	NU234
	220.8	12	20	4	HJ234R	1.70	NJ234R	NU234R
	219	12	29	4	HJ2234	1.70	NJ2234	NU2234
	219.5	12	24	4	HJ2234R	1.79	NJ2234R	NU2234R
	238	16	29.5	4	HJ334	3.25	NJ334	NU334
	238	16	38.5	4	HJ2334	3.25	NJ2334	NU2334
180	230.5	12	22	4	HJ236	1.80	NJ236	NU236
	230.8	12	20	4	HJ236R	1.79	NJ236R	NU236R
	229	12	29	4	HJ2236	1.80	NJ2236	NU2236
	229.5	12	24	4	HJ2236R	1.88	NJ2236R	NU2236R
	252	17	30.5	4	HJ336	3.85	NJ336	NU336
	252	17	40	4	HJ2336	3.85	NJ2336	NU2336
190	244.5	13	23.5	4	HJ238	2.20	NJ238	NU238
	244.5	13	21.5	4	HJ238R	2.19	NJ238R	NU238R
	243	13	31.5	4	HJ2238	2.20	NJ2238	NU2238
	243.2	13	26.5	4	HJ2238R	2.31	NJ2238R	NU2238R
	265	18	32	5	HJ338	4.45	NJ338	NU338
	265	18	41.5	5	HJ2338	4.45	NJ2338	NU2338
200	258	14	25	4	HJ240	2.60	NJ240	NU240
	258.2	14	23	4	HJ240R	2.65	NJ240R	NU240R
	258	14	34	4	HJ2240	2.60	NJ2240	NU2240
	256.9	14	28	4	HJ2240R	2.78	NJ2240R	NU2240R
	280	18	33	5	HJ340	5.00	NJ340	NU340

Thrust collars for cylindrical roller bearings

d (200) ~ 320 mm

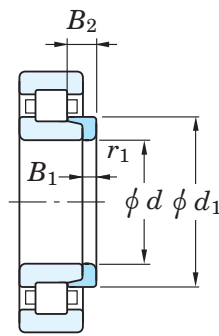

Thrust collar

Boundary dimensions (mm)					Thrust collar No.	(Refer.) Mass (kg)	Applicable bearing No.	
d	d_1	B_1	B_2	r_1 min.			NJ	NU
200	280	18	44.5	5	HJ2340	5.00	NJ2340	NU2340
220	286	15	27.5	4	HJ244	3.55	NJ244	NU244
	286	15	36.5	4	HJ2244	3.55	NJ2244	NU2244
	307	20	36	5	HJ344	7.05	NJ344	NU344
240	313	16	29.5	4	HJ248	4.65	NJ248	NU248
	313	16	38.5	4	HJ2248	4.65	NJ2248	NU2248
	335	22	39.5	5	HJ348	8.20	NJ348	NU348
260	340	18	33	5	HJ252	6.20	NJ252	NU252
	340	18	40.5	5	HJ2252	6.20	NJ2252	NU2252
280	360	18	33	5	HJ256	7.15	NJ256	NU256
300	387	20	34.5	5	HJ260	7.40	NJ260	NU260
320	415	21	37	5	HJ264	11.3	NJ264	NU264



Double-row cylindrical roller bearings

d 25 ~ (110) mm

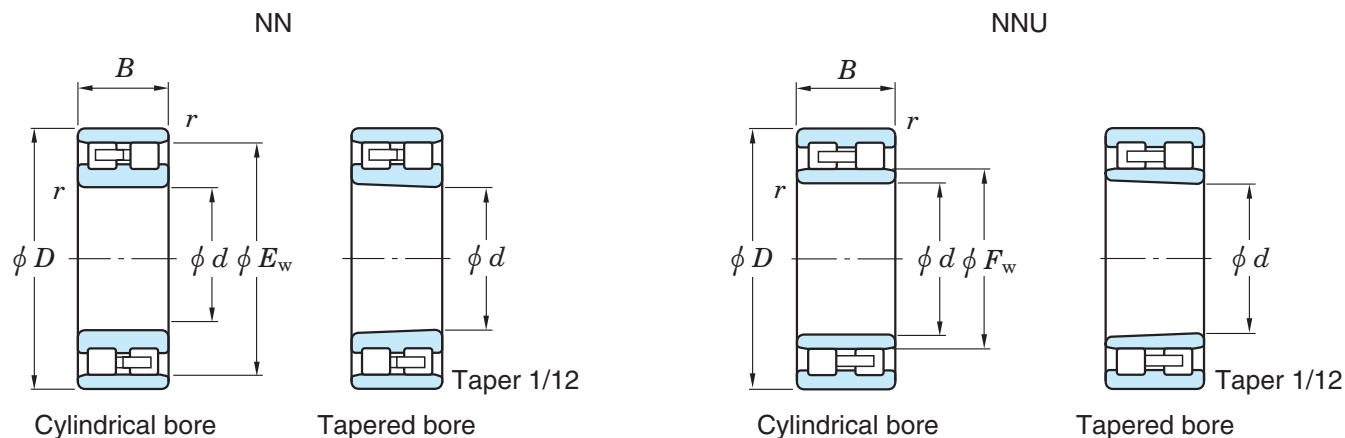

Boundary dimensions (mm)						Basic load ratings (kN)		Limiting speeds (min ⁻¹)		Bearing No. NN	
d	D	B	$r_{\min.}$	F_w	E_w	C_r	C_{0r}	Grease lub.	Oil lub.	Cylindrical bore	Tapered bore
25	47	16	0.6	—	41.3	25.7	30.0	14 000	17 000	NN3005	NN3005K
30	55	19	1	—	48.5	36.8	44.1	12 000	14 000	NN3006	NN3006K
35	62	20	1	—	55	39.1	50.0	10 000	12 000	NN3007	NN3007K
40	68	21	1	—	61	41.3	55.9	9 100	11 000	NN3008	NN3008K
45	75	23	1	—	67.5	53.4	71.9	8 300	9 900	NN3009	NN3009K
50	80	23	1	—	72.5	52.8	72.6	7 600	9 100	NN3010	NN3010K
55	90	26	1.1	—	81	71.2	101	6 800	8 200	NN3011	NN3011K
60	95	26	1.1	—	86.1	72.8	106	6 400	7 700	NN3012	NN3012K
65	100	26	1.1	—	91	74.5	111	6 000	7 200	NN3013	NN3013K
70	110	30	1.1	—	100	96.9	148	5 500	6 500	NN3014	NN3014K
75	115	30	1.1	—	105	99.0	155	5 200	6 200	NN3015	NN3015K
80	125	34	1.1	—	113	119	186	4 800	5 800	NN3016	NN3016K
85	130	34	1.1	—	118	121	194	4 600	5 500	NN3017	NN3017K
90	140	37	1.5	—	127	142	228	4 200	5 100	NN3018	NN3018K
95	145	37	1.5	—	132	150	246	4 100	4 900	NN3019	NN3019K
100	140	40	1.1	113	—	139	258	4 000	4 800	—	—
	150	37	1.5	—	137	157	265	3 900	4 700	NN3020	NN3020K
105	145	40	1.1	118	—	157	306	3 900	4 600	—	—
	160	41	2	—	146	197	322	3 700	4 400	NN3021	NN3021K
110	150	40	1.1	123	—	163	326	3 700	4 500	—	—

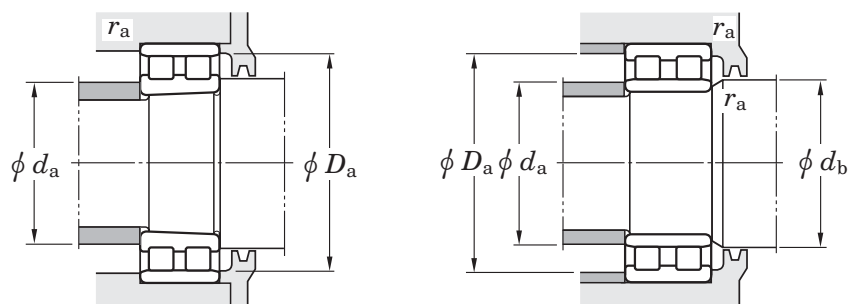

NNU		Mounting dimensions (mm)						(Refer.) Mass (kg)	
		d_a		d_b		D_a		Cylindrical bore	Tapered bore
Cylindrical bore	Tapered bore	min.	max.	min.	max.	min.	max.		
—	—	29	—	—	43	42	0.6	0.127	0.123
—	—	35	—	—	50	49	1	0.198	0.192
—	—	40	—	—	57	56	1	0.253	0.246
—	—	45	—	—	63	62	1	0.307	0.298
—	—	50	—	—	70	69	1	0.404	0.382
—	—	55	—	—	75	74	1	0.429	0.415
—	—	61.5	—	—	83.5	82	1	0.637	0.618
—	—	66.5	—	—	88.5	87	1	0.685	0.664
—	—	71.5	—	—	93.5	92	1	0.728	0.705
—	—	76.5	—	—	103.5	101	1	1.04	1.02
—	—	81.5	—	—	108.5	106	1	1.11	1.08
—	—	86.5	—	—	118.5	114	1	1.55	1.50
—	—	91.5	—	—	123.5	119	1	1.63	1.58
—	—	98	—	—	132	129	1.5	2.07	2.01
—	—	103	—	—	137	134	1.5	2.17	2.10
NNU4920	NNU4920K	106.5	111	115	133.5	—	1	1.95	1.87
—	—	108	—	—	142	139	1.5	2.28	2.21
NNU4921	NNU4921K	111.5	116	120	138.5	—	1	2.00	1.91
—	—	114	—	—	151	148	2	2.88	2.81
NNU4922	NNU4922K	116.5	121	125	143.5	—	1	2.10	2.01

Double-row cylindrical roller bearings

d (110) ~ (260) mm

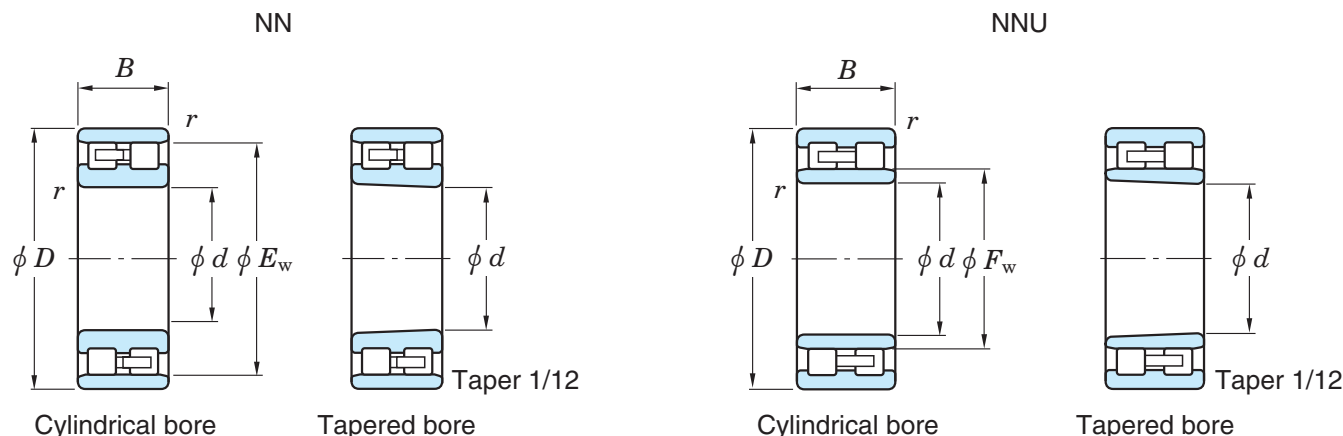

Boundary dimensions (mm)						Basic load ratings (kN)		Limiting speeds (min ⁻¹)		Bearing No. NN	
d	D	B	$r_{\min.}$	F_w	E_w	C_r	C_{0r}	Grease lub.	Oil lub.	Cylindrical bore	Tapered bore
110	170	45	2	—	155	221	361	3 500	4 200	NN3022	NN3022K
120	165	45	1.1	134.5	—	187	373	3 400	4 000	—	—
	180	46	2	—	165	232	392	3 200	3 900	NN3024	NN3024K
130	180	50	1.5	146	—	216	428	3 100	3 700	—	—
	200	52	2	—	182	283	476	2 900	3 500	NN3026	NN3026K
140	190	50	1.5	156	—	222	456	2 900	3 500	—	—
	210	53	2	—	192	297	516	2 700	3 300	NN3028	NN3028K
150	210	60	2	168.5	—	343	692	2 600	3 100	—	—
	225	56	2.1	—	206	334	587	2 500	3 000	NN3030	NN3030K
160	220	60	2	178.5	—	340	695	2 500	3 000	—	—
	240	60	2.1	—	219	398	695	2 400	2 800	NN3032	NN3032K
170	230	60	2	188.5	—	361	763	2 300	2 800	—	—
	260	67	2.1	—	236	471	824	2 200	2 600	NN3034	NN3034K
180	250	69	2	202	—	458	964	2 100	2 600	—	—
	280	74	2.1	—	255	561	958	2 000	2 400	NN3036	NN3036K
190	260	69	2	210	—	465	996	2 000	2 400	—	—
	290	75	2.1	—	265	598	1 020	1 900	2 300	NN3038	NN3038K
200	280	80	2.1	223	—	509	1 050	1 900	2 300	—	—
	310	82	2.1	—	282	638	1 120	1 700	2 100	NN3040	NN3040K
220	300	80	2.1	244	—	561	1 220	1 700	2 000	—	—
	340	90	3	—	310	752	1 370	1 600	1 900	NN3044	NN3044K
240	320	80	2.1	263	—	588	1 340	1 600	1 900	—	—
	360	92	3	—	330	864	1 590	1 400	1 700	NN3048	NN3048K
260	360	100	2.1	287	—	941	2 050	1 400	1 700	—	—

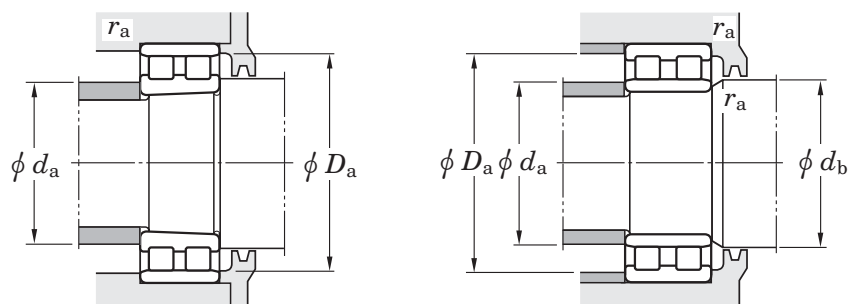

NNU		Mounting dimensions (mm)						(Refer.) Mass (kg)	
Cylindrical bore	Tapered bore	d_a		d_b		D_a	r_a	Cylindrical bore	Tapered bore
		min.	max.	min.	max.				
—	—	119	—	—	161	157	2	3.65	3.56
NNU4924	NNU4924K	126.5	132	137	158.5	—	1	2.90	2.77
		129	—	—	171	167	2	4.00	3.87
NNU4926	NNU4926K	138	143.5	148	172	—	1.5	3.90	3.73
		139	—	—	191	183	2	5.94	5.76
NNU4928	NNU4928K	148	153.5	158	182	—	1.5	4.15	3.97
		149	—	—	201	194	2	6.41	6.21
NNU4930	NNU4930K	159	166	171	201	—	2	6.50	6.22
		161	—	—	214	208	2	7.74	7.50
NNU4932	NNU4932K	169	176	182	211	—	2	6.95	6.65
		171	—	—	229	221	2	9.38	9.08
NNU4934	NNU4934K	179	186	192	221	—	2	7.20	6.88
		181	—	—	249	238	2	12.8	12.4
NNU4936	NNU4936K	189	199.5	205	241	—	2	10.5	10.1
		191	—	—	269	257	2	16.8	16.3
NNU4938	NNU4938K	199	207	215	251	—	2	11.0	10.5
		201	—	—	279	267	2	17.6	17.1
NNU4940	NNU4940K	211	219.5	228	269	—	2	15.4	14.7
		211	—	—	299	285	2	22.5	21.8
NNU4944	NNU4944K	231	241	248	289	—	2	16.7	16.0
		233	—	—	327	313	2.5	29.3	28.4
NNU4948	NNU4948K	251	260	269	309	—	2	18.0	17.2
		253	—	—	347	333	2.5	32.8	31.8
NNU4952	NNU4952K	271	284	296	349	—	2	31.4	30.0

Double-row cylindrical roller bearings

d (260) ~ 480 mm

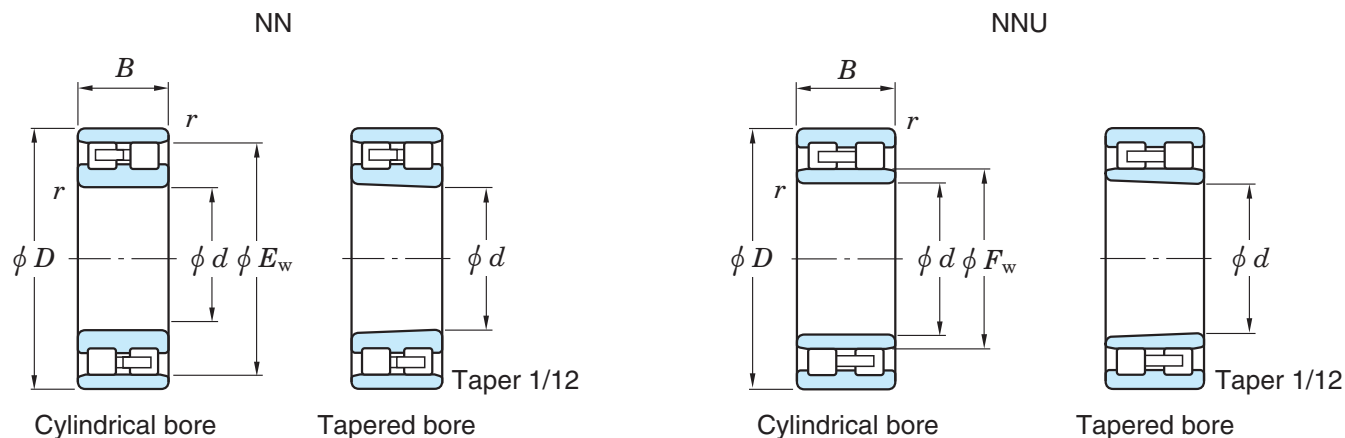

Boundary dimensions (mm)						Basic load ratings (kN)		Limiting speeds (min ⁻¹)		Bearing No. NN	
d	D	B	$r_{\min.}$	F_w	E_w	C_r	C_{0r}	Grease lub.	Oil lub.	Cylindrical bore	Tapered bore
260	400	104	4	—	364	1 030	1 830	1 300	1 500	NN3052	NN3052K
	420	106	4	—	384	1 090	2 010	1 200	1 400	NN3056	NN3056K
300	420	118	3	339	—	1 170	2 720	1 100	1 300	—	—
	460	118	4	—	418	1 290	2 460	1 100	1 300	NN3060	NN3060K
320	440	118	3	352	—	1 220	2 750	1 100	1 300	—	—
	480	121	4	—	438	1 350	2 670	980	1 200	NN3064	NN3064K
340	460	118	3	372	—	1 270	2 930	990	1 200	—	—
	520	133	5	—	473	1 580	3 090	880	1 100	NN3068	NN3068K
360	540	134	5	—	493	1 560	3 090	830	990	NN3072	NN3072K
380	560	135	5	—	510	1 650	3 350	780	940	NN3076	NN3076K
400	600	148	5	—	548	2 030	4 140	700	850	NN3080	NN3080K
420	620	150	5	—	570	2 310	4 570	670	800	NN3084	NN3084K
440	650	157	6	—	597	2 520	5 060	620	740	NN3088	NN3088K
460	680	163	6	—	627	2 700	5 480	570	690	NN3092	NN3092K
480	700	165	6	—	642	2 770	5 710	540	650	NN3096	NN3096K

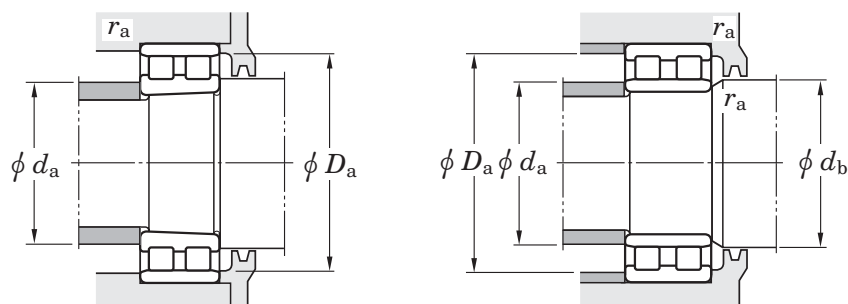

NNU		Mounting dimensions (mm)						(Refer.) Mass (kg)	
Cylindrical bore	Tapered bore	d_a		d_b		D_a		Cylindrical bore	Tapered bore
		min.	max.	min.	max.	min.	max.		
—	—	276	—	—	384	367	3	47.4	46.0
NNU4956	NNU4956K	291	305	316	369	—	2	33.1	31.6
		296	—	—	404	387	3	51.2	49.6
NNU4960	NNU4960K	313	335	343	407	—	2.5	51.9	49.7
		316	—	—	444	421	3	70.8	68.7
NNU4964	NNU4964K	333	348	363	427	—	2.5	53.7	51.4
		336	—	—	464	442	3	76.4	74.0
NNU4968	NNU4968K	353	368	383	447	—	2.5	56.8	54.3
		360	—	—	500	477	4	101	97.8
—	—	380	—	—	520	497	4	107	104
—	—	400	—	—	540	514	4	113	109
—	—	420	—	—	580	552	4	146	141
—	—	440	—	—	600	574	4	154	149
—	—	464	—	—	626	602	5	177	171
—	—	484	—	—	656	632	5	201	195
—	—	504	—	—	676	647	5	211	204

KOYO



Tapered roller bearings

Tapered roller bearings are designed such that outer ring, inner ring and rollers have tapered surfaces whose apexes converge at a common point on the bearing axis. Along with metric series bearings, inch series bearings are also available.

This type of bearing is suitable for applications that involve heavy or impact loading.

Single-row tapered roller bearings

- Able to carry radial and axial load in one direction simultaneously.

Because an axial component of force is produced when this type of bearing is loaded radially, two bearings are used together facing one another, or two or more bearings are matched and used.

- There are the standard, medium and steep type which are different in contact angle size.

Medium-tapered metric series bearings are identified by the supplementary code "C" which is added as a suffix to bearing numbers.

- Bearings whose outer ring width, outer ring small inside diameter and contact angle are determined in accordance with ISO 355 specifications are identified by the supplementary code "J" as a suffix.

Inner ring assemblies and the outer rings of such bearings are interchangeable with those of bearings produced abroad if the bearing numbers are the same.

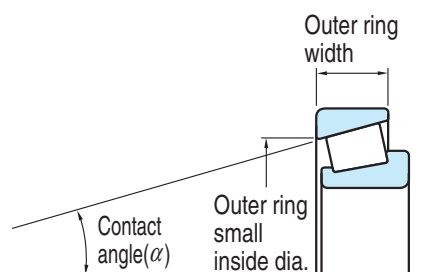

ISO sub-unit specifications

Double-row tapered roller bearings

- These bearings are divided into the TDO type which has one double outer ring and two single-row inner rings, and the TDI type which has two single-row outer rings and one double inner ring. Both accommodate radial and axial loading in both directions.

These two also carry moment loads, however, the TDO type is superior to the TDI type, because the distance between load centers (α) is longer in the TDO type.

- The spacer of the TDO type, or the TDI type, pre-adjusts the internal clearance to provide proper operating clearance after mounting.

Single-row tapered roller bearings



Metric series

Bore diameter **15 – 360** mm



Inch series

(including J series metric bearing)

Bore diameter **9.525 – 292.100** mm

Double-row tapered roller bearings

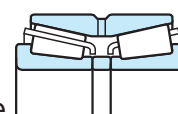

TDO type

Bore diameter **25 – 500** mm

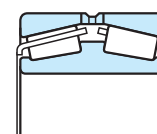

TDI type

Bore diameter **100 – 500** mm

[Note] When supplementary code "J" is added as a prefix (not a suffix) to bearing numbers (e.g. JHM720249/JHM720210), the bearings are not designed according to ISO 355. Such bearings are called "J series metric tapered roller bearings," and are produced according to special tolerances.

Boundary dimensions

Metric single-row tapered roller bearings : as specified in JIS B 1512.

Reference JIS B 1512 specifies new dimension series which are based on ISO 355, as well as the conventional "3XX" dimension series. These new dimension series are as follows :

New dimension series

(1) Angle series

Angle series	Contact angle α	
	over	up to
2	10°	13° 52'
3	13° 52'	15° 59'
4	15° 59'	18° 55'
5	18° 55'	23°
6	23°	27°
7	27°	30°

(3) Width series

Width series	$T/\{(D-d)^{0.95}\}$	
	over	up to
B	0.50	0.68
C	0.68	0.80
D	0.80	0.88
E	0.88	1.00

(2) Diameter series

Diameter series	$D/(d^{0.77})$	
	over	up to
B	3.40	3.80
C	3.80	4.40
D	4.40	4.70
E	4.70	5.00
F	5.00	5.60
G	5.60	7.00

[Remarks]

1. Combine these series symbols in the listed order to make the dimension series numbers. (ex. 2BC)
2. Bearing numbers consist of a dimension series number and a bore diameter which is added as a suffix. (ex. 2BC080 : bore diameter 80 mm)

Tolerances

- Metric series single-row tapered roller bearings as specified in JIS B 1514-1. (refer to Table 7-5 on pp. A 60 – A 62.)
- Metric series double-row tapered roller bearings as specified in BAS 1002. (refer to Table 7-6 on p. A 63.)
- Inch series tapered roller bearings as specified in ABMA Section 19. (refer to Table 7-7 on pp. A 64, 65.)
- J series metric tapered roller bearings the tolerance is specified separately. (refer to Table 7-8 on pp. A 66, 67.)

Internal clearance

Radial internal clearance of double-row, four-row and matched pair tapered roller bearings (refer to Table 10-10 on p. A 104.)

Recommended fits

- Metric series tapered roller bearings (classes 0, 6X and 6) (refer to Table 9-4 on pp. A 85, 86.)
- Inch series tapered roller bearings (refer to Table 9-7 on pp. A 90, 91.)
- J series metric tapered roller bearings (refer to Table 9-6 on pp. A 88, 89.)

Standard cage

Pressed steel cage (supplementary code : //)
 (Some large size bearings have a pin type cage (FP) instead.)
 (They are listed separately in the bearing specification table.)

Allowable misalignment	Single-row tapered roller bearings : 0.000 9 rad (3') (If the misalignment exceeds this angle size, JTEKT is ready to design special bearings to order.)
Equivalent radial load [Note] Refer to the bearing specification table for the values of axial load factors Y_1, Y_2, Y_3 and Y_0 and constant e .	<p> ■ Single-row tapered roller bearings Dynamic equivalent radial load $\left(\text{when } \frac{F_a}{F_r} \leq e \right) P_r = F_r$ $\left(\text{when } \frac{F_a}{F_r} > e \right) P_r = 0.4F_r + Y_1 F_a$ Static equivalent radial load $P_{0r} = 0.5F_r + Y_0 F_a$ when $P_{0r} < F_r, P_{0r} = F_r$ </p> <p> ■ Double-row or four-row tapered roller bearings Dynamic equivalent radial load $\left(\text{when } \frac{F_a}{F_r} \leq e \right) P_r = F_r + Y_2 F_a$ $\left(\text{when } \frac{F_a}{F_r} > e \right) P_r = 0.67F_r + Y_3 F_a$ Static equivalent radial load $P_{0r} = F_r + Y_0 F_a$ </p>

- [Remarks]
- When two single-row tapered roller bearings are used together facing one another, an axial component of force is produced under radial load.
In this case, refer to pp. A 34, 35 for calculation of the dynamic equivalent radial load.
 - When the load is too small, slippage occurs between the rollers and raceways, causing smearing to develop. This also occurs to matched pair bearings when the ratio of axial load to radial load exceeds the value e shown in the specification table ($F_a / F_r > e$).
Consult with JTEKT on use of bearings under such conditions.

Single-row tapered roller bearings metric series

d 15 ~ 22 mm

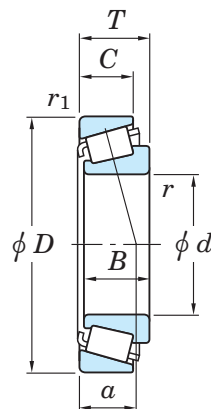

d	Boundary dimensions (mm)						Basic load ratings (kN)		Limiting speeds (min^{-1})		Bearing No. ¹⁾
	D	T	B	C	r min.	r_1 min.	C_r	C_{0r}	Grease lub.	Oil lub.	
15	35	11.75	11	10	0.6	0.6	15.8	14.5	12 000	16 000	30202R
	42	14.25	13	11	1	1	21.9	19.2	10 000	14 000	30302JR
17	40	13.25	12	11	1	1	20.8	20.7	10 000	14 000	30203JR
	40	17.25	16	14	1	1	27.4	27.5	10 000	14 000	32203JR
	47	15.25	14	12	1	1	27.4	24.5	9 200	12 000	30303JR
	47	15.25	14	12	1	1	27.4	24.5	9 200	12 000	30303R
	47	20.25	19	16	1	1	31.9	29.9	9 400	13 000	32303
	47	20.25	19	16	1	1	36.6	35.9	9 400	13 000	32303JR
20	42	15	15	12	0.6	0.6	27.3	31.5	9 700	13 000	32004JR
	47	15.25	14	12	1	1	25.8	25.5	9 000	12 000	57008R
	47	15.25	14	12	1	1	27.0	27.2	8 700	12 000	30204JR
	47	19.25	18	15	1	1	33.1	34.7	8 900	12 000	32204JR
	47	19.25	18	16	1	1	33.3	37.0	9 100	12 000	32204XR
	52	16.25	16	12	1.5	1.5	30.5	28.4	8 300	11 000	30304AC
	52	16.25	16	13	1.5	1.5	36.2	35.1	8 300	11 000	30304AJR
	52	22.25	21	18	1.5	1.5	41.8	44.9	8 600	12 000	32304CR
	52	22.25	21	18	1.5	1.5	45.1	46.7	8 400	11 000	32304JR
22	44	15	15	11.5	0.6	0.6	28.3	33.6	9 100	12 000	320/22JR
	47	17	17.5	13.5	1	1	32.7	35.9	8 700	12 000	T2CC022
	50	15.25	14	12	1	1	29.2	28.6	8 400	11 000	302/22CR
	50	15.25	14	12	1	1	29.3	30.9	8 100	11 000	302/22R
	50	19.25	18	15	1	1	35.1	39.1	8 400	11 000	322/22CR
	50	19.25	18	15	1	1	36.8	41.6	8 100	11 000	322/22R
	56	17.25	16	13	1.5	1.5	36.3	36.6	7 700	10 000	303/22XR
	56	17.25	16	14	1.5	1.5	41.7	41.1	7 500	10 000	303/22R
	56	22.25	21	17	1.5	1.5	48.3	50.6	8 000	11 000	323/22CR
	56	22.25	21	18	1.5	1.5	50.6	52.7	7 600	10 000	323/22R

[Note] 1) Please consult with JTEKT when using the bearings identified by suffix C. They are medium-tapered types especially designed for special purposes.

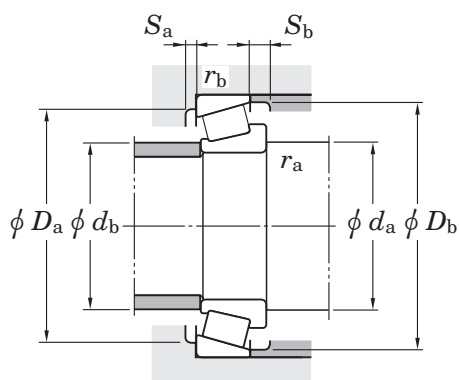

Dimension series to ISO355 (Refer.)	Load center (mm) a	Mounting dimensions (mm)										Constant e	Axial load factors		(Refer.) Mass (kg)
		d_a min.	d_b max.	D_a max.	D_b min.	S_a min.	S_b min.	r_a max.	r_b max.	Y_1	Y_0				
—	8.3	19.5	20	30.5	29	33	2	1.7	0.6	0.6	0.32	1.88	1.04	0.054	
2FB	10.0	20.5	22	36.5	35	38	2	3	1	1	0.29	2.11	1.16	0.098	
2DB	10.1	22.5	23	34.5	33	37	2	2	1	1	0.35	1.74	0.96	0.081	
2DD	11.4	22.5	23	34.5	33	37	2	3	1	1	0.31	1.92	1.06	0.104	
2FB	11.0	22.5	25	41.5	40	42	2	3	1	1	0.29	2.11	1.16	0.133	
—	10.5	22.5	25	41.5	40	42	2	3	1	1	0.28	2.11	1.16	0.127	
—	12.4	22.5	25	41.5	39	43	2	4	1	1	0.28	2.11	1.16	0.170	
2FD	12.2	22.5	25	41.5	39	43	2	4	1	1	0.29	2.11	1.16	0.176	
3CC	10.5	24.5	25	37.5	35	39	3	3	0.6	0.6	0.37	1.60	0.88	0.102	
—	12.9	25.5	26	41.5	37	44	2	3	1	1	0.52	1.16	0.64	0.125	
2DB	11.8	25.5	27	41.5	39	44	2	3	1	1	0.35	1.74	0.96	0.127	
2DD	12.5	25.5	27	41.5	39	43	2	4	1	1	0.33	1.81	1.00	0.159	
—	15.3	25.5	25	41.5	35	45	2	3	1	1	0.55	1.10	0.60	0.170	
—	13.5	28.5	28	43.5	42	49	4	4	1.5	1.5	0.55	1.10	0.60	0.170	
—	11.1	28.5	28	44	44	47	2	3	1.5	1.5	0.30	2.00	1.10	0.179	
—	16.5	28.5	25	43.5	37	48	3	4	1.5	1.5	0.55	1.10	0.60	0.250	
2FD	14.4	28.5	27	43.5	43	47	3	4	1.5	1.5	0.30	2.00	1.10	0.244	
3CC	11.0	26.5	27	39.5	38	41	3	3.5	0.6	0.6	0.40	1.51	0.83	0.108	
2CC	11.3	27.5	28	41.5	40	44	4	3.5	1	1	0.33	1.79	0.99	0.138	
—	13.9	27.5	28	44.5	40	47	2	3	1	1	0.55	1.10	0.60	0.140	
—	12.2	27.5	30	44.5	41	46	2	3	1	1	0.37	1.60	0.88	0.144	
—	15.5	27.5	28	44.5	38	47	2	4	1	1	0.55	1.10	0.60	0.170	
—	14.0	27.5	29	44.5	41	46	2	4	1	1	0.37	1.60	0.88	0.178	
—	15.7	30.5	31	47.5	44	52	3	4	1.5	1.5	0.59	1.02	0.56	0.210	
—	12.2	30.5	32	47.5	47	51	2	3	1.5	1.5	0.31	1.97	1.08	0.216	
—	16.9	30.5	28	47.5	41	52	3	5	1.5	1.5	0.55	1.10	0.60	0.290	
—	14.6	30.5	31	47.5	46	51	3	4	1.5	1.5	0.31	1.97	1.08	0.273	

Single-row tapered roller bearings metric series

d 25 ~ (30) mm

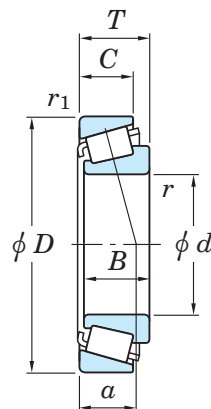

d	Boundary dimensions (mm)						Basic load ratings (kN)		Limiting speeds (min ⁻¹)		Bearing No. ¹⁾
	D	T	B	C	r min.	r_1 min.	C_r	C_{0r}	Grease lub.	Oil lub.	
25	47	15	15	11.5	0.6	0.6	30.2	37.7	8 300	11 000	32005JR
	47	17	17	14	0.6	0.6	33.5	42.3	8 300	11 000	33005JR
	52	16.25	15	12	1	1	30.4	32.4	7 900	11 000	30205XR
	52	16.25	15	13	1	1	31.5	33.7	7 800	10 000	30205JR
	52	19.25	18	16	1	1	36.4	43.2	7 900	11 000	32205XR
	52	19.25	18	16	1	1	39.8	44.8	7 900	11 000	32205JR
	52	22	22	18	1	1	48.9	58.5	7 900	10 000	33205JR
	62	18.25	17	13	1.5	1.5	39.8	42.5	5 700	8 000	30305DJR
	62	18.25	17	14	1.5	1.5	45.0	45.8	6 700	9 000	TR0506R
	62	18.25	17	15	1.5	1.5	48.2	46.9	6 800	9 000	30305JR
	62	25.25	24	19	1.5	1.5	57.2	65.8	7 000	9 300	32305XR
	62	25.25	24	20	1.5	1.5	61.2	64.1	6 900	9 100	32305JR
28	52	16	16	12	1	1	35.2	44.0	7 500	10 000	320/28JR
	58	17.25	16	13	1	1	38.8	41.7	7 000	9 300	302/28CR
	58	17.25	16	14	1	1	38.8	42.0	7 000	9 300	302/28R
	58	20.25	19	16	1	1	44.9	54.1	7 100	9 400	322/28CR
	58	20.25	19	16	1	1	49.2	55.2	6 900	9 100	322/28R
	58	24	24	19	1	1	57.6	69.5	7 000	9 300	332/28JR
	68	19.75	18	14	1.5	1.5	51.7	50.2	6 200	8 200	303/28CR
	68	19.75	18	16	1.5	1.5	53.5	54.0	6 100	8 200	303/28R
	68	25.75	24	20	1.5	1.5	66.5	72.9	6 300	8 500	323/28CR
	68	25.75	24	21	1.5	1.5	69.6	75.6	6 100	8 100	323/28R
30	55	17	17	13	1	1	38.2	48.0	7 000	9 400	32006JR
	55	20	20	16	1	1	43.2	55.2	7 000	9 400	33006JR
	62	17.25	16	13	1	1	42.3	45.1	6 500	8 700	30206CR
	62	17.25	16	14	1	1	41.5	44.8	6 500	8 700	30206JR
	62	21.25	20	16	1	1	51.7	59.0	6 600	8 900	32206XR

[Note] 1) Please consult with JTEKT when using the bearings identified by suffix C. They are medium-tapered types especially designed for special purposes.

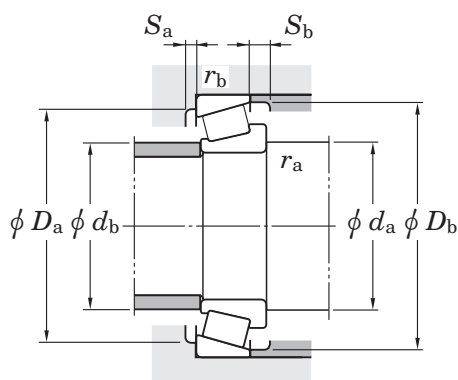

Dimension series to ISO355 (Refer.)	Load center (mm) a	Mounting dimensions (mm)										Con-stant e	Axial load factors		(Refer.) Mass (kg)
		d_a min.	d_b max.	D_a max.	D_b min.	S_a min.	S_b min.	r_a max.	r_b max.	Y_1	Y_0				
4CC	11.8	29.5	30	42.5	40	44	3	3.5	0.6	0.6	0.43	1.39	0.77	0.118	
2CE	10.9	29.5	30	42.5	41	44	3	3	0.6	0.6	0.29	2.07	1.14	0.131	
—	14.9	30.5	30	46.5	41	49	2	4	1	1	0.58	1.04	0.57	0.155	
3CC	12.9	30.5	31	46.5	44	48	2	3	1	1	0.37	1.60	0.88	0.156	
—	16.2	30.5	30	46.5	40	50	2	3	1	1	0.55	1.10	0.60	0.200	
2CD	13.5	30.5	31	46.5	43	48	2	4	1	1	0.36	1.67	0.92	0.188	
2DE	14.1	30.5	30	46.5	43	49	4	4	1	1	0.35	1.71	0.94	0.225	
7FB	20.4	33.5	34	53.5	47	58.5	3	5	1.5	1.5	0.83	0.73	0.40	0.269	
—	16.3	33.5	35	53.5	50	58	3	4	1.5	1.5	0.55	1.10	0.60	0.275	
2FB	12.9	33.5	34	54	54	57	2	3	1.5	1.5	0.30	2.00	1.10	0.273	
—	18.9	33.5	33	53.5	46	58	3	6	1.5	1.5	0.55	1.10	0.60	0.390	
2FD	16.6	33.5	33	53.5	52	57	3	5	1.5	1.5	0.30	2.00	1.10	0.386	
4CC	12.7	33.5	33	46.5	45	49	3	4	1	1	0.43	1.39	0.77	0.150	
—	16.0	33.5	34	52.5	47	55	2	4	1	1	0.55	1.10	0.60	0.205	
—	13.4	33.5	35	52.5	49	54	2	3	1	1	0.37	1.60	0.88	0.209	
—	17.0	33.5	33	52.5	45	55	3	4	1	1	0.55	1.10	0.60	0.255	
—	15.0	33.5	35	52.5	49	54.5	2	4	1	1	0.37	1.60	0.88	0.244	
2DE	15.4	33.5	34	52.5	49	55	4	5	1	1	0.34	1.77	0.97	0.302	
—	17.8	36.5	37	59.5	55	64	3	4.5	1.5	1.5	0.55	1.10	0.60	0.332	
—	14.9	36.5	38	59.5	58	63	2	3.5	1.5	1.5	0.32	1.88	1.04	0.345	
—	20.5	36.5	35	59.5	51	64	3	5.5	1.5	1.5	0.55	1.10	0.60	0.480	
—	17.6	36.5	38	59.5	57	63	3	4.5	1.5	1.5	0.32	1.88	1.04	0.469	
4CC	13.6	35.5	35	49.5	47	52	3	4	1	1	0.43	1.39	0.77	0.177	
2CE	13.0	35.5	36	49.5	48	52	3	4	1	1	0.29	2.06	1.13	0.203	
—	16.5	35.5	36	56.5	51	59	2	4	1	1	0.55	1.10	0.60	0.230	
3DB	14.1	35.5	37	56.5	53	57	2	3	1	1	0.37	1.60	0.88	0.236	
—	18.0	35.5	36	56.5	49	59	3	5	1	1	0.55	1.10	0.60	0.300	

Single-row tapered roller bearings metric series

d (30) ~ (35) mm

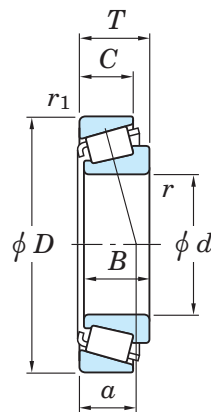

d	Boundary dimensions (mm)						Basic load ratings (kN)		Limiting speeds (min^{-1})		Bearing No. ¹⁾
	D	T	B	C	r min.	r_1 min.	C_r	C_{0r}	Grease lub.	Oil lub.	
30	62	21.25	20	17	1	1	50.7	57.9	6 500	8 700	32206JR
	62	25	25	19.5	1	1	66.4	79.4	6 500	8 700	33206JR
	72	20.75	19	14	1.5	1.5	50.9	54.9	4 900	6 800	30306DJR
	72	20.75	19	16	1.5	1.5	56.9	55.6	5 900	7 900	TRA0607R
	72	20.75	19	16	1.5	1.5	59.6	60.1	5 800	7 700	30306JR
	72	28.75	27	23	1.5	1.5	80.0	93.8	6 000	8 000	32306CR
	72	28.75	27	23	1.5	1.5	82.2	91.6	5 900	7 900	32306JR
32	58	17	17	13	1	1	39.2	50.6	6 700	8 900	320/32JR
	65	18.25	17	14	1	1	47.5	51.5	6 200	8 300	302/32CR
	65	18.25	17	15	1	1	48.0	51.4	6 200	8 200	302/32R
	65	22.25	21	17	1	1	55.8	65.1	6 300	8 400	322/32CR
	65	22.25	21	18	1	1	51.6	57.7	6 200	8 200	322/32
	65	26	26	20.5	1	1	71.8	86.9	6 200	8 300	332/32JR
	75	21.75	20	16	1.5	1.5	63.4	66.3	5 600	7 400	303/32CR
	75	21.75	20	18	1.5	1.5	64.4	65.6	5 500	7 300	303/32R
	75	29.75	28	23	1.5	1.5	75.1	87.1	5 600	7 400	TR0608A
75	29.75	28	25	1.5	1.5	89.6	101	5 600	7 400	323/32R	
35	55	14	14	11.5	0.6	0.6	26.1	36.5	6 600	8 800	32907JR-2
	62	18	18	14	1	1	45.5	59.4	6 200	8 200	32007JR
	62	21	20	16	1	1	40.8	53.8	6 200	8 200	33007
	62	21	21	17	1	1	51.3	68.0	6 200	8 200	33007JR
	72	18.25	17	15	1.5	1.5	52.9	56.2	5 700	7 600	30207CR
	72	18.25	17	15	1.5	1.5	55.1	60.9	5 600	7 400	30207JR
	72	24.25	23	19	1.5	1.5	69.0	86.6	5 700	7 600	32207-1R
	72	24.25	23	19	1.5	1.5	69.6	82.4	5 600	7 500	32207JR
	72	28	28	22	1.5	1.5	87.6	107	5 700	7 500	33207JR
	80	22.75	21	15	2	1.5	63.1	69.1	4 300	6 000	30307DJR

[Note] 1) Please consult with JTEKT when using the bearings identified by suffix C. They are medium-tapered types especially designed for special purposes.

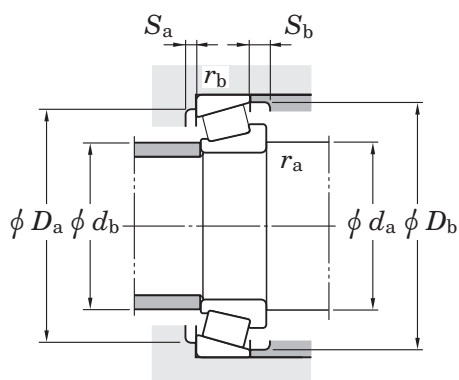

Dimension series to ISO355 (Refer.)	Load center (mm) a	Mounting dimensions (mm)										Con-stant e	Axial load factors		(Refer.) Mass (kg)
		d_a min.	d_b max.	D_a max.	D_b min.	S_a min.	S_b min.	r_a max.	r_b max.	Y_1	Y_0				
3DC	15.9	35.5	37	56.5	52	58	2	4	1	1	0.37	1.60	0.88	0.292	
2DE	16.3	35.5	36	56.5	53	59	5	5.5	1	1	0.34	1.76	0.97	0.359	
7FB	23.7	38.5	40	63.5	55	68	3	6.5	1.5	1.5	0.83	0.73	0.40	0.400	
—	18.6	38.5	39	63.5	58	68	3	4.5	1.5	1.5	0.55	1.10	0.60	0.405	
2FB	15.7	38.5	40	63.5	62	66	3	4.5	1.5	1.5	0.31	1.90	1.05	0.411	
5FD	22.0	38.5	37	63.5	54	68	3	5.5	1.5	1.5	0.55	1.10	0.60	0.610	
2FD	18.9	38.5	39	63.5	59	66	3	5.5	1.5	1.5	0.31	1.90	1.05	0.588	
4CC	14.3	37.5	38	52.5	50	55	3	4	1	1	0.45	1.32	0.73	0.196	
—	17.2	37.5	38	59.5	53	62	3	4	1	1	0.55	1.10	0.60	0.275	
—	14.9	37.5	39	59.5	55	61	3	3	1	1	0.37	1.60	0.88	0.266	
—	18.7	37.5	37	59.5	51	62	3	5	1	1	0.55	1.10	0.60	0.340	
—	16.3	37.5	40	59.5	55	61	2	4	1	1	0.37	1.60	0.88	0.330	
2DE	16.9	37.5	38	59.5	55	62	5	5.5	1	1	0.35	1.73	0.95	0.404	
—	19.7	40.5	42	66.5	60	70	3	5.5	1.5	1.5	0.55	1.10	0.60	0.465	
—	16.0	40.5	43	66.5	64	70	3	3.5	1.5	1.5	0.32	1.88	1.04	0.461	
5FD	23.7	40.5	41	66.5	57	71	3	6.5	1.5	1.5	0.55	1.10	0.60	0.649	
—	19.6	40.5	42	66.5	63	69	3	4.5	1.5	1.5	0.32	1.88	1.04	0.650	
2BD	10.9	39.5	40	50.5	49	52	2.5	2.5	0.6	0.6	0.29	2.06	1.13	0.120	
4CC	15.1	40.5	40	56.5	54	59	4	4	1	1	0.45	1.32	0.73	0.231	
—	14.8	40.5	41	56.5	55	59	3	4	1	1	0.33	1.80	0.99	0.250	
2CE	14.2	40.5	41	56.5	55	59	3	4	1	1	0.31	1.97	1.08	0.263	
—	17.9	43.5	43	63.5	59	68	3	3	1.5	1.5	0.55	1.10	0.60	0.350	
3DB	15.3	43.5	44	63.5	62	67	3	3	1.5	1.5	0.37	1.60	0.88	0.344	
—	21.1	43.5	42	63.5	56	68	3	5	1.5	1.5	0.58	1.04	0.57	0.465	
3DC	18.2	43.5	43	63.5	61	67	3	5	1.5	1.5	0.37	1.60	0.88	0.453	
2DE	18.4	43.5	42	63.5	61	68	5	6	1.5	1.5	0.35	1.70	0.93	0.551	
7FB	26.8	45	44	70	66	76.5	3	7.5	2	1.5	0.83	0.73	0.40	0.536	

Single-row tapered roller bearings metric series

d (35) ~ (45) mm

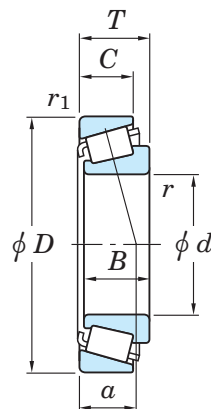

d	Boundary dimensions (mm)						Basic load ratings (kN)		Limiting speeds (min^{-1})		Bearing No. ¹⁾
	D	T	B	C	r min.	r_1 min.	C_r	C_{0r}	Grease lub.	Oil lub.	
35	80	22.75	21	18	2	1.5	69.8	77.8	5 200	7 000	30307XR
	80	22.75	21	18	2	1.5	76.2	78.9	5 200	6 900	30307JR-1
	80	32.75	31	25	2	1.5	96.9	123	5 200	7 000	TR0708-1R
	80	32.75	31	25	2	1.5	101	114	5 300	7 000	32307JR
40	62	15	15	12	0.6	0.6	33.5	48.5	5 900	7 800	32908JR
	68	19	19	14.5	1	1	53.5	71.4	5 600	7 400	32008JR
	68	22	22	18	1	1	60.4	84.6	5 500	7 400	33008JR
	75	26	26	20.5	1.5	1.5	82.2	108	5 200	6 900	33108JR
	80	19.75	18	15	1.5	1.5	61.4	67.4	5 000	6 700	30208CR
	80	19.75	18	16	1.5	1.5	62.9	69.2	5 000	6 700	30208JR
	80	24.75	23	19	1.5	1.5	78.5	93.1	5 000	6 700	32208CR
	80	24.75	23	19	1.5	1.5	77.7	90.8	5 000	6 600	32208JR
	80	32	32	25	1.5	1.5	108	139	5 000	6 700	33208JR
	85	33	32.5	28	2.5	2	114	143	4 800	6 400	T2EE040
	90	25.25	23	17	2	1.5	80.5	90.2	3 800	5 300	30308DJR
	90	25.25	23	20	2	1.5	87.3	98.5	4 600	6 100	30308XR
	90	25.25	23	20	2	1.5	90.6	101	4 500	6 100	30308JR
	90	35.25	33	26	2	1.5	112	138	4 700	6 200	TR0809AR
90	35.25	33	27	2	1.5	116	139	4 600	6 200	32308JR	
45	68	15	15	12	0.6	0.6	34.7	52.4	5 300	7 100	32909JR
	75	20	20	15.5	1	1	62.8	86.5	5 000	6 600	32009JR
	75	24	24	19	1	1	69.6	101	5 000	6 700	33009JR
	80	26	26	20.5	1.5	1.5	87.5	120	4 800	6 400	33109JR
	85	20.75	19	15	1.5	1.5	69.4	81.5	4 600	6 100	30209XR
	85	20.75	19	16	1.5	1.5	67.2	77.4	4 600	6 100	30209JR
	85	24.75	23	19	1.5	1.5	80.7	102	4 600	6 200	32209CR
	85	24.75	23	19	1.5	1.5	84.2	104	4 600	6 100	32209JR-1

[Note] 1) Please consult with JTEKT when using the bearings identified by suffix C. They are medium-tapered types especially designed for special purposes.

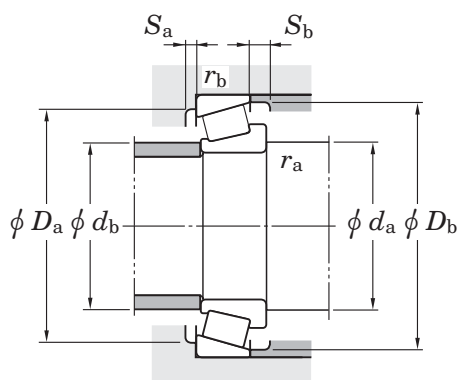

Dimension series to ISO355 (Refer.)	Load center (mm) a	Mounting dimensions (mm)										Constant e	Axial load factors		(Refer.) Mass (kg)
		d_a min.	d_b max.	D_a max.	D_b min.	S_a min.	S_b min.	r_a max.	r_b max.	Y_1	Y_0				
—	20.5	45	45	70	63	74	3	4.5	2	1.5	0.55	1.10	0.60	0.560	
2FB	16.9	45	45	70	70	74	3	4.5	2	1.5	0.31	1.90	1.05	0.527	
—	23.8	45	44	70	60	75	3	7.5	2	1.5	0.47	1.27	0.70	0.830	
2FE	20.6	45	44	70	66	74	3	7.5	2	1.5	0.31	1.90	1.05	0.776	
2BC	11.9	44.5	45	57.5	55	59	3	3	0.6	0.6	0.29	2.07	1.14	0.164	
3CD	15.1	45.5	46	62.5	60	65	4	4.5	1	1	0.38	1.58	0.87	0.282	
2BE	14.7	45.5	46	62.5	60	65	3	4	1	1	0.28	2.12	1.17	0.326	
2CE	18.3	48.5	47	66.5	65	71	4	5.5	1.5	1.5	0.36	1.69	0.93	0.508	
—	20.2	48.5	49	71.5	66	76	3	4.5	1.5	1.5	0.55	1.10	0.60	0.445	
3DB	17.0	48.5	49	71.5	69	75	3	3.5	1.5	1.5	0.37	1.60	0.88	0.434	
5DC	22.0	48.5	48	71.5	64	76	3	5.5	1.5	1.5	0.55	1.10	0.60	0.570	
3DC	19.4	48.5	48	71.5	68	75	3	5.5	1.5	1.5	0.37	1.60	0.88	0.554	
2DE	20.7	48.5	47	71.5	67	76	5	7	1.5	1.5	0.36	1.68	0.92	0.758	
2EE	21.9	52	48	75	70	80	5	5	2	2	0.34	1.74	0.96	0.900	
7FB	29.9	50	51	80	71	86.5	3	8	2	1.5	0.83	0.73	0.40	0.757	
—	23.8	50	53	80	72	84	3	5	2	1.5	0.55	1.10	0.60	0.780	
2FB	19.9	50	52	80	77	82	3	5	2	1.5	0.35	1.74	0.96	0.757	
—	27.5	50	49	80	67	85	3	9	2	1.5	0.55	1.10	0.60	1.10	
2FD	24.3	50	50	80	73	82	3	8	2	1.5	0.35	1.74	0.96	1.06	
2BC	12.5	49.5	50	63.5	61	64	3	3	0.6	0.6	0.32	1.88	1.04	0.190	
3CC	16.5	50.5	51	69.5	67	72	4	4.5	1	1	0.39	1.53	0.84	0.354	
2CE	16.4	50.5	51	69.5	67	71	4	5	1	1	0.29	2.04	1.12	0.416	
3CE	19.4	53.5	52	71.5	69	76.5	4	5.5	1.5	1.5	0.38	1.57	0.86	0.563	
—	21.1	53.5	54	76.5	71	80	4	5.5	1.5	1.5	0.55	1.10	0.60	0.500	
3DB	18.9	53.5	54	76.5	74	80	3	4.5	1.5	1.5	0.40	1.48	0.81	0.502	
—	23.0	53.5	53	76.5	69	81	3	5.5	1.5	1.5	0.55	1.10	0.60	0.625	
3DC	20.3	53.5	53	76.5	73	81	3	5.5	1.5	1.5	0.40	1.48	0.81	0.597	

Single-row tapered roller bearings metric series

d (45) ~ (55) mm

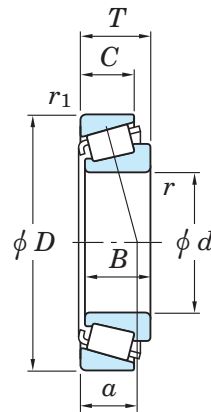

d	Boundary dimensions (mm)						Basic load ratings (kN)		Limiting speeds (min ⁻¹)		Bearing No. ¹⁾
	D	T	B	C	r min.	r_1 min.	C_r	C_{0r}	Grease lub.	Oil lub.	
45	85	32	32	25	1.5	1.5	112	149	4 600	6 200	33209JR
	95	29	26.5	20	2.5	2.5	94.1	118	3 600	5 100	T7FC045
	95	36	35	30	2.5	2.5	140	177	4 300	5 700	T2ED045
	100	27.25	25	18	2	1.5	95.1	107	3 400	4 700	30309DJR
	100	27.25	25	20	2	1.5	109	119	4 100	5 500	30309CR
	100	27.25	25	22	2	1.5	113	128	4 100	5 400	30309JR
	100	38.25	36	29	2	1.5	145	182	4 200	5 600	32309CR
	100	38.25	36	30	2	1.5	146	180	4 100	5 500	32309JR
50	72	15	15	12	0.6	0.6	35.9	56.3	4 900	6 600	32910JR
	80	20	20	15.5	1	1	65.7	94.5	4 600	6 100	32010JR
	80	24	24	19	1	1	73.0	110	4 600	6 100	33010JR
	85	26	26	20	1.5	1.5	89.4	127	4 400	5 900	33110JR
	90	21.75	20	16	1.5	1.5	77.2	95.8	4 300	5 700	30210CR
	90	21.75	20	17	1.5	1.5	76.5	91.7	4 300	5 700	30210JR
	90	24.75	23	19	1.5	1.5	84.5	113	4 300	5 700	32210CR
	90	24.75	23	19	1.5	1.5	85.0	105	4 300	5 700	32210JR
	90	32	32	24.5	1.5	1.5	119	167	4 300	5 700	33210JR
	100	36	35	30	2.5	2.5	157	196	4 100	5 400	T2ED050
	105	32	29	22	3	3	113	140	3 300	4 600	T7FC050
	110	29.25	27	19	2.5	2	115	133	3 100	4 300	30310DJR
	110	29.25	27	20	2.5	2	124	143	3 700	4 900	30310CR
	110	29.25	27	23	2.5	2	137	152	3 700	4 900	30310JR
	110	42.25	40	33	2.5	2	171	234	3 800	5 100	32310CR
	110	42.25	40	33	2.5	2	176	220	3 700	5 000	32310JR
55	80	17	17	14	1	1	44.6	73.3	4 400	5 900	32911JR
	90	23	23	17.5	1.5	1.5	84.6	121	4 100	5 500	32011JR
	90	27	27	21	1.5	1.5	96.5	149	4 100	5 400	33011JR

[Note] 1) Please consult with JTEKT when using the bearings identified by suffix C. They are medium-tapered types especially designed for special purposes.

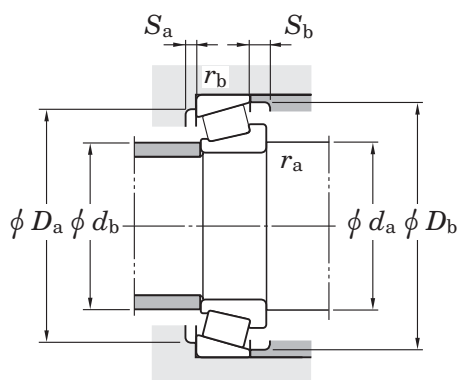

Dimension series to ISO355 (Refer.)	Load center (mm) a	Mounting dimensions (mm)										Constant e	Axial load factors		(Refer.) Mass (kg)
		d_a min.	d_b max.	D_a max.	D_b min.	S_a min.	S_b min.	r_a max.	r_b max.	Y_1	Y_0				
3DE	21.8	53.5	52	76.5	72	81	5	7	1.5	1.5	0.39	1.56	0.86	0.818	
7FC	32.6	57	54	83	71	91	3	9	2	2	0.87	0.69	0.38	0.943	
2ED	23.8	57	55	83	80	89	6	6	2	2	0.32	1.86	1.02	1.20	
7FB	32.9	55	56	90	79	96	3	9	2	1.5	0.83	0.73	0.40	0.973	
—	25.7	55	57	90	81	94	4	7	2	1.5	0.55	1.10	0.60	1.00	
2FB	21.3	55	59	90	86	93	3	5	2	1.5	0.35	1.74	0.96	1.01	
—	30.3	55	56	90	76	95	4	9	2	1.5	0.55	1.10	0.60	1.45	
2FD	26.8	55	56	90	82	93	3	8	2	1.5	0.35	1.74	0.96	1.43	
2BC	13.7	54.5	55	67.5	65	69	3	3	0.6	0.6	0.34	1.76	0.97	0.195	
3CC	17.7	55.5	56	74.5	72	77	4	4.5	1	1	0.42	1.42	0.78	0.389	
2CE	17.4	55.5	56	74.5	72	76	4	5	1	1	0.32	1.90	1.04	0.451	
3CE	20.6	58.5	56	76.5	74	81.5	4	6	1.5	1.5	0.41	1.46	0.80	0.594	
—	22.7	58.5	58	81.5	76	86	4	5.5	1.5	1.5	0.55	1.10	0.60	0.590	
3DB	20.1	58.5	58	81.5	79	85	3	4.5	1.5	1.5	0.42	1.43	0.79	0.566	
—	24.0	58.5	58	81.5	74	86	3	5.5	1.5	1.5	0.55	1.10	0.60	0.675	
3DC	20.6	58.5	58	81.5	78	85	3	5.5	1.5	1.5	0.42	1.43	0.79	0.643	
3DE	23.1	58.5	57	81.5	77	86.5	5	7.5	1.5	1.5	0.41	1.45	0.80	0.887	
2ED	24.5	62	58	88	84	94	6	6	2	2	0.34	1.75	0.96	1.28	
7FC	35.9	64	59	91	78	100	4	10	2.5	2.5	0.87	0.69	0.38	1.25	
7FB	35.0	62	62	98	87	105	3	10	2	2	0.83	0.73	0.40	1.25	
—	27.5	62	64	98	90	103	4	9	2	2	0.55	1.10	0.60	1.25	
2FB	22.9	62	65	98	95	102	3	6	2	2	0.35	1.74	0.96	1.32	
5FD	33.4	62	61	98	81	103	4	9	2	2	0.55	1.10	0.60	2.00	
2FD	29.4	62	62	98	90	102	3	9	2	2	0.35	1.74	0.96	1.89	
2BC	14.5	61	61	74	72	76	3	3	1	1	0.31	1.94	1.07	0.285	
3CC	19.8	63.5	63	81.5	81	86	4	5.5	1.5	1.5	0.41	1.48	0.81	0.569	
2CE	19.3	63.5	63	81.5	81	86	5	6	1.5	1.5	0.31	1.92	1.06	0.672	

Single-row tapered roller bearings metric series

d (55) ~ (60) mm

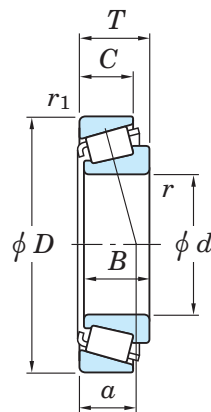

d	Boundary dimensions (mm)						Basic load ratings (kN)		Limiting speeds (min^{-1})		Bearing No. ¹⁾
	D	T	B	C	r min.	r_1 min.	C_r	C_{0r}	Grease lub.	Oil lub.	
55	95	30	30	23	1.5	1.5	116	161	4 000	5 300	33111JR
	100	22.75	21	17	2	1.5	89.6	108	3 900	5 200	30211CR
	100	22.75	21	18	2	1.5	94.6	113	3 900	5 200	30211JR
	100	26.75	25	21	2	1.5	107	135	3 900	5 200	32211CR
	100	26.75	25	21	2	1.5	107	133	3 900	5 200	32211JR-1
	100	35	35	27	2	1.5	142	189	3 900	5 200	33211JR
	115	34	31	23.5	3	3	129	164	3 000	4 200	T7FC055
	120	31.5	29	21	2.5	2	129	148	2 900	4 000	30311DJR
	120	31.5	29	22	2.5	2	144	161	3 400	4 500	30311CR
	120	31.5	29	25	2.5	2	149	170	3 300	4 500	30311JR
	120	45.5	43	35	2.5	2	184	247	3 400	4 600	32311C
	120	45.5	43	35	2.5	2	171	203	3 400	4 500	32311J
	120	45.5	43	35	2.5	2	200	250	3 400	4 500	32311JR
	60	85	17	17	14	1	1	46.2	78.2	4 100	5 500
95		23	23	17.5	1.5	1.5	86.1	127	3 900	5 200	32012JR
95		27	27	21	1.5	1.5	101	162	3 900	5 200	33012JR
100		30	30	23	1.5	1.5	118	170	3 700	5 000	33112JR
110		23.75	22	17	2	1.5	102	123	3 500	4 700	30212CR
110		23.75	22	19	2	1.5	106	127	3 500	4 700	30212JR
110		29.75	28	22	2	1.5	128	164	3 600	4 700	32212CR
110		29.75	28	24	2	1.5	132	167	3 500	4 700	32212JR
110		38	38	29	2	1.5	174	239	3 600	4 700	33212JR
115		39	38	31	4	2.5	158	227	3 400	4 600	T5ED060
115		40	39	33	2.5	2.5	183	242	3 400	4 600	T2EE060
125		37	33.5	26	3	3	153	194	2 800	3 900	T7FC060
130		33.5	31	22	3	2.5	153	179	2 600	3 700	30312DJR
130		33.5	31	23	3	2.5	169	196	3 100	4 200	30312CR

[Note] 1) Please consult with JTEKT when using the bearings identified by suffix C. They are medium-tapered types especially designed for special purposes.

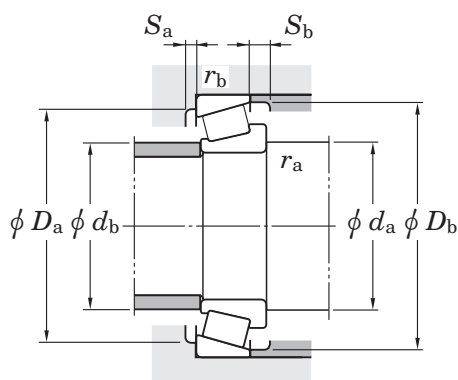

Dimension series to ISO355 (Refer.)	Load center (mm) a	Mounting dimensions (mm)										Con-stant e	Axial load factors		(Refer.) Mass (kg)
		d_a min.	d_b max.	D_a max.	D_b min.	S_a min.	S_b min.	r_a max.	r_b max.	Y_1	Y_0				
3CE	22.5	63.5	62	86.5	83	91	5	7	1.5	1.5	0.37	1.60	0.88	0.868	
—	24.3	65	63	90	84	95	4	5.5	2	1.5	0.55	1.10	0.60	0.750	
3DB	20.7	65	64	90	88	94	4	4.5	2	1.5	0.40	1.48	0.81	0.732	
—	25.9	65	64	90	83	96	4	5.5	2	1.5	0.55	1.10	0.60	0.875	
3DC	23.0	65	63	90	87	95	4	5.5	2	1.5	0.40	1.48	0.81	0.863	
3DE	25.3	65	62	90	85	96	6	8	2	1.5	0.40	1.50	0.83	1.18	
7FC	38.6	69	65	101	86	109	4	10.5	2.5	2.5	0.87	0.69	0.38	1.59	
7FB	38.4	67	68	108	94	113	4	10.5	2	2	0.83	0.73	0.40	1.59	
—	29.8	67	70	108	97	112	4.5	9.5	2	2	0.55	1.10	0.60	1.58	
2FB	25.5	67	71	108	104	111	4	6.5	2	2	0.35	1.74	0.96	1.65	
5FD	35.9	67	67	108	90	113	4	10	2	2	0.55	1.10	0.60	2.45	
2FD	32.4	67	68	108	99	111	4	10.5	2	2	0.35	1.74	0.96	2.24	
2FD	32.4	67	68	108	99	111	4	10.5	2	2	0.35	1.74	0.96	2.38	
2BC	15.6	65.5	66	79.5	77	81	3	3	1	1	0.33	1.81	1.00	0.306	
4CC	21.0	68.5	67	86.5	85	91	4	5.5	1.5	1.5	0.43	1.39	0.77	0.621	
2CE	20.1	68.5	67	86.5	85	90	5	6	1.5	1.5	0.33	1.83	1.01	0.719	
3CE	23.7	68.5	67	91.5	88	96	5	7	1.5	1.5	0.40	1.51	0.83	0.923	
—	26.2	70	70	100	93	104	4	6.5	2	1.5	0.55	1.10	0.60	0.930	
3EB	21.9	70	70	100	96	103	4	4.5	2	1.5	0.40	1.48	0.81	0.945	
—	28.6	70	68	100	91	105	4	7.5	2	1.5	0.55	1.10	0.60	1.20	
3EC	25.1	70	69	100	95	104	4	5.5	2	1.5	0.40	1.48	0.81	1.19	
3EE	27.2	70	69	100	93	105	6	9	2	1.5	0.40	1.48	0.82	1.57	
5ED	32.4	78	70	103	92	110	5	8	3	2	0.53	1.13	0.62	1.81	
2EE	27.6	72	70	103	98	109	6	7	2	2	0.33	1.80	0.99	1.80	
7FC	40.8	74	71	111	94	119	4	11	2.5	2.5	0.82	0.73	0.40	2.03	
7FB	40.8	74	73	118	103	124	4	11.5	2.5	2	0.83	0.73	0.40	2.01	
—	31.9	74	75	118	105	121	5	10.5	2.5	2	0.55	1.10	0.60	1.99	

Single-row tapered roller bearings metric series

d (60) ~ (70) mm

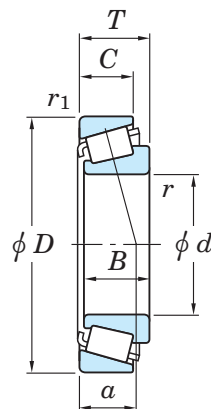

d	Boundary dimensions (mm)						Basic load ratings (kN)		Limiting speeds (min ⁻¹)		Bearing No. ¹⁾
	D	T	B	C	r min.	r_1 min.	C_r	C_{0r}	Grease lub.	Oil lub.	
60	130	33.5	31	26	3	2.5	173	201	3 100	4 100	30312JR
	130	48.5	46	37	3	2.5	229	310	3 200	4 300	32312CR
	130	48.5	46	37	3	2.5	221	275	3 100	4 200	32312J
	130	48.5	46	37	3	2.5	244	315	3 100	4 200	32312JR
65	90	17	17	14	1	1	47.4	83.1	3 900	5 200	32913JR
	100	23	23	17.5	1.5	1.5	90.0	137	3 600	4 800	32013JR
	100	27	27	21	1.5	1.5	103	169	3 600	4 800	33013JR
	110	34	34	26.5	1.5	1.5	152	223	3 400	4 600	33113JR
	120	24.75	23	18	2	1.5	116	139	3 200	4 300	30213CR
	120	24.75	23	20	2	1.5	128	156	3 200	4 300	30213JR
	120	32.75	31	24	2	1.5	151	198	3 200	4 300	32213CR
	120	32.75	31	27	2	1.5	157	203	3 200	4 300	32213JR
	120	39	38	31	4	2.5	151	232	3 200	4 300	T5ED065
	120	41	41	32	2	1.5	200	277	3 200	4 300	33213JR
	130	37	33.5	26	3	3	148	211	2 600	3 600	T7FC065
	140	36	33	23	3	2.5	176	209	2 400	3 400	30313DJR
	140	36	33	25	3	2.5	193	227	2 900	3 900	30313CR
	140	36	33	28	3	2.5	204	239	2 800	3 800	30313JR
	140	51	48	39	3	2.5	258	361	2 900	3 900	32313CR
	140	51	48	39	3	2.5	250	312	2 900	3 900	32313J
140	51	48	39	3	2.5	276	357	2 900	3 900	32313JR	
70	100	20	20	16	1	1	71.0	115	3 500	4 700	32914JR
	110	25	25	19	1.5	1.5	108	163	3 300	4 400	32014JR
	110	31	31	25.5	1.5	1.5	134	208	3 300	4 400	33014JR
	120	37	37	29	2	1.5	181	266	3 100	4 200	33114JR
	125	26.25	24	19	2	1.5	126	158	3 000	4 000	30214CR
	125	26.25	24	21	2	1.5	138	173	3 100	4 100	30214JR

[Note] 1) Please consult with JTEKT when using the bearings identified by suffix C. They are medium-tapered types especially designed for special purposes.

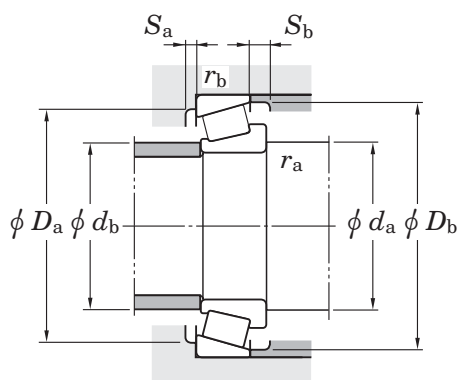

Dimension series to ISO355 (Refer.)	Load center (mm) a	Mounting dimensions (mm)										Constant e	Axial load factors		(Refer.) Mass (kg)
		d_a min.	d_b max.	D_a max.	D_b min.	S_a min.	S_b min.	r_a max.	r_b max.	Y_1	Y_0				
2FB	26.9	74	77	118	112	120	4	7.5	2.5	2	0.35	1.74	0.96	2.08	
5FD	38.3	74	73	118	98	122	5	11	2.5	2	0.55	1.10	0.60	3.15	
2FD	32.3	74	74	118	107	120	4	11.5	2.5	2	0.35	1.74	0.96	2.87	
2FD	32.3	74	74	118	107	120	4	11.5	2.5	2	0.35	1.74	0.96	2.99	
2BC	16.8	70.5	70	84.5	81	86	3	3	1	1	0.35	1.70	0.93	0.327	
4CC	22.5	73.5	72	91.5	90	97	4	5.5	1.5	1.5	0.46	1.31	0.72	0.664	
2CE	21.1	73.5	72	91.5	89	96	5	6	1.5	1.5	0.35	1.72	0.95	0.762	
3DE	25.9	73.5	73	101.5	96	106	6	7.5	1.5	1.5	0.39	1.55	0.85	1.33	
—	28.1	75	77	110	102	114	4	6.5	2	1.5	0.55	1.10	0.60	1.15	
3EB	24.2	75	77	110	106	113	4	4.5	2	1.5	0.40	1.48	0.81	1.18	
—	31.3	75	75	110	99	114	4	8.5	2	1.5	0.55	1.10	0.60	1.55	
3EC	26.6	75	76	110	104	115	4	5.5	2	1.5	0.40	1.48	0.81	1.58	
5ED	34.1	83	75	108	96	115	5	8	3	2	0.56	1.07	0.59	1.93	
3EE	30.0	75	74	110	102	115	7	9	2	1.5	0.39	1.54	0.85	2.02	
7FC	44.4	79	78	116	98	124	4	11	2.5	2.5	0.87	0.69	0.38	2.17	
7GB	44.3	79	79	128	111	133	4	13	2.5	2	0.83	0.73	0.40	2.44	
—	34.3	79	81	128	113	130	5	11	2.5	2	0.55	1.10	0.60	2.44	
2GB	29.3	79	83	128	122	130	4	8	2.5	2	0.35	1.74	0.96	2.56	
5GD	40.9	79	79	128	106	131	5	12	2.5	2	0.55	1.10	0.60	3.85	
2GD	34.7	79	80	128	117	130	4	12	2.5	2	0.35	1.74	0.96	3.49	
2GD	34.7	79	80	128	117	130	4	12	2.5	2	0.35	1.74	0.96	3.64	
2BC	17.8	75.5	77	94.5	91	96	4	4	1	1	0.32	1.90	1.05	0.496	
4CC	23.6	78.5	78	101.5	98	105	5	6	1.5	1.5	0.43	1.38	0.76	0.884	
2CE	22.1	78.5	78	101.5	99	105	5	5.5	1.5	1.5	0.28	2.11	1.16	1.09	
3DE	28.0	80	79	110	104	115	6	8	2	1.5	0.38	1.58	0.87	1.71	
—	29.9	80	82	116.5	107	119	4	7	2	1.5	0.55	1.10	0.60	1.30	
3EB	25.9	80	81	116.5	110	118	4	5	2	1.5	0.42	1.43	0.79	1.32	

Single-row tapered roller bearings metric series

d (70) ~ (75) mm

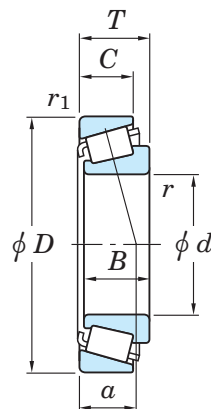

d	Boundary dimensions (mm)						Basic load ratings (kN)		Limiting speeds (min ⁻¹)		Bearing No. ¹⁾
	D	T	B	C	r min.	r_1 min.	C_r	C_{0r}	Grease lub.	Oil lub.	
70	125	33.25	31	24	2	1.5	157	212	3 100	4 100	32214CR
	125	33.25	31	27	2	1.5	169	225	3 100	4 100	32214JR
	125	41	41	32	2	1.5	206	294	3 100	4 100	33214JR
	130	43	42	35	3	2.5	233	319	3 000	4 000	T2ED070
	140	39	35.5	27	3	3	177	242	2 400	3 400	T7FC070
	140	52	51	43	5	3	264	382	2 900	3 800	T4FE070
	150	38	35	25	3	2.5	197	235	2 300	3 200	30314DJR
	150	38	35	30	3	2.5	224	256	2 700	3 600	30314CR
	150	38	35	30	3	2.5	230	273	2 600	3 500	30314JR
	150	54	51	42	3	2.5	257	315	2 700	3 600	32314
	150	54	51	42	3	2.5	297	391	2 700	3 600	32314C
	150	54	51	42	3	2.5	317	414	2 700	3 600	32314JR
75	105	20	20	16	1	1	73.6	123	3 300	4 400	32915JR
	115	25	25	19	1.5	1.5	110	169	3 100	4 200	32015JR
	115	31	31	25.5	1.5	1.5	141	225	3 200	4 200	33015JR
	125	37	37	29	2	1.5	186	280	3 000	4 000	33115JR
	130	27.25	25	20	2	1.5	136	178	2 900	3 800	30215CR
	130	27.25	25	22	2	1.5	142	181	2 900	3 900	30215JR
	130	33.25	31	24	2	1.5	163	225	2 900	3 900	32215CR
	130	33.25	31	27	2	1.5	174	234	2 900	3 900	32215JR
	130	41	41	31	2	1.5	212	310	2 900	3 900	33215JR
	150	42	38	29	3	3	191	270	2 200	3 100	T7FC075
	160	40	37	26	3	2.5	213	254	2 100	2 900	30315DJR
	160	40	37	26	3	2.5	222	266	2 100	2 900	30315DR
	160	40	37	31	3	2.5	248	296	2 500	3 400	30315CR
	160	40	37	31	3	2.5	260	311	2 500	3 300	30315JR
	160	40	37	31	3	2.5	251	298	2 500	3 300	30315R

[Note] 1) Please consult with JTEKT when using the bearings identified by suffix C. They are medium-tapered types especially designed for special purposes.

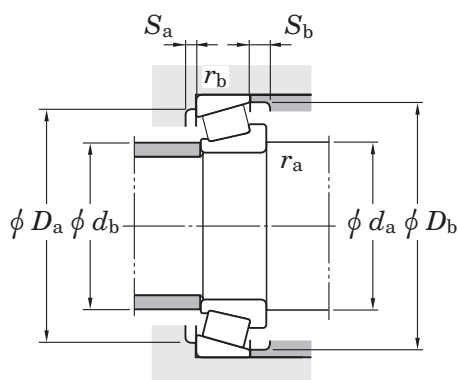

Dimension series to ISO355 (Refer.)	Load center (mm) a	Mounting dimensions (mm)										Con-stant e	Axial load factors		(Refer.) Mass (kg)
		d_a min.	d_b max.	D_a max.	D_b min.	S_a min.	S_b min.	r_a max.	r_b max.	Y_1	Y_0				
—	32.6	80	80	116.5	104	120	4	9.5	2	1.5	0.55	1.10	0.60	1.65	
3EC	29.2	80	80	116.5	108	119	4	6	2	1.5	0.42	1.43	0.79	1.71	
3EE	31.2	80	79	116.5	107	120	7	9	2	1.5	0.41	1.47	0.81	2.16	
2ED	30.2	84	81	118	111	123	1	1	2.5	2	0.33	1.80	0.99	2.48	
7FC	46.5	84	82	126	106	133	5	12	2.5	2.5	0.87	0.69	0.38	2.64	
4FE	37.7	92	82	126	111	133	7	9	4	2.5	0.45	1.34	0.74	3.69	
7GB	47.1	84	84	138	118	142	4	13	2.5	2	0.83	0.73	0.40	2.97	
—	37.0	84	87	138	123	141	6	8	2.5	2	0.55	1.10	0.60	3.10	
2GB	30.5	84	89	138	130	140	4	8	2.5	2	0.35	1.74	0.96	3.08	
—	37.0	84	86	138	125	140	4	12	2.5	2	0.35	1.73	0.95	4.11	
5GD	44.4	84	84	138	115	142	5	12	2.5	2	0.55	1.10	0.60	4.50	
2GD	37.4	84	86	138	125	140	4	12	2.5	2	0.35	1.74	0.96	4.50	
2BC	18.9	80.5	81	99.5	96	101	4	4	1	1	0.33	1.80	0.99	0.526	
4CC	25.1	83.5	83	106.5	103	110	5	6	1.5	1.5	0.46	1.31	0.72	0.930	
2CE	22.9	83.5	83	106.5	104	110	6	5.5	1.5	1.5	0.30	2.01	1.11	1.16	
3DE	29.3	85	84	116.5	109	120	6	8	2	1.5	0.40	1.51	0.83	1.84	
—	31.0	85	87	121.5	111	124	5	7	2	1.5	0.55	1.10	0.60	1.40	
4DB	27.6	85	86	121.5	115	124	4	5	2	1.5	0.44	1.38	0.76	1.42	
—	33.7	85	85	121.5	109	125	4	9	2	1.5	0.55	1.10	0.60	1.75	
4DC	30.2	85	85	121.5	114	125	4	6	2	1.5	0.44	1.38	0.76	1.77	
3EE	32.5	85	83	121.5	111	125	7	10	2	1.5	0.43	1.40	0.77	2.26	
7FC	50.6	89	89	136	114	143	5	13	2.5	2.5	0.87	0.69	0.38	3.24	
7GB	49.9	89	91	148	127	151	6	14	2.5	2	0.83	0.73	0.40	3.45	
—	48.8	89	91	148	127	151	6	14	2.5	2	0.81	0.74	0.41	3.48	
—	39.2	89	94	148	130	150	6	9	2.5	2	0.55	1.10	0.60	3.80	
2GB	32.5	89	95	148	139	149	4	9	2.5	2	0.35	1.74	0.96	3.65	
—	31.9	89	95	148	139	149	4	9	2.5	2	0.35	1.73	0.95	3.52	

Single-row tapered roller bearings metric series

d (75) ~ (85) mm

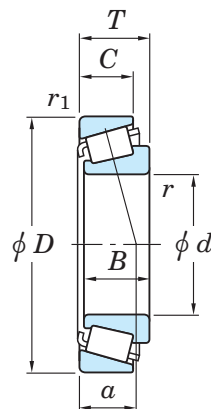

d	Boundary dimensions (mm)						Basic load ratings (kN)		Limiting speeds (min ⁻¹)		Bearing No. ¹⁾
	D	T	B	C	r min.	r_1 min.	C_r	C_{0r}	Grease lub.	Oil lub.	
75	160	58	55	43	3	2.5	357	474	2 500	3 400	32315CR
	160	58	55	45	3	2.5	363	481	2 500	3 300	32315JR
	160	58	55	45	3	2.5	340	444	2 500	3 300	32315R
80	110	20	20	16	1	1	76.1	131	3 100	4 200	32916JR
	125	29	29	22	1.5	1.5	147	225	2 900	3 900	32016JR
	125	36	36	29.5	1.5	1.5	173	288	2 900	3 900	33016JR
	130	37	37	29	2	1.5	191	294	2 800	3 800	33116JR
	140	28.25	26	22	2.5	2	161	202	2 700	3 600	30216JR
	140	35.25	33	28	2.5	2	203	271	2 700	3 600	32216JR
	140	46	46	35	2.5	2	250	371	2 700	3 600	33216JR
	145	46	45	38	3	2.5	266	381	2 600	3 500	T2ED080
	170	42.5	39	27	3	2.5	236	282	2 000	2 800	30316DJR
	170	42.5	39	33	3	2.5	294	355	2 300	3 100	30316JR
	170	42.5	39	33	3	2.5	277	330	2 300	3 100	30316R
	170	61.5	58	48	3	2.5	347	440	2 300	3 100	32316J
	170	61.5	58	48	3	2.5	383	503	2 300	3 100	32316JR
85	120	23	23	18	1.5	1.5	97.1	165	2 900	3 900	32917JR
	130	29	29	22	1.5	1.5	150	234	2 800	3 700	32017JR
	130	36	36	29.5	1.5	1.5	177	300	2 800	3 700	33017JR
	140	41	41	32	2.5	2	224	346	2 600	3 500	33117JR
	150	30.5	28	24	2.5	2	182	231	2 500	3 400	30217JR
	150	38.5	36	30	2.5	2	232	315	2 500	3 400	32217JR
	150	49	49	37	2.5	2	294	439	2 500	3 400	33217JR
	180	44.5	41	28	4	3	231	265	1 900	2 600	30317D
	180	44.5	41	28	4	3	263	317	1 900	2 600	30317DJR
	180	44.5	41	34	4	3	316	384	2 200	2 900	30317JR
	180	44.5	41	34	4	3	305	367	2 200	2 900	30317R

[Note] 1) Please consult with JTEKT when using the bearings identified by suffix C. They are medium-tapered types especially designed for special purposes.

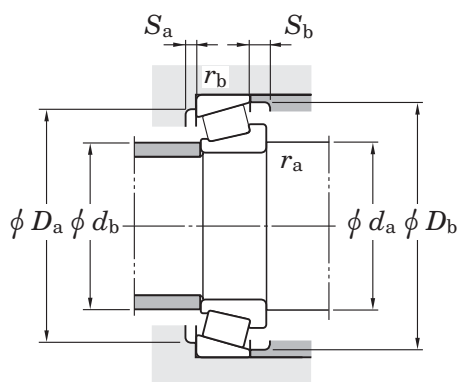

Dimension series to ISO355 (Refer.)	Load center (mm) a	Mounting dimensions (mm)										Con-stant e	Axial load factors		(Refer.) Mass (kg)
		d_a min.	d_b max.	D_a max.	D_b min.	S_a min.	S_b min.	r_a max.	r_b max.	Y_1	Y_0				
—	46.6	89	90	148	125	154	6	15	2.5	2	0.55	1.10	0.60	5.50	
2GD	40.0	89	91	148	133	149	4	13	2.5	2	0.35	1.74	0.96	5.41	
—	39.5	89	91	148	133	149	4	13	2.5	2	0.35	1.73	0.95	5.30	
2BC	20.1	85.5	86	104.5	101	106	4	4	1	1	0.35	1.71	0.94	0.556	
3CC	26.7	88.5	89	116.5	112	120	6	7	1.5	1.5	0.42	1.42	0.78	1.32	
2CE	25.1	88.5	90	116.5	112	119	6	6.5	1.5	1.5	0.28	2.16	1.19	1.63	
3DE	30.5	90	89	121.5	114	126	6	8	2	1.5	0.42	1.44	0.79	1.93	
3EB	28.6	92	91	130	124	132	4	6	2	2	0.42	1.43	0.79	1.72	
3EC	31.7	92	90	130	122	134	4	7	2	2	0.42	1.43	0.79	2.17	
3EE	35.7	92	89	130	119	135	7	11	2	2	0.43	1.41	0.78	2.99	
2ED	32.7	94	92	133	125	137	7	8	2.5	2	0.32	1.88	1.03	3.20	
7GB	53.5	94	97	158	134	159	6	15.5	2.5	2	0.83	0.73	0.40	4.12	
2GB	34.8	94	102	158	148	159	4	9.5	2.5	2	0.35	1.74	0.96	4.46	
—	33.9	94	102	158	148	159	4	9.5	2.5	2	0.35	1.73	0.95	4.26	
2GD	43.5	94	98	158	142	159	4	13.5	2.5	2	0.35	1.74	0.96	6.04	
2GD	43.5	94	98	158	142	159	4	13.5	2.5	2	0.35	1.74	0.96	6.31	
2BC	21.2	93.5	93	111.5	109	115	5	5	1.5	1.5	0.33	1.83	1.01	0.794	
4CC	28.0	93.5	94	121.5	117	125	6	7	1.5	1.5	0.44	1.36	0.75	1.38	
2CE	26.3	93.5	94	121.5	118	125	6	6.5	1.5	1.5	0.29	2.06	1.13	1.72	
3DE	33.2	97	95	130	122	135	7	9	2	2	0.41	1.48	0.81	2.43	
3EB	30.4	97	97	140	132	141	5	6.5	2	2	0.42	1.43	0.79	2.17	
3EC	34.2	97	96	140	130	142	5	8.5	2	2	0.42	1.43	0.79	2.80	
3EE	37.1	97	95	140	128	144	7	12	2	2	0.42	1.43	0.79	3.63	
—	56.0	103	103	166	143	169	6	16.5	3	2.5	0.81	0.74	0.41	4.54	
7GB	56.3	103	103	166	143	169	6	16.5	3	2.5	0.83	0.73	0.40	4.81	
2GB	36.0	103	107	166	156	167	5	10.5	3	2.5	0.35	1.74	0.96	5.15	
—	35.8	103	107	166	156	167	5	10.5	3	2.5	0.35	1.73	0.95	4.97	

Single-row tapered roller bearings metric series

d (85) ~ 95 mm

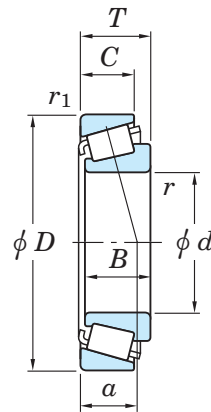

d	Boundary dimensions (mm)						Basic load ratings (kN)		Limiting speeds (min ⁻¹)		Bearing No.
	D	T	B	C	r min.	r_1 min.	C_r	C_{0r}	Grease lub.	Oil lub.	
85	180	63.5	60	49	4	3	439	587	2 200	3 000	32317JR
90	125	23	23	18	1.5	1.5	101	175	2 800	3 700	32918JR
	140	32	32	24	2	1.5	178	276	2 600	3 500	32018JR
	140	39	39	32.5	2	1.5	221	367	2 600	3 400	33018JR
	150	45	45	35	2.5	2	258	413	2 500	3 300	33118JR
	155	46	46	38	3	3	273	405	2 400	3 200	T2ED090
	160	32.5	30	26	2.5	2	204	261	2 400	3 200	30218JR
	160	42.5	40	34	2.5	2	263	362	2 400	3 200	32218JR
	160	55	55	42	2.5	2	343	527	2 400	3 200	33218JR
	190	46.5	43	30	4	3	288	350	1 700	2 400	30318DJR
	190	46.5	43	30	4	3	282	336	1 700	2 400	30318DR
	190	46.5	43	36	4	3	345	420	2 100	2 700	30318JR
	190	46.5	43	36	4	3	336	407	2 100	2 700	30318R
	190	67.5	64	53	4	3	461	614	2 100	2 800	32318JR
95	130	23	23	18	1.5	1.5	104	186	2 600	3 500	32919JR
	145	32	32	24	2	1.5	182	287	2 500	3 300	32019JR
	145	39	39	32.5	2	1.5	226	382	2 500	3 300	33019JR
	160	46	46	38	3	3	281	427	2 300	3 100	T2ED095
	160	49	49	38	2.5	2	304	473	2 300	3 100	33119JR
	170	34.5	32	27	3	2.5	231	299	2 200	3 000	30219JR
	170	45.5	43	37	3	2.5	311	439	2 200	3 000	32219JR
	170	58	58	44	3	2.5	374	582	2 200	2 900	33219JR
	200	49.5	45	32	4	3	319	391	1 700	2 300	30319DJR
	200	49.5	45	38	4	3	317	368	2 000	2 600	30319
	200	49.5	45	38	4	3	372	455	2 000	2 600	30319JR
	200	71.5	67	55	4	3	427	544	2 000	2 600	32319
	200	71.5	67	55	4	3	517	695	2 000	2 600	32319JR

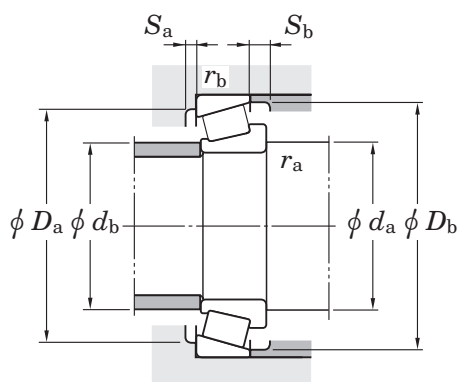

Dimension series to ISO355 (Refer.)	Load center (mm) <i>a</i>	Mounting dimensions (mm)										Con-stant <i>e</i>	Axial load factors		(Refer.) Mass (kg)
		<i>d_a</i> min.	<i>d_b</i> max.	<i>D_a</i> max.	<i>D_b</i> min.	<i>S_a</i> min.	<i>S_b</i> min.	<i>r_a</i> max.	<i>r_b</i> max.	<i>Y₁</i>	<i>Y₀</i>				
2GD	43.8	103	103	166	150	167	5	14.5	3	2.5	0.35	1.74	0.96	7.42	
2BC	22.3	98.5	97	116.5	114	120	5	5	1.5	1.5	0.34	1.75	0.96	0.834	
3CC	29.8	100	100	131.5	125	134	6	8	2	1.5	0.42	1.42	0.78	1.80	
2CE	27.1	100	100	131.5	127	135	7	6.5	2	1.5	0.27	2.23	1.23	2.22	
3DE	35.4	102	100	140	130	144	7	10	2	2	0.40	1.51	0.83	3.13	
2ED	33.5	104	102	141	135	147	7	8	2.5	2.5	0.33	1.84	1.01	3.47	
3FB	32.6	102	103	150	140	150	5	6.5	2	2	0.42	1.43	0.79	2.65	
3FC	37.0	102	102	150	138	152	5	8.5	2	2	0.42	1.43	0.79	3.47	
3FE	40.8	102	101	150	135	154	9	13	2	2	0.42	1.43	0.78	4.76	
7GB	59.6	108	109	176	151	179	6	16.5	3	2.5	0.83	0.73	0.40	5.57	
—	59.1	108	109	176	151	179	6	16.5	3	2.5	0.81	0.74	0.41	5.60	
2GB	38.1	108	113	176	165	177	5	10.5	3	2.5	0.35	1.74	0.96	6.04	
—	37.2	108	113	176	165	177	5	10.5	3	2.5	0.35	1.73	0.95	5.78	
2GD	46.6	108	108	176	157	177	5	14.5	3	2.5	0.35	1.74	0.96	8.61	
2BC	23.5	103.5	102	121.5	119	125	5	5	1.5	1.5	0.36	1.68	0.92	0.876	
4CC	31.2	105	105	136.5	130	140	6	8	2	1.5	0.44	1.36	0.75	1.88	
2CE	27.8	105	104	136.5	131	139	7	6.5	2	1.5	0.28	2.16	1.19	2.31	
2ED	34.6	109	107	146	140	152	7	8	2.5	2.5	0.34	1.77	0.97	3.62	
3EE	37.3	107	106	150	138	154	8	11	2	2	0.39	1.54	0.85	3.89	
3FB	34.9	109	110	158	149	159	5	7.5	2.5	2	0.42	1.43	0.79	3.20	
3FC	38.9	109	108	158	145	161	5	8.5	2.5	2	0.42	1.43	0.79	4.34	
3FE	42.8	109	107	158	144	163	9	14	2.5	2	0.41	1.47	0.81	5.66	
7GB	62.7	113	113	186	157	187	6	17.5	3	2.5	0.83	0.73	0.40	6.68	
—	39.8	113	118	186	172	186	5	11.5	3	2.5	0.35	1.73	0.95	6.32	
2GB	40.8	113	118	186	172	186	5	11.5	3	2.5	0.35	1.74	0.96	6.96	
—	49.1	113	115	186	166	186	5	16.5	3	2.5	0.35	1.73	0.95	9.35	
2GD	49.8	113	115	186	166	186	5	16.5	3	2.5	0.35	1.74	0.96	10.1	

Single-row tapered roller bearings metric series

d 100 ~ (105) mm

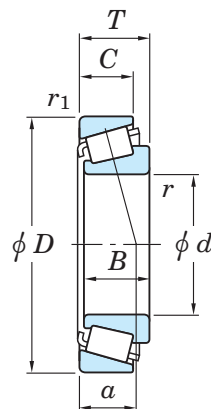

d	Boundary dimensions (mm)						Basic load ratings (kN)		Limiting speeds (min ⁻¹)		Bearing No.
	D	T	B	C	r min.	r_1 min.	C_r	C_{0r}	Grease lub.	Oil lub.	
100	140	25	25	20	1.5	1.5	126	217	2 400	3 300	32920JR
	145	24	22.5	17.5	3	3	116	167	2 400	3 200	T4CB100
	150	32	32	24	2	1.5	185	298	2 400	3 200	32020JR
	150	39	39	32.5	2	1.5	231	397	2 400	3 200	33020JR
	165	47	46	39	3	3	293	458	2 200	3 000	T2EE100
	165	52	52	40	2.5	2	325	523	2 200	3 000	33120JR
	180	37	34	29	3	2.5	258	338	2 100	2 800	30220JR
	180	49	46	39	3	2.5	347	495	2 100	2 800	32220JR
	180	63	63	48	3	2.5	431	680	2 100	2 800	33220JR
	215	51.5	47	34	4	3	318	374	1 500	2 100	30320D
	215	51.5	47	39	4	3	344	400	1 800	2 400	30320
	215	51.5	47	39	4	3	422	521	1 800	2 400	30320JR
	215	56.5	51	35	4	3	373	459	1 500	2 200	31320JR
	215	77.5	73	60	4	3	491	637	1 800	2 400	32320
	215	77.5	73	60	4	3	579	783	1 800	2 400	32320JR
105	145	25	25	20	1.5	1.5	128	224	2 400	3 100	32921JR
	160	35	35	26	2.5	2	215	344	2 200	3 000	32021JR
	160	43	43	34	2.5	2	267	461	2 200	3 000	33021JR
	175	56	56	44	2.5	2	360	607	2 100	2 800	33121JR
	190	39	36	30	3	2.5	288	380	2 000	2 600	30221JR
	190	53	50	43	3	2.5	392	567	2 000	2 700	32221JR
	190	68	68	52	3	2.5	497	790	2 000	2 600	33221JR
	225	53.5	49	36	4	3	339	396	1 400	2 000	30321D
	225	53.5	49	41	4	3	371	432	1 700	2 300	30321
	225	53.5	49	41	4	3	464	578	1 700	2 300	30321JR
	225	58	53	36	4	3	397	489	1 500	2 100	31321JR
	225	81.5	77	63	4	3	543	707	1 800	2 300	32321

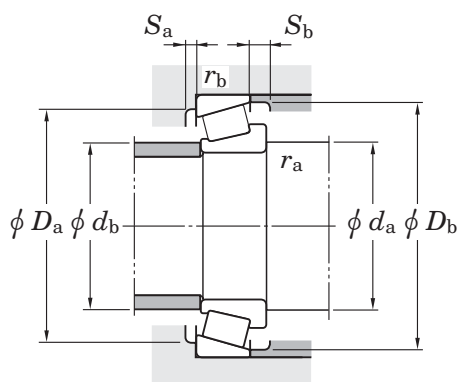

Dimension series to ISO355 (Refer.)	Load center (mm) a	Mounting dimensions (mm)										Con-stant e	Axial load factors		(Refer.) Mass (kg)
		d_a min.	d_b max.	D_a max.	D_b min.	S_a min.	S_b min.	r_a max.	r_b max.	Y_1	Y_0				
2CC	24.0	109	108	131	128	135	5	5	1.5	1.5	0.33	1.82	1.00	1.19	
4CB	29.9	112	109	133	132	140	4	6.5	2.5	2.5	0.47	1.27	0.70	1.12	
4CC	32.6	110	109	141	134	144	6	8	2	1.5	0.46	1.31	0.72	1.95	
2CE	28.6	110	108	141	135	143	7	6.5	2	1.5	0.29	2.09	1.15	2.40	
2EE	35.1	114	112	151	145	157	7	8	2.5	2.5	0.32	1.88	1.04	3.86	
3EE	40.1	112	111	155	142	159	8	12	2	2	0.41	1.48	0.81	4.29	
3FB	36.8	114	116	168	157	168	5	8	2.5	2	0.42	1.43	0.79	3.83	
3FC	42.1	114	114	168	154	171	5	10	2.5	2	0.42	1.43	0.79	5.21	
3FE	45.7	114	112	168	151	172	10	15	2.5	2	0.40	1.48	0.82	6.92	
—	65.9	118	121	201	183	204	5	17	3	2.5	0.81	0.74	0.41	8.02	
—	41.4	118	127	201	184	200	6	12.5	3	2.5	0.35	1.73	0.95	7.76	
2GB	42.7	118	127	201	184	200	6	12.5	3	2.5	0.35	1.74	0.96	8.49	
7GB	67.7	118	120	201	183	202	6	17.5	3	2.5	0.83	0.73	0.40	8.72	
—	52.6	118	123	201	177	200	8	17.5	3	2.5	0.35	1.73	0.95	12.2	
2GD	53.9	118	123	201	177	200	8	17.5	3	2.5	0.35	1.74	0.96	13.0	
2CC	25.1	113.5	113	136.5	133	140	5	5	1.5	1.5	0.34	1.75	0.96	1.23	
4DC	34.5	117	116	150	143	154	6	9	2	2	0.44	1.35	0.74	2.45	
2DE	30.9	117	116	150	145	153	7	9	2	2	0.28	2.12	1.17	3.08	
3EE	43.2	117	116	165	150	169	9	12	2	2	0.40	1.48	0.82	5.33	
3FB	39.0	119	122	178	165	178	6	9	2.5	2	0.42	1.43	0.79	4.49	
3FC	44.8	119	120	178	161	180	6	10	2.5	2	0.42	1.43	0.79	6.37	
3FE	48.8	119	117	178	159	182	10	16	2.5	2	0.40	1.49	0.82	8.43	
—	69.1	123	127	211	193	209	6	17	3	2.5	0.81	0.74	0.41	8.76	
—	43.1	123	132	211	193	209	7	12.5	3	2.5	0.35	1.73	0.95	8.74	
2GB	44.1	123	132	211	193	209	7	12.5	3	2.5	0.35	1.74	0.96	9.73	
7GB	70.3	123	126	211	193	211	6	18	3	2.5	0.83	0.73	0.40	9.72	
—	55.7	123	128	211	185	209	8	18.5	3	2.5	0.35	1.73	0.95	13.9	

Single-row tapered roller bearings metric series

d (105) ~ 120 mm

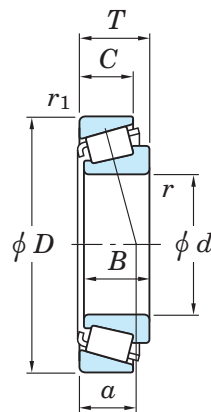

d	Boundary dimensions (mm)						Basic load ratings (kN)		Limiting speeds (min ⁻¹)		Bearing No.
	D	T	B	C	r min.	r_1 min.	C_r	C_{0r}	Grease lub.	Oil lub.	
105	225	81.5	77	63	4	3	635	866	1 800	2 300	32321JR
110	150	25	25	20	1.5	1.5	129	231	2 300	3 000	32922JR
	160	27	25.5	19.5	3	3	146	225	2 200	2 900	T4CB110
	170	38	38	29	2.5	2	248	395	2 100	2 800	32022JR
	170	47	47	37	2.5	2	287	502	2 100	2 800	33022JR
	180	56	56	43	2.5	2	369	634	2 000	2 700	33122JR
	200	41	38	32	3	2.5	324	434	1 900	2 500	30222JR
	200	56	53	46	3	2.5	438	640	1 900	2 500	32222JR
	240	54.5	50	36	4	3	365	429	1 400	1 900	30322D
	240	54.5	50	42	4	3	407	475	1 600	2 100	30322
	240	54.5	50	42	4	3	481	590	1 600	2 100	30322JR
	240	63	57	38	4	3	452	563	1 400	1 900	31322JR
	240	84.5	80	65	4	3	607	797	1 600	2 200	32322
	240	84.5	80	65	4	3	691	943	1 600	2 200	32322JR
120	165	29	29	23	1.5	1.5	172	298	2 100	2 700	32924JR
	170	27	25	19.5	3	3	164	262	2 000	2 700	T4CB120
	180	38	38	29	2.5	2	258	427	2 000	2 600	32024JR
	180	48	48	38	2.5	2	299	540	2 000	2 600	33024JR
	200	62	62	48	2.5	2	462	785	1 800	2 400	33124JR
	215	43.5	40	34	3	2.5	347	473	1 700	2 300	30224JR
	215	61.5	58	50	3	2.5	470	691	1 700	2 300	32224JR
	260	59.5	55	38	4	3	430	512	1 200	1 700	30324D
	260	59.5	55	46	4	3	505	611	1 500	2 000	30324
	260	59.5	55	46	4	3	569	714	1 500	2 000	30324JR
	260	68	62	42	4	3	526	665	1 300	1 800	31324JR
	260	90.5	86	69	4	3	800	1 110	1 500	2 000	32324JR
	260	90.5	86	69	4	3	797	1 110	1 500	2 000	32324R

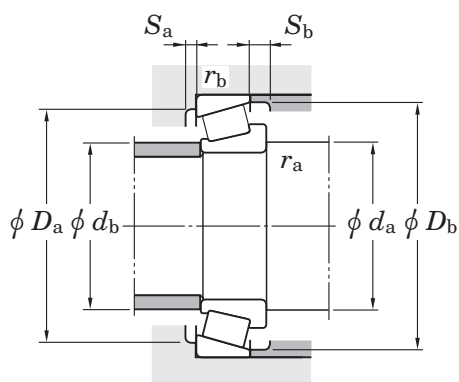

Dimension series to ISO355 (Refer.)	Load center (mm) a	Mounting dimensions (mm)										Constant e	Axial load factors		(Refer.) Mass (kg)
		d_a min.	d_b max.	D_a max.	D_b min.	S_a min.	S_b min.	r_a max.	r_b max.	Y_1	Y_0				
2GD	56.1	123	128	211	185	209	8	18.5	3	2.5	0.35	1.74	0.96	14.9	
2CC	26.3	119	118	141	138	145	5	5	1.5	1.5	0.36	1.69	0.93	1.28	
4CB	31.8	124	120	146	145	154	5	7.5	2.5	2.5	0.44	1.36	0.75	1.63	
4DC	36.1	122	122	160	152	163	7	9	2	2	0.43	1.39	0.77	3.12	
2DE	33.4	122	123	160	152	161	7	10	2	2	0.29	2.09	1.15	3.81	
3EE	44.5	122	121	170	155	174	9	13	2	2	0.42	1.43	0.79	5.52	
3FB	40.8	124	129	188	174	188	6	9	2.5	2	0.42	1.43	0.79	5.33	
3FC	46.7	124	126	188	170	190	6	10	2.5	2	0.42	1.43	0.79	7.45	
—	71.5	128	135	226	205	222	6	18	3	2.5	0.81	0.74	0.41	10.2	
—	44.8	128	141	226	206	222	8	12.5	3	2.5	0.35	1.73	0.95	10.4	
2GB	46.3	128	141	226	206	222	8	12.5	3	2.5	0.35	1.74	0.96	11.4	
7GB	76.2	128	135	226	205	224	6	21	3	2.5	0.83	0.73	0.40	12.2	
—	57.3	128	137	226	198	222	9	19.5	3	2.5	0.35	1.73	0.95	16.6	
2GD	59.3	128	137	226	198	222	9	19.5	3	2.5	0.35	1.74	0.96	17.8	
2CC	29.4	129	128	156	152	160	6	6	1.5	1.5	0.35	1.72	0.95	1.77	
4CB	34.6	134	130	156	155	164	4	7.5	2.5	2.5	0.47	1.27	0.70	1.76	
4DC	38.8	132	131	170	161	173	7	9	2	2	0.46	1.31	0.72	3.34	
2DE	36.2	132	132	170	160	171	6	10	2	2	0.31	1.97	1.08	4.16	
3FE	47.8	132	133	190	172	192	9	14	2	2	0.40	1.51	0.83	7.73	
4FB	44.2	134	140	203	187	203	6	9.5	2.5	2	0.44	1.38	0.76	6.36	
4FD	51.6	134	136	203	181	204	7	11.5	2.5	2	0.44	1.38	0.76	9.04	
—	77.8	138	145	246	219	239	6	21	3	2.5	0.81	0.74	0.41	13.0	
—	48.9	138	152	246	221	239	10	13.5	3	2.5	0.35	1.73	0.95	13.7	
2GB	50.2	138	152	246	221	239	10	13.5	3	2.5	0.35	1.74	0.96	14.5	
7GB	81.9	138	145	246	221	244	6	21	3	2.5	0.83	0.73	0.40	15.4	
2GD	62.7	138	148	246	213	239	9	21.5	3	2.5	0.35	1.74	0.96	22.2	
—	61.1	138	148	246	213	239	9	21.5	3	2.5	0.35	1.73	0.95	21.8	

Single-row tapered roller bearings metric series

d 130 ~ (150) mm

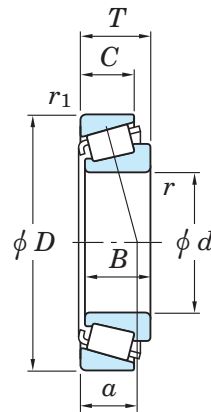

d	Boundary dimensions (mm)						Basic load ratings (kN)		Limiting speeds (min ⁻¹)		Bearing No.
	D	T	B	C	r min.	r_1 min.	C_r	C_{0r}	Grease lub.	Oil lub.	
130	180	32	32	25	2	1.5	200	368	1 900	2 500	32926JR
	185	29	27	21	3	3	183	282	1 800	2 500	T4CB130
	200	45	45	34	2.5	2	340	563	1 800	2 300	32026JR
	200	55	55	43	2.5	2	390	705	1 700	2 300	33026JR
	230	43.75	40	34	4	3	377	511	1 600	2 100	30226JR
	230	67.75	64	54	4	3	554	830	1 600	2 200	32226JR
	280	63.75	58	41	5	4	485	582	1 200	1 600	30326D
	280	63.75	58	49	5	4	657	834	1 400	1 800	30326JR
	280	72	66	44	5	4	589	748	1 200	1 600	31326JR
280	98.75	93	78	5	4	852	1 160	1 400	1 800	32326	
140	190	32	32	25	2	1.5	206	390	1 800	2 300	32928JR
	195	29	27	21	3	3	185	293	1 700	2 300	T4CB140
	210	45	45	34	2.5	2	346	585	1 700	2 200	32028JR
	210	56	56	44	2.5	2	406	758	1 600	2 200	33028JR
	250	45.75	42	36	4	3	420	570	1 500	1 900	30228JR
	250	71.75	68	58	4	3	636	961	1 500	2 000	32228JR
	300	67.75	62	44	5	4	525	627	1 100	1 500	30328D
	300	67.75	62	53	5	4	749	962	1 300	1 700	30328JR
	300	77	70	47	5	4	674	865	1 100	1 500	31328JR
300	107.75	102	85	5	4	1 110	1 570	1 300	1 700	32328R	
150	210	38	38	30	2.5	2	286	536	1 600	2 100	32930JR
	225	48	48	36	3	2.5	391	668	1 500	2 000	32030JR
	225	59	59	46	3	2.5	459	869	1 500	2 000	33030JR
	270	49	45	38	4	3	483	664	1 300	1 800	30230JR
	270	77	73	60	4	3	704	1 070	1 300	1 800	32230JR
	320	72	65	46	5	4	616	750	970	1 400	30330D
	320	72	65	55	5	4	837	1 080	1 200	1 500	30330JR

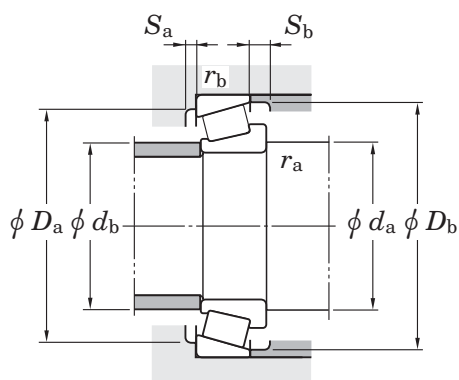

Dimension series to ISO355 (Refer.)	Load center (mm) a	Mounting dimensions (mm)										Constant e	Axial load factors		(Refer.) Mass (kg)
		d_a min.	d_b max.	D_a max.	D_b min.	S_a min.	S_b min.	r_a max.	r_b max.	Y_1	Y_0				
2CC	31.4	140	141	171	165	174	6	7	2	1.5	0.34	1.77	0.97	2.42	
4CB	37.8	144	141	171	170	179	5	8	2.5	2.5	0.47	1.27	0.70	2.22	
4EC	42.9	142	144	190	178	192	8	11	2	2	0.43	1.38	0.76	5.04	
2EE	42.5	142	143	190	178	192	8	12	2	2	0.34	1.76	0.97	6.19	
4FB	46.2	148	152	216	203	218	7	9.5	3	2.5	0.44	1.38	0.76	7.24	
4FD	56.0	148	146	216	193	219	7	13.5	3	2.5	0.44	1.38	0.76	11.5	
—	84.0	152	155	262	240	261	7	22	4	3	0.81	0.74	0.41	16.3	
2GB	54.0	152	164	262	239	255	8	14.5	4	3	0.35	1.74	0.96	18.1	
7GB	87.3	152	155	262	236	261	7	23	4	3	0.83	0.73	0.40	18.9	
—	69.1	152	163	262	226	259	10	15	4	3	0.35	1.73	0.95	26.5	
2CC	33.6	150	150	181	174	184	6	7	2	1.5	0.36	1.67	0.92	2.57	
4CB	40.9	154	151	181	180	189	5	8	2.5	2.5	0.50	1.19	0.66	2.36	
4DC	45.6	152	153	200	187	202	8	11	2	2	0.46	1.31	0.72	5.28	
2DE	45.6	152	152	200	186	202	7	12	2	2	0.36	1.67	0.92	6.61	
4FB	49.4	158	163	236	219	237	9	9.5	3	2.5	0.44	1.38	0.76	8.97	
4FD	60.0	158	158	236	210	238	9	13.5	3	2.5	0.44	1.38	0.76	14.7	
—	90.2	162	169	282	254	280	7	23	4	3	0.81	0.74	0.41	20.0	
2GB	56.9	162	179	282	254	273	10	14.5	4	3	0.35	1.74	0.96	22.6	
7GB	93.8	162	167	282	254	280	8	26	4	3	0.83	0.73	0.40	23.3	
—	74.2	162	175	282	246	280	10	17	4	3	0.35	1.74	0.96	35.1	
2DC	36.1	162	163	200	194	202	7	8	2	2	0.33	1.83	1.01	3.96	
4EC	48.8	164	164	213	200	216	8	12	2.5	2	0.46	1.31	0.72	6.41	
2EE	47.8	164	164	213	200	217	8	13	2.5	2	0.36	1.65	0.90	8.09	
4GB	52.4	168	175	256	234	255	9	11	3	2.5	0.44	1.38	0.76	11.6	
4GD	65.2	168	170	256	226	254	8	17	3	2.5	0.44	1.38	0.76	18.2	
—	96.0	172	183	302	270	301	9	26	4	3	0.81	0.74	0.41	23.9	
2GB	60.8	172	193	302	272	292	12	17	4	3	0.35	1.74	0.96	26.6	

Single-row tapered roller bearings metric series

d (150) ~ (190) mm

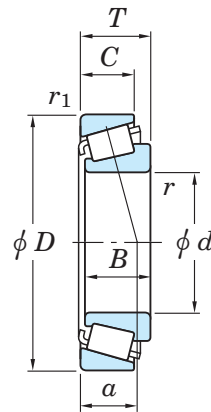

d	Boundary dimensions (mm)						Basic load ratings (kN)		Limiting speeds (min ⁻¹)		Bearing No.
	D	T	B	C	r min.	r_1 min.	C_r	C_{0r}	Grease lub.	Oil lub.	
150	320	82	75	50	5	4	763	989	980	1 400	31330JR 32330R
	320	114	108	90	5	4	1 240	1 790	1 200	1 600	
160	220	32	30	23	3	3	225	379	1 500	2 000	T4DB160 32932JR 32032JR 30232JR 32232JR 30332D 30332JR 32332
	220	38	38	30	2.5	2	295	568	1 500	2 000	
	240	51	51	38	3	2.5	440	758	1 400	1 900	
	290	52	48	40	4	3	542	750	1 200	1 600	
	290	84	80	67	4	3	795	1 210	1 200	1 700	
	340	75	68	48	5	4	742	933	900	1 300	
	340	75	68	58	5	4	938	1 220	1 100	1 400	
	340	121	114	95	5	4	1 220	1 720	1 100	1 400	
170	230	38	38	30	2.5	2	296	606	1 400	1 900	32934JR 32034JR 30234JR 32234JR 30334D 30334JR 32334
	260	57	57	43	3	2.5	526	905	1 300	1 700	
	310	57	52	43	5	4	620	867	1 100	1 500	
	310	91	86	71	5	4	898	1 380	1 100	1 500	
	360	80	72	50	5	4	762	1 040	830	1 200	
	360	80	72	62	5	4	1 040	1 370	1 000	1 300	
	360	127	120	100	5	4	1 310	1 830	1 000	1 300	
	180	250	45	45	34	2.5	2	357	735	1 300	
280		64	64	48	3	2.5	644	1 100	1 200	1 600	
320		57	52	43	5	4	615	870	1 100	1 400	
320		91	86	71	5	4	957	1 520	1 100	1 500	
380		83	75	52	5	4	833	1 150	780	1 100	
380		83	75	64	5	4	901	1 110	940	1 300	
380		134	126	106	5	4	1 410	1 980	960	1 300	
190		260	45	45	34	2.5	2	366	789	1 200	1 600
	290	64	64	48	3	2.5	654	1 170	1 100	1 500	

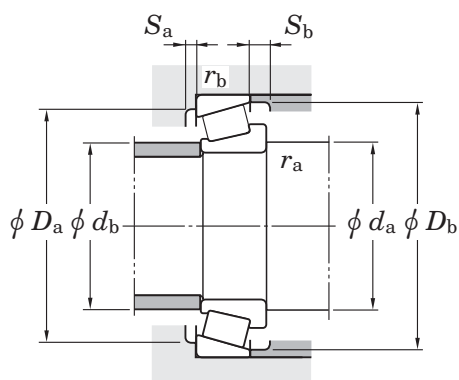

Dimension series to ISO355 (Refer.)	Load center (mm) a	Mounting dimensions (mm)										Con-stant e	Axial load factors		(Refer.) Mass (kg)
		d_a min.	d_b max.	D_a max.	D_b min.	S_a min.	S_b min.	r_a max.	r_b max.	Y_1	Y_0				
7GB —	100.1 78.4	172 172	179 187	302 302	272 263	301 298	9 10	27 17	4 4	3 3	0.83 0.35	0.73 1.74	0.40 0.96	28.0 42.0	
4DB	44.7	174	172	206	204	213	5	9	2.5	2.5	0.49	1.23	0.68	3.23	
2DC	38.4	172	173	210	204	212	7	8	2	2	0.35	1.73	0.95	4.19	
4EC	52.1	174	175	228	213	231	8	13	2.5	2	0.46	1.31	0.72	7.75	
4GB	56.3	178	189	276	252	269	8	12	3	2.5	0.44	1.38	0.76	14.1	
4GD	70.3	178	182	276	242	274	10	17	3	2.5	0.44	1.38	0.76	23.2	
—	101.8	182	195	322	290	320	9	27	4	3	0.81	0.74	0.41	29.1	
2GB	63.3	182	205	322	289	310	12	17	4	3	0.35	1.74	0.96	31.8	
—	83.0	182	200	322	277	316	10	18	4	3	0.35	1.73	0.95	47.9	
3DC	42.0	182	183	220	213	222	7	8	2	2	0.38	1.57	0.86	4.49	
4EC	55.8	184	187	248	230	249	10	14	2.5	2	0.44	1.35	0.74	10.5	
4GB	61.2	192	202	292	269	288	8	14	4	3	0.44	1.38	0.76	17.8	
4GD	76.2	192	195	292	259	294	10	20	4	3	0.44	1.38	0.76	28.9	
—	108.3	192	211	342	310	333	9	30	4	3	0.81	0.74	0.41	34.3	
2GB	67.9	192	218	342	306	329	13	18	4	3	0.35	1.74	0.96	37.5	
—	86.1	192	200	342	295	337	14	26	4	3	0.35	1.73	0.95	56.9	
4DC	53.5	192	193	240	225	241	8	11	2	2	0.48	1.25	0.69	6.64	
3FD	59.5	194	199	268	247	268	10	16	2.5	2	0.42	1.42	0.78	14.1	
4GB	63.6	202	211	302	278	297	9	14	4	3	0.45	1.33	0.73	18.3	
4GD	77.8	202	204	302	267	303	10	20	4	3	0.45	1.33	0.73	29.9	
—	112.8	202	225	362	330	351	10	31	4	3	0.81	0.74	0.41	40.1	
—	71.0	202	227	362	318	346	13	19	4	3	0.35	1.73	0.95	39.7	
—	91.8	202	215	362	310	355	14	27	4	3	0.35	1.73	0.95	67.0	
4DC	55.0	202	204	250	235	252	8	11	2	2	0.48	1.26	0.69	6.89	
4FD	62.9	204	209	278	257	279	10	16	2.5	2	0.44	1.36	0.75	14.7	

Single-row tapered roller bearings metric series

d (190) ~ 260 mm

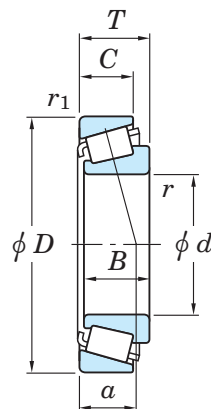

d	Boundary dimensions (mm)						Basic load ratings (kN)		Limiting speeds (min ⁻¹)		Bearing No.
	D	T	B	C	r min.	r_1 min.	C_r	C_{0r}	Grease lub.	Oil lub.	
190	340	60	55	46	5	4	729	1 030	1 000	1 300	30238JR
	340	97	92	75	5	4	1 090	1 740	1 000	1 300	32238JR
	400	86	78	52	6	5	950	1 210	740	1 000	30338D
	400	86	78	65	6	5	1 010	1 250	880	1 200	30338
	400	140	132	109	6	5	1 550	2 190	890	1 200	32338
200	280	51	51	39	3	2.5	486	958	1 100	1 500	32940JR
	310	70	70	53	3	2.5	755	1 340	1 100	1 400	32040JR
	360	64	58	48	5	4	792	1 120	940	1 200	30240JR
	360	104	98	82	5	4	1 240	1 880	960	1 300	32240JR
	420	89	80	56	6	5	904	1 230	690	970	30340D
	420	89	80	67	6	5	1 120	1 450	820	1 100	30340
	420	146	138	115	6	5	1 790	2 580	830	1 100	32340
220	300	51	51	39	3	2.5	498	1 010	1 000	1 400	32944JR
	340	76	76	57	4	3	894	1 620	940	1 300	32044JR
	400	72	65	54	5	4	1 010	1 440	830	1 100	30244JR
	400	114	108	90	5	4	1 190	1 930	830	1 100	32244
	460	97	88	73	6	5	1 260	1 680	730	980	30344
240	320	51	51	39	3	2.5	515	1 090	940	1 300	32948JR
	360	76	76	57	4	3	924	1 720	870	1 200	32048JR
	440	79	72	60	5	4	1 230	1 790	730	980	30248R
	440	127	120	100	5	4	1 530	2 480	740	980	32248
260	360	63.5	63.5	48	3	2.5	741	1 550	830	1 100	32952JR
	400	87	87	65	5	4	1 170	2 170	770	1 000	32052JR
	480	89	80	67	6	5	1 210	1 860	650	870	30252
	480	137	130	106	6	5	1 760	2 870	660	880	32252

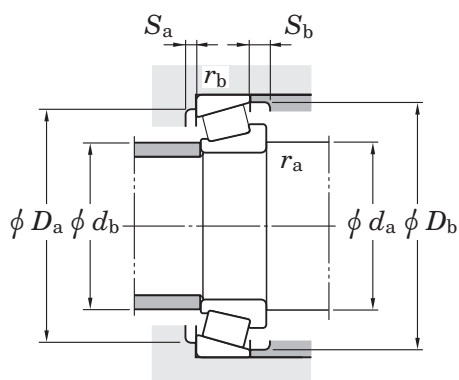

Dimension series to ISO355 (Refer.)	Load center (mm) a	Mounting dimensions (mm)										Con-stant e	Axial load factors		(Refer.) Mass (kg)
		d_a min.	d_b max.	D_a max.	D_b min.	S_a min.	S_b min.	r_a max.	r_b max.	Y_1	Y_0				
4GB	66.4	212	225	322	298	318	12	13	4	3	0.44	1.38	0.76	21.9	
4GD	81.9	212	216	322	286	323	12	22	4	3	0.44	1.38	0.76	36.6	
—	119.2	218	232	378	350	372	11	34	5	4	0.81	0.74	0.41	44.8	
—	73.2	218	241	378	342	370	10	20	5	4	0.35	1.73	0.95	46.2	
—	96.5	218	225	378	330	375	14	30	5	4	0.35	1.73	0.95	76.6	
3EC	53.6	214	216	268	257	271	9	12	2.5	2	0.39	1.52	0.84	9.44	
4FD	66.9	214	221	298	273	297	11	17	2.5	2	0.43	1.39	0.77	19.1	
4GB	70.3	222	238	342	315	336	12	15	4	3	0.44	1.38	0.76	26.4	
3GD	84.6	222	225	342	302	340	11	22	4	3	0.41	1.48	0.81	44.2	
—	122.6	228	248	398	365	385	11	33	5	4	0.81	0.74	0.41	50.6	
—	79.8	228	255	398	354	385	11	21	5	4	0.35	1.73	0.95	53.5	
—	102.9	228	240	398	345	395	16	30	5	4	0.35	1.73	0.95	91.0	
3EC	58.6	234	234	288	275	290	9	12	2.5	2	0.43	1.41	0.78	10.1	
4FD	72.8	238	243	326	300	326	12	19	3	2.5	0.43	1.39	0.77	25.2	
—	76.5	242	263	382	344	371	14	17	4	3	0.44	1.43	0.79	35.9	
—	95.9	242	260	382	333	377	16	14	4	3	0.43	1.39	0.77	56.8	
—	84.6	248	282	438	386	420	12	23	5	4	0.35	1.73	0.95	69.0	
4EC	64.5	254	254	308	294	311	9	12	2.5	2	0.46	1.31	0.72	10.9	
4FD	78.5	258	261	346	318	346	12	19	3	2.5	0.46	1.31	0.72	26.8	
—	82.7	262	287	422	377	409	14	18	4	3	0.42	1.43	0.79	49.5	
—	106.1	262	282	422	365	415	16	14	4	3	0.43	1.39	0.77	76.4	
3EC	69.6	274	279	348	328	347	11	15.5	2.5	2	0.41	1.48	0.81	18.9	
4FC	85.0	282	287	382	352	383	14	22	4	3	0.43	1.38	0.76	39.5	
—	93.6	288	310	458	415	450	14	21	5	4	0.42	1.44	0.79	64.9	
—	115.2	288	300	458	400	455	16	30	5	4	0.43	1.39	0.77	102	

Single-row tapered roller bearings metric series

d 280 ~ 360 mm

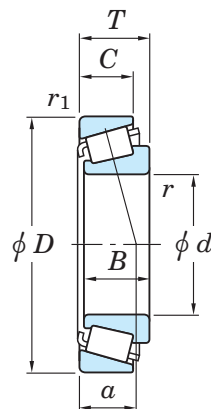

d	Boundary dimensions (mm)						Basic load ratings (kN)		Limiting speeds (min^{-1})		Bearing No.
	D	T	B	C	r min.	r_1 min.	C_r	C_{0r}	Grease lub.	Oil lub.	
280	380	63.5	63.5	48	3	2.5	760	1 630	770	1 000	32956JR
	420	87	87	65	5	4	1 200	2 280	720	960	32056JR
	500	89	80	67	6	5	1 260	1 920	610	810	30256
	500	137	130	106	6	5	1 860	3 150	610	810	32256
300	420	76	76	57	4	3	1 050	2 210	680	910	32960JR
	460	100	100	74	5	4	1 430	2 660	640	850	32060JR
	540	96	85	71	6	5	1 510	2 360	550	730	30260
320	440	76	76	57	4	3	1 060	2 270	640	850	32964JR
	480	100	100	74	5	4	1 510	2 810	600	800	32064JR
	580	104	92	75	6	5	1 740	2 770	490	660	30264
340	460	76	76	57	4	3	1 070	2 340	590	790	32968JR
360	480	76	76	57	4	3	1 080	2 400	560	740	32972JR

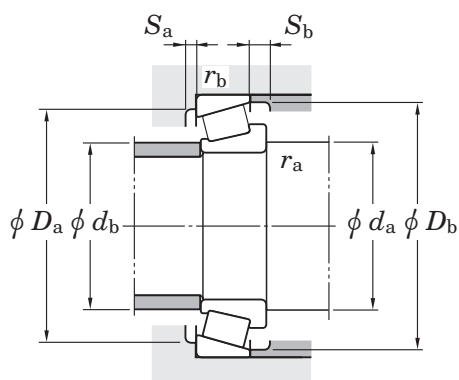

Dimension series to ISO355 (Refer.)	Load center (mm) a	Mounting dimensions (mm)										Con-stant e	Axial load factors		(Refer.) Mass (kg)
		d_a min.	d_b max.	D_a max.	D_b min.	S_a min.	S_b min.	r_a max.	r_b max.	Y_1	Y_0				
4EC	75.1	294	298	368	347	368	11	15.5	2.5	2	0.43	1.39	0.76	20.1	
4FC	91.1	302	305	402	370	402	14	22	4	3	0.46	1.31	0.72	41.7	
—	96.2	308	325	478	440	475	14	21	5	4	0.42	1.44	0.79	67.6	
—	117.2	308	325	478	420	474	16	30	5	4	0.43	1.39	0.77	108	
3FD	79.9	318	324	406	383	405	12	19	3	2.5	0.39	1.52	0.84	32.4	
4GD	97.9	322	329	442	404	439	15	26	4	3	0.43	1.38	0.76	57.5	
—	103.9	328	350	518	475	505	14	24	5	4	0.42	1.44	0.79	84.7	
3FD	85.0	338	342	426	401	426	12	19	3	2.5	0.42	1.44	0.79	34.0	
4GD	103.0	342	344	462	418	461	16	26	4	3	0.46	1.31	0.72	58.7	
—	111.9	348	370	558	505	540	14	28	5	4	0.42	1.44	0.79	108	
4FD	90.5	358	361	446	420	446	12	19	3	2.5	0.44	1.37	0.75	35.6	
4FD	96.2	378	379	466	438	466	12	19	3	2.5	0.46	1.31	0.72	37.1	

Single-row tapered roller bearings inch series

d 9.525 ~ (22.225) mm

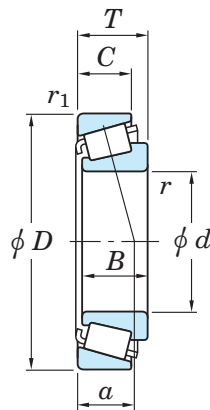

d	Boundary dimensions (mm)						Basic load ratings (kN)		Limiting speeds (min ⁻¹)	
	D	T	B	C	r min.	r_1 min.	C_r	C_{0r}	Grease lub.	Oil lub.
9.525	31.991	10.008	10.785	7.938	1.2	1.2	10.7	9.30	14 000	19 000
11.986	31.991	10.008	10.785	7.938	0.8	1.2	10.7	9.30	14 000	19 000
12.700	34.988	10.998	10.988	8.730	1.2	1.2	12.6	11.9	12 000	17 000
14.989	34.988	10.998	10.988	8.730	0.8	1.2	12.6	11.9	12 000	17 000
15.875	34.988	10.998	10.998	8.712	1.2	1.2	14.5	14.3	12 000	16 000
	41.275	14.288	14.681	11.112	1.2	2.0	21.8	20.5	11 000	14 000
	42.862	16.670	16.670	13.495	1.6	1.6	30.6	29.5	10 000	14 000
	49.225	19.845	21.539	14.288	0.8	1.2	37.7	37.7	8 900	12 000
	53.975	22.225	21.839	15.875	0.8	2.4	42.0	41.2	8 400	11 000
16.000	47.000	21.000	21.000	16.000	1.0	2.0	36.3	37.7	9 800	13 000
17.462	39.878	13.843	14.605	10.668	1.2	1.2	25.4	26.0	11 000	14 000
19.050	45.237	15.494	16.637	12.065	1.2	1.2	29.4	30.1	9 400	13 000
	49.225	19.845	21.539	14.288	1.2	1.2	37.7	37.7	8 900	12 000
	49.225	21.209	19.050	17.462	1.2	1.6	37.7	37.7	8 900	12 000
20.000	50.005	13.495	14.260	9.525	1.6	1.0	26.7	28.8	7 900	11 000
20.638	49.225	19.845	19.845	15.875	1.6	1.6	36.4	37.7	8 600	12 000
21.430	50.005	17.526	18.288	13.970	1.2	1.2	39.1	40.7	8 500	11 000
21.987	45.974	15.494	16.637	12.065	1.2	1.2	30.1	34.6	8 900	12 000
22.225	50.005	17.526	18.288	13.970	1.2	1.2	39.1	40.7	8 500	11 000
	52.388	19.368	20.168	14.288	1.6	1.6	36.7	37.9	8 000	11 000
	53.975	19.368	20.168	14.288	1.6	1.6	36.7	37.9	8 000	11 000

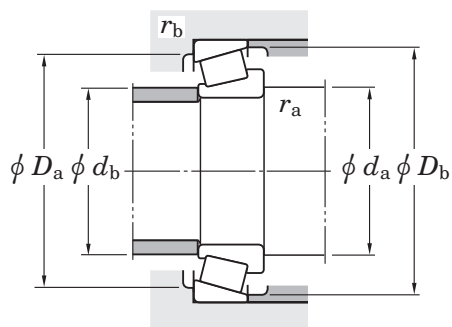

	Bearing No.		Load center (mm) <i>a</i>	Mounting dimensions (mm)						Constant <i>e</i>	Axial load factors		(Refer.) Mass (kg)	
	Inner ring	Outer ring		<i>d_a</i>	<i>d_b</i>	<i>D_a</i>	<i>D_b</i>	<i>r_a</i> max.	<i>r_b</i> max.		<i>Y₁</i>	<i>Y₀</i>	Inner ring	Outer ring
	A2037	A2126	7.1	15.0	13.5	26.0	29.0	1.2	1.2	0.40	1.48	0.82	0.029	0.017
	A2047	A2126	7.1	16.5	15.5	26.0	29.0	0.8	1.2	0.40	1.48	0.82	0.023	0.017
	A4050	A4138	8.3	18.5	17.0	29.0	32.0	1.2	1.2	0.45	1.33	0.73	0.033	0.022
	A4059	A4138	8.3	19.5	19.0	29.0	32.0	0.8	1.2	0.45	1.33	0.73	0.029	0.022
	L21549	L21511	7.6	21.5	19.5	29.0	32.5	1.2	1.2	0.32	1.88	1.04	0.031	0.018
	03062	03162	9.3	21.5	20.0	34.0	37.5	1.2	2.0	0.31	1.93	1.06	0.060	0.035
	17580R	17520	10.9	23.0	21.0	36.5	39.0	1.6	1.6	0.33	1.81	1.00	0.078	0.048
	09062	09195	10.6	22.0	21.5	42.0	44.5	0.8	1.2	0.27	2.26	1.24	0.139	0.065
	21063	21212	16.6	29.0	26.5	43.0	50.0	0.8	2.4	0.59	1.02	0.56	0.163	0.097
	HM81649	HM81610	15.0	27.5	23.0	37.5	43.0	1.0	2.0	0.55	1.10	0.60	0.111	0.080
	LM11749R	LM11710	8.6	23.0	21.5	34.0	37.0	1.2	1.2	0.29	2.10	1.15	0.058	0.028
	LM11949	LM11910	10.0	25.0	23.5	39.5	41.5	1.2	1.2	0.30	2.00	1.10	0.081	0.044
	09078	09195	10.6	25.5	24.0	42.0	44.5	1.2	1.2	0.27	2.26	1.24	0.124	0.065
	09067	09196	13.8	25.5	24.0	41.5	44.5	1.2	1.6	0.27	2.26	1.24	0.114	0.084
	07079	07196	10.8	27.5	26.0	44.5	47.0	1.6	1.0	0.40	1.49	0.82	0.104	0.034
	12580	12520	12.7	28.5	26.0	42.5	45.5	1.6	1.6	0.32	1.86	1.02	0.116	0.067
	M12649	M12610	11.1	27.5	25.5	44.0	46.0	1.2	1.2	0.28	2.16	1.19	0.119	0.058
	LM12749	LM12711	10.0	27.5	26.0	40.0	42.5	1.2	1.2	0.31	1.96	1.08	0.078	0.043
	M12648	M12610	11.1	28.5	26.5	44.0	46.0	1.2	1.2	0.28	2.16	1.19	0.115	0.058
	1380	1328	11.6	29.5	29.5	45.0	48.5	1.6	1.6	0.29	2.05	1.13	0.132	0.066
	1380	1329	11.6	29.5	29.5	46.0	49.0	1.6	1.6	0.29	2.05	1.13	0.137	0.082

[Remark] Inch series tapered roller bearings with bore diameter larger than 100 mm are shown in catalog "large size ball & roller bearings".

Single-row tapered roller bearings inch series

d (22.225) ~ (26.988) mm

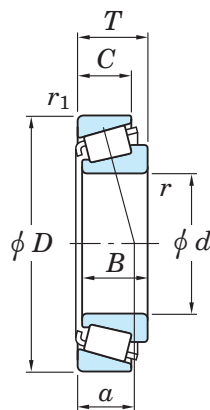

d	Boundary dimensions (mm)						Basic load ratings (kN)		Limiting speeds (min ⁻¹)	
	D	T	B	C	r min.	r_1 min.	C_r	C_{0r}	Grease lub.	Oil lub.
22.225	56.896	19.368	19.837	15.875	1.2	1.2	40.0	43.1	7 600	10 000
	57.150	22.225	22.225	17.462	0.8	1.6	52.6	55.7	7 600	10 000
	66.421	23.812	25.433	19.050	1.6	1.2	67.0	75.2	6 500	8 700
22.606	47.000	15.500	15.500	12.000	1.6	1.0	28.0	32.8	8 700	12 000
23.812	50.292	14.224	14.732	10.668	1.6	1.2	31.2	37.0	7 800	10 000
	56.896	19.368	19.837	15.875	0.8	1.2	40.0	43.1	7 600	10 000
24.981	50.005	13.495	14.260	9.525	1.6	1.0	26.7	28.8	7 900	11 000
	62.000	16.002	16.566	14.288	1.6	1.6	38.0	40.6	6 700	8 900
25.000	50.005	13.495	14.260	9.525	1.6	1.0	26.7	28.8	7 900	11 000
25.400	50.005	13.495	14.260	9.525	1.0	1.0	26.7	28.8	7 900	11 000
	50.005	13.495	14.260	9.525	1.6	1.0	26.7	28.8	7 900	11 000
	50.292	14.224	14.732	10.668	1.2	1.2	31.2	37.0	7 800	10 000
	51.994	15.011	14.260	12.700	1.0	1.2	26.7	28.8	7 900	11 000
	58.738	19.050	19.355	15.080	1.2	1.2	48.8	57.1	7 000	9 300
	59.530	23.368	23.114	18.288	0.8	1.6	50.4	57.1	7 200	9 600
	61.912	19.050	20.638	14.288	0.8	2.0	44.6	50.7	6 400	8 600
	62.000	19.050	20.638	14.288	3.6	1.2	44.6	50.7	6 400	8 600
	63.500	19.050	20.638	14.288	0.8	1.2	44.6	50.7	6 400	8 600
	64.292	21.432	21.432	16.670	1.6	1.6	55.2	70.7	6 400	8 500
	66.421	23.812	25.433	19.050	1.2	1.2	67.0	75.2	6 500	8 700
	68.262	22.225	22.225	17.462	0.8	1.6	51.0	61.1	6 000	8 000
72.233	25.400	25.400	19.842	0.8	2.4	66.9	87.4	5 700	7 600	
26.162	66.421	23.812	25.433	19.050	1.6	1.2	67.0	75.2	6 500	8 700
26.988	50.292	14.224	14.732	10.668	3.6	1.2	31.2	37.0	7 800	10 000

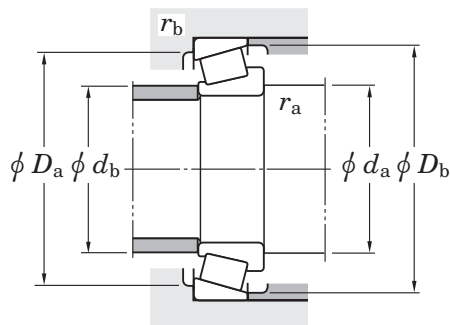

	Bearing No.		Load center (mm) a	Mounting dimensions (mm)						Constant e	Axial load factors		(Refer.) Mass (kg)	
	Inner ring	Outer ring		d_a	d_b	D_a	D_b	r_a max.	r_b max.		Y_1	Y_0	Inner ring	Outer ring
	1755	1729	12.5	29.0	27.5	49.0	51.0	1.2	1.2	0.31	1.95	1.07	0.150	0.100
	1280	1220	15.3	29.5	29.0	49.0	52.0	0.8	1.6	0.35	1.73	0.95	0.189	0.105
	2684	2631	13.9	31.5	29.0	58.0	60.0	1.6	1.2	0.25	2.36	1.30	0.295	0.163
	LM72849	LM72810	12.3	30.0	28.0	40.5	44.0	1.6	1.0	0.47	1.27	0.70	0.076	0.047
	L44640R	L44610	10.8	30.5	28.5	44.5	47.0	1.6	1.2	0.37	1.60	0.88	0.099	0.034
	1779	1729	12.5	29.5	28.5	49.0	51.0	0.8	1.2	0.31	1.95	1.07	0.141	0.100
	07098	07196	10.8	31.0	29.0	44.5	47.0	1.6	1.0	0.40	1.49	0.82	0.084	0.034
	17098	17244	12.7	33.0	30.5	54.0	57.0	1.6	1.6	0.38	1.57	0.86	0.162	0.090
	07097	07196	10.8	31.0	29.0	44.5	47.0	1.6	1.0	0.40	1.49	0.82	0.085	0.035
	07100	07196	10.8	30.5	29.5	44.5	47.0	1.0	1.0	0.40	1.49	0.82	0.084	0.035
	07100S	07196	10.8	31.5	29.5	44.5	47.0	1.6	1.0	0.40	1.49	0.82	0.082	0.035
	L44643R	L44610	10.8	31.5	29.5	44.5	47.0	1.2	1.2	0.37	1.60	0.88	0.092	0.039
	07100	07204	12.3	30.5	29.5	45.0	48.0	1.0	1.2	0.40	1.49	0.82	0.075	0.065
	1986R	1932	13.1	32.5	30.5	52.0	54.0	1.2	1.2	0.33	1.82	1.00	0.179	0.088
	M84249	M84210	18.2	36.0	32.5	49.5	56.0	0.8	1.6	0.55	1.10	0.60	0.194	0.128
	15101	15243	13.2	32.5	31.5	55.0	58.0	0.8	2.0	0.35	1.71	0.94	0.215	0.080
	15100	15245	13.2	38.0	31.5	55.0	58.0	3.6	1.2	0.35	1.71	0.94	0.215	0.081
	15101	15250R	13.2	32.5	31.5	55.0	59.0	0.8	1.2	0.35	1.71	0.94	0.215	0.097
	M86643R	M86610	18.0	38.0	36.5	54.0	61.0	1.6	1.6	0.55	1.10	0.60	0.248	0.127
	2687	2631	13.9	33.5	31.5	58.0	60.0	1.2	1.2	0.25	2.36	1.30	0.272	0.163
	02473	02420	17.1	34.5	33.5	59.0	63.0	0.8	1.6	0.42	1.44	0.79	0.275	0.150
	HM88630	HM88610	20.7	39.5	39.5	60.0	69.0	0.8	2.4	0.55	1.10	0.60	0.391	0.185
	2682	2631	13.9	34.5	32.0	58.0	60.0	1.6	1.2	0.25	2.36	1.30	0.268	0.163
	L44649R	L44610	10.8	37.5	31.0	44.5	47.0	3.6	1.2	0.37	1.60	0.88	0.083	0.039

[Remark] Inch series tapered roller bearings with bore diameter larger than 100 mm are shown in catalog "large size ball & roller bearings".

Single-row tapered roller bearings inch series

d (26.988) ~ (30.162) mm

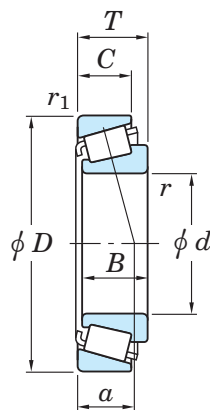

d	Boundary dimensions (mm)						Basic load ratings (kN)		Limiting speeds (min ⁻¹)	
	D	T	B	C	r min.	r_1 min.	C_r	C_{0r}	Grease lub.	Oil lub.
26.988	60.325	19.842	17.462	15.875	3.6	1.6	37.8	42.7	7 000	9 400
	62.000	19.050	20.638	14.288	0.8	1.2	44.6	50.7	6 400	8 600
	66.421	23.812	25.433	19.050	1.6	1.2	67.0	75.2	6 500	8 700
28.575	57.150	17.462	17.462	13.495	3.6	1.6	37.8	42.7	7 000	9 400
	57.150	19.845	19.355	15.875	3.6	1.6	48.8	57.1	7 000	9 300
	62.000	19.050	20.638	14.288	3.6	1.2	44.6	50.7	6 400	8 600
	62.000	19.050	20.638	14.288	0.8	1.2	44.6	50.7	6 400	8 600
	64.292	21.432	21.432	16.670	1.6	1.6	55.2	70.7	6 400	8 500
	66.421	23.812	25.433	19.050	1.2	1.2	67.0	75.2	6 500	8 700
	68.262	22.225	22.225	17.462	0.8	1.6	51.0	61.1	6 000	8 000
	72.000	19.000	18.923	15.875	1.6	1.6	47.5	49.6	5 900	7 800
	72.626	24.608	24.257	17.462	4.8	1.6	61.8	60.5	6 100	8 100
	72.626	24.608	24.257	17.462	1.6	1.6	61.8	60.5	6 100	8 100
	72.626	30.162	29.997	23.812	3.6	3.2	78.8	89.3	5 800	7 700
	72.626	30.162	29.997	23.812	1.2	3.2	78.8	89.3	5 800	7 700
73.025	22.225	22.225	17.462	0.8	3.2	55.0	65.7	5 500	7 400	
29.000	50.292	14.224	14.732	10.668	3.6	1.2	28.9	37.2	7 600	10 000
29.367	66.421	23.812	25.433	19.050	3.6	1.2	67.0	75.2	6 500	8 700
29.987	62.000	16.002	16.566	14.288	1.6	1.6	38.0	40.6	6 700	8 900
	62.000	19.050	20.638	14.288	1.2	1.2	44.6	50.7	6 400	8 600
30.000	69.012	19.845	19.583	15.875	3.6	1.2	46.1	55.0	5 900	7 800
30.112	62.000	19.050	20.638	14.288	0.8	1.2	44.6	50.7	6 400	8 600
30.162	62.000	16.002	16.566	14.288	1.6	1.6	38.0	40.6	6 700	8 900
	64.292	21.432	21.432	16.670	1.6	1.6	55.2	70.7	6 400	8 500

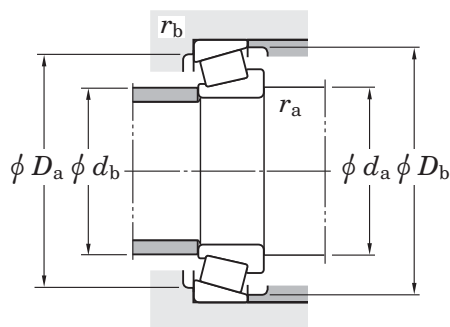

	Bearing No.		Load center (mm) a	Mounting dimensions (mm)						Constant e	Axial load factors		(Refer.) Mass (kg)	
	Inner ring	Outer ring		d_a	d_b	D_a	D_b	r_a max.	r_b max.		Y_1	Y_0	Inner ring	Outer ring
	15580	15523	15.1	38.5	32.0	51.0	54.0	3.6	1.6	0.35	1.73	0.95	0.140	0.122
	15106	15245	13.2	33.5	33.0	55.0	58.0	0.8	1.2	0.35	1.71	0.94	0.206	0.081
	2688	2631	13.9	35.0	33.0	58.0	60.0	1.6	1.2	0.25	2.36	1.30	0.262	0.163
	15590	15520	12.7	39.0	33.5	51.0	53.0	3.6	1.6	0.35	1.73	0.95	0.131	0.069
	1988R	1922	13.9	39.5	33.5	51.0	53.5	3.6	1.6	0.33	1.82	1.00	0.151	0.076
	15112	15245	13.2	40.0	34.0	55.0	58.0	3.6	1.2	0.35	1.71	0.94	0.193	0.081
	15113	15245	13.2	34.5	34.0	55.0	58.0	0.8	1.2	0.35	1.71	0.94	0.195	0.081
	M86647R	M86610	18.0	40.0	38.0	54.0	61.0	1.6	1.6	0.55	1.10	0.60	0.225	0.127
	2689	2631	13.9	36.0	34.0	58.0	60.0	1.2	1.2	0.25	2.36	1.30	0.249	0.165
	02474	02420	17.1	36.5	36.0	59.0	63.0	0.8	1.6	0.42	1.44	0.79	0.252	0.150
	26112	26283	15.3	37.0	35.0	62.0	65.0	1.6	1.6	0.36	1.67	0.92	0.217	0.163
	41125	41286	20.7	48.0	36.5	61.0	68.0	4.8	1.6	0.60	1.00	0.55	0.292	0.177
	41126	41286	20.7	41.5	36.5	61.0	68.0	1.6	1.6	0.60	1.00	0.55	0.295	0.177
	3192	3120	20.3	42.5	37.0	61.0	67.0	3.6	3.2	0.33	1.80	0.99	0.401	0.222
	3198	3120	20.3	39.0	37.0	61.0	67.0	1.2	3.2	0.33	1.80	0.99	0.410	0.222
	02872	02820	18.4	37.5	37.0	62.0	68.0	0.8	3.2	0.45	1.32	0.73	0.319	0.158
	L45449	L45410	10.9	39.5	33.0	44.5	48.0	3.6	1.2	0.37	1.62	0.89	0.079	0.036
	2690	2631	13.9	41.0	35.0	58.0	60.0	3.6	1.2	0.25	2.36	1.30	0.242	0.165
	17118	17244	12.7	37.0	34.5	54.0	57.0	1.6	1.6	0.38	1.57	0.86	0.135	0.090
	15117	15245	13.2	36.5	35.0	55.0	58.0	1.2	1.2	0.35	1.71	0.94	0.184	0.081
	14117A	14276	15.5	42.5	39.5	60.0	63.0	3.6	1.2	0.38	1.57	0.86	0.225	0.135
	15116	15245	13.2	36.0	35.5	55.0	58.0	0.8	1.2	0.35	1.71	0.94	0.184	0.081
	17119	17244	12.7	37.0	34.5	54.0	57.0	1.6	1.6	0.38	1.57	0.86	0.139	0.091
	M86649R	M86610	18.0	41.0	38.0	54.0	61.0	1.6	1.6	0.55	1.10	0.60	0.213	0.127

[Remark] Inch series tapered roller bearings with bore diameter larger than 100 mm are shown in catalog "large size ball & roller bearings".

Single-row tapered roller bearings inch series

d (30.162) ~ (34.925) mm

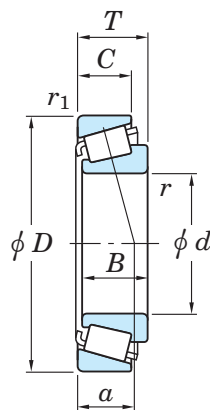

d	Boundary dimensions (mm)						Basic load ratings (kN)		Limiting speeds (min ⁻¹)	
	D	T	B	C	$r^{1)}$ min.	r_1 min.	C_r	C_{0r}	Grease lub.	Oil lub.
30.162	68.262	22.225	22.225	17.462	2.4	1.6	56.1	71.1	6 000	7 900
30.213	62.000	19.050	20.638	14.288	3.6	1.2	44.6	50.7	6 400	8 600
	62.000	19.050	20.638	14.288	1.6	1.2	44.6	50.7	6 400	8 600
	62.000	19.050	20.638	14.288	0.8	1.2	44.6	50.7	6 400	8 600
30.226	69.012	19.845	19.583	15.875	0.8	3.2	46.1	55.0	5 900	7 800
31.750	58.738	14.684	15.080	10.716	1.0	1.0	29.5	33.3	6 600	8 900
	59.131	15.875	16.764	11.811	SP	1.2	35.8	43.1	6 600	8 800
	62.000	18.161	19.050	14.288	SP	1.2	44.6	50.7	6 400	8 600
	62.000	19.050	20.638	14.288	3.6	1.2	44.6	50.7	6 400	8 600
	62.000	19.050	20.638	14.288	0.8	1.2	44.6	50.7	6 400	8 600
	66.421	25.400	25.357	20.638	0.8	3.2	71.4	85.1	6 000	8 000
	68.262	22.225	22.225	17.462	3.6	1.6	51.0	61.1	6 000	8 000
	68.262	22.225	22.225	17.462	0.8	1.6	51.0	61.1	6 000	8 000
	68.262	22.225	22.225	17.462	1.6	1.6	56.1	71.1	6 000	7 900
	73.025	22.225	22.225	17.462	3.6	3.2	55.0	65.7	5 600	7 400
	73.025	22.225	22.225	17.462	0.8	3.2	55.0	65.7	5 500	7 400
	73.025	29.370	27.783	23.020	1.2	3.2	74.3	101	5 600	7 500
73.812	29.370	27.783	23.020	1.2	3.2	74.3	101	5 600	7 500	
33.338	68.262	22.225	22.225	17.462	0.8	1.6	56.1	71.1	6 000	7 900
	72.000	19.000	18.923	15.875	3.6	1.6	47.5	49.6	5 900	7 800
	73.025	29.370	27.783	23.020	0.8	3.2	74.3	101	5 600	7 500
	76.200	29.370	28.575	23.020	0.8	3.2	79.5	107	5 400	7 200
34.925	65.088	18.034	18.288	13.970	SP	1.2	48.0	58.5	6 000	8 000
	69.012	26.982	26.721	15.875	0.8	1.2	46.1	55.0	5 900	7 800
	72.233	25.400	25.400	19.842	2.4	2.4	66.9	87.4	5 700	7 600

[Note] 1) SP indicates the specially chamfered from.

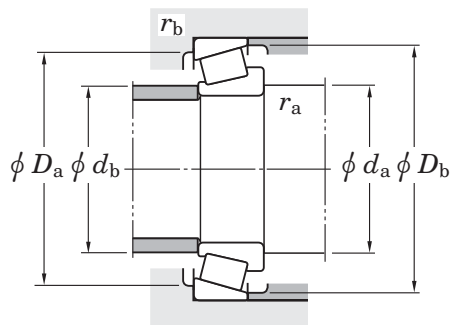

Bearing No.	Load center (mm)	Mounting dimensions (mm)								Constant	Axial load factors		(Refer.) Mass (kg)	
		Inner ring	Outer ring	d_a	d_b	D_a	D_b	r_a max.	r_b max.		e	Y_1	Y_0	Inner ring
M88043	M88010	19.2	43.5	39.5	58.0	65.0	2.4	1.6	0.55	1.10	0.60	0.258	0.144	
15118	15245	13.2	41.5	35.5	55.0	58.0	3.6	1.2	0.35	1.71	0.94	0.181	0.081	
15119	15245	13.2	37.5	35.5	55.0	58.0	1.6	1.2	0.35	1.71	0.94	0.183	0.081	
15120	15245	13.2	36.0	35.5	55.0	58.0	0.8	1.2	0.35	1.71	0.94	0.183	0.081	
14116	14274	15.5	37.0	36.5	59.0	63.0	0.8	3.2	0.38	1.57	0.86	0.226	0.131	
08125	08231	13.5	37.5	36.0	52.0	55.0	1.0	1.0	0.48	1.26	0.69	0.109	0.056	
LM67048	LM67010	13.0	42.5	36.0	52.0	56.0	3.5	1.2	0.41	1.46	0.80	0.120	0.062	
15123	15245	13.2	42.5	36.5	55.0	58.0	3.5	1.2	0.35	1.71	0.94	0.157	0.081	
15125	15245	13.2	42.5	36.5	55.0	58.0	3.6	1.2	0.35	1.71	0.94	0.169	0.081	
15126	15245	13.2	37.0	36.5	55.0	58.0	0.8	1.2	0.35	1.71	0.94	0.171	0.081	
2580	2520	16.0	38.5	37.5	57.0	62.5	0.8	3.2	0.27	2.19	1.21	0.281	0.123	
02475	02420	17.1	44.5	38.5	59.0	63.0	3.6	1.6	0.42	1.44	0.79	0.224	0.150	
02476	02420	17.1	39.0	38.5	59.0	63.0	0.8	1.6	0.42	1.44	0.79	0.226	0.150	
M88046	M88010	19.2	43.0	40.5	58.0	65.0	1.6	1.6	0.55	1.10	0.60	0.245	0.144	
02875	02820	17.1	45.5	39.5	62.0	68.0	3.6	3.2	0.45	1.32	0.73	0.293	0.158	
02876	02820	17.1	40.0	39.5	62.0	68.0	0.8	3.2	0.45	1.32	0.73	0.293	0.158	
HM88542	HM88510	23.4	45.5	42.5	59.0	70.0	1.2	3.2	0.55	1.10	0.60	0.377	0.238	
HM88542	HM88512	23.4	45.5	42.5	59.0	70.0	1.2	3.2	0.55	1.10	0.60	0.377	0.254	
M88048	M88010	19.2	42.5	41.0	58.0	65.0	0.8	1.6	0.55	1.10	0.60	0.231	0.144	
26131	26283	15.3	44.5	38.5	62.0	65.0	3.6	1.6	0.36	1.67	0.92	0.200	0.163	
HM88547	HM88510	23.4	45.5	42.6	59.0	70.0	0.8	3.2	0.55	1.10	0.60	0.360	0.238	
HM89443	HM89410	23.9	46.5	44.6	62.0	73.0	0.8	3.2	0.55	1.10	0.60	0.415	0.254	
LM48548	LM48510	14.3	46.0	40.0	58.0	61.0	3.5	1.2	0.38	1.59	0.88	0.164	0.086	
14136A	14276	22.6	40.0	38.0	60.0	63.0	0.8	1.2	0.38	1.57	0.86	0.254	0.133	
HM88649	HM88610	20.7	48.5	42.5	60.0	69.0	2.4	2.4	0.55	1.10	0.60	0.301	0.185	

[Remark] Inch series tapered roller bearings with bore diameter larger than 100 mm are shown in catalog "large size ball & roller bearings".

Single-row tapered roller bearings inch series

d (34.925) ~ (38.100) mm

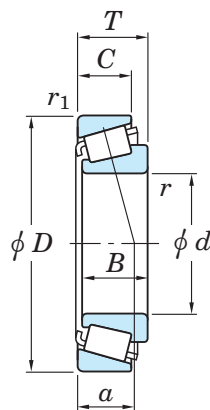

d	Boundary dimensions (mm)					Basic load ratings (kN)		Limiting speeds (min ⁻¹)		
	D	T	B	C	$r_1^{1)}$ min.	$r_1^{1)}$ min.	C_r	C_{0r}	Grease lub.	Oil lub.
34.925	72.238	20.638	20.638	15.875	3.6	1.2	49.7	61.3	5 600	7 400
	73.025	22.225	22.225	17.462	3.6	3.2	55.0	65.7	5 500	7 400
	73.025	22.225	22.225	17.462	0.8	3.2	55.0	65.7	5 500	7 400
	73.025	23.812	24.608	19.050	1.6	0.8	72.2	87.3	5 600	7 400
	73.025	26.988	26.975	22.225	3.6	1.6	77.8	94.1	5 700	7 600
	76.200	20.638	20.940	15.507	1.6	1.2	57.3	65.9	5 300	7 000
	76.200	23.812	25.654	19.050	3.6	3.2	74.1	92.2	5 400	7 200
	76.200	29.370	28.575	23.812	1.6	3.2	80.9	97.4	5 400	7 200
	79.375	29.370	29.771	23.812	3.6	3.2	87.4	105	5 200	6 900
	87.312	30.162	30.886	23.812	3.6	3.2	95.8	120	4 600	6 200
95.250	27.783	29.901	22.225	0.8	2.4	103	122	4 500	5 900	
34.980	59.131	15.875	16.764	11.938	SP	1.2	35.7	48.5	6 400	8 500
	59.975	15.875	16.764	11.938	SP	1.2	35.7	48.5	6 400	8 500
35.000	79.375	23.812	25.400	19.050	0.8	0.8	81.1	105	5 000	6 700
	80.000	21.000	22.403	17.826	0.8	1.2	68.0	74.8	4 900	6 600
35.717	72.233	25.400	25.400	19.842	3.6	2.4	66.9	87.4	5 700	7 600
36.487	73.025	23.812	24.608	19.050	1.6	0.8	72.2	87.3	5 600	7 400
	73.025	23.812	25.654	19.050	3.6	0.8	74.1	92.2	5 400	7 200
36.512	76.200	29.370	28.575	23.020	3.6	0.8	79.5	107	5 400	7 200
	79.375	23.812	25.400	19.050	0.8	0.8	81.1	105	5 000	6 700
	79.375	29.370	29.771	23.812	0.8	3.2	87.4	105	5 200	6 900
	85.725	30.162	30.162	23.812	0.8	3.2	108	136	4 800	6 400
38.000	63.000	17.000	17.000	13.500	SP	SP	43.5	58.2	6 000	8 000
38.100	63.500	12.700	11.908	9.525	1.6	0.8	25.5	33.1	5 800	7 700

[Notes] 1) SP indicates the specially chamfered from.

2) To the bearings with supplementary code "J" attached at the front of bearing number, tolerances shown in table 7-8 on page A66 are applied.

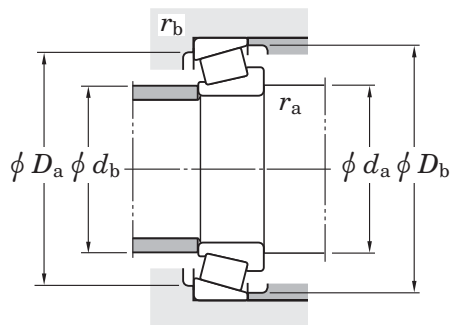

	Bearing No. ²⁾		Load center (mm) a	Mounting dimensions (mm)						Constant e	Axial load factors		(Refer.) Mass (kg)	
	Inner ring	Outer ring		d_a	d_b	D_a	D_b	r_a max.	r_b max.		Y_1	Y_0	Inner ring	Outer ring
	16137	16284	16.6	46.5	40.5	63.0	67.0	3.6	1.2	0.40	1.49	0.82	0.236	0.144
	02877	02820	18.4	48.5	42.0	62.0	68.0	3.6	3.2	0.45	1.32	0.73	0.262	0.158
	02878	02820	18.4	42.5	42.0	62.0	68.0	0.8	3.2	0.45	1.32	0.73	0.265	0.158
	25877R	25821	15.8	43.0	40.5	65.0	68.0	1.6	0.8	0.29	2.07	1.14	0.310	0.165
	23690	23620	18.8	49.0	42.0	64.0	68.0	3.6	1.6	0.37	1.62	0.89	0.326	0.212
	28137	28300	16.5	43.5	41.0	68.0	71.0	1.6	1.2	0.40	1.49	0.82	0.315	0.137
	2796R	2720	15.9	47.5	41.0	66.0	70.0	3.6	3.2	0.30	1.98	1.09	0.344	0.185
	31594	31520	21.6	46.0	43.5	64.0	72.0	1.6	3.2	0.40	1.49	0.82	0.388	0.232
	3478	3420	20.8	50.0	43.5	67.0	74.0	3.6	3.2	0.37	1.64	0.90	0.462	0.256
	3581R	3525	20.5	48.0	45.5	75.0	81.0	3.6	3.2	0.31	1.96	1.08	0.622	0.300
	449	432	18.4	44.0	43.5	83.0	87.0	0.8	2.4	0.28	2.11	1.16	0.686	0.384
	L68149	L68110	13.2	45.5	39.0	53.0	56.0	3.5	1.2	0.42	1.44	0.79	0.112	0.056
	L68149	L68111	13.2	45.5	39.0	53.0	56.0	3.5	1.2	0.42	1.44	0.79	0.112	0.063
	26883R	26822	16.4	42.5	42.0	71.0	74.0	0.8	0.8	0.32	1.88	1.04	0.414	0.186
	339	332	15.1	42.5	41.5	73.0	75.0	0.8	1.2	0.27	2.20	1.21	0.385	0.144
	HM88648	HM88610	20.7	52.0	42.5	60.0	69.0	3.6	2.4	0.55	1.10	0.60	0.291	0.185
	25880R	25821	15.8	44.0	42.0	65.0	68.0	1.6	0.8	0.29	2.07	1.14	0.294	0.165
	2794R	2735X	15.9	49.0	42.5	66.0	69.0	3.6	0.8	0.30	1.98	1.09	0.344	0.134
	HM89449	HM89411	23.9	54.0	44.5	65.0	73.0	3.6	0.8	0.55	1.10	0.60	0.386	0.258
	26877R	26822	16.4	44.0	43.0	71.0	74.0	0.8	0.8	0.32	1.88	1.04	0.404	0.186
	3479	3420	20.8	45.5	44.5	67.0	74.0	0.8	3.2	0.37	1.64	0.90	0.429	0.259
	3878	3820	22.9	48.0	47.0	73.0	81.0	0.8	3.2	0.40	1.49	0.82	0.605	0.285
	JL69349	JL69310	14.6	49.0	41.0	60.0	56.5	3.5	1.2	0.42	1.44	0.79	0.128	0.070
	13889	13830	11.9	45.0	42.5	59.0	60.0	1.6	0.8	0.35	1.73	0.95	0.104	0.045

[Remark] Inch series tapered roller bearings with bore diameter larger than 100 mm are shown in catalog "large size ball & roller bearings".

Single-row tapered roller bearings inch series

d (38.100) ~ (40.000) mm

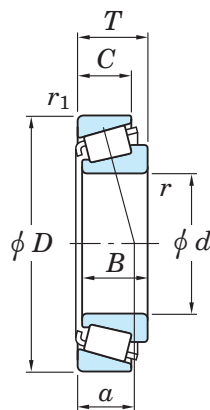

d	Boundary dimensions (mm)						Basic load ratings (kN)		Limiting speeds (min ⁻¹)	
	D	T	B	C	$r^{1)}$ min.	r_1 min.	C_r	C_{0r}	Grease lub.	Oil lub.
38.100	65.088	12.700	11.908	9.525	1.6	0.8	25.5	33.1	5 800	7 700
	65.088	18.034	18.288	13.970	SP	1.2	42.9	56.5	5 800	7 800
	65.088	19.812	18.288	15.748	2.4	1.2	42.9	56.5	5 800	7 800
	69.012	19.050	19.050	15.083	2.0	2.4	49.2	62.0	5 600	7 500
	71.438	15.875	16.520	11.908	1.6	1.0	46.1	53.8	5 700	7 600
	71.996	17.018	16.520	14.288	1.6	1.6	46.1	53.8	5 700	7 600
	71.996	19.000	20.638	14.237	3.6	1.6	49.7	61.3	5 600	7 400
	72.238	20.638	20.638	15.875	3.6	1.2	49.7	61.3	5 600	7 400
	72.238	23.812	20.638	19.050	3.6	2.4	49.7	61.3	5 600	7 400
	73.025	23.812	25.654	19.050	3.6	0.8	74.1	92.2	5 400	7 200
	76.200	23.812	25.654	19.050	3.6	0.8	74.1	92.2	5 400	7 200
	79.375	29.370	29.771	23.812	3.6	3.2	87.4	105	5 200	6 900
	80.035	21.432	20.940	15.875	1.6	1.6	57.3	65.9	5 300	7 000
	80.035	24.608	23.698	18.512	0.8	1.6	73.2	91.6	5 200	6 900
	80.035	24.608	23.698	18.512	3.6	1.6	73.2	91.6	5 200	6 900
	82.550	29.370	28.575	23.020	0.8	3.2	87.3	117	4 900	6 600
	82.550	29.370	28.575	23.020	2.4	3.2	87.3	117	4 900	6 600
	82.931	23.812	25.400	19.050	0.8	0.8	77.2	100	4 800	6 300
	88.501	26.988	29.083	22.225	3.6	1.6	98.2	112	4 900	6 500
	90.488	39.688	40.386	33.338	1.6	3.2	132	169	4 500	6 000
101.600	34.925	36.068	26.988	3.6	3.2	131	159	4 000	5 300	
39.688	73.025	16.667	17.462	12.700	0.8	1.6	45.9	55.8	5 200	6 900
	73.025	23.812	25.654	19.050	3.6	0.8	74.1	92.2	5 400	7 200
	80.167	29.370	30.391	23.812	0.8	3.2	91.0	106	5 000	6 700
	84.138	29.370	30.391	23.812	3.6	3.2	91.0	106	5 000	6 700
40.000	76.200	20.638	20.940	15.507	1.6	1.2	57.3	65.9	5 300	7 000
	80.000	21.000	22.403	17.826	3.6	1.2	68.0	74.8	4 900	6 600

[Note] 1) SP indicates the specially chamfered from.

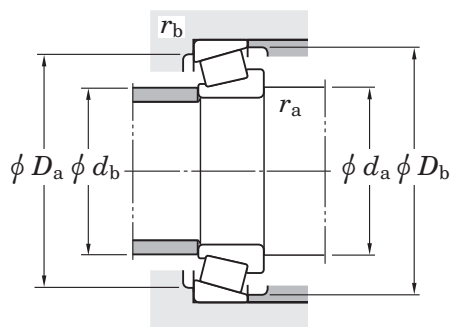

	Bearing No.		Load center (mm) <i>a</i>	Mounting dimensions (mm)						Constant <i>e</i>	Axial load factors		(Refer.) Mass (kg)	
	Inner ring	Outer ring		<i>d_a</i>	<i>d_b</i>	<i>D_a</i>	<i>D_b</i>	<i>r_a</i> max.	<i>r_b</i> max.		<i>Y₁</i>	<i>Y₀</i>	Inner ring	Outer ring
	13889	13836	11.9	45.0	42.5	59.0	61.0	1.6	0.8	0.35	1.73	0.95	0.104	0.046
	LM29748	LM29710	13.8	49.0	42.5	59.0	62.0	3.5	1.2	0.33	1.80	0.99	0.154	0.079
	LM29749	LM29711	15.6	46.0	42.5	58.0	62.0	2.4	1.2	0.33	1.80	0.99	0.159	0.092
	13687	13621	16.1	46.5	43.0	61.0	65.0	2.0	2.4	0.40	1.49	0.82	0.191	0.102
	19150R	19281	14.5	45.0	43.0	63.0	66.0	1.6	1.0	0.44	1.35	0.74	0.167	0.105
	19150R	19283	15.7	45.0	43.0	63.0	66.0	1.6	1.6	0.44	1.35	0.74	0.167	0.132
	16150	16282	15.0	49.5	43.0	63.0	67.0	3.6	1.6	0.40	1.49	0.82	0.207	0.121
	16150	16284	16.6	49.5	43.0	63.0	67.0	3.6	1.2	0.40	1.49	0.82	0.207	0.144
	16150	16283	19.8	49.5	43.0	61.0	67.0	3.6	2.4	0.40	1.49	0.82	0.207	0.183
	2788R	2735X	15.9	50.0	43.5	66.0	69.0	3.6	0.8	0.30	1.98	1.09	0.308	0.134
	2788R	2729	15.9	50.0	43.5	68.0	70.0	3.6	0.8	0.30	1.98	1.09	0.308	0.189
	3490	3420	20.8	52.0	45.9	67.0	74.0	3.6	3.2	0.37	1.64	0.90	0.419	0.256
	28150	28317	16.9	45.5	43.5	69.0	73.0	1.6	1.6	0.40	1.49	0.82	0.285	0.201
	27880	27820	22.2	48.0	47.0	68.0	75.0	0.8	1.6	0.56	1.07	0.59	0.378	0.208
	27881	27820	22.2	53.0	47.0	68.0	75.0	3.6	1.6	0.56	1.07	0.59	0.378	0.208
	HM801346	HM801310	24.4	51.0	49.0	68.0	78.0	0.8	3.2	0.55	1.10	0.60	0.483	0.282
	HM801346X	HM801310	24.4	54.0	49.0	68.0	78.0	2.4	3.2	0.55	1.10	0.60	0.483	0.282
	25572	25520	17.5	46.0	46.0	74.0	77.0	0.8	0.8	0.33	1.79	0.99	0.437	0.203
	418	414	16.9	51.0	44.5	77.0	80.0	3.6	1.6	0.26	2.28	1.25	0.523	0.325
	4375	4335	25.6	51.0	48.5	77.0	85.0	1.6	3.2	0.28	2.11	1.16	0.841	0.459
	525	522	22.2	54.0	48.0	89.0	95.0	3.6	3.2	0.29	2.10	1.16	1.05	0.411
	18587	18520	14.5	46.0	46.0	66.0	69.0	0.8	1.6	0.35	1.71	0.94	0.215	0.085
	2789R	2735X	15.9	52.0	45.0	66.0	69.0	3.6	0.8	0.30	1.98	1.09	0.288	0.134
	3386	3320	18.7	46.5	45.5	70.0	75.0	0.8	3.2	0.27	2.20	1.21	0.442	0.217
	3382	3328	18.7	52.0	45.5	72.0	76.0	3.6	3.2	0.27	2.20	1.21	0.438	0.312
	28158	28300	16.5	47.5	45.0	68.0	71.0	1.6	1.2	0.40	1.49	0.82	0.266	0.137
	344	332	15.1	52.0	45.5	73.0	75.0	3.6	1.2	0.27	2.20	1.21	0.334	0.144

[Remark] Inch series tapered roller bearings with bore diameter larger than 100 mm are shown in catalog "large size ball & roller bearings".

Single-row tapered roller bearings inch series

d (40.000) ~ 42.070 mm

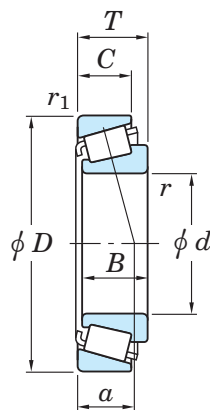

d	Boundary dimensions (mm)						Basic load ratings (kN)		Limiting speeds (min ⁻¹)	
	D	T	B	C	r min.	r_1 min.	C_r	C_{0r}	Grease lub.	Oil lub.
40.000	80.000	21.000	22.403	17.826	0.8	1.2	68.0	74.8	4 900	6 600
	85.000	20.638	21.692	17.462	0.8	1.2	71.8	81.7	4 600	6 200
	88.501	26.988	29.083	22.225	3.6	1.6	98.2	112	4 900	6 500
	107.950	36.512	36.957	28.575	3.6	3.2	138	172	3 800	5 100
40.483	82.550	29.370	28.575	23.020	3.6	3.2	87.3	117	4 900	6 600
41.275	73.025	16.667	17.462	12.700	3.6	1.6	45.9	55.8	5 200	6 900
	73.431	19.558	19.812	14.732	3.6	0.8	57.8	73.0	5 200	7 000
	73.431	21.430	19.812	16.604	3.6	0.8	57.8	73.0	5 200	7 000
	73.431	23.012	19.812	18.186	3.6	2.4	57.8	73.0	5 200	7 000
	76.200	18.009	17.384	14.288	1.6	1.6	51.6	63.3	5 200	6 900
	76.200	22.225	23.020	17.462	3.6	0.8	66.3	83.3	5 200	6 900
	80.000	21.000	22.403	17.826	0.8	1.2	68.0	74.8	4 900	6 600
	80.000	21.000	22.403	17.826	3.6	1.2	68.0	74.8	4 900	6 600
	82.550	26.543	25.654	20.193	3.6	3.2	83.7	105	4 900	6 500
	85.725	30.162	30.162	23.812	3.6	1.2	108	136	4 800	6 400
	87.312	30.162	30.886	23.812	0.8	3.2	95.8	120	4 600	6 200
	88.501	26.988	29.083	22.225	3.6	1.6	98.2	112	4 900	6 500
	88.900	20.638	22.225	16.513	3.6	1.2	74.3	87.3	4 400	5 800
	88.900	30.162	29.370	23.020	0.8	3.2	99.6	125	4 600	6 100
	88.900	30.162	29.370	23.020	3.6	3.2	99.6	125	4 600	6 100
	90.488	39.688	40.386	33.338	3.6	3.2	132	169	4 500	6 000
	93.662	31.750	31.750	26.195	0.8	3.2	105	134	4 400	5 800
	95.250	30.162	29.370	23.020	3.6	3.2	104	140	3 300	4 400
101.600	34.925	36.068	26.988	3.6	3.2	131	159	4 000	5 300	
104.775	36.512	36.512	28.575	1.6	3.2	141	195	3 800	5 100	
42.070	90.488	39.688	40.386	33.338	3.6	3.2	132	169	4 500	6 000

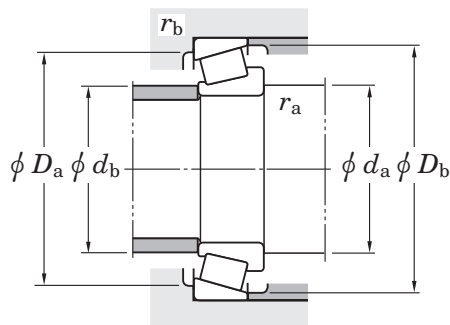

	Bearing No.		Load center (mm) a	Mounting dimensions (mm)						Constant e	Axial load factors		(Refer.) Mass (kg)	
	Inner ring	Outer ring		d_a	d_b	D_a	D_b	r_a max.	r_b max.		Y_1	Y_0	Inner ring	Outer ring
	344A	332	15.1	46.0	45.5	73.0	75.0	0.8	1.2	0.27	2.20	1.21	0.334	0.144
	350A	354A	15.5	47.5	46.5	77.0	80.0	0.8	1.2	0.31	1.96	1.08	0.416	0.162
	420	414	16.9	52.0	46.0	77.0	80.0	3.6	1.6	0.26	2.28	1.25	0.465	0.325
	543	532X	23.9	57.0	50.0	94.0	100.0	3.6	3.2	0.30	2.03	1.11	1.17	0.570
	HM801349	HM801310	24.4	58.0	49.0	68.0	78.0	3.6	3.2	0.55	1.10	0.60	0.450	0.282
	18590	18520	14.5	53.0	46.0	66.0	69.0	3.6	1.6	0.35	1.71	0.94	0.199	0.085
	LM501349	LM501310	16.1	53.0	46.5	67.0	70.0	3.6	0.8	0.40	1.50	0.83	0.227	0.107
	LM501349	LM501314	18.0	53.0	46.5	66.0	70.0	3.6	0.8	0.40	1.50	0.83	0.227	0.126
	LM501349	LM501311	16.1	53.0	46.5	64.0	70.0	3.6	2.4	0.40	1.50	0.83	0.227	0.140
	11162R	11300	17.5	49.0	46.5	67.0	72.0	1.6	1.6	0.49	1.23	0.68	0.221	0.127
	24780R	24720	17.4	54.0	47.0	68.0	72.0	3.6	0.8	0.39	1.53	0.84	0.275	0.148
	336	332	15.1	47.0	46.0	73.0	75.0	0.8	1.2	0.27	2.20	1.21	0.325	0.144
	342	332	15.1	53.0	46.0	73.0	75.0	3.6	1.2	0.27	2.20	1.21	0.317	0.144
	M802048	M802011	23.3	57.0	50.6	70.0	79.0	3.6	3.2	0.55	1.10	0.60	0.403	0.227
	3877	3821	22.9	57.0	50.3	75.0	81.0	3.6	1.2	0.40	1.49	0.82	0.506	0.324
	3576R	3525	20.5	49.0	48.0	75.0	81.0	0.8	3.2	0.31	1.96	1.08	0.533	0.300
	419	414	16.9	54.0	47.0	77.0	80.0	3.6	1.6	0.26	2.28	1.25	0.441	0.325
	365A	362A	16.1	55.0	48.5	81.0	84.0	3.6	1.2	0.32	1.88	1.03	0.458	0.164
	HM803145	HM803110	26.1	54.0	53.0	74.0	85.0	0.8	3.2	0.55	1.10	0.60	0.577	0.318
	HM803146	HM803110	26.1	60.0	53.0	74.0	85.0	3.6	3.2	0.55	1.10	0.60	0.574	0.318
	4388	4335	25.6	57.0	51.0	77.0	85.0	3.6	3.2	0.28	2.11	1.16	0.775	0.454
	46162	46368	24.0	52.0	51.0	79.0	87.0	0.8	3.2	0.40	1.49	0.82	0.695	0.403
	HM804840	HM804810	26.5	61.0	54.0	81.0	91.0	3.6	3.2	0.55	1.10	0.60	0.719	0.351
	526	522	22.2	57.0	50.0	89.0	95.0	3.6	3.2	0.29	2.10	1.16	1.02	0.411
	HM807035	HM807010	29.3	60.0	57.0	89.0	100.0	1.6	3.2	0.49	1.23	0.68	1.19	0.497
	4395	4335	25.6	58.0	51.0	77.0	85.0	3.6	3.2	0.28	2.11	1.16	0.751	0.459

[Remark] Inch series tapered roller bearings with bore diameter larger than 100 mm are shown in catalog "large size ball & roller bearings".

Single-row tapered roller bearings inch series

d 42.862 ~ 45.000 mm

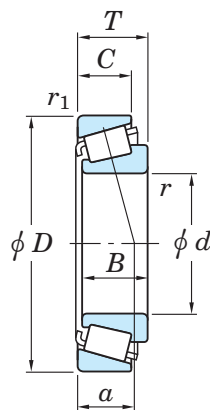

d	Boundary dimensions (mm)						Basic load ratings (kN)		Limiting speeds (min ⁻¹)	
	D	T	B	C	r min.	r_1 min.	C_r	C_{0r}	Grease lub.	Oil lub.
42.862	76.992	17.463	17.145	11.908	1.6	1.6	48.4	62.2	5 000	6 600
42.875	79.375	23.812	25.400	19.050	3.6	0.8	81.1	105	5 000	6 700
	82.931	23.812	25.400	19.050	3.6	0.8	77.2	100	4 800	6 300
44.450	73.025	18.258	18.258	15.083	1.6	1.6	47.2	65.5	5 100	6 800
	76.992	17.463	17.145	11.908	1.6	1.6	48.4	62.2	5 000	6 600
	79.375	17.462	17.462	13.495	2.8	1.6	47.1	59.1	4 800	6 400
	82.931	23.812	25.400	19.050	5.2	0.8	77.2	100	4 800	6 300
	84.138	30.162	30.886	23.812	3.6	3.2	95.8	120	4 600	6 200
	85.000	20.638	21.692	17.462	2.4	1.2	71.8	81.7	4 600	6 200
	85.000	20.638	21.692	17.462	0.8	1.2	71.8	81.7	4 600	6 200
	88.900	30.162	29.370	23.020	3.6	3.2	99.6	125	4 600	6 100
	93.662	31.750	31.750	25.400	3.6	3.2	105	123	4 400	5 900
	93.662	31.750	31.750	26.195	0.8	3.2	105	134	4 400	5 800
	93.662	31.750	31.750	26.195	3.6	3.2	105	134	4 400	5 800
	95.250	27.783	28.575	22.225	0.8	2.4	108	141	4 100	5 400
	95.250	27.783	29.901	22.225	3.6	0.8	103	122	4 500	5 900
	95.250	30.162	29.370	23.020	0.8	2.4	104	140	3 300	4 400
	95.250	30.162	29.370	23.020	3.6	2.4	104	140	3 300	4 400
	98.425	30.162	31.750	25.400	0.8	3.2	114	143	3 900	5 200
101.600	34.925	36.068	26.988	3.6	3.2	131	159	4 000	5 300	
104.775	36.512	36.512	28.575	3.6	3.2	141	195	3 800	5 100	
111.125	38.100	36.957	30.162	3.6	3.2	138	172	3 800	5 100	
120.650	41.275	41.275	31.750	3.6	3.2	174	217	3 500	4 600	
44.983	93.264	30.162	30.302	23.812	3.6	3.2	103	137	4 200	5 500
45.000	85.000	20.638	21.692	17.462	1.6	1.2	71.8	81.7	4 600	6 200

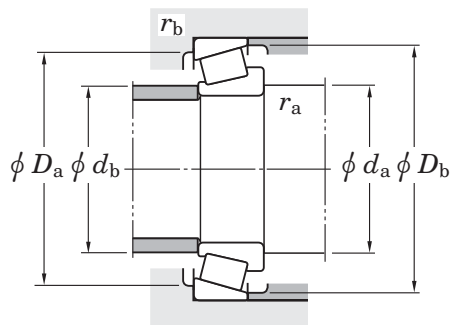

Bearing No.	Load center (mm) a	Mounting dimensions (mm)								Constant e	Axial load factors		(Refer.) Mass (kg)	
		Inner ring	Outer ring	d_a	d_b	D_a	D_b	r_a max.	r_b max.		Y_1	Y_0	Inner ring	Outer ring
12168 12303	17.5			51.0	48.5	68.0	73.0	1.6	1.6	0.51	1.19	0.65	0.220	0.097
26884R 26822	16.1			55.0	48.5	71.0	74.0	3.6	0.8	0.32	1.88	1.04	0.314	0.186
25577 25520	17.5			55.0	49.0	74.0	77.0	3.6	0.8	0.33	1.79	0.99	0.382	0.200
L102849 L102810	14.6			51.0	49.0	66.0	69.0	1.6	1.6	0.32	1.88	1.04	0.183	0.102
12175 12303	17.5			52.0	49.5	68.0	73.0	1.6	1.6	0.51	1.19	0.65	0.206	0.097
18685 18620	16.0			54.0	49.5	71.0	74.0	2.8	1.6	0.37	1.60	0.88	0.214	0.126
25582 25520	17.5			59.0	51.0	74.0	77.0	5.2	0.8	0.33	1.79	0.99	0.361	0.200
3578R 3520	20.5			57.0	51.0	74.0	79.5	3.6	3.2	0.31	1.96	1.08	0.479	0.221
355 354A	15.5			54.0	50.0	77.0	80.0	2.4	1.2	0.31	1.96	1.08	0.344	0.160
355A 354A	15.5			51.0	50.0	77.0	80.0	0.8	1.2	0.31	1.96	1.08	0.344	0.160
HM803149 HM803110	26.1			62.0	53.4	74.0	85.0	3.6	3.2	0.55	1.10	0.60	0.525	0.318
49175 49368	22.9			59.0	53.0	82.0	87.0	3.6	3.2	0.36	1.67	0.92	0.645	0.371
46175 46368	24.0			55.0	54.0	79.0	87.0	0.8	3.2	0.40	1.49	0.82	0.609	0.403
46176 46368	24.0			60.0	54.0	79.0	87.0	3.6	3.2	0.40	1.49	0.82	0.609	0.403
33885 33821	20.4			53.0	53.0	85.0	90.0	0.8	2.4	0.33	1.82	1.00	0.714	0.264
438 432A	18.4			57.0	51.0	84.0	87.0	3.6	0.8	0.28	2.11	1.16	0.555	0.375
HM804842 HM804810	26.5			57.0	57.0	81.0	91.0	0.8	2.4	0.55	1.10	0.60	0.673	0.351
HM804843 HM804810	26.5			63.0	57.0	81.0	91.0	3.6	2.4	0.55	1.10	0.60	0.670	0.351
49576 49520	24.1			55.0	54.0	88.0	96.0	0.8	3.2	0.40	1.50	0.82	0.856	0.384
527 522	22.2			59.0	53.0	89.0	95.0	3.6	3.2	0.29	2.10	1.16	0.939	0.411
HM807040 HM807010	29.3			66.0	59.0	89.0	100.0	3.6	3.2	0.49	1.23	0.68	1.13	0.497
535 532A	23.9			60.0	54.0	95.0	100.0	3.6	3.2	0.30	2.03	1.11	1.09	0.746
615 612	27.3			62.0	56.0	105.0	110.0	3.6	3.2	0.31	1.91	1.05	1.48	0.853
3776 3720	22.2			59.0	53.0	82.0	88.0	3.6	3.2	0.34	1.77	0.97	0.650	0.288
358 354A	15.5			52.5	50.0	77.0	80.0	1.6	1.2	0.31	1.96	1.08	0.338	0.162

[Remark] Inch series tapered roller bearings with bore diameter larger than 100 mm are shown in catalog "large size ball & roller bearings".

Single-row tapered roller bearings inch series

d 45.242 ~ 49.212 mm

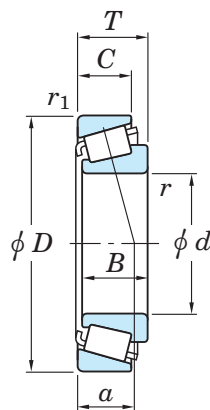

d	Boundary dimensions (mm)						Basic load ratings (kN)		Limiting speeds (min ⁻¹)	
	D	T	B	C	r min.	r_1 min.	C_r	C_{0r}	Grease lub.	Oil lub.
45.242	73.431	19.558	19.812	15.748	3.6	0.8	55.6	78.1	5 100	6 700
	77.788	19.842	19.842	15.080	3.6	0.8	57.1	73.5	4 900	6 500
	77.788	21.430	19.842	16.667	3.6	0.8	57.1	73.5	4 900	6 500
	79.974	19.842	19.842	15.080	3.6	0.8	57.1	73.5	4 900	6 500
45.618	85.000	23.812	25.400	19.050	3.6	2.4	77.2	100	4 800	6 300
45.987	74.976	18.000	18.000	14.000	2.4	1.6	52.6	74.6	5 000	6 600
46.038	79.375	17.462	17.462	13.495	2.8	1.6	47.1	59.1	4 800	6 400
	85.000	20.638	21.692	17.462	3.6	1.2	71.8	81.7	4 600	6 200
	85.000	20.638	21.692	17.462	2.4	1.2	71.8	81.7	4 600	6 200
	85.000	25.400	25.608	20.638	3.6	1.2	80.0	106	4 600	6 100
47.625	88.900	20.638	22.225	16.513	3.6	1.2	74.3	87.3	4 400	5 800
	88.900	25.400	25.400	19.050	3.6	3.2	87.1	112	4 400	5 900
	95.250	30.162	29.370	23.020	3.6	3.2	104	140	3 300	4 400
	96.838	21.000	21.946	15.875	0.8	0.8	80.4	101	3 900	5 200
	101.600	34.925	36.068	26.988	3.6	3.2	131	159	4 000	5 300
	104.775	30.162	29.317	24.605	4.8	3.2	109	144	3 700	4 900
	104.775	30.162	29.317	24.605	0.8	3.2	109	144	3 700	4 900
104.775	30.162	30.958	23.812	3.6	3.2	126	165	3 700	4 900	
48.412	95.250	30.162	29.370	23.020	2.4	3.2	104	140	3 300	4 400
	95.250	30.162	29.370	23.020	3.6	3.2	104	140	3 300	4 400
49.212	88.900	20.638	22.225	16.513	0.8	1.2	74.3	87.3	4 400	5 800
	104.775	36.512	36.512	28.575	3.6	3.2	141	195	3 800	5 100
	114.300	44.450	44.450	34.925	3.6	3.2	189	230	3 800	5 000
	114.300	44.450	44.450	36.068	3.6	3.2	212	263	3 700	5 000

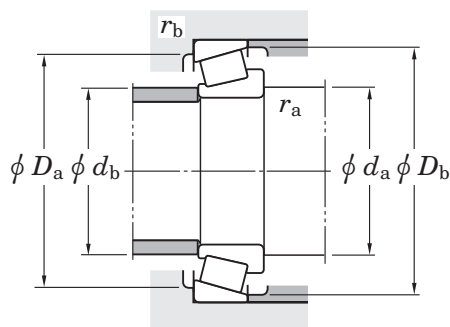

Bearing No.	Load center (mm) a	Mounting dimensions (mm)								Constant e	Axial load factors		(Refer.) Mass (kg)	
		Inner ring	Outer ring	d_a	d_b	D_a	D_b	r_a max.	r_b max.		Y_1	Y_0	Inner ring	Outer ring
LM102949 LM102910	14.7			56.0	50.0	68.0	70.0	3.6	0.8	0.31	1.97	1.08	0.209	0.100
LM603049 LM603011	17.5			57.0	50.0	71.0	74.0	3.6	0.8	0.43	1.41	0.77	0.243	0.120
LM603049 LM603012	19.1			57.0	50.0	71.0	74.0	3.6	0.8	0.43	1.41	0.77	0.243	0.138
LM603049 LM603014	17.5			57.0	50.0	71.0	74.0	3.6	0.8	0.43	1.41	0.77	0.243	0.152
25590 25526	17.5			58.0	51.0	74.0	78.0	3.6	2.4	0.33	1.79	0.99	0.344	0.241
LM503349R LM503310	16.0			53.0	51.0	67.0	72.0	2.4	1.6	0.40	1.49	0.82	0.207	0.095
18690 18620	16.0			56.0	51.0	71.0	74.0	2.8	1.6	0.37	1.60	0.88	0.208	0.123
359A 354A	15.5			57.0	51.0	77.0	80.0	3.6	1.2	0.31	1.96	1.08	0.323	0.160
359S 354A	15.5			55.0	51.0	77.0	80.0	2.4	1.2	0.31	1.96	1.08	0.323	0.160
2984 2924	18.9			58.0	52.0	76.0	80.0	3.6	1.2	0.35	1.73	0.95	0.389	0.220
369A 362A	16.1			60.0	53.0	81.0	84.0	3.6	1.2	0.32	1.88	1.03	0.373	0.164
M804049 M804010	23.6			62.0	55.0	76.0	85.0	3.6	3.2	0.55	1.10	0.60	0.450	0.216
HM804846 HM804810	26.5			64.0	57.0	81.0	91.0	3.6	3.2	0.55	1.10	0.60	0.617	0.351
386A 382A	17.4			56.0	55.0	89.0	92.0	0.8	0.8	0.35	1.69	0.93	0.563	0.177
528 522	22.2			62.0	55.0	89.0	95.0	3.6	3.2	0.29	2.10	1.16	0.871	0.411
463 453X	23.6			65.0	56.0	92.0	98.0	4.8	3.2	0.34	1.79	0.98	0.838	0.372
467 453X	23.6			57.0	56.0	92.0	98.0	0.8	3.2	0.34	1.79	0.98	0.844	0.372
45282 45220	22.2			64.0	59.0	93.0	99.0	3.6	3.2	0.33	1.80	0.99	0.940	0.345
HM804848 HM804810	26.5			63.0	57.5	81.0	91.0	2.4	3.2	0.55	1.10	0.60	0.606	0.351
HM804849 HM804810	26.5			66.0	57.5	81.0	91.0	3.6	3.2	0.55	1.10	0.60	0.604	0.351
365S 362A	16.1			55.0	54.0	81.0	84.0	0.8	1.2	0.32	1.88	1.03	0.366	0.164
HM807044 HM807010	29.3			69.0	63.0	89.0	100.0	3.6	3.2	0.49	1.23	0.68	1.03	0.497
65390 65320	31.7			70.0	60.0	97.0	107.0	3.6	3.2	0.43	1.40	0.77	1.28	0.894
HH506348 HH506310	30.6			71.0	61.0	97.0	107.0	3.6	3.2	0.40	1.49	0.82	1.49	0.834

[Remark] Inch series tapered roller bearings with bore diameter larger than 100 mm are shown in catalog "large size ball & roller bearings".

Single-row tapered roller bearings inch series

d 49.987 ~ (50.800) mm

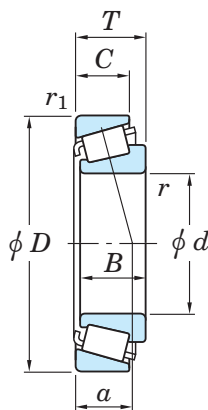

d	Boundary dimensions (mm)						Basic load ratings (kN)		Limiting speeds (min ⁻¹)	
	D	T	B	C	r min.	r_1 min.	C_r	C_{0r}	Grease lub.	Oil lub.
49.987	92.075	24.608	25.400	19.845	2.4	0.8	84.8	119	4 200	5 600
50.000	82.000	21.501	21.501	17.000	3.0	0.5	71.7	97.9	4 500	6 000
	88.900	20.638	22.225	16.513	2.0	1.2	74.3	87.3	4 400	5 800
	88.900	20.638	22.225	16.513	2.4	1.2	74.3	87.3	4 400	5 800
	90.000	28.000	28.000	23.000	3.0	2.5	105	138	4 300	5 800
	105.000	37.000	36.000	29.000	3.0	2.8	149	205	3 800	5 100
	110.000	22.000	21.996	18.824	0.8	1.2	86.4	116	3 400	4 500
50.800	80.962	18.258	18.258	14.288	1.6	1.6	54.0	81.1	4 600	6 100
	82.550	21.590	22.225	16.510	3.6	1.2	61.2	84.3	4 500	6 000
	85.725	19.050	18.263	12.700	1.6	1.6	50.7	66.4	4 400	5 900
	88.900	17.462	17.462	13.495	3.6	1.2	49.7	65.5	4 400	5 900
	88.900	20.638	22.225	16.513	1.6	1.2	74.3	87.3	4 400	5 800
	88.900	20.638	22.225	16.513	3.6	1.2	74.3	87.3	4 400	5 800
	88.900	20.638	22.225	16.513	5.2	1.2	74.3	87.3	4 400	5 800
	92.075	24.608	25.400	19.845	3.6	0.8	84.8	119	4 200	5 600
	93.264	20.638	22.225	15.083	2.4	1.2	84.4	98.5	4 200	5 600
	93.264	30.162	30.302	23.812	3.6	3.2	103	137	4 200	5 500
	93.264	30.162	30.302	23.812	3.6	0.8	103	137	4 200	5 500
	95.250	27.783	28.575	22.225	3.6	0.8	108	141	4 100	5 400
	96.838	21.000	21.946	15.875	0.8	0.8	80.4	101	3 900	5 200
	97.630	24.608	24.608	19.446	3.6	0.8	89.6	131	3 900	5 200
	98.425	30.162	30.302	23.812	3.6	3.2	103	137	4 200	5 500
	101.600	31.750	31.750	25.400	3.6	3.2	114	143	3 900	5 200
	101.600	34.925	36.068	26.988	0.8	3.2	131	159	4 000	5 300
	101.600	34.925	36.068	26.988	3.6	3.2	131	159	4 000	5 300
104.775	30.162	30.958	23.812	6.4	3.2	126	165	3 700	4 900	
104.775	36.512	36.512	28.575	3.6	3.2	148	187	3 900	5 100	

[Note] 1) To the bearings with supplementary code "J" attached at the front of bearing number, tolerances shown in table 7-8 on page A66 are applied.

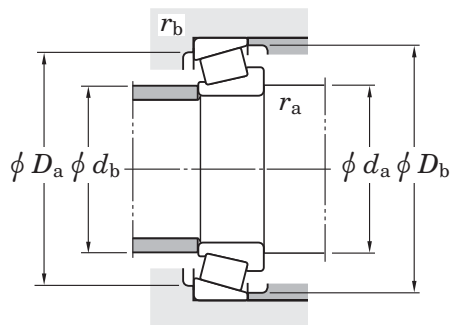

Bearing No. ¹⁾		Load center (mm) a	Mounting dimensions (mm)							Constant e	Axial load factors		(Refer.) Mass (kg)	
Inner ring	Outer ring		d_a	d_b	D_a	D_b	r_a max.	r_b max.	Y_1		Y_0	Inner ring	Outer ring	
28579R	28521	19.9	60.0	56.0	83.0	87.0	2.4	0.8	0.38	1.59	0.87	0.463	0.247	
JLM104948	JLM104910	16.2	60.0	55.0	76.0	78.0	3.0	0.5	0.31	1.97	1.08	0.304	0.128	
365	362A	16.1	58.0	55.0	81.0	84.0	2.0	1.2	0.32	1.88	1.03	0.346	0.164	
366	362A	16.1	59.0	55.0	81.0	84.0	2.4	1.2	0.32	1.88	1.03	0.351	0.166	
JM205149	JM205110	20.2	62.0	57.0	80.0	85.0	3.0	2.5	0.33	1.82	1.00	0.508	0.243	
JHM807045	JHM807012	29.4	69.0	63.0	90.0	100.0	3.0	2.8	0.49	1.23	0.68	1.01	0.523	
396	394A	21.3	61.0	60.0	101.0	105.0	0.8	1.2	0.40	1.49	0.82	0.777	0.264	
L305649R	L305610	16.0	58.0	56.0	73.0	77.0	1.6	1.6	0.35	1.69	0.93	0.228	0.119	
LM104949	LM104911	16.4	62.0	55.0	75.0	78.0	3.6	1.2	0.31	1.97	1.08	0.287	0.131	
18200	18337	22.7	59.0	56.0	76.0	81.0	1.6	1.6	0.57	1.06	0.58	0.268	0.134	
18790	18724	17.4	62.0	56.0	78.0	82.0	3.6	1.2	0.41	1.48	0.81	0.226	0.190	
368	362A	16.1	58.0	56.0	81.0	84.0	1.6	1.2	0.32	1.88	1.03	0.333	0.164	
368A	362A	16.1	62.0	56.0	81.0	84.0	3.6	1.2	0.32	1.88	1.03	0.331	0.164	
370A	362A	16.1	65.0	56.0	81.0	84.0	5.2	1.2	0.32	1.88	1.03	0.326	0.164	
28580R	28521	19.9	63.0	57.0	83.0	87.0	3.6	0.8	0.38	1.59	0.87	0.453	0.247	
375	374	17.1	60.0	57.0	85.0	88.0	2.4	1.2	0.34	1.77	0.97	0.416	0.174	
3780	3720	22.2	64.0	58.0	82.0	88.0	3.6	3.2	0.34	1.77	0.97	0.547	0.288	
3780	3730	22.2	64.0	58.0	84.0	88.0	3.6	0.8	0.34	1.77	0.97	0.547	0.293	
33889	33822	20.4	64.0	58.0	86.0	90.0	3.6	0.8	0.33	1.82	1.00	0.604	0.267	
385AX	382A	17.4	59.0	58.0	89.0	92.0	0.8	0.8	0.35	1.69	0.93	0.521	0.177	
28678	28622	21.2	65.0	58.0	88.0	92.0	3.6	0.8	0.40	1.49	0.82	0.569	0.267	
3780	3732	22.2	64.0	58.0	84.0	90.0	3.6	3.2	0.34	1.77	0.97	0.547	0.433	
49585	49520	24.1	66.0	59.0	88.0	96.0	3.6	3.2	0.40	1.50	0.82	0.736	0.384	
529	522	22.2	59.0	58.0	89.0	95.0	0.8	3.2	0.29	2.10	1.16	0.806	0.411	
529X	522	22.2	65.0	58.0	89.0	95.0	3.6	3.2	0.29	2.10	1.16	0.802	0.411	
45284	45220	22.2	71.0	59.0	93.0	99.0	6.4	3.2	0.33	1.80	0.99	0.873	0.345	
59200	59412	26.9	68.0	61.0	92.0	99.0	3.6	3.2	0.40	1.49	0.82	0.767	0.623	

[Remark] Inch series tapered roller bearings with bore diameter larger than 100 mm are shown in catalog "large size ball & roller bearings".

Single-row tapered roller bearings inch series

d (50.800) ~ (55.000) mm

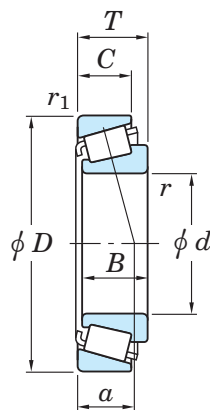

d	Boundary dimensions (mm)						Basic load ratings (kN)		Limiting speeds (min ⁻¹)	
	D	T	B	C	r min.	r_1 min.	C_r	C_{0r}	Grease lub.	Oil lub.
50.800	104.775	36.512	36.512	28.575	3.6	3.2	141	195	3 800	5 100
	104.775	39.688	40.157	33.338	3.6	3.2	151	211	3 800	5 100
	107.950	36.512	36.957	28.575	3.6	3.2	138	172	3 800	5 100
	112.712	30.162	30.162	23.812	3.6	3.2	147	207	3 300	4 500
	120.650	41.275	41.275	31.750	3.6	3.2	174	217	3 500	4 600
	127.000	44.450	44.450	34.925	3.6	3.2	208	269	3 300	4 400
51.592	88.900	20.638	22.225	16.513	2.0	1.2	74.3	87.3	4 400	5 800
52.388	92.075	24.608	25.400	19.845	3.6	0.8	84.8	119	4 200	5 600
	104.775	30.162	29.317	24.605	1.6	3.2	109	144	3 700	4 900
53.975	88.900	19.050	19.050	13.492	2.4	2.0	62.9	86.8	4 200	5 600
	95.250	27.783	28.575	22.225	1.6	0.8	108	141	4 100	5 400
	104.775	30.162	29.317	24.605	3.6	3.2	109	144	3 700	4 900
	104.775	36.512	36.512	28.575	3.6	3.2	141	195	3 800	5 100
	104.775	39.688	40.157	33.338	3.6	3.2	151	211	3 800	5 100
	107.950	36.512	36.957	28.575	3.6	3.2	138	172	3 800	5 100
	107.950	36.512	36.957	28.575	5.6	3.2	138	172	3 800	5 100
	117.475	33.338	31.750	23.812	3.6	3.2	129	152	3 500	4 600
	120.650	41.275	41.275	31.750	3.6	3.2	174	217	3 500	4 600
	122.238	33.338	31.750	23.812	3.6	3.2	128	153	3 300	4 300
	122.238	43.658	43.764	36.512	3.6	3.2	221	318	3 200	4 300
	123.825	38.100	36.678	30.162	3.6	3.2	162	223	3 200	4 200
	127.000	44.450	44.450	34.925	3.6	3.2	208	269	3 300	4 400
54.988	104.775	30.162	29.317	24.605	2.4	3.2	109	144	3 700	4 900
54.991	135.755	53.975	56.007	44.450	3.6	3.2	266	357	3 000	4 000
55.000	90.000	23.000	23.000	18.500	1.6	0.5	81.4	115	4 200	5 500

[Note] 1) To the bearings with supplementary code "J" attached at the front of bearing number, tolerances shown in table 7-8 on page A66 are applied.

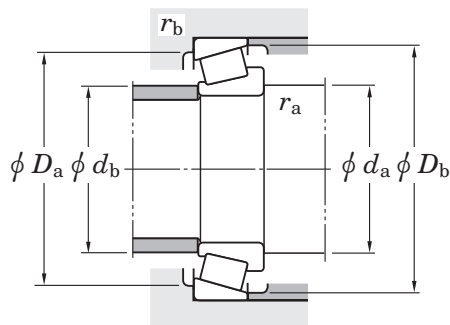

	Bearing No. ¹⁾		Load center (mm) <i>a</i>	Mounting dimensions (mm)						Constant <i>e</i>	Axial load factors		(Refer.) Mass (kg)	
	Inner ring	Outer ring		<i>d_a</i>	<i>d_b</i>	<i>D_a</i>	<i>D_b</i>	<i>r_a</i> max.	<i>r_b</i> max.		<i>Y₁</i>	<i>Y₀</i>	Inner ring	Outer ring
	HM807046	HM807010	29.3	70.0	63.0	89.0	100.0	3.6	3.2	0.49	1.23	0.68	0.995	0.497
	4580	4535	27.3	67.0	61.0	90.0	99.0	3.6	3.2	0.34	1.79	0.98	1.06	0.576
	537	532X	23.9	65.0	59.0	94.0	100.0	3.6	3.2	0.30	2.03	1.11	0.969	0.569
	39575	39520	23.3	68.0	61.0	101.0	107.0	3.6	3.2	0.34	1.77	0.97	1.13	0.355
	619	612	27.3	67.0	61.0	105.0	110.0	3.6	3.2	0.31	1.91	1.05	1.44	0.853
	65200	65500	35.2	75.0	69.0	107.0	119.0	3.6	3.2	0.49	1.23	0.68	1.86	1.03
	368S	362A	16.1	59.0	56.0	81.0	84.0	2.0	1.2	0.32	1.88	1.03	0.321	0.164
	28584R	28521	19.9	65.0	58.0	83.0	87.0	3.6	0.8	0.38	1.59	0.87	0.435	0.247
	468	453X	23.6	62.0	60.0	92.0	98.0	1.6	3.2	0.34	1.79	0.98	0.748	0.372
	LM806649	LM806610	21.5	63.0	60.0	80.0	85.0	2.4	2.0	0.55	1.10	0.60	0.312	0.135
	33895	33822	20.4	63.0	60.0	86.0	90.0	1.6	0.8	0.33	1.82	1.00	0.550	0.267
	456	453X	23.6	68.0	61.0	92.0	98.0	3.6	3.2	0.34	1.79	0.98	0.728	0.372
	HM807049	HM807010	29.3	73.0	63.0	89.0	100.0	3.6	3.2	0.49	1.23	0.68	0.921	0.497
	4595	4535	27.3	70.0	63.0	90.0	99.0	3.6	3.2	0.34	1.79	0.98	0.981	0.576
	539	532X	23.9	68.0	61.0	94.0	100.0	3.6	3.2	0.30	2.03	1.11	0.894	0.569
	539A	532X	23.9	72.0	61.0	94.0	100.0	5.6	3.2	0.30	2.03	1.11	0.861	0.569
	66212R	66462	33.2	73.0	67.0	100.0	111.0	3.6	3.2	0.63	0.96	0.53	1.03	0.552
	621	612	27.3	70.0	63.0	105.0	110.0	3.6	3.2	0.31	1.91	1.05	1.36	0.853
	66584	66520	35.4	75.0	68.0	105.0	116.0	3.6	3.2	0.67	0.90	0.50	1.25	0.551
	5578R	5535	31.1	73.0	67.0	106.0	116.0	3.6	3.2	0.36	1.67	0.92	1.84	0.807
	557S	552A	28.7	71.0	65.0	109.0	116.0	3.6	3.2	0.35	1.73	0.95	1.47	0.756
	65212	65500	35.2	77.0	71.0	107.0	119.0	3.6	3.2	0.49	1.23	0.68	1.78	1.02
	466	453X	23.6	67.0	61.0	92.0	98.0	2.4	3.2	0.34	1.79	0.98	0.708	0.372
	6381	6320	34.8	76.0	70.0	117.0	126.0	3.6	3.2	0.32	1.85	1.02	2.75	1.37
	JLM506849	JLM506810	20.1	63.0	61.0	82.0	86.0	1.6	0.5	0.40	1.49	0.82	0.370	0.183

[Remark] Inch series tapered roller bearings with bore diameter larger than 100 mm are shown in catalog "large size ball & roller bearings".

Single-row tapered roller bearings inch series

d (55.000) ~ (60.000) mm

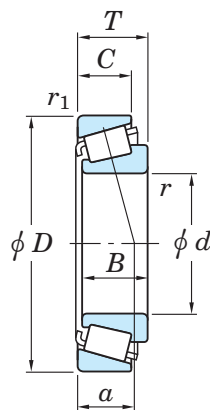

d	Boundary dimensions (mm)						Basic load ratings (kN)		Limiting speeds (min ⁻¹)	
	D	T	B	C	r min.	r_1 min.	C_r	C_{0r}	Grease lub.	Oil lub.
55.000	95.000	29.000	29.000	23.500	1.6	2.8	110	150	4 000	5 300
	96.838	21.000	21.946	15.875	2.4	0.8	80.4	101	3 900	5 200
	96.838	21.000	21.946	15.875	3.6	0.8	80.4	101	3 900	5 200
	110.000	39.000	39.000	32.000	3.0	2.5	176	224	3 600	4 900
55.562	97.630	24.608	24.608	19.446	3.6	0.8	89.6	131	3 900	5 200
	122.238	43.658	43.764	36.512	1.2	3.2	221	318	3 200	4 300
	127.000	36.512	36.512	26.988	3.6	3.2	166	235	3 000	4 000
55.575	96.838	21.000	21.946	15.875	2.4	0.8	80.4	101	3 900	5 200
57.150	96.838	21.000	21.946	15.875	2.4	0.8	80.4	101	3 900	5 200
	96.838	21.000	21.946	15.875	3.6	0.8	80.4	101	3 900	5 200
	96.838	21.000	21.946	15.875	5.2	0.8	80.4	101	3 900	5 200
	96.838	21.000	21.946	15.875	0.8	0.8	80.4	101	3 900	5 200
	98.425	21.000	21.946	17.826	2.4	0.8	80.4	101	3 900	5 200
	104.775	30.162	29.317	24.605	2.4	3.2	109	144	3 700	4 900
	104.775	30.162	29.317	24.605	3.6	3.2	109	144	3 700	4 900
	104.775	30.162	30.958	23.812	6.4	0.8	126	165	3 700	4 900
	112.712	30.162	30.048	23.812	3.6	3.2	111	164	3 400	4 500
	112.712	30.162	30.162	23.812	3.6	3.2	147	207	3 300	4 500
	112.712	30.162	30.162	23.812	7.9	3.2	147	207	3 300	4 500
	117.475	30.162	30.162	23.812	3.6	3.2	118	179	3 200	4 200
	120.650	41.275	41.275	31.750	3.6	3.2	174	217	3 500	4 600
127.000	44.450	44.450	34.925	3.6	3.2	208	269	3 300	4 400	
57.531	96.838	21.000	21.946	15.875	3.6	0.8	80.4	101	3 900	5 200
59.972	122.238	33.338	31.750	23.812	0.8	3.2	128	153	3 300	4 300
60.000	95.000	24.000	24.000	19.000	5.0	2.5	86.1	125	3 900	5 200

[Note] 1) To the bearings with supplementary code "J" attached at the front of bearing number, tolerances shown in table 7-8 on page A66 are applied.

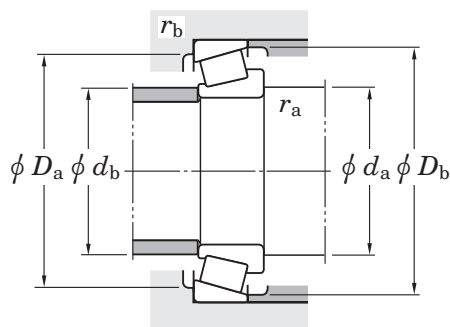

Bearing No. ¹⁾		Load center (mm) <i>a</i>	Mounting dimensions (mm)							Constant <i>e</i>	Axial load factors		(Refer.) Mass (kg)	
Inner ring	Outer ring		<i>d_a</i>	<i>d_b</i>	<i>D_a</i>	<i>D_b</i>	<i>r_a</i> max.	<i>r_b</i> max.	<i>Y₁</i>		<i>Y₀</i>	Inner ring	Outer ring	
JM207049 385 385X	JM207010	21.3	64.0	62.0	85.0	91.0	1.6	2.8	0.33	1.79	0.99	0.567	0.256	
	382A	17.4	65.0	61.0	89.0	92.0	2.4	0.8	0.35	1.69	0.93	0.461	0.177	
	382A	17.4	67.0	61.0	89.0	92.0	3.6	0.8	0.35	1.69	0.93	0.459	0.177	
	JH307749	26.8	71.0	64.0	97.0	104.0	3.0	2.5	0.35	1.73	0.95	1.16	0.560	
28680 5566R HM813840	28622	21.2	68.0	62.0	88.0	92.0	3.6	0.8	0.40	1.49	0.82	0.492	0.267	
	5535	31.1	70.0	68.0	106.0	116.0	1.2	3.2	0.36	1.67	0.92	1.82	0.807	
	HM813810	32.9	76.0	70.0	111.0	121.0	3.6	3.2	0.50	1.20	0.66	1.72	0.606	
389	382A	17.4	65.0	61.0	89.0	92.0	2.4	0.8	0.35	1.69	0.93	0.452	0.177	
387 387A 387AS 387S 387 462 469 45291 3979 39580 39581 33225 623 65225	382A	17.4	66.0	62.0	89.0	92.0	2.4	0.8	0.35	1.69	0.93	0.428	0.177	
	382A	17.4	69.0	62.0	89.0	92.0	3.6	0.8	0.35	1.69	0.93	0.426	0.177	
	382A	17.4	72.0	62.0	89.0	92.0	5.2	0.8	0.35	1.69	0.93	0.422	0.177	
	382A	17.4	63.0	62.0	89.0	92.0	0.8	0.8	0.35	1.69	0.93	0.431	0.177	
	382	17.4	66.0	62.0	89.0	92.0	2.4	0.8	0.35	1.69	0.93	0.428	0.223	
	453X	23.6	67.0	63.0	92.0	98.0	2.4	3.2	0.34	1.79	0.98	0.685	0.372	
	453X	23.6	70.0	63.0	92.0	98.0	3.6	3.2	0.34	1.79	0.98	0.682	0.372	
	45221	22.2	76.0	65.0	95.0	99.0	6.4	0.8	0.33	1.80	0.99	0.742	0.350	
	3920	25.9	72.0	66.0	99.0	106.0	3.6	3.2	0.40	1.49	0.82	0.916	0.448	
	39520	23.3	72.0	66.0	101.0	107.0	3.6	3.2	0.34	1.77	0.97	1.05	0.355	
	39520	23.3	81.0	66.0	101.0	107.0	7.9	3.2	0.34	1.77	0.97	1.03	0.355	
	33462	27.8	74.0	68.0	104.0	112.0	3.6	3.2	0.44	1.38	0.76	1.13	0.442	
	612	27.3	72.0	66.0	105.0	110.0	3.6	3.2	0.31	1.91	1.05	1.27	0.853	
65500	35.2	80.0	71.0	107.0	119.0	3.6	3.2	0.49	1.23	0.68	1.69	1.02		
388A	382A	17.4	69.0	63.0	89.0	92.0	3.6	0.8	0.35	1.69	0.93	0.420	0.177	
66589	66520	35.4	74.0	73.0	105.0	116.0	0.8	3.2	0.67	0.90	0.50	1.11	0.551	
JLM508748	JLM508710	21.2	75.0	66.0	85.0	91.0	5.0	2.5	0.40	1.49	0.82	0.402	0.196	

[Remark] Inch series tapered roller bearings with bore diameter larger than 100 mm are shown in catalog "large size ball & roller bearings".

Single-row tapered roller bearings inch series

d (60.000) ~ (65.000) mm

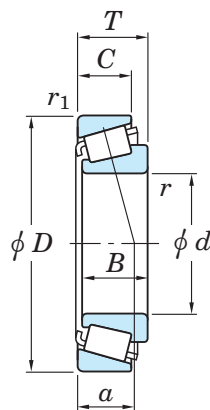

d	Boundary dimensions (mm)						Basic load ratings (kN)		Limiting speeds (min ⁻¹)	
	D	T	B	C	r min.	r_1 min.	C_r	C_{0r}	Grease lub.	Oil lub.
60.000	107.950	25.400	25.400	19.050	3.6	3.2	92.8	143	3 400	4 500
	110.000	22.000	21.996	18.824	0.8	1.2	86.4	116	3 400	4 500
60.325	100.000	25.400	25.400	19.845	3.6	3.2	91.4	137	3 700	4 900
	101.600	25.400	25.400	19.845	3.6	3.2	91.4	137	3 700	4 900
	122.238	43.658	43.764	36.512	3.6	3.2	221	318	3 200	4 300
	127.000	36.512	36.512	26.988	3.6	1.6	166	235	3 000	4 000
	127.000	36.512	36.512	26.988	1.6	3.2	166	235	3 000	4 000
	127.000	44.450	44.450	34.925	3.6	3.2	208	269	3 300	4 400
	127.000	44.450	44.450	34.925	1.6	3.2	208	269	3 300	4 400
	136.525	46.038	46.038	36.512	3.6	3.2	231	369	2 800	3 700
61.912	110.000	22.000	21.996	18.824	0.8	1.2	86.4	116	3 400	4 500
63.500	107.950	25.400	25.400	19.050	1.6	3.2	92.8	143	3 400	4 500
	110.000	22.000	21.996	18.824	1.6	1.2	86.4	116	3 400	4 500
	110.000	22.000	21.996	18.824	3.6	1.2	86.4	116	3 400	4 500
	110.000	25.400	25.400	19.050	3.6	1.2	92.8	143	3 400	4 500
	112.712	30.162	30.162	23.812	3.6	3.2	147	207	3 300	4 500
	120.000	29.794	29.007	24.237	0.8	2.0	118	161	3 200	4 200
	122.238	38.354	38.100	29.718	3.6	3.2	191	249	3 200	4 300
	122.238	43.658	43.764	36.512	3.6	3.2	221	318	3 200	4 300
	127.000	36.512	36.170	28.575	3.6	3.2	156	226	3 000	4 000
	135.755	53.975	56.007	44.450	4.3	3.2	266	357	3 000	4 000
	136.525	41.275	41.275	31.750	3.6	3.2	241	308	2 900	3 800
	64.986	112.712	30.162	30.924	23.812	2.4	3.2	147	207	3 300
65.000	105.000	24.000	23.000	18.500	3.0	1.0	95.3	129	3 500	4 700
	110.000	28.000	28.000	22.500	3.0	2.8	136	191	3 400	4 600

[Note] 1) To the bearings with supplementary code "J" attached at the front of bearing number, tolerances shown in table 7-8 on page A66 are applied.

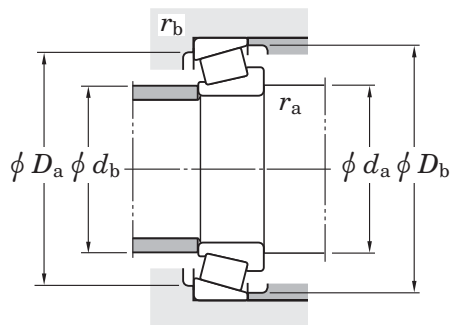

Bearing No. ¹⁾		Load center (mm) <i>a</i>	Mounting dimensions (mm)							Constant <i>e</i>	Axial load factors		(Refer.) Mass (kg)	
Inner ring	Outer ring		<i>d_a</i>	<i>d_b</i>	<i>D_a</i>	<i>D_b</i>	<i>r_a</i> max.	<i>r_b</i> max.	<i>Y₁</i>		<i>Y₀</i>	Inner ring	Outer ring	
29580	29520	24.7	74.0	68.0	96.0	103.0	3.6	3.2	0.46	1.31	0.72	0.713	0.277	
397	394A	21.3	69.0	68.0	101.0	104.5	0.8	1.2	0.40	1.49	0.82	0.637	0.259	
28985	28921	22.8	73.0	67.0	89.0	96.0	3.6	3.2	0.43	1.41	0.78	0.533	0.230	
28985	28920	22.8	73.0	67.0	89.0	96.0	3.6	3.2	0.43	1.41	0.78	0.533	0.269	
5583R	5535	31.1	78.0	72.0	106.0	116.0	3.6	3.2	0.36	1.67	0.92	1.66	0.807	
HM813841	HM813811	32.9	80.0	73.0	113.0	121.0	3.6	1.6	0.50	1.20	0.66	1.60	0.622	
HM813841A	HM813810	32.9	74.0	71.0	110.0	121.0	1.6	3.2	0.50	1.20	0.66	1.62	0.606	
65237	65500	35.2	82.0	71.0	107.0	119.0	3.6	3.2	0.49	1.23	0.68	1.59	1.02	
65237A	65500	35.2	78.0	71.0	107.0	119.0	1.6	3.2	0.49	1.23	0.68	1.59	1.02	
H715332	H715311	37.0	84.0	78.0	118.0	132.0	3.6	3.2	0.47	1.27	0.70	2.56	0.950	
392	394A	21.3	70.0	69.0	101.0	104.5	0.8	1.2	0.40	1.49	0.82	0.606	0.259	
29586	29520	24.7	73.0	71.0	96.0	103.0	1.6	3.2	0.46	1.31	0.72	0.649	0.277	
390A	394A	21.3	73.0	70.0	101.0	104.5	1.6	1.2	0.40	1.49	0.82	0.579	0.259	
395	394A	21.3	77.0	70.0	101.0	104.5	3.6	1.2	0.40	1.49	0.82	0.575	0.259	
29585	29521	24.7	77.0	71.0	99.0	104.0	3.6	1.2	0.46	1.31	0.72	0.644	0.333	
39585	39520	23.3	77.0	71.0	101.0	107.0	3.6	3.2	0.34	1.77	0.97	0.908	0.355	
477	472	25.7	73.0	72.0	108.0	113.0	0.8	2.0	0.38	1.56	0.86	0.967	0.493	
HM212046	HM212011	27.6	80.0	73.0	108.0	116.0	3.6	3.2	0.34	1.78	0.98	1.36	0.591	
5584R	5535	31.1	81.0	75.0	106.0	116.0	3.6	3.2	0.36	1.67	0.92	1.56	0.807	
565	563	28.6	80.0	73.0	112.0	120.0	3.6	3.2	0.36	1.65	0.91	1.43	0.648	
6382	6320	34.8	84.0	77.0	117.0	126.0	4.3	3.2	0.32	1.85	1.02	2.29	1.39	
H414235	H414210	30.3	82.0	78.0	121.0	129.0	3.6	3.2	0.36	1.67	0.92	2.11	0.796	
39586	39520	23.3	76.0	72.0	101.0	107.0	2.4	3.2	0.34	1.77	0.97	0.845	0.355	
JLM710949	JLM710910	23.8	77.0	71.0	96.0	100.5	3.0	1.0	0.45	1.32	0.73	0.513	0.234	
JM511946	JM511910	24.5	78.0	72.0	99.0	105.0	3.0	2.8	0.40	1.49	0.82	0.733	0.338	

[Remark] Inch series tapered roller bearings with bore diameter larger than 100 mm are shown in catalog "large size ball & roller bearings".

Single-row tapered roller bearings inch series

d (65.000) ~ 68.262 mm

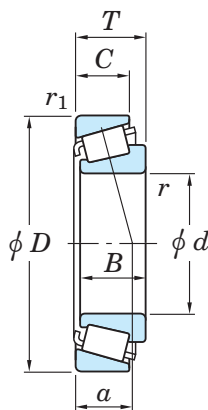

d	Boundary dimensions (mm)						Basic load ratings (kN)		Limiting speeds (min ⁻¹)	
	D	T	B	C	r min.	r_1 min.	C_r	C_{0r}	Grease lub.	Oil lub.
65.000	120.000	39.000	38.500	32.000	3.0	2.8	189	255	3 200	4 300
	120.000	39.000	38.500	32.000	7.1	2.8	189	255	3 200	4 300
65.088	135.755	53.975	56.007	44.450	3.6	3.2	266	357	3 000	4 000
	136.525	46.038	46.038	36.512	3.6	3.2	231	369	2 800	3 700
65.883	122.238	43.658	43.764	36.512	3.6	3.2	221	318	3 200	4 300
66.675	110.000	22.000	21.996	18.824	0.8	1.2	86.4	116	3 400	4 500
	110.000	22.000	21.996	18.824	3.6	1.2	86.4	116	3 400	4 500
	112.712	30.162	30.048	23.812	3.6	0.8	111	164	3 400	4 500
	112.712	30.162	30.162	23.812	3.6	3.2	147	207	3 300	4 500
	112.712	30.162	30.162	23.812	3.6	0.8	147	207	3 300	4 500
	117.475	30.162	30.162	23.812	3.6	3.2	118	179	3 200	4 200
	122.238	38.100	38.354	29.718	3.6	1.6	191	249	3 200	4 300
	127.000	36.512	36.512	26.988	3.6	1.6	166	235	3 000	4 000
	130.175	41.275	41.275	31.750	3.6	3.2	197	267	3 000	3 900
	135.755	53.975	56.007	44.450	4.3	3.2	266	357	3 000	4 000
	135.755	53.975	56.007	44.450	6.4	3.2	266	357	3 000	4 000
	136.525	41.275	41.275	31.750	3.6	3.2	241	308	2 900	3 800
	136.525	46.038	46.038	36.512	3.6	3.2	231	369	2 800	3 700
68.262	110.000	22.000	21.996	18.824	2.4	1.2	86.4	116	3 400	4 500
	110.000	22.000	21.996	18.824	5.2	1.2	86.4	116	3 400	4 500
	117.475	30.162	30.162	23.812	3.6	3.2	118	179	3 200	4 200
	127.000	36.512	36.170	28.575	3.6	3.2	156	226	3 000	4 000
	136.525	41.275	41.275	31.750	3.6	3.2	241	308	2 900	3 800
	136.525	46.038	46.038	36.512	3.6	3.2	231	369	2 800	3 700
	152.400	47.625	46.038	31.750	3.6	3.2	244	278	2 700	3 600

[Note] 1) To the bearings with supplementary code "J" attached at the front of bearing number, tolerances shown in table 7-8 on page A66 are applied.

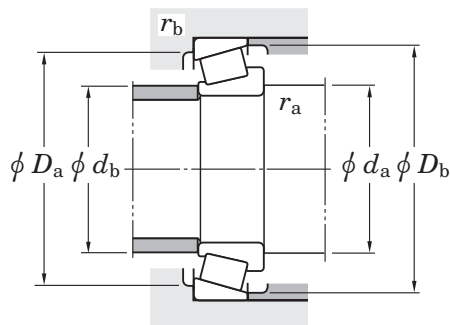

Bearing No. ¹⁾		Load center (mm) a	Mounting dimensions (mm)						Constant e	Axial load factors		(Refer.) Mass (kg)	
Inner ring	Outer ring		d_a	d_b	D_a	D_b	r_a max.	r_b max.		Y_1	Y_0	Inner ring	Outer ring
JH211749	JH211710	27.9	80.0	74.0	107.0	114.0	3.0	2.8	0.34	1.78	0.98	1.27	0.618
JH211749A	JH211710	27.9	88.0	74.0	107.0	114.0	7.1	2.8	0.34	1.78	0.98	1.27	0.618
6379	6320	34.8	84.0	77.5	117.0	126.0	3.6	3.2	0.32	1.85	1.02	2.34	1.37
H715340	H715311	37.0	88.0	82.0	118.0	132.0	3.6	3.2	0.47	1.27	0.70	2.39	0.950
5595R	5535	31.1	83.0	77.0	106.0	116.0	3.6	3.2	0.36	1.67	0.92	1.48	0.807
395A	394A	21.3	73.0	73.0	101.0	104.5	0.8	1.2	0.40	1.49	0.82	0.524	0.259
395S	394A	21.3	79.0	73.0	101.0	104.5	3.6	1.2	0.40	1.49	0.82	0.519	0.259
3984	3925	25.9	80.0	74.0	101.0	106.0	3.6	0.8	0.40	1.49	0.82	0.700	0.454
39590	39520	23.3	80.0	74.0	101.0	107.0	3.6	3.2	0.34	1.77	0.97	0.832	0.355
39590	39521	23.3	80.0	74.0	103.0	107.0	3.6	0.8	0.34	1.77	0.97	0.832	0.360
33262	33462	27.8	81.0	75.0	104.0	112.0	3.6	3.2	0.44	1.38	0.76	0.910	0.436
HM212049	HM212010	27.3	82.0	75.5	110.0	116.0	3.6	1.6	0.34	1.78	0.98	1.26	0.596
HM813844	HM813811	32.9	85.0	78.0	113.0	121.0	3.6	1.6	0.50	1.20	0.66	1.42	0.622
641	633	30.3	83.0	77.0	116.0	124.0	3.6	3.2	0.36	1.66	0.91	1.68	0.703
6386	6320	34.8	87.0	77.5	117.0	126.0	4.3	3.2	0.32	1.85	1.02	2.27	1.37
6389	6320	34.8	91.0	77.5	117.0	126.0	6.4	3.2	0.32	1.85	1.02	2.15	1.37
H414242	H414210	30.3	85.0	81.0	121.0	129.0	3.6	3.2	0.36	1.67	0.92	2.01	0.796
H715341	H715311	37.0	89.0	83.0	118.0	132.0	3.6	3.2	0.47	1.27	0.70	2.33	0.950
399A	394A	21.3	78.0	74.0	101.0	104.5	2.4	1.2	0.40	1.49	0.82	0.493	0.259
399AS	394A	21.3	83.0	74.0	101.0	104.5	5.2	1.2	0.40	1.49	0.82	0.485	0.259
33269	33462	27.8	82.0	76.0	104.0	112.0	3.6	3.2	0.44	1.38	0.76	0.870	0.436
570	563	28.6	83.0	77.0	112.0	120.0	3.6	3.2	0.36	1.65	0.91	1.29	0.648
H414245	H414210	30.3	86.0	82.0	121.0	129.0	3.6	3.2	0.36	1.67	0.92	1.92	0.788
H715343	H715311	37.0	90.0	84.0	118.0	132.0	3.6	3.2	0.47	1.27	0.70	2.27	0.950
9185	9121	44.5	94.0	81.5	130.0	145.0	3.6	3.2	0.66	0.91	0.50	2.67	1.20

[Remark] Inch series tapered roller bearings with bore diameter larger than 100 mm are shown in catalog "large size ball & roller bearings".

Single-row tapered roller bearings inch series

d 69.850 ~ (73.025) mm

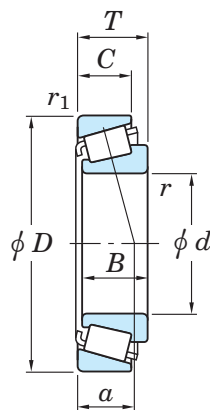

d	Boundary dimensions (mm)						Basic load ratings (kN)		Limiting speeds (min ⁻¹)	
	D	T	B	C	r min.	r_1 min.	C_r	C_{0r}	Grease lub.	Oil lub.
69.850	98.425	13.495	13.495	9.525	1.6	1.6	39.3	59.8	3 500	4 700
	112.712	22.225	21.996	15.875	1.6	0.8	91.6	127	3 300	4 400
	112.712	25.400	25.400	19.050	1.6	3.2	97.0	155	3 200	4 300
	117.475	30.162	30.162	23.812	3.6	3.2	118	179	3 200	4 200
	120.000	29.002	29.007	23.444	3.6	3.2	118	161	3 200	4 200
	120.000	29.794	29.007	24.237	3.6	2.0	118	161	3 200	4 200
	120.000	32.545	32.545	26.195	3.6	3.2	150	218	3 100	4 200
	120.650	32.545	32.545	26.195	3.6	0.8	150	218	3 100	4 200
	123.825	30.162	29.007	24.605	3.6	3.2	118	161	3 200	4 200
	127.000	36.512	36.170	28.575	3.6	3.2	156	226	3 000	4 000
	146.050	41.275	41.275	31.750	3.6	3.2	208	301	2 600	3 400
	150.089	44.450	46.672	36.512	3.6	3.2	264	368	2 500	3 400
	168.275	53.975	56.363	41.275	3.6	3.2	344	467	2 300	3 100
69.952	121.442	24.608	23.012	17.462	2.0	2.0	90.0	127	3 000	4 000
70.000	110.000	26.000	25.000	20.500	1.0	2.5	103	158	3 300	4 400
	115.000	29.000	29.000	23.000	3.0	2.5	123	173	3 200	4 300
71.438	117.475	30.162	30.162	23.812	3.6	3.2	118	179	3 200	4 200
	120.000	32.545	32.545	26.195	3.6	3.2	150	218	3 100	4 200
	127.000	36.512	36.170	28.575	3.6	3.2	156	226	3 000	4 000
	127.000	36.512	36.512	26.988	3.6	1.6	166	235	3 000	4 000
	136.525	41.275	41.275	31.750	3.6	3.2	241	308	2 900	3 800
	136.525	46.038	46.038	36.512	3.6	3.2	231	369	2 800	3 700
73.025	112.712	25.400	25.400	19.050	3.6	3.2	97.0	155	3 200	4 300
	117.475	30.162	30.162	23.812	3.6	3.2	118	179	3 200	4 200
	127.000	36.512	36.170	28.575	3.6	3.2	156	226	3 000	4 000
	139.992	36.512	36.098	28.575	3.6	3.2	175	262	2 700	3 600

[Note] 1) To the bearings with supplementary code "J" attached at the front of bearing number, tolerances shown in table 7-8 on page A66 are applied.

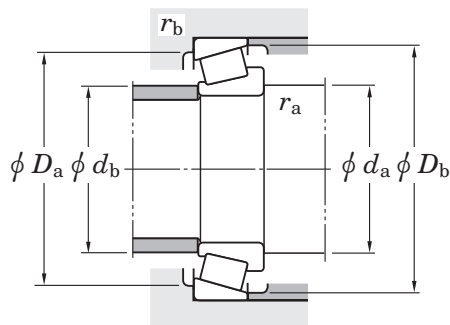

Bearing No. ¹⁾		Load center (mm) a	Mounting dimensions (mm)							Constant e	Axial load factors		(Refer.) Mass (kg)	
Inner ring	Outer ring		d_a	d_b	D_a	D_b	r_a max.	r_b max.	Y_1		Y_0	Inner ring	Outer ring	
LL713049	LL713010	18.4	77.0	74.0	92.0	94.0	1.6	1.6	0.44	1.37	0.75	0.205	0.086	
LM613449	LM613410	21.9	78.0	76.0	104.0	107.0	1.6	0.8	0.42	1.44	0.79	0.562	0.238	
29675	29620	26.2	80.0	77.0	101.0	109.0	1.6	3.2	0.49	1.23	0.68	0.676	0.270	
33275	33462	27.8	84.0	77.0	104.0	112.0	3.6	3.2	0.44	1.38	0.76	0.830	0.436	
482	472A	24.9	83.0	77.0	106.0	114.0	3.6	3.2	0.38	1.56	0.86	0.791	0.462	
482	472	25.7	83.0	77.0	108.0	113.0	3.6	2.0	0.38	1.56	0.86	0.791	0.487	
47487R	47420	26.6	84.0	78.0	107.0	114.0	3.6	3.2	0.36	1.67	0.92	1.01	0.476	
47487R	47423	26.6	84.0	78.0	109.0	114.0	3.6	0.8	0.36	1.67	0.92	1.01	0.513	
482	472X	26.0	83.0	77.0	109.0	114.0	3.6	3.2	0.38	1.56	0.86	0.791	0.625	
566	563	28.6	85.0	78.0	112.0	120.0	3.6	3.2	0.36	1.65	0.91	1.24	0.648	
655	653	33.4	88.0	82.0	131.0	139.0	3.6	3.2	0.41	1.47	0.81	2.35	0.891	
745AR	742	32.4	88.0	82.0	134.0	142.0	3.6	3.2	0.33	1.84	1.01	2.79	1.07	
835R	832	35.0	91.0	84.0	149.0	155.0	3.6	3.2	0.30	2.00	1.10	4.32	1.72	
34274	34478	26.8	81.0	78.0	110.0	116.0	2.0	2.0	0.45	1.33	0.73	0.764	0.316	
JLM813049	JLM813010	26.1	78.0	77.0	98.0	105.0	1.0	2.5	0.49	1.23	0.68	0.590	0.300	
JM612949	JM612910	26.2	83.0	77.0	103.0	110.0	3.0	2.5	0.43	1.39	0.77	0.776	0.358	
33281	33462	27.8	85.0	79.0	104.0	112.0	3.6	3.2	0.44	1.38	0.76	0.789	0.436	
47490R	47420	26.6	86.0	79.0	107.0	114.0	3.6	3.2	0.36	1.67	0.92	0.964	0.476	
567A	563	28.6	86.0	80.0	112.0	120.0	3.6	3.2	0.36	1.65	0.91	1.19	0.648	
HM813849	HM813811	32.9	89.0	81.9	113.0	121.0	3.6	1.6	0.50	1.20	0.66	1.28	0.622	
H414249	H414210	30.3	89.0	83.3	121.0	129.0	3.6	3.2	0.36	1.67	0.92	1.80	0.788	
H715345	H715311	37.0	93.0	87.0	118.0	132.0	3.6	3.2	0.47	1.27	0.70	2.15	0.950	
29685	29620	26.2	86.0	80.0	101.0	109.0	3.6	3.2	0.49	1.23	0.68	0.602	0.270	
33287	33462	27.8	87.0	80.0	104.0	112.0	3.6	3.2	0.44	1.38	0.76	0.747	0.436	
567	563	28.6	88.0	81.0	112.0	120.0	3.6	3.2	0.36	1.65	0.91	1.14	0.648	
576R	572	31.0	90.0	83.0	125.0	133.0	3.6	3.2	0.40	1.49	0.82	1.74	0.779	

[Remark] Inch series tapered roller bearings with bore diameter larger than 100 mm are shown in catalog "large size ball & roller bearings".

Single-row tapered roller bearings inch series

d (73.025) ~ 76.200 mm

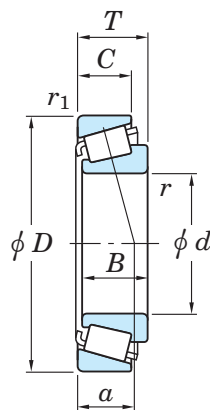

d	Boundary dimensions (mm)						Basic load ratings (kN)		Limiting speeds (min ⁻¹)	
	D	T	B	C	r min.	r_1 min.	C_r	C_{Or}	Grease lub.	Oil lub.
73.025	146.050	41.275	41.275	31.750	3.6	3.2	208	301	2 600	3 400
	149.225	53.975	54.229	44.450	3.6	3.2	285	404	2 700	3 500
	150.089	44.450	46.672	36.512	3.6	3.2	264	368	2 500	3 400
	161.925	47.625	48.260	38.100	3.6	3.2	273	391	2 400	3 200
73.817	112.712	25.400	25.400	19.050	1.6	3.2	97.0	155	3 200	4 300
	127.000	36.512	36.170	28.575	0.8	3.2	156	226	3 000	4 000
74.612	139.992	36.512	36.098	28.575	3.6	3.2	175	262	2 700	3 600
75.000	115.000	25.000	25.000	19.000	3.0	2.8	101	151	3 100	4 200
	120.000	31.000	29.500	25.000	3.0	2.8	145	216	3 100	4 100
	145.000	51.000	51.000	42.000	3.0	2.5	290	412	2 700	3 600
76.200	121.442	24.608	23.012	17.462	3.6	2.0	90.0	127	3 000	4 000
	127.000	30.162	31.000	22.225	3.6	3.2	143	225	2 400	3 200
	127.000	30.162	31.000	22.225	6.4	3.2	143	225	2 400	3 200
	133.350	30.162	29.769	22.225	6.4	3.2	133	198	2 700	3 600
	133.350	33.338	33.338	26.195	6.4	3.2	154	245	2 700	3 700
	133.350	33.338	33.338	26.195	0.8	3.2	154	245	2 700	3 700
	135.733	44.450	46.101	34.925	3.6	3.2	213	337	2 800	3 700
	136.525	30.162	29.769	22.225	3.6	3.2	133	198	2 700	3 600
	139.992	36.512	36.098	28.575	3.6	3.2	175	262	2 700	3 600
	139.992	36.512	36.098	28.575	6.7	3.2	175	262	2 700	3 600
	149.225	53.975	54.229	44.450	3.6	3.2	285	404	2 700	3 500
	149.225	53.975	54.229	44.450	9.5	3.2	285	404	2 700	3 500
	150.089	44.450	46.672	36.512	3.6	3.2	264	368	2 500	3 400
	152.400	41.275	41.275	31.750	3.6	3.2	208	301	2 600	3 400
	190.500	57.150	57.531	46.038	3.6	3.2	440	602	2 000	2 700

[Note] 1) To the bearings with supplementary code "J" attached at the front of bearing number, tolerances shown in table 7-8 on page A66 are applied.

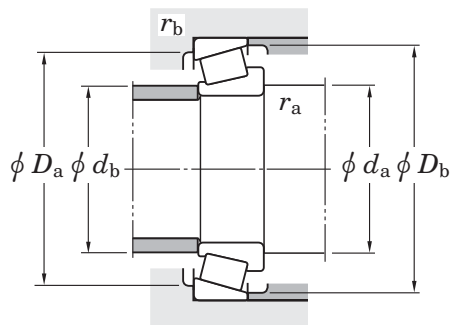

Bearing No. ¹⁾		Load center (mm) <i>a</i>	Mounting dimensions (mm)							Con- stant <i>e</i>	Axial load factors		(Refer.) Mass (kg)	
Inner ring	Outer ring		<i>d_a</i>	<i>d_b</i>	<i>D_a</i>	<i>D_b</i>	<i>r_a</i> max.	<i>r_b</i> max.	<i>Y₁</i>		<i>Y₀</i>	Inner ring	Outer ring	
657	653	33.4	90.0	85.0	131.0	139.0	3.6	3.2	0.41	1.47	0.81	2.28	0.880	
6460	6420	39.3	93.0	87.0	129.0	141.0	3.6	3.2	0.36	1.66	0.91	2.79	1.61	
744R	742	32.4	91.0	85.0	134.0	142.0	3.6	3.2	0.33	1.84	1.01	2.66	1.07	
762	752	35.5	92.0	97.0	144.0	150.0	3.6	3.2	0.34	1.76	0.97	3.18	1.61	
29688	29620	26.2	83.0	81.0	101.0	109.0	1.6	3.2	0.49	1.23	0.68	0.588	0.270	
568	563	28.6	83.0	82.0	112.0	120.0	0.8	3.2	0.36	1.65	0.91	1.12	0.648	
577R	572	31.0	91.0	85.0	125.0	133.0	3.6	3.2	0.40	1.49	0.82	1.69	0.779	
JLM714149	JLM714110	25.5	87.0	81.0	104.0	110.0	3.0	2.8	0.46	1.31	0.72	0.612	0.269	
JM714249	JM714210	30.0	88.0	82.9	108.0	115.0	3.0	2.8	0.44	1.35	0.74	0.846	0.430	
JH415647	JH415610	36.6	94.0	89.0	129.0	139.0	3.0	2.5	0.36	1.66	0.91	2.66	1.18	
34301	34478	26.8	89.0	83.0	110.0	116.0	3.6	2.0	0.45	1.33	0.73	0.617	0.313	
42687	42620	27.1	90.0	84.0	114.0	121.0	3.6	3.2	0.42	1.43	0.79	1.05	0.434	
42688	42620	27.1	96.0	84.0	114.0	121.0	6.4	3.2	0.42	1.43	0.79	1.04	0.434	
495AX	492A	29.8	98.0	86.0	120.0	128.0	6.4	3.2	0.44	1.35	0.74	1.20	0.430	
47678R	47620	29.2	97.0	90.0	119.0	128.0	6.4	3.2	0.40	1.48	0.82	1.29	0.577	
47680R	47620	29.2	86.0	85.0	119.0	128.0	0.8	3.2	0.40	1.48	0.82	1.39	0.577	
5760	5735	33.0	94.0	88.0	119.0	130.0	3.6	3.2	0.41	1.48	0.81	1.85	0.877	
495A	493	29.8	92.0	86.0	122.0	130.0	3.6	3.2	0.44	1.35	0.74	1.26	0.544	
575R	572	31.0	92.0	86.0	125.0	133.0	3.6	3.2	0.40	1.49	0.82	1.64	0.779	
575SR	572	31.0	99.0	86.0	125.0	133.0	6.7	3.2	0.40	1.49	0.82	1.61	0.779	
6461	6420	39.3	96.0	89.5	129.0	141.0	3.6	3.2	0.36	1.66	0.91	2.64	1.61	
6461A	6420	39.3	105.0	90.0	129.0	141.0	9.5	3.2	0.36	1.66	0.91	2.60	1.61	
748SR	742	32.4	93.0	87.0	134.0	142.0	3.6	3.2	0.33	1.84	1.01	2.51	1.06	
659	652	33.4	93.0	87.0	134.0	141.0	3.6	3.2	0.41	1.47	0.81	2.16	1.25	
HH221430	HH221410	42.5	101.0	95.0	171.0	179.0	3.6	3.2	0.33	1.79	0.99	6.33	2.21	

[Remark] Inch series tapered roller bearings with bore diameter larger than 100 mm are shown in catalog "large size ball & roller bearings".

Single-row tapered roller bearings inch series

d 77.788 ~ (83.345) mm

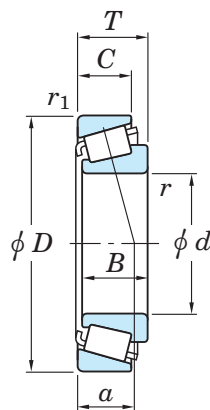

d	Boundary dimensions (mm)						Basic load ratings (kN)		Limiting speeds (min ⁻¹)	
	D	T	B	C	r min.	r_1 min.	C_r	C_{Or}	Grease lub.	Oil lub.
77.788	117.475	25.400	25.400	19.050	3.6	3.2	101	166	3 100	4 100
	121.442	24.608	23.012	17.462	3.6	2.0	90.0	127	3 000	4 000
	121.442	24.608	23.012	17.462	6.4	2.0	90.0	127	3 000	4 000
	127.000	30.162	31.000	22.225	3.6	3.2	143	225	2 400	3 200
79.375	146.050	41.275	41.275	31.750	3.6	3.2	208	301	2 600	3 400
	161.925	47.625	48.260	38.100	7.9	3.2	273	391	2 400	3 200
	190.500	57.150	57.531	46.038	3.6	3.2	440	602	2 000	2 700
80.000	130.000	35.000	34.000	28.500	3.2	2.5	168	256	2 800	3 800
	200.000	52.761	49.212	34.925	3.6	3.2	347	471	1 400	1 900
80.962	133.350	30.162	29.769	22.225	3.6	3.2	133	198	2 700	3 600
	133.350	33.338	33.338	26.195	3.6	3.2	154	245	2 700	3 700
	139.992	36.512	36.098	28.575	3.6	3.2	175	262	2 700	3 600
	150.089	44.450	46.672	36.512	5.2	3.2	264	368	2 500	3 400
82.550	125.412	25.400	25.400	19.845	3.6	1.6	101	162	2 900	3 800
	133.350	30.162	29.769	22.225	3.6	3.2	133	198	2 700	3 600
	133.350	33.338	33.338	26.195	3.6	0.8	154	245	2 700	3 700
	133.350	39.688	39.688	32.545	6.7	3.2	177	306	2 800	3 700
	139.700	36.512	36.098	28.575	3.6	3.2	175	262	2 700	3 600
	139.992	36.512	36.098	28.575	3.6	3.2	175	262	2 700	3 600
	139.992	36.512	36.098	28.575	6.7	3.2	175	262	2 700	3 600
	146.050	41.275	41.275	31.750	3.6	3.2	208	301	2 600	3 400
	150.089	44.450	46.672	36.512	3.6	3.2	264	368	2 500	3 400
	150.089	44.450	46.672	36.512	6.7	3.2	264	368	2 500	3 400
	161.925	47.625	48.260	38.100	3.6	3.2	273	391	2 400	3 200
83.345	125.412	25.400	25.400	19.845	0.8	1.6	101	162	2 900	3 800

[Note] 1) To the bearings with supplementary code "J" attached at the front of bearing number, tolerances shown in table 7-8 on page A66 are applied.

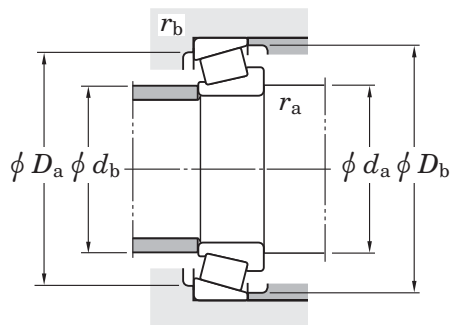

Bearing No. ¹⁾		Load center (mm) a	Mounting dimensions (mm)							Constant e	Axial load factors		(Refer.) Mass (kg)	
Inner ring	Outer ring		d_a	d_b	D_a	D_b	r_a max.	r_b max.	Y_1		Y_0	Inner ring	Outer ring	
LM814849	LM814810	27.6	91.0	85.0	105.0	113.0	3.6	3.2	0.51	1.18	0.65	0.619	0.295	
34306	34478	26.8	90.0	84.0	110.0	116.0	3.6	2.0	0.45	1.33	0.73	0.583	0.313	
34307	34478	26.8	96.0	84.0	110.0	116.0	6.4	2.0	0.45	1.33	0.73	0.571	0.313	
42690	42620	27.1	91.0	85.0	114.0	121.0	3.6	3.2	0.42	1.43	0.79	1.00	0.434	
661	653	33.4	96.0	90.0	131.0	139.0	3.6	3.2	0.41	1.47	0.81	2.04	0.880	
756A	752	35.5	106.0	91.0	144.0	150.0	7.9	3.2	0.34	1.76	0.97	2.95	1.59	
HH221431	HH221410	42.5	103.0	97.0	171.0	179.0	3.6	3.2	0.33	1.79	0.99	6.16	2.21	
JM515649	JM515610	29.6	94.0	88.0	117.0	125.0	3.2	2.5	0.39	1.54	0.85	1.19	0.575	
98316	98788	54.5	111.0	105.0	174.0	188.0	3.6	3.2	0.63	0.95	0.52	5.73	2.28	
496	492A	29.8	95.0	89.0	120.0	128.0	3.6	3.2	0.44	1.35	0.74	1.12	0.429	
47681R	47620	29.2	95.0	89.0	119.0	128.0	3.6	3.2	0.40	1.48	0.82	1.17	0.577	
581R	572	31.0	96.0	90.0	125.0	133.0	3.6	3.2	0.40	1.49	0.82	1.47	0.779	
740R	742	32.4	101.0	91.0	134.0	142.0	5.2	3.2	0.33	1.84	1.01	2.30	1.06	
27687	27620	24.7	96.0	89.0	115.0	120.0	3.6	1.6	0.42	1.44	0.79	0.710	0.344	
495	492A	29.8	97.0	90.0	120.0	128.0	3.6	3.2	0.44	1.35	0.74	1.08	0.429	
47686R	47620A	29.2	97.0	90.0	121.0	128.0	3.6	0.8	0.40	1.48	0.82	1.13	0.577	
HM516448	HM516410	32.2	105.0	92.0	118.0	128.0	6.7	3.2	0.40	1.49	0.82	1.33	0.763	
580R	572X	31.0	98.0	91.0	125.0	133.0	3.6	3.2	0.40	1.49	0.82	1.41	0.765	
580R	572	31.0	98.0	91.0	125.0	133.0	3.6	3.2	0.40	1.49	0.82	1.41	0.779	
582R	572	31.0	104.0	91.0	125.0	133.0	6.7	3.2	0.40	1.49	0.82	1.40	0.779	
663	653	33.4	99.0	92.0	131.0	139.0	3.6	3.2	0.41	1.47	0.81	1.91	0.880	
749AR	742	32.4	99.0	93.0	134.0	142.0	3.6	3.2	0.33	1.84	1.01	2.23	1.06	
750AR	742	32.4	106.0	93.0	134.0	142.0	6.7	3.2	0.33	1.84	1.01	2.19	1.06	
757	752	35.5	100.0	94.0	144.0	150.0	3.6	3.2	0.34	1.76	0.97	2.83	1.59	
27689	27620	24.7	90.0	90.0	115.0	120.0	0.8	1.6	0.42	1.44	0.79	0.746	0.344	

[Remark] Inch series tapered roller bearings with bore diameter larger than 100 mm are shown in catalog "large size ball & roller bearings".

Single-row tapered roller bearings inch series

d (83.345) ~ (88.900) mm

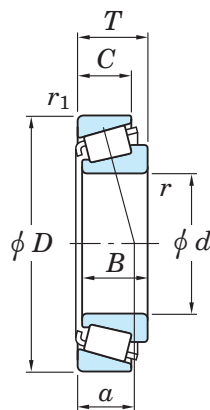

d	Boundary dimensions (mm)						Basic load ratings (kN)		Limiting speeds (min ⁻¹)	
	D	T	B	C	r min.	r_1 min.	C_r	C_{0r}	Grease lub.	Oil lub.
83.345	125.412	25.400	25.400	19.845	3.6	1.6	101	162	2 900	3 800
	125.412	25.400	25.400	19.845	6.4	1.6	101	162	2 900	3 800
84.138	133.350	30.162	29.769	22.225	3.6	3.2	133	198	2 700	3 600
85.000	130.000	30.000	29.000	24.000	3.0	2.5	142	228	2 800	3 700
	140.000	39.000	38.000	31.500	3.0	2.5	203	308	2 700	3 500
	150.000	46.000	46.000	38.000	3.0	2.5	274	390	2 500	3 400
	200.000	52.761	49.212	34.925	3.6	3.2	347	471	1 400	1 900
85.026	150.089	44.450	46.672	36.512	3.6	3.2	264	368	2 500	3 400
	150.089	44.450	46.672	36.512	5.2	3.2	264	368	2 500	3 400
85.725	133.350	30.162	29.769	22.225	3.6	3.2	133	198	2 700	3 600
	136.525	30.162	29.769	22.225	6.4	3.2	133	198	2 700	3 600
	142.138	42.862	42.862	34.133	4.8	3.2	219	351	2 600	3 500
	146.050	41.275	41.275	31.750	3.6	3.2	208	301	2 600	3 400
	146.050	41.275	41.275	31.750	6.4	3.2	208	301	2 600	3 400
	152.400	39.688	36.322	30.162	3.6	3.2	183	287	2 400	3 300
	161.925	47.625	48.260	38.100	3.6	3.2	273	391	2 400	3 200
	168.275	41.275	41.275	30.162	3.6	3.2	224	349	2 200	3 000
	168.275	53.975	56.363	41.275	3.6	3.2	344	467	2 300	3 100
88.900	123.825	20.638	20.638	16.670	1.6	1.6	81.8	145	2 800	3 700
	152.400	39.688	39.688	30.162	6.4	3.2	248	359	2 400	3 200
	161.925	47.625	48.260	38.100	3.6	3.2	273	391	2 400	3 200
	161.925	47.625	48.260	38.100	7.1	3.2	273	391	2 400	3 200
	161.925	53.975	55.100	42.862	3.6	3.2	316	471	2 400	3 200
	168.275	41.275	41.275	30.162	3.6	3.2	224	349	2 200	3 000
	190.500	57.150	57.531	44.450	7.9	3.2	385	565	2 100	2 700

[Note] 1) To the bearings with supplementary code "J" attached at the front of bearing number, tolerances shown in table 7-8 on page A66 are applied.

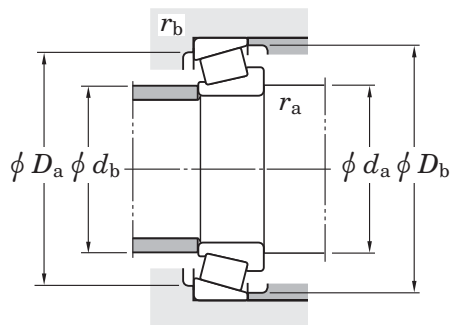

Bearing No. ¹⁾	Load center (mm) a	Mounting dimensions (mm)								Constant e	Axial load factors		(Refer.) Mass (kg)	
		Inner ring	Outer ring	d_a	d_b	D_a	D_b	r_a max.	r_b max.		Y_1	Y_0	Inner ring	Outer ring
27690	27620	24.7	96.0	90.0	115.0	120.0	3.6	1.6	0.42	1.44	0.79	0.689	0.344	
27691	27620	24.7	102.0	90.0	115.0	120.0	6.4	1.6	0.42	1.44	0.79	0.646	0.344	
498	492A	29.8	98.0	91.0	120.0	128.0	3.6	3.2	0.44	1.35	0.74	1.04	0.429	
JM716649	JM716610	29.1	98.0	92.0	117.0	125.0	3.0	2.5	0.44	1.35	0.74	0.937	0.456	
JHM516849	JHM516810	32.8	100.0	93.9	125.0	134.0	3.0	2.5	0.41	1.47	0.81	1.54	0.759	
JH217249	JH217210	33.6	101.0	95.2	134.0	142.0	3.0	2.5	0.33	1.80	0.99	2.28	1.08	
98335	98788	54.5	115.0	109.0	174.0	188.0	3.6	3.2	0.63	0.95	0.52	5.47	2.28	
749R	742	32.4	101.0	95.0	134.0	142.0	3.6	3.2	0.33	1.84	1.01	2.12	1.06	
749SR	742	32.4	104.0	95.0	134.0	142.0	5.2	3.2	0.33	1.84	1.01	2.08	1.06	
497	492A	29.8	99.0	93.0	120.0	128.0	3.6	3.2	0.44	1.35	0.74	0.978	0.429	
497A	493	29.8	105.0	93.0	122.0	130.0	6.4	3.2	0.44	1.35	0.74	0.965	0.544	
HM617049	HM617010	35.2	106.0	95.7	125.0	137.0	4.8	3.2	0.43	1.39	0.76	1.72	0.902	
665	653	33.4	102.0	95.0	131.0	139.0	3.6	3.2	0.41	1.47	0.81	1.77	0.880	
665A	653	33.4	107.0	95.0	131.0	139.0	6.4	3.2	0.41	1.47	0.81	1.76	0.880	
596	592A	37.1	102.0	96.0	135.0	144.0	3.6	3.2	0.44	1.36	0.75	1.83	1.04	
758	752	35.5	103.0	97.0	144.0	150.0	3.6	3.2	0.34	1.76	0.97	2.67	1.59	
677	672	38.6	105.0	99.0	149.0	160.0	3.6	3.2	0.47	1.28	0.70	2.89	1.22	
841R	832	35.0	104.0	97.0	149.0	155.0	3.6	3.2	0.30	2.00	1.10	3.47	1.72	
L217849	L217810	20.7	97.0	94.0	116.0	119.0	1.6	1.6	0.33	1.82	1.00	0.507	0.235	
HM518445	HM518410	33.1	110.0	98.0	135.0	114.0	6.4	3.2	0.40	1.49	0.82	2.10	0.768	
759	752	35.5	106.0	99.0	144.0	150.0	3.6	3.2	0.34	1.76	0.97	2.50	1.59	
766	752	35.5	113.0	99.0	144.0	150.0	7.1	3.2	0.34	1.76	0.97	2.48	1.59	
6580R	6535	49.8	109.0	98.0	141.0	154.0	3.6	3.2	0.40	1.50	0.82	3.09	1.65	
679	672	38.6	107.0	101.0	149.0	160.0	3.6	3.2	0.47	1.28	0.70	2.75	1.22	
855R	854	40.0	118.0	103.0	170.0	174.0	7.9	3.2	0.33	1.79	0.99	5.05	2.66	

[Remark] Inch series tapered roller bearings with bore diameter larger than 100 mm are shown in catalog "large size ball & roller bearings".

Single-row tapered roller bearings inch series

d (88.900) ~ 99.975 mm

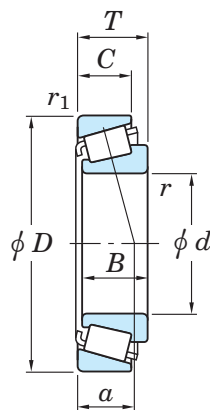

d	Boundary dimensions (mm)						Basic load ratings (kN)		Limiting speeds (min ⁻¹)	
	D	T	B	C	r min.	r_1 min.	C_r	C_{0r}	Grease lub.	Oil lub.
88.900	190.500	57.150	57.531	46.038	7.9	3.2	440	602	2 000	2 700
	200.000	52.761	49.212	34.925	3.6	3.2	347	471	1 400	1 900
89.974	146.975	40.000	40.000	32.500	7.1	3.6	206	310	2 500	3 300
90.000	145.000	35.000	34.000	27.000	3.0	2.5	194	291	2 500	3 400
	155.000	44.000	44.000	35.500	3.0	2.5	290	407	2 400	3 200
	161.925	53.975	55.100	42.862	3.0	3.2	316	471	2 400	3 200
90.488	161.925	47.625	48.260	38.100	3.6	3.2	273	391	2 400	3 200
92.075	146.050	33.338	34.925	26.195	3.6	3.2	178	293	2 500	3 300
	168.275	41.275	41.275	30.162	3.6	3.2	224	349	2 200	3 000
	168.275	41.275	41.275	30.162	6.4	3.2	224	349	2 200	3 000
	180.975	47.625	48.006	38.100	3.6	3.2	288	438	2 100	2 800
	190.500	57.150	57.531	44.450	7.9	3.2	385	565	2 100	2 700
95.000	150.000	35.000	34.000	27.000	3.0	2.5	187	294	2 400	3 300
95.250	128.588	15.875	15.083	11.908	1.6	1.6	58.0	93.0	2 600	3 500
	130.175	20.638	21.432	16.670	1.6	1.6	97.0	167	2 600	3 500
	146.050	33.338	34.925	26.195	3.6	3.2	178	293	2 500	3 300
	147.638	35.717	36.322	26.192	5.2	0.8	183	287	2 400	3 300
	157.162	36.512	36.116	26.195	3.6	3.2	180	288	2 300	3 000
	168.275	41.275	41.275	30.162	3.6	3.2	224	349	2 200	3 000
	190.500	57.150	57.531	44.450	7.9	3.2	385	565	2 100	2 700
	190.500	57.150	57.531	46.038	7.9	3.2	440	602	2 000	2 700
98.425	168.275	41.275	41.275	30.162	3.6	3.2	224	349	2 200	3 000
	190.500	57.150	57.531	46.038	3.6	3.2	440	602	2 000	2 700
99.975	212.725	66.675	66.675	53.975	3.6	3.2	513	699	1 800	2 400

[Note] 1) To the bearings with supplementary code "J" attached at the front of bearing number, tolerances shown in table 7-8 on page A66 are applied.

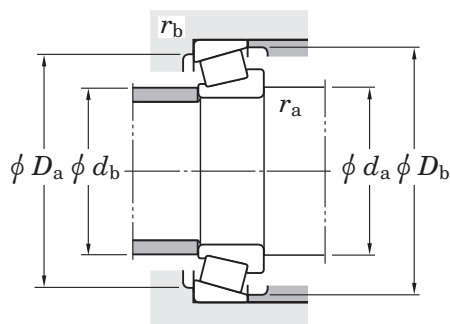

Bearing No. ¹⁾		Load center (mm) <i>a</i>	Mounting dimensions (mm)							Con- stant <i>e</i>	Axial load factors		(Refer.) Mass (kg)	
Inner ring	Outer ring		<i>d_a</i>	<i>d_b</i>	<i>D_a</i>	<i>D_b</i>	<i>r_a</i> max.	<i>r_b</i> max.	<i>Y₁</i>		<i>Y₀</i>	Inner ring	Outer ring	
HH221434 98350	HH221410 98788	42.5	120.0	105.0	171.0	179.0	7.9	3.2	0.33	1.79	0.99	5.57	2.21	
		54.5	118.0	112.0	174.0	188.0	3.6	3.2	0.63	0.95	0.52	5.27	2.28	
HM218248	HM218210	30.8	112.0	99.0	133.0	141.0	7.1	3.6	0.33	1.80	0.99	1.66	0.784	
JM718149 JHM318448 6581XR	JM718110 JHM318410 6535	32.7	105.0	99.0	131.0	139.0	3.0	2.5	0.44	1.35	0.74	1.47	0.652	
		34.5	106.0	100.0	140.0	148.0	3.0	2.5	0.34	1.76	0.97	2.37	1.00	
		41.0	102.0	98.0	141.0	154.0	3.0	3.2	0.40	1.50	0.82	3.02	1.65	
760	752	35.5	107.0	101.0	144.0	150.0	3.6	3.2	0.34	1.76	0.97	2.42	1.59	
47890R 681 681A 778 857R	47820 672 672 772 854	32.6	107.0	101.0	131.0	140.0	3.6	3.2	0.45	1.34	0.74	1.46	0.657	
		38.6	110.0	104.0	149.0	160.0	3.6	3.2	0.47	1.28	0.70	2.61	1.22	
		38.6	116.0	104.0	149.0	160.0	6.4	3.2	0.47	1.28	0.70	2.60	1.22	
		39.5	111.0	105.0	161.0	168.0	3.6	3.2	0.39	1.56	0.86	3.65	1.92	
		39.9	121.0	106.0	170.0	174.0	7.9	3.2	0.33	1.79	0.99	4.86	2.66	
JM719149	JM719113	33.5	109.0	104.0	135.0	143.0	3.0	2.5	0.44	1.36	0.75	1.43	0.766	
LL319349 L319249 47896R 594A 52375 683 864R HH221440	LL319310 L319210 47820 592XE 52618 672 854 HH221410	20.3	103.0	100.0	122.0	124.0	1.6	1.6	0.35	1.71	0.94	0.393	0.147	
		22.2	107.0	101.0	122.0	125.0	1.6	1.6	0.35	1.72	0.95	0.548	0.246	
		32.6	110.0	103.0	131.0	140.0	3.6	3.2	0.45	1.34	0.74	1.34	0.657	
		33.4	113.0	104.0	135.0	142.0	5.2	0.8	0.44	1.36	0.75	1.45	0.620	
		36.0	112.0	105.0	142.0	152.0	3.6	3.2	0.47	1.26	0.69	1.94	0.694	
		38.6	113.0	106.0	149.0	160.0	3.6	3.2	0.47	1.28	0.70	2.46	1.22	
		39.9	123.0	108.0	170.0	174.0	7.9	3.2	0.33	1.79	0.99	4.64	2.66	
42.5	125.0	110.0	171.0	179.0	7.9	3.2	0.33	1.79	0.99	5.16	2.21			
685 HH221442	672 HH221410	38.6	116.0	109.0	149.0	160.0	3.6	3.2	0.47	1.28	0.70	2.29	1.22	
		42.5	119.0	113.0	171.0	179.0	3.6	3.2	0.33	1.79	0.99	4.97	2.21	
HH224334	HH224310	47.6	122.0	117.0	192.0	202.0	3.6	3.2	0.33	1.84	1.01	7.91	3.03	

[Remark] Inch series tapered roller bearings with bore diameter larger than 100 mm are shown in catalog "large size ball & roller bearings".

Single-row tapered roller bearings inch series

d 99.982 ~ (107.950) mm

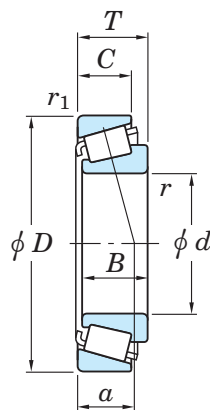

d	Boundary dimensions (mm)						Basic load ratings (kN)		Limiting speeds (min ⁻¹)	
	D	T	B	C	r min.	r_1 min.	C_r	C_{Or}	Grease lub.	Oil lub.
99.982	190.500	57.150	57.531	46.038	6.4	3.2	440	602	2 000	2 700
100.000	155.000	36.000	35.000	28.000	3.0	2.5	204	328	2 300	3 100
	160.000	41.000	40.000	32.000	3.0	2.5	237	378	2 300	3 000
100.012	157.162	36.512	36.116	26.195	3.6	3.2	180	288	2 300	3 000
101.600	157.162	36.512	36.116	26.195	3.6	3.2	180	288	2 300	3 000
	157.162	36.512	36.116	26.195	7.9	3.2	180	288	2 300	3 000
	168.275	41.275	41.275	30.162	3.6	3.2	224	349	2 200	3 000
	180.975	47.625	48.006	38.100	3.6	3.2	288	438	2 100	2 800
	190.500	57.150	57.531	44.450	7.9	3.2	385	565	2 100	2 700
	190.500	57.150	57.531	46.038	7.9	3.2	440	602	2 000	2 700
	200.000	52.761	49.212	34.925	3.6	3.2	347	471	1 400	1 900
	212.725	66.675	66.675	53.975	7.1	3.2	450	674	1 800	2 400
	212.725	66.675	66.675	53.975	7.1	3.2	513	699	1 800	2 400
104.775	180.975	47.625	48.006	38.100	3.6	3.2	288	438	2 100	2 800
	180.975	47.625	48.006	38.100	6.4	3.2	288	438	2 100	2 800
	180.975	47.625	48.006	38.100	7.1	3.2	288	438	2 100	2 800
	190.500	47.625	49.212	34.925	3.6	3.2	303	483	1 900	2 600
106.362	165.100	36.512	36.512	26.988	3.6	3.2	195	325	2 200	2 900
107.950	146.050	21.432	21.432	16.670	1.6	1.6	86.4	167	2 300	3 100
	158.750	23.020	21.438	15.875	3.6	3.2	104	169	2 200	3 000
	159.987	34.925	34.925	26.988	3.6	3.2	184	319	2 200	2 900
	161.925	34.925	34.925	26.988	3.6	3.2	173	293	2 200	2 900
	165.100	36.512	36.512	26.988	3.6	3.2	195	325	2 200	2 900
	168.275	36.512	36.512	26.988	3.6	3.2	195	325	2 200	2 900
	190.500	47.625	49.212	34.925	3.6	3.2	303	483	1 900	2 600

[Note] 1) To the bearings with supplementary code "J" attached at the front of bearing number, tolerances shown in table 7-8 on page A66 are applied.

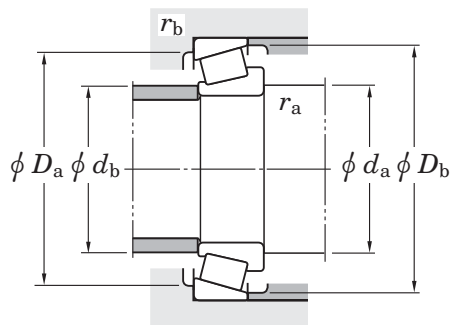

Bearing No. ¹⁾		Load center (mm) <i>a</i>	Mounting dimensions (mm)							Constant <i>e</i>	Axial load factors		(Refer.) Mass (kg)	
Inner ring	Outer ring		<i>d_a</i>	<i>d_b</i>	<i>D_a</i>	<i>D_b</i>	<i>r_a</i> max.	<i>r_b</i> max.	<i>Y₁</i>		<i>Y₀</i>	Inner ring	Outer ring	
HH221447	HH221410	42.5	126.0	114.0	171.0	179.0	6.4	3.2	0.33	1.79	0.99	4.84	2.21	
JM720249	JM720210	35.6	110.0	110.0	139.0	148.0	3.0	2.5	0.47	1.27	0.70	1.64	0.763	
JHM720249	JHM720210	38.3	110.0	111.0	143.0	153.0	3.0	2.5	0.47	1.28	0.70	2.11	0.964	
52393	52618	36.0	113.0	115.0	142.0	150.0	3.6	3.2	0.47	1.26	0.69	1.74	0.694	
52400	52618	36.0	114.0	115.0	142.0	150.0	3.6	3.2	0.47	1.26	0.69	1.67	0.694	
52401	52618	36.0	126.0	111.0	142.0	152.0	7.9	3.2	0.47	1.26	0.69	1.64	0.694	
687	672	38.6	114.0	115.0	146.0	156.0	3.6	3.2	0.47	1.28	0.70	2.15	1.22	
780	772	39.5	114.0	120.0	156.0	165.0	3.6	3.2	0.39	1.56	0.86	3.09	1.92	
861R	854	39.9	129.0	114.0	170.0	174.0	7.9	3.2	0.33	1.79	0.99	4.20	2.66	
HH221449	HH221410	42.5	123.0	119.0	168.0	178.0	7.9	3.2	0.33	1.79	0.99	4.72	2.21	
98400	98788	54.5	114.0	123.0	170.0	185.0	3.6	3.2	0.63	0.95	0.52	4.55	2.28	
941	932	47.6	121.0	135.0	181.0	192.0	7.1	3.2	0.33	1.84	1.01	7.07	4.07	
HH224335	HH224310	47.6	121.0	134.0	189.0	201.0	7.1	3.2	0.33	1.84	1.01	7.76	3.03	
782	772	39.5	117.0	120.0	156.0	165.0	3.6	3.2	0.39	1.56	0.86	2.90	1.92	
786	772	39.5	123.0	120.0	156.0	165.0	6.4	3.2	0.39	1.56	0.86	2.88	1.92	
787	772	39.5	129.0	116.0	161.0	168.0	7.1	3.2	0.39	1.56	0.86	2.87	1.92	
71412	71750	40.9	117.0	131.0	167.0	177.0	3.6	3.2	0.42	1.44	0.79	3.96	1.72	
56418R	56650	38.6	122.0	116.0	149.0	159.0	3.6	3.2	0.50	1.21	0.66	1.84	0.852	
L521949R	L521910	26.2	116.0	114.0	136.0	141.0	1.6	1.6	0.39	1.53	0.84	0.665	0.325	
37425	37625	36.5	121.0	121.0	141.0	148.0	3.6	3.2	0.61	0.99	0.54	0.893	0.484	
LM522546	LM522510	32.9	122.0	116.0	146.0	154.0	3.6	3.2	0.40	1.50	0.82	1.64	0.784	
48190	48120	39.1	121.0	120.0	145.0	154.0	3.6	3.2	0.51	1.19	0.65	1.57	0.820	
56425R	56650	38.6	123.0	117.0	149.0	159.0	3.6	3.2	0.50	1.21	0.66	1.76	0.852	
56425R	56662	38.6	123.0	117.0	150.0	160.0	3.6	3.2	0.50	1.21	0.66	1.76	1.03	
71425	71750	40.9	121.0	131.0	167.0	177.0	3.6	3.2	0.42	1.44	0.79	3.76	1.72	

[Remark] Inch series tapered roller bearings with bore diameter larger than 100 mm are shown in catalog "large size ball & roller bearings".

Single-row tapered roller bearings inch series

d (107.950) ~ 127.000 mm

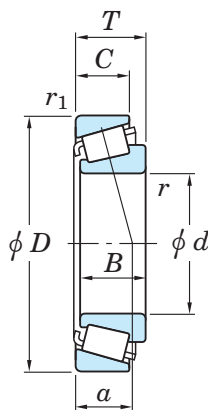

d	Boundary dimensions (mm)						Basic load ratings (kN)		Limiting speeds (min ⁻¹)	
	D	T	B	C	r min.	r_1 min.	C_r	C_{0r}	Grease lub.	Oil lub.
107.950	212.725	66.675	66.675	53.975	7.9	3.2	450	674	1 800	2 400
	212.725	66.675	66.675	53.975	7.9	3.2	513	699	1 800	2 400
109.538	158.750	23.020	21.438	15.875	6.4	6.4	104	169	2 200	3 000
109.987	159.987	34.925	34.925	26.988	7.9	3.2	184	319	2 200	2 900
	159.987	34.925	34.925	26.988	3.6	3.2	184	319	2 200	2 900
109.992	177.800	41.275	41.275	30.162	3.6	3.2	234	380	2 000	2 700
110.000	165.000	35.000	35.000	26.500	3.0	2.5	195	325	2 200	2 900
	180.000	47.000	46.000	38.000	3.0	2.5	306	487	2 000	2 700
114.300	177.800	41.275	41.275	30.162	3.6	3.2	234	380	2 000	2 700
	180.975	34.925	31.750	25.400	3.6	3.2	171	247	2 000	2 700
	190.500	47.625	49.212	34.925	3.6	3.2	303	483	1 900	2 600
	212.725	66.675	66.675	53.975	7.1	3.2	450	674	1 800	2 400
	212.725	66.675	66.675	53.975	7.1	3.2	513	699	1 800	2 400
	273.050	82.550	82.550	53.975	6.4	6.4	707	898	1 500	1 900
114.976	212.725	66.675	66.675	53.975	7.1	3.2	513	699	1 800	2 400
115.087	190.500	47.625	49.212	34.925	3.6	3.2	303	483	1 900	2 600
	190.500	47.625	49.212	34.925	7.9	3.2	303	483	1 900	2 600
117.475	180.975	34.925	31.750	25.400	3.6	3.2	171	247	2 000	2 700
	180.975	34.925	31.750	25.400	7.9	3.2	171	247	2 000	2 700
120.650	190.500	46.038	46.038	34.925	3.6	1.6	313	512	1 900	2 500
	254.000	77.788	82.550	61.912	9.5	6.4	717	1 050	1 500	2 000
127.000	254.000	77.788	82.550	61.912	9.5	6.4	717	1 050	1 500	2 000

[Note] 1) To the bearings with supplementary code "J" attached at the front of bearing number, tolerances shown in table 7-8 on page A66 are applied.

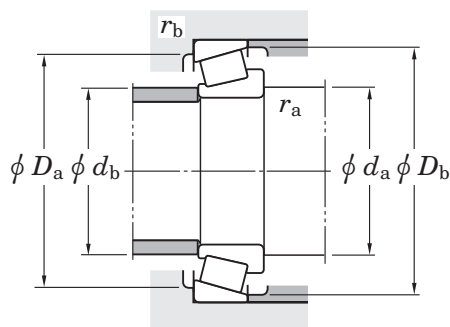

	Bearing No. ¹⁾		Load center (mm) <i>a</i>	Mounting dimensions (mm)						Con- stant <i>e</i>	Axial load factors		(Refer.) Mass (kg)	
	Inner ring	Outer ring		<i>d_a</i>	<i>d_b</i>	<i>D_a</i>	<i>D_b</i>	<i>r_a</i> max.	<i>r_b</i> max.		<i>Y₁</i>	<i>Y₀</i>	Inner ring	Outer ring
	936	932	47.6	137.0	122.0	187.0	193.0	7.9	3.2	0.33	1.84	1.01	6.52	4.07
	HH224340	HH224310	47.6	129.0	134.0	189.0	201.0	7.9	3.2	0.33	1.84	1.01	7.21	3.03
	37431	37625	36.5	123.0	116.0	143.0	152.0	6.4	6.4	0.61	0.99	0.54	0.848	0.484
	LM522548	LM522510	32.9	131.0	121.0	146.0	153.0	7.9	3.2	0.40	1.50	0.82	1.52	0.784
	LM522549	LM522510	32.9	123.0	121.0	146.0	153.0	3.6	3.2	0.40	1.50	0.82	1.55	0.784
	64433R	64700	42.8	128.0	121.0	160.0	172.6	3.6	3.2	0.52	1.16	0.64	2.69	1.10
	JM822049	JM822010	38.1	121.0	121.0	148.0	157.0	3.0	2.5	0.50	1.21	0.66	1.64	0.826
	JHM522649	JHM522610	40.6	121.0	125.0	160.0	171.0	3.0	2.5	0.41	1.48	0.81	3.08	1.49
	64450R	64700	42.8	131.0	125.0	160.0	172.0	3.6	3.2	0.52	1.16	0.64	2.45	1.10
	68450	68712	40.6	127.0	131.0	161.0	169.0	3.6	3.2	0.50	1.21	0.66	1.89	1.04
	71450	71750	40.9	127.0	131.0	167.0	177.0	3.6	3.2	0.42	1.44	0.79	3.33	1.72
	938	932	47.6	141.0	128.0	187.0	193.0	7.1	3.2	0.33	1.84	1.01	5.96	4.07
	HH224346	HH224310	47.6	134.0	134.0	189.0	201.0	7.1	3.2	0.33	1.84	1.01	6.64	3.03
	HH926744	HH926710	76.1	133.0	151.0	230.0	252.0	6.4	6.4	0.63	0.95	0.52	15.0	6.97
	HH224349	HH224310	47.6	135.0	134.0	189.0	201.0	7.1	3.2	0.33	1.84	1.01	6.58	3.03
	71453	71750	40.9	133.0	126.0	171.0	181.0	3.6	3.2	0.42	1.44	0.79	3.28	1.72
	71455	71750	40.9	136.0	131.0	167.0	177.0	7.9	3.2	0.42	1.44	0.79	3.25	1.72
	68462	68712	40.6	130.0	131.0	161.0	169.0	3.6	3.2	0.50	1.21	0.66	1.75	1.04
	68463	68712	40.6	141.0	125.0	163.0	172.0	7.9	3.2	0.50	1.21	0.66	1.61	1.05
	HM624749	HM624710	41.6	146.0	132.0	174.0	184.0	3.6	1.6	0.43	1.41	0.77	3.20	1.44
	HH228340	HH228310	54.3	158.0	142.0	223.0	234.0	9.5	6.4	0.32	1.87	1.03	12.6	6.00
	HH228349	HH228310	54.3	164.0	148.0	223.0	234.0	9.5	6.4	0.32	1.87	1.03	11.8	6.00

[Remark] Inch series tapered roller bearings with bore diameter larger than 100 mm are shown in catalog "large size ball & roller bearings".

Single-row tapered roller bearings inch series

d 133.350 ~ 292.100 mm

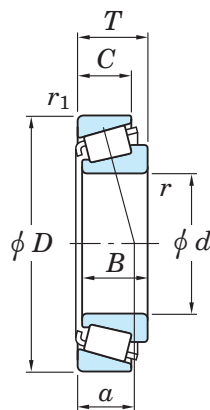

d	Boundary dimensions (mm)						Basic load ratings (kN)		Limiting speeds (min ⁻¹)	
	D	T	B	C	r min.	r_1 min.	C_r	C_{Or}	Grease lub.	Oil lub.
133.350	177.008	25.400	26.195	20.638	1.6	1.6	141	278	1 900	2 500
142.875	200.025	41.275	39.688	34.130	7.9	3.3	246	491	1 700	2 200
	200.025	41.275	39.688	34.130	3.6	3.3	246	491	1 700	2 200
170.000	230.000	39.000	38.000	31.000	3.0	2.5	291	558	1 400	1 900
	240.000	46.000	44.500	37.000	3.0	2.5	353	666	1 400	1 800
171.450	222.250	25.400	24.608	19.050	1.6	1.6	157	299	1 400	1 900
180.000	250.000	47.000	45.000	37.000	3.0	2.5	365	705	1 300	1 700
190.000	260.000	46.000	44.000	36.500	3.0	2.5	369	723	1 200	1 700
196.850	254.000	28.575	27.783	21.433	1.6	1.6	188	387	1 200	1 600
200.000	300.000	65.000	62.000	51.000	3.6	2.5	617	1 140	1 100	1 500
220.878	317.500	47.625	52.388	36.513	3.2	3.2	488	928	970	1 300
228.600	358.775	71.438	71.438	53.975	3.6	3.2	773	1 590	840	1 100
230.188	317.500	47.625	52.388	36.513	3.2	3.2	488	928	970	1 300
231.775	317.500	47.625	52.388	36.513	3.2	3.2	488	928	970	1 300
	336.550	65.088	65.088	50.800	6.4	3.2	708	1 380	920	1 200
	358.775	71.438	71.438	53.975	6.4	3.2	773	1 590	920	1 200
254.000	358.775	71.438	71.438	53.975	3.6	3.2	773	1 590	840	1 100
257.175	342.900	57.150	57.150	44.450	6.4	3.2	612	1 280	870	1 200
292.100	374.650	47.625	47.625	34.925	3.6	3.2	468	971	760	1 000

[Note] 1) To the bearings with supplementary code "J" attached at the front of bearing number, tolerances shown in table 7-8 on page A66 are applied.

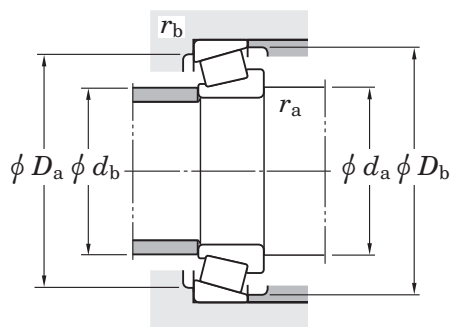

	Bearing No. ¹⁾		Load center (mm) a	Mounting dimensions (mm)						Constant e	Axial load factors		(Refer.) Mass (kg)	
	Inner ring	Outer ring		d_a	d_b	D_a	D_b	r_a max.	r_b max.		Y_1	Y_0	Inner ring	Outer ring
	L327249	L327210	29.1	142.0	145.0	164.0	169.0	1.6	1.6	0.35	1.72	0.95	1.14	0.543
	48684	48620	38.4	166.0	151.0	185.0	193.0	7.9	3.3	0.34	1.78	0.98	2.43	1.38
	48685	48620	38.4	156.0	157.0	182.0	190.0	3.6	3.3	0.34	1.78	0.98	2.46	1.38
	JHM534149	JHM534110	43.6	181.0	184.0	214.0	222.0	3.0	2.5	0.38	1.57	0.86	3.17	1.29
	JM734449	JM734410	50.6	181.0	184.0	220.0	231.0	3.0	2.5	0.44	1.37	0.75	4.31	2.00
	L435049	L435010	36.0	181.0	179.0	211.0	215.0	1.6	1.6	0.38	1.60	0.88	1.63	0.697
	JM736149	JM736110	55.2	191.0	193.0	230.0	242.0	3.0	2.5	0.48	1.25	0.69	4.47	2.10
	JM738249	JM738210	56.0	201.0	203.0	240.0	251.0	3.0	2.5	0.48	1.26	0.69	4.71	2.18
	L540049	L540010	43.1	206.0	214.0	238.0	243.0	1.6	1.6	0.40	1.51	0.83	2.34	1.02
	JHM840449	JHM840410	72.1	213.0	218.0	270.0	288.0	3.6	2.5	0.52	1.15	0.63	9.97	5.13
	LM245833	LM245810	50.5	234.0	253.0	296.0	304.0	3.2	3.2	0.33	1.80	0.99	9.56	2.78
	M249732	M249710	64.4	242.0	279.0	330.0	342.0	3.6	3.2	0.33	1.80	0.99	20.1	6.44
	LM245846	LM245810	50.5	242.0	238.0	309.0	312.0	3.2	3.2	0.33	1.80	0.99	8.25	2.78
	LM245848	LM245810	50.5	244.0	240.0	309.0	312.0	3.2	3.2	0.33	1.80	0.99	8.02	2.78
	M246942	M246910	59.9	258.0	249.0	313.0	322.0	6.4	3.2	0.33	1.80	0.99	13.1	5.44
	M249734	M249710	64.4	258.0	253.0	335.0	343.0	6.4	3.2	0.33	1.80	0.99	19.9	6.44
	M249749	M249710	64.4	268.0	279.0	330.0	342.0	3.6	3.2	0.33	1.80	0.99	14.8	6.44
	M349549	M349510	60.1	276.0	276.0	320.0	330.0	6.4	3.2	0.35	1.73	0.95	9.27	3.99
	L555249	L555210	64.7	306.0	309.0	351.0	360.0	3.6	3.2	0.40	1.49	0.82	7.97	3.53

[Remark] Inch series tapered roller bearings with bore diameter larger than 100 mm are shown in catalog "large size ball & roller bearings".

Double-row tapered roller bearings

TDO type

d 25 ~ (60) mm

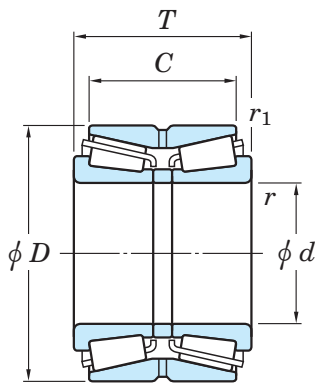

Boundary dimensions (mm)						Basic load ratings (kN)		Limiting speeds (min ⁻¹)		
d	D	T	C	r min.	r_1 min.	C_R	C_{0r}	Grease lub.	Oil lub.	
25	62	40	29.5	1.5	0.6	68.3	84.9	4 500	6 400	
30	72	45	31.5	1.5	0.6	87.3	110	3 900	5 400	
35	80	51	35.5	2	0.6	108	138	3 400	4 800	
40	80	45	37.5	1.5	0.6	108	138	4 000	5 300	
	80	55	43.5	1.5	0.6	133	182	4 000	5 300	
	90	56	39.5	2	0.6	138	180	3 000	4 200	
	90	56	45.5	2	0.6	155	202	3 600	4 900	
45	85	47	37.5	1.5	0.6	115	155	3 700	4 900	
	85	55	43.5	1.5	0.6	144	207	3 700	4 900	
	100	60	41.5	2	0.6	163	214	2 700	3 800	
	100	60	49.5	2	0.6	193	256	3 300	4 300	
50	90	49	39.5	1.5	0.6	131	183	3 400	4 600	
	90	55	43.5	1.5	0.6	146	211	3 500	4 600	
	110	64	51.5	2	0.6	236	305	3 000	4 000	
	110	73	52.5	2	0.6	198	266	2 500	3 500	
	110	90	71.5	2	0.6	302	440	3 000	4 000	
55	100	51	41.5	2	0.6	162	226	3 100	4 100	
	100	60	48.5	2	0.6	184	266	3 100	4 100	
	120	70	49	2	0.6	221	297	2 300	3 200	
	120	70	57	2	0.6	256	341	2 700	3 600	
	120	97	76	2	0.6	343	500	2 700	3 600	
60	110	53	43.5	2	0.6	182	254	2 800	3 800	
	110	66	54.5	2	0.6	226	334	2 800	3 800	
	130	74	51	2.5	1	262	359	2 100	2 900	
	130	74	59	2.5	1	297	401	2 500	3 300	

[Remark] Bearings not shown above (e.g. inch series) are shown in catalog "large size ball & roller bearings".

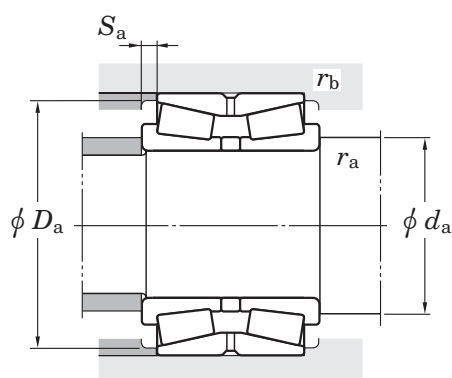

Bearing No.	Mounting dimensions (mm)					Constant <i>e</i>	Axial load factors			(Refer.) Mass (kg)
	<i>d_a</i> min.	<i>D_a</i> min.	<i>S_a</i> min.	<i>r_a</i> max.	<i>r_b</i> max.		<i>Y₂</i>	<i>Y₃</i>	<i>Y₀</i>	
46T30305DJR/29.5	33.5	58.5	5	1.5	0.6	0.83	0.82	1.22	0.8	0.592
46T30306DJR/31.5	38.5	68	6.5	1.5	0.6	0.83	0.82	1.22	0.8	0.872
46T30307DJR/35.5	45	76.5	7.5	2	0.6	0.83	0.82	1.22	0.8	1.2
46T30208JR/37.5	48.5	75	3.5	1.5	0.6	0.37	1.8	2.68	1.76	0.954
46T32208JR/43.5	48.5	75	5.5	1.5	0.6	0.37	1.8	2.68	1.76	1.19
46T30308DJR/39.5	50	86.5	8	2	0.6	0.83	0.82	1.22	0.8	1.67
46T30308JR/45.5	50	82	5	2	0.6	0.35	1.96	2.91	1.91	1.67
46T30209JR/37.5	53.5	80	4.5	1.5	0.6	0.4	1.67	2.48	1.63	1.1
46T32209JR-1/43.5	53.5	81	5.5	1.5	0.6	0.4	1.67	2.48	1.63	1.31
46T30309DJR/41.5	55	96	9	2	0.6	0.83	0.82	1.22	0.8	2.15
46T30309JR/49.5	55	93	5	2	0.6	0.35	1.96	2.91	1.91	2.2
46T30210JR/39.5	58.5	85	4.5	1.5	0.6	0.42	1.61	2.39	1.57	1.22
46T32210JR/43.5	58.5	85	5.5	1.5	0.6	0.42	1.61	2.39	1.57	1.39
46T30310JR/51.5	62	102	6	2	0.6	0.35	1.96	2.91	1.91	2.68
46T30310DJR/52.5	62	105	10	2	0.6	0.83	0.82	1.22	0.8	3.11
46T32310JR/71.5	62	102	9	2	0.6	0.35	1.96	2.91	1.91	3.95
46T30211JR/41.5	65	94	4.5	2	0.6	0.4	1.67	2.48	1.63	1.6
46T32211JR-1/48.5	65	95	5.5	2	0.6	0.4	1.67	2.48	1.63	1.87
46T30311DJR/49	67	113	10.5	2	0.6	0.83	0.82	1.22	0.8	3.54
46T30311JR/57	67	111	6.5	2	0.6	0.35	1.96	2.91	1.91	3.57
46T32311JR/76	67	111	10.5	2	0.6	0.35	1.96	2.91	1.91	4.98
46T30212JR/43.5	70	103	4.5	2	0.6	0.4	1.67	2.48	1.63	2.04
46T32212JR/54.5	70	104	5.5	2	0.6	0.4	1.67	2.48	1.63	—
46T30312DJR/51	74	124	11.5	2.5	1	0.83	0.82	1.22	0.8	4.45
46T30312JR/59	74	120	7.5	2.5	1	0.35	1.96	2.91	1.91	4.46

Double-row tapered roller bearings

TDO type

d (60) ~ (90) mm

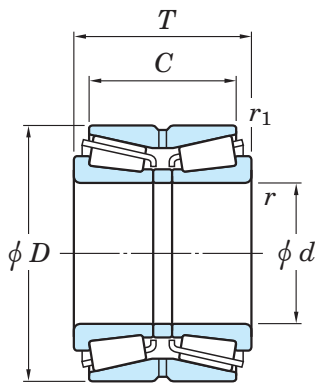

Boundary dimensions (mm)						Basic load ratings (kN)		Limiting speeds (min ⁻¹)		
d	D	T	C	r min.	r_1 min.	C_R	C_{0r}	Grease lub.	Oil lub.	
60	130	104	81	2.5	1	419	629	2 500	3 300	
65	120	56	46.5	2	0.6	220	311	2 600	3 400	
	120	73	61.5	2	0.6	270	406	2 600	3 400	
	140	79	53	2.5	1	302	417	1 900	2 700	
	140	79	63	2.5	1	349	478	2 300	3 000	
	140	108	84	2.5	1	474	714	2 300	3 100	
70	125	59	48.5	2	0.6	236	346	2 400	3 300	
	125	74	61.5	2	0.6	290	450	2 400	3 300	
	150	83	57	2.5	1	338	470	1 800	2 500	
	150	83	67	2.5	1	394	546	2 100	2 800	
	150	116	92	2.5	1	543	829	2 200	2 900	
75	115	30	26	1.5	0.6	71.7	105	2 500	3 300	
	115	38	30	1.5	0.6	122	207	2 500	3 300	
	130	62	51.5	2	0.6	244	362	2 300	3 100	
	130	74	61.5	2	0.6	298	469	2 300	3 100	
	160	87	69	2.5	1	445	621	2 000	2 600	
	160	125	99	2.5	1	622	963	2 000	2 700	
80	125	34	30	1.5	0.6	108	155	2 300	3 100	
	140	64	51.5	2	0.6	277	405	2 200	2 900	
	140	78	63.5	2	0.6	347	542	2 200	2 900	
	170	92	73	2.5	1	504	711	1 800	2 500	
85	150	70	57	2	0.6	313	463	2 000	2 700	
	150	86	69	2	0.6	398	630	2 000	2 700	
	180	98	77	3	1	543	768	1 700	2 300	
	180	137	108	3	1	752	1 170	1 800	2 400	
90	140	37	33	2	0.6	136	199	2 100	2 800	

[Remark] Bearings not shown above (e.g. inch series) are shown in catalog "large size ball & roller bearings".

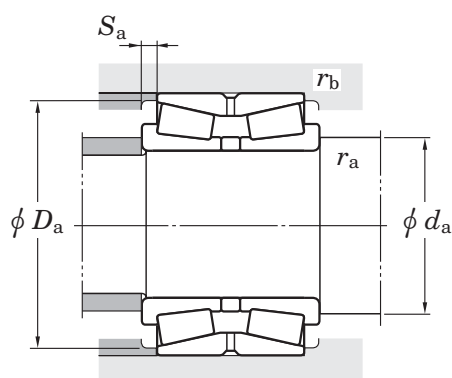

Bearing No.	Mounting dimensions (mm)					Con- stant <i>e</i>	Axial load factors			(Refer.) Mass (kg)
	<i>d_a</i> min.	<i>D_a</i> min.	<i>S_a</i> min.	<i>r_a</i> max.	<i>r_b</i> max.		<i>Y₂</i>	<i>Y₃</i>	<i>Y₀</i>	
46T32312JR/81	74	120	11.5	2.5	1	0.35	1.96	2.91	1.91	6.45
46T30213JR/46.5	75	113	4.5	2	0.6	0.4	1.67	2.48	1.63	—
46T32213JR/61.5	75	115	5.5	2	0.6	0.4	1.67	2.48	1.63	3.4
46T30313DJR/53	79	133	13	2.5	1	0.83	0.82	1.22	0.8	5.3
46T30313JR/63	79	130	8	2.5	1	0.35	1.96	2.91	1.91	5.51
46T32313JR/84	79	130	12	2.5	1	0.35	1.96	2.91	1.91	7.71
46T30214JR/48.5	80	118	5	2	0.6	0.42	1.61	2.39	1.57	—
46T32214JR/61.5	80	119	6	2	0.6	0.42	1.61	2.39	1.57	3.7
46T30314DJR/57	84	142	13	2.5	1	0.83	0.82	1.22	0.8	6.48
46T30314JR/67	84	140	8	2.5	1	0.35	1.96	2.91	1.91	6.65
46T32314JR/92	84	140	12	2.5	1	0.35	1.96	2.91	1.91	9.46
46215	83.5	106.5	2	1.5	0.6	0.32	2.12	3.15	2.07	0.994
46215A	83.5	107.4	4	1.5	0.6	0.32	2.12	3.15	2.07	1.32
46T30215JR/51.5	85	124	5	2	0.6	0.44	1.55	2.31	1.52	3.12
46T32215JR/61.5	85	125	6	2	0.6	0.44	1.55	2.31	1.52	3.85
46T30315JR/69	89	149	9	2.5	1	0.35	1.96	2.91	1.91	7.8
46T32315JR/99	89	149	13	2.5	1	0.35	1.96	2.91	1.91	11.5
46216	88.5	116.9	2	1.5	0.6	0.35	1.95	2.90	1.91	1.38
46T30216JR/51.5	92	132	6	2	0.6	0.42	1.61	2.39	1.57	3.76
46T32216JR/63.5	92	134	7	2	0.6	0.42	1.61	2.39	1.57	4.71
46T30316JR/73	94	159	9.5	2.5	1	0.35	1.96	2.91	1.91	9.44
46T30217JR/57	97	141	6.5	2	0.6	0.42	1.61	2.39	1.57	4.79
46T32217JR/69	97	142	8.5	2	0.6	0.42	1.61	2.39	1.57	6.05
46T30317JR/77	103	167	10.5	3	1	0.35	1.96	2.91	1.91	11
46T32317JR/108	103	167	14.5	3	1	0.35	1.96	2.91	1.91	16
46218	100	130.6	2	2	0.6	0.35	1.95	2.90	1.91	1.89

Double-row tapered roller bearings

TDO type

d (90) ~ 110 mm

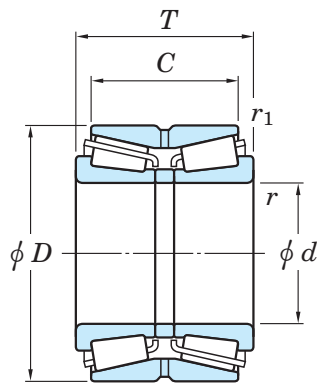

d	Boundary dimensions (mm)					Basic load ratings (kN)		Limiting speeds (min^{-1})	
	D	T	C	r min.	r_1 min.	C_R	C_{0r}	Grease lub.	Oil lub.
90	140	46	37	2	0.6	157	266	2 000	2 700
	160	74	61	2	0.6	350	522	1 900	2 500
	160	94	77	2	0.6	451	724	1 900	2 500
	190	102	81	3	1	592	841	1 600	2 200
	190	144	115	3	1	791	1 230	1 700	2 200
95	170	78	63	2.5	1	396	598	1 800	2 400
	170	100	83	2.5	1	533	877	1 800	2 400
	200	108	85	3	1	638	909	1 600	2 100
	200	151	118	3	1	886	1 390	1 600	2 100
100	150	46	37	2	0.6	180	293	1 900	2 500
	165	52	46	2.5	0.6	198	305	1 700	2 300
	165	65	52	2.5	0.6	265	443	1 800	2 300
	180	83	67	2.5	1	443	676	1 700	2 200
	180	107	87	2.5	1	596	990	1 700	2 200
	215	112	87	3	1	724	1 040	1 500	1 900
	215	162	127	3	1	993	1 570	1 500	2 000
105	190	88	70	2.5	1	494	761	1 600	2 100
	190	115	95	2.5	1	672	1 130	1 600	2 100
	225	116	91	3	1	796	1 160	1 400	1 800
	225	170	133	3	1	1 090	1 730	1 400	1 900
110	170	45	40	2.5	0.6	175	304	1 700	2 200
	180	56	50	2.5	0.6	245	388	1 600	2 100
	180	70	56	2.5	0.6	324	533	1 600	2 100
	200	92	74	2.5	1	556	868	1 500	2 000
	200	121	101	2.5	1	750	1 280	1 500	2 000
	240	118	93	3	1	824	1 180	1 300	1 700
	240	181	142	3	1	1 190	1 890	1 300	1 700

[Remark] Bearings not shown above (e.g. inch series) are shown in catalog "large size ball & roller bearings".

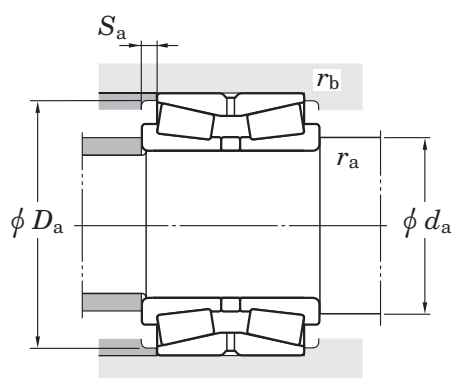

Bearing No.	Mounting dimensions (mm)					Constant <i>e</i>	Axial load factors			(Refer.) Mass (kg)
	<i>d_a</i> min.	<i>D_a</i> min.	<i>S_a</i> min.	<i>r_a</i> max.	<i>r_b</i> max.		<i>Y₂</i>	<i>Y₃</i>	<i>Y₀</i>	
46218A	100	129.9	4.5	2	0.6	0.32	2.12	3.15	2.07	2.37
46T30218JR/61	102	150	6.5	2	0.6	0.42	1.61	2.39	1.57	5.85
46T32218JR/77	102	152	8.5	2	0.6	0.42	1.61	2.39	1.57	7.53
46T30318JR/81	108	177	10.5	3	1	0.35	1.96	2.91	1.91	13
46T32318JR/115	108	177	14.5	3	1	0.35	1.96	2.91	1.91	18.6
46T30219JR/63	109	159	7.5	2.5	1	0.42	1.61	2.39	1.57	7.01
46T32219JR/83	109	161	8.5	2.5	1	0.42	1.61	2.39	1.57	9.25
46T30319JR/85	113	186	11.5	3	1	0.35	1.96	2.91	1.91	14.8
46T32319JR/118	113	186	16.5	3	1	0.35	1.96	2.91	1.91	21.4
46220A	110	142	4.5	2	0.6	0.35	1.95	2.90	1.91	2.53
46320	112	154	3	2	0.6	0.35	1.95	2.90	1.91	4.03
46320A	112	153	6.5	2	0.6	0.35	1.95	2.90	1.91	4.97
46T30220JR/67	114	168	8	2.5	1	0.42	1.61	2.39	1.57	8.33
46T32220JR/87	114	171	10	2.5	1	0.42	1.61	2.39	1.57	11.1
46T30320JR/87	118	200	12.5	3	1	0.35	1.96	2.91	1.91	18.1
46T32320JR/127	118	200	17.5	3	1	0.35	1.96	2.91	1.91	27.2
46T30221JR/70	119	178	9	2.5	1	0.42	1.61	2.39	1.57	9.87
46T32221JR/95	119	180	10	2.5	1	0.42	1.61	2.39	1.57	13.5
46T30321JR/91	123	209	12.5	3	1	0.35	1.96	2.91	1.91	20.7
46T32321JR/133	123	209	18.5	3	1	0.35	1.96	2.91	1.91	30.9
46222	122	158	2.5	2	0.6	0.35	1.95	2.90	1.91	3.58
46322	122	168	3	2	0.6	0.35	1.95	2.90	1.91	5.13
46322A	122	168	7	2	0.6	0.35	1.92	2.86	1.88	6.43
46T30222JR/74	124	188	9	2.5	1	0.42	1.61	2.39	1.57	11.6
46T32222JR/101	124	190	10	2.5	1	0.42	1.61	2.39	1.57	15.9
46T30322JR/93	128	222	12.5	3	1	0.35	1.96	2.91	1.91	23.8
46T32322JR/142	128	222	19.5	3	1	0.35	1.96	2.91	1.91	37.3

Double-row tapered roller bearings

TDO type

d 120 ~ (150) mm

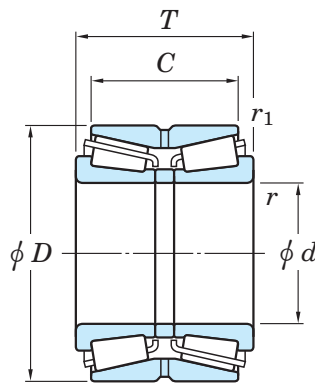

d	Boundary dimensions (mm)					Basic load ratings (kN)		Limiting speeds (min ⁻¹)	
	D	T	C	r min.	r_1 min.	C_R	C_{0r}	Grease lub.	Oil lub.
120	180	46	41	2.5	0.6	185	317	1 500	2 000
	180	58	46	2.5	0.6	247	460	1 500	2 100
	200	62	55	2.5	0.6	292	470	1 400	1 900
	200	78	62	2.5	0.6	387	672	1 400	1 900
	200	100	84	2.5	0.6	533	1 010	1 400	1 900
	215	97	78	2.5	1	595	945	1 400	1 800
	215	132	109	2.5	1	806	1 380	1 400	1 900
	260	128	101	3	1	976	1 430	1 200	1 600
260	188	145	4	1.5	1 370	2 210	1 200	1 600	
130	200	52	46	2.5	0.6	239	425	1 400	1 800
	200	65	52	2.5	0.6	319	618	1 400	1 900
	210	64	57	2.5	0.6	322	535	1 400	1 800
	210	80	64	2.5	0.6	424	723	1 300	1 800
	230	98	78.5	3	1	646	1 020	1 300	1 700
	230	145	117.5	3	1	949	1 660	1 300	1 700
	280	137	107.5	4	1.5	1 130	1 670	1 100	1 400
140	210	53	47	2.5	0.6	239	404	1 300	1 800
	210	66	53	2.5	0.6	360	639	1 300	1 800
	225	68	61	3	1	360	564	1 200	1 700
	225	85	68	3	1	475	836	1 200	1 700
	250	102	82.5	3	1	720	1 140	1 200	1 500
	250	153	125.5	3	1	1 090	1 920	1 200	1 600
	300	145	115.5	4	1.5	1 280	1 920	1 000	1 300
150	225	56	50	3	1	278	476	1 200	1 600
	225	70	56	3	1	377	703	1 200	1 600
	250	80	71	3	1	467	786	1 100	1 500
	250	100	80	3	1	595	1 070	1 100	1 500
	270	109	87	3	1	827	1 330	1 100	1 400

[Remark] Bearings not shown above (e.g. inch series) are shown in catalog "large size ball & roller bearings".

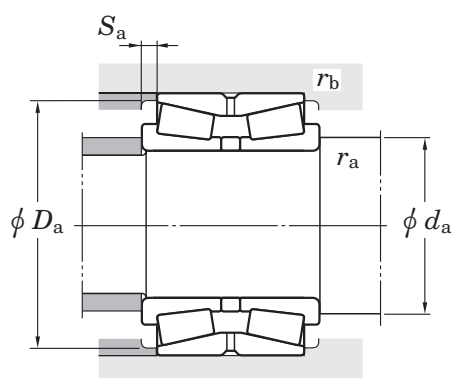

Bearing No.	Mounting dimensions (mm)					Con-stant <i>e</i>	Axial load factors			(Refer.) Mass (kg)
	<i>d_a</i> min.	<i>D_a</i> min.	<i>S_a</i> min.	<i>r_a</i> max.	<i>r_b</i> max.		<i>Y₂</i>	<i>Y₃</i>	<i>Y₀</i>	
46224	132	170	2.5	2	0.6	0.35	1.95	2.90	1.91	3.81
46224A	132	169	6	2	0.6	0.35	1.95	2.90	1.91	4.66
46324	132	184	3.5	2	0.6	0.35	1.95	2.90	1.91	7.28
46324A	132	185	8	2	0.6	0.35	1.95	2.90	1.91	9.14
46324AS	132	190	8	2	0.6	0.35	1.95	2.90	1.91	12.0
46T30224JR/78	134	203	9.5	2.5	1	0.44	1.55	2.31	1.52	13.9
46T32224JR/109	134	204	11.5	2.5	1	0.44	1.55	2.31	1.52	19.8
46T30324JR/101	138	239	13.5	3	1	0.35	1.96	2.91	1.91	30.6
46T32324JR/145	142	239	21.5	4	1.5	0.35	1.96	2.91	1.91	45.9
46226	142	187	3	2	0.6	0.35	1.95	2.90	1.91	5.57
46226A	142	185	6.5	2	0.6	0.35	1.95	2.90	1.91	7.06
46326	142	196	3.5	2	0.6	0.36	1.87	2.79	1.83	7.81
46326A	142	198	8	2	0.6	0.36	1.87	2.79	1.83	9.57
46T30226JR/78.5	148	218	9.5	3	1	0.44	1.55	2.31	1.52	15.7
46T32226JR/117.5	148	219	14	3	1	0.44	1.55	2.31	1.52	24.1
46T30326JR/107.5	152	255	15	4	1.5	0.35	1.96	2.91	1.91	38.1
46228	152	196	3	2	0.6	0.33	2.03	3.02	1.98	5.85
46228A	152	199	6.5	2	0.6	0.47	1.43	2.12	1.40	7.18
46328	154	210	3.5	2.5	1	0.35	1.95	2.90	1.91	9.56
46328A	154	212	8	2.5	1	0.35	1.95	2.90	1.91	11.8
46T30228JR/82.5	158	237	9.5	3	1	0.44	1.55	2.31	1.52	19.7
46T32228JR/125.5	158	238	14	3	1	0.44	1.55	2.31	1.52	30.2
46T30328JR/115.5	162	273	15	4	1.5	0.35	1.96	2.91	1.91	46.6
46230	164	213	3	2.5	1	0.33	2.03	3.02	1.98	7.09
46230A	164	213	7	2.5	1	0.33	2.03	3.02	1.98	8.82
46330	164	233	4.5	2.5	1	0.35	1.95	2.90	1.91	14.6
46330A	164	234	10	2.5	1	0.35	1.95	2.90	1.91	17.6
46T30230JR/87	168	255	11	3	1	0.44	1.55	2.31	1.52	24.6

Double-row tapered roller bearings

TDO type

d (150) ~ (200) mm

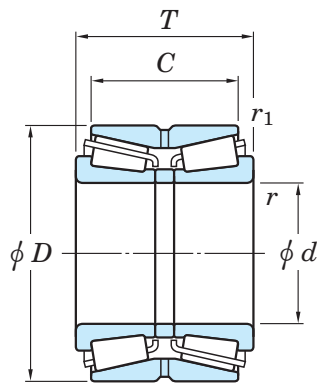

d	Boundary dimensions (mm)					Basic load ratings (kN)		Limiting speeds (min^{-1})	
	D	T	C	r min.	r_1 min.	C_R	C_{0r}	Grease lub.	Oil lub.
150	270	164	130	3	1	1 210	2 130	1 100	1 400
	320	154	120	4	1.5	1 430	2 160	930	1 200
160	240	60	53	3	1	324	565	1 100	1 500
	240	75	60	3	1	406	756	1 100	1 500
	270	86	76	3	1	592	950	1 000	1 400
	270	108	86	3	1	727	1 270	1 000	1 400
	290	115	91	3	1	929	1 500	980	1 300
	290	178	144	3	1	1 360	2 420	1 000	1 300
170	260	67	60	3	1	382	642	1 000	1 400
	260	84	67	3	1	502	969	1 000	1 400
	280	88	78	3	1	599	1 050	970	1 300
	280	110	88	3	1	776	1 390	980	1 300
	310	125	97	4	1.5	1 060	1 730	900	1 200
	310	192	152	4	1.5	1 540	2 760	910	1 200
180	280	74	66	3	1	464	801	950	1 300
	280	93	74	3	1	584	1 080	960	1 300
	300	96	85	4	1.5	693	1 240	910	1 200
	300	120	96	4	1.5	894	1 630	900	1 200
	320	127	99	4	1.5	1 060	1 740	860	1 200
	320	192	152	4	1.5	1 640	3 030	880	1 200
190	290	75	67	3	1	487	866	910	1 200
	290	94	75	3	1	632	1 170	900	1 200
	320	104	92	4	1.5	808	1 450	830	1 100
	320	130	104	4	1.5	1 020	1 860	840	1 100
	340	133	105	4	1.5	1 250	2 060	800	1 100
	340	204	160	4	1.5	1 870	3 480	810	1 100
200	310	82	73	3	1	572	1 040	850	1 100

[Remark] Bearings not shown above (e.g. inch series) are shown in catalog "large size ball & roller bearings".

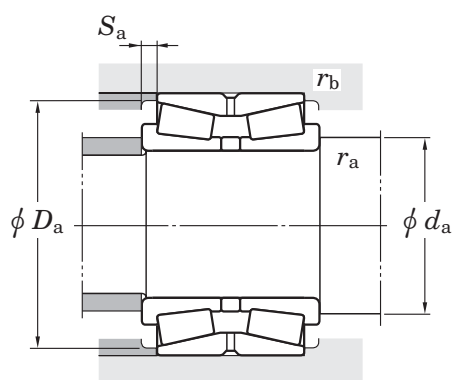

Bearing No.	Mounting dimensions (mm)					Constant <i>e</i>	Axial load factors			(Refer.) Mass (kg)
	<i>d_a</i> min.	<i>D_a</i> min.	<i>S_a</i> min.	<i>r_a</i> max.	<i>r_b</i> max.		<i>Y₂</i>	<i>Y₃</i>	<i>Y₀</i>	
46T32230JR/130	168	254	17	3	1	0.44	1.55	2.31	1.52	38
46T30330JR/120	172	292	17	4	1.5	0.35	1.96	2.91	1.91	56
46232	174	228	3.5	2.5	1	0.33	2.03	3.02	1.98	8.71
46232A	174	226	7.5	2.5	1	0.33	2.03	3.02	1.98	10.6
46332	174	252	5	2.5	1	0.35	1.95	2.90	1.91	18.8
46332A	174	252	11	2.5	1	0.35	1.95	2.90	1.91	23.1
46T30232JR/91	178	269	12	3	1	0.44	1.55	2.31	1.52	29.9
46T32232JR/144	178	274	17	3	1	0.44	1.55	2.31	1.52	47.6
46234	184	243	3.5	2.5	1	0.33	2.03	3.02	1.98	11.4
46234A	184	244	8.5	2.5	1	0.33	2.03	3.02	1.98	14.7
46334	184	263	5	2.5	1	0.33	2.06	3.06	2.01	19.8
46334A	184	260	11	2.5	1	0.33	2.06	3.06	2.01	24.7
46T30234JR/97	192	288	14	4	1.5	0.44	1.55	2.31	1.52	37.5
46T32234JR/152	192	294	20	4	1.5	0.44	1.55	2.31	1.52	58.8
46236	194	263	4	2.5	1	0.33	2.03	3.02	1.98	15.5
46236A	194	261	9.5	2.5	1	0.33	2.03	3.02	1.98	19.0
46336	198	277	5.5	3	1.5	0.33	2.06	3.06	2.01	25.8
46336A	198	279	12	3	1.5	0.33	2.06	3.06	2.01	31.3
46T30236JR/99	202	297	14	4	1.5	0.45	1.5	2.23	1.47	40.1
46T32236JR/152	202	303	20	4	1.5	0.45	1.5	2.23	1.47	62.5
46238	204	272	4	2.5	1	0.32	2.12	3.15	2.07	16.5
46238A	204	274	9.5	2.5	1	0.33	2.03	3.02	1.98	20.0
46338	208	298	6	3	1.5	0.35	1.95	2.90	1.91	31.9
46338A	208	298	13	3	1.5	0.35	1.95	2.90	1.91	39.0
46T30238JR/105	212	318	14	4	1.5	0.44	1.55	2.31	1.52	47.8
46T32238JR/160	212	323	22	4	1.5	0.44	1.55	2.31	1.52	75.1
46240	214	288	4.5	2.5	1	0.32	2.12	3.15	2.07	21.4

Double-row tapered roller bearings

TDO type

d (200) ~ (300) mm

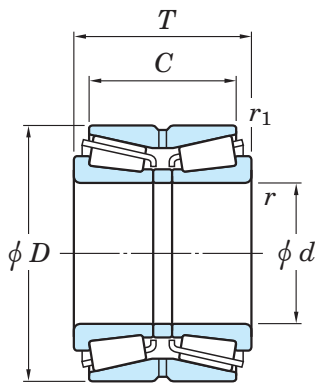

d	Boundary dimensions (mm)					Basic load ratings (kN)		Limiting speeds (min^{-1})	
	D	T	C	r min.	r_1 min.	C_R	C_{0r}	Grease lub.	Oil lub.
200	310	103	82	3	1	713	1 380	840	1 100
	340	112	100	4	1.5	939	1 580	780	1 000
	340	140	112	4	1.5	1 110	2 040	770	1 000
	360	142	110	4	1.5	1 360	2 240	750	1 000
	360	218	174	4	1.5	2 130	3 760	770	1 000
220	340	90	80	4	1.5	677	1 240	750	990
	340	113	90	4	1.5	832	1 620	750	1 000
	370	120	107	5	1.5	1 070	1 810	700	930
	370	150	120	5	1.5	1 330	2 470	710	940
	400	150	114	4	1.5	1 730	2 880	660	890
240	360	92	82	4	1.5	768	1 430	690	920
	360	115	92	4	1.5	990	1 980	690	920
	400	128	114	5	1.5	1 190	2 180	630	840
	400	160	128	5	1.5	1 540	3 060	630	850
260	400	104	92	5	1.5	935	1 830	610	820
	400	130	104	5	1.5	1 210	2 480	610	810
	440	144	128	5	1.5	1 510	2 880	560	750
	440	180	144	5	1.5	2 010	3 960	570	760
280	420	106	94	5	1.5	1 010	1 970	570	760
	420	133	106	5	1.5	1 250	2 610	570	760
	460	146	130	6	2	1 550	2 930	530	700
	460	183	146	6	2	2 040	3 940	520	690
300	460	118	105	5	1.5	1 290	2 400	500	670
	460	148	118	5	1.5	1 630	3 230	510	680
	500	160	142	6	2	1 980	3 540	470	620
	500	200	160	6	2	2 270	4 630	470	630

[Remark] Bearings not shown above (e.g. inch series) are shown in catalog "large size ball & roller bearings".

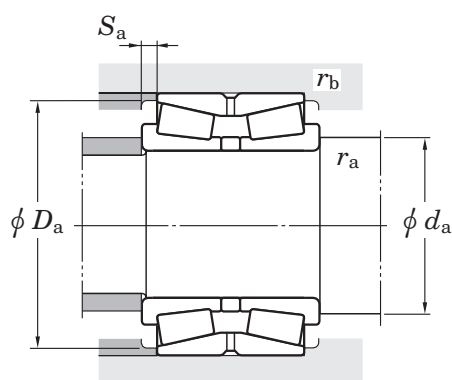

Bearing No.	Mounting dimensions (mm)					Constant <i>e</i>	Axial load factors			(Refer.) Mass (kg)
	<i>d_a</i> min.	<i>D_a</i> min.	<i>S_a</i> min.	<i>r_a</i> max.	<i>r_b</i> max.		<i>Y₂</i>	<i>Y₃</i>	<i>Y₀</i>	
46240A	214	289	10.5	2.5	1	0.32	2.12	3.15	2.07	26.3
46340	218	316	6	3	1.5	0.35	1.95	2.90	1.91	39.6
46340A	218	319	14	3	1.5	0.35	1.95	2.90	1.91	48.2
46T30240JR/110	222	336	16	4	1.5	0.44	1.55	2.31	1.52	56.5
46T32240JR/174	222	340	22	4	1.5	0.41	1.66	2.47	1.62	88.2
46244	238	319	5	3	1.5	0.32	2.12	3.15	2.07	27.8
46244A	238	318	11.5	3	1.5	0.32	2.12	3.15	2.07	34.2
46344	242	346	6.5	4	1.5	0.35	1.95	2.90	1.91	49.1
46344A	242	343	15	4	1.5	0.35	1.95	2.90	1.91	60.1
46T30244JR/114	242	371	18	4	1.5	0.42	1.61	2.39	1.57	75.8
46248	258	338	5	3	1.5	0.32	2.12	3.15	2.07	29.6
46248A	258	341	11.5	3	1.5	0.32	2.12	3.15	2.07	36.9
46348	262	377	7	4	1.5	0.35	1.95	2.90	1.91	59.0
46348A	262	373	16	4	1.5	0.35	1.95	2.90	1.91	76.2
46252	282	373	6	4	1.5	0.33	2.03	3.02	1.98	44.6
46252A	282	376	13	4	1.5	0.32	2.12	3.15	2.07	54.8
46352	282	410	8	4	1.5	0.35	1.95	2.90	1.91	83.8
46352A	282	409	18	4	1.5	0.35	1.95	2.90	1.91	105
46256	302	395	6	4	1.5	0.33	2.03	3.02	1.98	46.9
46256A	302	394	13.5	4	1.5	0.33	2.03	3.02	1.98	58.9
46356	308	430	8	5	2	0.35	1.95	2.90	1.91	90.0
46356A	308	434	18.5	5	2	0.35	1.95	2.90	1.91	111
46260	322	436	6.5	4	1.5	0.32	2.12	3.15	2.07	64.6
46260A	322	433	15	4	1.5	0.32	2.12	3.15	2.07	80.2
46360	328	469	9	5	2	0.35	1.95	2.90	1.91	116
46360A	328	466	20	5	2	0.35	1.95	2.90	1.91	144

Double-row tapered roller bearings

TDO type

d (300) ~420 mm

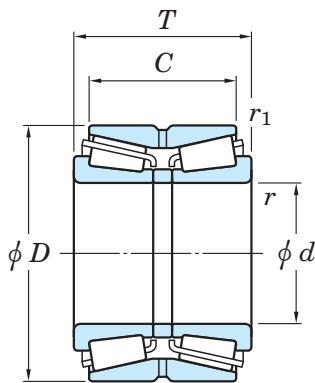

d	Boundary dimensions (mm)					Basic load ratings (kN)		Limiting speeds (min ⁻¹)	
	D	T	C	r min.	r_1 min.	C_R	C_{0r}	Grease lub.	Oil lub.
300	500	200	160	6	1.5	2 500	4 650	—	—
320	480	121	108	5	1.5	1 430	2 700	480	640
	480	151	121	5	1.5	1 650	3 410	470	630
	540	176	157	6	2	2 440	4 570	420	560
	540	220	176	6	2	2 610	5 390	430	570
340	520	133	118	6	2	1 550	3 070	420	570
	520	165	133	6	2	1 930	4 060	420	560
	580	190	169	6	2	2 540	4 620	380	510
	580	238	190	6	2	3 160	6 340	370	500
360	540	134	120	6	2	1 660	3 290	400	530
	540	169	134	6	2	2 020	4 230	390	530
	600	192	171	6	2	2 680	4 880	360	480
	600	240	192	6	2	3 660	7 230	360	480
380	560	135	122	6	2	1 740	3 560	370	500
	560	171	135	6	2	2 240	4 670	380	500
	620	194	173	6	2	2 870	5 220	340	450
	620	243	194	6	2	3 490	7 360	330	440
400	600	148	132	6	2	1 870	3 720	340	460
	600	185	148	6	2	2 420	5 150	340	460
	650	200	178	6	3	2 980	5 920	320	420
	650	250	200	6	3	4 060	8 850	310	420
420	620	150	134	6	2	2 010	4 130	320	420
	620	188	150	6	2	2 700	5 660	320	430
	700	224	200	6	3	3 700	6 880	290	380
	700	280	224	6	3	4 810	9 620	290	380

[Remark] Bearings not shown above (e.g. inch series) are shown in catalog "large size ball & roller bearings".

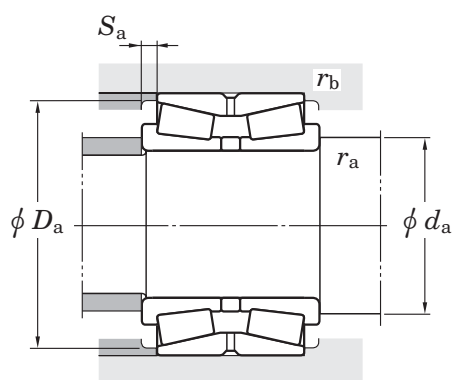

Bearing No.	Mounting dimensions (mm)					Constant <i>e</i>	Axial load factors			(Refer.) Mass (kg)
	<i>d_a</i> min.	<i>D_a</i> min.	<i>S_a</i> min.	<i>r_a</i> max.	<i>r_b</i> max.		<i>Y₂</i>	<i>Y₃</i>	<i>Y₀</i>	
46360D	328	475	20	5	1.5	0.40	1.68	2.50	1.64	139
46264	342	452	6.5	4	1.5	0.32	2.12	3.15	2.07	71.6
46264A	342	454	15	4	1.5	0.32	2.12	3.15	2.07	87.7
46364	348	502	9.5	5	2	0.35	1.95	2.90	1.91	154
46364A	348	497	22	5	2	0.35	1.95	2.90	1.91	190
46268	368	489	7.5	5	2	0.32	2.12	3.15	2.07	95.3
46268A	368	491	16	5	2	0.32	2.12	3.15	2.07	117
46368	368	539	10.5	5	2	0.35	1.95	2.90	1.91	198
46368A	368	543	24	5	2	0.35	1.95	2.90	1.91	244
46272	388	510	7	5	2	0.32	2.12	3.15	2.07	93.0
46272A	388	512	17.5	5	2	0.32	2.12	3.15	2.07	124
46372	388	557	10.5	5	2	0.35	1.95	2.90	1.91	206
46372A	388	568	24	5	2	0.39	1.74	2.59	1.70	254
46276	408	530	6.5	5	2	0.32	2.12	3.15	2.07	100
46276A	408	531	18	5	2	0.39	1.74	2.59	1.70	129
46376	408	582	10.5	5	2	0.39	1.74	2.59	1.70	215
46376A	408	587	24.5	5	2	0.35	1.95	2.90	1.91	265
46280	428	560	8	5	2	0.32	2.12	3.15	2.07	135
46280A	428	563	18.5	5	2	0.32	2.12	3.15	2.07	167
46380	428	605	11	5	2.5	0.35	1.95	2.90	1.91	243
46380A	428	610	25	5	2.5	0.35	1.95	2.90	1.91	306
46284	448	590	8	5	2	0.33	2.03	3.02	1.98	142
46284A	448	589	19	5	2	0.39	1.74	2.59	1.70	176
46384	448	656	12	5	2.5	0.39	1.74	2.59	1.70	325
46384A	448	659	28	5	2.5	0.39	1.74	2.59	1.70	400

Double-row tapered roller bearings

TDO type

d 440 ~ 500 mm

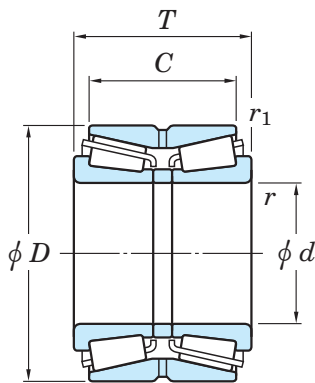

d	Boundary dimensions (mm)					Basic load ratings (kN)		Limiting speeds (min^{-1})	
	D	T	C	r min.	r_1 min.	C_R	C_{0r}	Grease lub.	Oil lub.
440	650	157	140	6	3	2 260	4 430	300	390
	650	196	157	6	3	3 000	6 370	300	400
	720	226	201	6	3	3 940	8 110	270	360
	720	283	226	6	3	4 940	10 100	270	360
460	680	163	145	6	3	2 500	5 340	280	370
	680	204	163	6	3	3 220	6 850	280	370
	760	240	214	7.5	4	4 580	9 000	250	330
	760	300	240	7.5	4	5 680	11 600	250	330
480	700	165	147	6	3	2 530	5 300	260	340
	700	206	165	6	3	3 220	7 230	260	340
	790	248	221	7.5	4	4 640	8 920	230	310
	790	310	248	7.5	4	5 990	12 400	230	310
500	720	167	149	6	3	2 580	5 690	250	330
	720	209	167	6	3	3 500	7 850	250	330
	830	264	235	7.5	4	5 220	10 900	210	280
	830	330	264	7.5	4	6 780	14 000	210	280

[Remark] Bearings not shown above (e.g. inch series) are shown in catalog "large size ball & roller bearings".

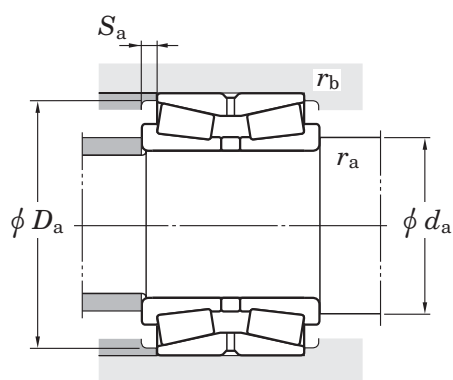

Bearing No.	Mounting dimensions (mm)					Con- stant <i>e</i>	Axial load factors			(Refer.) Mass (kg)
	<i>d_a</i> min.	<i>D_a</i> min.	<i>S_a</i> min.	<i>r_a</i> max.	<i>r_b</i> max.		<i>Y₂</i>	<i>Y₃</i>	<i>Y₀</i>	
46288	468	622	8.5	5	2.5	0.33	2.03	3.02	1.98	156
46288A	468	620	19.5	5	2.5	0.39	1.74	2.59	1.70	198
46388	468	676	12.5	5	2.5	0.39	1.74	2.59	1.70	354
46388A	468	679	28.5	5	2.5	0.40	1.68	2.51	1.65	418
46292	488	637	9	5	2.5	0.37	1.83	2.72	1.78	196
46292A	488	646	20.5	5	2.5	0.39	1.74	2.59	1.70	232
46392	496	710	13	6	3	0.39	1.74	2.59	1.70	424
46392A	496	718	30	6	3	0.39	1.74	2.59	1.70	506
46296	508	672	9	5	2.5	0.33	2.03	3.02	1.98	186
46296A	508	666	20.5	5	2.5	0.33	2.03	3.02	1.98	240
46396	516	742	13.5	6	3	0.39	1.74	2.59	1.70	457
46396A	516	749	31	6	3	0.39	1.74	2.59	1.70	560
462/500	528	679	9	5	2.5	0.40	1.71	2.54	1.67	210
462/500A	528	690	21	5	2.5	0.42	1.62	2.41	1.58	258
463/500	536	776	14.5	6	3	0.39	1.74	2.59	1.70	559
463/500A	536	784	33	6	3	0.39	1.74	2.59	1.70	669

Double-row tapered roller bearings

TDI type

d 100 ~ (220) mm

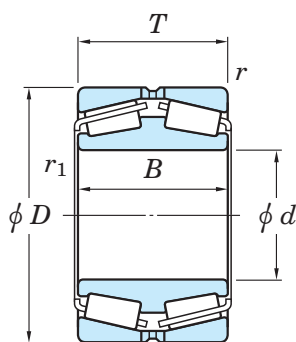

d	Boundary dimensions (mm)					Basic load ratings (kN)		Limiting speeds (min ⁻¹)	
	D	B	T	$r_{\min.}$	$r_{1\min.}$	C_r	C_{0r}	Grease lub.	Oil lub.
100	165	52	52	2	2.5	237	384	1 800	2 300
110	180	56	56	2	2.5	300	505	1 600	2 100
120	180	46	46	2	2.5	229	424	1 500	2 100
	200	62	62	2	2.5	353	598	1 400	1 900
130	200	52	52	2	2.5	300	548	1 400	1 800
	210	64	64	2	2.5	412	657	1 300	1 800
140	210	53	53	2	2.5	311	564	1 300	1 800
	225	68	68	2.5	3	486	807	1 200	1 700
150	225	56	56	2.5	3	355	686	1 200	1 600
	250	80	80	2.5	3	593	955	1 100	1 500
160	240	60	60	2.5	3	421	705	1 100	1 500
	270	86	86	2.5	3	678	1 100	1 000	1 400
170	260	67	67	2.5	3	521	956	1 000	1 400
	280	88	88	2.5	3	723	1 210	970	1 300
180	280	74	74	2.5	3	575	1 050	950	1 300
	300	96	96	3	4	860	1 370	910	1 200
190	290	75	75	2.5	3	599	1 130	900	1 200
	320	104	104	3	4	981	1 590	840	1 100
200	310	82	82	2.5	3	728	1 410	830	1 100
	340	112	112	3	4	1 080	1 840	770	1 000
220	340	90	90	3	4	805	1 460	740	990

[Remark] Bearings not shown above (e.g. inch series) are shown in catalog "large size ball & roller bearings".

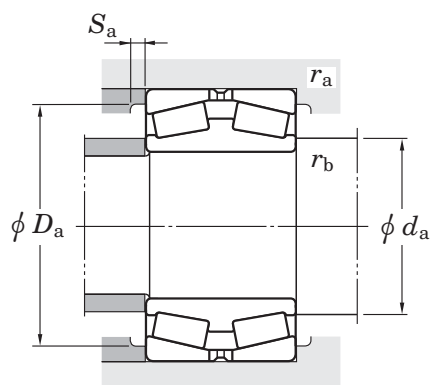

Bearing No.	Mounting dimensions (mm)							Constant <i>e</i>	Axial load factors			(Refer.) Mass (kg)
	<i>d_a</i> max.	<i>D_a</i> max.	<i>D_a</i> min.	<i>S_a</i> min.	<i>r_a</i> max.	<i>r_b</i> max.	<i>Y₂</i>		<i>Y₃</i>	<i>Y₀</i>		
45320	119	155	148	3.9	2	2	0.35	1.95	2.90	1.91	4.26	
45322	128	170	160	4	2	2	0.35	1.95	2.90	1.91	5.40	
45224 45324	138 142	170 190	163 178	4	2	2	0.26 0.35	2.55 1.95	3.80 2.90	2.50 1.91	4.08 7.92	
45226 45326	152 153	190 200	179 185	4	2	2	0.27 0.36	2.47 1.87	3.67 2.79	2.41 1.83	5.96 8.41	
45228 45328	159 160	200 213	188 210	4	2	2	0.27 0.40	2.47 1.68	3.67 2.50	2.41 1.64	6.45 10.0	
45230 45330	174 179	213 238	203 220	4	2	2.5	0.26 0.35	2.55 1.95	3.80 2.90	2.50 1.91	7.87 15.5	
45232 45332	184 193	228 258	217 237	5	2	2.5	0.24 0.35	2.79 1.95	4.15 2.90	2.73 1.91	9.22 19.8	
45234 45334	195 201	248 268	233 247	5	2	2.5	0.31 0.33	2.21 2.03	3.29 3.02	2.16 1.98	12.4 21.6	
45236 45336	208 210	268 286	250 263	5	2	2.5	0.28 0.35	2.43 1.95	3.61 2.90	2.37 1.91	16.8 26.5	
45238 45338	219 224	278 306	260 280	5	2	2.5	0.26 0.35	2.55 1.95	3.80 2.90	2.50 1.91	17.7 34.0	
45240 45340	234 244	298 326	280 300	5	2	2.5	0.26 0.35	2.55 1.95	3.80 2.90	2.50 1.91	22.9 41.9	
45244	259	326	306	5	2.5	3	0.28	2.43	3.61	2.37	28.5	

Double-row tapered roller bearings

TDI type

d (220) ~ (420) mm

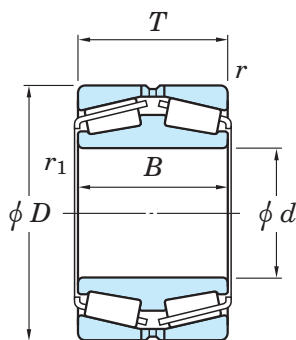

d	Boundary dimensions (mm)					Basic load ratings (kN)		Limiting speeds (min ⁻¹)	
	D	B	T	$r_{\min.}$	$r_{1\min.}$	C_r	C_{0r}	Grease lub.	Oil lub.
220	370	120	120	4	5	1 210	2 060	700	930
230	350	90	90	3	4	791	1 560	710	950
240	360 400	92 128	92 128	3 4	4 5	915 1 430	1 790 2 470	690 630	920 840
260	400 440	104 144	104 144	4 4	5 5	1 140 1 890	2 120 3 440	610 560	810 750
280	420 460	106 146	106 146	4 5	5 6	1 190 1 930	2 470 3 320	560 520	750 700
300	460 500	118 160	118 160	4 5	5 6	1 610 2 120	3 150 4 240	500 470	670 630
320	480 540	121 176	121 176	4 5	5 6	1 630 2 690	3 180 5 280	470 430	630 570
340	520 580	133 190	133 190	5 5	6 6	1 880 3 290	3 850 5 470	420 390	570 510
360	540 600	134 192	134 192	5 5	6 6	2 050 3 360	3 910 6 750	400 360	540 490
380	560 620	135 194	135 194	5 5	6 6	2 060 3 070	3 790 6 360	380 340	500 450
400	600 650	148 200	148 200	5 6	6 6	2 410 3 850	4 960 7 810	340 320	450 420
420	620	150	150	5	6	2 600	5 200	320	430

[Remark] Bearings not shown above (e.g. inch series) are shown in catalog "large size ball & roller bearings".

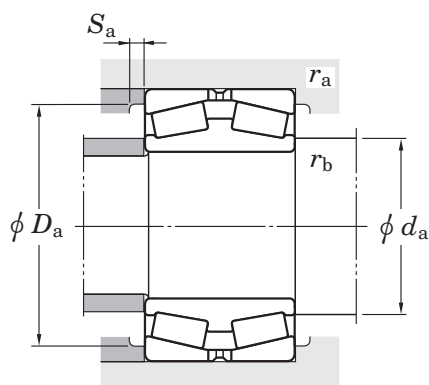

Bearing No.	Mounting dimensions (mm)							Constant <i>e</i>	Axial load factors			(Refer.) Mass (kg)
	<i>d_a</i> max.	<i>D_a</i> max.	<i>D_a</i> min.	<i>S_a</i> min.	<i>r_a</i> max.	<i>r_b</i> max.	<i>Y₂</i>		<i>Y₃</i>	<i>Y₀</i>		
45344	263	352	324	5	3	4	0.35	1.95	2.90	1.91	50.8	
45246	267	336	318	6	2.5	3	0.28	2.43	3.61	2.37	30.6	
45248	271	346	325	5	2.5	3	0.32	2.12	3.15	2.07	32.2	
45348	286	382	354	5	3	4	0.35	1.95	2.90	1.91	65.4	
45252	302	382	360	6	3	4	0.25	2.74	4.08	2.68	48.1	
45352	313	422	386	6	3	4	0.35	1.95	2.90	1.91	92.2	
45256	321	402	370	6	3	4	0.25	2.69	4.00	2.63	51.9	
45356	323	438	409	6	4	5	0.39	1.74	2.59	1.70	93.1	
45260	350	442	418	6	3	4	0.25	2.74	4.08	2.68	78.5	
45360	356	478	440	6	4	5	0.35	1.95	2.90	1.91	129	
45264	368	462	434	6	3	4	0.26	2.55	3.80	2.50	77.8	
45364R	378	518	474	6	4	5	0.32	2.12	3.15	2.07	167	
45268	398	498	464	6	4	5	0.26	2.55	3.80	2.50	104	
45368	401	558	515	6	4	5	0.32	2.12	3.15	2.07	202	
45272	408	518	488	11	4	5	0.32	2.12	3.15	2.07	101	
45372	419	578	528	10	4	5	0.32	2.12	3.15	2.07	228	
45276	428	538	510	6	4	5	0.27	2.47	3.67	2.41	112	
45376	445	598	545	6	4	5	0.32	2.12	3.15	2.07	234	
45280	452	578	545	6	4	5	0.33	2.03	3.02	1.98	143	
45380	458	622	580	11	5	5	0.39	1.74	2.59	1.70	265	
45284	475	598	564	6	4	5	0.33	2.03	3.02	1.98	152	

Double-row tapered roller bearings

TDI type

d (420) ~ 500 mm

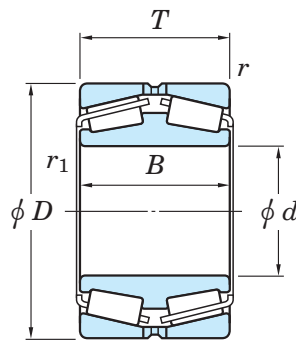

d	Boundary dimensions (mm)					Basic load ratings (kN)		Limiting speeds (min ⁻¹)	
	D	B	T	r min.	r_1 min.	C_r	C_{0r}	Grease lub.	Oil lub.
420	700	224	224	6	6	4 710	8 380	280	380
440	650	157	157	6	6	2 750	5 500	300	390
	720	226	226	6	6	4 990	9 130	270	360
460	680	163	163	6	6	3 000	5 660	280	370
	760	240	240	7.5	7.5	5 230	10 400	250	330
480	700	165	165	6	6	3 060	6 710	260	350
	790	248	248	7.5	7.5	5 710	11 600	230	310
500	720	167	167	6	6	3 430	7 350	250	330
	830	264	264	7.5	7.5	6 280	12 300	210	280

[Remark] Bearings not shown above (e.g. inch series) are shown in catalog "large size ball & roller bearings".

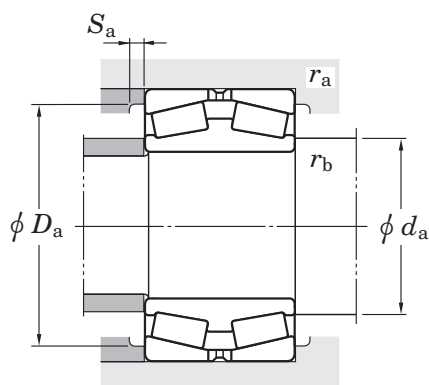

Bearing No.	Mounting dimensions (mm)							Con- stant <i>e</i>	Axial load factors			(Refer.) Mass (kg)
	<i>d_a</i> max.	<i>D_a</i> max.	<i>D_a</i> min.	<i>S_a</i> min.	<i>r_a</i> max.	<i>r_b</i> max.	<i>Y₂</i>		<i>Y₃</i>	<i>Y₀</i>		
45384	488	672	623	7	5	5	0.39	1.74	2.59	1.70	352	
45288	500	622	592	10	5	5	0.28	2.43	3.61	2.37	182	
45388	506	692	642	7	5	5	0.39	1.74	2.59	1.70	367	
45292	510	652	616	6	5	5	0.39	1.74	2.59	1.70	197	
45392	532	724	677	7	6	6	0.39	1.74	2.59	1.70	444	
45296	531	672	625	6	5	5	0.40	1.68	2.50	1.64	215	
45396	555	754	703	7	6	6	0.39	1.74	2.59	1.70	494	
452/500	545	692	645	8	5	5	0.39	1.74	2.59	1.70	222	
453/500	587	794	729	7	6	6	0.33	2.03	3.02	1.98	586	

KOYO

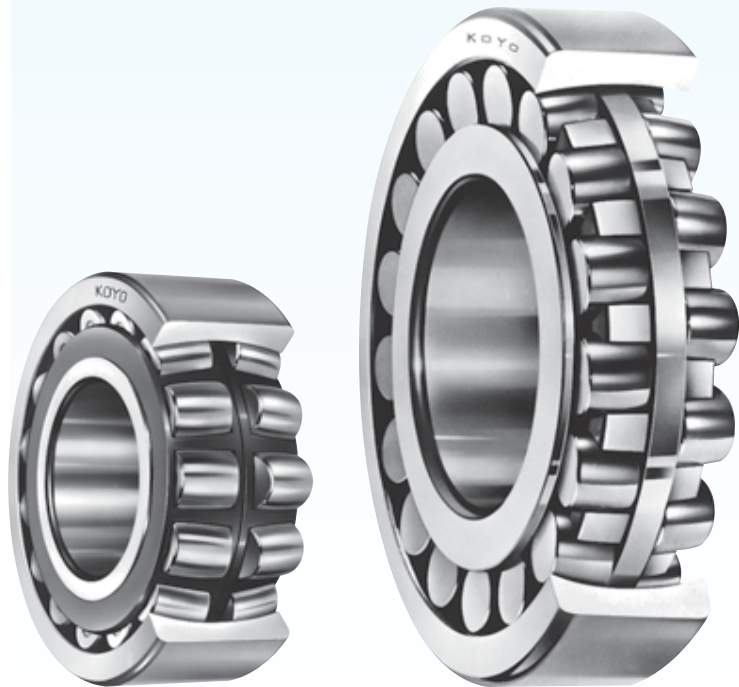

Spherical roller bearings

Spherical roller bearings feature a large load rating capacity and self-aligning capability.

This type of bearing is suitable for low- or medium-speed applications which involve heavy or impact loading.

- These bearings are divided into R(RR), RH(RHR) and RHA types, which differ in internal structure. (refer to Table 1.)
- Each type can be produced with a cylindrical bore or tapered bore.

Bearings with a tapered bore can be fit and removed easily using an adapter assembly or withdrawal sleeve.

The rate of taper is equivalent among all bearing series.

240 and 241 series ... 1 : 30 (supplementary code "K30")

Others ... 1 : 12 (supplementary code "K")

Spherical roller bearings

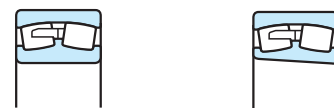

Cylindrical bore Tapered bore

Bore diameter **25 – 500 mm**

Adapter assemblies

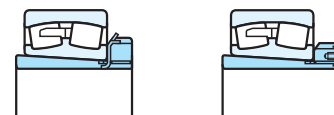



Bore diameter **20 – 470 mm**

Withdrawal sleeves



Bore diameter **35 – 480 mm**

Table 1 Spherical roller bearings : types and structures

Structure	 R, RR type	 RH, RHR type	 RHA type
Roller	Convex asymmetrical roller	Convex symmetrical roller	Convex symmetrical roller
Cage	Copper alloy prong type machined cage	Pressed steel cage	Copper alloy integral type machined cage
Inner ring (with or without rib)	With center rib	Without center rib (guide ring)	Without center rib (guide ring)
	With ribs on both sides (to prevent rollers from falling)	Without ribs on both sides	With ribs on both sides (to prevent rollers from falling)
Characteristics	Superior to RH, RHR and RHA types in high-speed performance. (There are some exceptional cases due to different interior specifications.)		

■ Spherical roller bearings for shaker screens

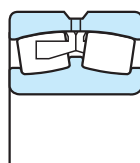
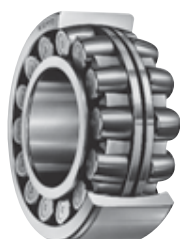

- These bearings consist of convex asymmetric rollers and a prong type, copper alloy, outer ring guided, machined cage. This cage possesses optimum characteristics for use with shaker screens.
- The bearings most commonly used with shaker screens are 223 series spherical roller bearings. They are identified by the supplementary code "ROVS W502." The outer ring outside diameter tolerance of these bearings is held to a small allowable variation.

■ Bearings with lubrication holes and a lubrication groove

- Outer rings can be provided with lubrication holes, a lubrication groove and an anti-rotation pin hole. (Specifications are given in Table 4.)

- Inner rings can also be provided with lubrication holes and a lubrication groove.

Table 2 Supplementary codes for identification of bearings with lubrication holes, lubrication groove and anti-rotation pin hole (outer ring)

Supplementary code		Number of lubrication holes	Hole layout
With lubrication holes and lubrication groove	With lubrication holes, lubrication groove and anti-rotation pin hole		
W33	W3N	3 ¹⁾	3 equally spaced positions ¹⁾
W33A	W3NA	4	4 equally spaced positions
–	W3NB	5	6 equally spaced positions ²⁾
W33C	W3NC	6	6 equally spaced positions
–	W3ND	7	8 equally spaced positions ²⁾
W33T	–	8	8 equally spaced positions

Table 3 Supplementary codes for identification of bearings with lubrication holes and/or lubrication groove

Supplementary code	Inner ring		Outer ring	
	Number of lubrication holes	Lubrication groove	Number of lubrication holes	Lubrication groove
W513	3	–	3	○
W518	3	–	3	–
W26	3	–	–	–

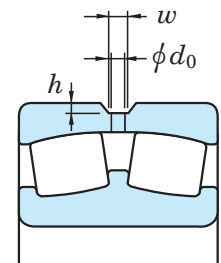

[Notes] 1) Also 4 or 6 holes are provided in smaller size bearings, consult with JTEKT.

2) One hole is used for the antirotation pin.

[Remark] Boldfaced codes indicate JTEKT standards.

Table 4 (1) Lubrication hole and lubrication groove dimensions Unit : mm

Bore diameter number	Nominal bore diameter d	239			230			240			231			241			222			232			213			223			
		d_0	w	h	d_0	w	h	d_0	w	h	d_0	w	h	d_0	w	h	d_0	w	h	d_0	w	h	d_0	w	h	d_0	w	h	
5	25	–	–	–	–	–	–	–	–	–	–	–	–	–	–	–	3	4	0.7	–	–	–	–	–	–	–	–	–	–
6	30	–	–	–	–	–	–	–	–	–	–	–	–	–	–	–	3	4	0.7	–	–	–	3	4	0.7	–	–	–	–
7	35	–	–	–	–	–	–	–	–	–	–	–	–	–	–	–	3	4	0.8	–	–	–	3	4	0.7	3	4	1	–
8	40	–	–	–	–	–	–	–	–	–	–	–	–	–	–	–	3	4	0.8	–	–	–	3	4	0.7	4	5	1	–
9	45	–	–	–	–	–	–	–	–	–	–	–	–	–	–	–	3	4	0.8	–	–	–	3	4	0.7	4	6	1	–
10	50	–	–	–	–	–	–	–	–	–	–	–	–	–	–	–	3	4	0.8	–	–	–	3	4	0.7	4	6	1	–
11	55	–	–	–	–	–	–	–	–	–	–	–	–	–	–	–	3	4	0.8	–	–	–	3	4	0.7	4	6	1.1	–
12	60	–	–	–	–	–	–	–	–	–	–	–	–	–	–	–	3	4	1	–	–	–	3	4	1	4	6	1.1	–
13	65	–	–	–	–	–	–	–	–	–	–	–	–	–	–	–	3	4	1	–	–	–	3	4	1	4	6	1.2	–
14	70	–	–	–	–	–	–	–	–	–	–	–	–	–	–	–	3	4	1	–	–	–	3	4	1	5	7	1.3	–
15	75	–	–	–	–	–	–	–	–	–	–	–	–	–	–	–	3	4	1	–	–	–	3	4	1	5	7	1.3	–
16	80	–	–	–	–	–	–	–	–	–	–	–	–	–	–	–	3	4	1	4	6	1.2	4	6	1	5	7	1.3	–
17	85	–	–	–	–	–	–	–	–	–	–	–	–	–	–	–	4	5	1	4	6	1.2	4	6	1.2	6	8	1.3	–
18	90	–	–	–	–	–	–	–	–	–	–	–	–	–	–	–	4	5	1	5	8	1.2	4	6	1.2	6	8	1.3	–
19	95	–	–	–	–	–	–	–	–	–	–	–	–	–	–	–	5	6	1.2	5	8	1.2	4	6	1.2	6	8	2	–
20	100	–	–	–	4	5	1	–	–	–	5	6	1.4	–	–	–	5	6	1.2	5	8	1.2	4	6	1.2	6	8	2	–
22	110	–	–	–	5	7	1	–	–	–	5	6	1.4	6	8	1.5	5	7	1.5	6	8	1.7	4	6	1.2	6	8	2	–
24	120	–	–	–	5	7	1	5	6	1.4	5	6	1.4	6	8	1.5	5	7	1.5	6	10	1.7	–	–	–	8	10	2.5	–
26	130	–	–	–	5	7	1.2	6	8	1.5	5	6	1.5	6	8	1.5	5	7	1.5	6	10	1.7	–	–	–	8	12	2.5	–
28	140	4	5	1	5	7	1.2	6	8	1.5	6	8	1.5	8	10	2	6	8	1.8	8	10	2.5	–	–	–	12	14	3	–
30	150	5	7	1	5	8	1.2	6	8	1.5	6	10	1.5	8	10	2	6	10	1.8	8	10	2.5	–	–	–	12	14	3	–
32	160	5	7	1.2	5	8	1.2	6	8	1.5	8	12	2	10	12	2	10	12	2.5	10	12	2.5	–	–	–	12	14	3	–
34	170	5	7	1.2	6	10	1.5	8	10	2	8	12	2	10	12	2	12	14	3	10	12	2.5	–	–	–	12	14	3	–
36	180	6	7	1.3	8	12	1.5	10	12	2.5	10	12	2.5	10	12	2	12	14	3	10	12	2.5	–	–	–	14	16.5	4	–
38	190	5	7	1.2	10	12	2.5	10	12	2.5	10	12	2.5	10	12	2	12	14	3	12	14	3	–	–	–	14	16.5	4	–
40	200	6	8	1.5	10	12	2.5	10	12	2.5	12	14	3	12	14	3	12	14	3	12	14	3	–	–	–	14	16.5	4	–
44	220	6	8	1.5	10	12	2.5	10	12	2.5	12	14	3	12	14	3	12	14	3	12	14	3	–	–	–	14	16.5	4	–
48	240	6	8	1.5	10	12	2.5	10	12	2.5	12	14	3	12	14	3	14	16.5	4	14	16.5	4	–	–	–	14	16.5	4	–
52	260	10	12	2.5	12	14	3	12	14	3	12	14	3	12	14	3	14	16.5	4	14	16.5	4	–	–	–	14	16.5	4	–
56	280	10	12	2.5	12	14	3	12	14	3	12	14	3	12	14	3	14	16.5	4	14	16.5	4	–	–	–	14	16.5	4	–
60	300	10	12	2.5	12	14	3	12	14	3	12	14	3	12	14	3	14	16.5	4	14	16.5	4	–	–	–	14	16.5	4	–
64	320	10	12	2.5	12	14	3	12	14	3	14	16.5	4	14	16.5	4	14	16.5	4	14	16.5	4	–	–	–	14	16.5	4	–
68	340	12	14	3	14	16.5	4	14	16.5	3	14	16.5	4	14	16.5	4	14	16.5	4	14	16.5	4	–	–	–	14	16.5	4	–
72	360	12	14	3	14	16.5	4	14	16.5	3	14	16.5	4	14	16.5	4	14	16.5	4	14	16.5	4	–	–	–	14	16.5	4	–

Table 4 (2) Lubrication hole and lubrication groove dimensions Unit : mm

Bore diameter number	Nominal bore diameter d	239			230			240			231			241			222			232			213			223		
		d_0	w	h	d_0	w	h	d_0	w	h	d_0	w	h	d_0	w	h	d_0	w	h	d_0	w	h	d_0	w	h	d_0	w	h
76	380	12	14	3	14	16.5	4	14	16.5	3	14	16.5	4	14	16.5	4	—	—	—	14	16.5	4	—	—	—	—	—	—
80	400	12	14	3	14	16.5	4	14	16.5	4	14	16.5	4	14	16.5	4	—	—	—	14	16.5	4	—	—	—	—	—	—
84	420	12	14	3	14	16.5	4	14	16.5	4	14	16.5	4	14	16.5	4	—	—	—	14	16.5	4	—	—	—	—	—	—
88	440	14	16.5	4	14	16.5	4	14	16.5	4	14	16.5	4	14	16.5	4	—	—	—	14	16.5	4	—	—	—	—	—	—
92	460	14	16.5	4	14	16.5	4	14	16.5	4	14	16.5	4	14	16.5	4	—	—	—	14	16.5	4	—	—	—	—	—	—
96	480	14	16.5	4	14	16.5	4	14	16.5	4	14	16.5	4	14	16.5	4	—	—	—	14	16.5	4	—	—	—	—	—	—
/500	500	14	16.5	4	14	16.5	4	14	16.5	4	14	16.5	4	14	16.5	5	—	—	—	14	16.5	4	—	—	—	—	—	—

Boundary dimensions	As specified in JIS B 1512.
Tolerances	As specified in JIS B 1514-1, class 0. (refer to Table 7-3 on pp. A 54 – A 57.) Refer to Table 7-11 on p. A 70 for the tolerance of tapered bores.
Radial internal clearance	As specified in JIS B 1520. (refer to Table 10-9 on p. A 102.)
Recommended fits	Refer to Table 9-4 on pp. A 85, 86.
Standard cages	Refer to Table 5.
Allowable aligning angle	Refer to Table 5. (varies depending on bearing series.)
Equivalent radial load	Dynamic equivalent radial load $\left(\text{When } \frac{F_a}{F_r} \leq e \right) P_r = F_r + Y_1 F_a \quad \left(\text{When } \frac{F_a}{F_r} > e \right) P_r = 0.67 F_r + Y_2 F_a$ Static equivalent radial load $P_{0r} = F_r + Y_0 F_a$ [Note] Refer to the specification table for the values of axial load factors Y_1 , Y_2 and Y_0 and of constant e .

[Remark] If the ratio of axial load to radial load exceeds the value e given in the specification table ($F_a/F_r > e$), slippage occurs between rollers in rows that are not axial-loaded and the raceway. This may cause smearing, especially when the bearing is large. Consult with JTEKT on the use of bearings under such conditions.

Table 5 Application of standard cages and allowable aligning angle

Bearing series	Standard cages		Allowable aligning angle
	Pressed cage	Machined cage	
239 R	—	23930R – 239/500R	0.026 rad (1.5°)
230 R RH RHA	23022RH – 23036RH —	23038R – 230/500R — 23038RHA – 23096RHA	0.026 rad (1.5°)
240 R(RR) RH RHA	24024RH – 24034RH —	24036R – 240/500R — 24038RHA – 24096RHA	0.035 rad (2°)
231 R RH RHA	23122RH – 23134RH —	23136R – 231/500R — 23136RHA – 23196RHA	0.026 rad (1.5°)
241 R(RR) RH RHA	24122RH – 24130RH —	24132R – 241/500R — 24136RHA – 24196RHA	0.044 rad (2.5°)
222 R(RR) RH(RHR) RHA	22205RHR – 22230RH —	22232RR – 22272R — 22232RHA – 22260RHA	0.026 rad (1.5°)
232 R RH RHA	23218RH – 23230RH —	23232R – 232/500R — 23232RHA – 23296RHA	0.044 rad (2.5°)
213 R RH	21311RH – 21322RH —	21322R – 21328R —	0.017 rad (1°)
223 R(RR) RH(RHR) RHA	22308RHR – 22326RH —	22328R – 22360R — 22328RHA – 22356RHA	0.035 rad (2°)

Spherical roller bearings

d 25 ~ 70 mm

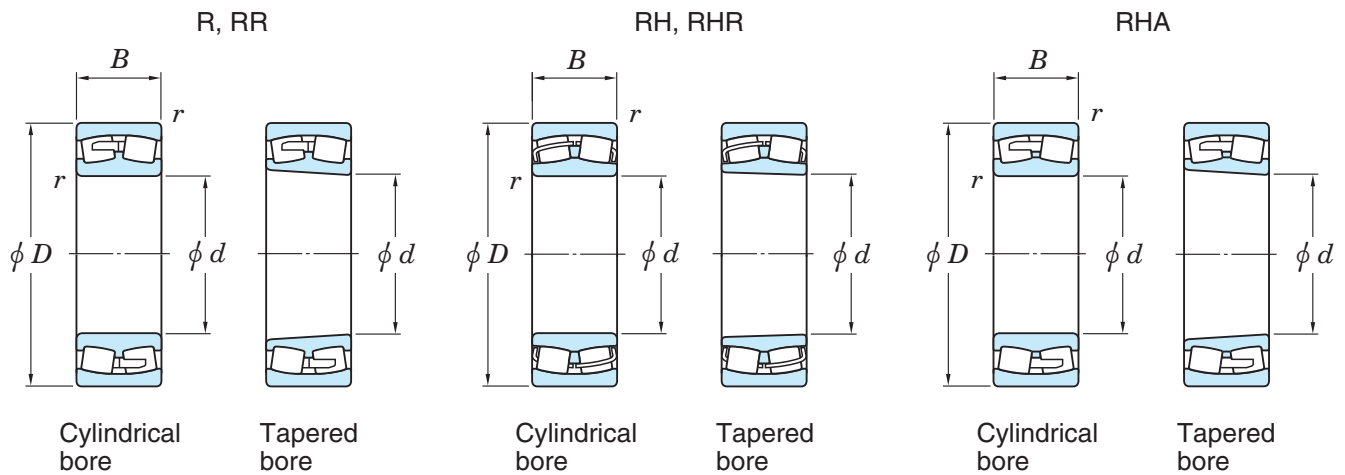

Boundary dimensions (mm)				Basic load ratings (kN)		Limiting speeds (min ⁻¹)		Bearing No.	
d	D	B	$r_{\text{min.}}$	C_r	C_{0r}	Grease lub.	Oil lub.	Cylindrical bore	Tapered bore
25	52	18	1	45.4	48.1	7 000	9 300	22205RHR	22205RHRK
30	62	20	1	61.2	65.9	5 900	7 900	22206RHR	22206RHRK
	72	19	1.1	59.3	62.7	5 200	7 000	21306RH	21306RHK
35	72	23	1.1	80.3	88.7	5 000	6 700	22207RHR	22207RHRK
	80	21	1.5	69.6	75.3	4 500	6 000	21307RH	21307RHK
40	80	23	1.1	90.9	102	4 500	6 000	22208RHR	22208RHRK
	90	23	1.5	85.7	95.5	4 100	5 500	21308RH	21308RHK
	90	33	1.5	136	152	4 100	5 500	22308RHR	22308RHRK
45	85	23	1.1	95.6	110	4 200	5 600	22209RHR	22209RHRK
	100	25	1.5	108	124	3 600	4 900	21309RH	21309RHK
	100	36	1.5	166	183	3 700	4 900	22309RHR	22309RHRK
50	90	23	1.1	103	122	3 900	5 200	22210RHR	22210RHRK
	110	27	2	128	151	3 300	4 400	21310RH	21310RHK
	110	40	2	204	237	3 300	4 500	22310RHR	22310RHRK
55	100	25	1.5	124	144	3 400	4 600	22211RHR	22211RHRK
	120	29	2	144	165	3 000	4 100	21311RH	21311RHK
	120	43	2	236	264	3 000	4 000	22311RHR	22311RHRK
60	110	28	1.5	153	181	3 100	4 200	22212RHR	22212RHRK
	130	31	2.1	168	193	2 800	3 700	21312RH	21312RHK
	130	46	2.1	283	334	2 800	3 700	22312RHR	22312RHRK
65	120	31	1.5	178	211	2 900	3 800	22213RHR	22213RHRK
	140	33	2.1	194	232	2 600	3 400	21313RH	21313RHK
	140	48	2.1	305	360	2 600	3 400	22313RHR	22313RHRK
70	125	31	1.5	187	222	2 700	3 600	22214RHR	22214RHRK
	150	35	2.1	215	260	2 400	3 200	21314RH	21314RHK
	150	51	2.1	348	413	2 400	3 200	22314RHR	22314RHRK

[Remark] Standard cage types used for the above bearings are shown in Table 5 earlier in this section.

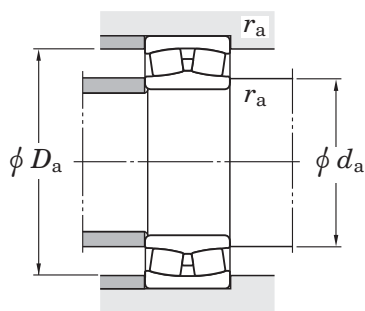

	Mounting dimensions (mm)			Constant <i>e</i>	Axial load factors			(Refer.) Mass (kg)	
	<i>d_a</i> min.	<i>D_a</i> max.	<i>r_a</i> max.		<i>Y₁</i>	<i>Y₂</i>	<i>Y₀</i>	Cylindrical bore	Tapered bore
	31	46	1	0.35	1.91	2.85	1.87	0.188	0.184
	36	56	1	0.33	2.04	3.04	2.00	0.296	0.290
	37	65	1	0.27	2.49	3.71	2.43	0.430	0.424
	42	65	1	0.32	2.09	3.11	2.04	0.459	0.449
	43.5	71.5	1.5	0.27	2.49	3.71	2.43	0.572	0.564
	47	73	1	0.28	2.37	3.53	2.32	0.602	0.591
	48.5	81.5	1.5	0.26	2.55	3.80	2.50	0.781	0.770
	48.5	81.5	1.5	0.37	1.83	2.72	1.79	1.08	1.06
	52	78	1	0.26	2.55	3.80	2.50	0.602	0.590
	53.5	91.5	1.5	0.26	2.62	3.90	2.56	1.05	1.04
	53.5	91.5	1.5	0.37	1.83	2.72	1.79	1.42	1.39
	57	83	1	0.24	2.79	4.15	2.73	0.648	0.634
	60	100	2	0.25	2.71	4.04	2.65	1.37	1.35
	60	100	2	0.36	1.85	2.76	1.81	1.92	1.88
	63.5	91.5	1.5	0.24	2.84	4.23	2.78	0.867	0.849
	65	110	2	0.25	2.71	4.03	2.65	1.69	1.67
	65	110	2	0.36	1.85	2.76	1.81	2.40	2.35
	68.5	101.5	1.5	0.25	2.74	4.08	2.68	1.19	1.17
	72	118	2	0.24	2.78	4.14	2.72	2.11	2.08
	72	118	2	0.36	1.86	2.77	1.82	3.06	2.99
	73.5	111.5	1.5	0.25	2.69	4.00	2.63	1.55	1.52
	77	128	2	0.24	2.83	4.21	2.76	2.62	2.58
	77	128	2	0.34	1.98	2.94	1.93	3.66	3.58
	78.5	116.5	1.5	0.24	2.87	4.27	2.80	1.64	1.61
	82	138	2	0.24	2.84	4.23	2.78	3.19	3.15
	82	138	2	0.34	1.98	2.94	1.93	4.45	4.36

Spherical roller bearings

d 75 ~ (110) mm

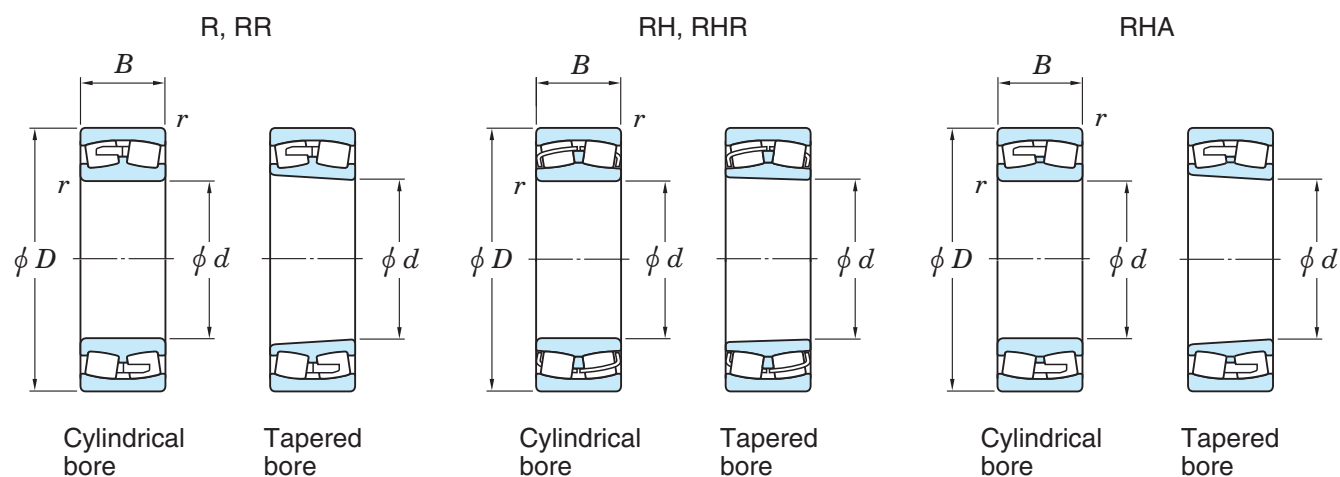

Boundary dimensions (mm)				Basic load ratings (kN)		Limiting speeds (min ⁻¹)		Bearing No.	
d	D	B	$r_{\min.}$	C_r	C_{Or}	Grease lub.	Oil lub.	Cylindrical bore	Tapered bore
75	130	31	1.5	193	236	2 600	3 400	22215RHR	22215RHRK
	160	37	2.1	246	298	2 200	3 000	21315RH	21315RHK
	160	55	2.1	393	473	2 200	3 000	22315RHR	22315RHRK
80	140	33	2	217	271	2 400	3 200	22216RHR	22216RHRK
	170	39	2.1	275	339	2 100	2 800	21316RH	21316RHK
	170	58	2.1	431	521	2 100	2 800	22316RHR	22316RHRK
85	150	36	2	258	324	2 200	3 000	22217RHR	22217RHRK
	180	41	3	300	372	2 000	2 600	21317RH	21317RHK
	180	60	3	481	586	2 000	2 600	22317RHR	22317RHRK
90	160	40	2	298	381	2 100	2 800	22218RHR	22218RHRK
	160	52.4	2	336	482	2 100	2 800	23218RH	23218RHK
	190	43	3	330	416	1 900	2 500	21318RH	21318RHK
	190	64	3	538	662	1 900	2 500	22318RHR	22318RHRK
95	170	43	2.1	334	422	2 000	2 600	22219RHR	22219RHRK
	200	45	3	362	461	1 800	2 300	21319RH	21319RHK
	200	67	3	586	726	1 800	2 300	22319RHR	22319RHRK
100	150	37	1.5	208	332	2 100	2 800	23020RH	23020RHK
	180	46	2.1	377	481	1 900	2 500	22220RHR	22220RHRK
	180	60.3	2.1	425	629	1 900	2 500	23220RH	23220RHK
	215	47	3	416	524	1 600	2 200	21320RH	21320RHK
	215	73	3	700	877	1 600	2 200	22320RHR	22320RHRK
110	170	45	2	300	486	1 900	2 500	23022RH	23022RHK
	180	56	2	385	605	1 800	2 400	23122RH	23122RHK
	180	69	2	469	778	1 800	2 400	24122RH	24122RHK30
	200	53	2.1	491	642	1 700	2 200	22222RHR	22222RHRK
	200	69.8	2.1	537	792	1 700	2 200	23222RH	23222RHK
	240	50	3	484	616	1 400	1 900	21322RH	21322RHK

[Remark] Standard cage types used for the above bearings are shown in Table 5 earlier in this section.

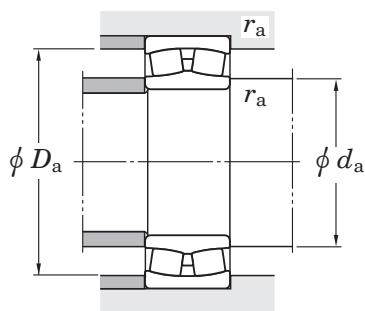

	Mounting dimensions (mm)			Constant <i>e</i>	Axial load factors			(Refer.) Mass (kg)	
	<i>d_a</i> min.	<i>D_a</i> max.	<i>r_a</i> max.		<i>Y₁</i>	<i>Y₂</i>	<i>Y₀</i>	Cylindrical bore	Tapered bore
	83.5	121.5	1.5	0.22	3.07	4.57	3.00	1.73	1.69
	87	148	2	0.24	2.87	4.27	2.80	3.81	3.76
	87	148	2	0.35	1.95	2.90	1.91	5.45	5.33
	90	130	2	0.22	3.07	4.57	3.00	2.17	2.13
	92	158	2	0.23	2.88	4.29	2.82	4.53	4.47
	92	158	2	0.35	1.95	2.90	1.91	6.44	6.30
	95	140	2	0.22	3.01	4.48	2.94	2.75	2.69
	99	166	2.5	0.23	2.89	4.33	2.83	5.32	5.25
	99	166	2.5	0.33	2.02	3.00	1.97	7.47	7.31
	100	150	2	0.24	2.79	4.15	2.73	3.50	3.43
	100	150	2	0.32	2.14	3.19	2.09	4.63	4.50
	104	176	2.5	0.23	2.91	4.30	2.84	6.20	6.11
	104	176	2.5	0.34	2.00	2.98	1.96	8.82	8.63
	107	158	2	0.24	2.76	4.11	2.70	4.24	4.15
	109	186	2.5	0.23	2.92	4.35	2.86	7.16	7.06
	109	186	2.5	0.33	2.02	3.00	1.97	10.2	9.98
	117	141	1.5	0.22	3.01	4.48	2.94	2.34	2.27
	112	168	2	0.25	2.74	4.08	2.68	5.11	5.00
	112	168	2	0.32	2.09	3.11	2.04	6.85	6.66
	114	201	2.5	0.22	3.02	4.49	2.95	8.79	8.68
	114	201	2.5	0.35	1.95	2.90	1.91	13.2	12.9
	120	160	2	0.24	2.84	4.23	2.78	3.85	3.74
	120	170	2	0.29	2.36	3.51	2.31	5.72	5.54
	120	170	2	0.37	1.84	2.74	1.80	6.98	6.87
	122	188	2	0.26	2.64	3.93	2.58	7.37	7.21
	122	188	2	0.34	1.99	2.96	1.94	9.76	9.48
	124	226	2.5	0.21	3.19	4.75	3.12	11.8	11.7

Spherical roller bearings

d (110) ~ (150) mm

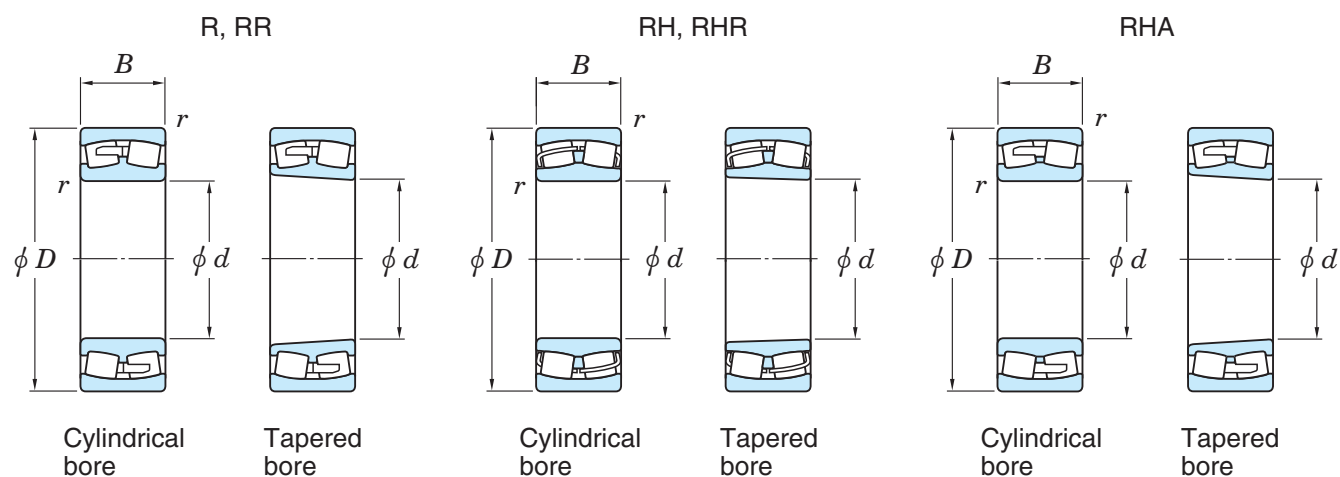

Boundary dimensions (mm)				Basic load ratings (kN)		Limiting speeds (min ⁻¹)		Bearing No.	
d	D	B	$r_{\text{min.}}$	C_r	C_{0r}	Grease lub.	Oil lub.	Cylindrical bore	Tapered bore
110	240	80	3	828	1 040	1 400	1 900	22322RHR	22322RHRK
120	180	46	2	314	524	1 700	2 300	23024RH	23024RHK
	180	60	2	397	709	1 700	2 300	24024RH	24024RHK30
	200	62	2	454	714	1 600	2 200	23124RH	23124RHK
	200	80	2	605	1 020	1 600	2 200	24124RH	24124RHK30
	215	58	2.1	565	764	1 500	2 000	22224RHR	22224RHRK
	215	76	2.1	616	956	1 500	2 100	23224RH	23224RHK
	260	86	3	896	1 130	1 300	1 800	22324RHR	22324RHRK
130	200	52	2	404	674	1 600	2 100	23026RH	23026RHK
	200	69	2	512	914	1 600	2 100	24026RH	24026RHK30
	210	64	2	494	799	1 500	2 000	23126RH	23126RHK
	210	80	2	620	1 080	1 500	2 000	24126RH	24126RHK30
	230	64	3	658	914	1 400	1 900	22226RHR	22226RHRK
	230	80	3	702	1 090	1 400	1 900	23226RH	23226RHK
	280	93	4	1 040	1 340	1 200	1 600	22326RHR	22326RHRK
140	210	53	2	422	723	1 500	2 000	23028RH	23028RHK
	210	69	2	524	957	1 500	2 000	24028RH	24028RHK30
	225	68	2.1	565	940	1 400	1 900	23128RH	23128RHK
	225	85	2.1	702	1 220	1 400	1 900	24128RH	24128RHK30
	250	68	3	759	1 030	1 300	1 700	22228RHR	22228RHRK
	250	88	3	811	1 290	1 300	1 700	23228RH	23228RHK
	300	102	4	1 170	1 570	1 100	1 500	22328RH	22328RHK
150	210	45	2	334	622	1 600	2 100	23930R	23930RK
	225	56	2.1	461	797	1 400	1 800	23030RH	23030RHK
	225	75	2.1	593	1 100	1 400	1 800	24030RH	24030RHK30
	250	80	2.1	717	1 230	1 300	1 700	23130RH	23130RHK
	250	100	2.1	915	1 590	1 300	1 700	24130RH	24130RHK30

[Remark] Standard cage types used for the above bearings are shown in Table 5 earlier in this section.

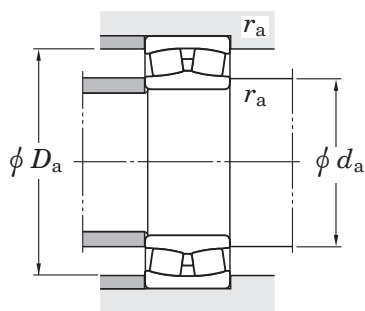

	Mounting dimensions (mm)			Con- stant e	Axial load factors			(Refer.) Mass (kg)	
	d_a min.	D_a max.	r_a max.		Y_1	Y_2	Y_0	Cylindrical bore	Tapered bore
	124	226	2.5	0.33	2.03	3.02	1.98	18.1	17.7
	130	170	2	0.23	2.95	4.40	2.89	4.20	4.07
	130	170	2	0.30	2.23	3.32	2.18	5.43	5.34
	130	190	2	0.29	2.34	3.49	2.29	7.98	7.74
	130	190	2	0.38	1.75	2.61	1.72	10.2	10.0
	132	203	2	0.26	2.60	3.87	2.54	9.31	9.10
	132	203	2	0.34	1.97	2.94	1.93	12.2	11.8
	134	246	2.5	0.33	2.03	3.02	1.98	22.8	22.3
	140	190	2	0.24	2.87	4.27	2.80	6.15	5.97
	140	190	2	0.32	2.14	3.18	2.09	8.03	7.90
	140	200	2	0.28	2.42	3.61	2.37	8.71	8.44
	140	200	2	0.36	1.90	2.83	1.86	10.8	10.6
	144	216	2.5	0.26	2.55	3.80	2.50	11.6	11.3
	144	216	2.5	0.33	2.05	3.05	2.00	14.4	14.0
	148	262	3	0.33	2.03	3.02	1.98	28.5	27.9
	150	200	2	0.23	2.98	4.44	2.92	6.62	6.42
	150	200	2	0.30	2.28	3.39	2.23	8.49	8.35
	152	213	2	0.28	2.45	3.65	2.40	10.6	10.3
	152	213	2	0.36	1.89	2.82	1.85	13.1	12.9
	154	236	2.5	0.26	2.60	3.87	2.54	14.5	14.2
	154	236	2.5	0.34	1.99	2.96	1.95	19.0	18.4
	158	282	3	0.35	1.95	2.90	1.90	35.7	34.9
	160	200	2	0.20	3.44	5.12	3.36	5.09	4.93
	162	213	2	0.22	3.04	4.53	2.97	8.01	7.77
	162	213	2	0.30	2.23	3.32	2.18	10.6	10.4
	162	238	2	0.30	2.24	3.34	2.19	16.4	15.9
	162	238	2	0.38	1.77	2.64	1.73	19.9	19.6

Spherical roller bearings

d (150) ~ (180) mm

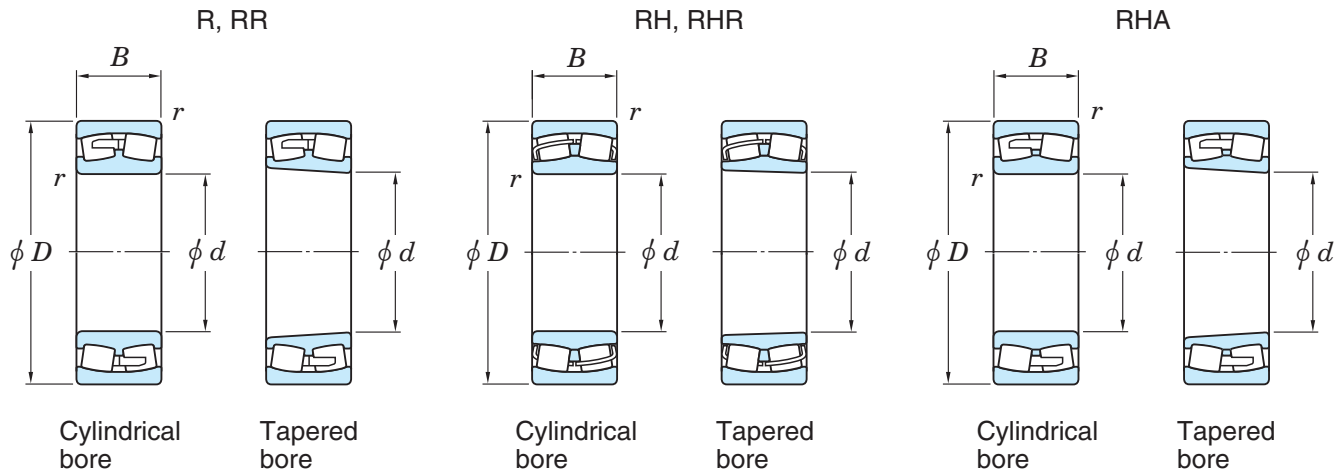

Boundary dimensions (mm)				Basic load ratings (kN)		Limiting speeds (min ⁻¹)		Bearing No.	
d	D	B	$r_{\min.}$	C_r	C_{Or}	Grease lub.	Oil lub.	Cylindrical bore	Tapered bore
150	270	73	3	865	1 200	1 200	1 600	22230RHR	22230RHRK
	270	96	3	959	1 540	1 200	1 600	23230RH	23230RHK
	320	108	4	1 230	1 600	1 200	1 500	22330R	22330RK
	320	108	4	1 290	1 740	1 200	1 500	22330RHA	22330RHAK
160	220	45	2	341	649	1 500	2 000	23932R	23932RK
	240	60	2.1	531	924	1 300	1 700	23032RH	23032RHK
	240	80	2.1	679	1 270	1 300	1 700	24032RH	24032RHK30
	270	86	2.1	848	1 430	1 200	1 600	23132RH	23132RHK
	290	80	3	885	1 270	1 200	1 600	22232R	22232RK
	290	80	3	897	1 320	1 200	1 600	22232RHA	22232RHAK
	290	104	3	1 030	1 650	1 200	1 600	23232R	23232RK
	290	104	3	1 100	1 780	1 200	1 600	23232RHA	23232RHAK
	340	114	4	1 380	1 790	1 100	1 400	22332R	22332RK
	340	114	4	1 420	1 940	1 100	1 400	22332RHA	22332RHAK
170	230	45	2	353	691	1 400	1 900	23934R	23934RK
	260	67	2.1	632	1 090	1 200	1 600	23034RH	23034RHK
	260	90	2.1	828	1 540	1 200	1 600	24034RH	24034RHK30
	280	88	2.1	916	1 550	1 100	1 500	23134RH	23134RHK
	280	109	2.1	1 050	1 820	1 600	1 200	24134RR	24134RRK30
	310	86	4	952	1 390	1 100	1 500	22234R	22234RK
	310	86	4	1 010	1 490	1 100	1 500	22234RHA	22234RHAK
	310	110	4	1 150	1 870	1 100	1 500	23234R	23234RK
	310	110	4	1 210	1 940	1 100	1 500	23234RHA	23234RHAK
	360	120	4	1 460	1 920	1 000	1 300	22334R	22334RK
360	120	4	1 590	2 200	1 000	1 300	22334RHA	22334RHAK	
180	250	52	2	479	939	1 300	1 700	23936R	23936RK
	280	74	2.1	768	1 330	1 100	1 400	23036RH	23036RHK

[Remark] Standard cage types used for the above bearings are shown in Table 5 earlier in this section.

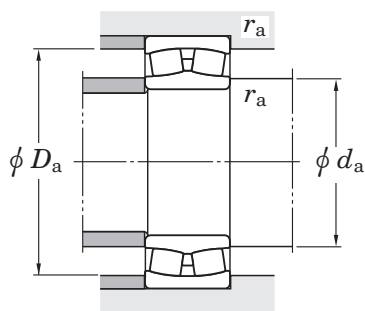

	Mounting dimensions (mm)			Con- stant <i>e</i>	Axial load factors			(Refer.) Mass (kg)	
	<i>d_a</i> min.	<i>D_a</i> max.	<i>r_a</i> max.		<i>Y</i> ₁	<i>Y</i> ₂	<i>Y</i> ₀	Cylindrical bore	Tapered bore
164	256	2.5	0.25	2.69	4.00	2.63	18.9	18.5	
164	256	2.5	0.34	1.96	2.93	1.92	24.5	23.8	
168	302	3	0.38	1.78	2.64	1.74	43.6	42.7	
168	302	3	0.35	1.93	2.87	1.88	40.3	39.4	
170	210	2	0.19	3.60	5.37	3.52	5.37	5.20	
172	228	2	0.22	3.01	4.48	2.94	9.74	9.44	
172	228	2	0.30	2.24	3.34	2.19	12.9	12.7	
172	258	2	0.30	2.22	3.30	2.17	20.8	20.2	
174	276	2.5	0.28	2.40	3.57	2.35	23.4	22.9	
174	276	2.5	0.27	2.49	3.71	2.44	21.9	21.4	
174	276	2.5	0.38	1.79	2.66	1.75	31.0	30.1	
174	276	2.5	0.36	1.87	2.78	1.83	29.4	28.5	
178	322	3	0.38	1.76	2.62	1.72	51.9	51.0	
178	322	3	0.35	1.94	2.89	1.90	48.0	47.1	
180	220	2	0.18	3.78	5.63	3.70	5.67	5.49	
182	248	2	0.23	2.90	4.31	2.83	13.2	12.8	
182	248	2	0.32	2.11	3.15	2.07	17.5	17.2	
182	268	2	0.29	2.30	3.43	2.25	21.9	21.2	
182	268	2	0.37	1.80	2.68	1.76	27.2	26.8	
188	292	3	0.29	2.29	3.41	2.24	29.0	28.4	
188	292	3	0.28	2.45	3.64	2.39	27.1	26.5	
188	292	3	0.37	1.81	2.70	1.77	37.5	36.5	
188	292	3	0.36	1.89	2.82	1.85	35.6	34.6	
188	342	3	0.38	1.77	2.64	1.73	62.0	60.8	
188	342	3	0.35	1.95	2.91	1.91	57.3	56.1	
190	240	2	0.19	3.55	5.29	3.48	8.22	7.97	
192	268	2	0.24	2.84	4.23	2.78	17.4	16.9	

Spherical roller bearings

d (180) ~ (200) mm

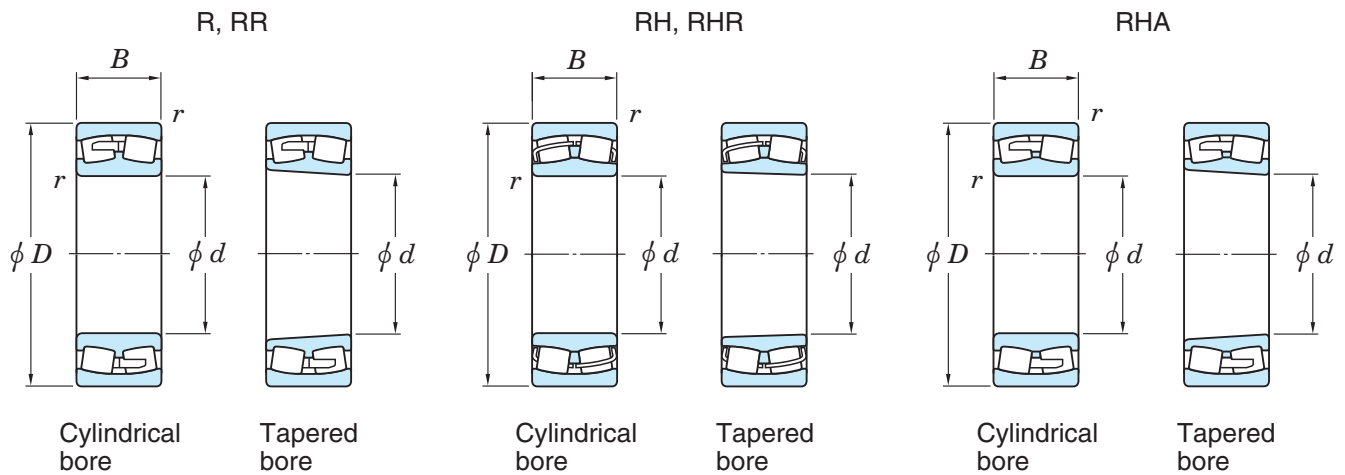

Boundary dimensions (mm)				Basic load ratings (kN)		Limiting speeds (min ⁻¹)		Bearing No.	
d	D	B	$r_{\min.}$	C_r	C_{Or}	Grease lub.	Oil lub.	Cylindrical bore	Tapered bore
180	280	100	2.1	933	1 710	1 600	1 200	24036RR	24036RRK30
	300	96	3	1 000	1 800	1 100	1 500	23136R	23136RK
	300	96	3	1 060	1 790	1 100	1 500	23136RHA	23136RHAK
	300	118	3	1 220	2 120	1 100	1 500	24136RR	24136RRK30
	300	118	3	1 250	2 240	1 100	1 500	24136RHA	24136RHAK30
	320	86	4	978	1 450	1 100	1 400	22236R	22236RK
	320	86	4	1 060	1 610	1 100	1 400	22236RHA	22236RHAK
	320	112	4	1 190	1 980	1 100	1 400	23236R	23236RK
	320	112	4	1 320	2 170	1 100	1 400	23236RHA	23236RHAK
	380	126	4	1 740	2 360	920	1 200	22336R	22336RK
	380	126	4	1 740	2 410	930	1 200	22336RHA	22336RHAK
	190	260	52	2	486	969	1 200	1 600	23938R
290		75	2.1	736	1 370	1 100	1 500	23038R	23038RK
290		75	2.1	789	1 430	1 100	1 500	23038RHA	23038RHAK
290		100	2.1	989	1 840	1 100	1 500	24038RR	24038RRK30
290		100	2.1	1 010	1 920	1 100	1 500	24038RHA	24038RHAK30
320		104	3	1 090	2 000	1 000	1 400	23138R	23138RK
320		104	3	1 210	2 080	1 000	1 400	23138RHA	23138RHAK
320		128	3	1 400	2 470	1 000	1 400	24138RR	24138RRK30
320		128	3	1 460	2 630	1 000	1 400	24138RHA	24138RHAK30
340		92	4	1 110	1 730	1 000	1 300	22238R	22238RK
340		92	4	1 150	1 770	1 000	1 300	22238RHA	22238RHAK
340		120	4	1 410	2 210	1 000	1 300	23238R	23238RK
340		120	4	1 490	2 470	990	1 300	23238RHA	23238RHAK
400		132	5	1 900	2 610	880	1 200	22338R	22338RK
400		132	5	1 940	2 810	870	1 200	22338RHA	22338RHAK
200	280	60	2.1	601	1 190	1 100	1 500	23940R	23940RK
	310	82	2.1	890	1 670	1 000	1 400	23040R	23040RK
	310	82	2.1	940	1 680	1 100	1 400	23040RHA	23040RHAK

[Remark] Standard cage types used for the above bearings are shown in Table 5 earlier in this section.

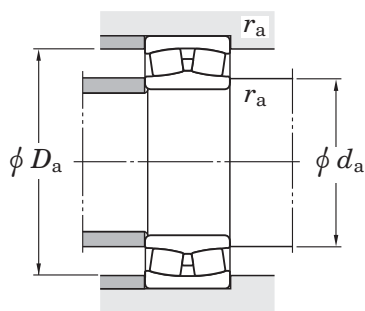

	Mounting dimensions (mm)			Con- stant e	Axial load factors			(Refer.) Mass (kg)	
	d_a min.	D_a max.	r_a max.		Y_1	Y_2	Y_0	Cylindrical bore	Tapered bore
	192	268	2	0.34	2.00	2.98	1.96	23.4	23.0
	194	286	2.5	0.33	2.04	3.04	2.00	28.4	27.5
	194	286	2.5	0.31	2.19	3.25	2.14	26.5	25.6
	194	286	2.5	0.38	1.78	2.65	1.74	34.4	33.9
	194	286	2.5	0.38	1.79	2.66	1.75	31.8	31.2
	198	302	3	0.28	2.37	3.53	2.32	30.5	29.8
	198	302	3	0.26	2.55	3.80	2.50	28.5	27.8
	198	302	3	0.37	1.84	2.74	1.80	39.8	38.6
	198	302	3	0.34	1.97	2.93	1.92	37.7	36.5
	198	362	3	0.36	1.89	2.81	1.84	71.4	69.9
	198	362	3	0.34	1.97	2.94	1.93	66.0	64.5
	200	250	2	0.18	3.69	5.50	3.61	8.40	8.10
	202	278	2	0.25	2.67	3.97	2.61	18.8	18.2
	202	278	2	0.25	2.75	4.10	2.69	17.2	16.6
	202	278	2	0.33	2.06	3.07	2.02	24.5	24.1
	202	278	2	0.32	2.14	3.19	2.09	22.4	22.0
	204	306	2.5	0.34	1.96	2.92	1.92	35.5	34.4
	204	306	2.5	0.31	2.14	3.19	2.10	33.2	32.1
	204	306	2.5	0.39	1.74	2.59	1.70	43.0	42.4
	204	306	2.5	0.38	1.76	2.63	1.72	40.1	39.5
	208	322	3	0.29	2.29	3.41	2.24	37.4	36.6
	208	322	3	0.27	2.52	3.76	2.46	34.9	34.1
	208	322	3	0.36	1.87	2.79	1.83	47.4	46.0
	208	322	3	0.35	1.94	2.89	1.90	44.9	43.5
	212	378	4	0.38	1.79	2.66	1.75	84.1	82.4
	212	378	4	0.34	1.99	2.97	1.95	77.7	76.0
	212	268	2	0.20	3.44	5.13	3.37	12.0	11.6
	212	298	2	0.26	2.62	3.90	2.56	24.1	23.4
	212	298	2	0.25	2.68	3.99	2.62	22.0	21.3

Spherical roller bearings

d (200) ~ (240) mm

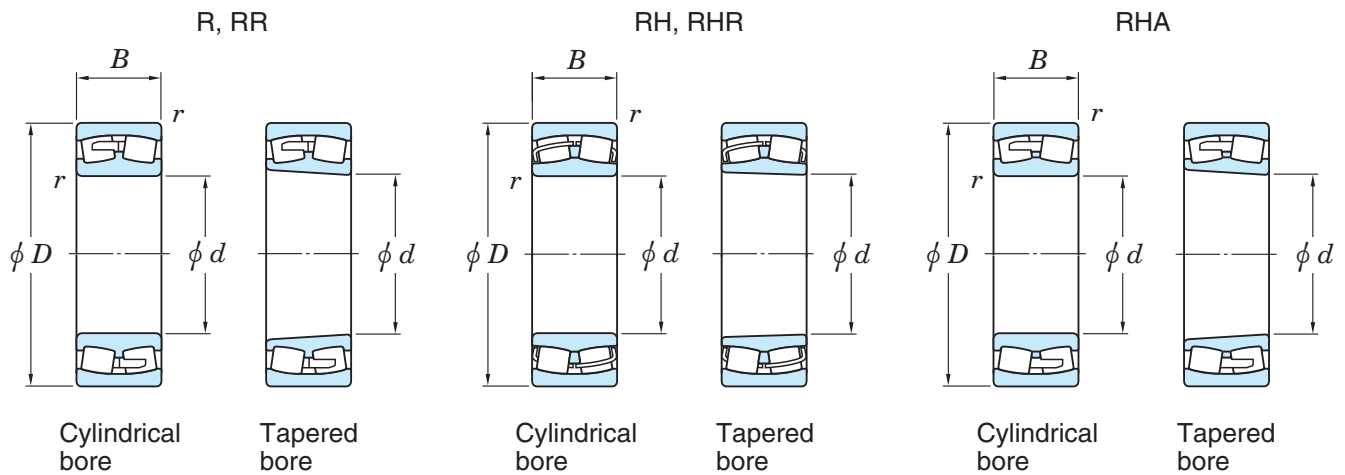

Boundary dimensions (mm)				Basic load ratings (kN)		Limiting speeds (min ⁻¹)		Bearing No.	
d	D	B	$r_{\min.}$	C_r	C_{0r}	Grease lub.	Oil lub.	Cylindrical bore	Tapered bore
200	310	109	2.1	1 140	2 110	1 100	1 400	24040RR	24040RRK30
	310	109	2.1	1 180	2 230	1 100	1 400	24040RHA	24040RHAK30
	340	112	3	1 240	2 250	980	1 300	23140R	23140RK
	340	112	3	1 380	2 340	970	1 300	23140RHA	23140RHAK
	340	140	3	1 620	2 820	990	1 300	24140RR	24140RRK30
	340	140	3	1 660	2 970	990	1 300	24140RHA	24140RHAK30
	360	98	4	1 230	1 930	930	1 200	22240R	22240RK
	360	98	4	1 310	2 030	940	1 300	22240RHA	22240RHAK
	360	128	4	1 550	2 610	940	1 300	23240R	23240RK
	360	128	4	1 660	2 780	930	1 200	23240RHA	23240RHAK
	420	138	5	2 010	2 750	830	1 100	22340R	22340RK
	420	138	5	2 060	2 920	820	1 100	22340RHA	22340RHAK
220	300	60	2.1	634	1 300	1 000	1 400	23944R	23944RK
	340	90	3	984	1 890	940	1 300	23044R	23044RK
	340	90	3	1 090	1 950	940	1 200	23044RHA	23044RHAK
	340	118	3	1 320	2 480	950	1 300	24044RR	24044RRK30
	340	118	3	1 380	2 630	950	1 300	24044RHA	24044RHAK30
	370	120	4	1 440	2 700	880	1 200	23144R	23144RK
	370	120	4	1 590	2 790	870	1 200	23144RHA	23144RHAK
	370	150	4	1 880	3 390	880	1 200	24144RR	24144RRK30
	370	150	4	1 920	3 550	880	1 200	24144RHA	24144RHAK30
	400	108	4	1 560	2 400	820	1 100	22244R	22244RK
	400	108	4	1 590	2 440	820	1 100	22244RHA	22244RHAK
	400	144	4	1 880	3 200	830	1 100	23244R	23244RK
	400	144	4	2 020	3 350	810	1 100	23244RHA	23244RHAK
	460	145	5	2 380	3 380	720	960	22344R	22344RK
	460	145	5	2 370	3 470	730	970	22344RHA	22344RHAK
240	320	60	2.1	651	1 380	940	1 300	23948R	23948RK

[Remark] Standard cage types used for the above bearings are shown in Table 5 earlier in this section.

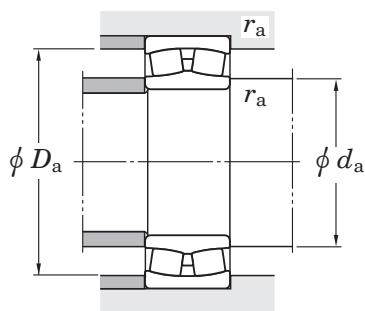

	Mounting dimensions (mm)			Con- stant e	Axial load factors			(Refer.) Mass (kg)	
	d_a min.	D_a max.	r_a max.		Y_1	Y_2	Y_0	Cylindrical bore	Tapered bore
	212	298	2	0.33	2.02	3.00	1.97	31.2	30.7
	212	298	2	0.33	2.06	3.07	2.02	28.5	28.0
	214	326	2.5	0.34	1.97	2.94	1.93	43.7	42.4
	214	326	2.5	0.32	2.10	3.13	2.06	40.8	39.5
	214	326	2.5	0.40	1.68	2.49	1.64	53.3	52.5
	214	326	2.5	0.41	1.65	2.46	1.62	49.5	48.7
	218	342	3	0.30	2.26	3.36	2.21	45.0	44.0
	218	342	3	0.27	2.50	3.72	2.45	42.0	41.0
	218	342	3	0.38	1.79	2.67	1.75	58.1	56.4
	218	342	3	0.35	1.92	2.86	1.88	55.1	53.4
	222	398	4	0.38	1.80	2.68	1.76	95.4	93.5
	222	398	4	0.34	1.99	2.97	1.95	88.1	86.2
	232	288	2	0.18	3.70	5.50	3.61	13.0	12.6
	234	326	2.5	0.26	2.55	3.80	2.50	31.5	30.6
	234	326	2.5	0.25	2.69	4.01	2.63	28.8	27.9
	234	326	2.5	0.33	2.04	3.04	2.00	40.5	39.8
	234	326	2.5	0.33	2.08	3.09	2.03	37.0	36.4
	238	352	3	0.34	2.00	2.98	1.96	54.8	53.2
	238	352	3	0.31	2.15	3.20	2.10	51.2	49.6
	238	352	3	0.39	1.71	2.55	1.67	67.3	66.2
	238	352	3	0.40	1.69	2.52	1.65	62.0	61.0
	238	382	3	0.28	2.40	3.57	2.34	63.0	61.7
	238	382	3	0.27	2.52	3.76	2.47	58.8	57.5
	238	382	3	0.39	1.71	2.55	1.68	81.6	79.2
	238	382	3	0.36	1.89	2.81	1.85	77.4	75.0
	242	438	4	0.34	2.00	2.99	1.96	124	122
	242	438	4	0.32	2.08	3.09	2.03	115	113
	252	308	2	0.17	3.95	5.88	3.86	14.0	13.5

Spherical roller bearings

d (240) ~ 260 mm

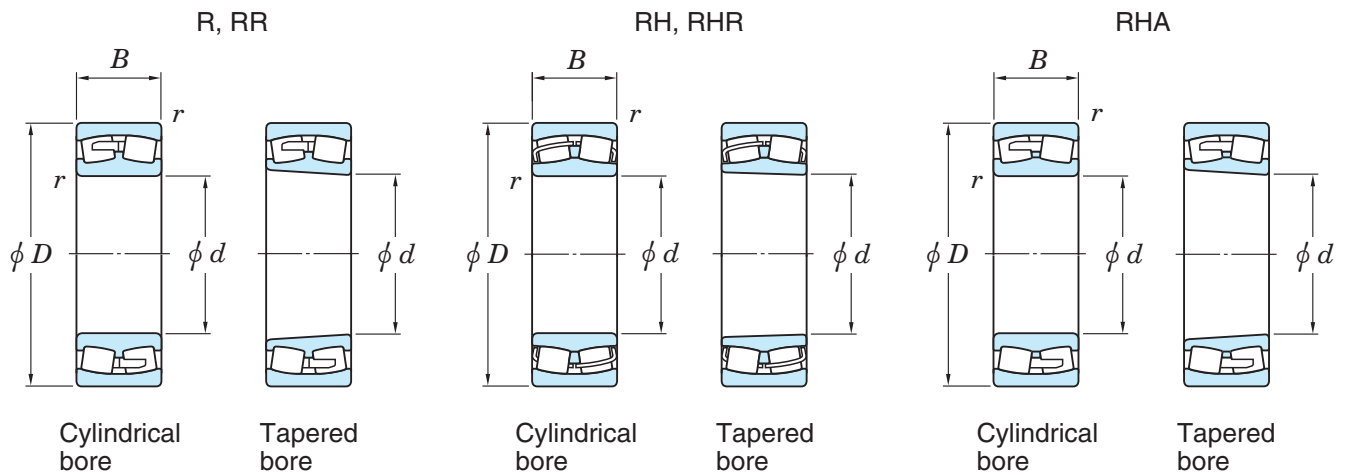

Boundary dimensions (mm)				Basic load ratings (kN)		Limiting speeds (min ⁻¹)		Bearing No.	
d	D	B	$r_{\min.}$	C_r	C_{Or}	Grease lub.	Oil lub.	Cylindrical bore	Tapered bore
240	360	92	3	1 100	2 170	860	1 100	23048R	23048RK
	360	92	3	1 170	2 180	860	1 100	23048RHA	23048RHAK
	360	118	3	1 390	2 710	870	1 200	24048RR	24048RRK30
	360	118	3	1 430	2 840	870	1 200	24048RHA	24048RHAK30
	400	128	4	1 630	3 080	790	1 100	23148R	23148RK
	400	128	4	1 810	3 200	790	1 000	23148RHA	23148RHAK
	400	160	4	2 100	3 850	800	1 100	24148RR	24148RRK30
	400	160	4	2 200	4 130	800	1 100	24148RHA	24148RHAK30
	440	120	4	1 920	2 940	730	970	22248R	22248RK
	440	120	4	1 920	2 990	730	970	22248RHA	22248RHAK
	440	160	4	2 340	3 990	730	970	23248R	23248RK
	440	160	4	2 460	4 130	730	970	23248RHA	23248RHAK
	500	155	5	2 610	4 020	650	870	22348R	22348RK
	500	155	5	2 720	3 990	650	870	22348RHA	22348RHAK
	260	360	75	2.1	914	1 880	820	1 100	23952R
400		104	4	1 330	2 570	760	1 000	23052R	23052RK
400		104	4	1 470	2 720	760	1 000	23052RHA	23052RHAK
400		140	4	1 810	3 570	770	1 000	24052RR	24052RRK30
400		140	4	1 860	3 670	770	1 000	24052RHA	24052RHAK30
440		144	4	2 100	3 860	710	940	23152R	23152RK
440		144	4	2 220	4 000	700	930	23152RHA	23152RHAK
440		180	4	2 590	4 700	720	950	24152RR	24152RRK30
440		180	4	2 650	4 950	720	950	24152RHA	24152RHAK30
480		130	5	2 240	3 460	650	870	22252R	22252RK
480		130	5	2 230	3 430	650	870	22252RHA	22252RHAK
480		174	5	2 750	4 640	640	860	23252R	23252RK
480		174	5	2 870	4 900	650	860	23252RHA	23252RHAK
540		165	6	2 830	4 380	590	780	22352R	22352RK
540		165	6	3 120	4 620	580	780	22352RHA	22352RHAK

[Remark] Standard cage types used for the above bearings are shown in Table 5 earlier in this section.

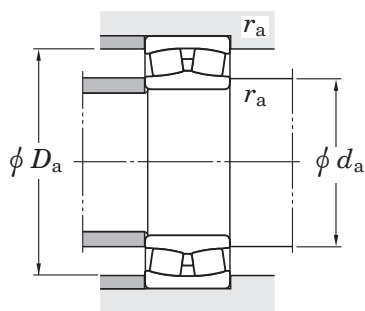

	Mounting dimensions (mm)			Con- stant <i>e</i>	Axial load factors			(Refer.) Mass (kg)	
	<i>d_a</i> min.	<i>D_a</i> max.	<i>r_a</i> max.		<i>Y₁</i>	<i>Y₂</i>	<i>Y₀</i>	Cylindrical bore	Tapered bore
	254	346	2.5	0.25	2.71	4.04	2.65	34.9	33.8
	254	346	2.5	0.24	2.83	4.21	2.77	31.9	30.9
	254	346	2.5	0.31	2.20	3.27	2.15	43.5	42.9
	254	346	2.5	0.30	2.24	3.33	2.19	39.6	39.0
	258	382	3	0.33	2.05	3.05	2.00	67.6	65.6
	258	382	3	0.31	2.19	3.25	2.14	63.1	61.1
	258	382	3	0.39	1.75	2.60	1.71	82.7	81.4
	258	382	3	0.39	1.72	2.56	1.68	76.6	75.3
	258	422	3	0.29	2.35	3.50	2.30	85.0	83.2
	258	422	3	0.27	2.49	3.71	2.43	79.4	77.6
	258	422	3	0.39	1.73	2.57	1.69	110	107
	258	422	3	0.36	1.87	2.78	1.83	104	101
	262	478	4	0.35	1.94	2.89	1.90	157	154
	262	478	4	0.32	2.12	3.16	2.07	145	142
	272	348	2	0.19	3.54	5.27	3.46	24.0	23.3
	278	382	3	0.25	2.65	3.95	2.59	50.7	49.3
	278	382	3	0.25	2.75	4.10	2.69	46.3	44.9
	278	382	3	0.33	2.02	3.01	1.98	66.3	65.2
	278	382	3	0.33	2.06	3.07	2.02	60.3	59.4
	278	422	3	0.33	2.03	3.02	1.98	93.6	90.8
	278	422	3	0.32	2.12	3.16	2.08	87.4	84.6
	278	422	3	0.40	1.69	2.51	1.65	114	112
	278	422	3	0.41	1.66	2.47	1.62	106	105
	282	458	4	0.28	2.40	3.57	2.35	110	108
	282	458	4	0.27	2.50	3.72	2.44	103	101
	282	458	4	0.40	1.69	2.51	1.65	144	140
	282	458	4	0.36	1.87	2.78	1.83	137	133
	288	512	5	0.35	1.94	2.89	1.90	196	192
	288	512	5	0.31	2.15	3.21	2.11	181	177

Spherical roller bearings

d 280 ~ 300 mm

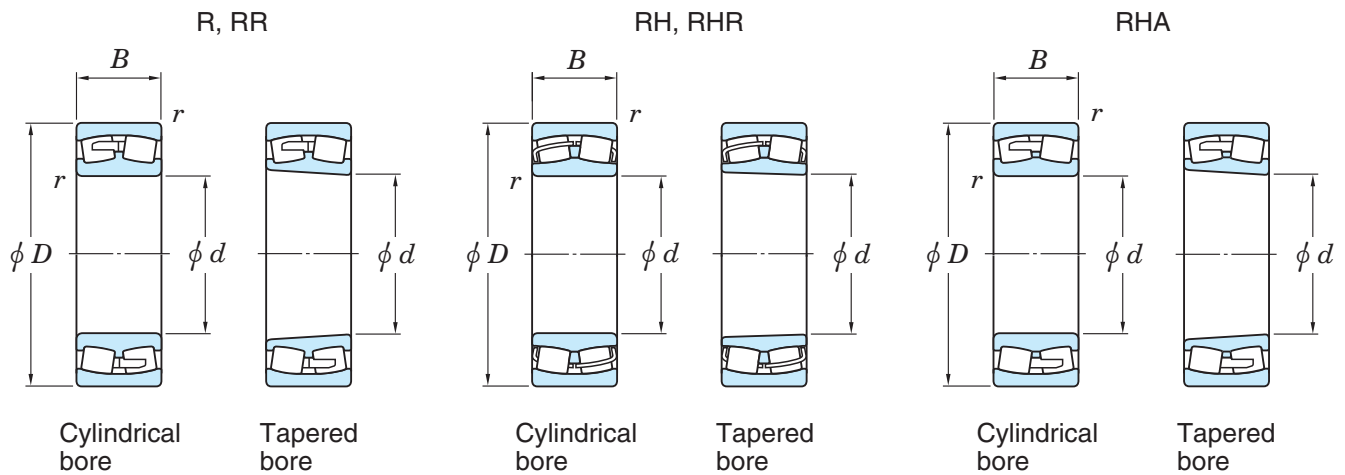

Boundary dimensions (mm)				Basic load ratings (kN)		Limiting speeds (min ⁻¹)		Bearing No.	
d	D	B	$r_{\min.}$	C_r	C_{0r}	Grease lub.	Oil lub.	Cylindrical bore	Tapered bore
280	380	75	2.1	928	1 960	760	1 000	23956R	23956RK
	420	106	4	1 430	2 860	710	950	23056R	23056RK
	420	106	4	1 550	2 950	700	940	23056RHA	23056RHAK
	420	140	4	1 890	3 780	710	950	24056RR	24056RRK30
	420	140	4	1 960	4 000	710	950	24056RHA	24056RHAK30
	460	146	5	2 140	4 280	660	880	23156R	23156RK
	460	146	5	2 340	4 290	650	870	23156RHA	23156RHAK
	460	180	5	2 700	5 140	660	880	24156RR	24156RRK30
	460	180	5	2 740	5 240	660	880	24156RHA	24156RHAK30
	500	130	5	2 100	3 380	610	810	22256R	22256RK
	500	130	5	2 320	3 670	610	810	22256RHA	22256RHAK
	500	176	5	2 690	4 910	610	820	23256R	23256RK
	500	176	5	3 010	5 300	600	800	23256RHA	23256RHAK
	580	175	6	3 150	4 910	530	710	22356R	22356RK
	580	175	6	3 510	5 260	530	700	22356RHA	22356RHAK
	300	420	90	3	1 280	2 610	680	910	23960R
460		118	4	1 750	3 480	630	840	23060R	23060RK
460		118	4	1 940	3 700	630	840	23060RHA	23060RHAK
460		160	4	2 350	4 690	640	850	24060RR	24060RRK30
460		160	4	2 420	4 910	640	850	24060RHA	24060RHAK30
500		160	5	2 490	4 850	590	790	23160R	23160RK
500		160	5	2 730	4 970	580	780	23160RHA	23160RHAK
500		200	5	3 320	6 280	590	790	24160RR	24160RRK30
500		200	5	3 320	6 420	590	790	24160RHA	24160RHAK30
540		140	5	2 690	4 330	550	740	22260R	22260RK
540		140	5	2 650	4 360	550	740	22260RHA	22260RHAK
540		192	5	3 430	5 910	540	720	23260R	23260RK
540		192	5	3 540	6 310	540	720	23260RHA	23260RHAK
620		185	7.5	3 910	5 430	470	630	22360R	22360RK

[Remark] Standard cage types used for the above bearings are shown in Table 5 earlier in this section.

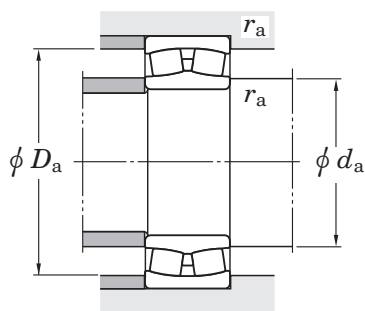

	Mounting dimensions (mm)			Con- stant <i>e</i>	Axial load factors			(Refer.) Mass (kg)	
	<i>d_a</i> min.	<i>D_a</i> max.	<i>r_a</i> max.		<i>Y₁</i>	<i>Y₂</i>	<i>Y₀</i>	Cylindrical bore	Tapered bore
	292	368	2	0.18	3.74	5.57	3.66	26.0	25.2
	298	402	3	0.25	2.74	4.08	2.68	54.5	52.9
	298	402	3	0.24	2.87	4.27	2.80	49.8	48.2
	298	402	3	0.31	2.15	3.21	2.11	70.2	69.1
	298	402	3	0.31	2.20	3.28	2.15	64.0	62.9
	302	438	4	0.33	2.04	3.03	1.99	100	96.9
	302	438	4	0.30	2.22	3.30	2.17	93.4	90.3
	302	438	4	0.38	1.79	2.67	1.75	122	120
	302	438	4	0.38	1.76	2.62	1.72	113	112
	302	478	4	0.28	2.42	3.60	2.37	114	112
	302	478	4	0.26	2.64	3.93	2.58	106	104
	302	478	4	0.37	1.83	2.72	1.79	153	149
	302	478	4	0.35	1.95	2.91	1.91	145	141
	308	552	5	0.34	1.98	2.95	1.93	229	225
	308	552	5	0.31	2.19	3.25	2.14	212	208
	314	406	2.5	0.20	3.42	5.09	3.34	40.0	38.8
	318	442	3	0.25	2.69	4.00	2.63	75.8	73.7
	318	442	3	0.24	2.79	4.16	2.73	68.9	66.8
	318	442	3	0.33	2.04	3.04	2.00	99.5	97.9
	318	442	3	0.32	2.09	3.11	2.04	90.7	89.1
	322	478	4	0.33	2.02	3.01	1.98	132	128
	322	478	4	0.31	2.18	3.25	2.13	123	119
	322	478	4	0.40	1.67	2.49	1.63	162	160
	322	478	4	0.39	1.72	2.56	1.68	150	148
	322	518	4	0.27	2.48	3.69	2.43	145	142
	322	518	4	0.26	2.62	3.90	2.56	135	132
	322	518	4	0.37	1.83	2.72	1.79	197	192
	322	518	4	0.35	1.93	2.88	1.89	187	182
	336	584	6	0.32	2.09	3.10	2.04	289	284

Spherical roller bearings

d 320 ~ (360) mm

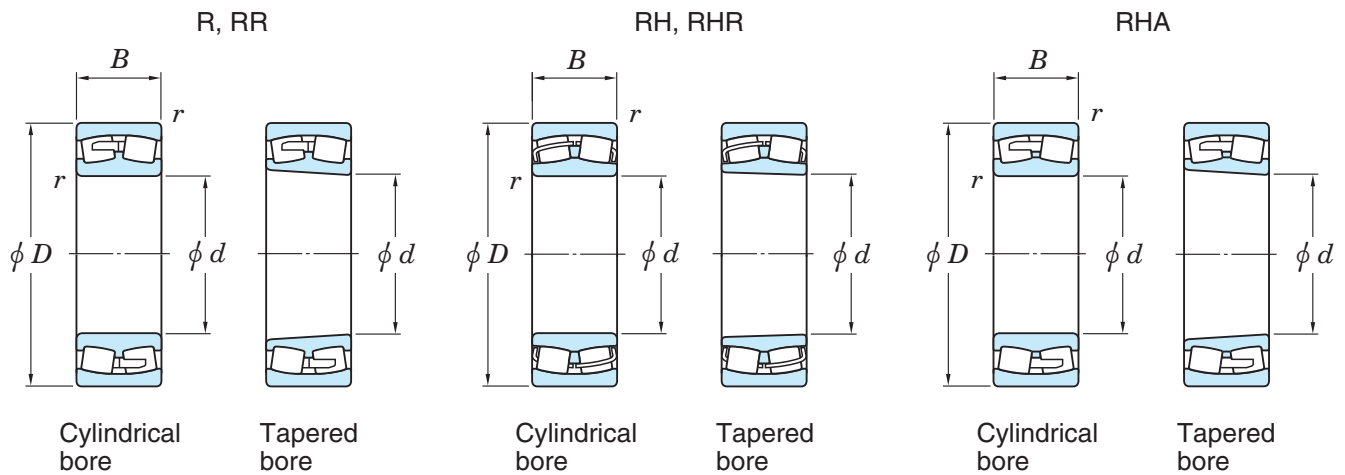

Boundary dimensions (mm)				Basic load ratings (kN)		Limiting speeds (min ⁻¹)		Bearing No.	
d	D	B	$r_{\min.}$	C_r	C_{0r}	Grease lub.	Oil lub.	Cylindrical bore	Tapered bore
320	440	90	3	1 330	2 870	630	840	23964R	23964RK
	480	121	4	1 830	3 740	590	790	23064R	23064RK
	480	121	4	1 980	3 850	590	780	23064RHA	23064RHAK
	480	160	4	2 400	4 920	590	790	24064RR	24064RRK30
	480	160	4	2 510	5 230	590	790	24064RHA	24064RHAK30
	540	176	5	2 900	5 700	530	700	23164R	23164RK
	540	176	5	3 220	5 960	530	700	23164RHA	23164RHAK
	540	218	5	3 730	6 950	530	710	24164RR	24164RRK30
	540	218	5	3 760	7 190	530	710	24164RHA	24164RHAK30
	580	150	5	2 730	4 540	490	660	22264R	22264RK
	580	208	5	3 630	6 550	500	670	23264R	23264RK
	580	208	5	4 010	7 030	490	650	23264RHA	23264RHAK
340	460	90	3	1 350	2 980	590	790	23968R	23968RK
	520	133	5	2 130	4 330	530	710	23068R	23068RK
	520	133	5	2 330	4 470	530	710	23068RHA	23068RHAK
	520	180	5	2 920	5 970	530	710	24068RR	24068RRK30
	520	180	5	3 040	6 330	530	710	24068RHA	24068RHAK30
	580	190	5	3 280	6 430	480	640	23168R	23168RK
	580	190	5	3 680	6 720	480	640	23168RHA	23168RHAK
	580	243	5	4 440	8 400	490	650	24168RR	24168RRK30
	580	243	5	4 540	8 810	490	650	24168RHA	24168RHAK30
	620	165	6	3 550	5 430	440	590	22268R	22268RK
	620	224	6	4 090	7 560	450	600	23268R	23268RK
	620	224	6	4 550	8 030	440	590	23268RHA	23268RHAK
360	480	90	3	1 360	3 060	550	730	23972R	23972RK
	540	134	5	2 280	4 800	500	660	23072R	23072RK
	540	134	5	2 420	4 770	500	660	23072RHA	23072RHAK
	540	180	5	3 030	6 300	500	660	24072RR	24072RRK30
	540	180	5	3 120	6 620	500	660	24072RHA	24072RHAK30

[Remark] Standard cage types used for the above bearings are shown in Table 5 earlier in this section.

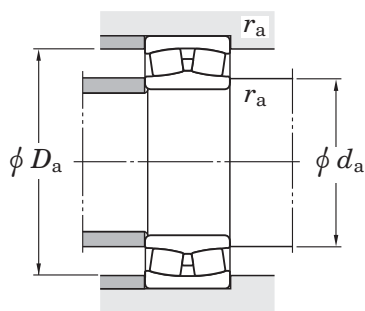

	Mounting dimensions (mm)			Con-stant e	Axial load factors			(Refer.) Mass (kg)	
	d_a min.	D_a max.	r_a max.		Y_1	Y_2	Y_0	Cylindrical bore	Tapered bore
	334	426	2.5	0.19	3.61	5.38	3.53	43.0	41.7
	338	462	3	0.24	2.76	4.11	2.70	81.2	78.8
	338	462	3	0.24	2.87	4.27	2.80	74.5	72.1
	338	462	3	0.31	2.16	3.22	2.11	105	103
	338	462	3	0.31	2.21	3.29	2.16	93.4	91.4
	342	518	4	0.33	2.04	3.04	2.00	171	166
	342	518	4	0.32	2.13	3.17	2.08	160	155
	342	518	4	0.39	1.72	2.56	1.68	208	205
	342	518	4	0.40	1.70	2.52	1.66	199	196
	342	558	4	0.28	2.41	3.59	2.35	175	171
	342	558	4	0.38	1.76	2.62	1.72	249	242
	342	558	4	0.36	1.90	2.83	1.86	236	229
	354	446	2.5	0.18	3.82	5.69	3.74	45.0	43.6
	362	498	4	0.25	2.69	4.00	2.63	108	105
	362	498	4	0.24	2.80	4.18	2.74	98.7	95.7
	362	498	4	0.33	2.06	3.06	2.01	142	140
	362	498	4	0.32	2.11	3.14	2.06	130	128
	362	558	4	0.34	1.97	2.93	1.93	216	210
	362	558	4	0.32	2.11	3.14	2.06	202	196
	362	558	4	0.41	1.64	2.45	1.61	270	266
	362	558	4	0.42	1.61	2.39	1.57	259	255
	368	592	5	0.28	2.43	3.61	2.37	221	216
	368	592	5	0.38	1.77	2.63	1.73	306	297
	368	592	5	0.36	1.88	2.81	1.84	290	281
	374	466	2.5	0.17	3.95	5.88	3.86	46.5	45.0
	382	518	4	0.24	2.76	4.11	2.70	115	111
	382	518	4	0.23	2.92	4.34	2.85	105	101
	382	518	4	0.31	2.15	3.21	2.11	149	147
	382	518	4	0.30	2.22	3.30	2.17	135	133

Spherical roller bearings

d (360) ~ (400) mm

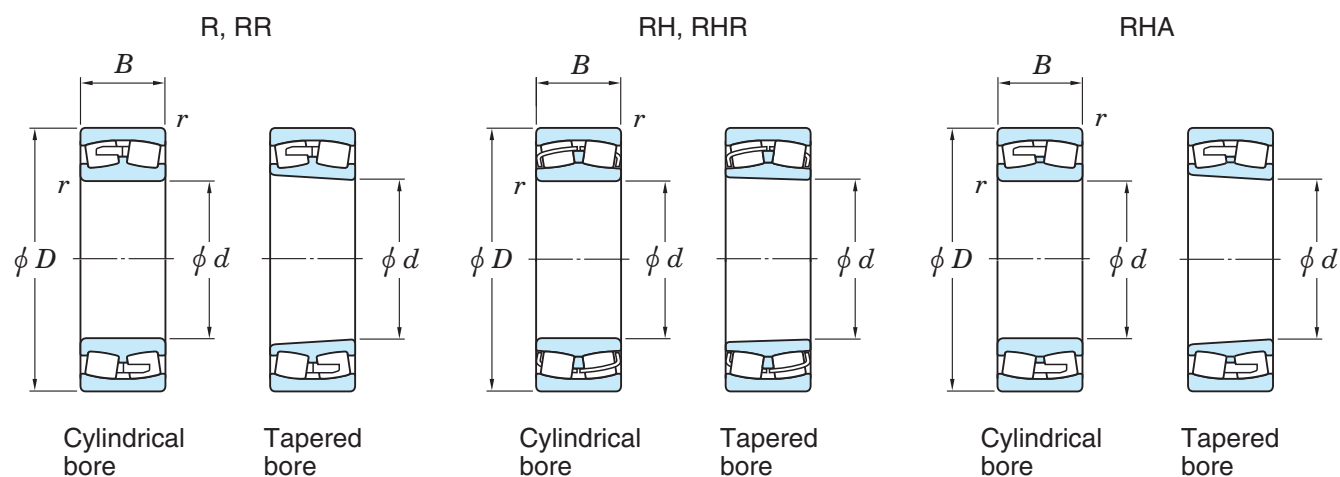

Boundary dimensions (mm)				Basic load ratings (kN)		Limiting speeds (min ⁻¹)		Bearing No.	
d	D	B	$r_{\text{min.}}$	C_r	C_{0r}	Grease lub.	Oil lub.	Cylindrical bore	Tapered bore
360	600	192	5	3 770	7 040	440	590	23172R	23172RK
	600	192	5	3 850	7 210	450	590	23172RHA	23172RHAK
	600	243	5	4 080	7 690	450	600	24172R	24172RK30
	600	243	5	4 600	9 180	460	610	24172RHA	24172RHAK30
	650	170	6	3 770	5 830	410	550	22272R	22272RK
	650	232	6	4 850	8 810	410	540	23272R	23272RK
	650	232	6	4 960	9 050	410	550	23272RHA	23272RHAK
380	520	106	4	1 780	3 940	500	660	23976R	23976RK
	560	135	5	2 320	4 970	470	630	23076R	23076RK
	560	135	5	2 520	5 080	460	620	23076RHA	23076RHAK
	560	180	5	3 110	6 590	470	620	24076RR	24076RRK30
	560	180	5	3 190	6 910	470	620	24076RHA	24076RHAK30
	620	194	5	3 590	7 320	420	560	23176R	23176RK
	620	194	5	4 000	7 700	420	560	23176RHA	23176RHAK
	620	243	5	4 220	8 220	430	570	24176R	24176RK30
	620	243	5	4 830	9 840	420	560	24176RHA	24176RHAK30
	680	240	6	5 200	9 500	380	500	23276R	23276RK
	680	240	6	5 320	9 760	380	510	23276RHA	23276RHAK
400	540	106	4	1 880	4 300	470	620	23980R	23980RK
	600	148	5	2 710	5 790	420	560	23080R	23080RK
	600	148	5	2 930	5 860	420	560	23080RHA	23080RHAK
	600	200	5	3 830	8 110	430	570	24080R	24080RK30
	600	200	5	3 780	8 140	420	570	24080RHA	24080RHAK30
	650	200	6	4 110	7 780	390	520	23180R	23180RK
	650	200	6	4 310	8 300	390	520	23180RHA	23180RHAK
	650	250	6	4 640	9 140	390	530	24180R	24180RK30
	650	250	6	5 180	10 600	390	520	24180RHA	24180RHAK30
	720	256	6	5 210	9 850	350	470	23280R	23280RK

[Remark] Standard cage types used for the above bearings are shown in Table 5 earlier in this section.

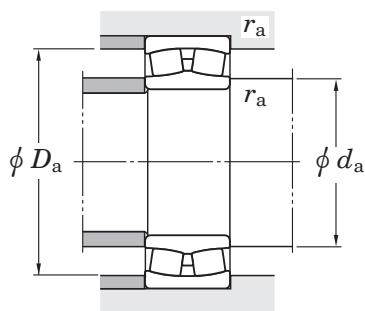

	Mounting dimensions (mm)			Con- stant <i>e</i>	Axial load factors			(Refer.) Mass (kg)	
	<i>d</i> _a min.	<i>D</i> _a max.	<i>r</i> _a max.		<i>Y</i> ₁	<i>Y</i> ₂	<i>Y</i> ₀	Cylindrical bore	Tapered bore
	382	578	4	0.33	2.07	3.09	2.03	228	221
	382	578	4	0.31	2.19	3.25	2.14	213	206
	382	578	4	0.39	1.74	2.59	1.70	287	283
	382	578	4	0.40	1.69	2.51	1.65	274	270
	388	622	5	0.27	2.47	3.68	2.42	248	243
	388	622	5	0.37	1.83	2.72	1.79	346	336
	388	622	5	0.35	1.92	2.85	1.87	328	318
	398	502	3	0.19	3.62	5.39	3.54	70.0	67.9
	402	538	4	0.24	2.79	4.16	2.73	122	118
	402	538	4	0.22	3.03	4.51	2.96	112	108
	402	538	4	0.30	2.26	3.36	2.21	156	154
	402	538	4	0.29	2.32	3.45	2.27	142	139
	402	598	4	0.31	2.18	3.24	2.13	240	233
	402	598	4	0.30	2.26	3.36	2.21	224	217
	402	598	4	0.38	1.78	2.65	1.74	302	297
	402	598	4	0.38	1.78	2.65	1.74	288	283
	408	652	5	0.36	1.85	2.76	1.81	386	375
	408	652	5	0.35	1.94	2.89	1.90	365	354
	418	522	3	0.18	3.76	5.59	3.67	73.0	70.7
	422	578	4	0.24	2.84	4.23	2.78	155	151
	422	578	4	0.23	2.94	4.37	2.87	142	138
	422	578	4	0.32	2.09	3.12	2.05	206	203
	422	578	4	0.31	2.21	3.29	2.16	192	189
	428	622	5	0.31	2.19	3.25	2.14	273	265
	428	622	5	0.29	2.30	3.43	2.25	255	247
	428	622	5	0.37	1.82	2.70	1.78	338	333
	428	622	5	0.37	1.82	2.71	1.78	322	317
	428	692	5	0.37	1.80	2.69	1.76	468	454

Spherical roller bearings

d (400) ~ (460) mm

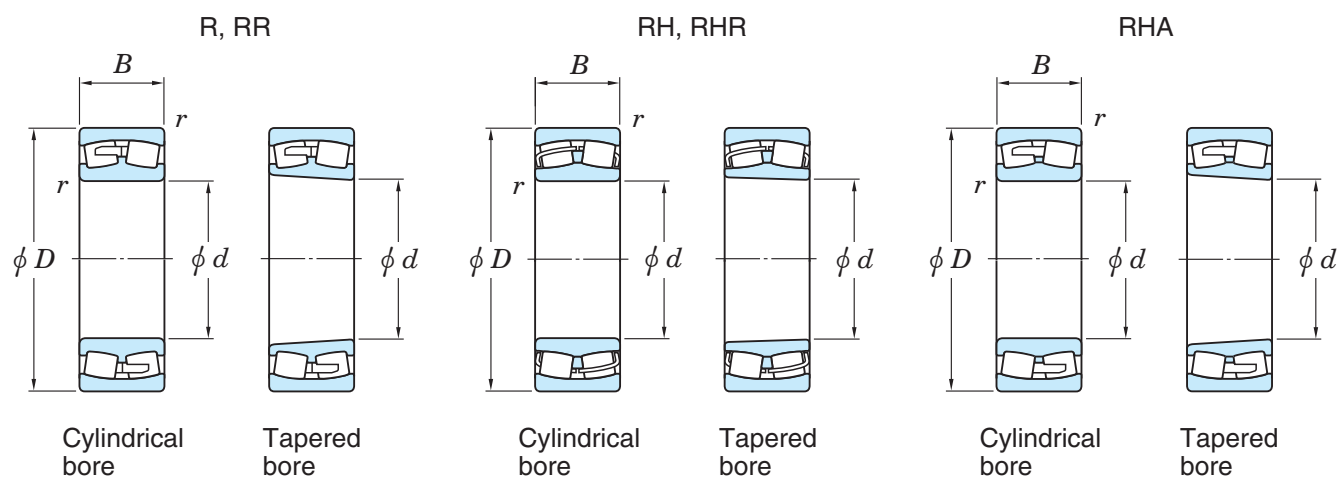

Boundary dimensions (mm)				Basic load ratings (kN)		Limiting speeds (min ⁻¹)		Bearing No.	
d	D	B	$r_{\min.}$	C_r	C_{0r}	Grease lub.	Oil lub.	Cylindrical bore	Tapered bore
400	720	256	6	5 850	10 600	350	460	23280RHA	23280RHAK
420	560	106	4	1 880	4 320	430	580	23984R	23984RK
	620	150	5	2 800	6 120	400	530	23084R	23084RK
	620	150	5	3 050	6 230	400	530	23084RHA	23084RHAK
	620	200	5	3 590	7 600	400	530	24084R	24084RK30
	620	200	5	3 870	8 490	400	530	24084RHA	24084RHAK30
	700	224	6	4 470	9 110	350	470	23184R	23184RK
	700	224	6	5 040	9 630	350	470	23184RHA	23184RHAK
	700	280	6	5 450	10 600	360	480	24184R	24184RK30
	700	280	6	6 120	12 400	350	470	24184RHA	24184RHAK30
	760	272	7.5	6 500	11 500	320	430	23284R	23284RK
760	272	7.5	6 580	11 900	320	430	23284RHA	23284RHAK	
440	600	118	4	2 330	5 330	400	530	23988R	23988RK
	650	157	6	3 030	6 540	370	500	23088R	23088RK
	650	157	6	3 370	6 910	370	490	23088RHA	23088RHAK
	650	212	6	3 910	8 320	370	490	24088R	24088RK30
	650	212	6	4 330	9 560	370	490	24088RHA	24088RHAK30
	720	226	6	5 040	9 600	330	440	23188R	23188RK
	720	226	6	5 250	10 300	330	440	23188RHA	23188RHAK
	720	280	6	5 640	11 200	340	450	24188R	24188RK30
	720	280	6	6 200	12 900	330	440	24188RHA	24188RHAK30
	790	280	7.5	6 860	12 300	300	400	23288R	23288RK
790	280	7.5	6 930	12 700	300	390	23288RHA	23288RHAK	
460	620	118	4	2 330	5 350	370	500	23992R	23992RK
	680	163	6	3 240	7 170	340	460	23092R	23092RK
	680	163	6	3 600	7 430	340	460	23092RHA	23092RHAK
	680	218	6	4 570	10 100	340	460	24092R	24092RK30

[Remark] Standard cage types used for the above bearings are shown in Table 5 earlier in this section.

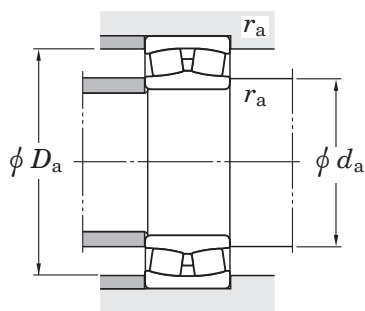

	Mounting dimensions (mm)			Con- stant e	Axial load factors			(Refer.) Mass (kg)	
	d_a min.	D_a max.	r_a max.		Y_1	Y_2	Y_0	Cylindrical bore	Tapered bore
	428	692	5	0.35	1.92	2.86	1.88	441	427
	438	542	3	0.17	3.91	5.82	3.82	76.0	73.6
	442	598	4	0.23	2.90	4.31	2.83	164	159
	442	598	4	0.22	3.02	4.49	2.95	150	145
	442	598	4	0.30	2.23	3.32	2.18	212	209
	442	598	4	0.29	2.31	3.44	2.26	198	195
	448	672	5	0.33	2.03	3.02	1.98	363	352
	448	672	5	0.31	2.19	3.25	2.14	339	328
	448	672	5	0.40	1.71	2.54	1.67	445	438
	448	672	5	0.39	1.72	2.56	1.68	425	418
	456	724	6	0.37	1.84	2.74	1.80	556	540
	456	724	6	0.36	1.90	2.83	1.86	525	508
	458	582	3	0.18	3.75	5.58	3.66	101	97.8
	468	622	5	0.24	2.76	4.11	2.70	188	183
	468	622	5	0.22	3.04	4.53	2.97	172	167
	468	622	5	0.29	2.35	3.50	2.30	247	243
	468	622	5	0.30	2.28	3.39	2.23	231	227
	468	692	5	0.33	2.08	3.09	2.03	378	366
	468	692	5	0.30	2.25	3.34	2.20	353	341
	468	692	5	0.38	1.76	2.62	1.72	460	453
	468	692	5	0.38	1.79	2.67	1.75	439	432
	476	754	6	0.36	1.86	2.77	1.82	613	595
	476	754	6	0.35	1.93	2.88	1.89	580	562
	478	602	3	0.17	3.89	5.79	3.80	107	104
	488	652	5	0.23	2.92	4.34	2.85	215	209
	488	652	5	0.22	3.04	4.53	2.97	197	191
	488	652	5	0.30	2.23	3.32	2.18	277	272

Spherical roller bearings

d (460) ~ 500 mm

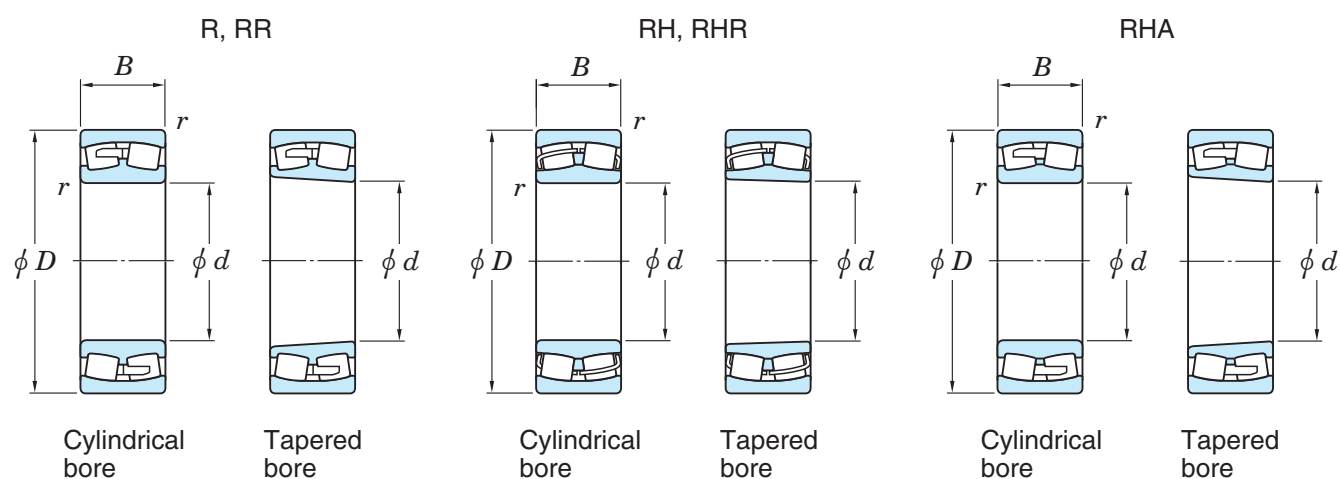

Boundary dimensions (mm)				Basic load ratings (kN)		Limiting speeds (min ⁻¹)		Bearing No.	
d	D	B	$r_{\min.}$	C_r	C_{0r}	Grease lub.	Oil lub.	Cylindrical bore	Tapered bore
460	680	218	6	4 640	10 300	340	460	24092RHA	24092RHAK30
	760	240	7.5	5 180	10 800	310	410	23192R	23192RK
	760	240	7.5	5 760	11 200	300	400	23192RHA	23192RHAK
	760	300	7.5	6 040	12 200	310	410	24192R	24192RK30
	760	300	7.5	6 920	14 200	310	410	24192RHA	24192RHAK30
	830	296	7.5	7 610	13 700	270	370	23292R	23292RK
	830	296	7.5	7 670	14 200	270	360	23292RHA	23292RHAK
480	650	128	5	2 630	6 130	350	460	23996R	23996RK
	700	165	6	3 350	7 540	320	430	23096R	23096RK
	700	165	6	3 730	7 860	320	430	23096RHA	23096RHAK
	700	218	6	4 420	9 650	320	430	24096R	24096RK30
	700	218	6	4 750	10 700	320	430	24096RHA	24096RHAK30
	790	248	7.5	5 440	11 500	280	380	23196R	23196RK
	790	248	7.5	6 160	12 000	280	380	23196RHA	23196RHAK
	790	308	7.5	7 190	14 800	280	380	24196R	24196RK30
	790	308	7.5	7 360	15 200	290	380	24196RHA	24196RHAK30
	870	310	7.5	8 380	15 100	250	340	23296R	23296RK
	870	310	7.5	8 450	15 700	250	340	23296RHA	23296RHAK
500	670	128	5	2 670	6 310	330	440	239/500R	239/500RK
	720	167	6	3 580	8 090	310	410	230/500R	230/500RK
	720	218	6	4 600	10 300	310	410	240/500R	240/500RK30
	830	264	7.5	6 160	13 000	260	350	231/500R	231/500RK
	830	325	7.5	7 710	15 900	260	350	241/500R	241/500RK30
	920	336	7.5	8 770	16 700	230	310	232/500R	232/500RK

[Remark] Standard cage types used for the above bearings are shown in Table 5 earlier in this section.

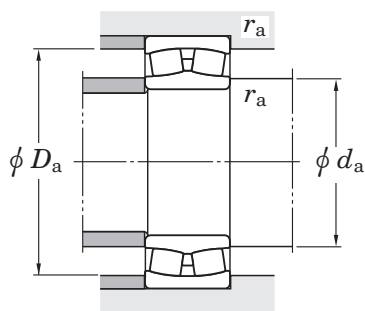

	Mounting dimensions (mm)			Constant e	Axial load factors			(Refer.) Mass (kg)	
	d_a min.	D_a max.	r_a max.		Y_1	Y_2	Y_0	Cylindrical bore	Tapered bore
	488	652	5	0.29	2.33	3.46	2.27	259	254
	496	724	6	0.33	2.07	3.09	2.03	450	436
	496	724	6	0.30	2.22	3.31	2.17	420	406
	496	724	6	0.35	1.95	2.90	1.91	550	541
	496	724	6	0.38	1.75	2.61	1.72	525	516
	496	794	6	0.36	1.85	2.76	1.81	720	699
	496	794	6	0.35	1.92	2.85	1.87	679	658
	502	628	4	0.18	3.75	5.59	3.67	123	119
	508	672	5	0.22	3.01	4.47	2.94	225	218
	508	672	5	0.22	3.12	4.64	3.05	206	199
	508	672	5	0.29	2.32	3.45	2.26	287	282
	508	672	5	0.28	2.41	3.59	2.35	268	263
	516	754	6	0.32	2.09	3.12	2.05	503	488
	516	754	6	0.30	2.24	3.34	2.19	470	455
	516	754	6	0.39	1.74	2.59	1.70	606	597
	516	754	6	0.38	1.78	2.65	1.74	580	568
	516	834	6	0.36	1.85	2.75	1.81	831	807
	516	834	6	0.35	1.91	2.85	1.87	785	761
	522	648	4	0.17	3.87	5.76	3.79	131	127
	528	692	5	0.23	2.94	4.37	2.87	235	228
	528	692	5	0.28	2.39	3.56	2.34	297	292
	536	794	6	0.33	2.05	3.05	2.00	595	577
	536	794	6	0.36	1.85	2.76	1.81	712	701
	536	884	6	0.39	1.74	2.59	1.70	1 020	992

Adapter assemblies for spherical roller bearings

d_1 20 ~ 65 mm

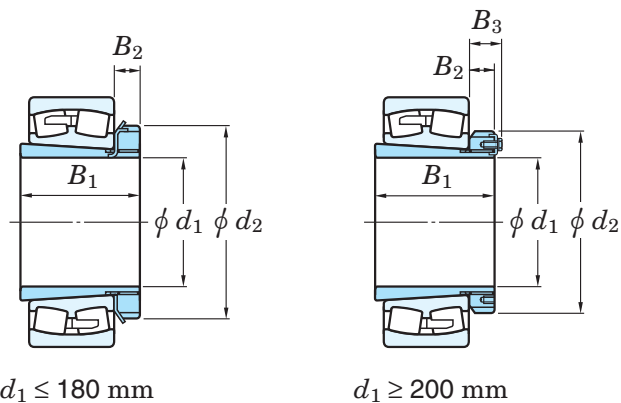

Boundary dimensions (mm)					Brg. bore d (mm)	Designations Bearing + adapter ass'y	Mounting dimensions (mm)				Mass Brg.+adapter ass'y (kg)	(Refer.)	
d_1	B_1	d_2	B_2	B_3			A min.	K min.	d_e min.	b min.		Adapter sleeve No.	Locknut No.
20	29	38	8	—	25	22205RHRK+H305X	15	45	29	5	0.269	A305X	AN05
25	31	45	8	—	30	22206RHRK+H306X	15	50	34	5	0.404	A306X	AN06
	31	45	8	—	30	21306RHK+H306X	15	50	34	6	0.538	A306X	AN06
30	35	52	9	—	35	22207RHRK+H307X	17	58	39	5	0.610	A307X	AN07
	35	52	9	—	35	21307RHK+H307X	17	58	39	7	0.725	A307X	AN07
35	36	58	10	—	40	22208RHRK+H308X	17	65	44	5	0.793	A308X	AN08
	36	58	10	—	40	21308RHK+H308X	17	65	44	5	0.972	A308X	AN08
	46	58	10	—	40	22308RHRK+H2308X	17	65	45	5	1.30	A2308X	AN08
40	39	65	11	—	45	22209RHRK+H309X	17	72	49	8	0.855	A309X	AN09
	39	65	11	—	45	21309RHK+H309X	17	72	49	5	1.31	A309X	AN09
	50	65	11	—	45	22309RHRK+H2309X	17	72	50	5	1.70	A2309X	AN09
45	42	70	12	—	50	22210RHRK+H310X	19	76	54	10	0.953	A310X	AN10
	42	70	12	—	50	21310RHK+H310X	19	76	54	5	1.67	A310X	AN10
	55	70	12	—	50	22310RHRK+H2310X	19	76	56	5	2.26	A2310X	AN10
50	45	75	12	—	55	22211RHRK+H311X	19	85	60	11	1.22	A311X	AN11
	45	75	12	—	55	21311RHK+H311X	19	85	60	6	2.04	A311X	AN11
	59	75	12	—	55	22311RHRK+H2311X	19	85	61	6	2.80	A2311X	AN11
55	47	80	13	—	60	22212RHRK+H312X	20	90	65	9	1.59	A312X	AN12
	47	80	13	—	60	21312RHK+H312X	20	90	65	5	2.50	A312X	AN12
	62	80	13	—	60	22312RHRK+H2312X	20	90	66	5	3.50	A2312X	AN12
60	50	85	14	—	65	22213RHRK+H313X	21	96	70	8	2.01	A313X	AN13
	50	85	14	—	65	21313RHK+H313X	21	96	70	5	3.07	A313X	AN13
	65	85	14	—	65	22313RHRK+H2313X	21	96	72	5	4.17	A2313X	AN13
65	55	98	15	—	75	22215RHRK+H315X	23	110	80	12	2.58	A315X	AN15
	55	98	15	—	75	21315RHK+H315X	23	110	80	5	4.65	A315X	AN15
	73	98	15	—	75	22315RHRK+H2315X	23	110	82	5	6.44	A2315X	AN15

d_1 70 ~ 110 mm

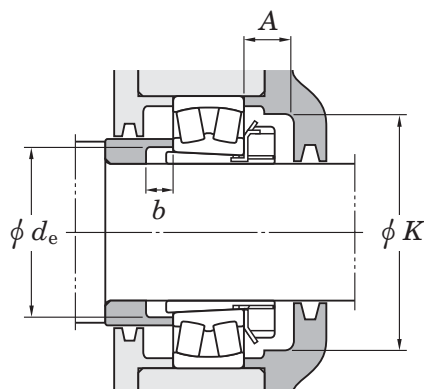

Boundary dimensions (mm)					Brg. bore d (mm)	Designations Bearing + adapter ass'y	Mounting dimensions (mm)				Mass Brg.+adapter ass'y (kg)	(Refer.)	
d_1	B_1	d_2	B_2	B_3			A min.	K min.	d_e min.	b min.		Adapter sleeve No.	Locknut No.
70	59	105	17	—	80	22216RHRK+H316X	25	120	86	12	3.22	A316X	AN16
	59	105	17	—	80	21316RHK+H316X	25	120	86	5	5.56	A316X	AN16
	78	105	17	—	80	22316RHRK+H2316X	25	120	87	5	7.64	A2316X	AN16
75	63	110	18	—	85	22217RHRK+H317X	27	128	91	12	3.93	A317X	AN17
	63	110	18	—	85	21317RHK+H317X	27	128	91	6	6.49	A317X	AN17
	82	110	18	—	85	22317RHRK+H2317X	27	128	94	6	8.83	A2317X	AN17
80	65	120	18	—	90	22218RHRK+H318X	28	139	96	10	4.88	A318X	AN18
	86	120	18	—	90	23218RHK+H2318X	28	139	99	18	6.20	A2318X	AN18
	65	120	18	—	90	21318RHK+H318X	28	139	96	6	7.56	A318X	AN18
	86	120	18	—	90	22318RHRK+H2318X	28	139	99	6	10.3	A2318X	AN18
85	68	125	19	—	95	22219RHRK+H319X	29	145	102	9	5.77	A319X	AN19
	68	125	19	—	95	21319RHK+H319X	29	145	102	7	8.68	A319X	AN19
	90	125	19	—	95	22319RHRK+H2319X	29	145	105	7	12.0	A2319X	AN19
90	71	130	20	—	100	22220RHRK+H320X	30	150	107	8	6.80	A320X	AN20
	97	130	20	—	100	23220RHK+H2320X	30	150	110	19	8.94	A2320X	AN20
	71	130	20	—	100	21320RHK+H320X	30	150	107	7	10.5	A320X	AN20
	97	130	20	—	100	22320RHRK+H2320X	30	150	110	7	15.2	A2320X	AN20
100	81	145	21	—	110	23122RHK+H3122X	32	170	117	7	7.91	A3122X	AN22
	77	145	21	—	110	22222RHRK+H322X	32	170	117	6	9.50	A322X	AN22
	105	145	21	—	110	23222RHK+H2322X	32	170	121	17	12.4	A2322X	AN22
	77	145	21	—	110	21322RHK+H322X	32	170	117	9	14.0	A322X	AN22
	105	145	21	—	110	22322RHRK+H2322X	32	170	121	7	20.6	A2322X	AN22
110	72	145	22	—	120	23024RHK+H3024X	33	180	127	7	6.12	A3024	ANL24
	88	155	22	—	120	23124RHK+H3124X	33	180	128	7	10.5	A3124	AN24
	88	155	22	—	120	22224RHRK+H3124X	33	180	128	11	11.9	A3124	AN24
	112	155	22	—	120	23224RHK+H2324X	33	180	131	17	15.1	A2324	AN24
	112	155	22	—	120	22324RHRK+H2324X	33	180	131	7	25.6	A2324	AN24

Adapter assemblies for spherical roller bearings

d_1 115 ~ (150) mm

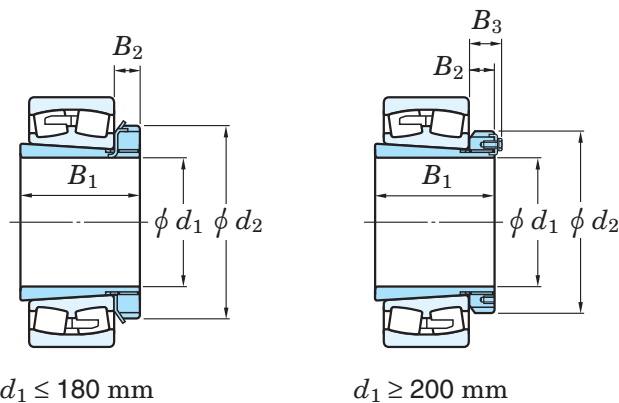

Boundary dimensions (mm)					Brg. bore d (mm)	Designations Bearing + adapter ass'y	Mounting dimensions (mm)				Mass Brg.+adapter ass'y (kg)	(Refer.)	
d_1	B_1	d_2	B_2	B_3			A min.	K min.	d_e min.	b min.		Adapter sleeve No.	Locknut No.
115	80	155	23	—	130	23026RHK+ H3026	34	190	137	8	9.01	A3026	ANL26
	92	165	23	—	130	23126RHK+ H3126	34	190	138	8	12.3	A3126	AN26
	92	165	23	—	130	22226RHRK+ H3126	34	190	138	8	15.1	A3126	AN26
	121	165	23	—	130	23226RHK+ H2326	34	190	142	21	18.8	A2326	AN26
	121	165	23	—	130	22326RHRK+ H2326	34	190	142	8	32.7	A2326	AN26
125	82	165	24	—	140	23028RHK+ H3028	36	205	147	8	9.79	A3028	ANL28
	97	180	24	—	140	23128RHK+ H3128	36	205	149	8	14.9	A3128	AN28
	97	180	24	—	140	22228RHRK+ H3128	36	205	149	8	18.8	A3128	AN28
	131	180	24	—	140	23228RHK+ H2328	36	205	152	22	24.3	A2328	AN28
	131	180	24	—	140	22328RHK+ H2328	36	205	152	8	40.8	A2328	AN28
135	87	180	26	—	150	23030RHK+ H3030	37	220	158	8	11.9	A3030	ANL30
	111	195	26	—	150	23130RHK+ H3130	37	220	160	8	21.7	A3130	AN30
	111	195	26	—	150	22230RHRK+ H3130	37	220	160	15	24.3	A3130	AN30
	139	195	26	—	150	23230RHK+ H2330	37	220	163	20	30.8	A2330	AN30
	139	195	26	—	150	22330RK+ H2330	37	220	163	8	49.7	A2330	AN30
	139	195	26	—	150	22330RHAK+ H2330	37	220	163	8	46.4	A2330	AN30
140	93	190	28	—	160	23032RHK+ H3032	39	230	168	8	15.0	A3032	ANL32
	119	210	28	—	160	23132RHK+ H3132	39	230	170	8	27.9	A3132	AN32
	119	210	28	—	160	22232RK+ H3132	39	230	170	14	30.6	A3132	AN32
	119	210	28	—	160	22232RHAK+ H3132	39	230	170	14	29.1	A3132	AN32
	147	210	28	—	160	23232RK+ H2332	39	230	174	18	39.6	A2332	AN32
	147	210	28	—	160	23232RHAK+ H2332	39	230	174	18	38.0	A2332	AN32
	147	210	28	—	160	22332RK+ H2332	39	230	174	8	60.5	A2332	AN32
	147	210	28	—	160	22332RHAK+ H2332	39	230	174	8	56.6	A2332	AN32
150	101	200	29	—	170	23034RHK+ H3034	40	250	179	8	19.2	A3034	ANL34
	122	220	29	—	170	23134RHK+ H3134	40	250	180	8	30.0	A3134	AN34
	122	220	29	—	170	22234RK+ H3134	40	250	180	10	37.2	A3134	AN34
	122	220	29	—	170	22234RHAK+ H3134	40	250	180	10	35.3	A3134	AN34

d_1 (150) ~ (180) mm

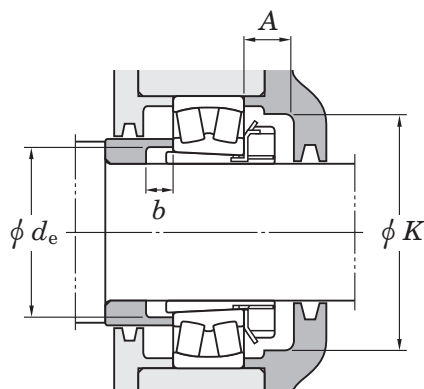

Boundary dimensions (mm)					Brg. bore d (mm)	Designations Bearing + adapter ass'y	Mounting dimensions (mm)				Mass Brg.+adapter ass'y (kg)	(Refer.)	
d_1	B_1	d_2	B_2	B_3			A min.	K min.	d_e min.	b min.		Adapter sleeve No.	Locknut No.
150	154	220	29	—	170	23234RK+H2334	40	250	185	18	47.2	A2334	AN34
	154	220	29	—	170	23234RHAK+H2334	40	250	185	18	45.3	A2334	AN34
	154	220	29	—	170	22334RK+H2334	40	250	185	8	71.5	A2334	AN34
	154	220	29	—	170	22334RHAK+H2334	40	250	185	8	66.8	A2334	AN34
160	109	210	30	—	180	23036RHK+H3036	41	260	189	8	24.2	A3036	ANL36
	131	230	30	—	180	23136RK+H3136	41	260	191	8	37.1	A3136	AN36
	131	230	30	—	180	23136RHAK+H3136	41	260	191	8	35.2	A3136	AN36
	131	230	30	—	180	22236RK+H3136	41	260	191	18	39.4	A3136	AN36
	131	230	30	—	180	22236RHAK+H3136	41	260	191	18	37.4	A3136	AN36
	161	230	30	—	180	23236RK+H2336	41	260	195	22	50.5	A2336	AN36
	161	230	30	—	180	23236RHAK+H2336	41	260	195	22	48.4	A2336	AN36
	161	230	30	—	180	22336RK+H2336	41	260	195	8	81.8	A2336	AN36
	161	230	30	—	180	22336RHAK+H2336	41	260	195	8	76.4	A2336	AN36
170	112	220	31	—	190	23038RK+H3038	43	270	199	9	26.1	A3038	ANL38
	112	220	31	—	190	23038RHAK+H3038	43	270	199	9	24.5	A3038	ANL38
	141	240	31	—	190	23138RK+H3138	43	270	202	9	45.3	A3138	AN38
	141	240	31	—	190	23138RHAK+H3138	43	270	202	9	43.0	A3138	AN38
	141	240	31	—	190	22238RK+H3138	43	270	202	21	47.5	A3138	AN38
	141	240	31	—	190	22238RHAK+H3138	43	270	202	21	45.0	A3138	AN38
	169	240	31	—	190	23238RK+H2338	43	270	206	21	59.2	A2338	AN38
	169	240	31	—	190	23238RHAK+H2338	43	270	206	21	56.7	A2338	AN38
	169	240	31	—	190	22338RK+H2338	43	270	206	9	95.6	A2338	AN38
169	240	31	—	190	22338RHAK+H2338	43	270	206	9	89.2	A2338	AN38	
180	120	240	32	—	200	23040RK+H3040	46	280	210	10	32.8	A3040	ANL40
	120	240	32	—	200	23040RHAK+H3040	46	280	210	10	30.7	A3040	ANL40
	150	250	32	—	200	23140RK+H3140	46	280	212	10	54.7	A3140	AN40
	150	250	32	—	200	23140RHAK+H3140	46	280	212	10	51.8	A3140	AN40
	150	250	32	—	200	22240RK+H3140	46	280	212	24	56.3	A3140	AN40
	150	250	32	—	200	22240RHAK+H3140	46	280	212	24	53.3	A3140	AN40

Adapter assemblies for spherical roller bearings

d_1 (180) ~ (240) mm

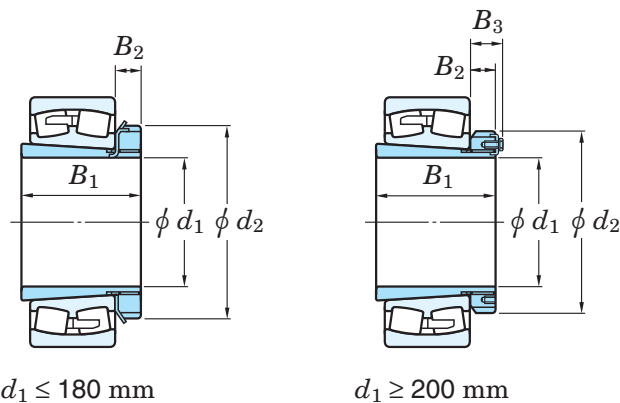

Boundary dimensions (mm)					Brg. bore d (mm)	Designations Bearing + adapter ass'y	Mounting dimensions (mm)				Mass Brg.+adapter ass'y (kg)	(Refer.)	
d_1	B_1	d_2	B_2	B_3			A min.	K min.	d_e min.	b min.		Adapter sleeve No.	Locknut No.
180	176	250	32	—	200	23240RK+H2340	46	280	216	20	71.0	A2340	AN40
	176	250	32	—	200	23240RHAK+H2340	46	280	216	20	68.0	A2340	AN40
	176	250	32	—	200	22340RK+H2340	46	280	216	10	108	A2340	AN40
	176	250	32	—	200	22340RHAK+H2340	46	280	216	10	101	A2340	AN40
200	128	260	30	41	220	23044RK+H3044	—	—	231	12	41.4	A3044	ANL44
	128	260	30	41	220	23044RHAK+H3044	—	—	231	12	38.7	A3044	ANL44
	158	280	32	44	220	23144RK+H3144	—	—	233	10	68.4	A3144	AN44
	158	280	32	44	220	23144RHAK+H3144	—	—	233	10	64.8	A3144	AN44
	158	280	32	44	220	22244RK+H3144	—	—	233	22	76.9	A3144	AN44
	158	280	32	44	220	22244RHAK+H3144	—	—	233	22	72.7	A3144	AN44
	183	280	32	44	220	23244RK+H2344	—	—	236	11	96.5	A2344	AN44
	183	280	32	44	220	23244RHAK+H2344	—	—	236	11	92.3	A2344	AN44
	183	280	32	44	220	22344RK+H2344	—	—	236	10	139	A2344	AN44
	183	280	32	44	220	22344RHAK+H2344	—	—	236	10	130	A2344	AN44
220	133	290	34	46	240	23048RK+H3048	—	—	251	11	47.7	A3048	ANL48
	133	290	34	46	240	23048RHAK+H3048	—	—	251	11	44.8	A3048	ANL48
	169	300	34	46	240	23148RK+H3148	—	—	254	11	83.6	A3148	AN48
	169	300	34	46	240	23148RHAK+H3148	—	—	254	11	79.1	A3148	AN48
	169	300	34	46	240	22248RK+H3148	—	—	254	19	101	A3148	AN48
	169	300	34	46	240	22248RHAK+H3148	—	—	254	19	95.6	A3148	AN48
	196	300	34	46	240	23248RK+H2348	—	—	257	6	128	A2348	AN48
	196	300	34	46	240	23248RHAK+H2348	—	—	257	6	122	A2348	AN48
	196	300	34	46	240	22348RK+H2348	—	—	257	11	175	A2348	AN48
	196	300	34	46	240	22348RHAK+H2348	—	—	257	11	163	A2348	AN48
240	147	310	34	46	260	23052RK+H3052	—	—	272	13	65.4	A3052	ANL52
	147	310	34	46	260	23052RHAK+H3052	—	—	272	13	61.0	A3052	ANL52
	187	330	36	49	260	23152RK+H3152	—	—	276	11	114	A3152	AN52
	187	330	36	49	260	23152RHAK+H3152	—	—	276	11	108	A3152	AN52

d_1 (240) ~ (300) mm

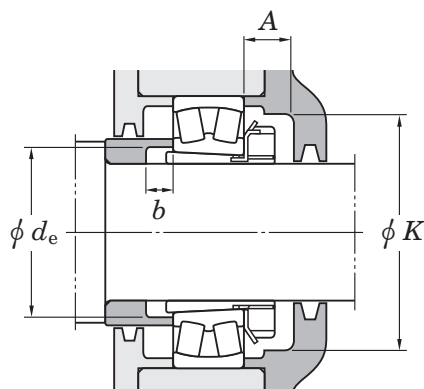

Boundary dimensions (mm)					Brg. bore d (mm)	Designations Bearing + adapter ass'y	Mounting dimensions (mm)				Mass Brg.+adapter ass'y (kg)	(Refer.)	
d_1	B_1	d_2	B_2	B_3			A min.	K min.	d_e min.	b min.		Adapter sleeve No.	Locknut No.
240	187	330	36	49	260	22252RK+H3152	—	—	276	25	131	A3152	AN52
	187	330	36	49	260	22252RHAK+H3152	—	—	276	25	124	A3152	AN52
	208	330	36	49	260	23252RK+H2352	—	—	278	2	165	A2352	AN52
	208	330	36	49	260	23252RHAK+H2352	—	—	278	2	158	A2352	AN52
	208	330	36	49	260	22352RK+H2352	—	—	278	11	217	A2352	AN52
	208	330	36	49	260	22352RHAK+H2352	—	—	278	11	202	A2352	AN52
260	152	330	38	50	280	23056RK+H3056	—	—	292	12	71.5	A3056	ANL56
	152	330	38	50	280	23056RHAK+H3056	—	—	292	12	66.8	A3056	ANL56
	192	350	38	51	280	23156RK+H3156	—	—	296	12	123	A3156	AN56
	192	350	38	51	280	23156RHAK+H3156	—	—	296	12	116	A3156	AN56
	192	350	38	51	280	22256RK+H3156	—	—	296	28	138	A3156	AN56
	192	350	38	51	280	22256RHAK+H3156	—	—	296	28	130	A3156	AN56
	221	350	38	51	280	23256RK+H2356	—	—	299	11	178	A2356	AN56
	221	350	38	51	280	23256RHAK+H2356	—	—	299	11	170	A2356	AN56
	221	350	38	51	280	22356RK+H2356	—	—	299	12	254	A2356	AN56
	221	350	38	51	280	22356RHAK+H2356	—	—	299	12	237	A2356	AN56
280	168	360	42	54	300	23060RK+H3060	—	—	313	12	97.7	A3060	ANL60
	168	360	42	54	300	23060RHAK+H3060	—	—	313	12	90.8	A3060	ANL60
	208	380	40	53	300	23160RK+H3160	—	—	317	12	159	A3160	AN60
	208	380	40	53	300	23160RHAK+H3160	—	—	317	12	150	A3160	AN60
	208	380	40	53	300	22260RK+H3160	—	—	317	32	173	A3160	AN60
	208	380	40	53	300	22260RHAK+H3160	—	—	317	32	163	A3160	AN60
	240	380	40	53	300	23260RK+H3260	—	—	321	12	227	A3260	AN60
	240	380	40	53	300	23260RHAK+H3260	—	—	321	12	217	A3260	AN60
300	171	380	42	55	320	23064RK+H3064	—	—	334	13	105	A3064	ANL64
	171	380	42	55	320	23064RHAK+H3064	—	—	334	13	98.1	A3064	ANL64
	226	400	42	56	320	23164RK+H3164	—	—	339	13	202	A3164	AN64
	226	400	42	56	320	23164RHAK+H3164	—	—	339	13	191	A3164	AN64
	226	400	42	56	320	22264RK+H3164	—	—	339	39	207	A3164	AN64

Adapter assemblies for spherical roller bearings

d_1 (300) ~ (400) mm

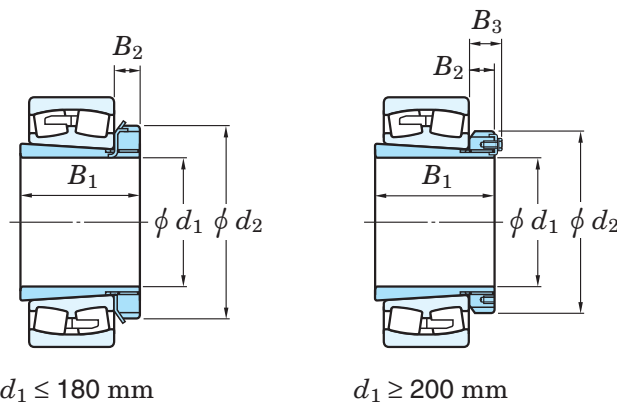

Boundary dimensions (mm)					Brg. bore d (mm)	Designations Bearing + adapter ass'y	Mounting dimensions (mm)				Mass Brg.+adapter ass'y (kg)	(Refer.)	
d_1	B_1	d_2	B_2	B_3			A min.	K min.	d_e min.	b min.		Adapter sleeve No.	Locknut No.
300	258	400	42	56	320	23264RK+H3264	—	—	343	13	283	A3264	AN64
	258	400	42	56	320	23264RHAK+H3264	—	—	343	13	270	A3264	AN64
320	187	400	45	58	340	23068RK+H3068	—	—	355	14	135	A3068	ANL68
	187	400	45	58	340	23068RHAK+H3068	—	—	355	14	126	A3068	ANL68
	254	440	55	72	340	23168RK+H3168	—	—	360	14	262	A3168	AN68
	254	440	55	72	340	23168RHAK+H3168	—	—	360	14	248	A3168	AN68
	288	440	55	72	340	23268RK+H3268	—	—	364	14	355	A3268	AN68
	288	440	55	72	340	23268RHAK+H3268	—	—	364	14	339	A3268	AN68
340	188	420	45	58	360	23072RK+H3072	—	—	375	14	143	A3072	ANL72
	188	420	45	58	360	23072RHAK+H3072	—	—	375	14	133	A3072	ANL72
	259	460	58	75	360	23172RK+H3172	—	—	380	14	278	A3172	AN72
	259	460	58	75	360	23172RHAK+H3172	—	—	380	14	263	A3172	AN72
	299	460	58	75	360	23272RK+H3272	—	—	385	14	400	A3272	AN72
	299	460	58	75	360	23272RHAK+H3272	—	—	385	14	382	A3272	AN72
360	193	450	48	62	380	23076RK+H3076	—	—	396	15	156	A3076	ANL76
	193	450	48	62	380	23076RHAK+H3076	—	—	396	15	146	A3076	ANL76
	264	490	60	77	380	23176RK+H3176	—	—	401	15	298	A3176	AN76
	264	490	60	77	380	23176RHAK+H3176	—	—	401	15	282	A3176	AN76
	310	490	60	77	380	23276RK+H3276	—	—	405	15	448	A3276	AN76
	310	490	60	77	380	23276RHAK+H3276	—	—	405	15	427	A3276	AN76
380	210	470	52	66	400	23080RK+H3080	—	—	417	15	195	A3080	ANL80
	210	470	52	66	400	23080RHAK+H3080	—	—	417	15	182	A3080	ANL80
	272	520	62	82	400	23180RK+H3180	—	—	421	15	339	A3180	AN80
	272	520	62	82	400	23180RHAK+H3180	—	—	421	15	321	A3180	AN80
	328	520	62	82	400	23280RK+H3280	—	—	427	15	539	A3280	AN80
	328	520	62	82	400	23280RHAK+H3280	—	—	427	15	512	A3280	AN80
400	212	490	52	66	420	23084RK+H3084	—	—	437	16	205	A3084	ANL84
	212	490	52	66	420	23084RHAK+H3084	—	—	437	16	191	A3084	ANL84

d_1 (400) ~ 470 mm

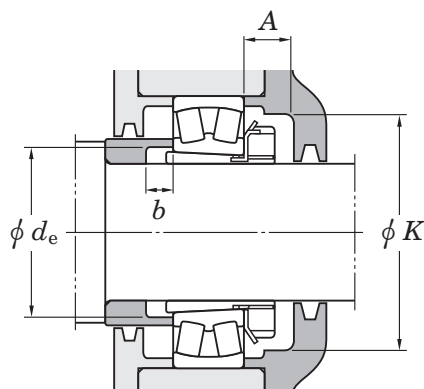

Boundary dimensions (mm)					Brg. bore d (mm)	Designations Bearing + adapter ass'y	Mounting dimensions (mm)				Mass Brg.+adapter ass'y (kg)	(Refer.)	
d_1	B_1	d_2	B_2	B_3			A min.	K min.	d_e min.	b min.		Adapter sleeve No.	Locknut No.
400	304	540	70	90	420	23184RK+ H3184	—	—	443	16	441	A3184	AN84
	304	540	70	90	420	23184RHA+ H3184	—	—	443	16	417	A3184	AN84
	352	540	70	90	420	23284RK+ H3284	—	—	448	16	639	A3284	AN84
	352	540	70	90	420	23284RHAK+ H3284	—	—	448	16	607	A3284	AN84
410	228	520	60	77	440	23088RK+ H3088	—	—	458	17	252	A3088	ANL88
	228	520	60	77	440	23088RHAK+ H3088	—	—	458	17	236	A3088	ANL88
	307	560	70	90	440	23188RK+ H3188	—	—	464	17	474	A3188	AN88
	307	560	70	90	440	23188RHAK+ H3188	—	—	464	17	449	A3188	AN88
	361	560	70	90	440	23288RK+ H3288	—	—	469	17	718	A3288	AN88
	361	560	70	90	440	23288RHAK+ H3288	—	—	469	17	685	A3288	AN88
430	234	540	60	77	460	23092RK+ H3092	—	—	478	17	283	A3092	ANL92
	234	540	60	77	460	23092RHAK+ H3092	—	—	478	17	265	A3092	ANL92
	326	580	75	95	460	23192RK+ H3192	—	—	485	17	559	A3192	AN92
	326	580	75	95	460	23192RHAK+ H3192	—	—	485	17	529	A3192	AN92
	382	580	75	95	460	23292RK+ H3292	—	—	491	17	838	A3292	AN92
	382	580	75	95	460	23292RHAK+ H3292	—	—	491	17	797	A3292	AN92
450	237	560	60	77	480	23096RK+ H3096	—	—	499	18	295	A3096	ANL96
	237	560	60	77	480	23096RHAK+ H3096	—	—	499	18	276	A3096	ANL96
	335	620	75	95	480	23196RK+ H3196	—	—	505	18	628	A3196	AN96
	335	620	75	95	480	23196RHAK+ H3196	—	—	505	18	595	A3196	AN96
	397	620	75	95	480	23296RK+ H3296	—	—	512	18	966	A3296	AN96
	397	620	75	95	480	23296RHAK+ H3296	—	—	512	18	920	A3296	AN96
470	247	580	68	85	500	230/500RK+ H30/500	—	—	519	18	315	A30/500	ANL100
	356	630	80	100	500	231/500RK+ H31/500	—	—	527	18	727	A31/500	AN100
	428	630	80	100	500	232/500RK+ H32/500	—	—	534	18	1 167	A32/500	AN100

Withdrawal sleeves for spherical roller bearings

d_1 35 ~ (75) mm

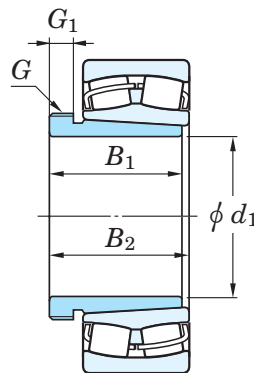

d_1	Boundary dimensions (mm)			G_1	Brg. bore d (mm)	Designations Bearing + withdrawal sleeve	Mass Brg.+withdrawal sleeve (kg)	(Refer.) Applicable locknut No.
	B_1	B_2	$G^{1)}$ Screw size					
35	29	32	M45×1.5	6	40	22208RHRK+AH308	0.681	AN09
	29	32	M45×1.5	6	40	21308RHK+AH308	0.860	AN09
	40	43	M45×1.5	7	40	22308RHRK+AH2308	1.19	AN09
40	31	34	M50×1.5	6	45	22209RHRK+AH309	0.699	AN10
	31	34	M50×1.5	6	45	21309RHK+AH309	1.14	AN10
	44	47	M50×1.5	7	45	22309RHRK+AH2309	1.55	AN10
45	35	38	M55×2	7	50	22210RHRK+AHX310	0.771	AN11
	35	38	M55×2	7	50	21310RHK+AHX310	1.49	AN11
	50	53	M55×2	9	50	22310RHRK+AHX2310	2.09	AN11
50	37	40	M60×2	7	55	22211RHRK+AHX311	1.01	AN12
	37	40	M60×2	7	55	21311RHK+AHX311	1.83	AN12
	54	57	M60×2	10	55	22311RHRK+AHX2311	2.60	AN12
55	40	43	M65×2	8	60	22212RHRK+AHX312	1.35	AN13
	40	43	M65×2	8	60	21312RHK+AHX312	2.27	AN13
	58	61	M65×2	11	60	22312RHRK+AHX2312	3.29	AN13
60	42	45	M75×2	8	65	22213RHRK+AH313	1.77	AN15
	42	45	M75×2	8	65	21313RHK+AH313	2.84	AN15
	61	64	M75×2	12	65	22313RHRK+AH2313	3.98	AN15
65	43	47	M80×2	8	70	22214RHRK+AH314	1.89	AN16
	43	47	M80×2	8	70	21314RHK+AH314	3.43	AN16
	64	68	M80×2	12	70	22314RHRK+AHX2314	4.82	AN16
70	45	49	M85×2	8	75	22215RHRK+AH315	2.01	AN17
	45	49	M85×2	8	75	21315RHK+AH315	4.07	AN17
	68	72	M85×2	12	75	22315RHRK+AHX2315	5.87	AN17
75	48	52	M90×2	8	80	22216RHRK+AH316	2.49	AN18
	48	52	M90×2	8	80	21316RHK+AH316	4.83	AN18

[Note] 1) Basic profile and dimensions of screw thread identified by prefix M are in accordance with JIS B 0205.
Basic profile and dimensions of screw thread identified by prefix Tr are in accordance with JIS B 0216.

d_1 (75) ~ (115) mm

d_1	Boundary dimensions (mm)				Brg. bore d (mm)	Designations Bearing + withdrawal sleeve	Mass Brg.+withdrawal sleeve (kg)	(Refer.) Applicable locknut No.
	B_1	B_2	$G^{1)}$ Screw size	G_1				
75	71	75	M90×2	12	80	22316RHRK+AHX2316	6.90	AN18
80	52	56	M95×2	9	85	22217RHRK+AHX317	3.12	AN19
	52	56	M95×2	9	85	21317RHK+AHX317	5.68	AN19
	74	78	M95×2	13	85	22317RHRK+AHX2317	7.98	AN19
85	53	57	M100×2	9	90	22218RHRK+AHX318	3.89	AN20
	63	67	M100×2	10	90	23218RHK+AHX3218	5.08	AN20
	53	57	M100×2	9	90	21318RHK+AHX318	6.58	AN20
	79	83	M100×2	14	90	22318RHRK+AHX2318	9.41	AN20
90	57	61	M105×2	10	95	22219RHRK+AHX319	4.68	AN21
	57	61	M105×2	10	95	21319RHK+AHX319	7.59	AN21
	85	89	M105×2	16	95	22319RHRK+AHX2319	10.9	AN21
95	59	63	M110×2	10	100	22220RHRK+AHX320	5.58	AN22
	73	77	M110×2	11	100	23220RHK+AHX3220	7.43	AN22
	59	63	M110×2	10	100	21320RHK+AHX320	9.26	AN22
	90	94	M110×2	16	100	22320RHRK+AHX2320	13.9	AN22
105	68	72	M120×2	11	110	23122RHK+AHX3122	6.30	AN24
	82	91	M115×2	13	110	24122RHK30+AH24122	7.60	AN23
	68	72	M120×2	11	110	22222RHRK+AHX3122	7.97	AN24
	82	86	M125×2	11	110	23222RHK+AHX3222	10.5	AN25
	63	67	M120×2	12	110	21322RHK+AHX322	12.3	AN24
	98	102	M125×2	16	110	22322RHRK+AHX2322	19.1	AN25
115	60	64	M130×2	13	120	23024RHK+AHX3024	4.82	AN26
	73	82	M125×2	13	120	24024RHK30+AH24024	5.99	AN25
	75	79	M130×2	12	120	23124RHK+AHX3124	8.69	AN26
	93	102	M130×2	13	120	24124RHK30+AH24124	11.0	AN26
	75	79	M130×2	12	120	22224RHRK+AHX3124	10.1	AN26

Withdrawal sleeves for spherical roller bearings

d_1 (115) ~ (150) mm

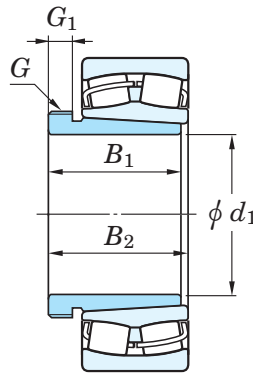

d_1	Boundary dimensions (mm)			G_1	Brg. bore d (mm)	Designations Bearing + withdrawal sleeve	Mass Brg.+withdrawal sleeve (kg)	(Refer.) Applicable locknut No.
	B_1	B_2	G^1 Screw size					
115	90	94	M135×2	13	120	23224RHK+ AHX3224	13.1	AN27
	105	109	M135×2	17	120	22324RHRK+ AHX2324	23.9	AN27
125	67	71	M140×2	14	130	23026RHK+ AHX3026	6.90	AN28
	83	93	M135×2	14	130	24026RHK30+ AH24026	8.74	AN27
	78	82	M140×2	12	130	23126RHK+ AHX3126	9.52	AN28
	94	104	M140×2	14	130	24126RHK30+ AH24126	11.7	AN28
	78	82	M140×2	12	130	22226RHRK+ AHX3126	12.4	AN28
	98	102	M145×2	15	130	23226RHK+ AHX3226	15.6	AN29
	115	119	M145×2	19	130	22326RHRK+ AHX2326	29.9	AN29
135	68	73	M150×2	14	140	23028RHK+ AHX3028	7.43	AN30
	83	93	M145×2	14	140	24028RHK30+ AH24028	9.26	AN29
	83	88	M150×2	14	140	23128RHK+ AHX3128	11.5	AN30
	99	109	M150×2	14	140	24128RHK30+ AH24128	14.1	AN30
	83	88	M150×2	14	140	22228RHRK+ AHX3128	15.4	AN30
	104	109	M155×3	15	140	23228RHK+ AHX3228	20.3	AN31
	125	130	M155×3	20	140	22328RHK+ AHX2328	35.0	AN31
145	72	77	M160×3	15	150	23030RHK+ AHX3030	8.92	AN32
	90	101	M155×3	15	150	24030RHK30+ AH24030	11.4	AN31
	96	101	M165×3	15	150	23130RHK+ AHX3130	17.7	AN33
	115	126	M160×3	15	150	24130RHK30+ AH24130	21.2	AN32
	96	101	M165×3	15	150	22230RHRK+ AHX3130	20.3	AN33
	114	119	M165×3	17	150	23230RHK+ AHX3230	26.0	AN33
	135	140	M165×3	24	150	22330RK+ AHX2330	45.5	AN33
	135	140	M165×3	24	150	22330RHAK+ AHX2330	42.2	AN33
150	77	82	M170×3	16	160	23032RHK+ AH3032	11.5	AN34
	95	106	M170×3	15	160	24032RHK30+ AH24032	15.0	AN34
	103	108	M180×3	16	160	23132RHK+ AH3132	23.4	AN36

[Note] 1) Basic profile and dimensions of screw thread identified by prefix M are in accordance with JIS B 0205.
Basic profile and dimensions of screw thread identified by prefix Tr are in accordance with JIS B 0216.

d_1 (150) ~ 170 mm

d_1	Boundary dimensions (mm)				Brg. bore d (mm)	Designations Bearing + withdrawal sleeve	Mass Brg.+withdrawal sleeve (kg)	(Refer.) Applicable locknut No.
	B_1	B_2	$G^{1)}$ Screw size	G_1				
150	103	108	M180×3	16	160	22232RK+AH3132	26.1	AN36
	103	108	M180×3	16	160	22232RHAK+AH3132	24.6	AN36
	124	130	M180×3	20	160	23232RK+AH3232	35.1	AN36
	124	130	M180×3	20	160	23232RHAK+AH3232	32.6	AN36
	140	146	M180×3	24	160	22332RK+AH2332	55.7	AN36
	140	146	M180×3	24	160	22332RHAK+AH2332	51.8	AN36
	160	85	90	M180×3	17	170	23034RHK+AH3034	15.2
106		117	M180×3	16	170	24034RHK30+AH24034	20.0	AN36
104		109	M190×3	16	170	23134RHK+AH3134	24.6	AN38
125		136	M180×3	16	170	24134RRK30+AH24134	30.0	AN36
104		109	M190×3	16	170	22234RK+AH3134	31.8	AN38
104		109	M190×3	16	170	22234RHAK+AH3134	29.9	AN38
134		140	M190×3	24	170	23234RK+AH3234	42.3	AN38
134		140	M190×3	24	170	23234RHAK+AH3234	39.4	AN38
146		152	M190×3	24	170	22334RK+AH2334	66.1	AN38
146		152	M190×3	24	170	22334RHAK+AH2334	61.4	AN38
170		92	98	M190×3	17	180	23036RHK+AH3036	19.7
	116	127	M190×3	16	180	24036RRK30+AH24036	26.1	AN38
	116	122	M200×3	19	180	23136RK+AH3136	31.7	AN40
	116	122	M200×3	19	180	23136RHAK+AH3136	29.8	AN40
	134	145	M190×3	16	180	24136RRK30+AH24136	37.6	AN38
	134	145	M190×3	16	180	24136RHAK30+AH24136	34.9	AN38
	105	110	M200×3	17	180	22236RK+AH2236	33.5	AN40
	105	110	M200×3	17	180	22236RHAK+AH2236	31.5	AN40
	140	146	M200×3	24	180	23236RK+AH3236	45.1	AN40
	140	146	M200×3	24	180	23236RHAK+AH3236	41.8	AN40
	154	160	M200×3	24	180	22336RK+AH2336	75.7	AN40
	154	160	M200×3	24	180	22336RHAK+AH2336	70.3	AN40

Withdrawal sleeves for spherical roller bearings

d_1 180 ~ 190 mm

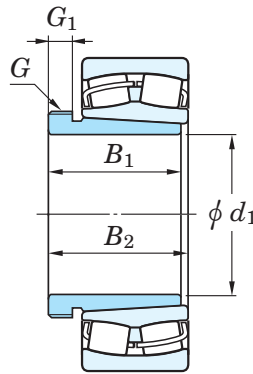

d_1	Boundary dimensions (mm)			G_1	Brg. bore d (mm)	Designations Bearing + withdrawal sleeve	Mass Brg.+withdrawal sleeve (kg)	(Refer.) Applicable locknut No.
	B_1	B_2	G^1 Screw size					
180	96	102	Tr205×4	18	190	23038RK+AH3038	21.5	HNL41
	96	102	Tr205×4	18	190	23038RHAK+AH3038	19.9	HNL41
	118	131	M200×3	18	190	24038RRK30+AH24038	27.6	AN40
	118	131	M200×3	18	190	24038RHAK30+AH24038	25.5	AN40
	125	131	Tr210×4	20	190	23138RK+AH3138	39.3	HN42
	125	131	Tr210×4	20	190	23138RHAK+AH3138	37.0	HN42
	146	159	M200×3	18	190	24138RRK30+AH24138	46.7	AN40
	146	159	M200×3	18	190	24138RHAK30+AH24138	43.8	AN40
	112	117	Tr210×4	18	190	22238RK+AH2238	40.9	HN42
	112	117	Tr210×4	18	190	22238RHAK+AH2238	38.4	HN42
	145	152	Tr210×4	25	190	23238RK+AH3238	53.3	HN42
	145	152	Tr210×4	25	190	23238RHAK+AH3238	49.4	HN42
	160	167	Tr210×4	26	190	22338RK+AH2338	89.0	HN42
	160	167	Tr210×4	26	190	22338RHAK+AH2338	82.6	HN42
190	102	108	Tr215×4	19	200	23040RK+AH3040	27.2	HNL43
	102	108	Tr215×4	19	200	23040RHAK+AH3040	25.1	HNL43
	127	140	Tr210×4	18	200	24040RRK30+AH24040	34.6	HN42
	127	140	Tr210×4	18	200	24040RHAK30+AH24040	31.9	HN42
	134	140	Tr220×4	21	200	23140RK+AH3140	47.9	HN44
	134	140	Tr220×4	21	200	23140RHAK+AH3140	45.0	HN44
	158	171	Tr210×4	18	200	24140RRK30+AH24140	57.6	HN42
	158	171	Tr210×4	18	200	24140RHAK30+AH24140	53.8	HN42
	118	123	Tr220×4	19	200	22240RK+AH2240	48.7	HN44
	118	123	Tr220×4	19	200	22240RHAK+AH2240	45.7	HN44
	153	160	Tr220×4	25	200	23240RK+AH3240	64.7	HN44
	153	160	Tr220×4	25	200	23240RHAK+AH3240	60.1	HN44
	170	177	Tr220×4	26	200	22340RK+AH2340	101	HN44
	170	177	Tr220×4	26	200	22340RHAK+AH2340	93.4	HN44

[Note] 1) Basic profile and dimensions of screw thread identified by prefix M are in accordance with JIS B 0205. Basic profile and dimensions of screw thread identified by prefix Tr are in accordance with JIS B 0216.

d_1 200 ~ 220 mm

d_1	Boundary dimensions (mm)				Brg. bore d (mm)	Designations Bearing + withdrawal sleeve	Mass Brg.+withdrawal sleeve (kg)	(Refer.) Applicable locknut No.
	B_1	B_2	$G^{1)}$ Screw size	G_1				
200	111	117	Tr235×4	20	220	23044RK+AH3044	38.0	HNL47
	111	117	Tr235×4	20	220	23044RHAK+AH3044	35.3	HNL47
	138	152	Tr230×4	20	220	24044RRK30+AH24044	48.1	—
	138	152	Tr230×4	20	220	24044RHAK30+AH24044	44.7	—
	145	151	Tr240×4	23	220	23144RK+AH3144	63.6	HN48
	145	151	Tr240×4	23	220	23144RHAK+AH3144	60.0	HN48
	170	184	Tr230×4	20	220	24144RRK30+AH24144	76.4	—
	170	184	Tr230×4	20	220	24144RHAK30+AH24144	71.2	—
	130	136	Tr240×4	20	220	22244RK+AH2244	70.8	HN48
	130	136	Tr240×4	20	220	22244RHAK+AH2244	66.6	HN48
	181	189	Tr240×4	30	220	23244RK+AH2344	95.1	HN48
	181	189	Tr240×4	30	220	23244RHAK+AH2344	88.5	HN48
	181	189	Tr240×4	30	220	22344RK+AH2344	136	HN48
	181	189	Tr240×4	30	220	22344RHAK+AH2344	127	HN48
	220	116	123	Tr260×4	21	240	23048RK+AH3048	42.6
116		123	Tr260×4	21	240	23048RHAK+AH3048	39.7	HNL52
138		153	Tr250×4	20	240	24048RRK30+AH24048	51.9	—
138		153	Tr250×4	20	240	24048RHAK30+AH24048	48.0	—
154		161	Tr260×4	25	240	23148RK+AH3148	77.6	HN52
154		161	Tr260×4	25	240	23148RHAK+AH3148	73.1	HN52
180		195	Tr260×4	20	240	24148RRK30+AH24148	94.0	HN52
180		195	Tr260×4	20	240	24148RHAK30+AH24148	87.9	HN52
144		150	Tr260×4	21	240	22248RK+AH2248	94.3	HN52
144		150	Tr260×4	21	240	22248RHAK+AH2248	88.7	HN52
189		197	Tr260×4	30	240	23248RK+AH2348	126	HN52
189		197	Tr260×4	30	240	23248RHAK+AH2348	117	HN52
189		197	Tr260×4	30	240	22348RK+AH2348	170	HN52
189		197	Tr260×4	30	240	22348RHAK+AH2348	158	HN52

Withdrawal sleeves for spherical roller bearings

d_1 240 ~ 260 mm

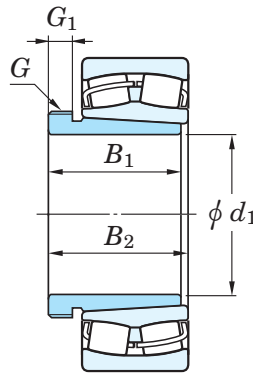

d_1	Boundary dimensions (mm)			G_1	Brg. bore d (mm)	Designations Bearing + withdrawal sleeve	Mass Brg.+withdrawal sleeve (kg)	(Refer.) Applicable locknut No.
	B_1	B_2	$G^{1)}$ Screw size					
240	128	135	Tr280×4	23	260	23052RK+AH3052	60.0	HNL56
	128	135	Tr280×4	23	260	23052RHAK+AH3052	55.6	HNL56
	162	178	Tr270×4	22	260	24052RRK30+AH24052	77.0	—
	162	178	Tr270×4	22	260	24052RHAK30+AH24052	71.2	—
	172	179	Tr290×4	26	260	23152RK+AH3152	107	HN58
	172	179	Tr290×4	26	260	23152RHAK+AH3152	101	HN58
	202	218	Tr280×4	22	260	24152RRK30+AH24152	128	—
	202	218	Tr280×4	22	260	24152RHAK30+AH24152	120	—
	155	161	Tr290×4	23	260	22252RK+AH2252	122	HN58
	155	161	Tr290×4	23	260	22252RHAK+AH2252	115	HN58
	205	213	Tr290×4	30	260	23252RK+AH2352	164	HN58
	205	213	Tr290×4	30	260	23252RHAK+AH2352	153	HN58
	205	213	Tr290×4	30	260	22352RK+AH2352	212	HN58
	205	213	Tr290×4	30	260	22352RHAK+AH2352	197	HN58
	260	131	139	Tr300×4	24	280	23056RK+AH3056	64.9
131		139	Tr300×4	24	280	23056RHAK+AH3056	60.2	HNL60
162		179	Tr290×4	22	280	24056RRK30+AH24056	81.9	HN58
162		179	Tr290×4	22	280	24056RHAK30+AH24056	75.7	HN58
175		183	Tr310×5	28	280	23156RK+AH3156	114	HN62
175		183	Tr310×5	28	280	23156RHAK+AH3156	108	HN62
202		219	Tr300×4	22	280	24156RRK30+AH24156	136	—
202		219	Tr300×4	22	280	24156RHAK30+AH24156	128	—
155		163	Tr310×5	24	280	22256RK+AH2256	127	HN62
155		163	Tr310×5	24	280	22256RHAK+AH2256	119	HN62
212		220	Tr310×5	30	280	23256RK+AH2356	175	HN62
212		220	Tr310×5	30	280	23256RHAK+AH2356	163	HN62
212		220	Tr310×5	30	280	22356RK+AH2356	247	HN62
212		220	Tr310×5	30	280	22356RHAK+AH2356	230	HN62

[Note] 1) Basic profile and dimensions of screw thread identified by prefix M are in accordance with JIS B 0205. Basic profile and dimensions of screw thread identified by prefix Tr are in accordance with JIS B 0216.

d_1 280 ~ (320) mm

d_1	Boundary dimensions (mm)				Brg. bore d (mm)	Designations Bearing + withdrawal sleeve	Mass Brg.+withdrawal sleeve (kg)	(Refer.) Applicable locknut No.
	B_1	B_2	$G^{1)}$ Screw size	G_1				
280	145	153	Tr320×5	26	300	23060RK+AH3060	88.1	HNL64
	145	153	Tr320×5	26	300	23060RHAK+AH3060	81.2	HNL64
	184	202	Tr310×5	24	300	24060RRK30+AH24060	112	HN62
	184	202	Tr310×5	24	300	24060RHAK30+AH24060	105	HN62
	192	200	Tr330×5	30	300	23160RK+AH3160	149	HN66
	192	200	Tr330×5	30	300	23160RHAK+AH3160	140	HN66
	224	242	Tr320×5	24	300	24160RRK30+AH24160	180	—
	224	242	Tr320×5	24	300	24160RHAK30+AH24160	168	—
	170	178	Tr330×5	26	300	22260RK+AH2260	160	HN66
	170	178	Tr330×5	26	300	22260RHAK+AH2260	150	HN66
	228	236	Tr330×5	34	300	23260RK+AH3260	223	HN66
	228	236	Tr330×5	34	300	23260RHAK+AH3260	208	HN66
	300	149	157	Tr345×5	27	320	23064RK+AH3064	94.8
149		157	Tr345×5	27	320	23064RHAK+AH3064	88.1	HNL69
184		202	Tr330×5	24	320	24064RRK30+AH24064	120	HN66
184		202	Tr330×5	24	320	24064RHAK30+AH24064	108	HN66
209		217	Tr350×5	31	320	23164RK+AH3164	191	HN70
209		217	Tr350×5	31	320	23164RHAK+AH3164	180	HN70
242		260	Tr340×5	24	320	24164RRK30+AH24164	226	—
242		260	Tr340×5	24	320	24164RHAK30+AH24164	217	—
180		190	Tr350×5	27	320	22264RK+AH2264	191	HN70
246		254	Tr350×5	36	320	23264RK+AH3264	280	HN70
246		254	Tr350×5	36	320	23264RHAK+AH3264	260	HN70
320	162	171	Tr365×5	28	340	23068RK+AH3068	125	HNL73
	162	171	Tr365×5	28	340	23068RHAK+AH3068	115	HNL73
	225	234	Tr370×5	33	340	23168RK+AH3168	239	HN74
	225	234	Tr370×5	33	340	23168RHAK+AH3168	225	HN74
	269	288	Tr360×5	26	340	24168RRK30+AH24168	293	—

Withdrawal sleeves for spherical roller bearings

d_1 (320) ~ 380 mm

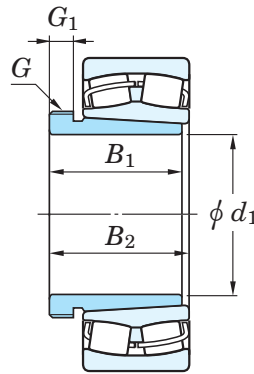

d_1	Boundary dimensions (mm)			G_1	Brg. bore d (mm)	Designations Bearing + withdrawal sleeve	Mass Brg.+withdrawal sleeve (kg)	(Refer.) Applicable locknut No.
	B_1	B_2	$G^{1)}$ Screw size					
320	269	288	Tr360×5	26	340	24168RHAK30+ AH24168	282	—
	264	273	Tr370×5	38	340	23268RK+ AH3268	342	HN74
	264	273	Tr370×5	38	340	23268RHAK+ AH3268	317	HN74
340	167	176	Tr385×5	30	360	23072RK+ AH3072	132	HNL77
	167	176	Tr385×5	30	360	23072RHAK+ AH3072	122	HNL77
	229	238	Tr400×5	35	360	23172RK+ AH3172	254	HN80
	232	238	Tr400×5	35	360	23172RHAK+ AH3172	239	HN80
	269	289	Tr380×5	26	360	24172RK30+ AH24172	313	—
	269	289	Tr380×5	26	360	24172RHAK30+ AH24172	300	—
	274	283	Tr400×5	40	360	23272RK+ AH3272	388	HN80
	274	283	Tr400×5	40	360	23272RHAK+ AH3272	360	HN80
360	170	180	Tr410×5	31	380	23076RK+ AH3076	141	HNL82
	170	180	Tr410×5	31	380	23076RHAK+ AH3076	131	HNL82
	232	242	Tr420×5	36	380	23176RK+ AH3176	269	HN84
	240	242	Tr420×5	36	380	23176RHAK+ AH3176	253	HN84
	271	291	Tr400×5	28	380	24176RK30+ AH24176	328	HN80
	271	291	Tr400×5	28	380	24176RHAK30+ AH24176	314	HN80
	284	294	Tr420×5	42	380	23276RK+ AH3276	432	HN84
	284	294	Tr420×5	42	380	23276RHAK+ AH3276	400	HN84
380	183	193	Tr430×5	33	400	23080RK+ AH3080	178	HNL86
	183	193	Tr430×5	33	400	23080RHAK+ AH3080	165	HNL86
	240	250	Tr440×5	38	400	23180RK+ AH3180	305	HN88
	266	250	Tr440×5	38	400	23180RHAK+ AH3180	287	HN88
	278	298	Tr420×5	28	400	24180RK30+ AH24180	368	HN84
	278	298	Tr420×5	28	400	24180RHAK30+ AH24180	352	HN84
	302	312	Tr440×5	44	400	23280RK+ AH3280	521	HN88
	302	312	Tr440×5	44	400	23280RHAK+ AH3280	480	HN88

[Note] 1) Basic profile and dimensions of screw thread identified by prefix M are in accordance with JIS B 0205.
Basic profile and dimensions of screw thread identified by prefix Tr are in accordance with JIS B 0216.

d_1 400 ~ 480 mm

d_1	Boundary dimensions (mm)				Brg. bore d (mm)	Designations Bearing + withdrawal sleeve	Mass Brg.+withdrawal sleeve (kg)	(Refer.) Applicable locknut No.
	B_1	B_2	$G^{1)}$ Screw size	G_1				
400	186	196	Tr450×5	34	420	23084RK+AH3084	188	HNL90
	186	196	Tr450×5	34	420	23084RHAK+AH3084	174	HNL90
	266	276	Tr460×5	40	420	23184RK+AH3184	399	HN92
	270	276	Tr460×5	40	420	23184RHAK+AH3184	375	HN92
	321	331	Tr460×5	46	420	23284RK+AH3284	673	HN92
	321	331	Tr460×5	46	420	23284RHAK+AH3284	568	HN92
420	194	205	Tr470×5	35	440	23088RK+AHX3088	215	HNL94
	194	205	Tr470×5	35	440	23088RHAK+AHX3088	199	HNL94
	270	281	Tr480×5	42	440	23188RK+AHX3188	416	HN96
	285	281	Tr480×5	42	440	23188RHAK+AHX3188	391	HN96
	330	341	Tr480×5	48	440	23288RK+AHX3288	678	HN96
	330	341	Tr480×5	48	440	23288RHAK+AHX3288	627	HN96
440	202	213	Tr490×5	37	460	23092RK+AHX3092	244	HNL98
	202	213	Tr490×5	37	460	23092RHAK+AHX3092	226	HNL98
	285	296	Tr510×6	43	460	23192RK+AHX3192	494	HN102
	295	296	Tr510×6	43	460	23192RHAK+AHX3192	464	HN102
	349	360	Tr510×6	50	460	23292RK+AHX3292	795	HN102
	349	360	Tr510×6	50	460	23292RHAK+AHX3292	733	HN102
460	205	217	Tr520×6	38	480	23096RK+AHX3096	257	HNL104
	205	217	Tr520×6	38	480	23096RHAK+AHX3096	238	HNL104
	295	307	Tr530×6	45	480	23196RK+AHX3196	551	HN106
	313	307	Tr530×6	45	480	23196RHAK+AHX3196	518	HN106
	364	376	Tr530×6	52	480	23296RK+AHX3296	914	HN106
	364	376	Tr530×6	52	480	23296RHAK+AHX3296	844	HN106
480	209	221	Tr540×6	40	500	230/500RK+AHX30/500	271	HNL108
	313	325	Tr550×6	47	500	231/500RK+AHX31/500	648	HN110
	393	405	Tr550×6	54	500	232/500RK+AHX32/500	1 015	HN110

KOYO



Thrust ball bearings

Thrust ball bearings are divided into single and double direction types. The former is able to accommodate axial load in one direction, while the latter is able to accommodate it in both directions.

Neither is suitable for applications that involve radial load or high-speed rotation.

Bearings whose housing race back face is spherical (with a spherical back face or aligning seat race) are designed with a self-aligning capability and can accommodate the effects of inaccurate mounting.

Single direction thrust ball bearings

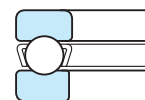

Bore diameter 10 – 360 mm

Double direction thrust ball bearings

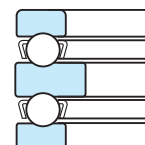

Bore diameter 10 – 190 mm

Boundary dimensions	As specified in JIS B 1512.																																																																																
Tolerances	As specified in JIS B 1514-2. (refer to Table 7-9 on p. A 68.)																																																																																
Recommended fits	Refer to Table 9-8 on p. A 92.																																																																																
Standard cages	<ul style="list-style-type: none"> ● Pressed steel cage (supplementary code : //) ● Copper alloy or carbon steel machined cage (supplementary code : FY or FC) ● Polyamide resin molded cage (supplementary code : MG) 																																																																																
Application of standard cages																																																																																	
	<table border="1"> <thead> <tr> <th>Bearing series</th> <th>Molded cage</th> <th>Pressed cage</th> <th>Machined cage</th> </tr> </thead> <tbody> <tr> <td>511</td> <td>51100 – 51107</td> <td>51108 – 51132</td> <td>51134 – 51172</td> </tr> <tr> <td>512</td> <td>51200 – 51207</td> <td>51208 – 51224</td> <td>51226 – 51272</td> </tr> <tr> <td>532</td> <td>53200 – 53207</td> <td>53208 – 53224</td> <td>53226 – 53272</td> </tr> <tr> <td>532 U</td> <td>53200U – 53207U</td> <td>53208U – 53224U</td> <td>53226U – 53272U</td> </tr> <tr> <td>513</td> <td>–</td> <td>51305 – 51313</td> <td>51314 – 51340</td> </tr> <tr> <td>533</td> <td>–</td> <td>53305 – 53313</td> <td>53314 – 53340</td> </tr> <tr> <td>533 U</td> <td>–</td> <td>53305U – 53313U</td> <td>53314U – 53340U</td> </tr> <tr> <td>514</td> <td>–</td> <td>51405 – 51416</td> <td>51417 – 51436</td> </tr> <tr> <td>534</td> <td>–</td> <td>53405 – 53416</td> <td>53417 – 53420</td> </tr> <tr> <td>534 U</td> <td>–</td> <td>53405U – 53416U</td> <td>53417U – 53420U</td> </tr> <tr> <td>522</td> <td>–</td> <td>52202 – 52224</td> <td>52226 – 52244</td> </tr> <tr> <td>542</td> <td>–</td> <td>54202 – 54224</td> <td>54226 – 54244</td> </tr> <tr> <td>542 U</td> <td>–</td> <td>54205U – 54224U</td> <td>54226U – 54244U</td> </tr> <tr> <td>523</td> <td>–</td> <td>52305 – 52313</td> <td>52314 – 52340</td> </tr> <tr> <td>543</td> <td>–</td> <td>54305 – 54313</td> <td>54314 – 54324</td> </tr> <tr> <td>543 U</td> <td>–</td> <td>54305U – 54313U</td> <td>54314U – 54324U</td> </tr> <tr> <td>524</td> <td>–</td> <td>52405 – 52411</td> <td>52412 – 52444</td> </tr> <tr> <td>544</td> <td>–</td> <td>54405 – 54411</td> <td>54412 – 54420</td> </tr> <tr> <td>544 U</td> <td>–</td> <td>54405U – 54411U</td> <td>54412U – 54420U</td> </tr> </tbody> </table>	Bearing series	Molded cage	Pressed cage	Machined cage	511	51100 – 51107	51108 – 51132	51134 – 51172	512	51200 – 51207	51208 – 51224	51226 – 51272	532	53200 – 53207	53208 – 53224	53226 – 53272	532 U	53200U – 53207U	53208U – 53224U	53226U – 53272U	513	–	51305 – 51313	51314 – 51340	533	–	53305 – 53313	53314 – 53340	533 U	–	53305U – 53313U	53314U – 53340U	514	–	51405 – 51416	51417 – 51436	534	–	53405 – 53416	53417 – 53420	534 U	–	53405U – 53416U	53417U – 53420U	522	–	52202 – 52224	52226 – 52244	542	–	54202 – 54224	54226 – 54244	542 U	–	54205U – 54224U	54226U – 54244U	523	–	52305 – 52313	52314 – 52340	543	–	54305 – 54313	54314 – 54324	543 U	–	54305U – 54313U	54314U – 54324U	524	–	52405 – 52411	52412 – 52444	544	–	54405 – 54411	54412 – 54420	544 U	–	54405U – 54411U	54412U – 54420U
Bearing series	Molded cage	Pressed cage	Machined cage																																																																														
511	51100 – 51107	51108 – 51132	51134 – 51172																																																																														
512	51200 – 51207	51208 – 51224	51226 – 51272																																																																														
532	53200 – 53207	53208 – 53224	53226 – 53272																																																																														
532 U	53200U – 53207U	53208U – 53224U	53226U – 53272U																																																																														
513	–	51305 – 51313	51314 – 51340																																																																														
533	–	53305 – 53313	53314 – 53340																																																																														
533 U	–	53305U – 53313U	53314U – 53340U																																																																														
514	–	51405 – 51416	51417 – 51436																																																																														
534	–	53405 – 53416	53417 – 53420																																																																														
534 U	–	53405U – 53416U	53417U – 53420U																																																																														
522	–	52202 – 52224	52226 – 52244																																																																														
542	–	54202 – 54224	54226 – 54244																																																																														
542 U	–	54205U – 54224U	54226U – 54244U																																																																														
523	–	52305 – 52313	52314 – 52340																																																																														
543	–	54305 – 54313	54314 – 54324																																																																														
543 U	–	54305U – 54313U	54314U – 54324U																																																																														
524	–	52405 – 52411	52412 – 52444																																																																														
544	–	54405 – 54411	54412 – 54420																																																																														
544 U	–	54405U – 54411U	54412U – 54420U																																																																														
Required minimum axial load	A certain degree of load is necessary in order for bearings to operate satisfactorily. (refer to p. A 110.)																																																																																
Allowable misalignment	Misalignment not allowed. (for flat back face type.)																																																																																
Equivalent axial load	Dynamic equivalent axial load $P_a = F_a$ Static equivalent axial load $P_{0a} = F_a$																																																																																

Single direction thrust ball bearings

d 10 ~ (40) mm

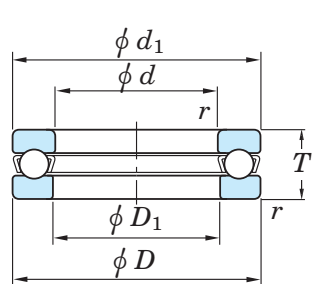

With flat back faces

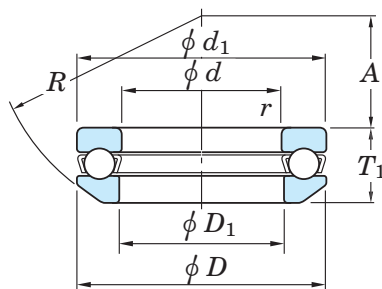

With spherical back face

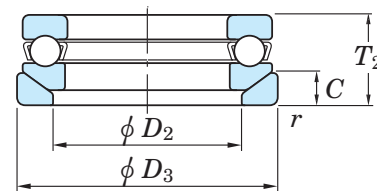

With aligning seat race

d	Boundary dimensions (mm)					Basic load ratings (kN)		Limiting speeds (min^{-1})		Bearing No.	
	D	T	T_1	T_2	$r_{\text{min.}}$	C_a	C_{0a}	Grease lub.	Oil lub.	With flat back faces	With spherical back face
10	24	9	—	—	0.3	10.0	14.0	6 500	10 000	51100	—
	26	11	11.6	13	0.6	12.7	17.1	5 700	8 800	51200	53200
12	26	9	—	—	0.3	9.65	14.0	6 500	10 000	51101	—
	28	11	11.4	13	0.6	13.2	19.0	5 400	8 300	51201	53201
15	28	9	—	—	0.3	9.95	15.4	6 100	9 400	51102	—
	32	12	13.3	15	0.6	16.6	24.8	4 900	7 500	51202	53202
17	30	9	—	—	0.3	10.8	18.2	6 100	9 400	51103	—
	35	12	13.2	15	0.6	17.2	27.3	4 900	7 500	51203	53203
20	35	10	—	—	0.3	14.2	24.7	5 100	7 900	51104	—
	40	14	14.7	17	0.6	22.3	37.7	3 900	6 000	51204	53204
25	42	11	—	—	0.6	19.5	37.2	4 400	6 800	51105	—
	47	15	16.7	19	0.6	27.8	50.4	3 600	5 500	51205	53205
	52	18	19.8	22	1	35.7	61.4	3 100	4 800	51305	53305
	60	24	26.4	29	1	55.6	89.4	2 600	4 000	51405	53405
30	47	11	—	—	0.6	20.4	42.2	4 300	6 600	51106	—
	52	16	17.8	20	0.6	29.4	58.2	3 400	5 200	51206	53206
	60	21	22.6	25	1	42.8	78.7	2 700	4 200	51306	53306
	70	28	30.1	33	1	72.8	126	2 200	3 400	51406	53406
35	52	12	—	—	0.6	21.2	47.2	3 900	6 000	51107	—
	62	18	19.9	22	1	39.2	78.2	2 900	4 500	51207	53207
	68	24	25.6	28	1	55.5	105	2 400	3 700	51307	53307
	80	32	34	37	1.1	87.1	155	1 900	2 900	51407	53407
40	60	13	—	—	0.6	26.9	62.8	3 400	5 300	51108	—
	68	19	20.3	23	1	47.0	98.3	2 700	4 200	51208	53208
	78	26	28.5	31	1	69.3	135	2 100	3 300	51308	53308

[Remark] Standard cage types used for the above bearings are described earlier in this section.

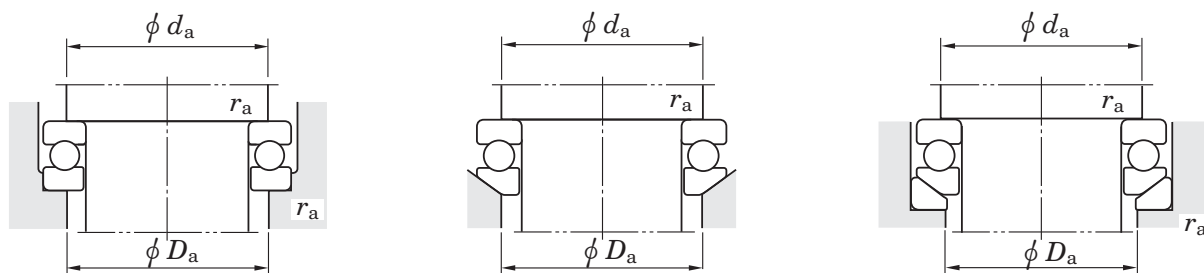

With aligning seat race	Dimensions (mm)							Mounting dimensions (mm)			(Refer.) Mass (kg)		
	d_1 max.	D_1 min.	D_2	D_3	A	R	C	d_a min.	D_a max.	r_a max.	With flat back faces	With spherical back face	With aligning seat race
— 53200U	24 26	11 12	— 18	— 28	— 8.5	— 22	— 3.5	18 20	16 16	0.3 0.6	0.020 0.030	— 0.029	— 0.037
— 53201U	26 28	13 14	— 20	— 30	— 11.5	— 25	— 3.5	20 22	18 18	0.3 0.6	0.022 0.034	— 0.031	— 0.043
— 53202U	28 32	16 17	— 24	— 35	— 12	— 28	— 4	23 25	20 22	0.3 0.6	0.024 0.046	— 0.048	— 0.062
— 53203U	30 35	18 19	— 26	— 38	— 16	— 32	— 4	25 28	22 24	0.3 0.6	0.028 0.053	— 0.055	— 0.070
— 53204U	35 40	21 22	— 30	— 42	— 18	— 36	— 5	29 32	26 28	0.3 0.6	0.040 0.082	— 0.080	— 0.100
— 53205U	42 47	26 27	— 36	— 50	— 19	— 40	— 5.5	35 38	32 34	0.6 0.6	0.059 0.120	— 0.120	— 0.152
53305U	52	27	38	55	21	45	6	41	36	1	0.180	0.180	0.224
53405U	60	27	42	62	19	50	8	46	39	1	0.340	0.350	0.442
— 53206U	47 52	32 32	— 42	— 55	— 22	— 45	— 5.5	40 43	37 39	0.6 0.6	0.068 0.150	— 0.160	— 0.193
53306U	60	32	45	62	22	50	7	48	42	1	0.270	0.270	0.326
53406U	70	32	50	75	20	56	9	54	46	1	0.530	0.530	0.660
— 53207U	52 62	37 37	— 48	— 65	— 24	— 50	— 7	45 51	42 46	0.6 1	0.090 0.220	— 0.220	— 0.277
53307U	68	37	52	72	24	56	7.5	55	48	1	0.390	0.400	0.484
53407U	80	37	58	85	23	64	10	62	53	1	0.790	0.790	0.960
— 53208U	60 68	42 42	— 55	— 72	— 28.5	— 56	— 7	52 57	48 51	0.6 1	0.120 0.270	— 0.270	— 0.340
53308U	78	42	60	82	28	64	8.5	63	55	1	0.550	0.570	0.690

Single direction thrust ball bearings

d (40) ~ 70 mm

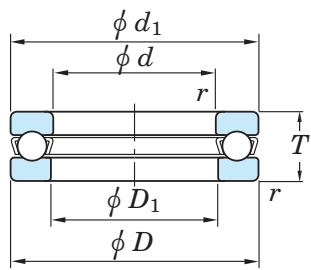

With flat back faces

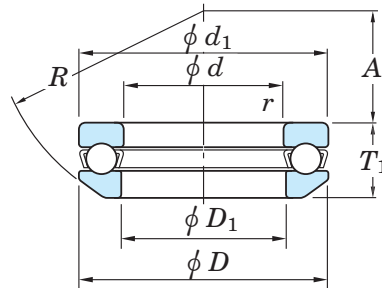

With spherical back face

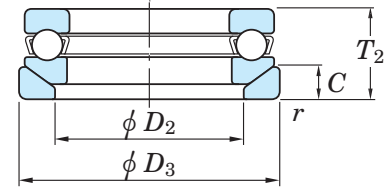

With aligning seat race

Boundary dimensions (mm)						Basic load ratings (kN)		Limiting speeds (min ⁻¹)		Bearing No.	
d	D	T	T_1	T_2	$r_{\min.}$	C_a	C_{0a}	Grease lub.	Oil lub.	With flat back faces	With spherical back face
40	90	36	38.2	42	1.1	113	205	1 700	2 600	51408	53408
45	65	14	—	—	0.6	27.8	69.1	3 200	5 000	51109	—
	73	20	21.3	24	1	47.7	105	2 600	4 000	51209	53209
	85	28	30.1	33	1	80.0	163	1 900	3 000	51309	53309
	100	39	42.4	46	1.1	130	242	1 500	2 300	51409	53409
50	70	14	—	—	0.6	28.8	75.4	3 100	4 800	51110	—
	78	22	23.5	26	1	48.5	111	2 300	3 600	51210	53210
	95	31	34.3	37	1.1	96.6	202	1 800	2 700	51310	53310
	110	43	45.6	50	1.5	148	283	1 400	2 100	51410	53410
55	78	16	—	—	0.6	34.8	93.1	2 800	4 300	51111	—
	90	25	27.3	30	1	69.4	159	2 100	3 200	51211	53211
	105	35	39.3	42	1.1	119	246	1 600	2 400	51311	53311
	120	48	50.5	55	1.5	178	359	1 200	1 900	51411	53411
60	85	17	—	—	1	41.4	113	2 600	4 000	51112	—
	95	26	28	31	1	73.6	179	1 900	3 000	51212	53212
	110	35	38.3	42	1.1	124	267	1 500	2 300	51312	53312
	130	51	54	58	1.5	214	437	1 100	1 700	51412	53412
65	90	18	—	—	1	41.7	117	2 400	3 700	51113	—
	100	27	28.7	32	1	74.9	189	1 900	2 900	51213	53213
	115	36	39.4	43	1.1	128	287	1 400	2 200	51313	53313
	140	56	60.2	65	2	232	493	1 000	1 600	51413	53413
70	95	18	—	—	1	43.1	127	2 300	3 600	51114	—
	105	27	28.8	32	1	76.1	199	1 800	2 800	51214	53214
	125	40	44.2	48	1.1	134	291	1 300	2 000	51314	53314
	150	60	63.6	69	2	250	553	940	1 450	51414	53414

[Remark] Standard cage types used for the above bearings are described earlier in this section.

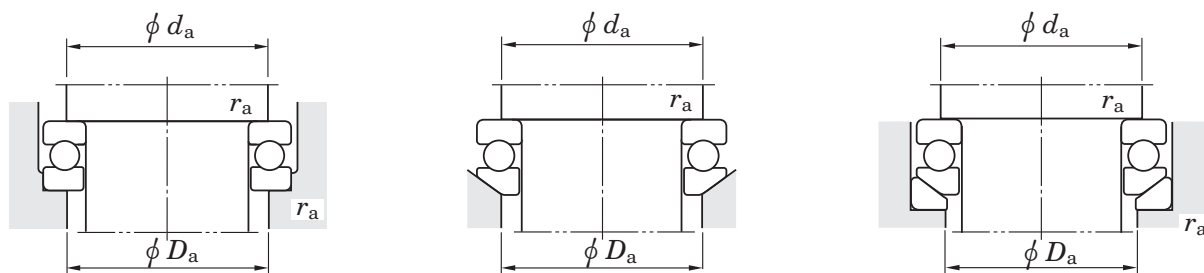

With aligning seat race	Dimensions (mm)							Mounting dimensions (mm)			(Refer.) Mass (kg)		
	d_1 max.	D_1 min.	D_2	D_3	A	R	C	d_a min.	D_a max.	r_a max.	With flat back faces	With spherical back face	With aligning seat race
53408U	90	42	65	95	26	72	12	70	60	1	1.14	1.12	1.37
—	65	47	—	—	—	—	—	57	53	0.6	0.150	—	—
53209U	73	47	60	78	26	56	7.5	62	56	1	0.320	0.310	0.397
53309U	85	47	65	90	25	64	10	69	61	1	0.690	0.680	0.850
53409U	100	47	72	105	29	80	12.5	78	67	1	1.47	1.50	1.82
—	70	52	—	—	—	—	—	62	58	0.6	0.160	—	—
53210U	78	52	62	82	32.5	64	7.5	67	61	1	0.390	0.380	0.480
53310U	95	52	72	100	28	72	11	77	68	1	1.00	1.01	1.24
53410U	110	52	80	115	35	90	14	86	74	1.5	1.99	1.97	2.38
—	78	57	—	—	—	—	—	69	64	0.6	0.240	—	—
53211U	90	57	72	95	35	72	9	76	69	1	0.610	0.620	0.770
53311U	105	57	80	110	30	80	11.5	85	75	1	1.34	1.41	1.69
53411U	120	57	88	125	28	90	15.5	94	81	1.5	2.64	2.57	3.10
—	85	62	—	—	—	—	—	75	70	1	0.290	—	—
53212U	95	62	78	100	32.5	72	9	81	74	1	0.690	0.690	0.850
53312U	110	62	85	115	41	90	11.5	90	80	1	1.43	1.47	1.78
53412U	130	62	95	135	34	100	16	102	88	1.5	3.51	3.44	4.13
—	90	67	—	—	—	—	—	80	75	1	0.340	—	—
53213U	100	67	82	105	40	80	9	86	79	1	0.770	0.750	0.930
53313U	115	67	90	120	38.5	90	12.5	95	85	1	1.57	1.61	1.95
53413U	140	68	100	145	40	112	17.5	110	95	2	4.47	4.47	5.28
—	95	72	—	—	—	—	—	85	80	1	0.360	—	—
53214U	105	72	88	110	38	80	9	91	84	1	0.810	0.800	0.990
53314U	125	72	98	130	43	100	13	103	92	1	2.06	2.15	2.56
53414U	150	73	110	155	34	112	19.5	118	102	2	5.48	5.38	6.37

Single direction thrust ball bearings

d 75 ~ (120) mm

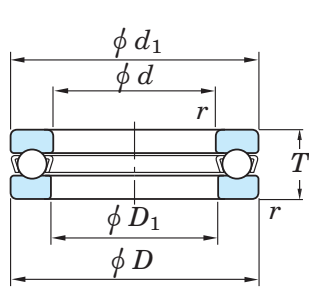

With flat back faces

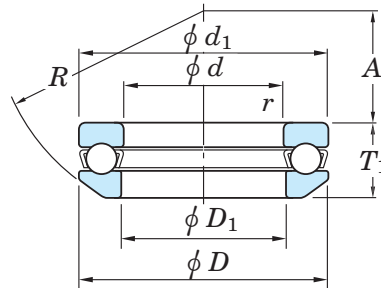

With spherical back face

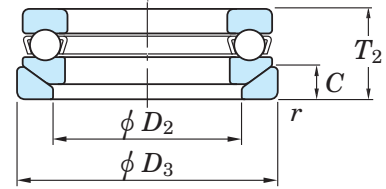

With aligning seat race

d	Boundary dimensions (mm)					Basic load ratings (kN)		Limiting speeds (min^{-1})		Bearing No.	
	D	T	T_1	T_2	$r_{\text{min.}}$	C_a	C_{0a}	Grease lub.	Oil lub.	With flat back faces	With spherical back face
75	100	19	—	—	1	44.4	136	2 200	3 400	51115	—
	110	27	28.3	32	1	77.4	209	1 800	2 700	51215	53215
	135	44	48.1	52	1.5	154	339	1 200	1 900	51315	53315
	160	65	69	75	2	252	560	880	1 350	51415	53415
80	105	19	—	—	1	44.7	141	2 100	3 300	51116	—
	115	28	29.5	33	1	78.5	218	1 700	2 600	51216	53216
	140	44	47.6	52	1.5	160	368	1 200	1 800	51316	53316
	170	68	72.2	78	2.1	270	621	810	1 250	51416	53416
85	110	19	—	—	1	45.9	150	2 100	3 200	51117	—
	125	31	33.1	37	1	95.4	264	1 500	2 300	51217	53217
	150	49	53.1	58	1.5	186	419	1 100	1 700	51317	53317
	180	72	77	83	2.1	307	753	780	1 200	51417	53417
90	120	22	—	—	1	59.7	190	1 900	2 900	51118	—
	135	35	38.5	42	1.1	117	326	1 400	2 100	51218	53218
	155	50	54.6	59	1.5	193	454	1 000	1 600	51318	53318
	190	77	81.2	88	2.1	327	826	710	1 100	51418	53418
100	135	25	—	—	1	85.0	268	1 600	2 500	51120	—
	150	38	40.9	45	1.1	146	410	1 200	1 900	51220	53220
	170	55	59.2	64	1.5	236	595	940	1 450	51320	53320
	210	85	90	98	3	368	983	620	950	51420	53420
110	145	25	—	—	1	87.0	288	1 600	2 400	51122	—
	160	38	40.2	45	1.1	152	450	1 200	1 800	51222	53222
	190	63	67.2	72	2	267	704	810	1 250	51322	53322
	230	95	—	—	3	379	1 070	550	850	51422	—
120	155	25	—	—	1	89.0	305	1 500	2 300	51124	—

[Remark] Standard cage types used for the above bearings are described earlier in this section.

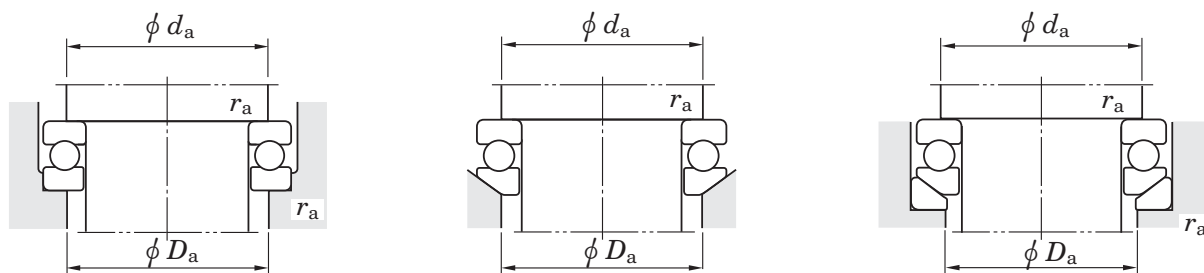

With aligning seat race	Dimensions (mm)							Mounting dimensions (mm)			(Refer.) Mass (kg)		
	d_1 max.	D_1 min.	D_2	D_3	A	R	C	d_a min.	D_a max.	r_a max.	With flat back faces	With spherical back face	With aligning seat race
—	100	77	—	—	—	—	—	90	85	1	0.420	—	—
53215U	110	77	92	115	49	90	9.5	96	89	1	0.860	0.850	1.06
53315U	135	77	105	140	37	100	15	111	99	1.5	2.68	2.72	3.27
53415U	160	78	115	165	42	125	21	125	110	2	6.75	6.64	7.87
—	105	82	—	—	—	—	—	95	90	1	0.430	—	—
53216U	115	82	98	120	46	90	10	101	94	1	0.950	0.930	1.15
53316U	140	82	110	145	50	112	15	116	104	1.5	2.82	2.86	3.43
53416U	170	83	125	175	36	125	22	133	117	2	7.97	7.84	9.22
—	110	87	—	—	—	—	—	100	95	1	0.460	—	—
53217U	125	88	105	130	52	100	11	109	101	1	1.29	1.28	1.57
53317U	150	88	115	155	43	112	17.5	124	111	1.5	3.66	3.63	4.44
53417U	177	88	130	185	47	140	23	141	124	2	9.29	9.20	10.8
—	120	92	—	—	—	—	—	108	102	1	0.680	—	—
53218U	135	93	110	140	45	100	13.5	117	108	1	1.77	1.77	2.19
53318U	155	93	120	160	40	112	18	129	116	1.5	3.88	3.87	4.71
53418U	187	93	140	195	40	140	25.5	149	131	2	11.0	10.7	12.6
—	135	102	—	—	—	—	—	121	114	1	0.990	—	—
53220U	150	103	125	155	52	112	14	130	120	1	2.36	2.34	2.84
53320U	170	103	135	175	46	125	18	142	128	1.5	5.11	5.10	6.05
53420U	205	103	155	220	50	160	27	165	145	2.5	14.6	14.5	17.4
—	145	112	—	—	—	—	—	131	124	1	1.08	—	—
53222U	160	113	135	165	65	125	14	140	130	1	2.57	2.50	3.06
53322U	187	113	150	195	51	140	20.5	158	142	2	7.72	7.63	8.90
—	225	113	—	—	—	—	—	181	159	2.5	19.8	—	—
—	155	122	—	—	—	—	—	141	134	1	1.16	—	—

Single direction thrust ball bearings

d (120) ~ (180) mm

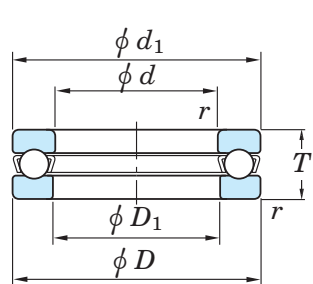

With flat back faces

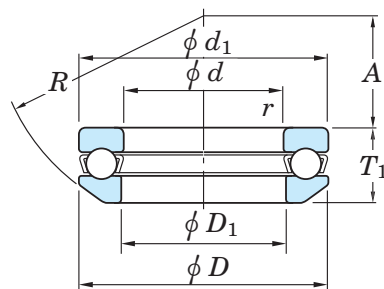

With spherical back face

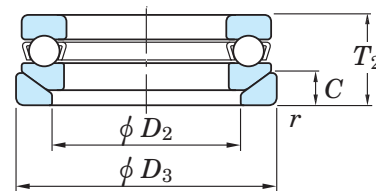

With aligning seat race

d	Boundary dimensions (mm)					Basic load ratings (kN)		Limiting speeds (min^{-1})		Bearing No.	
	D	T	T_1	T_2	$r_{\text{min.}}$	C_a	C_{0a}	Grease lub.	Oil lub.	With flat back faces	With spherical back face
120	170	39	40.8	46	1.1	154	470	1 100	1 700	51224	53224
	210	70	74.1	80	2.1	311	869	710	1 100	51324	53324
	250	102	—	—	4	480	1 460	520	800	51424	—
130	170	30	—	—	1	104	350	1 300	2 000	51126	—
	190	45	47.9	53	1.5	203	620	970	1 500	51226	53226
	225	75	80.3	86	2.1	330	958	650	1 000	51326	53326
	270	110	—	—	4	498	1 540	490	750	51426	—
140	180	31	—	—	1	107	375	1 200	1 900	51128	—
	200	46	48.6	55	1.5	205	650	940	1 450	51228	53228
	240	80	84.9	92	2.1	365	1 130	620	950	51328	53328
	280	112	—	—	4	520	1 680	450	700	51428	—
150	190	31	—	—	1	109	400	1 200	1 900	51130	—
	215	50	53.3	60	1.5	213	652	840	1 300	51230	53230
	250	80	83.7	92	2.1	361	1 130	580	900	51330	53330
	300	120	—	—	4	568	1 910	420	650	51430	—
160	200	31	—	—	1	112	425	1 200	1 800	51132	—
	225	51	54.7	61	1.5	223	718	810	1 250	51232	53232
	270	87	91.7	100	3	410	1 340	550	850	51332	53332
	320	130	—	—	5	681	2 410	390	600	51432	—
170	215	34	—	—	1.1	134	510	1 100	1 700	51134	—
	240	55	58.7	65	1.5	261	834	750	1 150	51234	53234
	280	87	91.3	100	3	463	1 570	520	800	51334	53334
	340	135	—	—	5	755	2 730	360	550	51434	—
180	225	34	—	—	1.1	135	525	1 000	1 600	51136	—
	250	56	58.2	66	1.5	265	874	710	1 100	51236	53236
	300	95	99.3	109	3	463	1 580	490	750	51336	53336

[Remark] Standard cage types used for the above bearings are described earlier in this section.

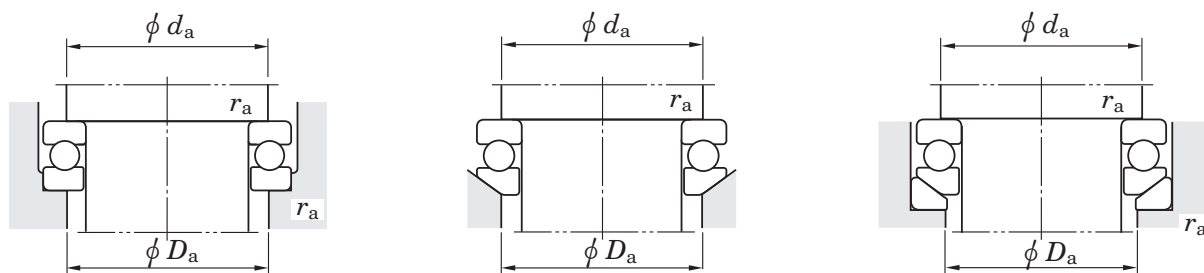

With aligning seat race	Dimensions (mm)							Mounting dimensions (mm)			(Refer.) Mass (kg)		
	d_1 max.	D_1 min.	D_2	D_3	A	R	C	d_a min.	D_a max.	r_a max.	With flat back faces	With spherical back face	With aligning seat race
53224U	170	123	145	175	61	125	15	150	140	1	2.86	2.81	3.46
53324U	205	123	165	220	63	160	22	173	157	2	10.6	10.4	12.4
—	245	123	—	—	—	—	—	196	174	3	25.0	—	—
—	170	132	—	—	—	—	—	154	146	1	1.87	—	—
53226U	187	133	160	195	67	140	17	166	154	1.5	4.09	3.98	4.88
53326U	220	134	177	235	53	160	26	186	169	2	13.0	12.7	15.2
—	265	134	—	—	—	—	—	212	188	3	31.4	—	—
—	178	142	—	—	—	—	—	164	156	1	2.02	—	—
53228U	197	143	170	210	87	160	17	176	164	1.5	4.46	4.35	5.89
53328U	235	144	190	250	68	180	26	199	181	2	15.5	15.1	18.0
—	275	144	—	—	—	—	—	222	198	3	33.9	—	—
—	188	152	—	—	—	—	—	174	166	1	2.15	—	—
53230U	212	153	180	225	79	160	20.5	189	176	1.5	5.64	5.45	7.14
53330U	245	154	200	260	89.5	200	26	209	191	2	16.3	15.7	18.8
—	295	154	—	—	—	—	—	238	212	3	41.6	—	—
—	198	162	—	—	—	—	—	184	176	1	2.28	—	—
53232U	222	163	190	235	74	160	21	199	186	1.5	6.53	6.09	7.90
53332U	265	164	215	280	77	200	29	225	205	2.5	21.0	21.0	23.4
—	315	164	—	—	—	—	—	254	226	4	51.2	—	—
—	213	172	—	—	—	—	—	197	188	1	3.25	—	—
53234U	237	173	200	250	91	180	21.5	212	198	1.5	8.12	7.69	9.83
53334U	275	174	220	290	105	225	29	235	215	2.5	22.0	22.0	24.5
—	335	174	—	—	—	—	—	270	240	4	60.0	—	—
—	222	183	—	—	—	—	—	207	198	1	3.39	—	—
53236U	247	183	210	260	112	200	21.5	222	208	1.5	8.68	8.08	10.4
53336U	295	184	240	310	91	225	32	251	229	2.5	28.1	26.9	29.9

Single direction thrust ball bearings

d (180) ~ 360 mm

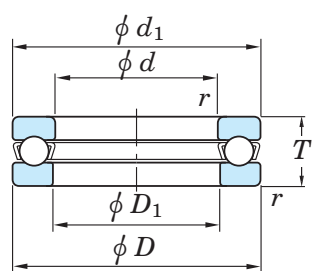

With flat back faces

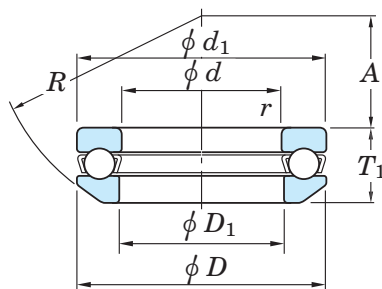

With spherical back face

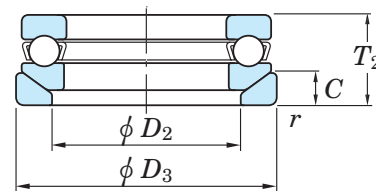

With aligning seat race

Boundary dimensions (mm)						Basic load ratings (kN)		Limiting speeds (min ⁻¹)		Bearing No.	
d	D	T	T_1	T_2	$r_{\text{min.}}$	C_a	C_{0a}	Grease lub.	Oil lub.	With flat back faces	With spherical back face
180	360	140	—	—	5	742	2 730	320	500	51436	—
190	240	37	—	—	1.1	170	655	970	1 500	51138	—
	270	62	65.7	73	2	308	1 060	650	1 000	51238	53238
	320	105	111	121	4	543	1 950	440	680	51338	53338
200	250	37	—	—	1.1	172	675	940	1 450	51140	—
	280	62	65.3	74	2	314	1 110	620	950	51240	53240
	340	110	118.4	130	4	596	2 220	420	650	51340	53340
220	270	37	—	—	1.1	177	740	880	1 350	51144	—
	300	63	65.6	75	2	342	1 310	580	900	51244	53244
240	300	45	—	—	1.5	241	1 020	750	1 150	51148	—
	340	78	81.6	92	2.1	442	1 800	520	800	51248	53248
260	320	45	—	—	1.5	231	990	710	1 100	51152	—
	360	79	82.8	93	2.1	445	1 880	490	750	51252	53252
280	350	53	—	—	1.5	329	1 430	640	900	51156	—
300	380	62	—	—	2	363	1 610	540	810	51160	—
	420	95	100.5	112	3	570	2 600	400	600	51260	53260
320	400	63	—	—	2	379	1 760	540	810	51164	—
	440	95	100.5	112	3	577	2 710	400	600	51264	53264
340	420	64	—	—	2	387	1 860	500	770	51168	—
	460	96	100.3	113	3	584	2 830	380	570	51268	53268
360	440	65	—	—	2	394	1 960	500	720	51172	—
	500	110	116.7	130	4	701	3 500	340	500	51272	53272

[Remark] Standard cage types used for the above bearings are described earlier in this section.

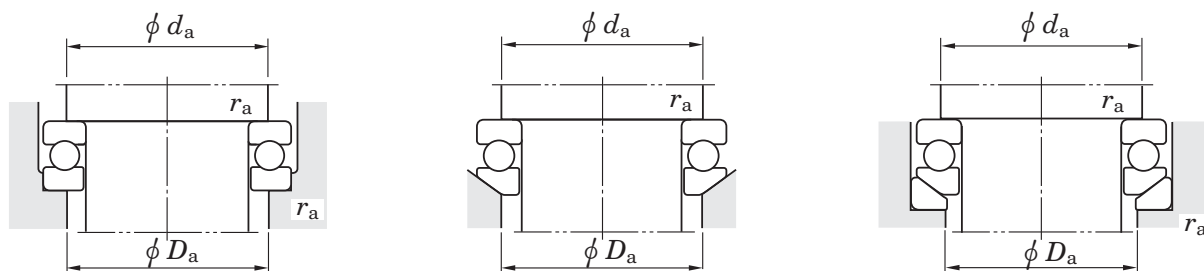

With aligning seat race	Dimensions (mm)							Mounting dimensions (mm)			(Refer.) Mass (kg)		
	d_1 max.	D_1 min.	D_2	D_3	A	R	C	d_a min.	D_a max.	r_a max.	With flat back faces	With spherical back face	With aligning seat race
—	355	184	—	—	—	—	—	286	254	4	69.5	—	—
—	237	193	—	—	—	—	—	220	210	1	3.95	—	—
53238U	267	194	230	280	98	200	23	238	222	2	11.7	11.2	13.9
53338U	315	195	255	330	104	250	33	266	244	3	36.0	36.3	39.7
—	247	203	—	—	—	—	—	230	220	1	4.13	—	—
53240U	277	204	240	290	125	225	23	248	232	2	12.2	11.6	14.8
53340U	335	205	270	350	92	250	38	282	258	3	42.9	42.7	46.7
—	267	223	—	—	—	—	—	250	240	1	4.50	—	—
53244U	297	224	260	310	118	225	25	268	252	2	13.5	12.6	15.9
—	297	243	—	—	—	—	—	276	264	1.5	7.38	—	—
53248U	335	244	290	350	122	250	30	299	281	2	23.1	20.9	25.6
—	317	263	—	—	—	—	—	296	284	1.5	7.93	—	—
53252U	355	264	305	370	152	280	30	319	301	2	25.0	22.6	28.5
—	347	283	—	—	—	—	—	322	308	1.5	12.0	—	—
—	376	304	—	—	—	—	—	348	332	2	17.5	—	—
53260U	415	304	360	430	164	320	34	371	349	2.5	42.5	39.5	48.0
—	396	324	—	—	—	—	—	368	352	2	19.0	—	—
53264U	435	325	380	450	157	320	36	391	369	2.5	45.0	42.0	52.0
—	416	344	—	—	—	—	—	388	372	2	20.5	—	—
53268U	455	345	400	470	199	360	36	411	389	2.5	48.0	45.0	55.0
—	436	364	—	—	—	—	—	408	392	2	21.5	—	—
53272U	495	365	430	510	172	360	43	443	417	3	70.0	65.0	82.0

Double direction thrust ball bearings

d_2 10 ~ (50) mm

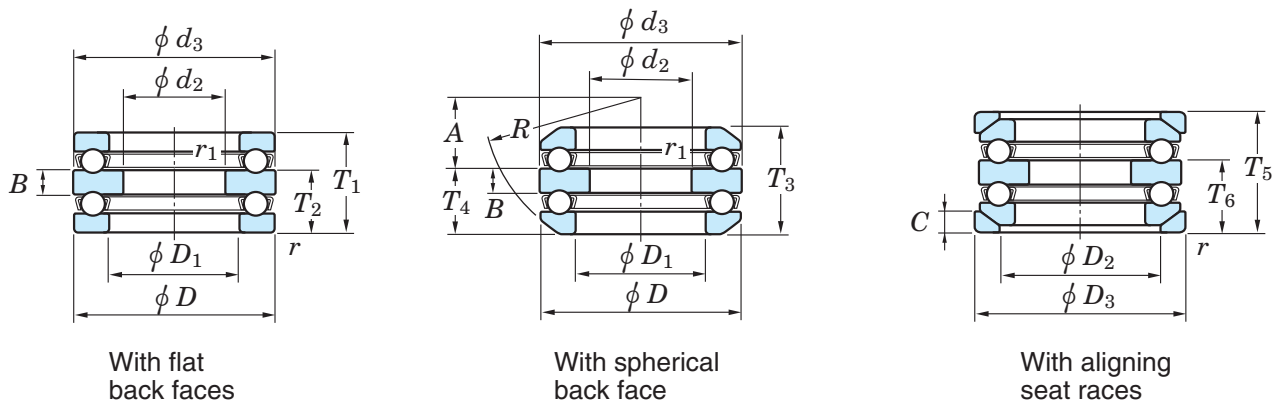

d_2	Boundary dimensions (mm)						Basic load ratings (kN)		Limiting speeds (min^{-1})		Bearing No.		
	D	T_1	T_3	T_5	$r_{\text{min.}}$	$r_1_{\text{min.}}$	C_a	C_{0a}	Grease lub.	Oil lub.	With flat back faces	With spherical back faces	With aligning seat races
10	32	22	24.6	28	0.6	0.3	16.6	24.8	4 900	7 500	52202	54202	54202U
15	40	26	27.4	32	0.6	0.3	22.3	37.7	3 900	6 000	52204	54204	54204U
	60	45	49.8	55	1	0.6	55.6	89.4	2 600	4 000	52405	54405	54405U
20	47	28	31.4	36	0.6	0.3	27.7	50.4	3 600	5 500	52205	54205	54205U
	52	34	37.6	42	1	0.3	35.7	61.4	3 100	4 800	52305	54305	54305U
	70	52	56.2	62	1	0.6	72.8	126	2 200	3 400	52406	54406	54406U
25	52	29	32.6	37	0.6	0.3	28.1	54.3	3 400	5 200	52206	54206	54206U
	60	38	41.2	46	1	0.3	42.8	78.7	2 700	4 200	52306	54306	54306U
	80	59	63	69	1.1	0.6	87.1	155	1 900	2 900	52407	54407	54407U
30	62	34	37.8	42	1	0.3	40.7	83.8	2 900	4 500	52207	54207	54207U
	68	36	38.6	44	1	0.6	46.9	98.3	2 700	4 200	52208	54208	54208U
	68	44	47.2	52	1	0.3	55.5	105	2 400	3 700	52307	54307	54307U
	78	49	54	59	1	0.6	69.3	135	2 100	3 300	52308	54308	54308U
	90	65	69.4	77	1.1	0.6	113	205	1 700	2 600	52408	54408	54408U
35	73	37	39.6	45	1	0.6	47.7	105	2 600	4 000	52209	54209	54209U
	85	52	56.2	62	1	0.6	80.0	163	1 900	3 000	52309	54309	54309U
	100	72	78.8	86	1.1	0.6	130	242	1 500	2 300	52409	54409	54409U
40	78	39	42	47	1	0.6	48.5	111	2 300	3 600	52210	54210	54210U
	95	58	64.6	70	1.1	0.6	91.6	186	1 800	2 700	52310	54310	54310U
	110	78	83.2	92	1.5	0.6	148	283	1 400	2 100	52410	54410	54410U
45	90	45	49.6	55	1	0.6	69.4	159	2 100	3 200	52211	54211	54211U
	105	64	72.6	78	1.1	0.6	119	246	1 600	2 400	52311	54311	54311U
	120	87	92	101	1.5	0.6	178	359	1 200	1 900	52411	54411	54411U
50	95	46	50	56	1	0.6	73.6	179	1 900	3 000	52212	54212	54212U
	110	64	70.6	78	1.1	0.6	124	267	1 500	2 300	52312	54312	54312U
	130	93	99	107	1.5	0.6	201	397	1 100	1 700	52412	54412	54412U

[Remark] Standard cage types used for the above bearings are described earlier in this section.

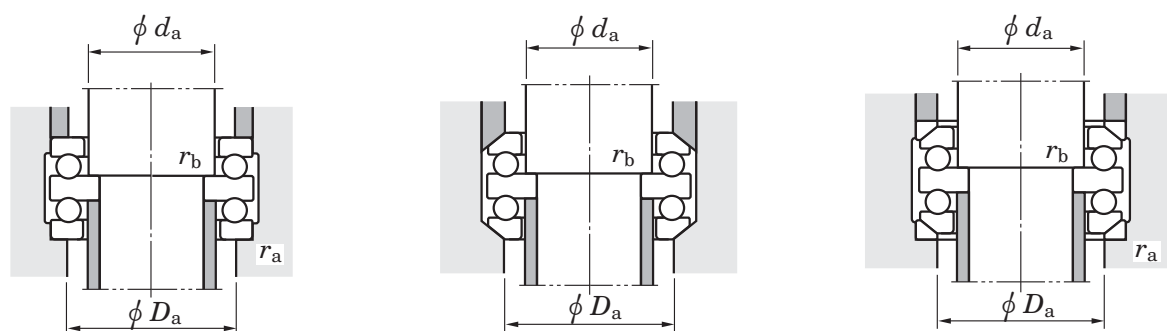

	Dimensions (mm)											Mounting dimensions (mm)				(Refer.) Mass (kg)	
	d_3 max.	D_1 min.	D_2	D_3	T_2	T_4	T_6	A	R	B	C	d_a min.	D_a max.	r_a max.	r_b max.	With flat back faces	With aligning seat races
	32	17	24	35	13.5	14.8	16.5	10.5	28	5	4	15	24	0.6	0.3	0.085	0.118
	40	22	30	42	16	16.7	19	16	36	6	5	20	30	0.6	0.3	0.150	0.190
	60	27	42	62	28	30.4	33	15	50	11	8	25	42	1	0.6	0.630	0.804
	47	27	36	50	17.5	19.2	21.5	16.5	40	7	5.5	25	36	0.6	0.3	0.230	0.304
	52	27	38	55	21	22.8	25	18	45	8	6	25	38	1	0.3	0.330	0.428
	70	32	50	75	32	34.1	37	16	56	12	9	30	50	1	0.6	1.00	1.25
	52	32	42	55	18	19.8	22	20	45	7	5.5	30	42	0.6	0.3	0.270	0.346
	60	32	45	62	23.5	25.1	27.5	19.5	50	9	7	30	45	1	0.3	0.490	0.602
	80	37	58	85	36.5	38.5	41.5	18.5	64	14	10	35	58	1	0.6	1.44	1.79
	62	37	48	65	21	22.9	25	21	50	8	7	35	48	1	0.3	0.420	0.544
	68	42	55	72	22.5	23.8	26.5	25	56	9	7	40	55	1	0.6	0.540	0.680
	68	37	52	72	27	28.6	31	21	56	10	7.5	35	52	1	0.3	0.710	0.898
	78	42	60	82	30.5	33	35.5	23.5	64	12	8.5	40	60	1	0.6	1.06	1.34
	90	42	65	95	40	42.2	46	22	72	15	12	40	65	1	0.6	2.03	2.55
	73	47	60	78	23	24.3	27	23	56	9	7.5	45	60	1	0.6	0.620	0.784
	85	47	65	90	32	34.1	37	21	64	12	10	45	65	1	0.6	1.29	1.62
	100	47	72	105	44.5	47.9	51.5	23.5	80	17	12.5	45	72	1	0.6	2.91	3.42
	78	52	62	82	24	25.5	28	30.5	64	9	7.5	50	62	1	0.6	0.710	0.890
	95	52	72	100	36	39.3	42	23	72	14	11	50	72	1	0.6	1.86	2.35
	110	52	80	115	48	50.6	55	30	90	18	14	50	80	1.5	0.6	3.56	4.39
	90	57	72	95	27.5	29.8	32.5	32.5	72	10	9	55	72	1	0.6	1.12	1.44
	105	57	80	110	39.5	43.8	46.5	25.5	80	15	11.5	55	80	1	0.6	2.51	3.21
	120	57	88	125	53.5	56	60.5	22.5	90	20	15.5	55	88	1.5	0.6	4.70	5.62
	95	62	78	100	28	30	33	30.5	72	10	9	60	78	1	0.6	1.25	1.57
	110	62	85	115	39.5	42.8	46.5	36.5	90	15	11.5	60	85	1	0.6	2.68	3.37
	130	62	95	135	57	60	64	28	100	21	16	60	95	1.5	0.6	6.33	7.60

Double direction thrust ball bearings

d_2 (50) ~ 95 mm

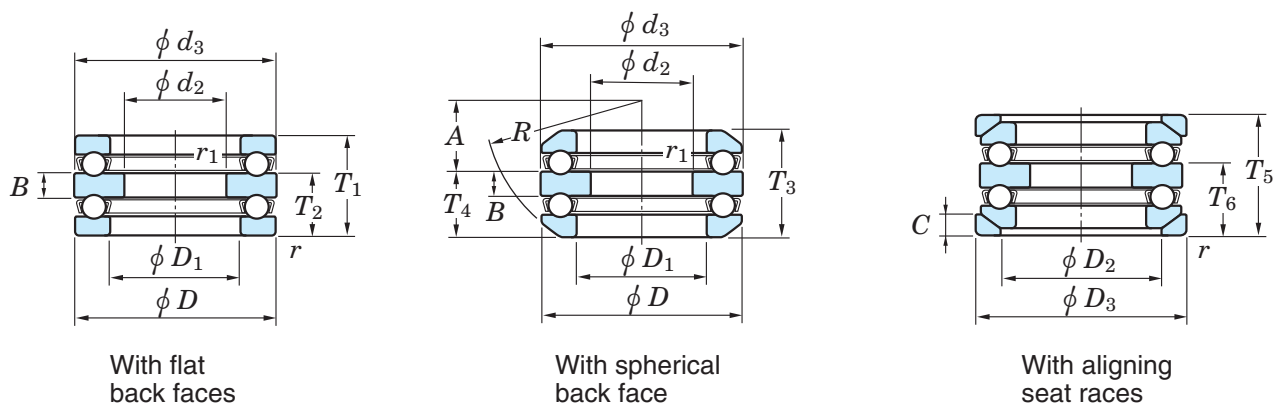

d_2	Boundary dimensions (mm)						Basic load ratings (kN)		Limiting speeds (min^{-1})		Bearing No.		
	D	T_1	T_3	T_5	r min.	r_1 min.	C_a	C_{0a}	Grease lub.	Oil lub.	With flat back faces	With spherical back faces	With aligning seat races
50	140	101	109.4	119	2	1	232	493	1 000	1 600	52413	54413	54413U
55	100	47	50.4	57	1	0.6	74.8	189	1 900	2 900	52213	54213	54213U
	105	47	50.6	57	1	1	73.6	189	1 800	2 800	52214	54214	54214U
	115	65	71.8	79	1.1	0.6	128	287	1 400	2 200	52313	54313	54313U
	125	72	80.4	88	1.1	1	148	339	1 300	2 000	52314	54314	54314U
	150	107	114.2	125	2	1	250	553	940	1 450	52414	54414	54414U
60	110	47	49.6	57	1	1	77.4	209	1 800	2 700	52215	54215	54215U
	135	79	87.2	95	1.5	1	171	396	1 200	1 900	52315	54315	54315U
	160	115	123	135	2	1	252	560	880	1 350	52415	54415	54415U
65	115	48	51	58	1	1	78.5	218	1 700	2 600	52216	54216	54216U
	140	79	86.2	95	1.5	1	176	424	1 200	1 800	52316	54316	54316U
	170	120	128.4	140	2.1	1	270	621	810	1 250	52416	54416	54416U
	180	128	138	150	2.1	1.1	307	753	780	1 200	52417	54417	54417U
70	125	55	59.2	67	1	1	92.3	251	1 500	2 300	52217	54217	54217U
	150	87	95.2	105	1.5	1	206	489	1 100	1 700	52317	54317	54317U
	190	135	143.4	157	2.1	1.1	327	826	710	1 100	52418	54418	54418U
75	135	62	69	76	1.1	1	117	326	1 400	2 100	52218	54218	54218U
	155	88	97.2	106	1.5	1	213	524	1 000	1 600	52318	54318	54318U
80	210	150	160	176	3	1.1	368	983	620	950	52420	54420	54420U
85	150	67	72.8	81	1.1	1	147	410	1 200	1 900	52220	54220	54220U
	170	97	105.4	115	1.5	1	236	596	940	1 450	52320	54320	54320U
90	230	166	—	—	3	1.1	379	1 070	550	850	52422	—	—
95	160	67	71.4	81	1.1	1	148	431	1 200	1 800	52222	54222	54222U
	190	110	118.4	128	2	1	280	754	810	1 250	52322	54322	54322U
	250	177	—	—	4	1.5	480	1 460	520	800	52424	—	—

[Remark] Standard cage types used for the above bearings are described earlier in this section.

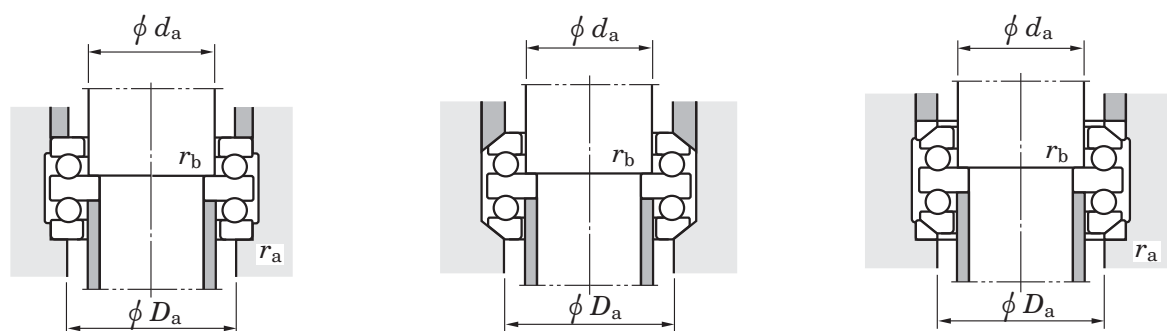

	Dimensions (mm)											Mounting dimensions (mm)				(Refer.) Mass (kg)	
	d_3 max.	D_1 min.	D_2	D_3	T_2	T_4	T_6	A	R	B	C	d_a min.	D_a max.	r_a max.	r_b max.	With flat back faces	With aligning seat races
	140	68	100	145	62	66.2	71	34	112	23	17.5	65	100	2	1	8.03	9.72
	100	67	82	105	28.5	30.2	33.5	38.5	80	10	9	65	82	1	0.6	1.36	1.70
	105	72	88	110	28.5	30.3	33.5	36.5	80	10	9	70	88	1	1	1.48	1.84
	115	67	90	120	40	43.4	47	34.5	90	15	12.5	65	90	1	0.6	2.90	3.66
	125	72	98	130	44	48.2	52	39	100	16	13	70	98	1	1	3.90	4.78
	150	73	110	155	65.5	69.1	74.5	28.5	112	24	19.5	70	110	2	1	9.71	11.6
	110	77	92	115	28.5	29.8	33.5	47.5	90	10	9.5	75	92	1	1	1.57	1.96
	135	77	105	140	48.5	52.6	56.5	32.5	100	18	15	75	105	1.5	1	4.83	6.08
	160	78	115	165	70.5	74.5	80.5	36.5	125	26	21	75	115	2	1	11.8	14.3
	115	82	98	120	29	30.5	34	45	90	10	10	80	98	1	1	1.69	2.09
	140	82	110	145	48.5	52.1	56.5	45.5	112	18	15	80	110	1.5	1	5.06	6.36
	170	83	125	175	73.5	77.7	83.5	30.5	125	27	22	80	125	2	1	14.0	16.6
	179.5	88	130	185	78.5	83.5	89.5	40.5	140	29	23	85	130	2	1	17.5	19.7
	125	88	105	130	33.5	35.6	39.5	49.5	100	12	11	85	105	1	1	2.34	2.90
	150	88	115	155	53	57.1	62	39	112	19	17.5	85	115	1.5	1	6.43	8.03
	189.5	93	140	195	82.5	86.7	93.5	34.5	140	30	25.5	90	140	2	1	19.6	22.8
	135	93	110	140	38	41.5	45	42	100	14	13.5	90	110	1	1	3.22	4.07
	155	93	120	160	53.5	58.1	62.5	36.5	112	19	18	90	120	1.5	1	6.60	8.44
	209.5	103	155	220	91.5	96.5	104.5	43.5	160	33	27	100	155	2.5	1	26.6	32.0
	150	103	125	155	41	43.9	48	49	112	15	14	100	125	1	1	4.29	5.25
	170	103	135	175	59	63.2	68	42	125	21	18	100	135	1.5	1	8.90	10.8
	229	113	—	—	101.5	—	—	—	—	37	—	110	170	2.5	1	34.9	—
	160	113	135	165	41	43.2	48	62	125	15	14	110	135	1	1	4.68	5.66
	189.5	113	150	195	67	71.2	76	47	140	24	20.5	110	150	2	1	13.8	16.3
	249	123	—	—	108.5	—	—	—	—	40	—	120	185	3	1.5	44.2	—

Double direction thrust ball bearings

d_2 100 ~ 190 mm

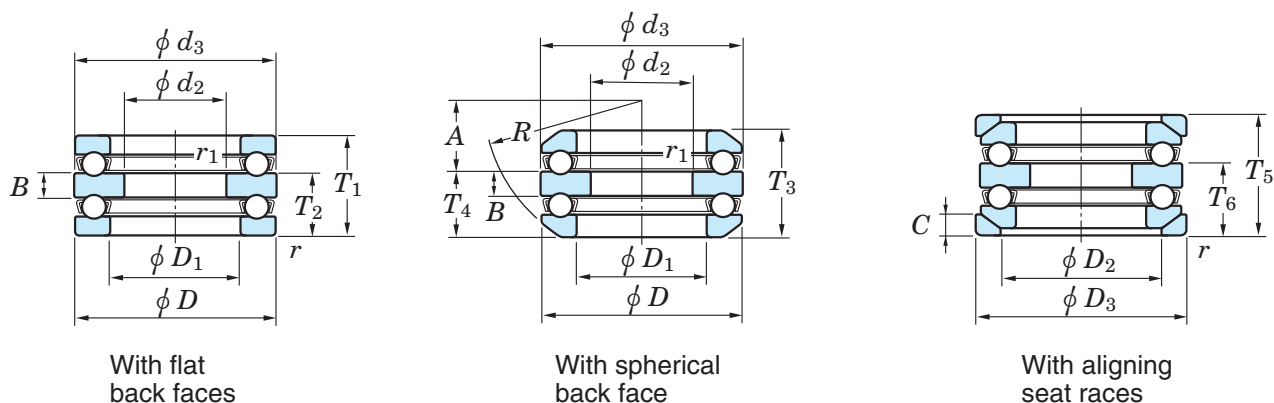

d_2	Boundary dimensions (mm)						Basic load ratings (kN)		Limiting speeds (min^{-1})		Bearing No.		
	D	T_1	T_3	T_5	r min.	r_1 min.	C_a	C_{0a}	Grease lub.	Oil lub.	With flat back faces	With spherical back faces	With aligning seat races
100	170	68	71.6	82	1.1	1.1	154	472	1 100	1 700	52224	54224	54224U
	210	123	131.2	143	2.1	1.1	325	931	710	1 100	52324	54324	54324U
	270	192	—	—	4	2	498	1 540	490	750	52426	—	—
110	190	80	85.8	96	1.5	1.1	203	622	970	1 500	52226	54226	54226U
	225	130	—	—	2.1	1.1	346	1 030	650	1 000	52326	—	—
	280	196	—	—	4	2	520	1 680	450	700	52428	—	—
120	200	81	86.2	99	1.5	1.1	215	669	940	1 450	52228	54228	54228U
	240	140	—	—	2.1	1.1	367	1 130	620	950	52328	—	—
	300	209	—	—	4	2	568	1 910	420	650	52430	—	—
130	215	89	95.6	109	1.5	1.1	244	768	840	1 300	52230	54230	54230U
	250	140	—	—	2.1	1.1	377	1 200	580	900	52330	—	—
	320	226	—	—	5	2	681	2 410	390	600	52432	—	—
135	340	236	—	—	5	2.1	755	2 730	360	550	52434	—	—
140	225	90	97.4	110	1.5	1.1	247	803	810	1 250	52232	54232	54232U
	270	153	—	—	3	1.1	470	1 570	550	850	52332	—	—
	360	245	—	—	5	3	742	2 730	320	500	52436	—	—
150	240	97	104.4	117	1.5	1.1	269	874	750	1 150	52234	54234	54234U
	250	98	102.4	118	1.5	2	294	986	710	1 100	52236	54236	54236U
	280	153	—	—	3	1.1	463	1 570	520	800	52334	—	—
	300	165	—	—	3	2	463	1 580	490	750	52336	—	—
160	270	109	116.4	131	2	2	298	1 010	650	1 000	52238	54238	54238U
	320	183	—	—	4	2	543	1 950	440	680	52338	—	—
170	280	109	115.6	133	2	2	314	1 110	620	950	52240	54240	54240U
	340	192	—	—	4	2	596	2 220	420	650	52340	—	—
190	300	110	115.2	134	2	2	342	1 310	580	900	52244	54244	54244U

[Remark] Standard cage types used for the above bearings are described earlier in this section.

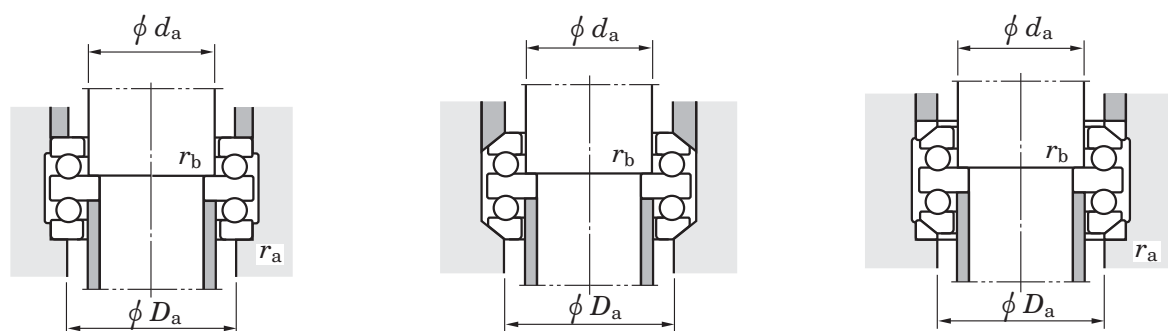

	Dimensions (mm)											Mounting dimensions (mm)				(Refer.) Mass (kg)	
	d_3 max.	D_1 min.	D_2	D_3	T_2	T_4	T_6	A	R	B	C	d_a min.	D_a max.	r_a max.	r_b max.	With flat back faces	With aligning seat races
	170	123	145	175	41.5	43.3	48.5	58.5	125	15	15	120	145	1	1	5.24	6.44
	209.5	123	165	220	75	79.1	85	58	160	27	22	120	165	2	1	17.2	22.9
	269	134	—	—	117	—	—	—	—	42	—	130	200	3	2	56.5	—
	189.5	133	160	195	49	51.9	57	63	140	18	17	130	160	1.5	1	7.72	9.29
	224	134	—	—	80	—	—	—	—	30	—	130	177	2	1	22.1	—
	279	144	—	—	120	—	—	—	—	44	—	140	206	3	2	60.6	—
	199.5	143	170	210	49.5	52.1	58.5	83.5	160	18	17	140	170	1.5	1	8.31	10.5
	239	144	—	—	85.5	—	—	—	—	31	—	140	190	2	1	27.8	—
	299	154	—	—	127.5	—	—	—	—	46	—	150	225	3	2	73.9	—
	214.5	153	180	225	54.5	57.8	64.5	74.5	160	20	20.5	150	180	1.5	1	10.6	13.6
	249	154	—	—	85.5	—	—	—	—	31	—	150	200	2	1	29.2	—
	319	164	—	—	138	—	—	—	—	50	—	160	240	4	2	90.3	—
	339	174	—	—	143	—	—	—	—	50	—	170	255	4	2	108	—
	224.5	163	190	235	55	58.7	65	70	160	20	21	160	190	1.5	1	12.2	14.6
	269	164	—	—	93	—	—	—	—	33	—	160	215	2.5	1	37.7	—
	359	184	—	—	148.5	—	—	—	—	52	—	180	270	4	2.5	126	—
	239.5	173	200	250	59	62.7	69	87	180	21	21.5	170	200	1.5	1	15.2	17.8
	249	183	210	260	59.5	61.7	69.5	108.5	200	21	21.5	180	210	1.5	2	15.9	19.6
	279	174	—	—	93	—	—	—	—	33	—	170	220	2.5	1	39.6	—
	299	184	—	—	101	—	—	—	—	37	—	180	240	2.5	2	50.9	—
	269	194	220	280	66.5	70.2	77.5	93.5	200	24	23	190	230	2	2	21.6	25.2
	319	195	—	—	111.5	—	—	—	—	40	—	190	255	3	2	64.9	—
	279	204	240	290	66.5	69.8	78.5	120.5	225	24	23	200	240	2	2	22.7	27.3
	339	205	—	—	117	—	—	—	—	42	—	200	270	3	2	77.8	—
	299	224	260	310	67	69.6	79	114	225	24	25	220	260	2	2	23.9	29.5

KOYO



Spherical thrust roller bearings

Spherical thrust roller bearings are designed to carry high axial loads. They can also support radial load if magnitude is no more than 55 % of the axial load being carried.

These bearings are not suitable for high-speed rotation.

Having a spherical housing race raceway surface, these bearings are self-aligning, adjusting to axial inclination.

They are usually used with oil lubrication.

Spherical thrust roller bearings



Bore diameter **60 – 500** mm

Boundary dimensions	As specified in JIS B 1512.
Tolerances	As specified in JIS B 1514-2, class 0. (refer to table 7-10 on p. A 69.)
Recommended fits	Refer to Table 9-8 on p. A 92.
Required minimum axial load	A certain degree of load is necessary in order for bearings to operate satisfactorily. (refer to p. A 110.)
Standard cage	Copper alloy machined cage (supplementary code : FY)
Allowable aligning angle	0.035 – 0.052 rad (2° – 3°) in general, depending on bearing series.
Equivalent axial load	Dynamic equivalent axial load $P_a = 1.2F_r + F_a$ Static equivalent axial load $P_{0a} \doteq 2.7F_r + F_a$ (Note : $F_r / F_a \leq 0.55$)

Spherical thrust roller bearings

d 60 ~ 160 mm

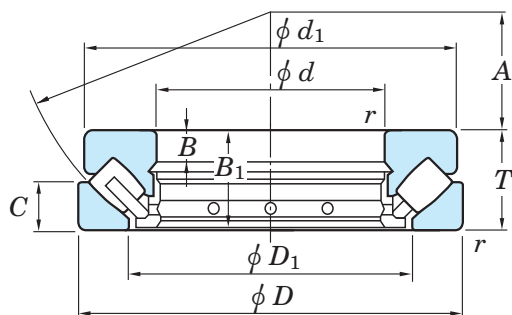

Boundary dimensions (mm)				Basic load ratings (kN)		Limiting speed (min ⁻¹) Oil lub.	Bearing No.	
d	D	T	r min.	C_a	C_{0a}			
60	130	42	1.5	319	884	2 700	29412R	
65	140	45	2	360	1 020	2 500	29413R	
70	150	48	2	387	1 100	2 300	29414R	
75	160	51	2	468	1 360	2 100	29415R	
80	170	54	2.1	505	1 480	2 000	29416R	
85	150	39	1.5	321	1 000	2 600	29317R	
	180	58	2.1	572	1 700	1 900	29417R	
90	155	39	1.5	330	1 050	2 500	29318R	
	190	60	2.1	658	2 010	1 800	29418R	
100	170	42	1.5	385	1 270	2 300	29320R	
	210	67	3	730	2 220	1 650	29420R	
110	190	48	2	502	1 690	2 000	29322R	
	230	73	3	896	2 810	1 500	29422R	
120	210	54	2.1	565	2 030	1 800	29324R	
	250	78	4	1 040	3 270	1 350	29424R	
130	225	58	2.1	715	2 440	1 700	29326R	
	270	85	4	1 200	3 870	1 250	29426R	
140	240	60	2.1	707	2 490	1 600	29328	
	280	85	4	1 260	4 080	1 250	29428R	
150	250	60	2.1	767	2 740	1 550	29330R	
	300	90	4	1 380	4 620	1 100	29430R	
160	270	67	3	862	3 070	1 400	29332	
	320	95	5	1 590	5 370	1 050	29432R	

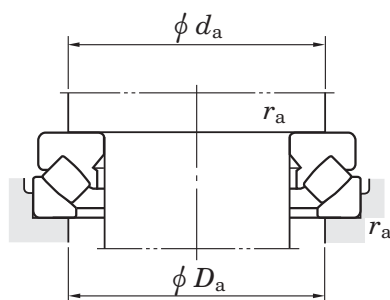

	Dimensions (mm)						Mounting dimensions (mm)			(Refer.) Mass (kg)
	d_1	D_1	B	B_1	C	A	d_a min.	D_a max.	r_a max.	
	123	89	15	39.5	20	38	90	108	1.5	2.75
	133	96	16	42.5	21	42	100	115	2	3.41
	142	103	17	45.5	23	44	105	125	2	4.16
	152	109	18	48	24	47	115	132	2	4.98
	162	117	19	51	26	50	120	140	2	5.95
	143.5 170	114 125	13 21	37 55	19 28	50 54	115 130	135 150	1.5 2	2.87 7.19
	148.5 180	117 132	13 22	37 57	19 29	52 56	120 135	140 157	1.5 2	3.06 8.28
	163 200	129 146	14 24	40 64	20.8 32	58 62	130 150	150 175	1.5 2.5	3.91 11.2
	182 220	143 162	16 26	45.5 69	23 35	64 69	145 165	165 190	2 2.5	5.67 14.7
	200 236	159 174	18 29	51 74	26 37	70 74	160 180	180 205	2 3	7.90 18.5
	215 255	171 189	19 31	55 81	28 41	76 81	170 195	195 225	2 3	9.45 23.5
	230 268	183 199	20 31	57 81	29 41	82 86	185 205	205 235	2 3	11.1 24.6
	240 285	194 214	20 32	57 86	29 44	87 92	195 220	215 250	2 3	11.7 29.6
	260 306	208 229	23 34	64 91	32 45	92 99	210 230	235 265	2.5 4	15.4 35.9

Spherical thrust roller bearings

d 170 ~ 320 mm

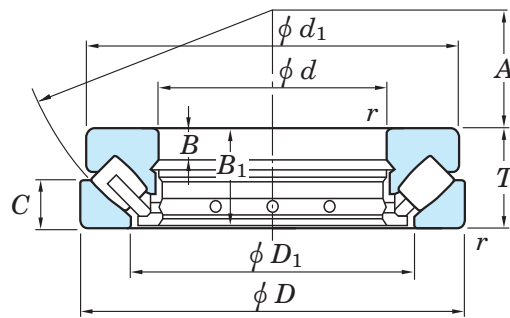

Boundary dimensions (mm)				Basic load ratings (kN)		Limiting speed (min ⁻¹)	Bearing No.	
d	D	T	r min.	C_a	C_{0a}	Oil lub.		
170	280	67	3	922	3 180	1 350	29334A 29434R	
	340	103	5	1 740	5 880	950		
180	300	73	3	896	3 170	1 250	29336 29436R	
	360	109	5	1 960	6 590	900		
190	320	78	4	1 170	4 230	1 150	29338 29438R	
	380	115	5	2 230	7 690	850		
200	280	48	2	513	2 170	1 600	29240 29340 29440R	
	340	85	4	1 360	5 040	1 050		
	400	122	5	2 460	8 470	800		
220	300	48	2	536	2 340	1 550	29244 29344 29444R	
	360	85	4	1 380	5 240	1 000		
	420	122	6	2 540	8 990	750		
240	340	60	2.1	822	3 670	1 250	29248 29348A 29448R	
	380	85	4	1 430	5 330	950		
	440	122	6	2 610	9 510	700		
260	360	60	2.1	838	3 720	1 200	29252 29352 29452R	
	420	95	5	1 540	6 040	850		
	480	132	6	3 100	11 100	650		
280	380	60	2.1	826	3 730	1 150	29256 29356 29456R	
	440	95	5	1 760	6 870	800		
	520	145	6	3 650	13 600	550		
300	420	73	3	1 060	4 880	950	29260 29360 29460R	
	480	109	5	1 970	7 780	700		
	540	145	6	3 880	14 900	550		
320	440	73	3	1 430	6 480	900	29264R 29364 29464R	
	500	109	5	2 310	9 380	650		
	580	155	7.5	4 160	16 100	500		

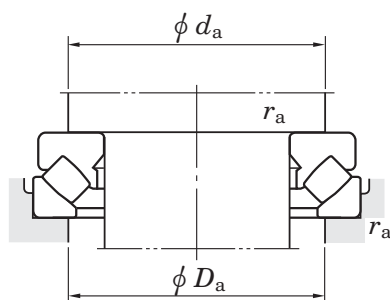

	Dimensions (mm)						Mounting dimensions (mm)			(Refer.) Mass (kg)
	d_1	D_1	B	B_1	C	A	d_a min.	D_a max.	r_a max.	
	270	216	23	64	32	96	220	245	2.5	15.4
	324	243	37	99	50	104	245	285	4	44.0
	290	232	25	69	35	103	235	260	2.5	20.7
	342	255	39	105	52	110	260	300	4	52.2
	308	246	27	74	38	110	250	275	3	25.1
	360	271	41	111	55	117	275	320	4	61.4
	271	236	15	45	24	108	235	255	2	8.90
	325	261	29	81	41	116	265	295	3	31.2
	380	286	43	117	59	122	290	335	4	73.0
	292	254	15	45	24	117	260	275	2	10.0
	345	280	29	81	41	125	285	315	3	33.3
	400	308	43	117	58	132	310	355	5	74.2
	330	283	19	57	30	130	285	305	2	16.7
	365	300	29	81	41	135	300	330	3	35.5
	420	326	43	117	59	142	330	375	5	83.0
	350	302	19	57	30	139	305	325	2	18.5
	405	329	32	91	45	148	330	365	4	51.5
	460	357	48	127	64	154	360	405	5	110
	370	323	19	57	30	150	325	345	2	19.5
	423	348	32	91	46	158	350	390	4	53.2
	495	387	52	140	68	166	390	440	5	137
	405	353	21	69	38	162	355	380	2.5	30.5
	460	379	37	105	50	168	380	420	4	74.9
	515	402	52	140	70	175	410	460	5	146
	430	372	21	69	38	172	375	400	2.5	32.7
	482	399	37	105	53	180	400	440	4	78.0
	555	435	55	149	75	191	435	495	6	179

Spherical thrust roller bearings

d 340 ~ 500 mm

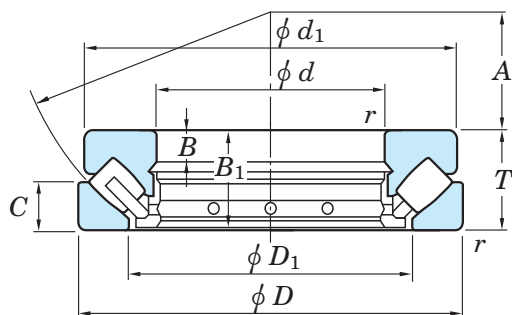

Boundary dimensions (mm)				Basic load ratings (kN)		Limiting speed (min ⁻¹)	Bearing No.	
d	D	T	r min.	C_a	C_{0a}	Oil lub.		
340	460	73	3	1 390	6 420	900	29268R 29368R 29468R	
	540	122	5	3 050	12 700	600		
	620	170	7.5	4 960	19 400	450		
360	500	85	4	1 310	6 080	750	29272 29372R 29472R	
	560	122	5	3 120	13 200	550		
	640	170	7.5	5 150	20 600	450		
380	520	85	4	1 380	6 610	700	29276 29376R 29476R	
	600	132	6	3 540	15 000	500		
	670	175	7.5	5 420	22 000	410		
400	540	85	4	1 580	7 610	700	29280 29380R 29480R	
	620	132	6	3 700	16 100	500		
	710	185	7.5	6 200	25 300	380		
420	580	95	5	1 850	8 750	600	29284 29384R 29484R	
	650	140	6	4 060	17 700	450		
	730	185	7.5	6 380	26 500	370		
440	600	95	5	1 870	8 970	600	29288 29388R 29488R	
	680	145	6	4 290	18 800	420		
	780	206	9.5	7 290	30 000	320		
460	620	95	5	1 950	9 620	550	29292 29392 29492R	
	710	150	6	3 680	15 800	400		
	800	206	9.5	7 520	31 600	300		
480	650	103	5	2 300	11 600	500	29296 29396 29496R	
	730	150	6	3 650	15 800	390		
	850	224	9.5	8 690	36 300	270		
500	870	224	9.5	8 650	36 400	270	294/500R	

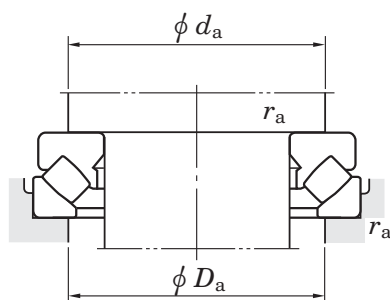

	Dimensions (mm)						Mounting dimensions (mm)			(Refer.) Mass (kg)
	d_1	D_1	B	B_1	C	A	d_a min.	D_a max.	r_a max.	
	445	395	21	69	37	183	395	420	2.5	34.7
	520	428	41	117	59	192	430	470	4	106
	590	462	61	164	82	201	465	530	6	224
	485	423	25	81	44	194	420	455	3	51.8
	540	448	41	117	59	202	450	495	4	110
	610	480	61	164	82	210	485	550	6	231
	505	441	27	81	42	202	440	475	3	52.8
	580	477	44	127	63	216	480	525	5	141
	640	504	63	168	85	230	510	575	6	263
	526	460	27	81	42	212	460	490	3	55.3
	596	494	44	127	64	225	500	550	5	144
	680	534	67	178	89	236	540	610	6	315
	564	489	30	91	46	225	490	525	4	75.4
	626	520	48	135	68	235	525	575	5	169
	700	556	67	178	89	244	560	630	6	330
	585	508	30	91	49	235	510	545	4	77.9
	655	548	49	140	70	245	550	600	5	190
	745	588	74	199	100	260	595	670	8	423
	605	530	30	91	46	245	530	570	4	81.0
	685	567	51	144	72	257	575	630	5	216
	765	608	74	199	100	272	615	690	8	438
	635	556	33	99	55	259	555	595	4	89.0
	705	590	51	144	72	270	595	650	5	218
	810	638	81	216	108	280	645	730	8	548
	830	661	81	216	107	290	670	750	8	562

KOYO

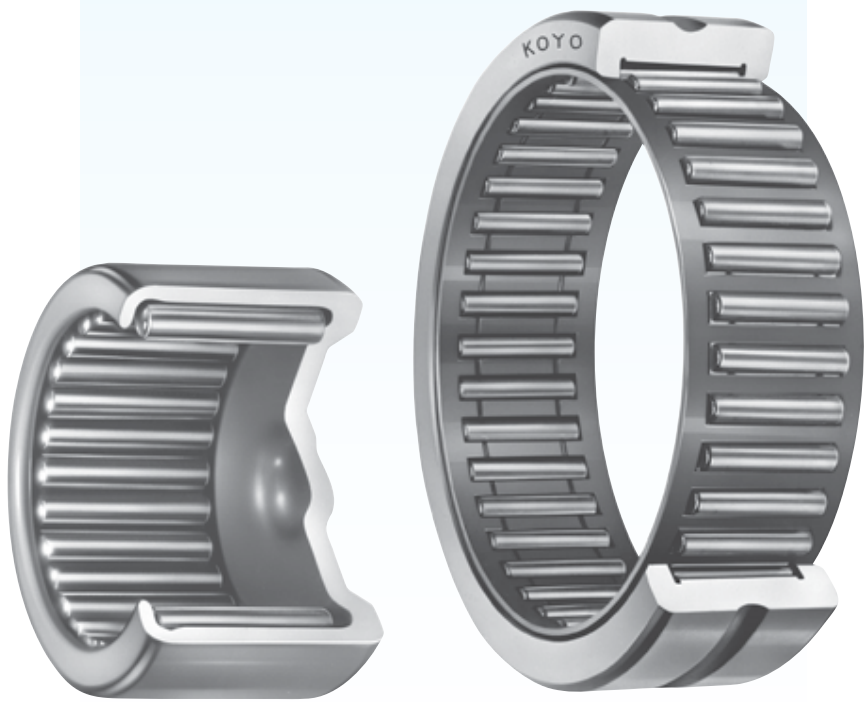

Needle roller bearings

Needle roller bearings are small in sectional height, therefore useful in making machinery smaller and lighter. This type of bearing is used in a wide range of machinery, such as automobiles, motor cycles, electric machines, machine tools, aerospace and office equipment.

- Compact, highly rigid and superior in load carrying performance, compared with other types of bearings.
- Excellent for carrying oscillating loads; contains many small diameter rollers.
- Widely employed in stud type and yoke type track rollers used as guide rollers in cam mechanisms or linear motion units.
Also used in miniature one-way clutches in the clutch mechanisms of office equipment, such as copying machines.

The catalog also covers bearings employing rollers other than those prescribed in JIS B 1506 "rollers for roller bearings".

Needle roller and cage assemblies

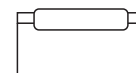

Bore diameter of a needle roller and cage assembly
6 – 95 mm

Drawn cup needle roller bearings

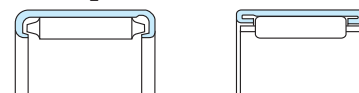

Full complement type With cage
Roller set bore diameter
4 – 50 mm

Machined ring needle roller bearings

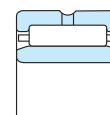

Roller set bore diameter
12 – 160 mm

Needle roller thrust bearings

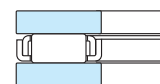

Bore diameter **10 – 100 mm**

Stud type track rollers (cam followers)

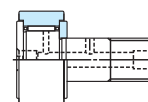

Outside diameter **13 – 90 mm**

Yoke type track rollers (roller followers)

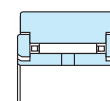

Outside diameter **16 – 90 mm**

Miniature one-way clutches (Refer.)

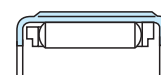

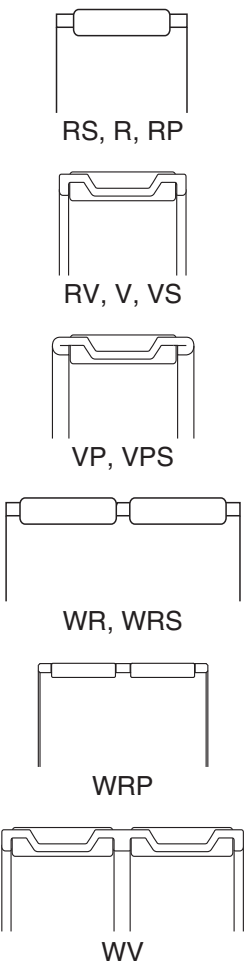
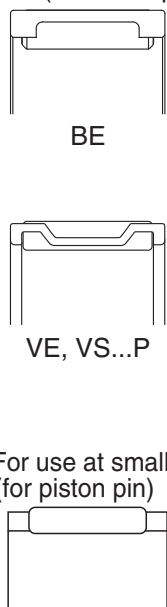
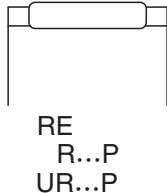
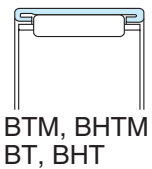
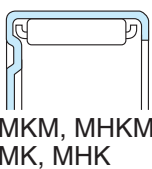
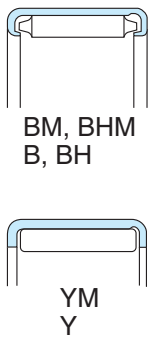
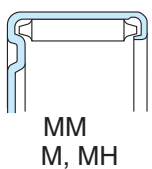

Roller set bore diameter **4 – 12 mm**

Table 1 Types of needle roller bearing

	Needle roller and cage assemblies		Drawn cup needle roller bearings	
	For general use	For use with connecting rods	With cage	Full complement type
Basic type	 <p>RS, R, RP</p> <p>RV, V, VS</p> <p>VP, VPS</p> <p>WR, WRS</p> <p>WRP</p> <p>WV</p>	<ul style="list-style-type: none"> For use at large end (for crank pin)  <p>BE</p> <p>VE, VS...P</p> <ul style="list-style-type: none"> For use at small end (for piston pin)  <p>RE R...P UR...P</p>	<ul style="list-style-type: none"> Open ends type  <p>BTM, BHTM BT, BHT</p> <ul style="list-style-type: none"> Closed end type  <p>MKM, MHKM MK, MHK</p>	<ul style="list-style-type: none"> Open ends type  <p>BM, BHM B, BH</p> <p>YM Y</p> <ul style="list-style-type: none"> Closed end type  <p>MM M, MH</p>
Tolerances	<ul style="list-style-type: none"> The tolerances of needle roller are as specified in JIS B 1506. (refer to Table 2.) Cage width tolerance is given in Table 3. 		<ul style="list-style-type: none"> This type of bearing becomes accurate in terms of performance and dimensions when it is press-fit inside the housing at a specified interference. Therefore, its roller set bore diameter should be measured with the bearing press-fit inside a ring gauge. (refer to Tables 4 and 5.) 	
Recommended fits and radial internal clearance	Recommended fit is given in Table 16.	To be determined according to engine type and operating conditions.	Recommended fit is given in Table 17.	
Shaft and housing specifications	<p>Table 23 gives the requirements for shafts and housings to which needle roller radial bearings are mounted.</p> <p>(for needle roller and cage assemblies used on connecting rods, refer to JTEKT separate catalog.)</p>			

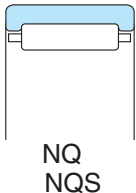
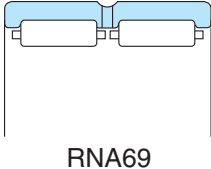
[Remark] *-marked item indicates the thrust washer or washer specified in JIS.

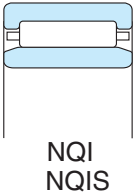
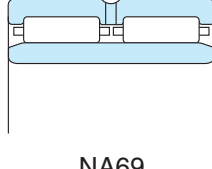
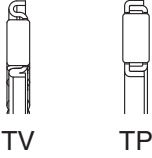
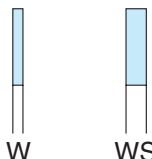
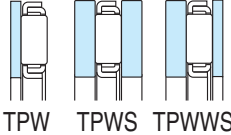
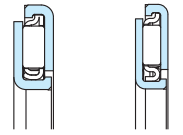
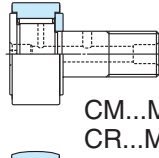
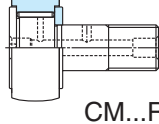
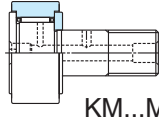
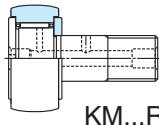
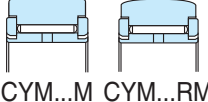
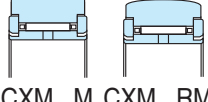
Machined ring needle roller bearings		Needle roller thrust bearings	Stud type track rollers (cam followers)	Yoke type track rollers (roller followers)
Without inner ring	With inner ring			
 <p>RNA49 RNA59</p>  <p>NQ NQS</p>  <p>RNA69</p>	 <p>NA49 NA59</p>  <p>NQI NQIS</p>  <p>NA69</p>	<ul style="list-style-type: none"> Needle roller and cage assembly  <p>TV TP</p> Race*  <p>W WS</p> Combination type (separable type)  <p>TPW TPWS TPWS</p> One-piece (non-separable type)  <p>TPK... TVK...</p> 	<ul style="list-style-type: none"> Full complement type  <p>CM...M CR...M</p>  <p>CM...RM</p> With cage  <p>KM...M</p>  <p>KM...RM</p> 	<ul style="list-style-type: none"> Full complement type  <p>CYM...M CYM...RM</p> With cage  <p>CXM...M CXM...RM</p>
<ul style="list-style-type: none"> As specified in JIS B 1536-1. (refer to Table 6 and 7.) 		<ul style="list-style-type: none"> The dimensional tolerance is given in Table 8 – 11. 	<ul style="list-style-type: none"> As specified in JIS B 1536 for the stud type track roller outer ring outside diameter and width tolerances, as well as the dimensional and running accuracy of yoke type track rollers. The tolerances of stud type track rollers are as shown in Table 12 – 14. The tolerances of yoke type track rollers are as shown in Table 15. 	
<ul style="list-style-type: none"> Recommended fit is as shown in Table 18. Radial internal clearance is as shown in Table 10-8 on p. A 100. For bearings which do not have an inner ring, the tolerance class of the roller set and roller complement bore diameters is F 6. Therefore, the radial internal clearance can be determined by choosing the shaft tolerance class. (refer to Table 19.) 		<p>Recommended fit is as shown in Table 20.</p>	<p>Fix the stud type track rollers to the stud tightly so that there will be no play between them. Recommended mounting holes of stud are as shown in Table 21.</p>	<p>Recommended fit is as shown in Table 22.</p>
<p>As shown in Table 23.</p>		<p>Table 24 gives the specifications for the fitting face.</p>		

[Tolerances of needle roller bearings]

Table 2 Tolerance grades of needle rollers (JIS B 1506)

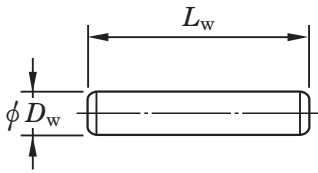

Unit : μm

Class	Single ¹⁾ plane diameter variation	Deviation ¹⁾ from circular form	Gauge lot ¹⁾ diameter variation
	$V_{D_{wp}}$ max.	Δ_{R_w} max.	$V_{D_{wL}}$ max.
2	1	1	2
3	1.5	1.5	3
5	2	2.5	5

Class	Actual ²⁾ length deviation	Recommended gauge <i>S</i>
	$\Delta_{L_{ws}}$	
2	h 13	0/- 2, - 1/- 3, - 2/- 4, - 3/- 5, - 4/- 6, - 5/- 7, - 6/- 8, - 7/- 9, - 8/- 10
3		0/- 3, - 1.5/- 4.5, - 3/- 6, - 4.5/- 7.5, - 6/- 9, - 7/- 10
5		0/- 5, - 3/- 8, - 5/- 10

[Notes] 1) Values apply only at middle of roller length.
2) Applied tolerance differs according to L_w division.

[Remark] Along the entire length of the roller, all the actually measured diameters should not exceed the actual maximum diameter at the middle of the entire length of the roller by the lengths shown below.
a) Class 2 : 0.5 μm b) Class 3 : 0.8 μm
c) Class 5 : 1 μm

Table 3 Tolerance of needle roller cage width *B*

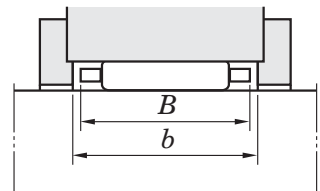

Bearing type	<i>B</i> deviation (mm)	
	upper	lower
R, RS, RP (Welded type), RV, V, VS, WR, WRS, WRP, WV	- 0.2	- 0.55
VP, VPS	- 0.2	- 0.7

[Remark] Values in Italics are prescribed in JTEKT standards.

[Reference] The guide width (*b*) should satisfy the equation : $b = B + x$ (x : 0.2 to 0 mm)

Table 4 Metric series drawn cup needle roller bearing inspecting gauge specifications

Unit : mm

Nominal bore diameter of rolling element complement F_w	Ring gauge	Plug gauge	
		Go end	No-go end
4	7.996	4.023	4.048
5	8.996	5.023	5.048
6	9.996	6.028	6.053
7	10.995	7.031	7.056
8	11.995 14.995	8.031	8.056
9	12.995 15.995	9.031	9.056
10	13.995 16.995	10.031	10.056
12	15.995 17.995 18.993	12.031	12.056
13	18.993	13.034	13.059
14	18.993 19.993 21.993	14.034	14.059
15	19.993 20.993 21.993	15.034	15.059
16	21.993 23.993	16.034	16.059
17	21.972 22.972 23.972	17.013	17.038
18	23.972 24.972	18.013	18.038
19	26.972	19.013	19.038
20	25.972 26.972	20.013	20.038
22	27.972 28.972 29.972	22.013	22.038
24	29.972 30.967 34.967	24.013	24.038
25	31.967 32.967	25.013	25.038
26	33.967	26.013	26.038
28	33.967 34.967 36.967	28.013	28.038
30	36.967 37.967 39.967	30.013	30.038
32	37.967 39.967 41.967	32.013	32.038
35	41.967 44.967	35.013	35.038
36	41.967 43.967 47.967	36.013	36.038
37	42.967 46.967	37.013	37.038
38	47.967	38.013	38.038
40	46.967 49.967	40.013	40.043
45	51.961 54.961	45.013	45.043
50	57.961 61.961	50.013	50.043
55	62.961	55.013	55.051

Table 5 Ring gauge specifications and roller set bore diameter tolerance (for bearings designed according to ISO standards)

Unit : mm

Nominal bore diameter of rolling element complement F_w	Nominal outside diameter D	Ring gauge	Nominal bore diameter of rolling element complement F_w tolerance	
			lower	upper
4	8	7.984	4.010	4.028
5	9	8.984	5.010	5.028
6	10	9.984	6.010	6.028
7	11	10.980	7.013	7.031
8	12 14	11.980 13.980	8.013	8.031
9	13 15	12.980 14.980	9.013	9.031
10	14 16	13.980 15.980	10.013	10.031
12	16 18	15.980 17.980	12.016	12.034
14	20 22	19.976 21.976	14.016	14.034
15	21 23	20.976 22.976	15.016	15.034
16	22 24	21.976 23.976	16.016	16.034
17	23 25	22.976 24.976	17.016	17.034
18	24 26	23.976 25.976	18.016	18.034
20	26 28	25.976 27.976	20.020	20.041
22	28 30	27.976 29.976	22.020	22.041
25	32 35	31.972 34.972	25.020	25.041
28	35 38	34.972 37.972	28.020	28.041
30	37 40	36.972 39.972	30.020	30.041
32	39 42	38.972 41.972	32.025	32.050
35	42 45	41.972 44.972	35.025	35.050
38	45 48	44.972 47.972	38.025	38.050
40	47 50	46.972 49.972	40.025	47.050
42	49 52	48.972 51.967	42.025	42.050
45	52 55	51.967 54.967	45.025	45.050
50	58	57.967	32.025	32.050
55	63	62.967	55.030	55.060
60	68	67.967	60.030	60.060
65	73	72.967	65.030	65.060
70	78	77.967	70.030	70.060

[Remark] The supplementary code "J" is added as a suffix to the bearing numbers that are designed according to ISO standards.

Table 6 Machined ring needle roller bearings variation of smallest single bore diameter of rolling element complement $F_{ws \min}$ ¹⁾ (for interchangeable bearings²⁾ and bearings without inner ring)

Unit : μm

Nominal bore diameter of rolling element complement F_w (mm)		$F_{ws \min}$ tolerance (F 6)	
over	up to	upper	lower
6	10	+ 22	+ 13
10	18	+ 27	+ 16
18	30	+ 33	+ 20
30	50	+ 41	+ 25
50	80	+ 49	+ 30
80	120	+ 58	+ 36
120	180	+ 68	+ 43
180	250	+ 79	+ 50

- [Notes] 1) The smallest single bore diameter of rolling element complement is the diameter of a cylinder whose radial internal clearance disappears completely, at least in one radial direction.
- 2) A group of bearings with inner rings that have the same bearing number. Outer ring, cage and needle roller assemblies and inner rings are interchangeable among them.

Table 7 Radial bearing tolerances = JIS B 1536 =

(1) Inner ring

Nominal bore diameter <i>d</i> (mm)		Single plane mean bore diameter deviation								Single plane bore diameter variation V_{dsp}				Mean bore diameter variation V_{dmp}			
		Δ_{dmp}								Diameter series 9							
		class 0		class 6		class 5		class 4		class 0	class 6	class 5	class 4	class 0	class 6	class 5	class 4
over	up to	upper	lower	upper	lower	upper	lower	upper	lower	max.				max.			
2.5	10	0	-8	0	-7	0	-5	0	-4	10	9	5	4	6	5	3	2
10	18	0	-8	0	-7	0	-5	0	-4	10	9	5	4	6	5	3	2
18	30	0	-10	0	-8	0	-6	0	-5	13	10	6	5	8	6	3	2.5
30	50	0	-12	0	-10	0	-8	0	-6	15	13	8	6	9	8	4	3
50	80	0	-15	0	-12	0	-9	0	-7	19	15	9	7	11	9	5	3.5
80	120	0	-20	0	-15	0	-10	0	-8	25	19	10	8	15	11	5	4
120	150	0	-25	0	-18	0	-13	0	-10	31	23	13	10	19	14	7	5
150	180	0	-25	0	-18	0	-13	0	-10	31	23	13	10	19	14	7	5
180	250	0	-30	0	-22	0	-15	0	-12	38	28	15	12	23	17	8	6

[Remark] Values in Italics are prescribed in JTEKT standards.

S_d : Perpendicularity of inner ring face with respect to the bore

(2) Outer ring

Nominal outside diameter <i>D</i> (mm)		Single plane mean outside diameter deviation								Single plane outside diameter variation V_{Dsp}				Mean outside diameter variation V_{Dmp}			
		Δ_{Dmp}								Diameter series 9							
		class 0		class 6		class 5		class 4		class 0 ¹⁾	class 6 ¹⁾	class 5	class 4	class 0 ¹⁾	class 6 ¹⁾	class 5	class 4
over	up to	upper	lower	upper	lower	upper	lower	upper	lower	max.				max.			
6	18	0	-8	0	-7	0	-5	0	-4	10	9	5	4	6	5	3	2
18	30	0	-9	0	-8	0	-6	0	-5	12	10	6	5	7	6	3	2.5
30	50	0	-11	0	-9	0	-7	0	-6	14	11	7	6	8	7	4	3
50	80	0	-13	0	-11	0	-9	0	-7	16	14	9	7	10	8	5	3.5
80	120	0	-15	0	-13	0	-10	0	-8	19	16	10	8	11	10	5	4
120	150	0	-18	0	-15	0	-11	0	-9	23	19	11	9	14	11	6	5
150	180	0	-25	0	-18	0	-13	0	-10	31	23	13	10	19	14	7	5
180	250	0	-30	0	-20	0	-15	0	-11	38	25	15	11	23	15	8	6
250	315	0	-35	0	-25	0	-18	0	-13	44	31	18	13	26	19	9	7

[Note] 1) Shall be applied when locating snap ring is not fitted.

[Remark] Values in Italics are prescribed in JTEKT standards.

S_D : Perpendicularity of outer ring outside surface with respect to the face

Δ_{Cs} : Deviation of a single outer ring width

Unit : μm

Radial runout of assembled bearing inner ring K_{ia}				S_d		Single inner ring width deviation ΔB_s								Inner ring width variation V_{Bs}				
class 0	class 6	class 5	class 4	class 5	class 4	class 0		class 6		class 5		class 4		class 0	class 6	class 5	class 4	class 2
max.				max.		upper	lower	upper	lower	upper	lower	upper	lower	max.				
10	6	4	2.5	7	3	0	-120	0	-120	0	-40	0	-40	15	15	5	2.5	1.5
10	7	4	2.5	7	3	0	-120	0	-120	0	-80	0	-80	20	20	5	2.5	1.5
13	8	4	3	8	4	0	-120	0	-120	0	-120	0	-120	20	20	5	2.5	1.5
15	10	5	4	8	4	0	-120	0	-120	0	-120	0	-120	20	20	5	3	1.5
20	10	5	4	8	5	0	-150	0	-150	0	-150	0	-150	25	25	6	4	1.5
25	13	6	5	9	5	0	-200	0	-200	0	-200	0	-200	25	25	7	4	2.5
30	18	8	6	10	6	0	-250	0	-250	0	-250	0	-250	30	30	8	5	2.5
30	18	8	6	10	6	0	-250	0	-250	0	-250	0	-250	30	30	8	5	4
40	20	10	8	11	7	0	-300	0	-300	0	-300	0	-300	30	30	10	6	5

Unit : μm

Radial runout of assembled bearing outer ring K_{ea}				S_D		ΔC_s		Ring width variation V_{Cs}			
class 0	class 6	class 5	class 4	class 5	class 4	class 0, 6, 5, 4		class 0	class 6	class 5	class 4
max.				max.		upper	lower	max.			
15	8	5	3	8	4	Shall conform to the tolerance ΔB_s on d of the same bearing		5	2.5	5	2.5
15	9	6	4	8	4						
20	10	7	5	8	4						
25	13	8	5	8	4			6	3		
35	18	10	6	9	5						
40	20	11	7	10	5			8	4		
45	23	13	8	10	5						
50	25	15	10	11	7			8	5		
60	30	18	11	13	8	10	7				
								11	7		

Table 8 Tolerances for needle roller and cage thrust assemblies (type code : TV, TP) = JIS B 1536 =

(1) Bore diameter Unit : μm					(2) Outside diameter Unit : μm				
Cage bore diameter d_c (mm)		Smallest single bore ($d_{cs \min}$) diameter tolerance ¹⁾		Single plane bore diameter variation V_{dcsp}	Cage outside diameter D_c (mm)		Largest single outside ($D_{cs \max}$) diameter tolerance ¹⁾		Single plane outside diameter variation V_{Dcsp}
over	up to	upper	lower	max.	over	up to	upper	lower	max.
6	10	+115	+25	90	18	30	-110	-320	210
10	18	+142	+32	110	30	40	-120	-370	250
18	30	+170	+40	130	40	50	-130	-380	250
30	50	+210	+50	160	50	65	-140	-440	300
50	80	+250	+60	190	65	80	-150	-450	300
80	120	+292	+72	220	80	100	-170	-520	350
					100	120	-180	-530	350
					120	140	-200	-600	400

[Note] 1) The tolerances indicate the limits of differences between $d_{cs \min}$ and d_c .

[Remark] The tolerances of thickness conform to JIS B 1506 in a similar manner to roller diameter (D_w) (refer to page B 378).

[Note] 1) The tolerances indicate the limits of differences between $D_{cs \max}$ and D_c .

[Remark] The tolerances of thickness conform to JIS B 1506 in a similar manner to roller diameter (D_w) (refer to page B 378).

Table 9 Tolerances for races = JIS B 1536 = (Indicates the thrust washer specified in JIS)

(1) Bore diameter (type code : W) Unit : μm					(2) Outside diameter (type code : W) Unit : μm				
Race bore diameter d (mm)		Smallest single bore ($d_{s \min}$) diameter tolerance ¹⁾		Single plane bore diameter variation V_{dsp}	Race outside diameter D (mm)		Largest single outside ($D_{s \max}$) diameter tolerance ¹⁾		Single plane outside diameter variation V_{Dsp}
over	up to	upper	lower	max.	over	up to	upper	lower	max.
6	10	+175	+25	120	18	30	-40	-250	330
10	18	+212	+32	180	30	50	-50	-300	390
18	30	+250	+40	210	50	80	-60	-360	460
30	50	+300	+50	250	80	120	-72	-422	540
50	80	+360	+60	300	120	180	-85	-485	630
80	120	+422	+72	350					

[Note] 1) The tolerances indicate the limits of differences between $d_{s \min}$ and d .

[Remark] Tolerances of thickness (S) shall be equivalent to tolerance class js12 of JIS B 0401-2.

[Note] 1) The tolerances indicate the limits of differences between $D_{s \max}$ and D .

[Remarks] 1. Tolerances of thickness (S) shall be equivalent to tolerance class js12 of JIS B 0401-2.
2. Values in Italics are prescribed in JTEKT standards.

Table 10 Tolerances for races (Indicates the washer specified in JIS)

(1) Bore diameter (type code : WS) Unit : μm					(2) Outside diameter (type code : WS) Unit : μm				
Race bore diameter d (mm)		Smallest single bore ($d_{s \min}$) diameter tolerance ¹⁾		Single plane bore diameter variation V_{dsp}	Race outside diameter D (mm)		Largest single outside ($D_{s \max}$) diameter tolerance ¹⁾		Single plane outside diameter variation V_{Dsp}
over	up to	upper	lower	max.	over	up to	upper	lower	max.
6	10	+175	+25	120	18	30	-40	-250	330
10	18	+212	+32	180	30	50	-50	-300	390
18	30	+250	+40	210	50	80	-60	-360	460
30	50	+300	+50	250	80	120	-72	-422	540
50	80	+360	+60	300	120	180	-85	-485	630
80	120	+422	+72	350					

[Note] 1) The tolerances indicate the limits of differences between $d_{s \min}$ and d .

[Remarks] 1. Tolerances of thickness (S) shall be equivalent to tolerance class js12 of JIS B 0401-2.
2. Values in Italics are prescribed in JTEKT standards.

[Note] 1) The tolerances indicate the limits of differences between $D_{s \max}$ and D .

[Remarks] 1. Tolerances of thickness (S) shall be equivalent to tolerance class js12 of JIS B 0401-2.
2. Values in Italics are prescribed in JTEKT standards.

Table 11 Tolerances for non-separable needle roller thrust bearings (type code : TVK, TPK)

(1) Bore diameter Unit : μm					(2) Outside diameter Unit : μm				
Race bore diameter d (mm)		Smallest single bore ($d_{s\text{ min}}$) diameter tolerance ¹⁾		Single plane bore diameter variation $V_{d\text{ sp}}$	Race outside diameter D (mm)		Largest single outside ($D_{s\text{ max}}$) diameter tolerance ¹⁾		Single plane outside diameter variation $V_{D\text{ sp}}$
over	up to	upper	lower	max.	over	up to	upper	lower	max.
18	30	+250	+40	210	30	50	-50	-300	250
30	50	+300	+50	250	50	80	-60	-360	300
50	80	+360	+60	300	80	120	-72	-422	350

[Note] 1) The tolerances indicate the limits of differences between $d_{s\text{ min}}$ and d .

[Remark] Values in Italics are prescribed in JTEKT standards.

[Note] 1) The tolerances indicate the limits of differences between $D_{s\text{ max}}$ and D .

[Remark] Values in Italics are prescribed in JTEKT standards.

Table 12 Outer ring tolerance of stud type track rollers (cam followers) = JIS B 1536 =

(1) Metric series Unit : μm									
Nominal outside diameter D (mm)		Single plane mean outside diameter deviation $\Delta_{D\text{ mp}}$				Single outer ring width deviation $\Delta_{C\text{ s}}$		Radial runout of assembled bearing outer ring K_{ea}	
		Cylindrical outside surface		Crowning outside surface					
over	up to	upper	lower	upper	lower	upper	lower	max.	
10	18	0	-8	0	-50	0	-120	15	
18	30	0	-9	0	-50	0	-120	15	
30	50	0	-11	0	-50	0	-120	20	
50	80	0	-13	0	-50	0	-120	25	
80	120	0	-15	0	-50	0	-120	35	

[Remark] Values in Italics are prescribed in JTEKT standards.

Table 13 Tolerances of shank diameter

(1) Metric series Unit : μm			
Shank diameter d_1 (mm)		Deviation of a single shank diameter $\Delta_{d1\text{ s}}$	
over	up to	upper	lower
3	6	0	-12
6	10	0	-15
10	18	0	-18
18	30	0	-21

Table 14 Tolerances of shank length

Shank length B_2 (mm)	Deviation of a single shank length $\Delta_{B2\text{ s}}$	
	upper	lower
Total dimensions	+0.8	-0.8

[Remark] Values in Italics are prescribed in JTEKT standards.

Table 15 Tolerances of yoke type track rollers (metric series) = JIS B 1536 =

(1) Inner ring Unit : μm						(2) Outer ring Unit : μm						
Nominal bore diameter d (mm)		Single plane mean bore diameter deviation $\Delta_{d\text{ mp}}$		Single inner ring width deviation $\Delta_{B\text{ s}}$		Nominal outside diameter D (mm)		Single plane mean outside diameter deviation $\Delta_{D\text{ mp}}$		Single outer ring width deviation $\Delta_{C\text{ s}}$		Radial runout of assembled bearing outer ring K_{ea}
								Cylindrical outside surface				
over	up to	upper	lower	upper	lower	over	up to	upper	lower	upper	lower	max.
2.5	10	0	-8	0	-180	10	18	0	-8	0	-120	15
10	18	0	-8	0	-210	18	30	0	-9	0	-120	15
18	30	0	-10	0	-210	30	50	0	-11	0	-120	20
30	50	0	-12	0	-250	50	80	0	-13	0	-120	25
						80	120	0	-15	0	-120	35

[Remark] Values in Italics are prescribed in JTEKT standards.

[Remark] Values in Italics are prescribed in JTEKT standards.

[Recommended fit and internal clearance]

Table 16 Recommended fit for needle roller and cage assemblies

Conditions	Tolerance class		
	Shaft		Housing bore
	$F_w \leq 50\text{mm}$	$F_w > 50\text{mm}$	
High accuracy, impact load, oscillating motion	js 5	h 5	G 6
General	h 5	g 5	
High temperature, large shaft deflection, large misalignment	f 6		

Table 17 Recommended fit for drawn cup needle roller bearings

Distinction	Tolerance class		
	Shaft	Housing bore	
		Steel or cast iron	Light alloy, or steel or cast iron of 6 mm or less in thickness
Inner ring rotation	h 6	N 7	R 7 or S 7
Outer ring rotation	f 6	R 7	

[Remarks] 1. When the shaft makes oscillatory motions, the shaft diameter should be 0.013 mm larger than the recommended tolerance.
 2. When the bearing is provided with an inner ring, the shaft tolerance class j 6 should be selected.

Table 18 Recommended fit for machined ring needle roller bearings

(1) Recommended fits of inner ring and shaft

Operating condition		Shaft diameter (mm)	Class of shaft tolerance range	Applications (for reference)
Stationary inner ring load	Inner ring needs to move smoothly on shaft.	All shaft diameters	g 6	Stationary shaft wheels, tension pulleys, rope sheaves etc.
	Inner ring does not need to move smoothly on shaft.		h 6	
	High accuracy or noiseless rotation is required.		h 5	
Rotating inner ring load	Light load	40 mm or less	js 6	Electric appliances, machine tools, pumps, blowers, carriers etc.
	Normal load	40 mm or less	k 5	Electric motors, turbines, internal combustion engines, wood-working machines etc.
		over 40 mm or less	m 5	
		over 100 mm	m 6	
	Heavy load or impact load	140 mm or less	n 6	Railway rolling stock axle journals, traction motors
over 140 mm		p 6		

(2) Recommended fits of the outer ring and housing

Operating condition		Class of housing bore tolerance range	Applications (for reference)
Rotating outer ring load	Heavy load with shock	P 7	Fly wheels
	Normal load	N 7	Loose wheels, crank shaft, gears
	Light fluctuating load	M 7	Rope pulley, jockey puller
Indeterminate direction load	Eccentric pump wheel		
Indeterminate direction load	Extreme impact load	K 7	Compressor
	Normal load	J 7	Compressor, crank shaft
	Light load		
Stationary outer ring load	Split housing, normal load	H 7	General use
	High accuracy and rigidity are required	K 6	Machine tool spindle

[Notes] 1) This table is applicable to cast iron or steel housing. For light alloy housings, somewhat more interference fits than shown are recommended.

2) Interference fits larger than J 7 should not be used in split housings.

Table 19 Relation between tolerance class of a shaft provided with a machined ring needle roller bearing (without inner ring) and radial internal clearance

Roller set/roller complement bore diameter (mm)	C 2	C N	C 3	C 4
Over 3 up to 180	k 5	h 5	f 6	e 6

Table 20 Recommended fit for needle roller thrust bearings

Distinction	Type code	Guide	Tolerance class	
			Shaft	Housing bore
Needle roller and cage thrust assembly	TV TP	Inside	h 8	–
		Outside	–	H 8
Race ^{1) 2)}	W WS	Inside	h 8	–
		Outside	–	H 8
Non-separable bearing	TVK (TPK) ...JL TVK (TPK) ...J TVK (TPK) ...L	Inside	h 8	–
		Outside	–	H 8

[Notes] 1) Type code W indicates the thrust washer specified in JIS.

2) Type code WS indicates the washer specified in JIS.

[Remark] This tolerance class is applicable when the tolerances of bore and outside diameters of bearings are standard.

Table 21 Tolerances for stud fitting bore

Bearing type	Tolerance class
CM, KM	H 7

Table 22 Recommended fit for yoke type track rollers (roller followers)

Degree of loading	Shaft tolerance class
Light or medium load	g 6 or h 6
Heavy load	k 6

[Remark] Because yoke type track rollers (roller followers) are generally used with the outer ring rotation, they should be attached to the shaft by transition fitting or clearance fitting. If the application involves heavy loading, the shaft should be hardened and the track roller should be attached by interference fitting.

[Shaft and housing specifications]

Table 23 Specifications of needle roller bearing shafts and housings

Item	Shaft		Housing bore	
	Raceway surface	Fitting surface	Raceway surface	Fitting surface
Roundness	Best if less than one half or one third of the shaft diameter tolerance		Best if less than one half or one third of the bore diameter tolerance	
Cylindricity	5 μm or less per 25 mm, or one half or less of the shaft diameter tolerance		5 μm or less per 25 mm, or one half or less of the bore diameter tolerance	
Roughness (Ra)	0.4 a or less	0.8 a or less	0.6 a or less	1.6 a or less
Hardness	58 HRC or harder ¹⁾ (60 to 64 HRC are best.)	—	58 HRC or harder ¹⁾ (60 to 64 HRC are best.)	—

[Note] 1) Case hardened steel which is carburized or induction-hardened should not only meet the surface hardness requirement specified above but also have a case depth of 52.3 HRC (550 HV) to a depth in the range $(0.08 \text{ to } 0.1) \times D_w$ mm. (D_w : roller diameter)
In general, 30 thru 45 HRC is best for the center hardness.

Table 24 Needle roller thrust bearing mounting surface specifications



Squareness		25 μm or less per 25 mm
		12.5 μm or less per 25 mm
Roughness (Ra)	0.4 a or less	
Hardness	58 HRC or harder (60 thru 64 HRC is best.) (refer to the note for Table 23 above regarding depth.)	

Table 25 Track capacity of stud type and yoke type track rollers (cam and roller followers)

- Track capacity is the maximum load receivable without deformation or indentation of track surfaces contacted by the outer rings of track rollers to allow the track to be used continuously. The values in the specification table are track capacities obtained using track rollers with cylindrical outside surfaces made of HRC 40 steel.
- Track capacity of the type track rollers with spherical outside surface is 80% of the values listed in the specification table.
- To obtain track capacity for hardness out of standard, multiply the track capacities by track capacity coefficient listed in the table at right.

Hardness (HRC)	Track capacity coefficient
26	0.48
32	0.64
36	0.79
40	1
44	1.31
47	1.59
50	1.99
53	2.43
56	2.90
58	3.23

Needle roller and cage assemblies

F_w 9 ~ (15) mm

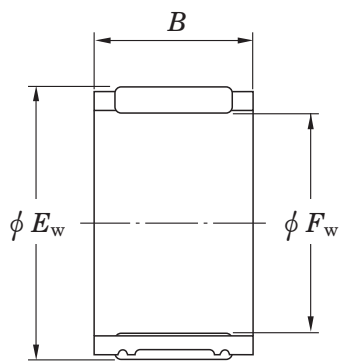

RS, R, RP

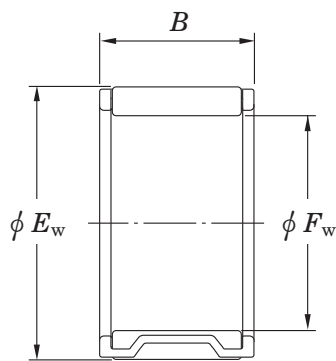

RV, V, VS

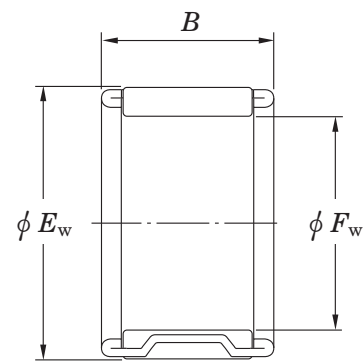

VP, VPS

Boundary dimensions (mm)			Basic load ratings (kN)		Limiting speeds (min ⁻¹)	Bearing No.	Special series (Cage)	(Refer.) Mass (g)
F_w	E_w	B	C_r	C_{0r}	Oil lub.			
9	12	10	3.8	4.0	43 000	RS091210	—	2.9
	14	18	9.1	9.0	41 000	RF091418	Polyamide	5.3
10	13	13	5.8	7.0	41 000	R10/13	—	4.0
	13	20	5.0	5.8	41 000	RF101320	Polyamide	2.4
	14	8	4.5	4.3	40 000	RS10/8-1	—	3.5
	14	10	5.1	5.0	40 000	RS10/10	—	4.3
	14	13	7.0	7.4	40 000	RS10/13	—	5.5
	15	18	10.5	10.9	37 000	RP101518	Welded	7.8
12	15	13	6.3	8.2	36 000	R12/13	—	4.7
	16	20	9.5	11.5	35 000	12R1620A	—	10
	17	11.5	8.2	8.3	34 000	RV121712A-2	—	6.6
13	17	10	5.9	6.4	33 000	RS131710-2	—	5.5
	17	12	7.3	8.4	33 000	RS131712	—	6.5
	18	15	10.2	11.2	32 000	13R1815	—	10
14	18	10	5.8	6.5	31 000	RS141810Q2	—	6.0
	18	15	9.6	12.3	31 000	RS141815	—	8.5
	18	17	10.1	13.2	31 000	R14/17A	—	10
	19	9	7.0	7.1	30 000	RV141909P1	—	5.7
	19	18	12.3	14.6	30 000	RS141918	—	13
15	19	7.8	4.7	5.0	29 000	RS151908A	—	5.0
	19	10	6.3	7.2	29 000	R15/10-1	—	6.1
	19	13	8.7	10.9	29 000	R15/13	—	7.9
	19	17	10.5	14.0	29 000	R15/17	—	10
	19	20	12.6	17.7	29 000	R15/20	—	12
	20	13	10.4	11.9	29 000	VS15/13	—	8.6
	20	18	13.8	17.2	29 000	RS15/18A	—	14
	20	20	16.2	21.2	29 000	VS15/20	—	12

[Note] 1) For further information, consult with JTEKT.

[Remark] Limiting speed of grease lubrication should be kept to under 60 % of that for oil lubrication.

F_W (15) ~ (20) mm

ϕE_w : Roller set outside diameter

ϕF_w : Roller set bore diameter

Boundary dimensions (mm)			Basic load ratings (kN)		Limiting speeds (min ⁻¹)	Bearing No.	Special series (Cage)	(Refer.) Mass (g)
F_w	E_w	B	C_r	C_{Or}	Oil lub.			
15	21	9	7.4	6.9	28 000	RV152109-4	—	7.8
	21	17	13.4	14.8	28 000	RS152117	—	16
16	20	13	9.4	12.5	28 000	R16/13	Width tolerance special ¹⁾	8.5
	21	26	19.9	28.0	27 000	16VP2126	Width tolerance special ¹⁾	16
	22	12	9.6	9.6	26 000	16VS2212-2	—	11
	22	24	20.4	25.6	26 000	RS16/24	Width tolerance special ¹⁾	23
	22	28.4	21.7	27.9	26 000	VPS16/28A	—	24
17	20	6	3.1	3.6	27 000	RF172006	With single split polyamide	1.3
	20	8	3.8	4.7	27 000	RF172008A-2	With single split polyamide	1.7
	21	10	6.8	8.3	26 000	R17/10	—	6.8
	21	13	9.4	12.6	26 000	R17/13	—	8.8
	21	15	10.7	15.0	26 000	R17/15	—	10
	21	17	11.3	16.1	26 000	RS172117	—	11
	22	20	15.2	20.2	26 000	17R2220	—	17
	23	13	11.4	12.4	25 000	RS17/13	—	14
18	22	13	9.5	13.1	25 000	R18/13	—	9.2
	22	16	11.1	16.0	25 000	R18/16-8	—	11
	22	17	11.9	17.4	25 000	R18/17	—	12
	24	17	15.1	17.9	24 000	RS182417	Width tolerance special ¹⁾	19
	25	17	17.8	20.1	23 000	RP182517	Welded	19
	26	21.9	19.1	20.3	23 000	RF182622A-1	Polyamide	19
	26	21.9	22.7	25.5	23 000	RV182622A-2	—	31
	19	24	22	16.6	23.3	23 000	RS192422	—
20	24	10	7.2	9.4	23 000	R20/10	—	7.9
	24	13	9.8	14.0	23 000	R20/13P	—	10
	25	25	18.8	27.9	22 000	RF202525	Polyamide	14

Needle roller and cage assemblies

F_w (20) ~ (22) mm

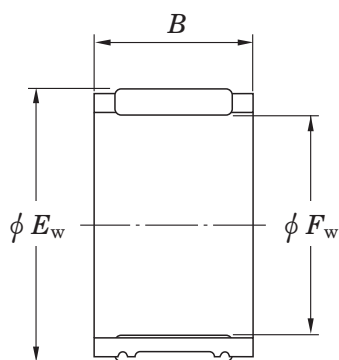

RS, R, RP

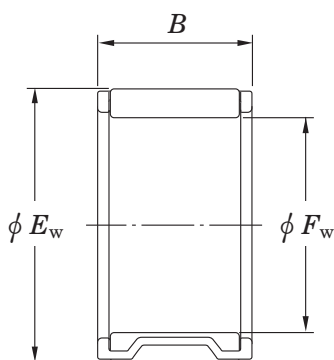

RV, V, VS

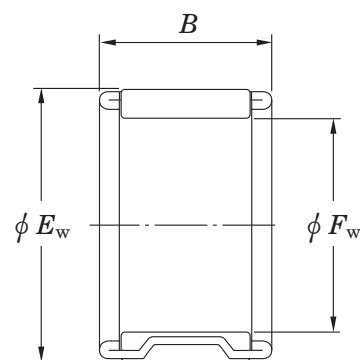

VP, VPS

Boundary dimensions (mm)			Basic load ratings (kN)		Limiting speeds (min ⁻¹)	Bearing No.	Special series (Cage)	(Refer.) Mass (g)
F_w	E_w	B	C_r	C_{0r}	Oil lub.			
20	26	11.6	10.7	11.9	22 000	20VS2612	Width tolerance special ¹⁾	12
	26	12	12.8	15.1	22 000	RV202612-4	—	14
	26	14	14.1	17.0	22 000	VS20/14A	—	15
	26	17	15.8	19.6	22 000	RS20/17	—	21
	26	18.8	17.4	22.3	22 000	RP202619A	—	17
	26	20	18.9	24.7	22 000	VP20/20-1	Width tolerance special ¹⁾	19
	26	30	26.8	38.9	22 000	RS202630	Welded	39
	27	15	16.2	18.3	21 000	20V2715	—	19
	27	29	25.4	32.6	21 000	20V2729	—	37
	28	20	24.1	28.2	21 000	RP202820	—	28
	28	25	28.8	35.4	21 000	20V2825B	—	37
	30	15	18.2	17.1	20 000	RV203015	—	30
21	29	22.5	23.7	27.6	20 000	RF212923A	Polyamide	24
22	26	12	9.6	14.1	21 000	RS222612	—	10
	26	13	10.4	15.6	21 000	R22/13-1	—	11
	26	17	13.0	20.7	21 000	R22/17	—	14
	27	20	17.0	25.2	20 000	RS222720	—	21
	28	11	9.5	10.5	20 000	RS222811	—	15
	28	14	13.2	15.9	20 000	22VS2814E	—	16
	28	17	16.1	20.7	20 000	RS22/17	—	22
	28	22.5	21.3	29.6	20 000	RP222823A	Welded, Width tolerance special ¹⁾	25
	28	23	24.2	35.1	20 000	VS22/23B	Width tolerance special ¹⁾	25
	29	17	17.0	20.0	20 000	RV222917	—	23
	30	15	16.7	17.9	19 000	RV223015	—	25
	30	18	21.8	25.2	19 000	RV223018	—	30
	30	20	24.1	28.8	19 000	RV223020-1	—	31
	32	15	21.1	21.3	19 000	RV223215	—	32
	32	16	21.1	21.3	19 000	RV223216	—	35

[Note] 1) For further information, consult with JTEKT.

[Remark] Limiting speed of grease lubrication should be kept to under 60 % of that for oil lubrication.

F_W (22) ~ (25) mm

ϕE_w : Roller set outside diameter

ϕF_w : Roller set bore diameter

Boundary dimensions (mm)			Basic load ratings (kN)		Limiting speeds (min ⁻¹)	Bearing No.	Special series (Cage)	(Refer.) Mass (g)
F_w	E_w	B	C_r	C_{Or}	Oil lub.			
22	32	30	40.4	48.9	19 000	RV223230	—	62
23	29	30	26.0	39.0	19 000	23V2930	Width tolerance special ¹⁾	35
	30	15	17.4	21.0	19 000	RV233015	—	21
	33	20	27.0	29.4	18 000	23V3320-1	Width tolerance special ¹⁾	44
24	28	13	11.1	17.4	19 000	RS242813	—	12
	28	17	13.7	22.8	19 000	R24/17A	—	16
	28	23	18.2	32.9	19 000	RS242823	—	21
	32	15	20.0	23.2	18 000	RV243215-4	—	27
25	29	9.9	7.1	9.8	19 000	R25/10A	Width tolerance special ¹⁾	10
	29	13	11.5	18.4	19 000	R25/13-1	—	13
	30	9.9	9.3	12.0	18 000	25R3010A	Width tolerance special ¹⁾	13
	30	12	10.5	14.1	18 000	25R3012	—	15
	30	17	15.7	23.6	18 000	25V3017	—	18
	30	20	19.0	30.1	18 000	25R3020-1	—	24
	30	20	16.6	25.3	18 000	25VPU3020B	Double split	16
	31	17.5	17.4	23.8	18 000	VPS25/18	—	18
	31	18	17.4	23.8	18 000	RS25/18	—	27
	31	20	21.0	30.5	18 000	VS25/20	Width tolerance special ¹⁾	26
	31	24	24.9	37.8	18 000	25R3124	—	35
	32	16	18.9	23.8	18 000	25V3216	—	25
	32	24	26.4	36.7	18 000	RS253224	—	43
	32	32	37.8	58.4	18 000	RPU253232F-1	Double split	51
	32	32	39.6	62.0	18 000	RV253232	—	49
	33	20	24.1	29.8	17 000	RV253320	—	35
33	23.8	30.2	40.0	17 000	25R3324B-1	Width tolerance special ¹⁾	48	
33	30	38.6	54.8	17 000	RF253330	Polyamide	41	
35	25	32.5	38.0	17 000	25R3525	—	65	

Needle roller and cage assemblies

F_w (25) ~ 29 mm

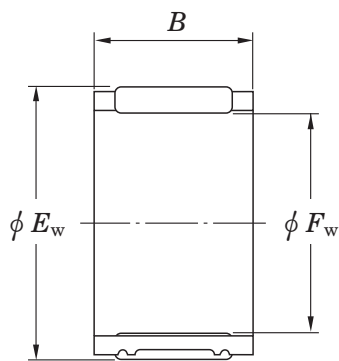

RS, R, RP

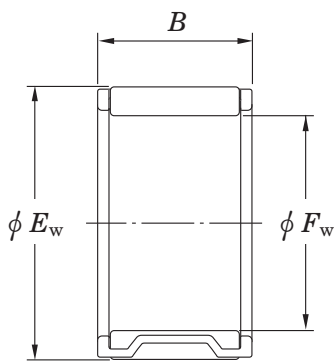

RV, V, VS

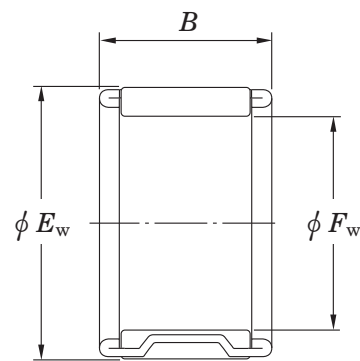

VP, VPS

Boundary dimensions (mm)			Basic load ratings (kN)		Limiting speeds (min ⁻¹)	Bearing No.	Special series (Cage)	(Refer.) Mass (g)
F_w	E_w	B	C_r	C_{0r}	Oil lub.			
25	35	30	39.6	49.0	17 000	25V3530A	—	69
	37	24	34.1	36.2	16 000	25V3724	—	69
	37	25	38.3	42.2	16 000	25V3725A	—	77
	37	33	47.5	55.7	16 000	RV253733	—	96
26	30	20	16.9	30.6	18 000	RS263020	—	20
	30	21.9	16.9	30.4	18 000	RS263022A	—	22
	31	16	15.7	23.8	18 000	RS263116	—	20
	31	19	18.5	29.5	18 000	RS263119	—	24
	33	34	30.4	44.0	17 000	RPV263334F	Double split	42
	34	17	23.9	30.0	17 000	RV263417	—	32
27	32	27	26.2	46.6	17 000	RFN27/27	Polyamide, Width tolerance special ¹⁾ Double split	20
	33	28.6	30.0	49.2	17 000	VPSU27/29AF		33
28	32	26	17.1	31.5	17 000	28R3226	—	27
	32	29	17.1	31.5	17 000	28R3229	—	32
	33	17	17.9	29.0	16 000	28R3317	—	22
	33	23	22.8	39.6	16 000	R28/23A	—	31
	33	27	25.0	44.5	16 000	R28/27	—	36
	36	20	23.2	29.3	16 000	28R3620	—	45
	38	24	31.2	37.1	15 000	RS283824	—	70
	40	28	49.1	59.5	15 000	RV284028	—	90
	41	25	40.2	43.6	14 000	RV284125	—	86
	42	50.5	88.9	116.5	14 000	RF284251A	Polyamide	182
29	34	22	17.3	27.6	16 000	R29/22A	With double split polyamide	30
	34	24.4	19.7	32.8	16 000	RFU293424A		17
	34	27	25.7	46.7	16 000	29R3427A-1		37
	43	43	73.7	92.2	14 000	RV294343		177

[Note] 1) For further information, consult with JTEKT.

[Remark] Limiting speed of grease lubrication should be kept to under 60 % of that for oil lubrication.

F_w 30 ~ (32) mm

ϕE_w : Roller set outside diameter

ϕF_w : Roller set bore diameter

Boundary dimensions (mm)			Basic load ratings (kN)		Limiting speeds (min ⁻¹)	Bearing No.	Special series (Cage)	(Refer.)
F_w	E_w	B	C_r	C_{Or}	Oil lub.			Mass (g)
30	34	14	7.7	11.4	16 000	30R3414A	—	16
	34	14	7.7	11.5	16 000	RFN303414	Polyamide	6.1
	34	29	18.1	34.8	16 000	30R3429	—	34
	34	29	20.4	40.8	16 000	RSU303429	Double split	33
	35	17	17.7	29.2	15 000	R30/17-1	—	24
	35	21.1	22.2	39.0	15 000	RS303521A	—	30
	35	24	24.9	45.1	15 000	RS303524	—	34
	37	16	21.8	30.3	15 000	RV303716	—	29
	37	20	25.2	36.6	15 000	RS30/20A	—	41
	37	26	34.7	55.3	15 000	RV303726	—	47
	38	22.1	27.7	37.5	15 000	RP303822A	Welded	45
	38	28.3	33.5	47.8	15 000	RPU303828AF	Double split	47
	39	27	34.2	45.6	14 000	RP303927	—	51
	39	30	38.3	52.8	14 000	30VP3930A	Width tolerance special ¹⁾	58
	39	32	42.6	60.5	14 000	RP303932	Welded, Width tolerance special ¹⁾	63
	40	15.5	26.7	31.1	14 000	RV304016A-4	—	46
	40	20	32.0	39.1	14 000	30V4020	—	55
	42	15	27.0	28.0	14 000	RF304215	Polyamide	36
	42	25	44.0	52.3	14 000	RV304225	—	84
	42	32	52.7	66.0	14 000	30V4232	Width tolerance special ¹⁾	108
45	30	54.4	60.2	13 000	30V4530	—	135	
31	36	20.3	19.9	34.2	15 000	RFU313620A-1	With double split polyamide	17
32	36	15	10.8	18.3	15 000	32R3615A	—	19
	37	17	19.0	32.6	14 000	R32/17-1	—	26
	37	20	22.3	39.9	14 000	R32/20	—	30
	37	23.8	22.6	40.5	14 000	RF323724A-1	With single split polyamide	20
	37	26	26.2	49.0	14 000	RF323726	Polyamide, Width tolerance special ¹⁾	24
	37	29.5	31.1	61.2	14 000	VP32/30A	—	32

Needle roller and cage assemblies

F_w (32) ~ (35) mm

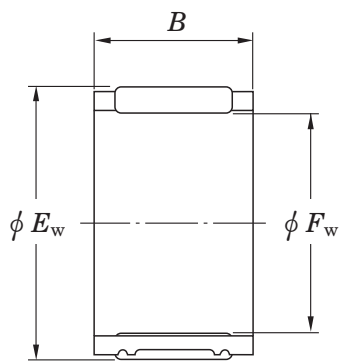

RS, R, RP

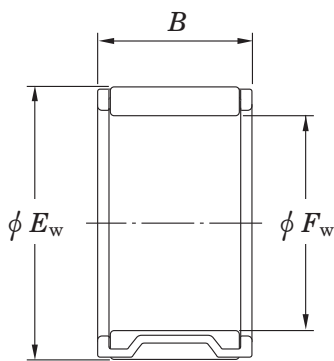

RV, V, VS

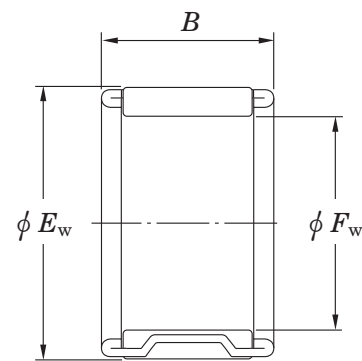

VP, VPS

Boundary dimensions (mm)			Basic load ratings (kN)		Limiting speeds (min ⁻¹)	Bearing No.	Special series (Cage)	(Refer.) Mass (g)
F_w	E_w	B	C_r	C_{0r}	Oil lub.			
32	38	20	24.9	40.6	14 000	32VP3820A	Welded	27
	38	26	27.3	45.6	14 000	RP323826	Width tolerance special ¹⁾	34
	38	27	29.6	50.7	14 000	32VP3827	Width tolerance special ¹⁾	38
	39	16	21.2	29.8	14 000	RS323916	—	35
	42	16	27.5	32.9	14 000	RV324216	—	49
	42	20.5	33.5	42.2	14 000	RV324221-1	—	64
	45	28	47.9	56.5	13 000	32V4528	—	112
	46	18	37.0	38.8	13 000	RF324618	Polyamide	57
	46	18	30.3	29.8	13 000	RV324618-1	—	71
33	37	22	18.5	37.2	14 000	RSU333722F	Double split	27
34	39	20.3	19.6	34.4	14 000	RFU343920A	With double split polyamide	18
	42	38	49.2	81.9	13 000	34R4238	Width tolerance special ¹⁾	98
	44	40	64.1	99.1	13 000	34VP4440-1	—	101
35	39	25	22.0	47.4	14 000	RF353925	With single split polyamide	24
	40	13	14.2	23.0	13 000	RS354013	—	22
	40	17	18.4	32.0	13 000	RS354017	—	29
	40	22	23.6	44.4	13 000	RS354022	—	37
	40	24	25.9	49.9	13 000	RS354024	—	39
	40	24.8	23.7	44.4	13 000	RSU354025AF	Double split	39
	40	25	27.0	52.7	13 000	RS354025-1	—	41
	40	26	28.7	56.9	13 000	RS354026	—	41
	40	28	28.7	56.9	13 000	RF354028	Polyamide	27
	40	29	30.6	61.7	13 000	RP354029-1	Width tolerance special ¹⁾	33
	40	30	30.6	61.7	13 000	VP35/30	—	34
	40	31	30.6	61.6	13 000	RP354031	Welded, Width tolerance special ¹⁾	37
	40	33	31.1	63.2	13 000	RP354033-1	—	39
	40	35	31.8	64.9	13 000	RF354035	Polyamide	32

[Note] 1) For further information, consult with JTEKT.

[Remark] Limiting speed of grease lubrication should be kept to under 60 % of that for oil lubrication.

F_W (35) ~ 37 mm

ϕE_w : Roller set outside diameter

ϕF_w : Roller set bore diameter

Boundary dimensions (mm)			Basic load ratings (kN)		Limiting speeds (min ⁻¹)	Bearing No.	Special series (Cage)	(Refer.) Mass (g)
F_w	E_w	B	C_r	C_{Or}	Oil lub.			
35	41	35	40.4	78.0	13 000	35VP4135A	—	51
	41	40	42.4	82.6	13 000	35VP4140A	—	59
	42	20	27.2	42.0	13 000	VS35/20	—	42
	42	30	39.9	68.8	13 000	VS35/30	Width tolerance special ¹⁾	59
	48	17.5	37.8	42.7	12 000	RV354818A-4	—	81
	49	25	53.4	63.4	12 000	RV354925-1	—	120
36	40	10	9.6	16.5	13 000	36R4010	—	14
	41	20	21.7	40.3	13 000	RS364120	—	34
	41	25	29.9	60.6	13 000	36RFN4125A	Polyamide	27
	41	30.5	33.1	69.2	13 000	R36/31	—	51
	42	17	20.5	32.8	13 000	RS364217-K	—	35
	42	19	23.2	38.6	13 000	RS364219-K	—	39
	42	21	25.9	44.4	13 000	RS364221-K	—	44
	42	25	33.1	60.9	13 000	RF364225-1	Polyamide	34
	48	25	54.0	71.7	12 000	RF364825-1	Polyamide	80
	52	30	73.9	89.9	11 000	RF365230	Polyamide	139
37	42	11.6	11.3	17.5	13 000	RS374212A	—	23
	42	12.8	14.0	23.2	13 000	VP37/13A	Width tolerance special ¹⁾	14
	42	17.3	21.3	39.7	13 000	VP37/17	Width tolerance special ¹⁾	21
	42	22	24.0	46.3	13 000	37R4222	—	38
	42	23	23.8	45.5	13 000	RF374223-1	With single split polyamide	22
	42	27	30.8	63.6	13 000	RS374227	—	46
	42	27	30.0	61.5	13 000	RSU374227	Double split	45
	42	29	31.9	66.5	13 000	VP37/29	—	35
	42	31	33.9	72.1	13 000	RS374231	Welded	52
	42	32	31.2	64.3	13 000	VP37/32	—	37
	43	32	39.1	75.8	13 000	37R4332	—	66
	43	36.8	40.0	77.9	13 000	RPU374337F	Double split	60

Needle roller and cage assemblies

F_w 38 ~ 41 mm

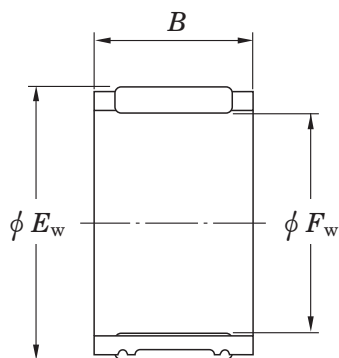

RS, R, RP

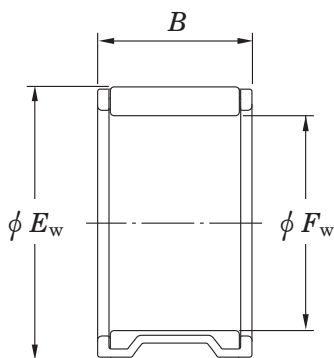

RV, V, VS

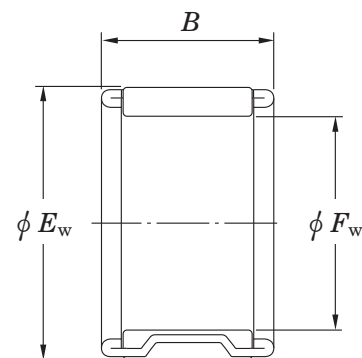

VP, VPS

Boundary dimensions (mm)			Basic load ratings (kN)		Limiting speeds (min ⁻¹)	Bearing No.	Special series (Cage)	(Refer.) Mass (g)
F_w	E_w	B	C_r	C_{0r}	Oil lub.			
38	42	10	8.9	15.2	13 000	RF384210	Polyamide	6.6
	44	23.4	25.1	43.1	12 000	RF384423A	Polyamide	26
	44	24.5	27.5	48.4	12 000	RSU384425AF	Double split	51
	44	26	28.7	51.1	12 000	RF384426	Polyamide	29
	44	33	37.9	73.4	12 000	RP384433	—	64
	44	36.2	39.9	78.1	12 000	RP384436A	—	57
	44	39.8	43.7	88.1	12 000	RP384440A	—	65
	52	39	74.8	99.2	11 000	RP385239	—	155
39	46	32.8	42.4	76.9	12 000	39R4633	—	82
	55	20.5	55.0	62.6	11 000	RF395521A	Polyamide	98
	59	23	63.8	66.3	10 000	RV395923-1	—	196
40	45	13	17.1	30.8	12 000	RV404513	—	22
	45	17	19.9	37.4	12 000	R40/17-1	—	32
	45	21.2	23.6	46.6	12 000	RS404521A	—	40
	45	27	29.9	63.0	12 000	RS404527	—	49
	45	30	30.5	64.4	12 000	R40/30	—	55
	45	32	14.3	23.3	12 000	R40/32A	—	53
	46	14.5	21.2	35.5	12 000	RP404615A	Welded	31
	46	29	36.4	70.6	12 000	RS404629	—	65
	47	20	27.6	44.8	11 000	RS40/20	—	54
	47	28.5	38.0	67.6	11 000	RS40/29A	—	77
	48	34	50.4	88.3	11 000	40V4834	—	87
	55	27.5	68.0	85.6	11 000	RF405528A-1	Polyamide	124
	56	20	50.8	56.7	10 000	RV405620-4	—	122
	57	31.5	83.4	103	10 000	RF405732A	Polyamide	168
	60	31.5	94.1	110	10 000	RF406032A	Polyamide	214
41	46	24	11.0	16.8	11 000	41R4624A	—	44

[Note] 1) For further information, consult with JTEKT.

[Remark] Limiting speed of grease lubrication should be kept to under 60 % of that for oil lubrication.

F_W 42 ~ (45) mm

ϕE_w : Roller set outside diameter

ϕF_w : Roller set bore diameter

Boundary dimensions (mm)			Basic load ratings (kN)		Limiting speeds (min ⁻¹)	Bearing No.	Special series (Cage)	(Refer.) Mass (g)
F_w	E_w	B	C_r	C_{Or}	Oil lub.			
42	47	10	13.9	23.8	11 000	RS424710-1	Welded	21
	47	25	29.5	63.1	11 000	RS424725	—	52
	47	27	32.3	70.8	11 000	RS424727	—	51
	47	30	31.9	69.8	11 000	RSU424730	Double split	58
	47	30	36.3	82.4	11 000	VP42/30	—	44
	49	22	29.3	49.0	11 000	RF424922	Polyamide	35
43	48	18	21.9	43.2	11 000	RS434818	—	36
	48	18.5	22.1	43.7	11 000	RS434819A-2	—	38
	48	21.2	25.0	51.5	11 000	RS434821A	—	46
	48	23.3	29.4	63.2	11 000	RS434823A	—	46
	48	24.4	28.2	59.9	11 000	RS434824A	—	49
	48	30	34.1	76.5	11 000	RS434830	Welded	58
	49	31	40.1	82.5	11 000	43VP4931E	—	55
	52	39.9	65.2	116	11 000	43VP5240	—	114
44	50	27.5	36.0	72.2	11 000	44RFN5028	Polyamide	39
	50	39	46.4	100	11 000	RP445039	—	71
45	50	13	16.0	29.4	11 000	R45/13	—	28
	50	17	22.7	46.1	11 000	RS455017	—	35
	50	19	24.1	49.7	11 000	R45/19	—	39
	50	20.2	24.1	49.6	11 000	RS455020A	—	46
	50	24	29.3	63.9	11 000	RS455024	—	50
	50	26	31.8	70.9	11 000	R45/26	—	54
	50	33	37.3	87.0	11 000	RS455033-1	—	69
	51	28.6	34.1	67.7	10 000	45RFN5129	Polyamide	40
	51	28.9	37.5	76.9	10 000	RP455129A	Welded	65
	51	28.9	37.5	76.9	10 000	RPU455129AF	Double split	67
	52	22	35.4	63.9	10 000	RS455222	—	66

Needle roller and cage assemblies

F_w (45) ~ (50) mm

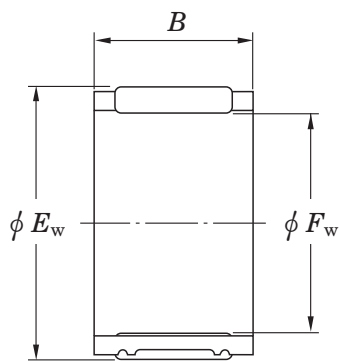

RS, R, RP

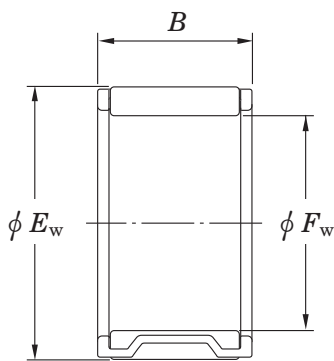

RV, V, VS

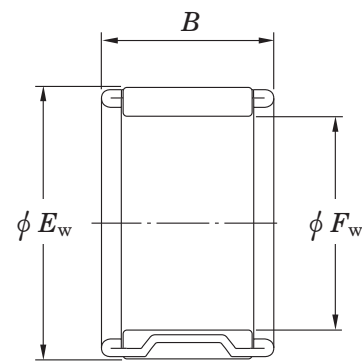

VP, VPS

Boundary dimensions (mm)			Basic load ratings (kN)		Limiting speeds (min ⁻¹)	Bearing No.	Special series (Cage)	(Refer.) Mass (g)
F_w	E_w	B	C_r	C_{0r}	Oil lub.			
45	53	25	41.4	71.1	10 000	RV455325P	—	73
	53	26	41.4	71.1	10 000	45V5326P	—	77
	53	28	42.3	73.2	10 000	45VP5328	Width tolerance special ¹⁾	66
	64	23	64.0	70.4	9 200	RV456423-7	—	191
46	52	20	25.9	48.2	10 000	46VP5220	—	34
	52	37	45.8	100	10 000	46VP5237B	—	67
47	52	30	36.4	85.4	10 000	R47/30H	—	62
	52	30	35.1	81.7	10 000	RSU475230F-1	Double split	62
	53	28.8	35.3	72.3	10 000	RP475329A	—	55
	53	30	42.6	92.1	10 000	RP475330-1	Welded	74
	53	36	47.0	104	10 000	RP475336	—	68
48	53	13	16.1	30.1	9 900	RS485313	—	30
	53	28	34.1	79.2	9 900	48R5328	—	60
	54	20	29.3	57.3	9 800	48R5420-1	—	54
	54	27	38.1	80.4	9 800	48R5427	—	72
	54	28	37.8	79.3	9 800	RS485428	Welded	72
	54	29	39.5	84.3	9 800	48R5429	—	78
	54	30.2	43.8	96.2	9 800	RP485430A-1	Welded	72
	54	39	47.9	108	9 800	48R5439	—	106
	55	21	32.4	58.1	9 700	RP485521	Welded	60
49	56	44.6	61.2	133	9 500	RP495645A	Welded	120
	56	44.6	61.2	133	9 500	RS495645A	—	146
50	55	17.5	22.3	46.5	9 500	RS505518A	Welded	39
	55	20	25.1	54.3	9 500	RS505520-1	—	47
	55	27	11.5	18.9	9 500	R50/27A	—	56
	56	13	16.7	28.2	9 400	RF505613	Polyamide	18

[Note] 1) For further information, consult with JTEKT.

[Remark] Limiting speed of grease lubrication should be kept to under 60 % of that for oil lubrication.

F_W (50) ~ (58) mm

ϕE_w : Roller set outside diameter

ϕF_w : Roller set bore diameter

Boundary dimensions (mm)			Basic load ratings (kN)		Limiting speeds (min ⁻¹)	Bearing No.	Special series (Cage)	(Refer.) Mass (g)
F_w	E_w	B	C_r	C_{Or}	Oil lub.			
50	56	28	39.5	85.5	9 400	RP505628	Welded	69
	56	30	41.0	89.6	9 400	RF505630	Polyamide	50
	57	33.5	47.8	97.1	9 300	RP505734A	—	79
	57	38.9	58.3	126	9 300	RS505739A	—	133
	57	40.8	60.9	133	9 300	RS505741A	—	127
	58	25	38.5	66.9	9 300	RF505825	Polyamide	53
	70	36	114	147	8 300	RF507036	Polyamide	277
51	56	28	34.8	83.0	9 300	VP51/28	—	45
52	72	32	108	138	8 100	RF527232	Polyamide	259
53	58	25	32.2	76.0	9 000	RF535825	Polyamide	35
54	60	31.1	45.3	104	8 800	RP546031A	Welded	83
	60	36	45.5	105	8 800	RP546036	Welded, Width tolerance special ¹⁾	82
	61	34.7	60.2	135	8 700	RPU546135AF	Double split	116
	61	41.3	63.3	143	8 700	RS546141A	—	145
55	59	13	10.8	21.9	8 800	55RFN5913A	Polyamide	11
	60	20	26.7	60.6	8 700	R55/20	—	52
	60	28	35.8	88.4	8 700	RS556028	—	69
56	60	20	24.0	62.4	8 600	RF566020	Polyamide	23
	61	11	13.6	25.6	8 500	RF566111	Polyamide	14
	61	30	39.7	102	8 500	RS566130	Welded	75
	61	33.5	42.5	111	8 500	R56/34	—	85
58	65	26	42.1	87.1	8 100	58R6526	Width tolerance special ¹⁾	99
	65	36.6	55.7	125	8 100	58RFN6537A	Polyamide	80
	65	36.6	56.4	127	8 100	RS586537A-2	—	145

Needle roller and cage assemblies

F_w (58) ~ 78 mm

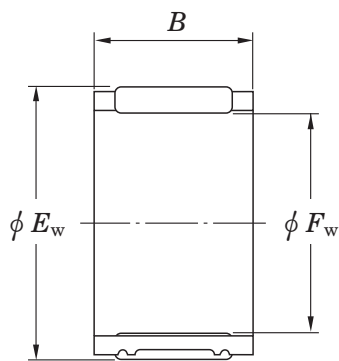

RS, R, RP

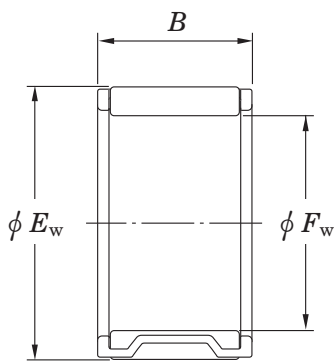

RV, V, VS

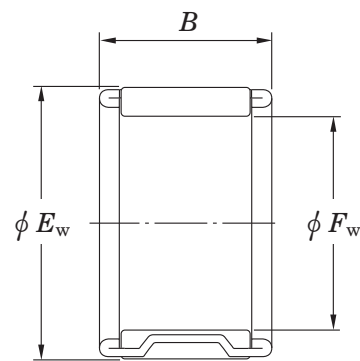

VP, VPS

Boundary dimensions (mm)			Basic load ratings (kN)		Limiting speeds (min ⁻¹)	Bearing No.	Special series (Cage)	(Refer.) Mass (g)
F_w	E_w	B	C_r	C_{0r}	Oil lub.			
58	65	37.5	57.7	131	8 100	RP586538A RV588072	Welded, Width tolerance special ¹⁾ —	108 889
	80	72	233	359	7 200			
60	65	30	40.0	105	8 000	R60/30	—	81
	66	19	31.5	67.8	7 900	RS606619	—	63
	67	23	40.1	82.8	7 900	60V6723	—	77
	82	30	118	152	7 000	RF608230	Polyamide	316
63	68	30	40.9	110	7 600	R63/30	—	83
64	70	24.5	39.4	92.4	7 500	64R7025A 64R7035	—	86
	70	35	55.7	144	7 500		—	122
65	70	20	12.1	22.3	7 400	R65/20A R65/24A	—	57
	70	24	12.5	22.9	7 400		—	67
70	76	20	34.7	80.8	6 800	70R7620 RP707632 70R7830	—	77
	76	32	55.1	147	6 800		Welded	116
	78	30	59.4	132	6 800		—	154
71	79	30.15	61.3	138	6 700	71V7930B RS717940AZ	—	135
	79	39.5	75.3	179	6 700		—	203
72	79	21	39.6	86.6	6 600	72V7921	—	84
73	79	20	36.3	86.8	6 600	R73/20	—	84
78	85	33.75	62.3	159	6 100	78R8534A	—	168

[Note] 1) For further information, consult with JTEKT.

[Remark] Limiting speed of grease lubrication should be kept to under 60 % of that for oil lubrication.

ϕE_w : Roller set outside diameter

ϕF_w : Roller set bore diameter

Drawn cup needle roller bearings

F_w 4 ~ (12) mm

Caged type

With open ends

With closed end

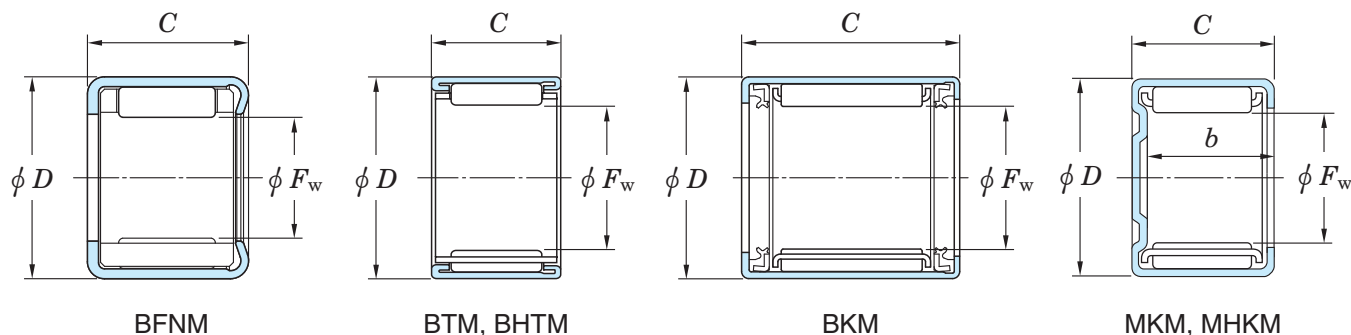

Boundary dimensions (mm)				Basic load ratings (kN)		Limiting speeds (min ⁻¹)	Bearing No. ²⁾	
F_w	D	C	b min.	C_r	C_{0r}	Oil lub.	With open ends	With closed end
4	8	8	—	1.60	1.25	47 000	4BFNM88	—
5	9	9	—	2.40	2.15	44 000	5BFNM99	—
6	10	9	6	2.40	2.40	42 000	6BTM109	—
7	11	9	—	2.55	2.70	39 000	7BTM119	—
8	12	10	8.4	3.25	3.85	37 000	8BTM1210	8MKM1210
	12	10	7.8	4.95	7.50	13 000	—	—
	12	10	—	5.25	8.60	13 000	—	—
	15	10	8.4	4.00	3.30	34 000	BHTM810	MHKM810
	15	15	—	7.45	6.50	34 000	BHTM815	—
	15	20	17.3	9.25	9.70	34 000	BHTM820	MHKM820
9	13	10	7.8	4.90	8.05	12 000	—	—
	13	10	8.4	3.35	4.10	35 000	9BTM1310A	9MKM1310
	13	12	10.4	4.20	5.50	35 000	9BTM1312	9MKM1312
	16	12	10.4	5.35	5.05	32 000	BHTM912-1	MHKM912
	16	16	13.3	7.55	7.90	32 000	BHTM916	MHKM916
10	14	10	7.8	5.70	9.35	11 000	—	—
	14	10	8.4	3.55	4.55	33 000	10BTM1410	10MKM1410
	14	12	10.4	4.40	6.00	33 000	10BTM1412	10MKM1412
	14	15	11.8	5.65	8.25	33 000	BTM101415	—
	17	10	8.4	4.65	4.25	30 000	BHTM1010	MHKM1010
	17	12	10.4	6.00	5.90	30 000	BHTM1012-1	MHKM1012
	17	15	—	7.85	8.45	30 000	BHTM1015	—
	17	20	17.3	10.7	12.5	30 000	BHTM1020	MHKM1020
12	16	10	8.4	4.00	5.60	29 000	12BTM1610	12MKM1610

- [Notes] 1) The limiting speeds shown above are applicable when oil seal is used and the bearing is lubricated with grease.
 2) FN in bearing number indicates a bearing comprising polyamide molded cage.
 3) The recommended dimensional tolerances of shaft shown above are applicable except h6.
 4) The recommended dimensional tolerances of housing bore shown above are applicable except N7.

Full complement type

With open ends

With closed end

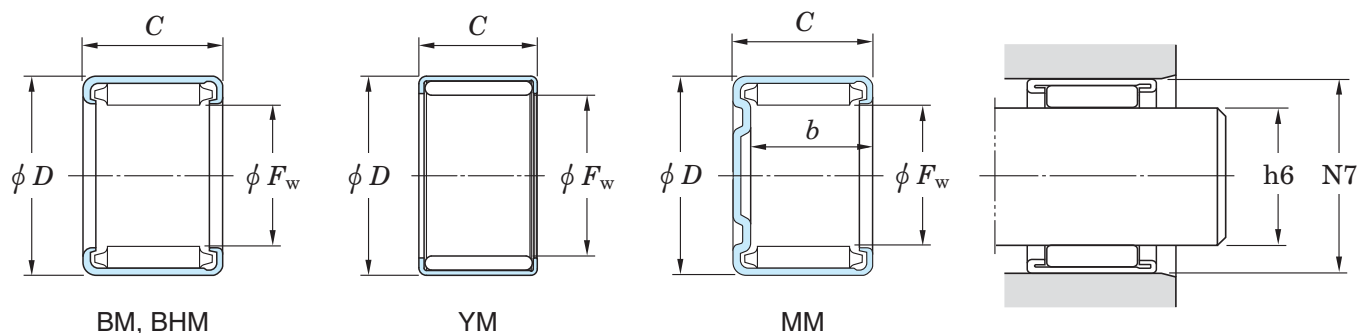

Full complement type		Recommended dimensions (mm)				(Refer.) Mass (g)	
		Shaft dia. (h6)		Housing bore dia. (N7)		With open ends	With closed end
With open ends	With closed end	min.	max.	min.	max.		
—	—	3.992	4.000	7.981	7.996	1.3	—
—	—	4.992	5.000	8.981	8.996	1.8	—
—	—	5.992	6.000	9.981	9.996	2.5	—
—	—	6.991	7.000	10.977	10.995	2.9	—
— BM081210 YM081210 — — —	— 8MM1210 — — — —	7.991	8.000	11.977	11.995	3.6	4.1
		7.991	8.000	11.977	11.995	3.7	4.2
		7.991	8.000	11.977	11.995	4.0	—
		7.991	8.000	14.977	14.995	6.5	7.3
		7.991	8.000	14.977	14.995	9.4	—
		7.991	8.000	14.977	14.995	13	14
9BM1310 — — — — —	9MM1310 — — — — —	8.991	9.000	12.977	12.995	4.0	4.6
		8.991	9.000	12.977	12.995	3.8	4.3
		8.991	9.000	12.977	12.995	4.6	5.2
		8.991	9.000	15.977	15.995	8.8	9.9
		8.991	9.000	15.977	15.995	12	13
		—	—	—	—	—	—
10BM1410 — — — — — — — —	10MM1410 — — — — — — — —	9.991	10.000	13.977	13.995	4.2	4.8
		9.991	10.000	13.977	13.995	4.2	4.8
		9.991	10.000	13.977	13.995	5.0	5.7
		9.991	10.000	13.977	13.995	6.4	—
		9.991	10.000	16.977	16.995	7.8	8.9
		9.991	10.000	16.977	16.995	9.4	11
		9.991	10.000	16.977	16.995	12	—
		9.991	10.000	16.977	16.995	16	18
		—	—	—	—	—	—
—	—	11.989	12.000	15.977	15.995	5.0	5.6

[Remark] Limiting speed of grease lubrication should be kept to under 60 % of that for oil lubrication.

Drawn cup needle roller bearings

F_w (12) ~ 14.50 mm

Caged type

With open ends

With closed end

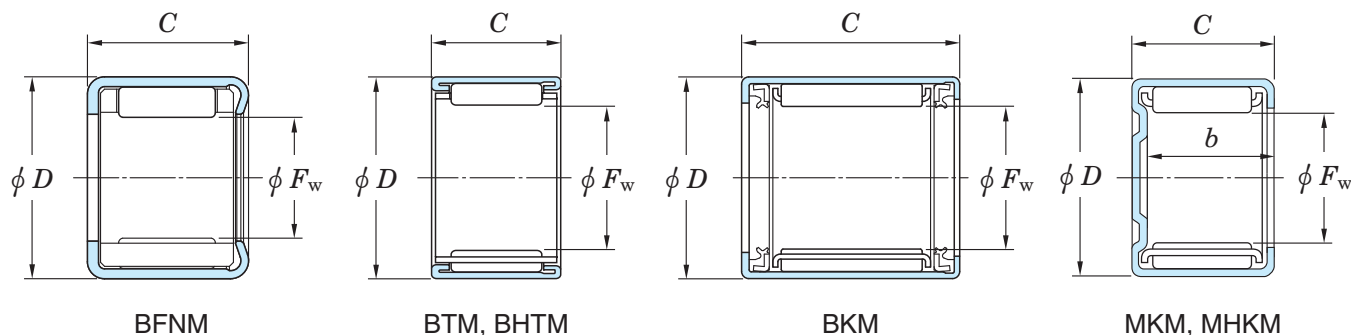

Boundary dimensions (mm)				Basic load ratings (kN)		Limiting speeds (min ⁻¹)	Bearing No. ²⁾	
F_w	D	C	b min.	C_r	C_{0r}	Oil lub.	With open ends	With closed end
12	18	10	8.4	4.60	4.80	27 000	12BTM1810	12MKM1810
	18	12	9.6	8.40	12.6	9 400	—	—
	18	12	9.3	5.95	6.70	27 000	12BTM1812	12MKM1812
	18	15	—	6.10	7.32	27 000	12BTM1815A	—
	18	16	—	5.65	6.25	16 000 ¹⁾	12BKM1816UU	—
	19	12	9.3	6.70	6.95	26 000	BHTM1212-1	MHKM1212
	19	15	—	8.85	9.95	26 000	BHTM1215-1	MKM121915
	19	20	17.3	12.1	14.9	26 000	BHTM1220	MHKM1220
19	25	—	15.0	19.6	26 000	BHTM1225	—	
13	17	15	—	5.10	7.85	27 000	BKM131715J	—
	19	12	—	8.55	13.4	9 100	—	—
	19	12	9.3	5.85	6.70	26 000	13BTM1912	13MKM1912
	19	14	—	7.65	9.60	26 000	BKM131914J	—
	20	12	—	7.50	8.40	25 000	13BTM2012J	—
	21	14	—	9.75	10.5	25 000	BKM132114BJ	—
13.50	19	12	—	6.25	7.95	25 000	BTM141912A	—
14	19	16	13.7	11.7	23.3	8 800	—	—
	19	16	13.3	7.85	11.7	25 000	14BTM1916B	14MKM1916
	20	12	9.6	9.15	14.6	8 600	—	—
	20	12	9.3	6.10	7.20	25 000	14BTM2012	14MKM2012
	20	16	13.7	12.7	22.4	8 600	—	—
	20	16	13.3	8.75	11.4	25 000	14BTM2016	14MKM2016
	20	25	—	12.2	15.5	14 000 ¹⁾	14BKM2025JUJ	—
	22	16	13.3	11.1	12.6	23 000	BHTM1416	MHKM1416
	22	20	17.3	14.4	17.5	23 000	BHTM1420	MHKM1420
14.50	19.50	13.50	—	7.55	10.9	25 000	BTM152014A	—

- [Notes] 1) The limiting speeds shown above are applicable when oil seal is used and the bearing is lubricated with grease.
 2) FN in bearing number indicates a bearing comprising polyamide molded cage.
 3) The recommended dimensional tolerances of shaft shown above are applicable except h6.
 4) The recommended dimensional tolerances of housing bore shown above are applicable except N7.

Full complement type

With open ends

With closed end

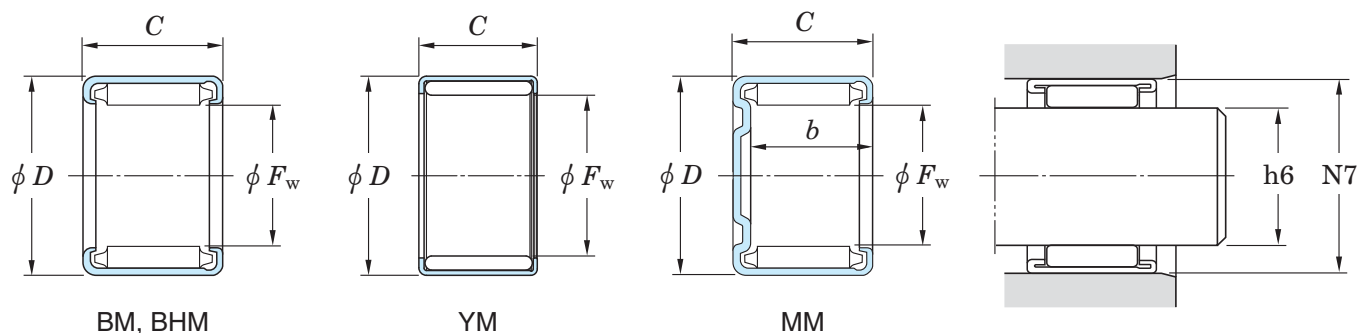

Full complement type With open ends With closed end		Recommended dimensions (mm)				(Refer.) Mass (g)	
		Shaft dia. (h6)		Housing bore dia. (N7)		With open ends	With closed end
		min.	max.	min.	max.		
— 12BM1812 — — — — — —	—	11.989	12.000	17.977	17.995	7.2	8.2
	12MM1812	11.989	12.000	17.977	17.995	9.7	11
	—	11.989	12.000	17.977	17.995	7.6	8.5
	—	11.989	12.000	17.991 ⁴⁾	18.012 ⁴⁾	12	—
	—	11.989	12.000	17.977	17.995	11	—
	—	11.989	12.000	18.972	18.993	10	12
	—	11.989	12.000	18.972	18.993	13	—
	—	11.989	12.000	18.972	18.993	17	19
13BM1912 — — — —	—	12.989	12.000	16.977	16.995	7.1	—
	—	12.989	13.000	18.972	18.993	10	—
	—	12.989	13.000	18.972	18.993	9.5	11
	—	12.989	13.000	18.972	18.993	11	—
	—	12.989	13.000	19.972	19.993	11	—
	—	12.989	13.000	20.972	20.993	15	—
—	—	13.447 ³⁾	13.460 ³⁾	19.000 ⁴⁾	19.021 ⁴⁾	9.5	—
14BM1916 — 14BM2012 — 14BM2016 — — — —	14MM1916	13.989	14.000	18.972	18.993	12	14
	—	13.983 ³⁾	13.994 ³⁾	18.972	18.993	11	12
	14MM2012	13.989	14.000	19.972	19.993	11	12
	—	13.989	14.000	19.972	19.993	9.8	11
	14MM2016	13.989	14.000	19.972	19.993	15	17
	—	13.989	14.000	19.972	19.993	13	15
	—	13.989	14.000	19.972	19.993	20	—
	—	13.989	14.000	21.972	21.993	19	21
	—	13.989	14.000	21.972	21.993	23	26
—	—	14.489	14.500	19.472	19.493	9.5	—

[Remark] Limiting speed of grease lubrication should be kept to under 60 % of that for oil lubrication.

Drawn cup needle roller bearings

F_w 15 ~ (17) mm

Caged type

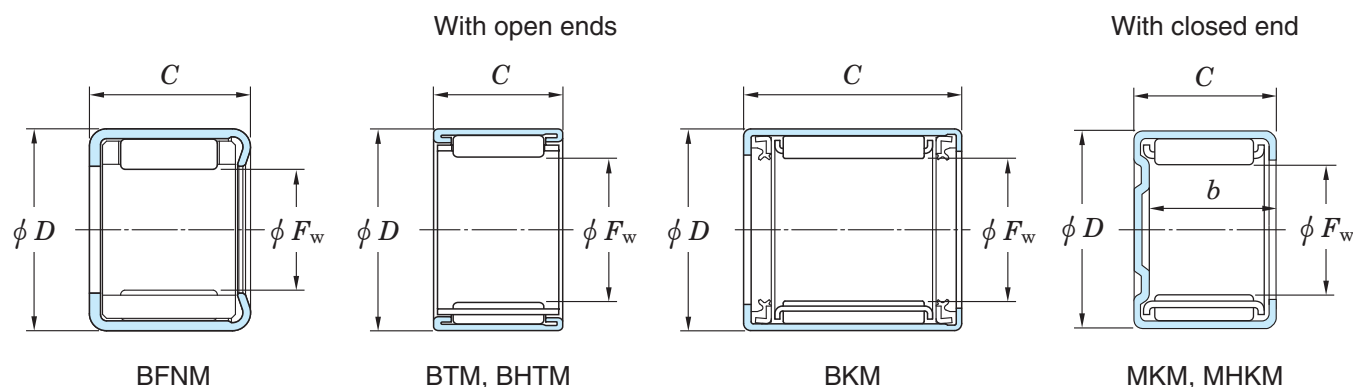

Boundary dimensions (mm)				Basic load ratings (kN)		Limiting speeds (min ⁻¹)	Bearing No. ²⁾	
F_w	D	C	b min.	C_r	C_{0r}	Oil lub.	With open ends	With closed end
15	20	16	—	8.15	12.6	24 000	15BTM2016C-2	—
	21	10	—	7.70	11.8	8 100	—	—
	21	10	—	5.25	6.25	23 000	15BTM2110JA	—
	21	12	9.6	9.70	15.9	8 100	—	—
	21	12	9.3	7.00	8.80	23 000	15BTM2112-1	15MKM2112
	21	16	13.7	13.4	24.2	8 100	—	—
	21	16	13.3	9.80	13.6	23 000	15BTM2116	15MKM2116
	21	22	—	13.0	19.5	23 000	15BTM2122	—
	22	10	8.4	6.15	6.45	23 000	BHTM1510	MHKM1510
	22	12	9.3	6.90	7.95	23 000	BHTM1512A	MHKM1512
	22	15	—	10.9	13.3	23 000	BHTM1515-1	—
	22	20	17.3	14.2	18.8	23 000	BHTM1520	MHKM1520
	22	25	—	17.7	25.0	23 000	BHTM1525	—
16	22	12	9.6	10.2	17.1	7 700	—	—
	22	12	9.3	7.60	9.80	22 000	16BTM2212A	16MKM2212
	22	16	13.7	14.1	25.9	7 700	—	—
	22	16	13.3	10.7	15.1	22 000	16BTM2216	16MKM2216
	22	22	—	16.2	22.9	22 000	16BTM2222B	—
	24	12	—	8.00	8.45	21 000	BHTM1612	—
	24	16	13.3	12.2	14.9	21 000	BHTM1616A	MHKM1616
	24.15	14	12.6	8.45	9.05	12 000 ¹⁾	—	MKM162414U
17	21.50	15	10.6	6.15	9.60	22 000	17BTM2215	—
	22	10	—	5.05	6.90	21 000	BTM1710	—
	22	13	—	10.6	21.6	7 500	—	—
	23	12	9.6	10.3	17.9	7 300	—	—
	23	12	—	7.65	10.2	21 000	BTM172312	—
	23	20	—	18.0	36.7	7 300	—	—

- [Notes] 1) The limiting speeds shown above are applicable when oil seal is used and the bearing is lubricated with grease.
 2) FN in bearing number indicates a bearing comprising polyamide molded cage.
 3) The recommended dimensional tolerances of shaft shown above are applicable except h6.
 4) The recommended dimensional tolerances of housing bore shown above are applicable except N7.

Full complement type

With open ends

With closed end

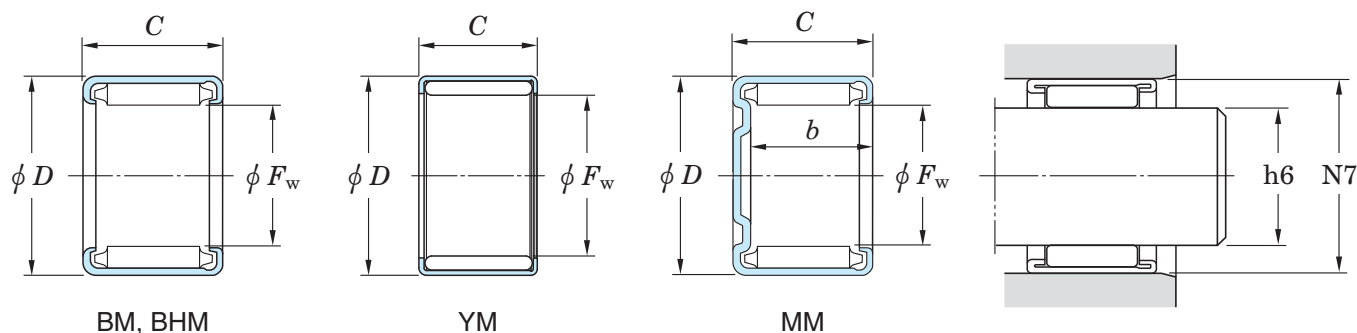

Full complement type		Recommended dimensions (mm)				(Refer.) Mass (g)	
		Shaft dia. (h6)		Housing bore dia. (N7)		With open ends	With closed end
With open ends	With closed end	min.	max.	min.	max.		
—	—	14.989	15.000	19.991 ⁴⁾	20.012 ⁴⁾	12	—
15BM2110	—	14.989	15.000	20.972	20.993	9.4	—
—	—	14.989	15.000	20.991 ⁴⁾	21.012 ⁴⁾	9.5	—
15BM2112	15MM2112	14.989	15.000	20.972	20.993	12	13
—	—	14.989	15.000	20.972	20.993	11	12
15BM2116	15MM2116	14.989	15.000	20.972	20.993	16	18
—	—	14.989	15.000	20.972	20.993	14	16
—	—	14.989	15.000	20.991 ⁴⁾	21.012 ⁴⁾	20	—
—	—	14.989	15.000	21.972	21.993	9.9	11
—	—	14.989	15.000	21.991 ⁴⁾	22.012 ⁴⁾	12	14
—	—	14.989	15.000	21.972	21.993	10	—
—	—	14.989	15.000	21.972	21.993	20	23
—	—	14.989	15.000	21.972	21.993	26	—
16BM2212	16MM2212	15.989	16.000	21.972	21.993	12	14
—	—	15.989	16.000	21.991 ⁴⁾	22.012 ⁴⁾	11	12
16BM2216	16MM2216	15.989	16.000	21.972	21.993	17	19
—	—	15.989	16.000	21.972	21.993	15	17
—	—	15.989	16.000	21.991 ⁴⁾	22.012 ⁴⁾	20	—
—	—	15.989	16.000	23.972	23.993	15	—
—	—	15.989	16.000	23.991 ⁴⁾	24.012 ⁴⁾	20	23
—	—	15.989	16.000	24.122	24.143	—	19
—	—	16.989	17.000	21.472	21.493	10	—
—	—	16.989	17.000	21.972	21.993	8.2	—
BM1713-1	—	16.989	17.000	21.972	21.993	12	—
17BM2312	17MM2312	16.989	17.000	22.972	22.993	13	15
—	—	16.989	17.000	22.972	22.993	12	—
17BM2320	—	16.989	17.000	22.972	22.993	23	—

[Remark] Limiting speed of grease lubrication should be kept to under 60 % of that for oil lubrication.

Drawn cup needle roller bearings

F_w (17) ~ 19 mm

Caged type

With open ends

With closed end

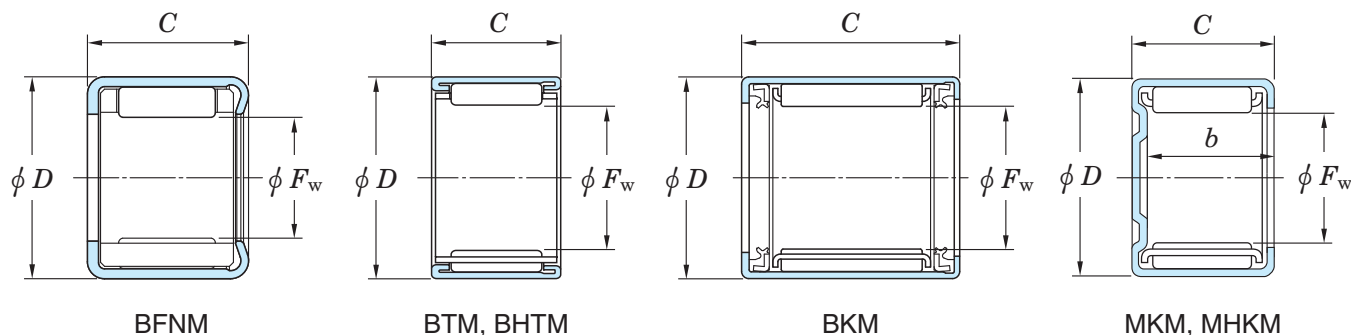

Boundary dimensions (mm)				Basic load ratings (kN)		Limiting speeds (min ⁻¹)	Bearing No. ²⁾	
F_w	D	C	b min.	C_r	C_{0r}	Oil lub.	With open ends	With closed end
17	24	12	—	12.8	21.0	7 200	—	—
	24	15	—	11.2	14.8	20 000	BHTM1715-1	—
	24	17	—	16.0	27.9	7 200	—	—
	24	20	—	12.9	17.6	11 000 ¹⁾	BHKM1720JBU	—
	24	20	—	19.0	21.9	7 200	—	—
	24	20	17.3	15.1	21.6	20 000	BHTM1720-1	MHKM1720
	24	25	—	23.8	46.6	7 200	—	—
	24	25	—	19.0	29.0	20 000	BTM172425	—
	24	26	—	16.0	23.3	11 000 ¹⁾	BHKM1726JUU	—
	24	30	—	20.1	31.3	11 000 ¹⁾	BHKM1730JU	—
	25	14	—	7.30	7.90	11 000 ¹⁾	BKM172514UH-1	—
	25	15	—	10.9	13.1	20 000	BKM172515	—
	25	16.70	—	7.30	7.90	11 000 ¹⁾	17BKM2517JBUUH	—
	25	18	—	10.9	13.1	11 000 ¹⁾	BKM172518UH	—
	25	20	—	12.9	16.3	11 000 ¹⁾	BKM172520UH-1	—
18	24	12	9.6	10.8	19.2	6 900	—	—
	24	12	—	7.90	10.9	20 000	18BTM2412	—
	24	16	13.7	16.5	29.1	6 900	—	—
	24	16	—	17.2	30.7	6 900	—	—
	24	16	—	11.1	16.8	20 000	BTM182416	—
	25	13	—	9.40	11.8	19 000	BTM1813	—
	25	15	—	10.4	9.25	19 000	BTM1815	—
	25	17	—	12.2	17.7	19 000	BTM1817A	—
	25	19	—	14.4	20.5	19 000	BTM1819	—
	25	20	17.3	15.2	22.1	19 000	BTM182520	MKM1820
	25	25	—	18.9	29.2	19 000	BTM1825A	—
	19	27	20	—	17.0	23.4	18 000	BHTM1920

- [Notes] 1) The limiting speeds shown above are applicable when oil seal is used and the bearing is lubricated with grease.
 2) FN in bearing number indicates a bearing comprising polyamide molded cage.
 3) The recommended dimensional tolerances of shaft shown above are applicable except h6.
 4) The recommended dimensional tolerances of housing bore shown above are applicable except N7.

Full complement type

With open ends

With closed end

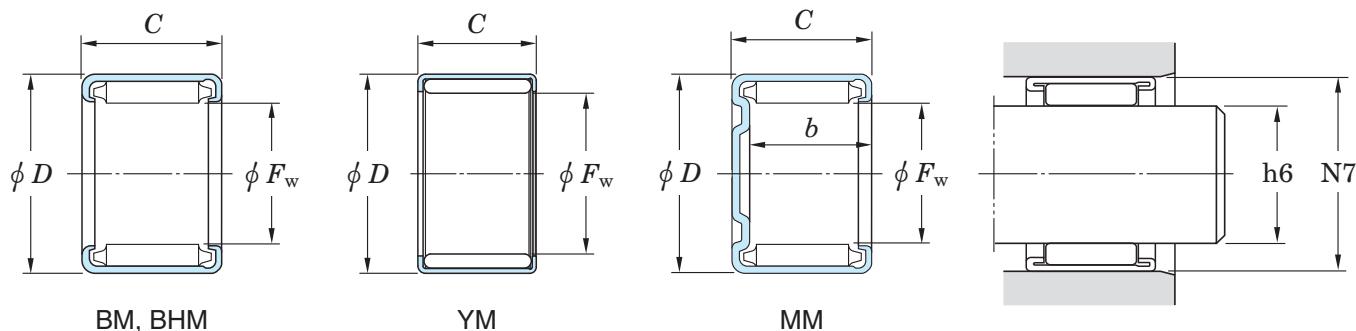

Full complement type		Recommended dimensions (mm)				(Refer.) Mass (g)	
		Shaft dia. (h6)		Housing bore dia. (N7)		With open ends	With closed end
With open ends	With closed end	min.	max.	min.	max.		
YM172412-1	—	16.983 ³⁾	16.994 ³⁾	23.985 ⁴⁾	24.006 ⁴⁾	17	—
—	—	16.989	17.000	23.972	23.993	17	—
BM172417-1	—	16.989	17.000	23.991 ⁴⁾	24.012 ⁴⁾	23	—
—	—	16.989	17.000	23.972	23.993	22	—
BHM1720A	—	16.983 ³⁾	16.994 ³⁾	23.985 ⁴⁾	24.006 ⁴⁾	27	—
—	—	16.989	17.000	23.972	23.993	24	27
BHM1725	—	16.989	17.000	23.991 ⁴⁾	24.012 ⁴⁾	35	—
—	—	16.983 ³⁾	16.994 ³⁾	23.972	23.993	22	—
—	—	16.999	17.000	23.972	23.993	29	—
—	—	16.989	17.000	23.972	23.993	35	—
—	—	16.989	17.000	24.991 ⁴⁾	25.012 ⁴⁾	18	—
—	—	16.989	17.000	24.991 ⁴⁾	25.012 ⁴⁾	20	—
—	—	16.989	17.000	24.972	24.993	20	—
—	—	16.989	17.000	24.991 ⁴⁾	25.012 ⁴⁾	24	—
—	—	16.989	17.000	24.991 ⁴⁾	25.012 ⁴⁾	27	—
18BM2412	18MM2412	17.989	18.000	23.972	23.993	17	20
—	—	17.989	18.000	23.991 ⁴⁾	24.012 ⁴⁾	12	—
18BM2416	18MM2416	17.989	18.000	23.972	23.993	18	21
18YM2416	—	17.989	18.000	23.972	23.993	19	—
—	—	17.989	18.000	23.972	23.993	17	—
—	—	17.989	18.000	24.972	24.993	15	—
—	—	17.989	18.000	24.972	24.993	18	—
—	—	17.989	18.000	24.991 ⁴⁾	25.012 ⁴⁾	20	—
—	—	17.989	18.000	24.972	24.993	22	—
—	—	17.989	18.000	24.972	24.993	24	27
—	—	17.989	18.000	24.972	24.993	29	—
—	—	18.987	19.000	26.972	26.993	30	—

[Remark] Limiting speed of grease lubrication should be kept to under 60 % of that for oil lubrication.

Drawn cup needle roller bearings

F_w 19.50 ~ (22) mm

Caged type

With open ends

With closed end

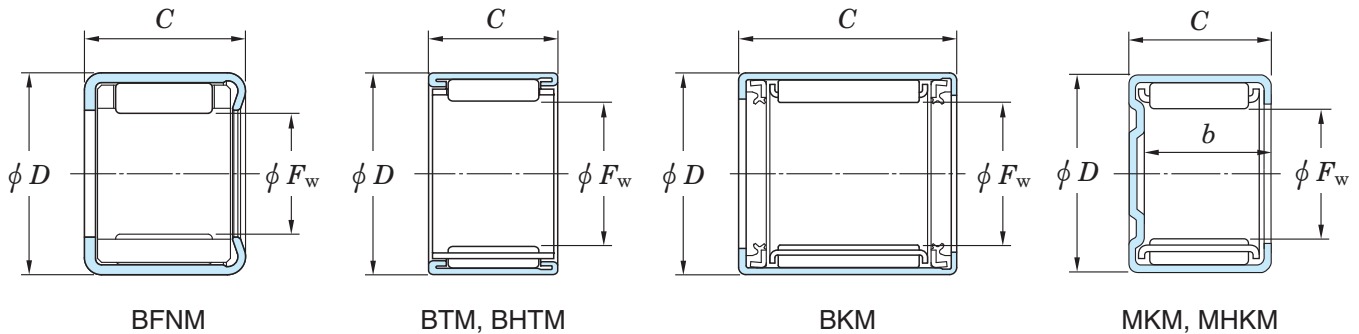

Boundary dimensions (mm)				Basic load ratings (kN)		Limiting speeds (min ⁻¹)	Bearing No. ²⁾	
F_w	D	C	$b_{min.}$	C_r	C_{0r}	Oil lub.	With open ends	With closed end
19.50	29	20	—	18.8	23.6	17 000	20BTM2920	—
20	26	12	9.6	10.6	20.4	6 300	—	—
	26	12	9.3	8.50	12.6	18 000	20BTM2612	20MKM2612
	26	14	—	15.1	31.4	6 300	—	—
	26	16	13.7	14.8	31.4	6 300	—	—
	26	16	13.3	12.4	20.3	18 000	BTM202616	20MKM2616
	26	20	17.2	18.8	42.5	6 300	—	—
	26	20	—	15.2	26.4	18 000	20BTM2620A	—
	27	13	10.6	13.1	22.2	6 200	—	—
	27	15	—	15.6	27.7	6 200	—	—
	27	15	—	13.1	18.7	18 000	BTM2015	—
	27	20	17.3	17.7	27.6	18 000	BTM202720-1	MKM2020
	27	23.50	—	18.4	28.8	10 000 ¹⁾	BKM2024JAU	—
	27	25	—	22.1	36.6	18 000	BTM202725	—
	27	26	—	18.4	28.8	10 000 ¹⁾	BKM2026JUU	—
	27	26	—	27.6	58.0	6 200	—	—
27	30	—	21.8	36.0	10 000 ¹⁾	BKM2030JUU	—	
27	30	27.3	25.4	43.8	18 000	BTM202730	MKM2030	
27	35	—	28.7	45.4	10 000 ¹⁾	BKM2035JUU	—	
28	20	—	17.4	22.3	17 000	20BTM2820A	—	
21	27	20	—	20.5	47.6	6 100	—	—
22	28	12	9.6	11.6	22.9	5 800	—	—
	28	12	9.3	9.10	13.5	16 000	22BTM2812	22MKM2812
	28	16	13.7	16.1	35.0	5 800	—	—
	28	16	13.3	12.7	20.8	16 000	22BTM2816A	22MKM2816
	28	20	17.2	20.3	47.2	5 800	—	—

- [Notes] 1) The limiting speeds shown above are applicable when oil seal is used and the bearing is lubricated with grease.
 2) FN in bearing number indicates a bearing comprising polyamide molded cage.
 3) The recommended dimensional tolerances of shaft shown above are applicable except h6.
 4) The recommended dimensional tolerances of housing bore shown above are applicable except N7.

Full complement type

With open ends

With closed end

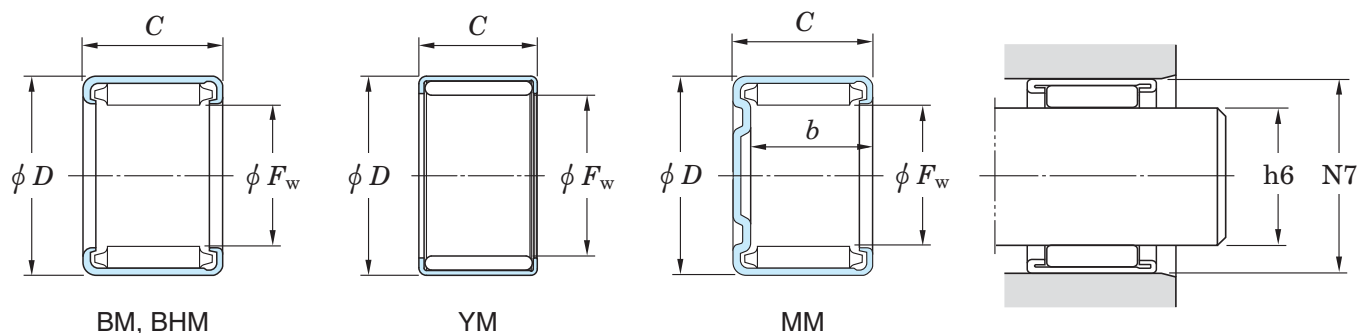

Full complement type		Recommended dimensions (mm)				(Refer.) Mass (g)	
		Shaft dia. (h6)		Housing bore dia. (N7)		With open ends	With closed end
With open ends	With closed end	min.	max.	min.	max.		
—	—	19.487	19.500	28.972	28.993	36	—
20BM2612	20MM2612	19.987	20.000	25.972	25.993	15	17
—	—	19.987	20.000	25.972	25.993	14	16
YM202614	—	19.987	20.000	25.972	25.993	19	—
20BM2616	20MM2616	19.987	20.000	25.972	25.993	21	23
—	—	19.987	20.000	25.972	25.993	19	21
20BM2620	20MM2620	19.987	20.000	25.972	25.993	26	30
—	—	19.987	20.000	25.972	25.993	24	—
BM2013	MM2013	19.987	20.000	26.972	26.993	18	21
BM2015	—	19.987	20.000	26.972	26.993	22	—
—	—	19.870	20.000	26.972	26.993	20	—
—	—	19.987	20.000	26.972	26.993	25	28
—	—	19.987	20.000	26.972	26.993	32	—
—	—	19.987	20.000	26.972	26.993	33	—
—	—	19.987	20.000	26.972	26.993	33	—
BM2026	—	19.987	20.000	26.972	26.993	40	—
—	—	19.987	20.000	26.972	26.993	38	—
—	—	19.987	20.000	26.972	26.993	40	45
—	—	19.987	20.000	26.972	26.993	45	—
—	—	19.987	20.000	27.991 ⁴⁾	28.012 ⁴⁾	31	—
21YM2720J	—	20.987	21.000	26.972	26.993	29	—
22BM2812	22MM2812	21.987	22.000	27.972	27.993	16	18
—	—	21.987	22.000	27.972	27.993	14	16
22BM2816	22MM2816	21.987	22.000	27.972	27.993	22	25
—	—	21.987	22.000	27.972	27.993	19	22
22BM2820	22MM2820	21.987	22.000	27.972	27.993	29	32

[Remark] Limiting speed of grease lubrication should be kept to under 60 % of that for oil lubrication.

Drawn cup needle roller bearings

F_w (22) ~ (25) mm

Caged type

With open ends

With closed end

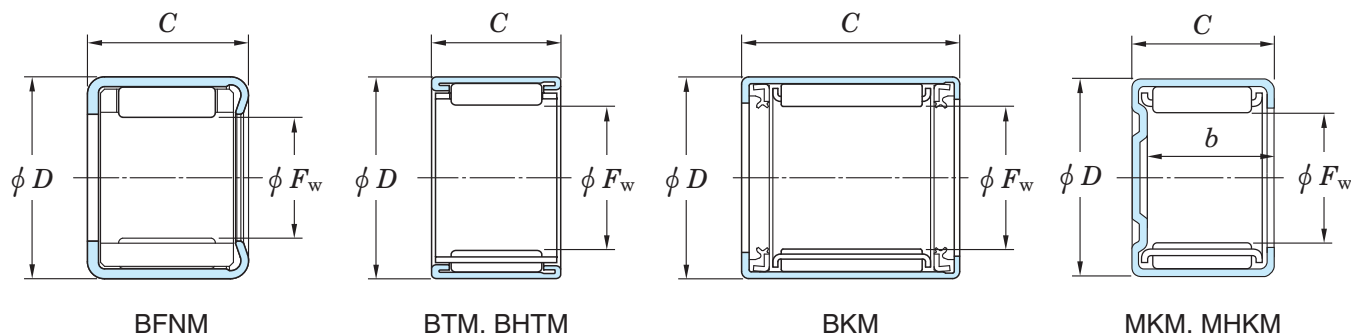

Boundary dimensions (mm)				Basic load ratings (kN)		Limiting speeds (min ⁻¹)	Bearing No. ²⁾	
F_w	D	C	$b_{min.}$	C_r	C_{0r}	Oil lub.	With open ends	With closed end
22	28	20	17.3	14.9	26.5	17 000	22BTM2820	22MKM2820
	28	20	—	21.0	49.5	5 800	—	—
	29	12	—	9.22	13.0	16 000	BTM2212	—
	29	15	—	12.0	18.3	16 000	BTM2215	—
	29	20	—	21.9	45.2	5 700	—	—
	29	20	17.3	16.2	26.7	16 000	BTM2220A	MKM2220
	29	25	—	20.4	36.1	16 000	BTM2225	—
	30	18	—	16.7	24.5	16 000	22BTM3018	—
24	30	13	—	9.55	15.7	15 000	BTM243013J	—
	31	20	17.3	17.7	29.4	15 000	BTM2420	MKM2420
	31	25	—	31.6	65.4	5 200	—	—
	31	28	—	23.9	43.0	15 000	BTM2428	—
	35	20	18.0	21.0	25.8	14 000	—	24MKM3520
25	31	19	—	16.3	30.1	15 000	25BTM3119A	—
	32	12	9.3	9.05	12.4	14 000	BTM2512	MKM2512
	32	16	—	18.7	37.9	5 100	—	—
	32	16	13.3	15.3	24.6	14 000	BTM2516	MKM2516
	32	20	17.2	23.8	51.7	5 100	—	—
	32	20	—	19.1	32.5	14 000	BTM2520A	MTM2520M
	32	26	—	30.9	72.4	5 100	—	—
	32	26	23.3	23.7	43.1	14 000	BTM2526	MKM2526
	33	10	—	8.50	10.3	14 000	BHTM2510A	—
	33	15	—	19.5	32.0	5 000	—	—
	33	15	—	13.9	19.7	14 000	BHTM2515-1	—
	33	20	17.3	19.2	29.7	14 000	BHTM2520-1	MHKM2520
	33	25	—	31.3	66.3	5 000	—	—
	33	25	—	24.5	40.6	14 000	BHTM2525	—

- [Notes] 1) The limiting speeds shown above are applicable when oil seal is used and the bearing is lubricated with grease.
 2) FN in bearing number indicates a bearing comprising polyamide molded cage.
 3) The recommended dimensional tolerances of shaft shown above are applicable except h6.
 4) The recommended dimensional tolerances of housing bore shown above are applicable except N7.

Full complement type

With open ends

With closed end

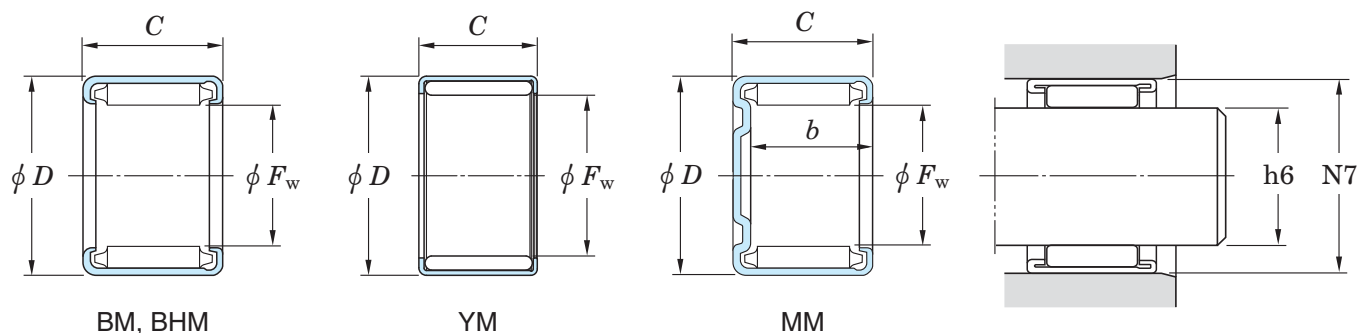

Full complement type		Recommended dimensions (mm)				(Refer.) Mass (g)			
		Shaft dia. (h6)		Housing bore dia. (N7)		With open ends	With closed end		
With open ends	With closed end	min.	max.	min.	max.				
—	—	21.987	22.000	27.972	27.993	25	28		
		YM222820	—	21.987	22.000	27.972	27.993	30	—
		—	—	21.987	22.000	28.972	28.993	19	—
BM2220B	—	21.987	22.000	28.972	28.993	22	—		
		—	—	21.987	22.000	28.972	28.993	33	—
		—	—	21.987	22.000	28.972	28.993	30	33
—	—	21.987	22.000	28.972	28.993	37	—		
—	—	21.987	22.000	29.972	29.993	31	—		
BM2425A	—	23.987	24.000	29.991 ⁴⁾	30.012 ⁴⁾	47	—		
		—	—	23.987	24.000	30.967	30.992	31	35
		—	—	23.987	24.000	30.989 ⁴⁾	31.014 ⁴⁾	45	—
		—	—	23.987	24.000	30.967	30.992	44	—
		—	—	23.987	24.000	34.967	34.992	—	52
BM2516	—	24.987	25.000	30.967	30.992	26	—		
		—	—	24.987	25.000	31.967	31.992	19	21
		—	—	24.987	25.000	31.967	31.992	28	—
BM2520	MM2520	24.987	25.000	31.967	31.992	26	30		
		—	—	24.987	25.000	31.967	31.992	36	41
		—	—	24.987	25.000	31.967	31.992	33	—
BM2526	—	24.987	25.000	31.967	31.992	48	—		
		—	—	24.987	25.000	31.967	31.992	42	48
		—	—	24.987	25.000	32.989 ⁴⁾	33.014 ⁴⁾	18	—
BHM2515	—	24.987	25.000	32.989 ⁴⁾	33.014 ⁴⁾	30	—		
		—	—	24.987	25.000	32.967	32.992	27	—
		—	—	24.987	25.000	32.967	32.992	37	41
BHM2525	—	24.987	25.000	32.967	32.992	53	—		
		—	—	24.987	25.000	32.967	32.992	46	—

[Remark] Limiting speed of grease lubrication should be kept to under 60 % of that for oil lubrication.

Drawn cup needle roller bearings

F_w (25) ~ (30) mm

Caged type

With open ends

With closed end

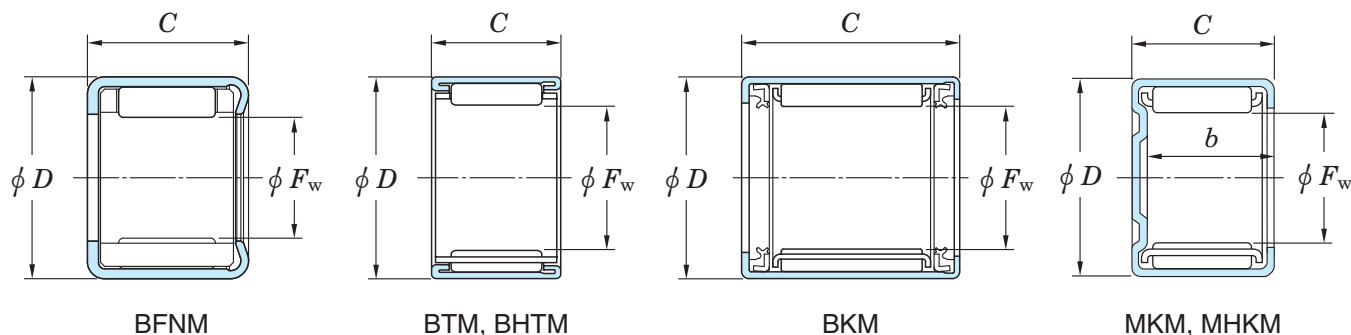

Boundary dimensions (mm)				Basic load ratings (kN)		Limiting speeds (min ⁻¹)	Bearing No. ²⁾	
F_w	D	C	$b_{min.}$	C_r	C_{0r}	Oil lub.	With open ends	With closed end
25	33	30	—	37.4	83.3	5 000	—	—
	33	30	27.3	27.7	47.4	14 000	BHTM2530-1	MHKM2530
	33	35	—	29.8	52.3	8 000 ¹⁾	BHKM2535JU	—
25.80	33	16	—	14.2	22.4	14 000	BTM263316A	—
26	31.40	12	—	8.60	14.5	14 000	BKM263112A	—
	34	16	13.3	15.3	22.5	14 000	BHTM2616	MHKM2616
	34	20	17.3	20.0	31.6	14 000	BHTM2620A	MHKM2620
28	34	17	—	16.8	49.7	4 600	—	—
	34	24	—	29.0	76.7	4 600	—	—
	34	25	—	34.8	85.9	4 600	—	—
	35	16	13.7	20.2	42.9	4 600	—	—
	35	16	13.3	15.9	26.2	13 000	28BTM3516	28MKM3516
	35	20	17.2	25.7	58.3	4 600	—	—
	35	20	17.3	19.0	33.1	13 000	28BTM3520	28MKM3520
	36	20.75	—	22.8	39.3	13 000	BTM283621JA	—
	36	23	—	22.8	39.3	13 000	BTM283623J	—
	37	20	17.3	21.6	33.0	13 000	BTM283720	MHKM2820
	37	30	—	43.7	94.7	4 400	—	—
	37	30	27.3	32.8	56.5	13 000	BHTM2830	MHKM2830
39	30	—	44.5	85.9	4 300	—	—	
30	37	12	9.3	12.1	18.8	12 000	BTM303712	30MKM3712
	37	16	—	21.1	28.2	4 300	—	—
	37	16	13.3	17.1	29.3	12 000	30BTM3716BM	30MKM3716
	37	20	17.2	26.8	62.5	4 300	—	—
	37	20	17.3	20.7	40.4	12 000	30BTM3720	30MKM3720
	37	20	—	32.2	70.1	4 300	—	—

- [Notes] 1) The limiting speeds shown above are applicable when oil seal is used and the bearing is lubricated with grease.
 2) FN in bearing number indicates a bearing comprising polyamide molded cage.
 3) The recommended dimensional tolerances of shaft shown above are applicable except h6.
 4) The recommended dimensional tolerances of housing bore shown above are applicable except N7.

Full complement type

With open ends

With closed end

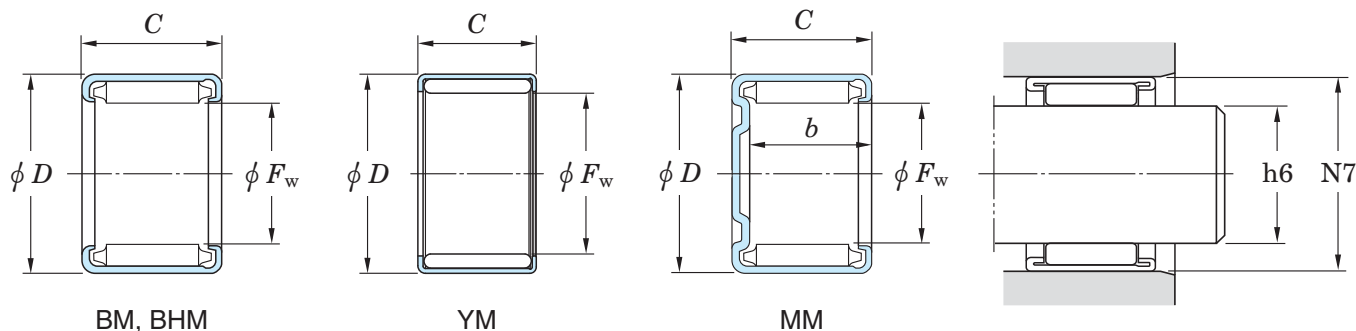

Full complement type With open ends With closed end		Recommended dimensions (mm)				(Refer.) Mass (g)	
		Shaft dia. (h6)		Housing bore dia. (N7)		With open ends	With closed end
		min.	max.	min.	max.		
BHM2530	—	24.987	25.000	32.989 ⁴⁾	33.014 ⁴⁾	65	—
—	—	24.987	25.000	32.967	32.992	54	61
—	—	24.987	25.000	32.967	32.992	62	—
—	—	25.787	25.800	32.967	32.992	28	—
—	—	25.987	26.000	31.389 ⁴⁾	31.414 ⁴⁾	14	—
—	—	25.987	26.000	33.967	33.992	30	34
—	—	25.987	26.000	33.967	33.992	38	43
BM2817	—	27.987	28.000	33.967	33.992	29	—
BM2824	—	27.987	28.000	33.967	33.992	42	—
YM2825B	—	27.991 ³⁾	28.000 ³⁾	33.975 ⁴⁾	34.000 ⁴⁾	45	—
28BM3516	28MM3516	27.987	28.000	34.967	34.992	95	107
—	—	27.987	28.000	34.967	34.992	28	31
28BM3520	28MM3520	27.987	28.000	34.967	34.992	118	133
—	—	27.987	28.000	34.967	34.992	35	39
—	—	27.987	28.000	35.967	35.992	43	—
—	—	27.987	28.000	35.967	35.992	49	—
—	—	27.987	28.000	36.967	36.992	46	52
28BHM3730	—	27.980 ³⁾	27.993 ³⁾	36.989 ⁴⁾	37.014 ⁴⁾	80	—
—	—	27.987	28.000	36.967	36.992	70	79
BM283930A	—	27.980 ³⁾	27.993 ³⁾	38.989 ⁴⁾	39.014 ⁴⁾	100	—
—	—	29.987	30.000	36.967	36.992	22	25
30BM3716	—	29.987	30.000	36.967	36.992	33	—
—	—	29.987	30.000	36.967	36.992	30	33
30BM3720	30MM3720	29.987	30.000	36.967	36.992	42	48
—	—	29.987	30.000	36.967	36.992	40	45
30YM3720	—	29.987	30.000	36.967	36.992	45	—

[Remark] Limiting speed of grease lubrication should be kept to under 60 % of that for oil lubrication.

Drawn cup needle roller bearings

F_w (30) ~ (35) mm

Caged type

With open ends

With closed end

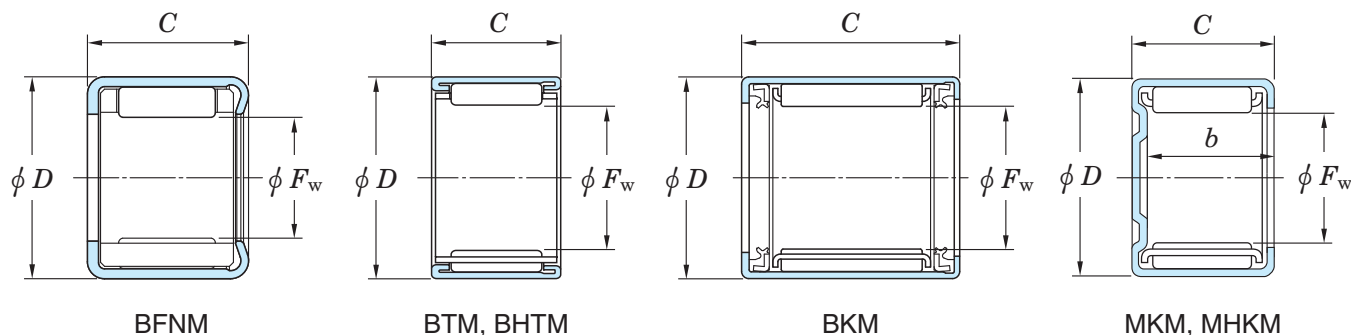

Boundary dimensions (mm)				Basic load ratings (kN)		Limiting speeds (min ⁻¹)	Bearing No. ²⁾	
F_w	D	C	$b_{min.}$	C_r	C_{0r}	Oil lub.	With open ends	With closed end
30	37	26	—	34.8	87.3	4 300	—	—
	37	26	23.3	26.7	52.0	12 000	30BTM3726	30MKM3726
	37	26	—	37.1	94.9	4 300	—	—
	38	21	—	23.4	40.4	12 000	BTM3021A	—
	38	25	—	38.0	79.8	4 200	—	—
	40	15	—	16.6	22.3	12 000	BHTM3015	—
	40	20	17.3	23.1	34.0	12 000	BHTM3020	MHKM3020
	40	25	—	37.3	75.4	4 100	—	—
	40	25	—	29.4	46.5	12 000	BHTM3025-1	—
	40	30	27.3	35.3	58.8	12 000	BHTM3030-1A	MHKM3030
40	30	—	30.8	49.3	6 600 ¹⁾	BKM304030JU	—	
31	39	17.80	—	20.6	34.6	12 000	31BTM3918A	—
32	38	11	—	4.90	6.75	12 000	32BTM3811A	—
	40	20	—	31.9	73.3	4 000	—	—
	40	25	—	27.6	50.8	11 000	32BTM4025PL	—
	42	20	17.3	23.4	34.8	11 000	BHTM3220A	MHKM3220
	42	20	—	37.4	69.1	3 900	—	—
	42	30	27.3	36.6	61.9	11 000	BHTM3230	MHKM3230
42	30	—	55.0	113	3 900	—	—	
33.50	40	17	—	16.8	33.5	11 000	BTM344017A	—
34	40	12	—	7.30	11.7	11 000	34BTM4012A	—
	42	25	—	37.2	94.1	3 800	—	—
35	40.50	26	—	22.7	56.0	11 000	BSM354126AJ	—
	42	12	—	13.3	22.8	11 000	BTM3512	—
	42	16	—	22.2	52.9	3 700	—	—

- [Notes] 1) The limiting speeds shown above are applicable when oil seal is used and the bearing is lubricated with grease.
 2) FN in bearing number indicates a bearing comprising polyamide molded cage.
 3) The recommended dimensional tolerances of shaft shown above are applicable except h6.
 4) The recommended dimensional tolerances of housing bore shown above are applicable except N7.

Full complement type

With open ends

With closed end

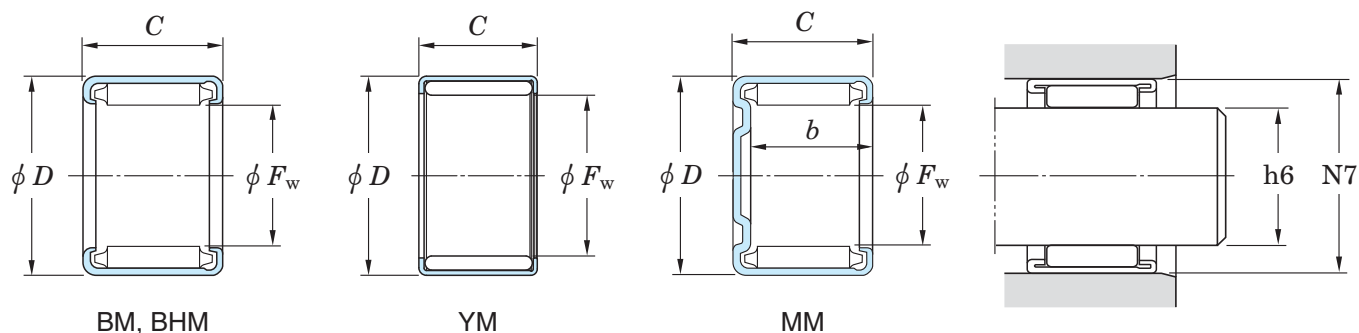

Full complement type		Recommended dimensions (mm)				(Refer.) Mass (g)	
		Shaft dia. (h6)		Housing bore dia. (N7)		With open ends	With closed end
With open ends	With closed end	min.	max.	min.	max.		
30BM3726	—	29.987	30.000	36.967	36.992	56	—
—	—	29.987	30.000	36.967	36.992	48	55
30YM3726	—	29.987	30.000	36.967	36.992	60	—
—	—	29.987	30.000	37.967	37.992	45	—
BM3025	—	29.987	30.000	37.989 ⁴⁾	38.014 ⁴⁾	62	—
—	—	29.987	30.000	39.967	39.992	41	—
—	—	29.987	30.000	39.967	39.992	55	62
BHM3025	—	29.987	30.000	39.987 ⁴⁾	40.013 ⁴⁾	80	—
—	—	29.987	30.000	39.967	39.992	69	—
—	—	29.987	30.000	39.967	39.992	83	94
—	—	29.987	30.000	39.967	39.992	77	—
—	—	30.984	31.000	38.967	38.992	39	—
—	—	31.975 ³⁾	31.991 ³⁾	38.000 ⁴⁾	38.025 ⁴⁾	15	—
32YM4020P	—	31.984	32.000	39.989 ⁴⁾	40.014 ⁴⁾	56	—
—	—	31.984	32.000	39.989 ⁴⁾	40.014 ⁴⁾	57	—
—	—	31.984	32.000	41.989 ⁴⁾	42.014 ⁴⁾	57	64
YM3220	—	31.995 ³⁾	32.011 ³⁾	41.989 ⁴⁾	42.014 ⁴⁾	71	—
—	—	31.984	32.000	41.967	41.992	86	98
YM3230	—	31.995 ³⁾	32.011 ³⁾	41.989 ⁴⁾	42.014 ⁴⁾	109	—
—	—	33.484	33.500	39.967	39.992	34	—
—	—	33.984	34.000	39.967	39.992	20	—
34YM4225	—	33.959 ³⁾	33.975 ³⁾	41.967	41.992	74	—
—	—	34.984	35.000	40.467	40.492	44	—
—	—	34.984	35.000	41.967	41.992	26	—
BM3516	—	34.984	35.000	41.967	41.992	38	—

[Remark] Limiting speed of grease lubrication should be kept to under 60 % of that for oil lubrication.

Drawn cup needle roller bearings

F_w (35) ~ (40) mm

Caged type

With open ends

With closed end

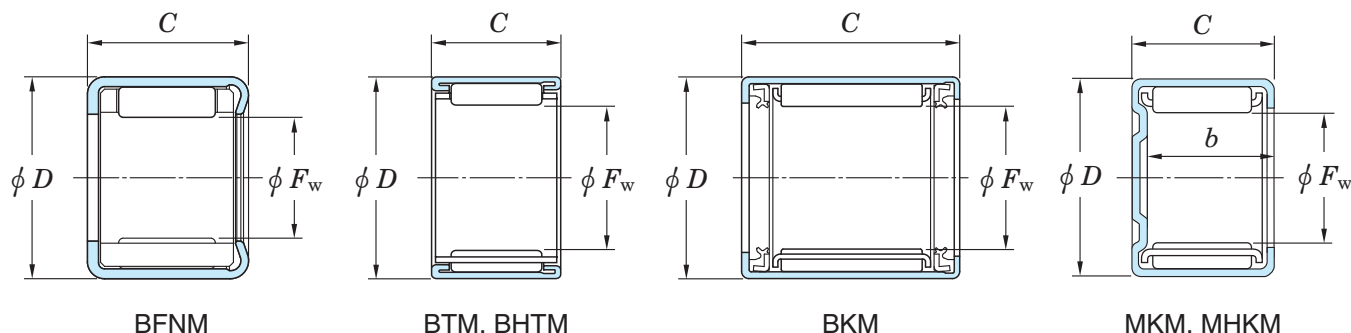

Boundary dimensions (mm)				Basic load ratings (kN)		Limiting speeds (min ⁻¹)	Bearing No. ²⁾	
F_w	D	C	b min.	C_r	C_{0r}	Oil lub.	With open ends	With closed end
35	42	16	13.3	18.5	34.7	11 000	BTM3516	MKM3516
	42	20	—	13.3	22.8	5 700 ¹⁾	BKM354220-1UU	—
	42	20	17.2	28.2	72.2	3 700	—	—
	42	20	17.3	23.4	47.0	11 000	BTM3520	MKM3520
	42	21	—	28.8	79.2	3 700	—	—
	42	26	—	36.7	101	3 700	—	—
	42	26	23.3	30.1	65.2	11 000	BTM3526	MKM3526
	42	28	—	31.3	68.6	11 000	BTM3528	—
	42	46	—	26.2	57.5	5 700 ¹⁾	BKM354246UUH	—
	45	15	—	18.4	26.6	10 000	BHTM3515	—
	45	18	—	20.5	33.4	3 600	—	—
	45	20	17.3	26.0	41.7	10 000	BHTM3520	MHKM3520
	45	25	—	32.8	56.2	10 000	BHTM3525	—
	45	30	27.3	39.4	71.0	10 000	BHTM3530	MHKM3530
36	42	16	—	19.6	55.9	3 700	—	—
	44	25	—	42.0	99.2	3 600	—	—
	48	24	—	33.2	48.7	9 800	36BTM4824	—
37	43	12	—	8.00	13.6	10 000	37BTM4312A	—
	47	20	17.3	25.1	39.9	9 800	BTM3720	MKM3720
	47	30	27.3	38.2	68.4	9 800	BTM3730	MKM3730
38	45	12	—	12.7	23.0	9 800	BTM384512A	—
	48	20	17.3	27.1	44.5	9 500	BTM3820A	MKM3820
	48	20	—	42.0	82.8	3 300	—	—
	48	30	27.3	41.2	76.2	9 500	BTM3830PL	MKM3830
	48	45	—	58.9	121	9 500	BTM3845-OH	—
40	47	12	—	9.75	10.4	9 400	40BTM4712A	—

- [Notes] 1) The limiting speeds shown above are applicable when oil seal is used and the bearing is lubricated with grease.
 2) FN in bearing number indicates a bearing comprising polyamide molded cage.
 3) The recommended dimensional tolerances of shaft shown above are applicable except h6.
 4) The recommended dimensional tolerances of housing bore shown above are applicable except N7.

Full complement type

With open ends

With closed end

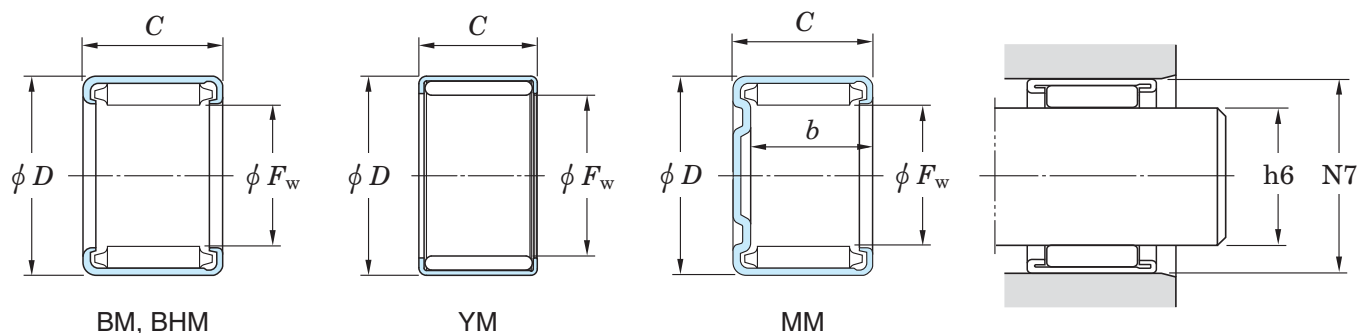

Full complement type		Recommended dimensions (mm)				(Refer.) Mass (g)	
		Shaft dia. (h6)		Housing bore dia. (N7)		With open ends	With closed end
With open ends	With closed end	min.	max.	min.	max.		
—	—	34.984	35.000	41.967	41.992	35	39
—	—	34.984	35.000	41.967	41.992	38	—
BM3520	MM3520	34.984	35.000	41.967	41.992	49	56
—	—	34.984	35.000	41.989 ⁴⁾	42.014 ⁴⁾	43	49
YM3521A	—	34.984	35.000	41.989 ⁴⁾	42.014 ⁴⁾	55	—
BM3526	—	34.984	35.000	41.967	41.992	66	—
—	—	34.984	35.000	41.967	41.992	57	64
—	—	34.984	35.000	41.967	41.992	63	—
—	—	34.984	35.000	41.967	41.992	101	—
—	—	34.984	35.000	44.967	44.992	47	—
BHM3518	—	34.984	35.000	44.967	44.992	62	—
—	—	34.984	35.000	44.967	44.992	64	72
—	—	34.984	35.000	44.967	44.992	80	—
—	—	34.984	35.000	44.967	44.992	96	109
36BM4216	—	35.984	36.000	41.967	41.992	35	—
36YM4425L	—	35.975 ³⁾	35.991 ³⁾	43.967	43.992	78	—
—	—	35.984	36.000	47.967	47.992	95	—
—	—	36.984	37.000	42.967	42.992	23	—
—	—	36.984	37.000	46.967	46.992	64	72
—	—	36.984	37.000	46.967	46.992	96	109
—	—	37.984	38.000	44.967	44.992	29	—
—	—	37.984	38.000	47.967	47.992	67	76
YM3820P	—	37.984	38.000	47.967	47.992	82	—
—	—	37.984	38.000	47.967	47.992	102	115
—	—	37.984	38.000	47.967	47.992	151	—
—	—	39.984	40.000	46.967	46.992	27	—

[Remark] Limiting speed of grease lubrication should be kept to under 60 % of that for oil lubrication.

Drawn cup needle roller bearings

F_w (40) ~ 45 mm

Caged type

With open ends

With closed end

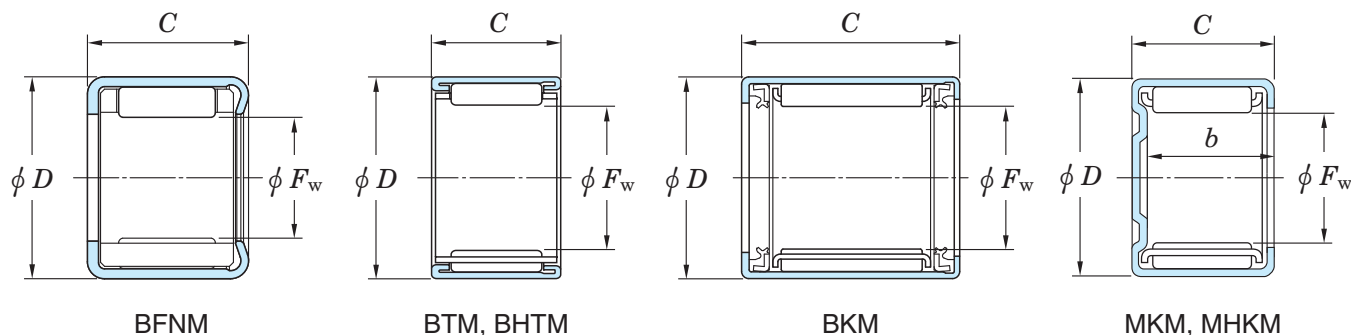

Boundary dimensions (mm)				Basic load ratings (kN)		Limiting speeds (min ⁻¹)	Bearing No. ²⁾	
F_w	D	C	b min.	C_r	C_{0r}	Oil lub.	With open ends	With closed end
40	47	16	—	23.8	60.5	3 300	—	—
	47	16	13.3	18.7	37.1	9 400	40BTM4716	40MKM4716
	47	20	17.2	30.3	82.6	3 300	—	—
	47	20	17.3	23.7	50.4	9 400	40BTM4720	40MKM4720
	50	15	—	23.4	45.2	3 200	—	—
	50	15	—	20.2	31.2	9 100	BTM4015	—
	50	20	17.3	28.5	48.5	9 100	BTM4020	MKM4020
	50	25	—	36.2	66.2	9 100	BTM4025	—
	50	30	27.3	43.0	82.5	9 100	BTM4030-1	MKM4030
	50	40	—	54.8	113	9 100	BTM4040-OH	—
	51	20	—	40.2	84.7	3 200	—	—
	51	30	—	43.5	76.6	9 000	40BTM5130J	—
	53	20	—	46.7	87.3	3 100	—	—
41.50	46.50	8.50	—	7.00	13.9	9 200	BTM424709AJ	—
42	53	30	—	45.7	83.9	8 600	BTM425330J	—
43	49	12	—	8.35	15.1	8 800	43BTM4912A	—
43.52	48.52	14	—	12.0	29.0	8 800	44BTM4914A	—
45	52	12	—	13.7	26.9	8 400	45BTM5212A	—
	52	16	—	23.8	65.9	2 900	—	—
	52	16	13.3	19.1	41.3	8 400	45BTM5216	45MKM5216
	52	20	17.2	30.4	90.1	2 900	—	—
	52	20	17.3	23.3	33.4	8 200	45BTM5220A	MKM4520
	52	30	27.3	45.3	91.7	8 200	BTM4530	MKM4530
	55	20	—	30.0	53.9	8 200	BTM4520A	—

- [Notes] 1) The limiting speeds shown above are applicable when oil seal is used and the bearing is lubricated with grease.
 2) FN in bearing number indicates a bearing comprising polyamide molded cage.
 3) The recommended dimensional tolerances of shaft shown above are applicable except h6.
 4) The recommended dimensional tolerances of housing bore shown above are applicable except N7.

Full complement type

With open ends

With closed end

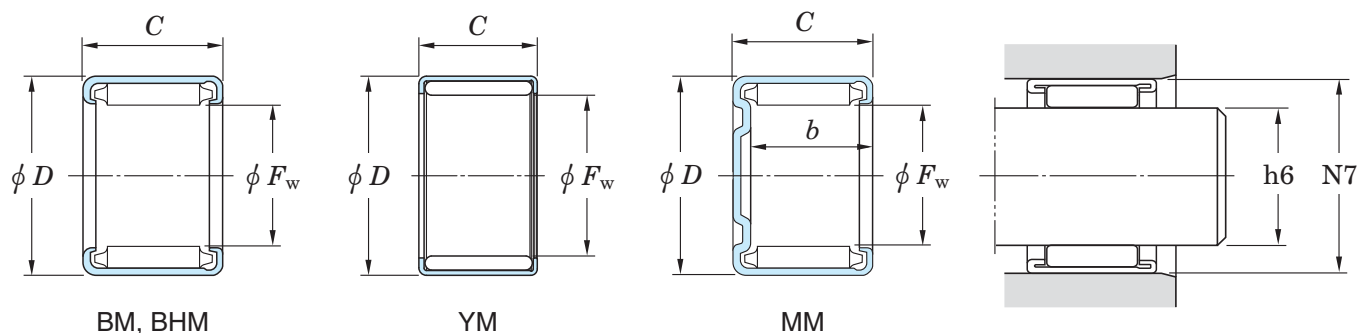

Full complement type		Recommended dimensions (mm)				(Refer.) Mass (g)	
		Shaft dia. (h6)		Housing bore dia. (N7)		With open ends	With closed end
With open ends	With closed end	min.	max.	min.	max.		
40BM4716	—	39.984	40.000	46.967	46.992	43	—
—	—	39.984	40.000	46.967	46.992	39	44
40BM4720	40MM4720	39.984	40.000	46.967	46.992	56	63
—	—	39.984	40.000	46.967	46.992	48	55
BM4015-1	—	39.984	40.000	49.967	49.992	55	—
—	—	39.984	40.000	49.967	49.992	54	—
—	—	39.984	40.000	49.967	49.992	73	82
—	—	39.984	40.000	49.967	49.992	91	—
—	—	39.984	40.000	49.967	49.992	109	123
—	—	39.984	40.000	49.967	49.992	141	—
YM405120J	—	39.984	40.000	50.961	50.991	96	—
—	—	39.984	40.000	50.961	50.991	112	—
YM405320JM	—	39.984	40.000	52.961	52.991	114	—
—	—	41.484	41.500	46.467	46.492	15	—
—	—	41.984	42.000	52.961	52.991	121	—
—	—	42.984	43.000	48.989 ⁴⁾	49.014 ⁴⁾	25	—
—	—	43.504	43.520	48.487	48.512	28	—
—	—	44.984	45.000	51.961	51.991	34	—
45BM5216	—	44.984	45.000	51.961	51.991	49	—
—	—	44.984	45.000	51.961	51.991	45	51
45BM5220	45MM5220	44.984	45.000	51.961	51.991	62	71
—	—	44.984	45.000	54.961	54.991	79	90
—	—	44.984	45.000	54.961	54.991	120	136
—	—	44.984	45.000	54.961	54.991	79	—

[Remark] Limiting speed of grease lubrication should be kept to under 60 % of that for oil lubrication.

Drawn cup needle roller bearings

F_w 48 ~ 76.50 mm

Caged type

With open ends

With closed end

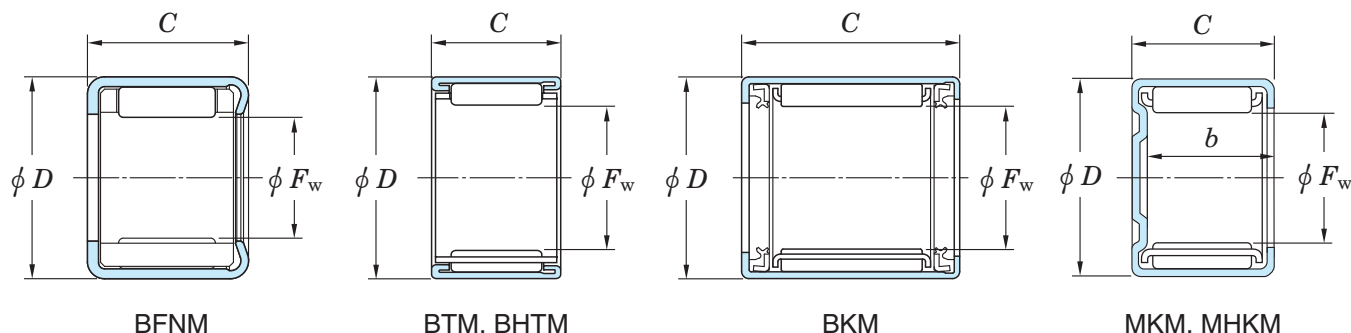

Boundary dimensions (mm)				Basic load ratings (kN)		Limiting speeds (min ⁻¹)	Bearing No. ²⁾	
F_w	D	C	b min.	C_r	C_{0r}	Oil lub.	With open ends	With closed end
48	56	30	—	41.0	100	7 800	BTM485630J	—
50	58	16	—	21.9	43.8	7 500	BTM505816J	—
	58	20	—	35.8	98.0	2 600	—	—
	58	20	17.3	28.4	61.0	7 500	50BTM5820J	50MKM5820
	58	25	—	45.2	133	2 600	—	—
	58	25	22.3	35.9	82.5	7 500	50BTM5825	50MKM5825
	62	15	—	24.3	36.4	7 300	BTM5015	—
	62	20	17.3	34.5	57.1	7 300	BTM5020	MKM5020
	62	25	—	43.9	77.8	7 300	BTM5025	—
55	62	30	27.3	52.8	98.5	7 300	BTM5030	MKM5030
	63	20	—	29.1	65.1	6 900	55BTM6320	—
64	67	20	—	36.4	63.1	6 700	55BTM6720A	—
	73.178	21.10	—	36.1	83.8	5 900	64BTM7321A	—
66	72	16	—	21.9	61.1	5 900	BTM667216J	—
71.60	78.60	15	—	22.9	61.9	5 400	BTM727915AJ	—
76.50	83.50	15	—	23.5	65.4	5 000	BTM778415AJ	—

- [Notes] 1) The limiting speeds shown above are applicable when oil seal is used and the bearing is lubricated with grease.
 2) FN in bearing number indicates a bearing comprising polyamide molded cage.
 3) The recommended dimensional tolerances of shaft shown above are applicable except h6.
 4) The recommended dimensional tolerances of housing bore shown above are applicable except N7.

Full complement type

With open ends

With closed end

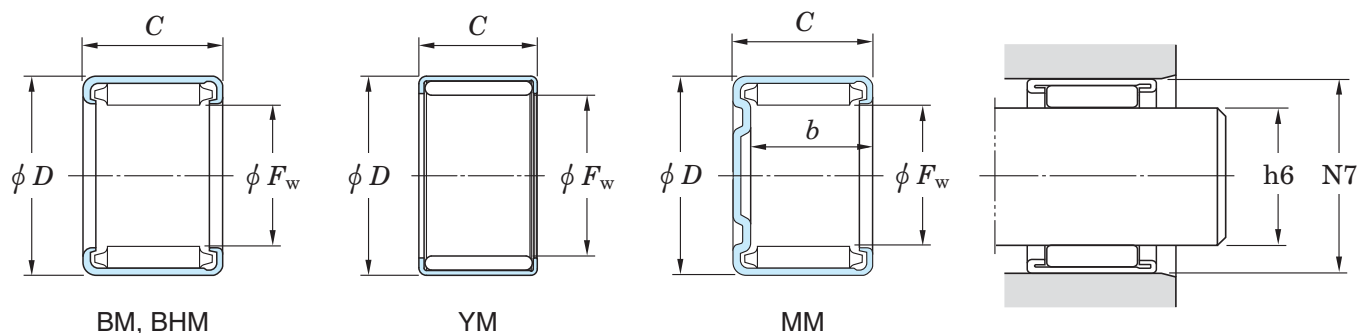

Full complement type		Recommended dimensions (mm)				(Refer.) Mass (g)	
		Shaft dia. (h6)		Housing bore dia. (N7)		With open ends	With closed end
With open ends	With closed end	min.	max.	min.	max.		
—	—	47.984	48.000	55.961	55.991	102	—
—	—	49.984	50.000	57.961	57.991	54	—
50BM5820	—	49.984	50.000	57.961	57.991	78	—
—	—	49.984	50.000	57.961	57.991	68	76
50BM5825	—	49.984	50.000	57.961	57.991	98	—
—	—	49.984	50.000	57.961	57.991	86	97
—	—	49.984	50.000	61.961	61.991	73	—
—	—	49.984	50.000	61.961	61.991	99	112
—	—	49.984	50.000	61.961	61.991	125	—
—	—	49.984	50.000	61.961	61.991	153	173
—	—	54.981	55.000	62.961	62.991	73	—
—	—	54.981	55.000	66.961	62.991	110	—
—	—	63.981	64.000	73.139	73.129	110	—
—	—	65.981	66.000	71.961	71.991	54	—
—	—	71.581	71.600	78.561	78.591	66	—
—	—	76.481	76.500	83.455	83.490	70	—

[Remark] Limiting speed of grease lubrication should be kept to under 60 % of that for oil lubrication.

Machined ring needle roller bearings

F_w 12 ~ 17 mm

Without inner ring

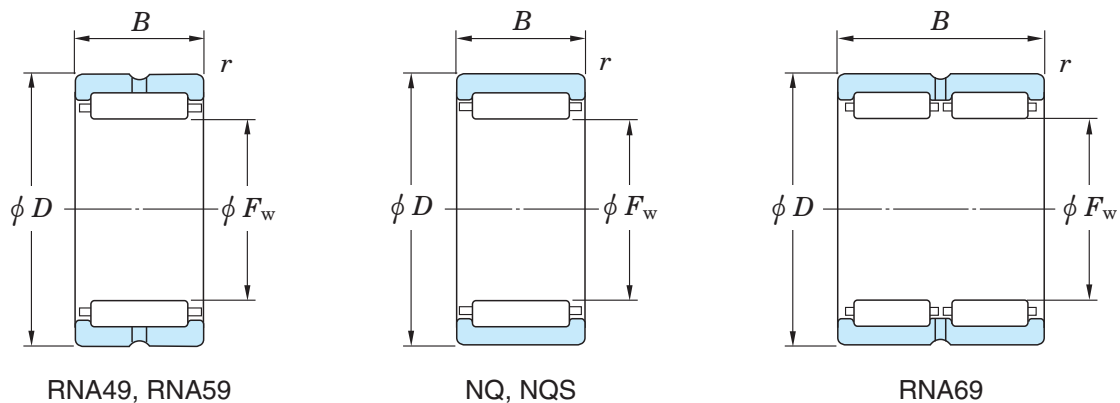

F_w	Boundary dimensions (mm)					Basic load ratings (kN)		Limiting speeds ¹⁾ (min ⁻¹)	Bearing No.
	d	D	B	B_1	$r_{min.}$	C_r	C_{0r}	Oil lub.	Without inner ring
12	—	19	10	—	0.3	5.9	6.3	35 000	NQ12/10
	—	24	9.8	—	0.3	5.9	6.3	35 000	12NQ2410A
14	10	22	13	14	0.3	7.5	7.7	14 000	—
	10	22	13	—	0.3	7.6	9.1	31 000	RNA4900
	10	22	13	—	0.3	9.3	10.1	30 000	RNA4900R
	—	22	16	—	0.5	11.7	13.7	30 000	NQ14/16D
15	—	23	12	—	0.3	8.8	9.7	29 000	NQ15/12
	—	24	10	—	0.3	8.5	8.2	28 000	15NQ2410D
	—	25	12	—	0.6	10.5	10.8	28 000	NQ152512
	—	26	16	—	0.3	13.4	14.8	28 000	NQS15/16
	—	28	15	—	1	7.9	9.8	28 000	15NQ2815
16	—	23	16	—	0.5	13.1	16.4	27 000	16NQ2316
	—	23	16	—	0.5	15.2	17.4	28 000	NQ15/16B
	—	23	22	—	0.5	17.1	23.0	27 000	16NQ2322A
	—	24	12	—	0.3	7.7	9.6	28 000	NQ16/12
	12	24	13	14	0.3	8.3	9.2	12 000	—
	12	24	13	—	0.3	8.6	11.1	28 000	RNA4901
	12	24	13	—	0.3	10.2	11.8	27 000	RNA4901R
	—	24	16	—	0.3	10.9	15.2	28 000	NQ16/16D
	12	24	16	16	0.3	10.9	15.2	28 000	—
	—	24	20	—	0.3	13.1	19.1	28 000	NQ16/20
17	—	25	16	—	0.5	11.3	16.2	26 000	NQ17/16D
	—	25	20	—	0.3	13.7	20.6	26 000	17NQ2520
	—	30	13	—	0.3	10.0	10.5	25 000	17NQ3013D
	—	32	16	—	0.6	18.0	16.5	23 000	17NQ3216D

[Note] 1) Limiting speeds of bearing number NA49...UU indicates the value of sealed and grease lubricated bearings.
 [Remark] Limiting speed of grease lubrication should be kept to under 60 % of that for oil lubrication.

With inner ring

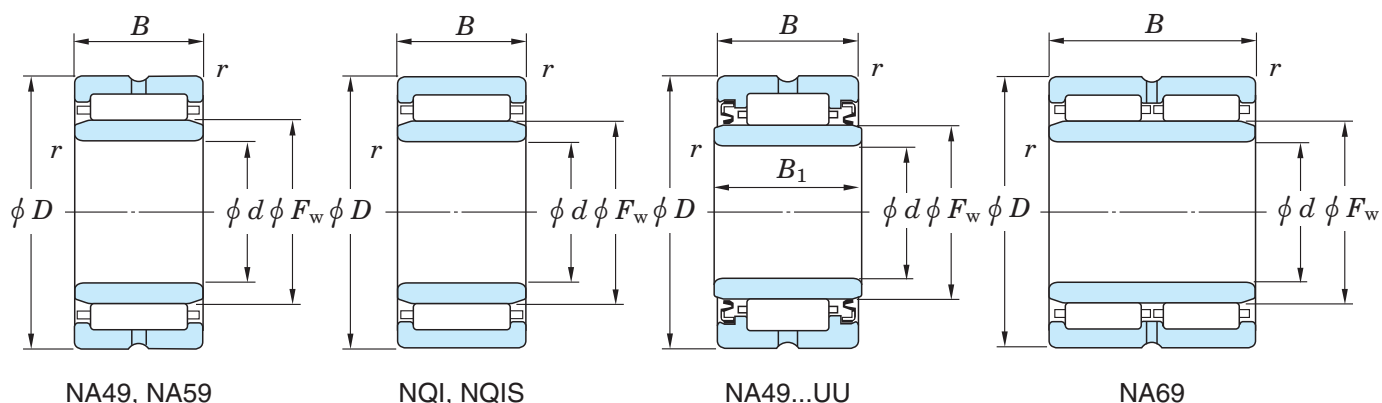

With inner ring	Mounting dimensions (mm)			(Refer.) Mass (kg)		(Refer.) Applicable inner ring No.
	d_a min.	D_a max.	r_a max.	Without inner ring	With inner ring	
—	—	17	0.3	0.010	—	—
—	—	22	0.3	0.023	—	—
NA4900UU	12	20	0.3	—	0.025	IRM101414
NA4900	12	20	0.3	0.017	0.025	IRM101413
NA4900R	12	20	0.3	0.016	0.023	IRM101413
—	—	19	0.5	0.021	—	—
—	—	21	0.3	0.017	—	—
—	—	22	0.3	0.016	—	—
—	—	21	0.6	0.022	—	—
—	—	24	0.3	0.034	—	—
—	—	23	1	0.043	—	—
—	—	20	0.5	0.018	—	—
—	—	20	0.5	0.020	—	—
—	—	20	0.5	0.025	—	—
—	—	22	0.3	0.019	—	—
NA4901UU	14	22	0.3	—	0.028	IRM121614
NA4901	14	22	0.3	0.019	0.028	IRM121613
NA4901R	14	22	0.3	0.018	0.027	IRM121613
—	—	22	0.3	0.025	—	—
NQI12/16D	14	22	0.3	—	0.036	—
—	—	22	0.3	0.032	—	—
NA6901	14	22	0.3	0.030	0.045	IRM121622
—	—	22	0.5	0.026	—	—
—	—	23	0.3	0.033	—	—
—	—	28	0.3	0.041	—	—
—	—	28	0.6	0.053	—	—

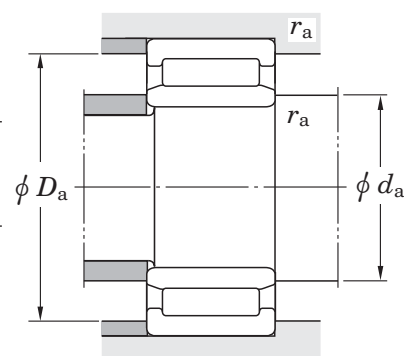

Machined ring needle roller bearings

F_w 18 ~ (22) mm

Without inner ring

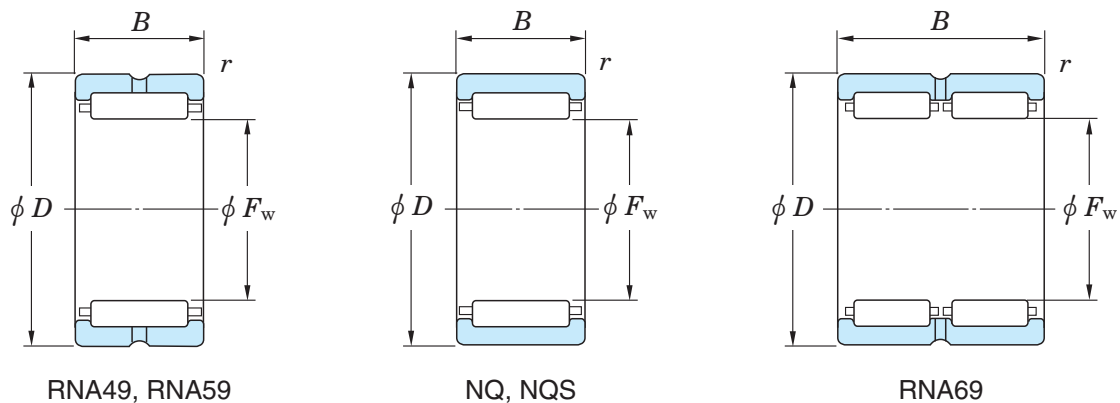

F_w	Boundary dimensions (mm)					Basic load ratings (kN)		Limiting speeds ¹⁾ (min ⁻¹)	Bearing No. Without inner ring
	d	D	B	B_1	$r_{min.}$	C_r	C_{0r}	Oil lub.	
18	—	25	16	—	0.3	11.7	17.2	25 000	18NQ2516 RNA49/14R NQ18/16 NQ18/20 18NQ2819 NQS18/16
	—	26	13	—	0.3	11.0	13.6	24 000	
	—	26	16	—	0.3	11.7	17.2	25 000	
	—	26	20	—	0.3	14.1	21.7	25 000	
	—	28	19	—	0.3	16.9	20.9	24 000	
	12	30	16	—	0.3	13.7	14.3	23 000	
19	15	27	16	—	0.3	12.1	18.2	24 000	—
20	—	27	17	—	0.3	14.7	20.4	22 000	20NQ2717 — RNA4902 RNA4902R NQ20/16D RNA5902 NQ20/20 NQ202823 20NQ3020 20NQ3212 NQ203218 20NQ3315D 20NQ3418D
	15	28	13	14	0.3	9.2	11.1	10 000	
	15	28	13	—	0.3	9.2	12.8	23 000	
	15	28	13	—	0.3	11.3	14.6	22 000	
	—	28	16	—	0.3	12.0	18.2	23 000	
	15	28	18	—	0.3	14.7	20.4	22 000	
	—	28	20	—	0.3	14.4	23.0	23 000	
	—	28	23	—	0.3	18.4	27.1	22 000	
	—	30	20	—	0.3	19.8	26.4	22 000	
	—	32	12	—	0.3	11.9	11.3	21 000	
	—	32	18	—	0.3	21.0	26.1	21 000	
	—	33	15	—	0.6	14.0	16.9	21 000	
21	—	38	17	—	0.6	21.1	21.1	19 000	21NQ3817
22	17	30	13	14	0.3	9.4	11.8	9 100	— RNA4903D RNA4903R NQ22/16 RNA5903 NQ22/20
	17	30	13	—	0.3	9.6	14.0	21 000	
	17	30	13	—	0.3	12.1	16.4	20 000	
	—	30	16	—	0.3	12.7	20.2	21 000	
	17	30	18	—	0.3	15.2	21.9	20 000	
	—	30	20	—	0.3	15.3	25.6	21 000	

[Note] 1) Limiting speeds of bearing number NA49...UU indicates the value of sealed and grease lubricated bearings.
[Remark] Limiting speed of grease lubrication should be kept to under 60 % of that for oil lubrication.

With inner ring

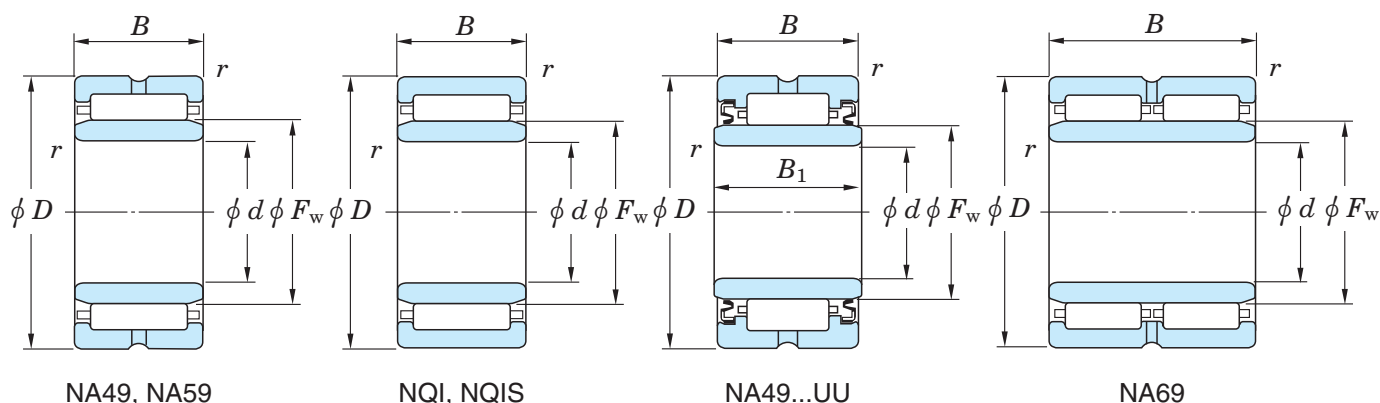

With inner ring	Mounting dimensions (mm)			(Refer.) Mass (kg)		(Refer.) Applicable inner ring No.
	d_a min.	D_a max.	r_a max.	Without inner ring	With inner ring	
—	—	23	0.3	0.023	—	—
—	—	24	0.3	0.020	—	—
—	—	24	0.3	0.027	—	—
—	—	24	0.3	0.035	—	—
—	—	26	0.3	0.042	—	—
NQIS12/16	14	28	0.3	0.044	0.057	—
NQI15/16	17	25	0.3	0.042	—	—
—	—	25	0.3	0.024	—	—
NA4902UU	17	26	0.3	—	0.037	IRM152014
NA4902	17	26	0.3	0.023	0.036	IRM152013
NA4902R	17	26	0.3	0.021	0.035	IRM152013
—	—	26	0.3	0.030	—	—
NA5902	17	26	0.3	0.029	0.048	IRM152018
—	—	26	0.3	0.038	—	—
—	—	26	0.3	0.040	—	—
—	—	28	0.3	0.048	—	—
—	—	30	0.3	0.033	—	—
—	—	30	0.3	0.053	—	—
—	—	29	0.6	0.052	—	—
—	—	30	0.6	0.060	—	—
—	—	34	0.6	0.082	—	—
NA4903UU	19	28	0.3	—	0.040	IRM172214
NA4903	19	28	0.3	0.025	0.040	IRM172213
NA4903R	19	28	0.3	0.023	0.038	IRM172213
—	—	28	0.3	0.032	—	—
NA5903	19	28	0.3	0.031	0.052	IRM172218
—	—	28	0.3	0.040	—	—

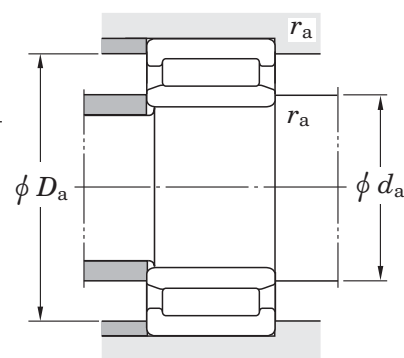

Machined ring needle roller bearings

F_w (22) ~ 28 mm

Without inner ring

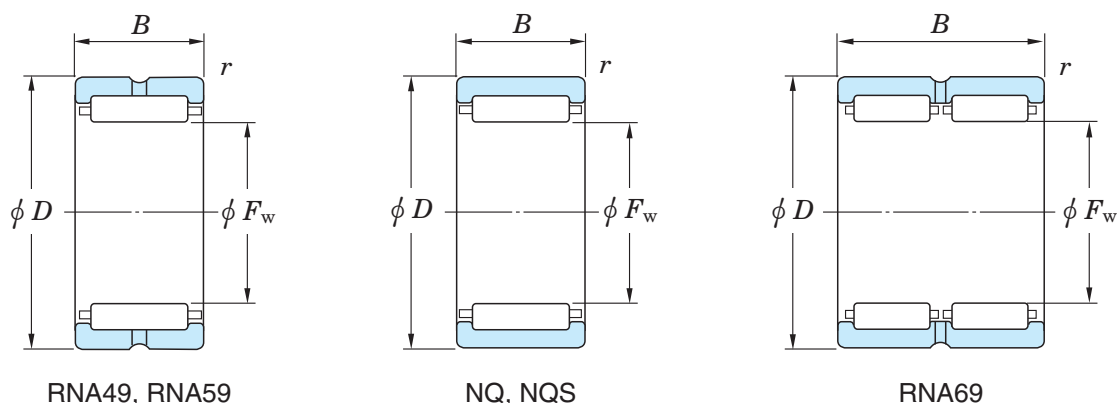

F_w	Boundary dimensions (mm)					Basic load ratings (kN)		Limiting speeds ¹⁾ (min ⁻¹)	Bearing No. Without inner ring
	d	D	B	B_1	$r_{min.}$	C_r	C_{0r}	Oil lub.	
22	17	30	23	—	0.3	18.9	29.0	20 000	RNA6903 22NQ3225
	—	32	25	—	0.3	22.4	31.7	20 000	
24	20	32	12	—	0.3	9.6	14.4	19 000	NQ24/12 NQ24/16 NQ24/20AD —
	20	32	16	—	0.3	13.4	22.2	19 000	
	—	32	20	—	0.3	17.3	26.5	19 000	
	20	32	20	20	0.3	17.3	26.5	19 000	
25	—	33	16	—	0.3	14.1	20.6	18 000	NQ25/16 NQ25/20
	—	33	20	—	0.3	18.9	30.0	18 000	
	20	37	14	—	0.3	17.1	19.1	17 000	—
	—	37	17	—	1	19.3	22.5	17 000	25NQ3717AD-1
	20	37	17	18	0.3	16.4	18.2	8 000	—
	20	37	17	—	0.3	15.9	21.1	18 000	RNA4904
	—	37	17	—	0.9	21.5	25.7	17 000	RNA4904ARD-1
	20	37	23	—	0.3	28.0	36.1	17 000	RNA5904 RNA6904
26	22	34	16	—	0.3	14.1	24.2	18 000	NQ26/16 26NQ3420 26NQ4717 26NQ5214
	—	34	20	—	0.3	14.2	28.9	18 000	
	—	47	17	—	0.6	21.4	23.6	16 000	
	—	52	14	—	0.6	18.0	18.9	16 000	
28	—	37	20	—	0.3	20.6	34.7	16 000	NQ283720D NQ28/30 RNA49/22 RNA49/22R RNA69/22 28NQ4017 28NQ4020
	—	37	30	—	0.3	29.1	54.1	16 000	
	22	39	17	—	0.3	17.8	25.4	16 000	
	—	39	17	—	0.3	21.8	29.8	16 000	
	22	39	30	—	0.3	36.8	53.1	16 000	
	—	40	17	—	0.3	15.1	27.4	16 000	
	—	40	20	—	0.3	20.6	34.7	16 000	

[Note] 1) Limiting speeds of bearing number NA49...UU indicates the value of sealed and grease lubricated bearings.
 [Remark] Limiting speed of grease lubrication should be kept to under 60 % of that for oil lubrication.

With inner ring

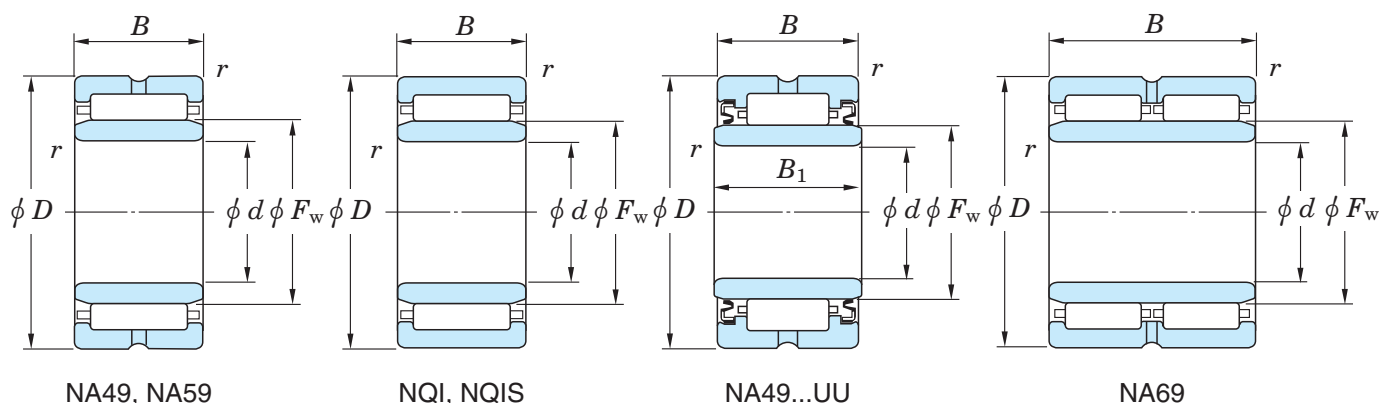

With inner ring	Mounting dimensions (mm)			(Refer.) Mass (kg)		(Refer.) Applicable inner ring No.
	d_a min.	D_a max.	r_a max.	Without inner ring	With inner ring	
NA6903	19	28	0.3	0.040	0.067	IRM172223
—	—	30	0.3	0.063	—	—
NQI20/12	22	30	0.3	0.025	0.038	—
NQI20/16	22	30	0.3	0.035	0.052	—
—	—	30	0.3	0.040	—	—
NQI203220AD	22	30	0.3	—	0.062	20IRM2420AD
—	—	31	0.3	0.034	—	—
—	—	31	0.3	0.043	—	—
20NQI3714	22	35	0.3	—	0.066	—
—	—	32	1	0.056	—	—
NA4904UU	22	35	0.3	—	0.078	IRM202518
NA4904	22	35	0.3	0.058	0.081	IRM202517
—	—	32	0.9	0.054	—	—
NA5904	22	35	0.3	0.073	0.104	IRM202523
NA6904	22	35	0.3	0.096	0.137	IRM202530
NQI22/16	24	32	0.3	0.037	0.056	—
—	—	32	0.3	0.042	—	—
—	—	43	0.6	0.113	—	—
—	—	48	0.6	0.136	—	—
—	—	35	0.3	0.056	—	—
—	—	35	0.3	0.083	—	—
NA49/22	24	37	0.3	0.056	0.086	IRM222817
—	—	37	0.3	0.055	—	—
NA69/22	24	37	0.3	0.100	0.154	IRM222830
—	—	38	0.3	0.068	—	—
—	—	38	0.3	0.087	—	—

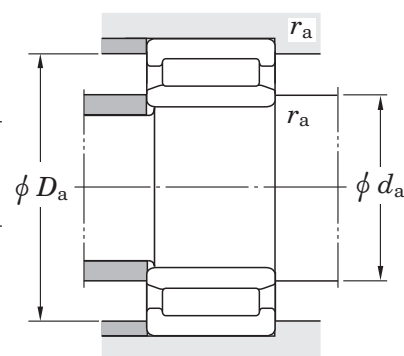

Machined ring needle roller bearings

F_w 29 ~ 37 mm

Without inner ring

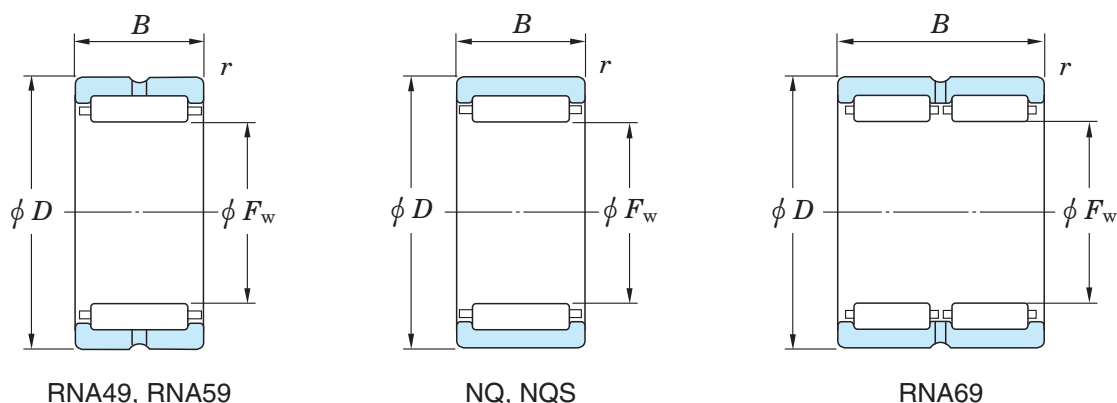

F_w	Boundary dimensions (mm)					Basic load ratings (kN)		Limiting speeds ¹⁾ (min ⁻¹)	Bearing No.
	d	D	B	B_1	$r_{min.}$	C_r	C_{0r}	Oil lub.	Without inner ring
29	25	38	15	—	0.6	14.6	22.6	16 000	—
	—	38	20	—	0.6	20.4	34.8	16 000	NQ29/20
	25	38	30	—	0.3	28.9	54.3	16 000	NQ29/30
30	—	40	20	—	0.3	23.7	37.5	15 000	NQ30/20
	—	40	30	—	0.3	33.5	58.5	15 000	NQ30/30
	25	42	17	18	0.3	18.4	22.4	6 600	—
	25	42	17	—	0.3	18.6	27.4	15 000	RNA4905
	25	42	17	—	0.3	24.2	31.7	15 000	RNA4905R
	25	42	23	—	0.3	31.7	44.9	15 000	RNA5905
	—	42	30	—	0.6	40.1	60.7	15 000	NQ304230
	25	42	30	—	0.3	40.1	60.7	15 000	RNA6905
	25	44	25	25.5	0.3	36.0	48.8	14 000	—
32	28	42	20	—	0.3	24.3	39.4	14 000	NQ32/20
	28	42	30	—	0.3	34.4	61.6	14 000	NQ32/30
	28	45	17	—	0.3	25.0	33.8	14 000	RNA49/28R
	25	47	22	—	0.3	31.2	41.4	14 000	NQS32/22
35	—	45	14	—	0.6	16.9	29.0	13 000	NQ354514
	30	45	20	—	0.3	24.7	41.4	13 000	—
	30	47	17	18	0.3	19.5	25.3	5 700	—
	30	47	17	17	0.3	20.0	31.6	13 000	RNA4906D
	30	47	17	—	0.3	26.4	34.4	13 000	RNA4906R
	30	47	23	—	0.3	33.8	51.0	13 000	RNA5906
	—	47	30	—	0.3	42.7	69.0	13 000	RNA6906
	—	48	24	—	0.3	33.9	51.3	13 000	35NQ4824D
37	32	47	20	—	0.3	26.0	45.1	13 000	NQ37/20
	—	47	20	—	0.3	26.0	45.1	13 000	NQ37/20D

[Note] 1) Limiting speeds of bearing number NA49...UU indicates the value of sealed and grease lubricated bearings.

[Remark] Limiting speed of grease lubrication should be kept to under 60 % of that for oil lubrication.

With inner ring

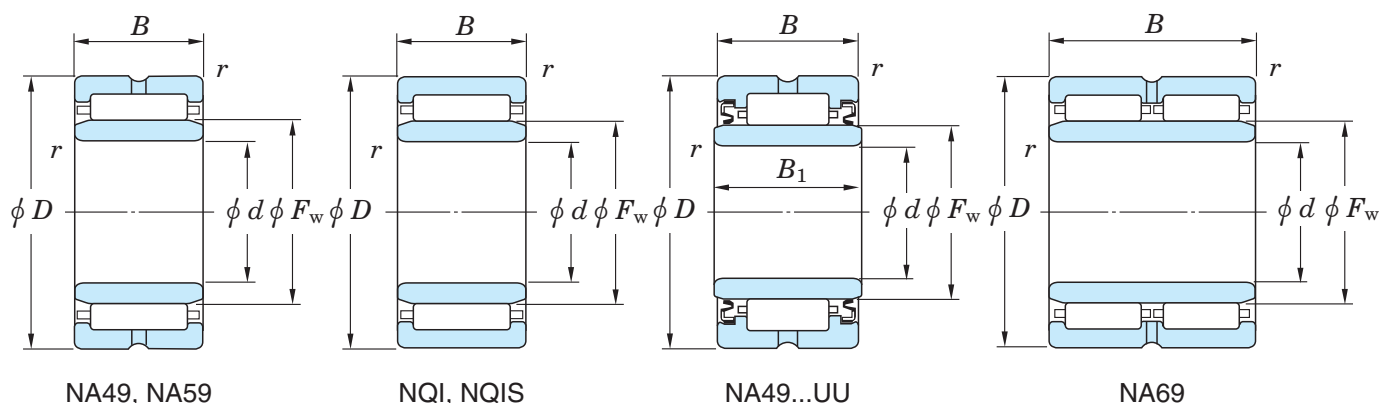

With inner ring	Mounting dimensions (mm)			(Refer.) Mass (kg)		(Refer.) Applicable inner ring No.
	d_a min.	D_a max.	r_a max.	Without inner ring	With inner ring	
NQI25/15	29	34	0.6	—	0.061	—
—	—	34	0.6	0.056	—	—
NQI25/30	27	36	0.3	0.085	0.125	—
—	—	38	0.3	0.066	—	—
—	—	38	0.3	0.099	—	—
NA4905UU	27	40	0.3	—	0.092	IRM253018
NA4905	27	40	0.3	0.065	0.096	IRM253017
NA4905R	27	40	0.3	0.065	0.092	IRM253017
NA5905	27	40	0.3	0.085	0.124	IRM253023
—	—	38	0.6	0.116	—	—
NA6905	27	40	0.3	0.112	0.162	IRM253030
25NQI4425A	27	42	0.3	—	0.161	—
NQI28/20	30	40	0.3	0.070	0.098	—
NQI28/30	30	40	0.3	0.104	0.141	—
NA49/28R	30	43	0.3	0.075	0.099	IRM283217
NQIS25/22	27	45	0.3	0.123	0.167	—
—	—	41	0.6	0.055	—	—
NQI30/20	32	43	0.3	—	0.108	—
NA4906UU	32	45	0.3	—	0.105	IRM303518
NA4906D	32	45	0.3	0.081	0.114	IRM303517D
NA4906R	32	45	0.3	0.070	0.103	IRM303517
NA5906	32	45	0.3	0.096	0.141	IRM303523
—	—	45	0.3	0.131	—	—
—	—	46	0.3	0.123	—	—
NQI32/20	34	45	0.3	0.079	0.114	—
—	—	45	0.3	0.079	—	—

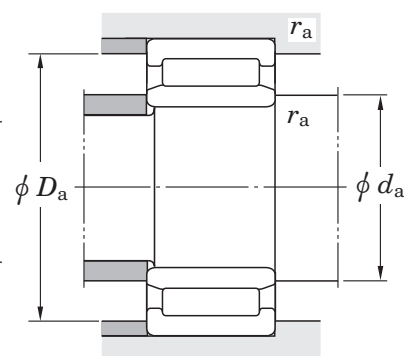

Machined ring needle roller bearings

F_w 38 ~ 48 mm

Without inner ring

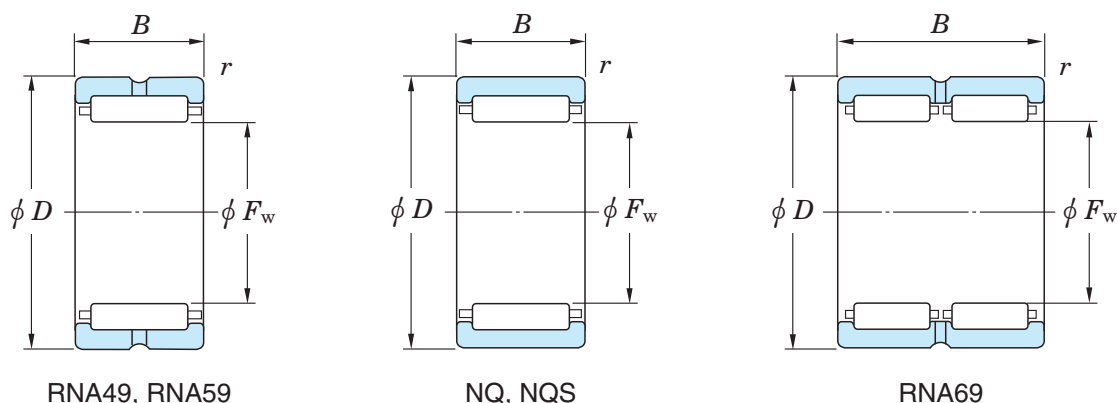

F_w	Boundary dimensions (mm)					Basic load ratings (kN)		Limiting speeds ¹⁾ (min ⁻¹)	Bearing No. Without inner ring
	d	D	B	B_1	$r_{min.}$	C_r	C_{0r}	Oil lub.	
38	—	47	20	—	0.3	23.6	45.8	12 000	38NQ4720 38NQ5235
	—	52	35	—	1	49.3	84.7	12 000	
40	—	48	20	—	0.3	20.9	39.8	12 000	NQ404820 NQ40/15AD NQ40/20 NQ40/30 RNA49/32R-1 40NQ5230
	—	50	15	—	0.3	21.0	35.1	12 000	
	35	50	20	—	0.3	27.2	48.8	12 000	
	35	50	30	—	0.3	39.8	79.8	12 000	
	—	52	20	—	0.6	31.9	49.3	11 000	
	—	52	30	—	0.6	47.0	81.0	11 000	
42	—	52	20	—	0.6	28.6	53.3	11 000	NQ425220D — RNA4907 RNA4907R RNA5907 RNA6907
	35	55	20	21	0.6	29.0	40.9	4 700	
	35	55	20	—	0.6	26.9	49.0	11 000	
	35	55	20	—	0.6	35.1	52.2	11 000	
	35	55	27	—	0.6	42.9	67.6	11 000	
	35	55	36	—	0.6	51.4	85.1	11 000	
43	38	53	30	30	0.6	41.3	85.9	10 000	—
45	—	55	20	—	0.6	27.9	52.7	10 000	NQ45/20 NQ45/30 RNA49/38R-1
	40	55	30	—	0.6	40.9	86.1	10 000	
	—	58	20	—	0.6	36.0	55.0	10 000	
47	42	57	20	—	0.6	29.0	56.4	10 000	—
	42	57	30	—	0.6	44.0	96.1	10 000	—
48	40	62	22	23	0.6	35.7	51.7	4 100	— RNA4908 RNA4908R-2 RNA5908 RNA6908
	40	62	22	—	0.6	32.6	58.5	9 700	
	—	62	22	—	0.6	43.2	66.1	9 400	
	40	62	30	—	0.6	55.5	91.2	9 400	
	40	62	40	—	0.6	66.7	115.0	9 400	

[Note] 1) Limiting speeds of bearing number NA49...UU indicates the value of sealed and grease lubricated bearings.
[Remark] Limiting speed of grease lubrication should be kept to under 60 % of that for oil lubrication.

With inner ring

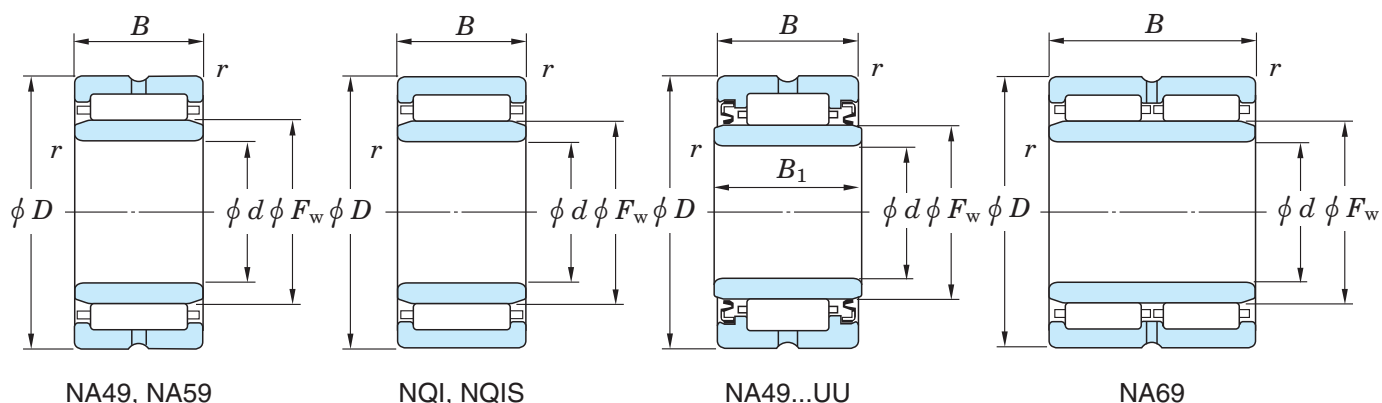

With inner ring	Mounting dimensions (mm)			(Refer.) Mass (kg)		(Refer.) Applicable inner ring No.
	d_a min.	D_a max.	r_a max.	Without inner ring	With inner ring	
—	—	45	0.3	0.073	—	—
—	—	47	1	0.203	—	—
—	—	46	0.3	0.064	—	—
—	—	48	0.3	0.063	—	—
NQI35/20	37	48	0.3	0.085	0.129	—
NQI35/30	37	48	0.3	0.120	0.192	—
—	—	48	0.6	0.098	—	—
—	—	48	0.6	0.148	—	—
—	—	48	0.6	0.087	—	—
NA4907UU	39	51	0.6	—	0.173	IRM354221
NA4907	39	51	0.6	0.122	0.186	IRM354220
NA4907R	39	51	0.6	0.104	0.168	IRM354220
NA5907	39	51	0.6	0.138	0.225	IRM354227
NA6907	39	51	0.6	0.182	0.297	IRM354236
NQI38/30	—	51	0.6	—	0.205	—
—	—	51	0.6	0.100	—	—
NQI40/30	44	51	0.6	0.138	0.214	—
—	—	54	0.6	0.116	—	—
NQI42/20	46	53	0.6	—	0.143	—
NQI42/30	46	53	0.6	—	0.219	—
NA4908UU	44	58	0.6	—	0.235	IRM404823
NA4908	44	58	0.6	0.157	0.249	IRM404822
—	—	58	0.6	0.142	—	—
NA5908	44	58	0.6	0.187	0.313	IRM404830
NA6908	44	58	0.6	0.256	0.415	IRM404840

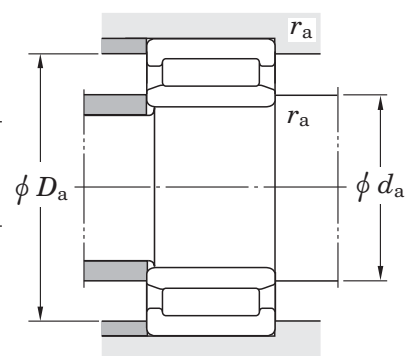

Machined ring needle roller bearings

F_w 50 ~ 63 mm

Without inner ring

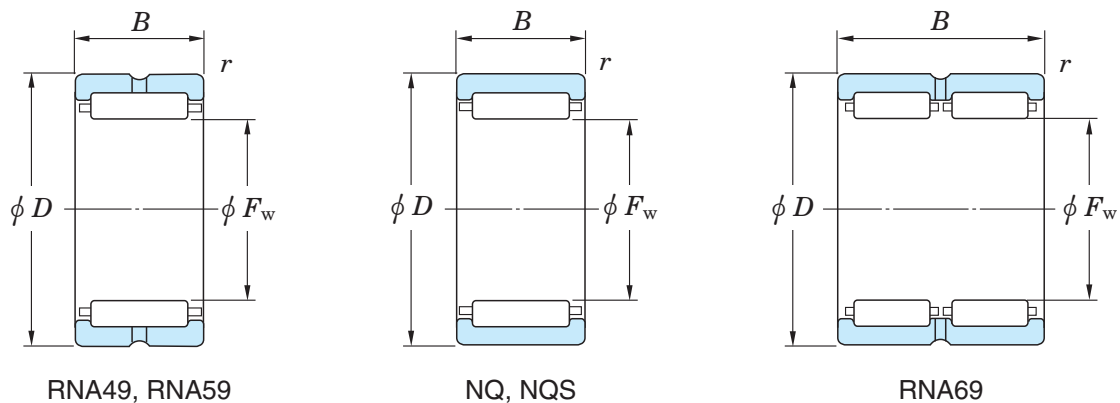

F_w	Boundary dimensions (mm)					Basic load ratings (kN)		Limiting speeds ¹⁾ (min ⁻¹)	Bearing No.
	d	D	B	B_1	$r_{min.}$	C_r	C_{0r}	Oil lub.	Without inner ring
50	—	62	20	—	0.6	24.8	46.0	9 400	NQ50/20A
	45	62	25	—	0.6	41.9	82.5	9 300	—
	45	62	35	—	0.6	58.2	126.0	9 300	—
	—	65	25	—	0.6	48.3	77.8	9 100	NQ506525
52	45	68	22	23	0.6	37.7	56.8	3 800	—
	45	68	22	—	0.6	33.2	61.9	9 000	RNA4909
	45	68	22	—	0.6	45.8	72.9	8 800	RNA4909R
	45	68	30	—	0.6	58.9	101.0	8 800	RNA5909
	45	68	40	—	0.6	70.7	127.0	8 800	RNA6909
53	—	68	24.5	—	0.6	47.1	81.7	8 700	NQ536825A
55	—	67	20	—	0.6	24.1	46.2	8 600	55NQ6720A
	50	68	25	—	0.6	47.4	90.4	8 500	—
	—	70	22	—	0.6	46.9	76.5	8 300	RNA49/48R
	—	72	14	—	0.6	12.5	19.6	8 600	55NQ7214
	45	72	22	—	0.6	44.6	71.6	8 300	NQS55/22
58	50	72	22	—	0.6	35.7	70.6	8 100	RNA4910
	50	72	22	—	0.6	48.0	80.0	7 900	RNA4910R
	50	72	30	—	0.6	61.6	110.0	7 900	RNA5910
	50	72	40	—	0.6	74.0	140.0	7 900	RNA6910
60	—	72	25	—	0.6	45.4	97.3	7 900	NQ60/25
	—	75	22	—	0.6	49.1	83.4	7 700	RNA49/52R
63	55	80	25	—	1	44.4	87.2	7 500	RNA4911
	55	80	25	—	1	58.4	99.0	7 300	RNA4911R
	55	80	34	—	1	75.6	138.0	7 300	RNA5911
	55	80	45	—	1	86.7	165.0	7 300	RNA6911

[Note] 1) Limiting speeds of bearing number NA49...UU indicates the value of sealed and grease lubricated bearings.

[Remark] Limiting speed of grease lubrication should be kept to under 60 % of that for oil lubrication.

With inner ring

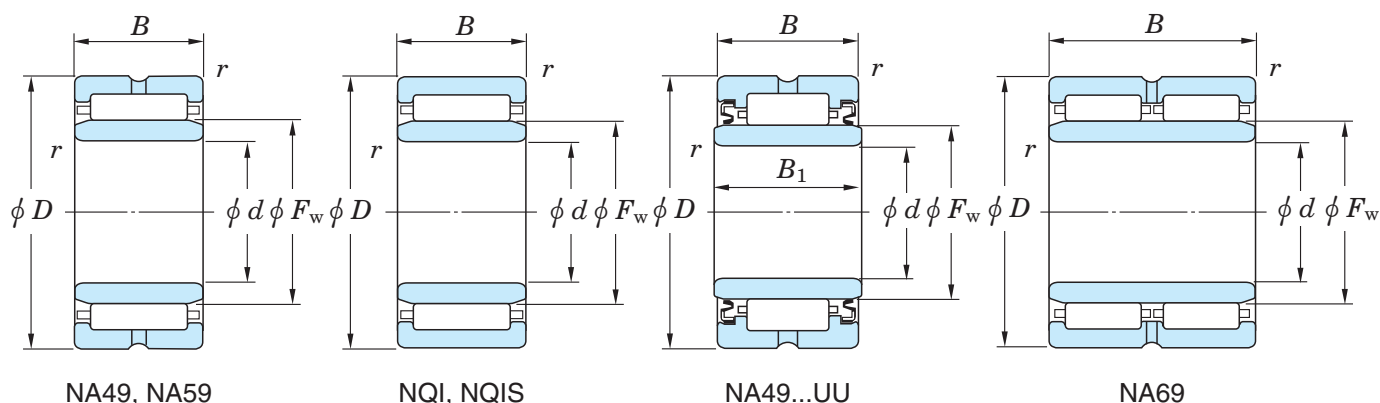

With inner ring	Mounting dimensions (mm)			(Refer.) Mass (kg)		(Refer.) Applicable inner ring No.
	d_a min.	D_a max.	r_a max.	Without inner ring	With inner ring	
—	—	58	0.6	0.126	—	—
NQI45/25	49	58	0.6	—	0.223	—
NQI45/35	49	58	0.6	—	0.316	—
—	—	61	0.6	0.190	—	—
NA4909UU	49	64	0.6	—	0.285	IRM455223
NA4909	49	64	0.6	0.205	0.294	IRM455222
NA4909R	49	64	0.6	0.185	0.274	IRM455222
NA5909	49	64	0.6	0.252	0.365	IRM455230
NA6909	49	64	0.6	0.334	0.496	IRM455240
—	—	64	0.6	0.207	—	—
—	—	63	0.6	0.136	—	—
NQI50/25	54	64	0.6	—	0.255	—
—	—	66	0.6	0.174	—	—
—	—	68	0.6	0.149	—	—
NQIS45/22	49	68	0.6	0.210	0.341	—
NA4910	54	68	0.6	0.191	0.298	IRM505822
NA4910R	54	68	0.6	0.172	0.276	IRM505822
NA5910	54	68	0.6	0.221	0.375	IRM505830
NA6910	54	68	0.6	0.291	0.497	IRM505840
—	—	68	0.6	0.164	—	—
—	—	71	0.6	0.188	—	—
NA4911	60	75	1	0.287	0.428	IRM556325
NA4911R	60	75	1	0.260	0.401	IRM556325
NA5911	60	75	1	0.354	0.546	IRM556334
NA6911	60	75	1	0.458	0.711	IRM556345

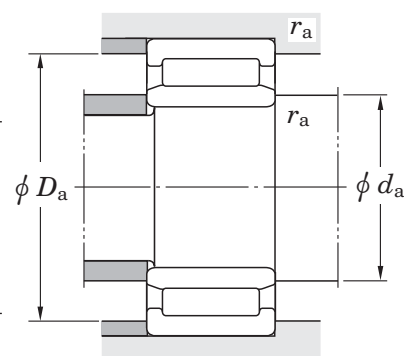

Machined ring needle roller bearings

F_w 65 ~ 105 mm

Without inner ring

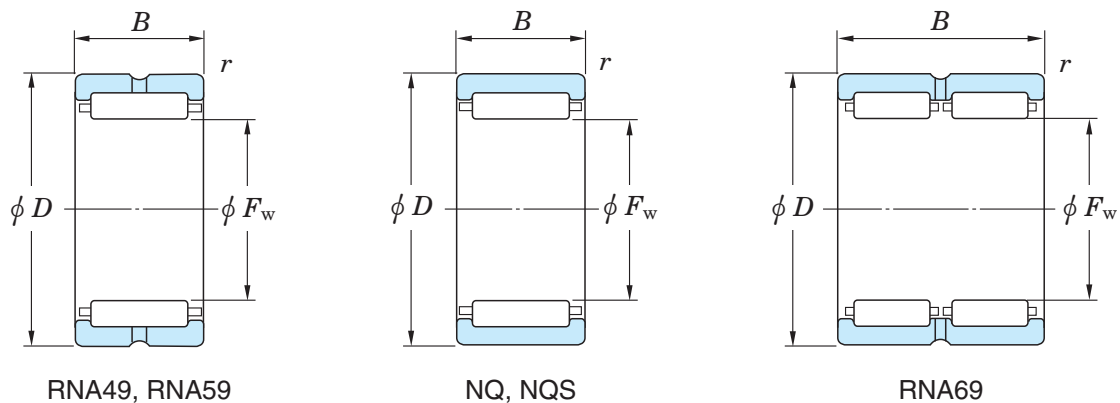

F_w	Boundary dimensions (mm)					Basic load ratings (kN)		Limiting speeds ¹⁾ (min ⁻¹)	Bearing No. Without inner ring
	d	D	B	B_1	$r_{min.}$	C_r	C_{0r}	Oil lub.	
65	—	82	25	—	1	59.9	103.0	7 100	RNA49/58R
68	60	85	25	—	1	45.8	93.3	6 900	RNA4912 RNA5912
	60	85	34	—	1	79.2	150.0	6 800	
70	—	88	25	—	1	64.5	109.0	6 600	RNA49/62
72	65	90	25	—	1	66.1	114.0	6 400	RNA4913 RNA5913 RNA6913
	65	90	34	—	1	85.4	158.0	6 400	
	65	90	45	—	1	98.4	190.0	6 400	
75	—	95	30	—	1	82.3	145.0	6 100	RNA49/68
80	70	100	30	—	1	86.4	157.0	5 700	RNA4914 RNA5914 RNA6914
	70	100	40	—	1	107.0	207.0	5 700	
	70	100	54	—	1	132.0	271.0	5 700	
85	75	105	30	—	1	88.0	164.0	5 400	RNA4915 RNA5915 RNA6915
	75	105	40	—	1	109.0	216.0	5 400	
	75	105	54	—	1	135.0	283.0	5 400	
90	80	110	30	—	1	91.6	176.0	5 100	RNA4916 RNA5916 RNA6916
	80	110	40	—	1	114.0	232.0	5 100	
	80	110	54	—	1	140.0	304.0	5 100	
95	—	115	30	—	1.1	92.8	183.0	4 900	RNA49/82
100	85	120	35	—	1.1	110.0	230.0	4 600	RNA4917 RNA5917 RNA6917
	85	120	46	—	1.1	126.0	293.0	4 700	
	85	120	63	—	1.1	165.0	390.0	4 600	
105	90	125	35	—	1.1	111.0	238.0	4 400	RNA4918 RNA5918 RNA6918
	90	125	46	—	1.1	137.0	311.0	4 400	
	90	125	63	—	1.1	167.0	403.0	4 400	

[Note] 1) Limiting speeds of bearing number NA49...UU indicates the value of sealed and grease lubricated bearings.
[Remark] Limiting speed of grease lubrication should be kept to under 60 % of that for oil lubrication.

With inner ring

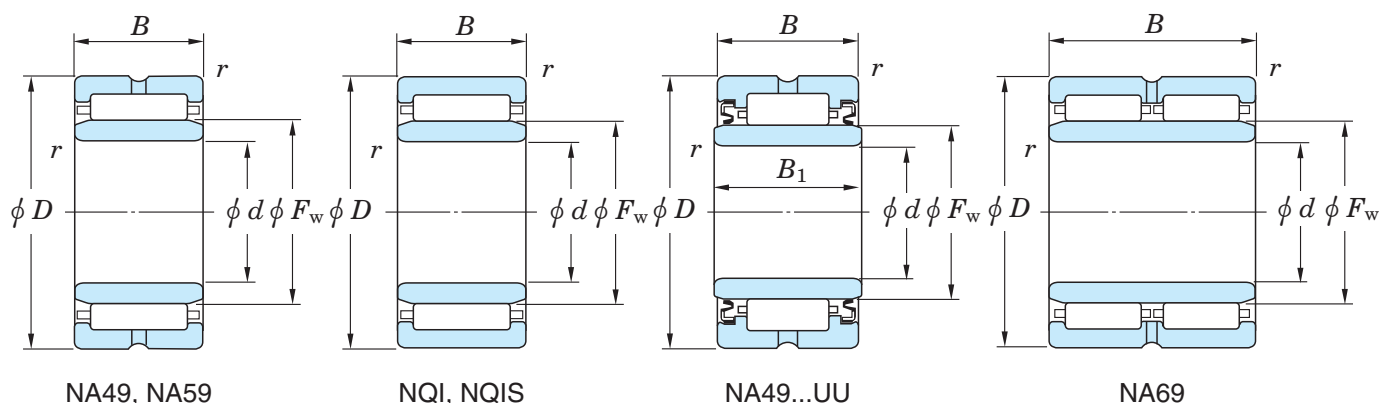

With inner ring	Mounting dimensions (mm)			(Refer.) Mass (kg)		(Refer.) Applicable inner ring No.
	d_a min.	D_a max.	r_a max.	Without inner ring	With inner ring	
—	—	77	1	0.277	—	—
NA4912 NA5912	65	80	1	0.310	0.459	IRM606825 IRM606834
—	—	83	1	0.298	—	—
NA4913 NA5913 NA6913	70	85	1	0.307	0.450	IRM657225
	70	85	1	0.419	0.613	IRM657234
	70	85	1	0.541	0.798	IRM657245
—	—	90	1	0.437	—	—
NA4914 NA5914 NA6914	75	95	1	0.483	0.733	IRM708030
	75	95	1	0.615	0.973	IRM708040
	75	95	1	0.895	1.37	IRM708054
NA4915 NA5915 NA6915	80	100	1	0.507	0.773	IRM758530
	80	100	1	0.644	1.03	IRM758540
	80	100	1	0.866	1.44	IRM758554
NA4916 NA5916 NA6916	85	105	1	0.540	0.819	IRM809030
	85	105	1	0.681	1.09	IRM809040
	85	105	1	0.916	1.46	IRM809054
—	—	108.5	1	0.537	—	—
NA4917 NA5917 NA6917	91.5	113.5	1	0.669	1.25	IRM8510035
	91.5	113.5	1	0.952	1.65	IRM8510046
	91.5	113.5	1	1.17	2.29	IRM8510063
NA4918 NA5918 NA6918	96.5	118.5	1	0.695	1.31	IRM9010535
	96.5	118.5	1	0.898	1.70	IRM9010546
	96.5	118.5	1	1.21	2.31	IRM9010563

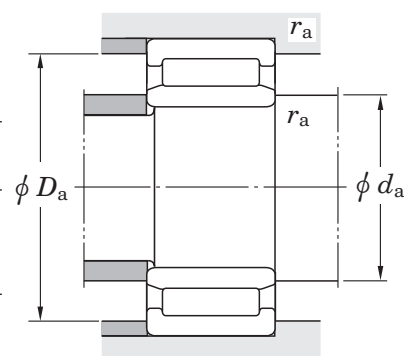

Machined ring needle roller bearings

F_w 110 ~ 160 mm

Without inner ring

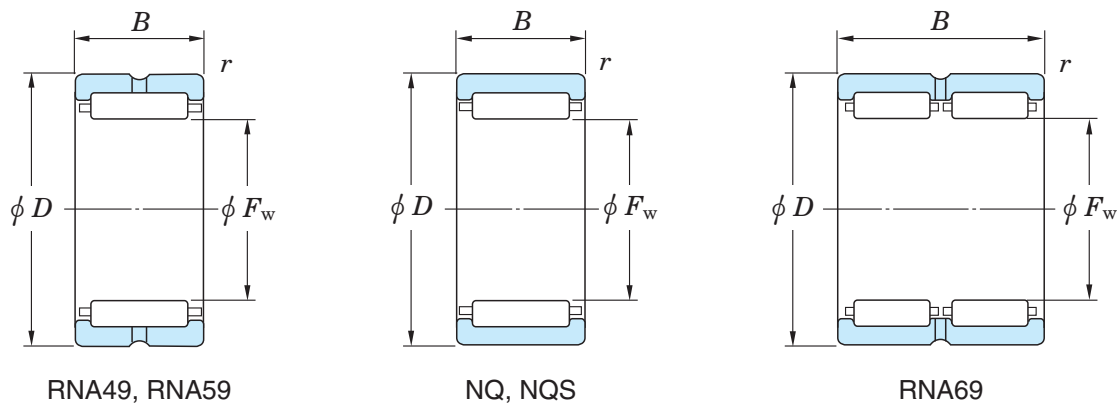

F_w	Boundary dimensions (mm)					Basic load ratings (kN)		Limiting speeds ¹⁾ (min ⁻¹)	Bearing No. Without inner ring
	d	D	B	B_1	$r_{min.}$	C_r	C_{0r}	Oil lub.	
110	95	130	35	—	1.1	115.0	253.0	4 200	RNA4919 RNA5919 RNA6919
	95	130	46	—	1.1	141.0	331.0	4 200	
	95	130	63	—	1.1	173.0	428.0	4 200	
115	100	140	40	—	1.1	144.0	296.0	4 000	RNA4920 RNA5920
	100	140	54	—	1.1	189.0	418.0	4 000	
125	110	150	40	—	1.1	149.0	317.0	3 700	RNA4922 RNA5922
	110	150	54	—	1.1	195.0	448.0	3 700	
135	120	165	45	—	1.1	192.0	398.0	3 400	RNA4924 RNA5924
	120	165	60	—	1.1	244.0	564.0	3 400	
150	130	180	50	—	1.5	225.0	508.0	3 000	RNA4926 RNA5926
	130	180	67	—	1.5	274.0	655.0	3 000	
160	140	190	50	—	1.5	232.0	540.0	2 800	RNA4928 RNA5928
	140	190	67	—	1.5	283.0	696.0	2 800	

[Note] 1) Limiting speeds of bearing number NA49...UU indicates the value of sealed and grease lubricated bearings.

[Remark] Limiting speed of grease lubrication should be kept to unber 60 % of that for oil lubrication.

With inner ring

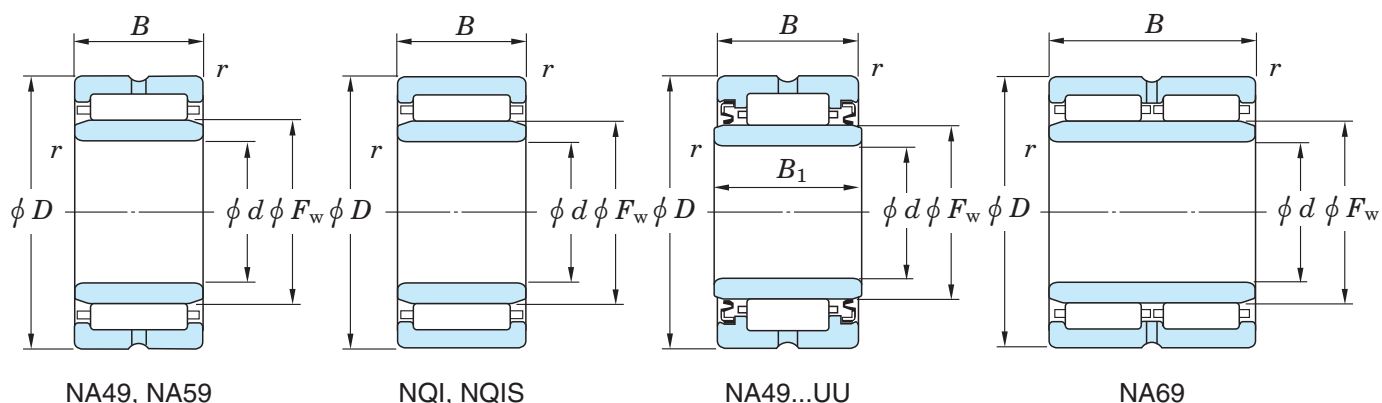

With inner ring	Mounting dimensions (mm)			(Refer.) Mass (kg)		(Refer.) Applicable inner ring No.
	d_a min.	D_a max.	r_a max.	Without inner ring	With inner ring	
NA4919	101.5	123.5	1	0.728	1.37	IRM9511035
NA5919	101.5	123.5	1	0.940	1.78	IRM9511046
NA6919	101.5	123.5	1	1.27	2.43	IRM9511063
NA4920	106.5	133.5	1	1.160	1.86	IRM10011540
NA5920	106.5	133.5	1	1.49	2.53	IRM10011554
NA4922	116.5	143.5	1	1.17	2.01	IRM11012540
NA5922	116.5	143.5	1	1.690	2.74	IRM11012554
NA4924	126.5	158.5	1	1.75	2.78	IRM12013545
NA5924	126.5	158.5	1	2.43	3.80	IRM12013560
NA4926	138	172	1.5	2.21	3.83	IRM13015050
NA5926	138	172	1.5	3.000	5.09	IRM13015067
NA4928	148	182	1.5	2.350	4.08	IRM14016050
NA5928	148	182	1.5	3.02	5.42	IRM14016067

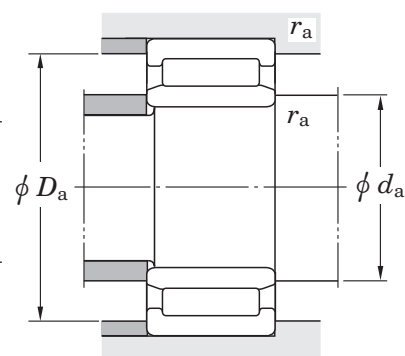

Needle roller thrust bearings

$d (d_1)$ 10 ~ 22.2 mm

Separable type

Needle roller and cage thrust assembly

Race

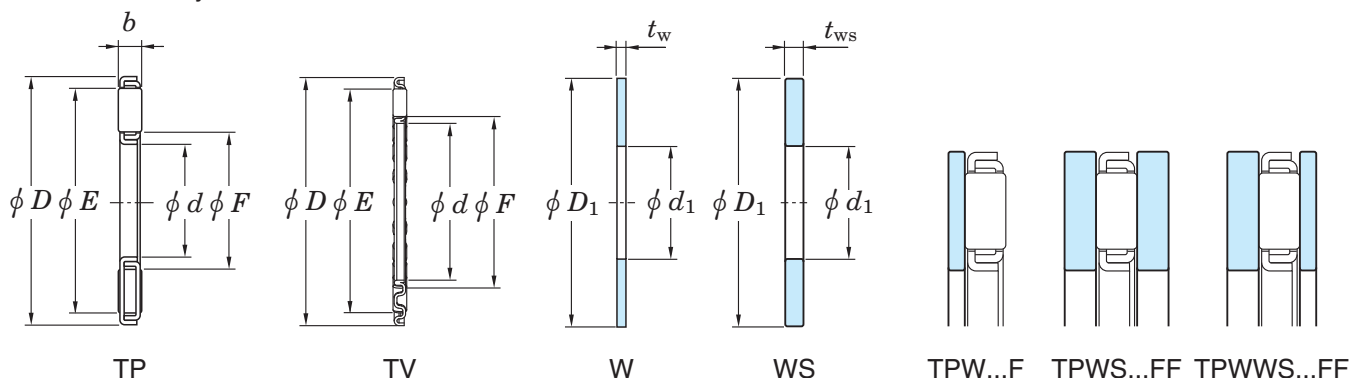

Boundary dimensions (mm)									Basic load ratings (kN)		Limiting speeds (min ⁻¹)	
d	d_1	D	D_1	b	t_w	t_J	t_{ws}	t_L	C_a	C_{0a}	Oil lub.	
10	10	24	24	2	1.0	—	2	—	6.35	18.3	12 000	
	—	23	—	2	—	—	—	—	8	24	12 000	
12	—	24	—	2	—	—	—	—	3.75	9	12 000	
	12	25.8	26	2	1.0	—	2	—	6.55	19.79	11 000	
	12	26	26	2	1.0	—	2	—	8.6	27.5	11 000	
14	14	27	27	2	1	—	2.75	—	6.55	19.8	11 000	
15	15	32.3	32	2	1.0	—	—	—	11	42.1	10 000	
	15	28	28	2	1.0	—	2	—	9.85	34.3	11 000	
16	16	29	29	2	1.5	—	2.75	—	9.15	31.4	11 000	
17	17	30	30	2	0.8	—	2.75	—	9.40	32.9	10 000	
	17	40	40	2.5	—	—	3	—	17.9	69.3	8 000	
	17	34	34	2.5	—	—	2.155	—	14.1	49.5	8 700	
18	18	31	31	2	1.0	—	2	—	9.65	34.4	10 200	
—	18.1	31.6	31	2	—	—	—	0.8	7.45	25.2	10 000	
—	18.75	—	39.7	1.984	—	0.8	—	0.8	9.8	37.4	9 000	
19.6	21	—	35.9	2	—	0.8	—	—	6	18.7	9 400	
20	20	35	35	2	1	—	2.75	—	13.2	53.6	9 600	
20.9	—	32	—	2	—	—	—	—	8.4	29.7	10 000	
21.9	—	34	—	2	—	—	—	—	8.05	28.6	9 700	
22	22	37	37	2	1	—	2.75	—	12.6	51.7	9 300	
	—	22	41	41	2	—	—	0.8	13.2	56.8	8 800	
22.2	—	36.1	—	1.984	—	—	—	—	9.95	38.2	9 500	

Non-separable type

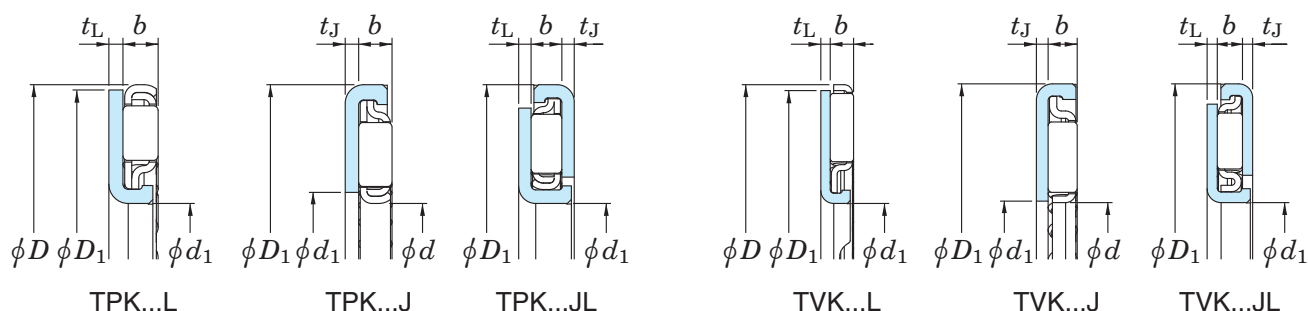

	Bearing No.				Dimensions (mm)		(Refer.) Mass (g)			
	Needle roller and cage thrust ass'y		Thin plate race	Thick plate race	E	F	TP		(W)	(WS)
	Separable type	Non-separable type	(pressed)	(machined)			[TP]	[TV]		
	TP1024-1	—	W1024F	WS1024F	15.2	21.8	3.5	—	2.9	5.8
	TV1023	—	—	—	12.6	21.8	2.5	—	—	—
	TP1224	—	—	—	14.1	22.1	3.0	—	—	—
	TP1226B	—	W1226F	WS1226F	17.3	23.5	3.6	—	3.3	6.6
	TV1226	—	W1226F	WS1226BF	14.6	23.8	3.8	—	3.3	6.6
	TP1427	—	W1427F	WS1427F	24.5	16.5	3.6	—	3.2	9.0
	TP1532-1	—	W1532F	—	22.3	30.3	6.1	—	4.6	—
	TV1528	—	W1528F	WS1528F	17.6	26.8	4.1	—	3.4	6.8
	TP1629	—	W1629AF	WS1629F	26.5	18.5	4.4	—	5.4	9.9
	TP1730	—	W1730F	WS1730F	27.5	19.5	4.4	—	3.0	10
	TP1740	—	—	WS1740F	36.5	22.7	11	—	—	24
	TV1734	—	—	WS1734-2F	21.1	32.5	8.2	—	—	11
	TP1831	—	W1831F	WS1831F	20.4	28.4	5.0	—	3.9	7.8
	—	TPK1832L	—	—	22.8	29.4	—	8	—	—
	—	TVK1940JL	—	—	25	34.2	—	17	—	—
	—	TPK2036J-1	—	—	21.8	28	—	10	—	—
	TP2035-1	—	W2035F	WS2035F	32.5	22.9	5.9	—	5.1	14
	TP2132D	—	—	—	23.5	29.7	4.6	—	—	—
	TP2234	—	—	—	25	31.2	5.1	—	—	—
	TP2237-1	—	W2237F	WS2237F	34.5	22.9	6.4	—	5.4	15
	—	TPK2241L	—	—	28	38	—	15	—	—
	TP2236A-1	—	—	—	25.3	33.3	6.1	—	—	—

Needle roller thrust bearings

$d (d_1)$ 22.7 ~ 32.9 mm

Separable type

Needle roller and cage thrust assembly

Race

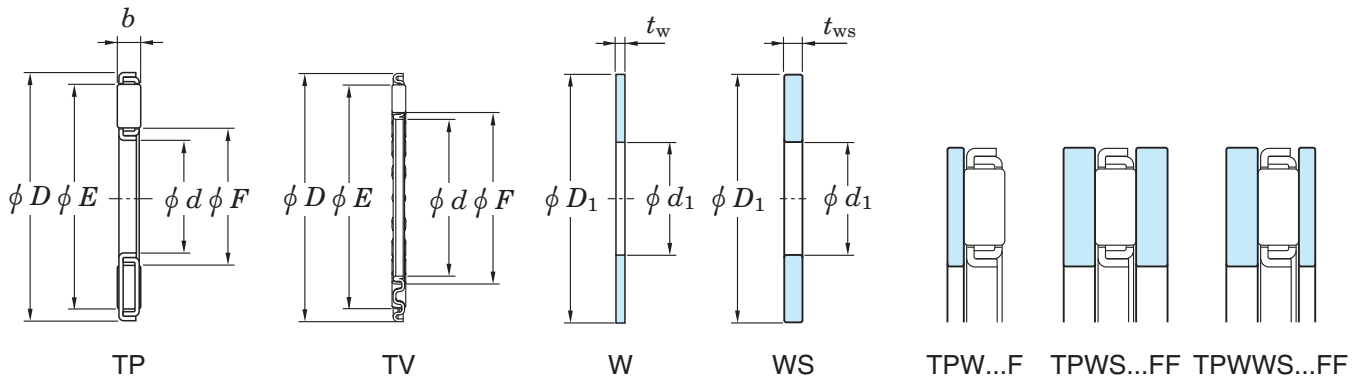

Boundary dimensions (mm)									Basic load ratings (kN)		Limiting speeds (min ⁻¹)	
d	d_1	D	D_1	b	t_w	t_J	t_{ws}	t_L	C_a	C_{0a}	Oil lub.	
22.7	22	—	35.1	2	—	0.8	—	—	8.3	29.7	9 500	
22.8	22	—	37.95	1.984	—	0.8	—	—	10.6	40.9	9 200	
25	25	42	42	2	1.0	—	3	—	14.8	66.2	8 700	
	25	—	39.5	2.5	—	0.8	—	—	14	51.5	8 100	
25.8	26	—	42	1.984	—	0.8	—	—	12.8	54.4	8 800	
26	—	38.66	—	2	—	—	—	—	10.4	41.2	9 100	
	26	—	43.4	1.984	—	0.8	—	0.8	11.5	49	8 600	
28	—	41	—	2	—	—	—	—	9.4	37.4	8 800	
	28	45	45	2	0.8	—	3	—	15.1	70.3	8 400	
	28	—	42.6	2	—	0.8	—	—	9.4	37.4	8 700	
28.5	28.5	46.15	46.15	2	0.8	—	—	—	12.1	52.4	8 300	
28.9	—	42	—	1.984	—	—	—	—	11.7	50.4	8 800	
—	29	47.21	47	2	—	—	—	1	15.9	76	8 300	
	29	48.4	49	3	—	—	—	0.8	21.8	87.4	6 600	
30	30	47	47	2	1.0	—	2	—	16.2	78.6	8 300	
—	30.1	45.5	45.5	1.984	—	—	—	0.8	12.4	55.9	8 400	
	30.1	—	47.3	1.984	—	0.8	—	0.8	12.4	55.9	8 300	
—	30.7	—	46.02	1.984	—	0.8	—	0.8	12.5	56.2	8 400	
	30.7	—	46.43	1.984	—	1	—	0.8	12.5	56.2	8 300	
—	31.85	45.1	45.2	1.984	—	—	—	0.8	12.1	54.7	8 400	
32	32	49	49	2	1	—	3	—	17.3	86.2	8 100	
—	32.9	53.1	53.1	1.984	—	—	—	0.8	18.4	97.2	7 800	

Non-separable type

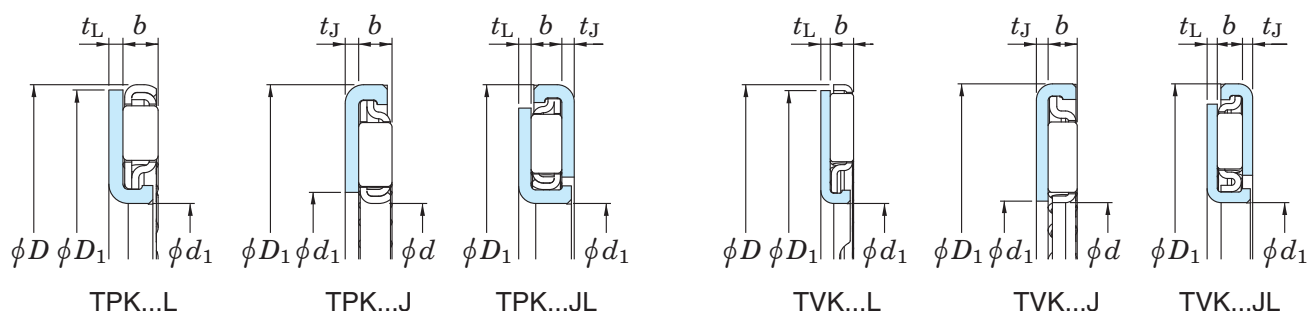

	Bearing No.				Dimensions (mm)		(Refer.) Mass (g)			
	Needle roller and cage thrust ass'y		Thin plate race	Thick plate race	E	F	TP		(W)	(WS)
	Separable type	Non-separable type	(pressed)	(machined)			(TP)	(TV)		
	—	TPK2235J	—	—	25	31.2	—	9.1	—	—
	—	TVK2238J	—	—	24	33.2	—	11	—	—
	TP2542	—	W2542F	WS2542KF	28.6	39.2	8.6	—	7	21
	—	TVK2540J	—	—	26.2	35.4	—	12.4	—	—
	—	TVK2642J	—	—	27	37	—	13	—	—
	TV2639-1	—	—	—	28.2	37.4	5.5	—	—	—
	—	TPK2643JL	—	—	30.6	38.6	—	19	—	—
	TP2841C	—	—	—	31.5	37.7	6.7	—	—	—
	TP2845	—	W2845F	WS2845F	42.5	31.9	9.0	—	6.1	19
	—	TPK2843AJ	—	—	31.5	37.7	—	13	—	—
	TP2946A	—	W2946AF	—	32.4	40.4	9.3	—	6.5	—
	TP2942A-1	—	—	—	31.6	39.6	7.2	—	—	—
	—	TVK2947L	—	—	34	45	—	18	—	—
	—	TVK2949L	—	—	35	47	—	22	—	—
	TP3047-1	—	W3047F	WS3047F	34	44.6	10	—	8.1	16.2
	—	TPK3046L	—	—	35	42.6	—	14	—	—
	—	TPK3047JL-1	—	—	35	42.6	—	21	—	—
	—	TPK3146JL-4	—	—	34.5	42.3	—	19	—	—
	—	TPK3146JL-5	—	—	34.5	42.3	—	21	—	—
	—	TVK3245L	—	—	36.2	44.2	—	12	—	—
	TP3249	—	W3249F	WS3249F	46.5	35.9	10	—	8.5	25
	—	TVK3353L	—	—	39.8	51.8	—	20	—	—

Needle roller thrust bearings

$d (d_1)$ 33.5 ~ 45 mm

Separable type

Needle roller and cage thrust assembly

Race

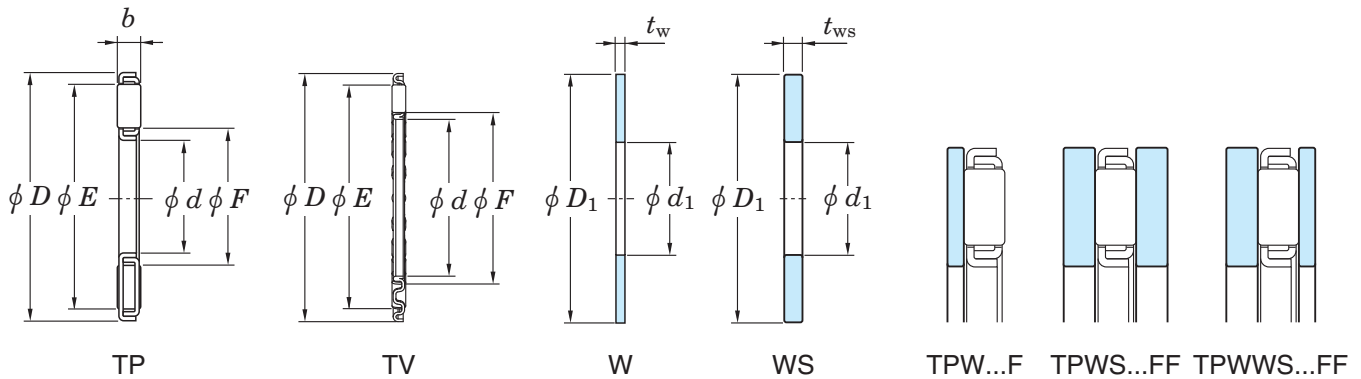

Boundary dimensions (mm)									Basic load ratings (kN)		Limiting speeds (min ⁻¹)	
d	d_1	D	D_1	b	t_w	t_J	t_{ws}	t_L	C_a	C_{0a}	Oil lub.	
33.5	—	45	—	2	—	—	—	—	8.5	34.3	8 400	
33.7	33.8	—	48.2	1.984	—	0.8	—	—	13.6	63	8 200	
—	34	—	51.4	2	—	0.8	—	0.8	12.6	58.1	7 900	
34.65	35	52	52	2	1.0	—	3	—	17.1	86.9	7 800	
	34.6	58.4	58.2	2	0.8	—	—	—	20.5	114	7 400	
	34.6	58.4	58.2	2	0.8	—	—	—	22.4	128	7 400	
—	37.4	57.3	57.3	1.984	—	—	—	0.8	19.3	106	7 500	
—	38	—	53	2	—	0.8	—	0.8	11.6	53.8	7 800	
—		—	58	3	—	0.8	—	1	24.9	91.5	6 100	
38.07	38	—	52	2	—	0.8	—	—	12	55.2	7 800	
38.15	38.15	55.29	55.29	1.984	0.8	—	3.0	—	19.9	108	7 600	
39.6	—	58.1	—	3	—	—	—	—	25.8	115	6 100	
40	40	60	60	3	1.0	—	2	—	23.5	103	6 000	
41	—	68	—	9	—	—	—	—	75.8	222	3 200	
42	—	62	—	3	—	—	—	—	17.5	71.4	5 900	
—	42.5	—	61.2	1.984	—	0.8	—	0.8	15.5	81.7	7 300	
—	43.45	—	61.2	1.984	—	0.8	—	0.8	14.6	74.9	7 300	
—		—	61.74	1.984	—	—	1.1	—	0.8	14.6	74.9	7 200
45	45.24	62.19	62.2	1.984	0.8	—	2	—	20.3	115	7 200	
	45	56	56	2	1.0	—	2	—	9	39.6	7 600	
	45	65	65	3	1.5	—	2	—	25.2	116	5 700	

Non-separable type

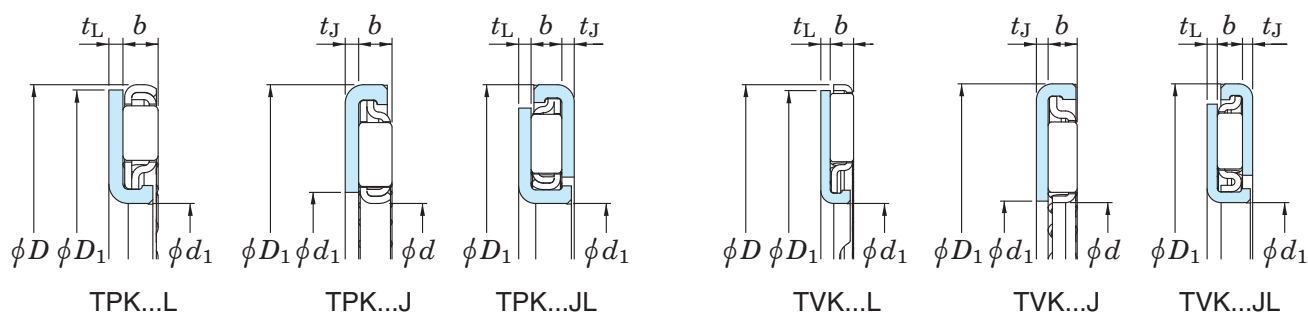

	Bearing No.				Dimensions (mm)		(Refer.) Mass (g)			
	Needle roller and cage thrust ass'y		Thin plate race	Thick plate race	<i>E</i>	<i>F</i>	〔 TP TV 〕	〔 TPK TVK 〕	(W)	(WS)
	Separable type	Non-separable type	(pressed)	(machined)						
	TP3445A	—	—	—	37	42.6	6.8	—	—	—
	—	TVK3448J-1	—	—	35	44.2	—	14	—	—
	—	TPK3451JL	—	—	38.6	46.6	—	23	—	—
	TP3552B	—	W3552F	WS3552AF	38.4	49	11	—	9.1	27
	TP3558	—	W3558F	—	44	56	16	—	11	—
	TP3558-1	—	W3558F	—	42	56	16	—	11	—
	—	TVK3757L	—	—	44	56	—	23	—	—
	—	TPK3853JL	—	—	42.4	49	—	22	—	—
	—	TPK3858JL	—	—	43.2	53.2	—	41	—	—
	—	TVK3852J-1	—	—	39.8	47.8	—	15	—	—
	TP3855A	—	W3855F	WS3855F	40.59	52.59	13	—	13	49
	TP4058-1	—	—	—	43.3	55.3	22	—	—	—
	TP4060	—	W4060F	WS4060F	44.4	56	23	—	12	24
	TP4168	—	—	—	45.4	63.8	104	—	—	—
	TP4262	—	—	—	47.8	56.4	23	—	—	—
	—	TVK4361JL-2	—	—	47.6	56.8	—	29	—	—
	—	TVK4361JL	—	—	47.6	56.8	—	29	—	—
	—	TVK4362JL	—	—	47.6	56.8	—	32	—	—
	TV4562	—	W4562F	WS4562AF	46.2	58.6	14	—	8.8	22
	TP4556	—	W4556F	WS4556F	47.5	53.7	8.4	—	6.8	13.6
	TP4565A	—	W4565AF	WS4565F	49.4	61	26	—	20	27

Needle roller thrust bearings

$d (d_1)$ 46.4 ~ 70.03 mm

Separable type

Needle roller and cage thrust assembly

Race

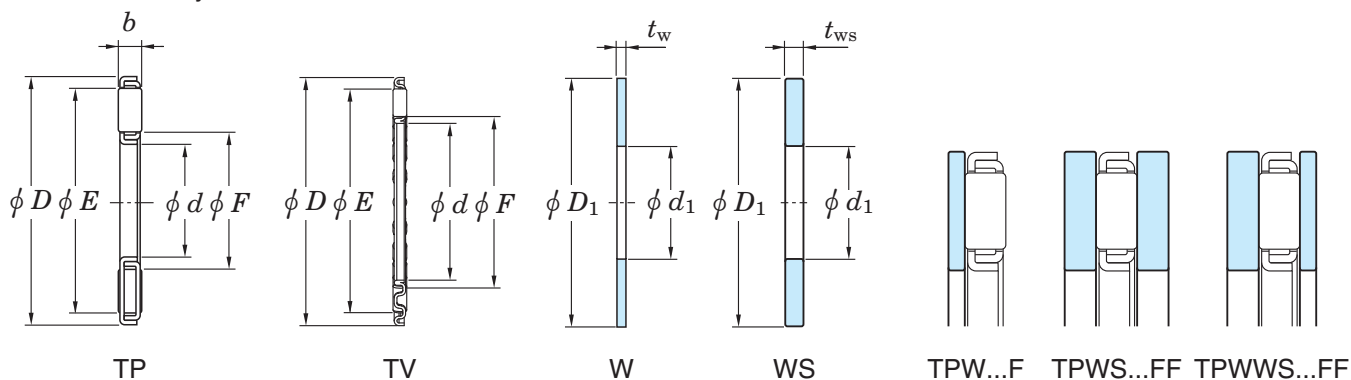

Boundary dimensions (mm)									Basic load ratings (kN)		Limiting speeds (min ⁻¹)	
d	d_1	D	D_1	b	t_w	t_J	t_{ws}	t_L	C_a	C_{0a}	Oil lub.	
46.4	—	68	—	3.5	—	—	—	—	38.4	182	5 200	
—	48.25	—	72	3	—	0.8	—	0.8	30.9	129	5 400	
49	49.1	70.65	71	1.984	0.8	—	1.84	—	18	105	6 800	
50	50	70	70	3	1.0	—	2	—	26.7	129	5 500	
52	—	72.6	—	1.984	—	—	—	—	26	169	6 700	
—	53.6	—	69.6	1.984	—	0.8	—	0.8	15.9	89.3	6 800	
—	53.6	—	70.18	1.984	—	1.1	—	0.8	15.9	89.3	6 800	
55	55	78	78	3	1	—	4	—	32.4	171	5 200	
55.48	56.8	—	69.6	1.984	—	0.8	—	—	15.9	89.3	6 800	
—	55.9	—	76	1.984	—	0.8	—	0.8	16.2	91.9	6 500	
—	55.9	—	76.6	1.984	—	1.1	—	0.8	16.2	91.9	6 500	
—	57	70.8	71	1.984	—	—	—	0.8	14.6	80.7	6 700	
60	60	85	85	3	1	—	5	—	38.3	218	5 000	
—	60.4	—	78	2	—	0.8	—	0.8	17.9	107	6 400	
62	—	80.25	—	2	—	—	—	—	23.3	151	6 300	
—	63	77.73	78	2	—	—	—	0.8	13.6	75.5	6 400	
65	65	90	90	3	1	—	5	—	40.1	236	4 900	
70	70	95	95	4	1	—	3	—	52.1	275	4 100	
70.03	—	92.37	—	3.175	—	—	—	—	33.4	181	4 700	

Non-separable type

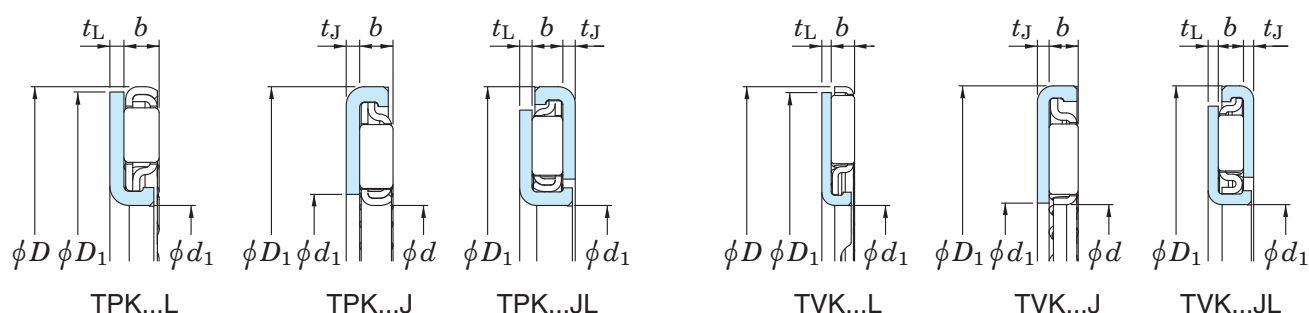

	Bearing No.				Dimensions (mm)		(Refer.) Mass (g)			
	Needle roller and cage thrust ass'y		Thin plate race (pressed)	Thick plate race (machined)	E	F	TP		(W)	(WS)
	Separable type	Non-separable type					TV	TPK TVK		
	TP4668-2	—	—	—	49.4	65	35	—	—	—
	—	TVK4872JL	—	—	54	66	—	56	—	—
	TV4971	—	W4971AF	WS4971F-1	58.4	68.4	17	—	13	30
	TP5070	—	W5070F	WS5070F	54.4	66	28	—	15	30
	TV5273	—	—	—	56	71.2	19	—	—	—
	—	TPK5470JL-3	—	—	57.4	65.2	—	32	—	—
	—	TPK5470JL-4	—	—	57.4	65.2	—	36	—	—
	TP5578	—	W5578F	WS5578F	60.4	74	33	—	19	75
	—	TPK5570J	—	—	57.4	65.2	—	20	—	—
	—	TVK5676JL	—	—	60.6	69.8	—	40	—	—
	—	TVK5677JL	—	—	60.6	69.8	—	41	—	—
	—	TVK5771L	—	—	61.8	69.8	—	20	—	—
	TP6085	—	W6085F	WS6085F	81	65.4	40	—	22	112
	—	TPK6078JL	—	—	65.6	73.6	—	38	—	—
	TP6280A	—	—	—	65.2	76.8	20	—	—	—
	—	TVK6378L	—	—	68	76	—	23	—	—
	TP6590	—	W6590F	WS6590F	86	70.4	43	—	24	119
	TP7095	—	W7095F	WS7095F	74.2	90.2	70	—	25	75
	TV7092A	—	—	—	75	87.4	34	—	—	—

Needle roller thrust bearings

$d (d_1)$ 71.9 ~ 100 mm

Separable type

Needle roller and cage thrust assembly

Race

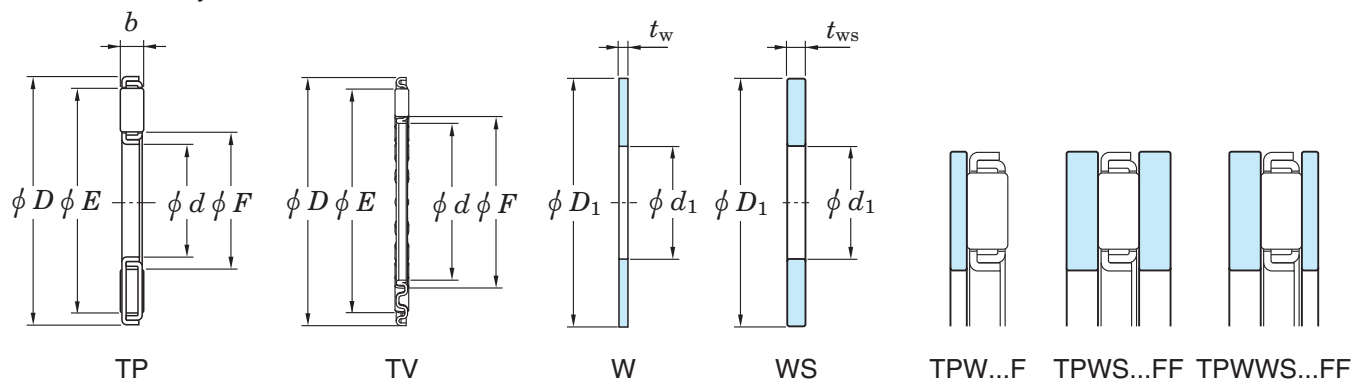

Boundary dimensions (mm)									Basic load ratings (kN)		Limiting speeds (min ⁻¹)	
d	d_1	D	D_1	b	t_w	t_J	t_{ws}	t_L	C_a	C_{0a}	Oil lub.	
—	71.9	85.6	85.5	2	—	0.8	—	—	14.1	82.4	6 100	
—	73.6	—	89.6	2	—	0.8	—	0.8	10	52.6	6 000	
75	75	100	100	4	2	—	5	—	46.7	243	4 000	
80	80	105	105	4	1	—	6	—	47.8	255	3 900	
82.68	—	114.3	—	9.525	—	—	—	—	117	453	2 400	
—	83.1	—	104	2	—	2	—	0.8	14.7	90	5 500	
85	85	110	110	4	1	—	6	—	48.9	266	3 800	
90	90	120	120	4	1	—	6	—	60.9	362	3 600	
100	100	135	135	4	1	—	6	—	76.3	503	3 400	

Non-separable type

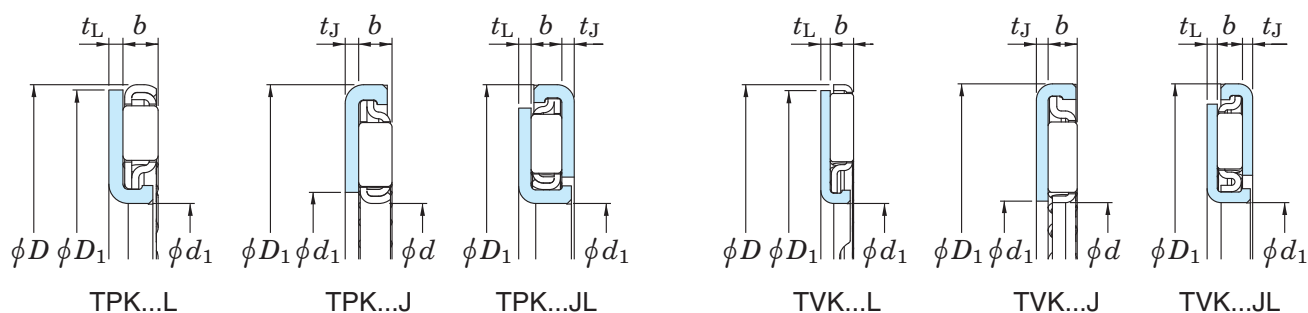

	Bearing No.				Dimensions (mm)		(Refer.) Mass (g)			
	Needle roller and cage thrust ass'y		Thin plate race (pressed)	Thick plate race (machined)	E	F	TP		(W)	(WS)
	Separable type	Non-separable type					[TP]	[TV]		
—	TPK7286L		—	—	76.5	83.1	—	27	—	—
—	TPK7490JL		—	—	78	84.6	—	41	—	—
TP75100	—	W75100F	WS75100F	95	79.4	63	—	54	135	
TP80105	—	W80105F	WS80105F	100	84.4	67	—	29	171	
TP83114	—	—	—	88.6	109	218	—	—	—	
—	TVK83104JL		—	—	88.8	96.8	—	77	—	—
TP85110	—	W85110F	WS85110F	105	89.4	70	—	30	180	
TP90120	—	W90120F	WS90120F	115	95.4	92	—	39	234	
TP100135	—	W100135F	WS100135F	130	106.4	122	—	51	304	

Stud type track rollers (cam followers) CM (full complement type)

D 16 ~ 90 mm

Without seals

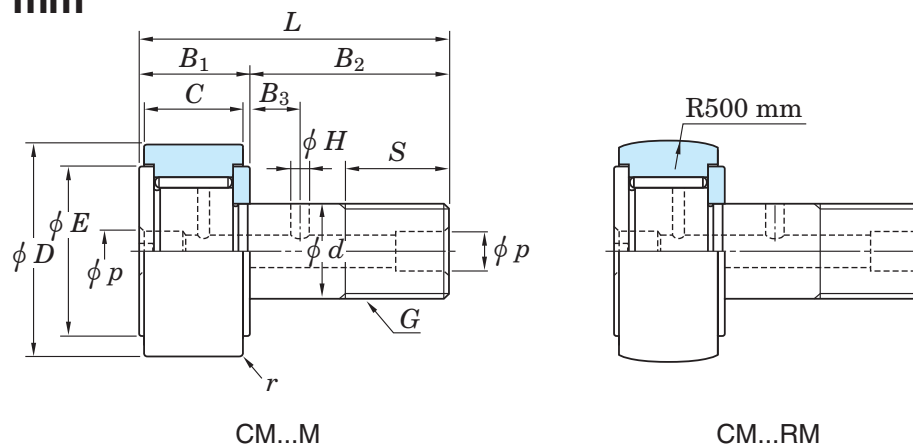

Outer ring			Boundary dimensions (mm)							Lubrication hole			Bearing No. Without seals	
D	C	$r_{\min.}$	d	L	B_1	B_2	E	Thread	S	B_3	H	p	Cylindrical outer ring	Crowned outer ring
16	11	0.3	6	28	12	16	12	M6×1	9	—	—	4 ¹⁾	CM6M	CM6RM
19	11	0.3	8	32	12	20	15	M8×1.25	11	—	—	4 ¹⁾	CM8M	CM8RM
22	12	0.5	10	36	13	23	17	M10×1.25	13	—	—	4	CM10M	CM10RM
26	12	0.5	10	36	13	23	17	M10×1.25	13	—	—	4	CM10-1M	CM10-1RM
30	14	1	12	40	15	25	22	M12×1.5	14	6	3	6	CM12M	CM12RM
32	14	1	12	40	15	25	22	M12×1.5	14	6	3	6	CM12-1M	CM12-1RM
35	18	1	16	52	19.5	32.5	27	M16×1.5	18	8	3	6	CM16M	CM16RM
40	20	1.5	18	58	21.5	36.5	32	M18×1.5	20	8	3	6	CM18M	CM18RM
47	24	1.5	20	66	25.5	40.5	36	M20×1.5	22	9	4	8	CM20M	CM20RM
52	24	1.5	20	66	25.5	40.5	36	M20×1.5	22	9	4	8	CM20-1M	CM20-1RM
62	29	1.5	24	80	30.5	49.5	44	M24×1.5	25	11	4	8	CM24M	CM24RM
72	29	2	24	80	30.5	49.5	44	M24×1.5	25	11	4	8	CM24-1M	CM24-1RM
80	35	2	30	100	37	63	58	M30×1.5	32	15	4	8	CM30M	CM30RM
85	35	2	30	100	37	63	58	M30×1.5	32	15	4	8	CM30-1M	CM30-1RM
90	35	2	30	100	37	63	58	M30×1.5	32	15	4	8	CM30-2M	CM30-2RM

- [Notes] 1) Stud type track rollers with no lubrication hole on the stud threaded end.
 2) To calculate track roller rated service life, use these track roller load rating (C_t).
 Numerical values P_{\max} refer to maximum load track roller can accommodate. If track roller is fixed in housing as with regular type bearings, JIS basic static load rating values (C_{0r}) may apply.
 3) If track roller is fixed in housing, as with regular type bearings, rated service life can be calculated using JIS basic dynamic load rating values (C_r).

With seals

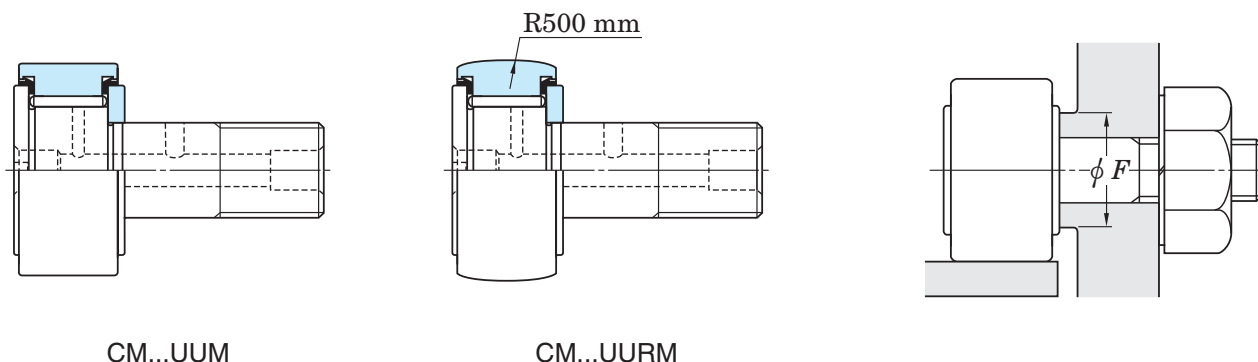

CM...UUM

CM...UURM

With seals		Clamping dia. F (mm)	Track roller load ratings ²⁾		JIS Basic load ratings ³⁾		Track capacity ⁴⁾ (kN)	Limiting speeds ⁵⁾ (min^{-1})		Tightening torque ⁶⁾ (N·m) max.	(Refer.) Mass (CM...M type) (kg)
Cylindrical outer ring	Crowned outer ring		C_t (kN)	P_{max} (kN)	C_r (kN)	C_{or} (kN)		Grease lub.	Oil lub.		
CM6UUM	CM6UURM	10.5	5.85	2.25	7.00	8.25	3.55	9 200	13 000	3.0	0.019
CM8UUM	CM8UURM	12.5	6.70	5.20	8.05	10.4	4.25	8 200	12 000	7.3	0.029
CM10UUM	CM10UURM	15	7.80	9.30	9.35	12.3	5.20	7 200	10 000	15	0.044
CM10-1UUM	CM10-1UURM	15	7.80	9.30	9.35	12.3	6.15	7 200	10 000	15	0.056
CM12UUM	CM12UURM	19	11.0	13.9	13.2	18.0	7.75	5 900	8 300	26	0.089
CM12-1UUM	CM12-1UURM	19	11.0	13.9	13.2	18.0	8.25	5 900	8 300	26	0.099
CM16UUM	CM16UURM	24	16.8	25.7	20.2	33.9	12.0	4 600	6 400	64	0.171
CM18UUM	CM18UURM	27	19.2	31.9	23.1	38.2	14.6	4 000	5 700	92	0.248
CM20UUM	CM20UURM	30.5	25.6	39.1	30.7	57.2	21.2	3 600	5 000	130	0.393
CM20-1UUM	CM20-1UURM	30.5	25.6	39.1	30.7	57.2	23.5	3 600	5 000	130	0.455
CM24UUM	CM24UURM	37.5	38.8	55.7	46.5	92.0	34.6	2 900	4 100	220	0.810
CM24-1UUM	CM24-1UURM	37.5	38.8	55.7	46.5	92.0	38.7	2 900	4 100	220	1.05
CM30UUM	CM30UURM	51	64.0	95.2	76.8	159	53.3	2 100	3 000	440	1.64
CM30-1UUM	CM30-1UURM	51	64.0	95.2	76.8	159	56.6	2 100	3 000	440	1.81
CM30-2UUM	CM30-2UURM	51	64.0	95.2	76.8	159	60.0	2 100	3 000	440	2.00

4) Track capacity is described earlier in this section (p. B 386).

The values listed in the table are the capacities of cylindrical track rollers.

5) Limiting speeds are applicable to without seals type.

6) Tightening torque apply when threaded portion is dry; if thread is wet with oil or other fluid, torque is half these values.

Stud type track rollers (cam followers) KM (caged type)

D 13 ~ 90 mm

Without seals

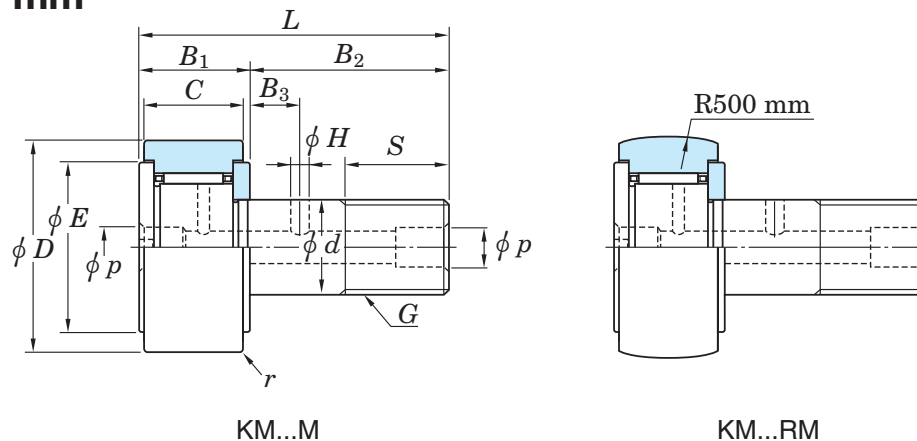

Outer ring			Boundary dimensions (mm)										Bearing No. Without seals	
D	C	$r_{\min.}$	Stud				Thread		Lubrication hole			Cylindrical outer ring	Crowned outer ring	
D	C	$r_{\min.}$	d	L	B_1	B_2	E	G	S	B_3	H	p		
13	9	0.3	5	23	10	13	10	M5×0.8	7.5	—	—	3 ¹⁾	KM5M	KM5RM
16	11	0.3	6	28	12	16	12	M6×1	9	—	—	4 ¹⁾	KM6M	KM6RM
19	11	0.3	8	32	12	20	15	M8×1.25	11	—	—	4 ¹⁾	KM8M	KM8RM
22	12	0.5	10	36	13	23	17	M10×1.25	13	—	—	4	KM10M	KM10RM
26	12	0.5	10	36	13	23	17	M10×1.25	13	—	—	4	KM10-1M	KM10-1RM
30	14	1	12	40	15	25	22	M12×1.5	14	6	3	6	KM12M	KM12RM
32	14	1	12	40	15	25	22	M12×1.5	14	6	3	6	KM12-1M	KM12-1RM
35	18	1	16	52	19.5	32.5	27	M16×1.5	18	8	3	6	KM16M	KM16RM
40	20	1.5	18	58	21.5	36.5	32	M18×1.5	20	8	3	6	KM18M	KM18RM
47	24	1.5	20	66	25.5	40.5	36	M20×1.5	22	9	4	8	KM20M	KM20RM
52	24	1.5	20	66	25.5	40.5	36	M20×1.5	22	9	4	8	KM20-1M	KM20-1RM
62	29	1.5	24	80	30.5	49.5	44	M24×1.5	25	11	4	8	KM24M	KM24RM
72	29	2	24	80	30.5	49.5	44	M24×1.5	25	11	4	8	KM24-1M	KM24-1RM
80	35	2	30	100	37	63	58	M30×1.5	32	15	4	8	KM30M	KM30RM
85	35	2	30	100	37	63	58	M30×1.5	32	15	4	8	KM30-1M	KM30-1RM
90	35	2	30	100	37	63	58	M30×1.5	32	15	4	8	KM30-2M	KM30-2RM

- [Notes]
- 1) Stud type track rollers with no lubrication hole on the stud threaded end.
 - 2) To calculate track roller rated service life, use these track roller load rating (C_t). Numerical values P_{\max} refer to maximum load track roller can accommodate. If track roller is fixed in housing as with regular type bearings, JIS basic static load rating values (C_{0r}) may apply.
 - 3) If track roller is fixed in housing, as with regular type bearings, rated service life can be calculated using JIS basic dynamic load rating values (C_r).

With seals

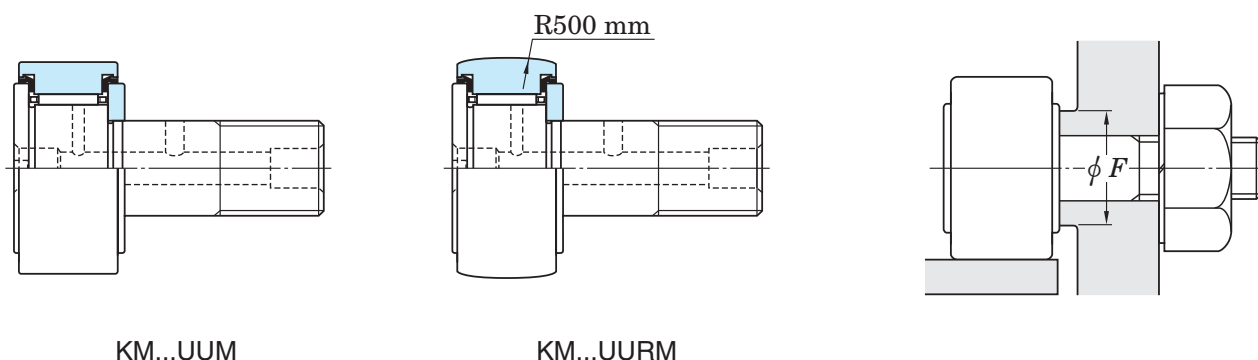

KM...UUM

KM...UURM

With seals		Clamping dia. F (mm)	Track roller load ratings ²⁾		JIS Basic load ratings ³⁾		Track capacity ⁴⁾ (kN)	Limiting speeds ⁵⁾ (min^{-1})		Tightening torque ⁶⁾ (N·m) max.	(Refer.) Mass (KM...M type) (kg)
Cylindrical outer ring	Crowned outer ring		C_t (kN)	P_{max} (kN)	C_r (kN)	C_{0r} (kN)		Grease lub.	Oil lub.		
KM5UUM	KM5UURM	9.0	2.20	1.60	2.65	2.45	2.35	16 000	22 000	1.8	0.010
KM6UUM	KM6UURM	10.5	3.40	2.25	4.10	4.05	3.55	15 000	20 000	3.0	0.018
KM8UUM	KM8UURM	12.5	3.80	4.10	4.55	4.90	4.25	13 000	18 000	7.3	0.028
KM10UUM	KM10UURM	15	5.20	6.05	6.25	7.25	5.20	11 000	16 000	15	0.043
KM10-1UUM	KM10-1UURM	15	5.20	6.05	6.25	7.25	6.15	11 000	16 000	15	0.055
KM12UUM	KM12UURM	19	6.80	8.00	8.20	9.60	7.75	9 500	13 000	26	0.087
KM12-1UUM	KM12-1UURM	19	6.80	8.00	8.20	9.60	8.25	9 500	13 000	26	0.096
KM16UUM	KM16UURM	24	10.8	15.8	13.0	18.9	12.0	7 400	10 000	64	0.166
KM18UUM	KM18UURM	27	13.3	19.6	15.9	23.5	14.6	6 500	8 900	92	0.245
KM20UUM	KM20UURM	30.5	17.7	29.5	21.3	35.4	21.2	5 700	7 900	130	0.387
KM20-1UUM	KM20-1UURM	30.5	17.7	29.5	21.3	35.4	23.5	5 700	7 900	130	0.453
KM24UUM	KM24UURM	37.5	26.3	46.1	31.6	55.3	34.6	4 600	6 400	220	0.801
KM24-1UUM	KM24-1UURM	37.5	26.3	46.1	31.6	55.3	38.7	4 600	6 400	220	1.04
KM30UUM	KM30UURM	51	46.5	86.9	55.8	104	53.3	3 400	4 700	440	1.62
KM30-1UUM	KM30-1UURM	51	46.5	86.9	55.8	104	56.6	3 400	4 700	440	1.79
KM30-2UUM	KM30-2UURM	51	46.5	86.9	55.8	104	60.0	3 400	4 700	440	1.98

4) Track capacity is described earlier in this section (p. B 386).

The values listed in the table are the capacities of cylindrical track rollers.

5) Limiting speeds are applicable to without seals type.

6) Tightening torque apply when threaded portion is dry; if thread is wet with oil or other fluid, torque is half these values.

Yoke type track rollers (roller followers) CYM (full complement type)

d 5 ~ 50 mm

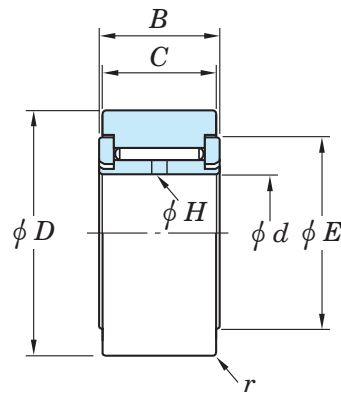

CYM...M

Without seals

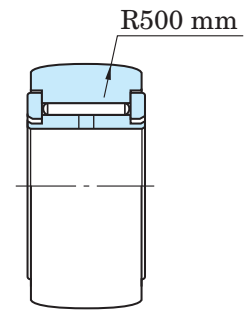

CYM...RM

Boundary dimensions (mm)							Bearing No.			
d	D	B	C	r min.	E	$H^{1)}$	Without seals		With seals	
							Cylindrical outer ring	Crowned outer ring	Cylindrical outer ring	Crowned outer ring
5	16	12	11	0.3	12	2	CYM5M	CYM5RM	CYM5UUM	CYM5UURM
6	19	12	11	0.3	15	2	CYM6M	CYM6RM	CYM6UUM	CYM6UURM
8	24	15	14	0.5	18	2	CYM8M	CYM8RM	CYM8UUM	CYM8UURM
10	30	15	14	1	22	2	CYM10M	CYM10RM	CYM10UUM	CYM10UURM
12	32	15	14	1	24	2	CYM12M	CYM12RM	CYM12UUM	CYM12UURM
15	35	19	18	1	27	2	CYM15M	CYM15RM	CYM15UUM	CYM15UURM
17	40	21	20	1.5	32	2.4	CYM17M	CYM17RM	CYM17UUM	CYM17UURM
20	47	25	24	1.5	36	2.4	CYM20M	CYM20RM	CYM20UUM	CYM20UURM
25	52	25	24	1.5	41	2.4	CYM25M	CYM25RM	CYM25UUM	CYM25UURM
30	62	29	28	1.5	51	3.2	CYM30M	CYM30RM	CYM30UUM	CYM30UURM
35	72	29	28	2	58	3.2	CYM35M	CYM35RM	CYM35UUM	CYM35UURM
40	80	32	30	2	63	3.2	CYM40M	CYM40RM	CYM40UUM	CYM40UURM
45	85	32	30	2	69	3.2	CYM45M	CYM45RM	CYM45UUM	CYM45UURM
50	90	32	30	2	75	3.2	CYM50M	CYM50RM	CYM50UUM	CYM50UURM

- [Notes]
- 1) Lubrication hole is provided on inner ring internal surface.
 - 2) To calculate track roller rated service life, use these track roller load rating values (C_t). Numerical values P_{max} refer to maximum load track roller can accommodate. If track roller is fixed in housing as with regular type bearings, JIS basic static load rating values (C_{0r}) may apply.
 - 3) If track roller is fixed in housing, as with regular type bearings, rated service life can be calculated using JIS basic dynamic load rating values (C_r).

With seals

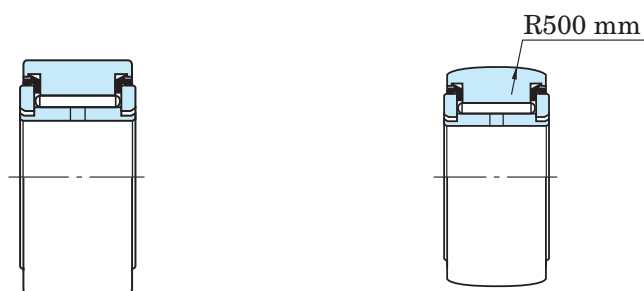

CYM...UUM

CYM...UURM

	Track roller load ratings ²⁾		JIS Basic load ratings ³⁾		Track capacity ⁴⁾ (kN)	Limiting speeds ⁵⁾ (min ⁻¹)		(Refer.) Mass (CYM...M type) (kg)
	C_t (kN)	P_{max} (kN)	C_r (kN)	C_{0r} (kN)		Grease lub.	Oil lub.	
	5.85	6.85	7.00	8.25	3.55	9 200	13 000	0.014
	6.70	8.70	8.05	10.4	4.25	8 200	12 000	0.021
	9.55	12.6	11.5	15.1	6.70	6 800	9 500	0.043
	11.1	15.1	13.3	18.1	7.75	5 900	8 300	0.062
	11.9	17.3	14.3	20.7	8.25	5 300	7 400	0.069
	16.8	28.2	20.2	33.9	12.0	4 600	6 400	0.105
	19.2	31.8	23.1	38.2	14.6	4 000	5 700	0.153
	25.6	47.7	30.7	57.3	21.2	3 600	5 000	0.255
	28.4	58.2	34.1	69.8	23.5	3 000	4 200	0.284
	41.5	88.8	49.8	107	33.3	2 400	3 400	0.476
	47.4	99.4	56.9	119	37.1	2 100	2 900	0.649
	58.3	122	70.0	147	44.7	1 900	2 600	0.845
	61.4	135	73.7	162	47.5	1 700	2 400	0.924
	64.2	148	77.0	177	50.3	1 600	2 200	0.984

- 4) Track capacity is described earlier in this section (p. B 386).
The values listed in the above table are the capacities of cylindrical track rollers.
The track capacities of crowned track rollers are 80 % of these values.
- 5) Limiting speeds are as measured with no seals.

Yoke type track rollers (roller followers) CXM (caged type)

d 5 ~ 50 mm

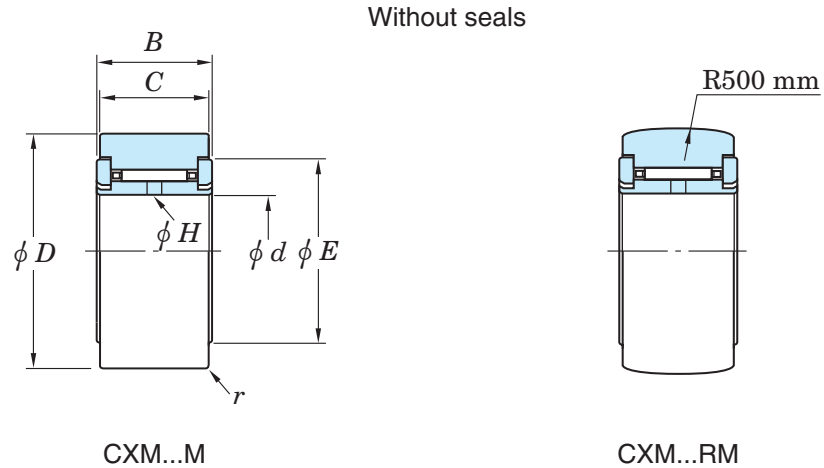

Boundary dimensions (mm)							Bearing No.			
d	D	B	C	r min.	E	H ¹⁾	Without seals		With seals	
							Cylindrical outer ring	Crowned outer ring	Cylindrical outer ring	Crowned outer ring
5	16	12	11	0.3	12	2	CXM5M	CXM5RM	CXM5UUM	CXM5UURM
6	19	12	11	0.3	15	2	CXM6M	CXM6RM	CXM6UUM	CXM6UURM
8	24	15	14	0.5	18	2	CXM8M	CXM8RM	CXM8UUM	CXM8UURM
10	30	15	14	1	22	2	CXM10M	CXM10RM	CXM10UUM	CXM10UURM
12	32	15	14	1	24	2	CXM12M	CXM12RM	CXM12UUM	CXM12UURM
15	35	19	18	1	27	2	CXM15M	CXM15RM	CXM15UUM	CXM15UURM
17	40	21	20	1.5	32	2.4	CXM17M	CXM17RM	CXM17UUM	CXM17UURM
20	47	25	24	1.5	36	2.4	CXM20M	CXM20RM	CXM20UUM	CXM20UURM
25	52	25	24	1.5	41	2.4	CXM25M	CXM25RM	CXM25UUM	CXM25UURM
30	62	29	28	1.5	51	3.2	CXM30M	CXM30RM	CXM30UUM	CXM30UURM
35	72	29	28	2	58	3.2	CXM35M	CXM35RM	CXM35UUM	CXM35UURM
40	80	32	30	2	63	3.2	CXM40M	CXM40RM	CXM40UUM	CXM40UURM
45	85	32	30	2	69	3.2	CXM45M	CXM45RM	CXM45UUM	CXM45UURM
50	90	32	30	2	75	3.2	CXM50M	CXM50RM	CXM50UUM	CXM50UURM

- [Notes]
- 1) Lubrication hole is provided on inner ring internal surface.
 - 2) To calculate track roller rated service life, use these track roller load rating values (C_t). Numerical values P_{max} refer to maximum load track roller can accommodate. If track roller is fixed in housing as with regular type bearings, JIS basic static load rating values (C_{0r}) may apply.
 - 3) If track roller is fixed in housing, as with regular type bearings, rated service life can be calculated using JIS basic dynamic load rating values (C_r).

With seals

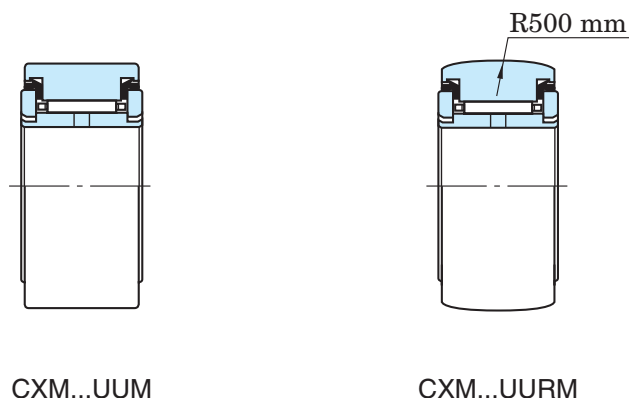

	Track roller load ratings ²⁾		JIS Basic load ratings ³⁾		Track capacity ⁴⁾ (kN)	Limiting speeds ⁵⁾ (min ⁻¹)		(Refer.) Mass (CXM...M type) (kg)
	C_t (kN)	P_{max} (kN)	C_r (kN)	C_{0r} (kN)		Grease lub.	Oil lub.	
	3.40	3.40	4.10	4.05	3.55	15 000	20 000	0.011
	3.80	4.10	4.55	4.90	4.25	13 000	18 000	0.018
	5.70	6.40	6.85	7.65	6.70	11 000	15 000	0.040
	6.80	8.00	8.20	9.60	7.75	9 500	13 000	0.060
	7.25	9.05	8.70	10.8	8.25	8 400	12 000	0.067
	10.8	15.8	13.0	18.9	12.0	7 400	10 000	0.102
	13.3	19.6	15.9	23.5	14.6	6 500	8 900	0.150
	17.7	29.5	21.3	35.4	21.2	5 700	7 900	0.252
	19.2	34.6	23.0	41.5	23.5	4 800	6 600	0.278
	28.4	53.9	34.0	64.7	33.3	3 900	5 300	0.465
	32.4	60.3	38.9	72.4	37.1	3 300	4 600	0.636
	41.4	78.1	49.7	93.7	44.7	3 000	4 100	0.825
	42.7	83.6	51.2	100	47.5	2 700	3 700	0.901
	45.5	93.9	54.6	113	50.3	2 500	3 400	0.960

- 4) Track capacity is described earlier in this section (p. B 386).
The values listed in the above table are the capacities of cylindrical track rollers.
The track capacities of crowned track rollers are 80 % of these values.
- 5) Limiting speeds are as measured with no seals.

Miniature one-way clutches

Miniature one-way clutches consist of a case carburizing steel drawn cup, metal or synthetic resin spring, synthetic resin cage and needle rollers.

They are used in clutch mechanisms of various machines. Use in office automation equipment such as copying and facsimile machines is especially common.

- Useful for making equipment smaller and lighter, due to a drawn cup made of thin sheet steel.
 - Locking protrusions are provided around the drawn cup, so that creeping can be prevented without having to hold the surface dimensional accuracy precisely.
 - Pre-lubricated with optimum grease, so that no lubrication is necessary under normal operating conditions.
 - Unit products with a synthetic resin housing are also available.
- They are compatible with components of various types, such as gears, timing pulleys, cams and rubber rollers. Consult with JTEKT for further information. Refer to JTEKT catalog "miniature one-way clutch".



1WC series



EWC series

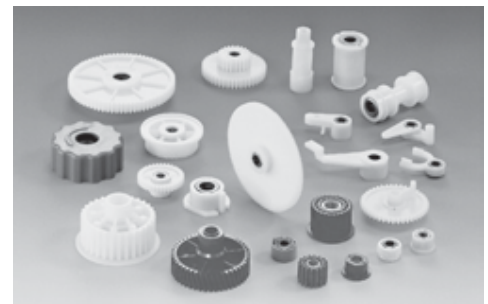

Various housings and unit products

Structure and principles

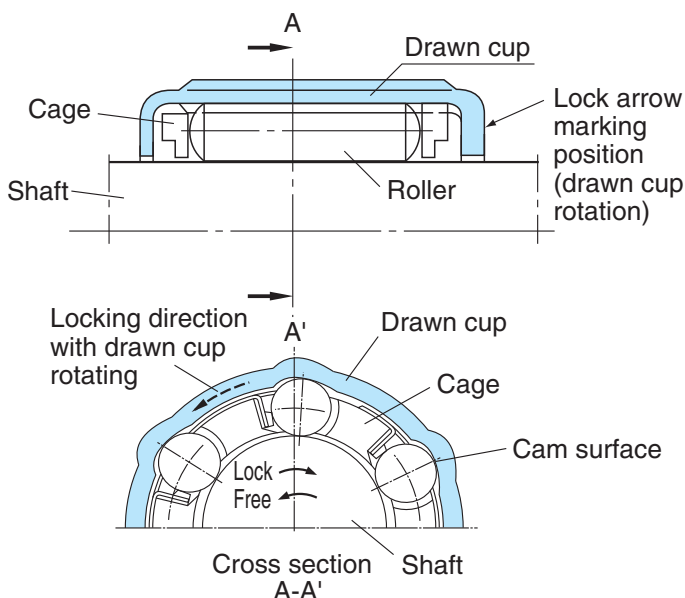

[When the clutch system works]

When the shaft rotates clockwise as in cross section A-A', rollers are locked while engaged with the drawn cup cam surfaces by the effect of springs (wedging of the shaft by the cam surfaces). The drawn cup is driven as a consequence.

[Clutch idle running]

When the shaft rotates counter-clockwise as in cross section A-A', rollers move away from the drawn cup cam surfaces and rotate freely.

■ Miniature one-way clutch types and characteristics

	1WC series (with metal springs)		EWC series (with synthetic resin springs)	
	Heavy load type		Heavy load type	Light load type
	1WC...		EWC...C	EWC...A
Torque capacity	Heavy load		Heavy load	Light load
Operating temperature range	- 10 to + 90°C		- 10 to + 70°C	
Locking life	Locking system can function more than one million. (Note : this estimation is valid as long as torque magnitude does not exceed the torque capacity shown in the specification table.)			
Insert molding	Possible		Impossible	
Delivery of clutch only	Possible			
Unit delivery	Possible			

■ Shaft tolerance

	Heavy load type (1WC... , EWC...C)	Light load type (EWC...A)
Shaft tolerance class	h 8	
Surface hardness	50 HRC or harder	30 HRC or harder
Roughness (Ra)	0.3 a or less	0.8 a or less
Roundness and cylindricity	0.005 mm or less	

[Remarks] In some operating conditions, shafts need not be as accurate as shown here.

For example :

- When clutch engaging accuracy is considered unimportant, or when a radial load or moment is not generated, the shaft diameter tolerance can be :

$\left\{ \begin{array}{l} \text{shaft diameter 6 mm or less,} \\ \text{and EWC0809 (C, A) : 0 to -0.040 mm} \\ \text{shaft diameter 8 mm or more : h 10} \end{array} \right.$

- When the loaded torque is smaller than the torque capacity, shaft surface hardness can be determined as follows :

* The diagram on the right shows approximate shaft surface hardness relative to torque ratio A.

$$\text{Torque ratio (A)} = \frac{\text{Loaded torque}}{\text{Heavy load type torque capacity}}$$

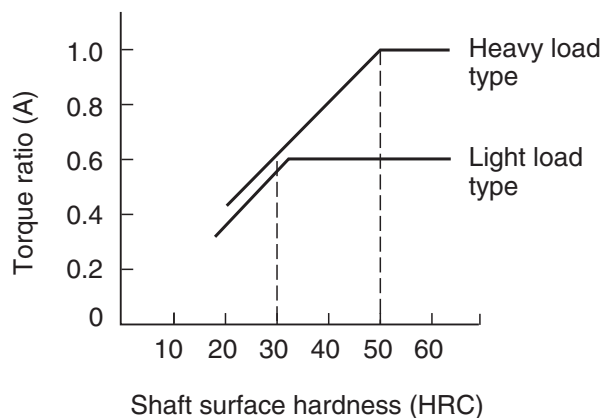

Miniature one-way clutches

d 4 ~ 12 mm

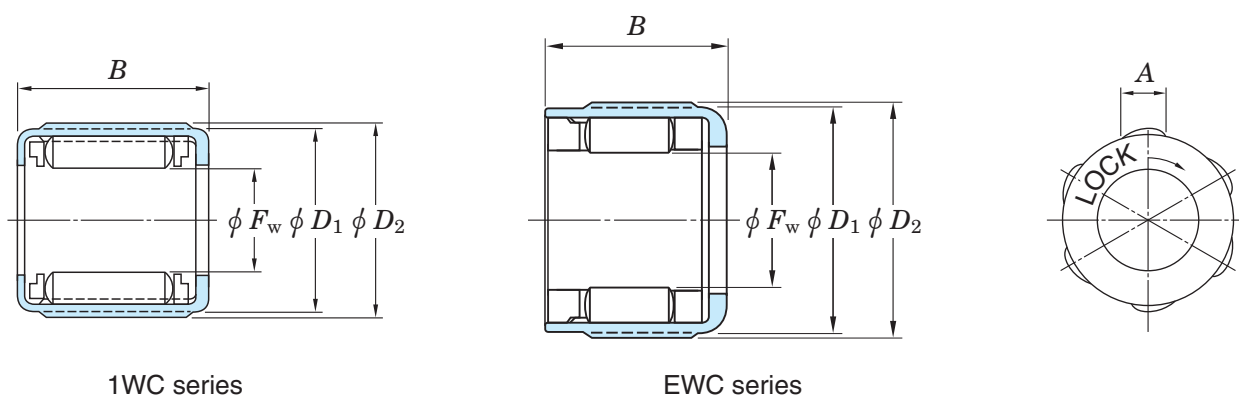

1WC series

EWC series

Shaft dia. (mm) d	Boundary dimensions (mm)					Torque capacity (N·m)	Designations	
	F_w	D_1	D_2	B	A		1WC series (With metal springs)	EWC series (With resin spring)
4	4	8	8.4	6	2.6	0.08	—	EWC0406A
	4	8	8.4	6	2.6	0.15	—	EWC0406C
6	6	10	10.4	8	2.8	0.25	—	EWC0608A
	6	10	10.4	8	2.8	0.44	—	EWC0608C
	6	10	10.4	8	2.8	0.44	1WC0608	—
	6	10	10.4	12	2.8	0.88	1WC0612	—
8	8	12	12.4	9	2.6	0.49	—	EWC0809A
	8	12	12.4	9	2.6	0.88	—	EWC0809C
	8	14.2	15	12	3.6	1.18	—	EWC0812A
	8	14.2	15	12	3.6	1.96	—	EWC0812C
	8	14.2	15	12	3.6	1.96	1WC0812	—
	8	14.2	15	14.5	3.6	2.65	1WC0815	—
10	10	16	17	10	5	1.18	—	EWC1010A
	10	16	17	10	5	1.96	—	EWC1010C
	10	16	17	12	5	1.37	—	EWC1012A
	10	16	17	12	5	2.35	—	EWC1012C
	10	16	17	12	5	2.35	1WC1012	—
12	12	18	19	16	5.1	6.28	1WC1216	—

[Notes] 1) Provided at equal intervals.
2) Recommended interference when polyacetal resin housing is used.

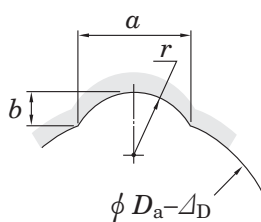
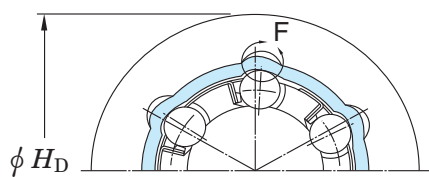

Details of section F

	No. of ¹⁾ outer ring protrusion	Recommended housing dimensions (mm)						(Refer.) Mass (g)	
		H_D	a	b	r	D_a	Δ_D ²⁾	1WC	EWC
	4	12	2.65	0.50	2	8	0.06	—	1.0
	4	12	2.65	0.50	2	8	0.06	—	1.0
	6	14	2.8	0.57	2	10	0.08	—	1.7
	6	14	2.8	0.57	2	10	0.08	—	1.7
	6	14	2.8	0.57	2	10	0.08	2.0	—
	6	14	2.8	0.57	2	10	0.08	3.0	—
	6	16	2.6	0.48	2	12	0.10	—	2.4
	6	16	2.6	0.48	2	12	0.10	—	2.4
	6	18.5	3.6	0.87	2.3	14.2	0.11	—	5.8
	6	18.5	3.6	0.87	2.3	14.2	0.11	—	5.8
	6	18.5	3.6	0.87	2.3	14.2	0.11	7.0	—
	6	18.5	3.6	0.87	2.3	14.2	0.11	8.0	—
	6	21	5.0	1.20	3.2	16	0.13	—	6.0
	6	21	5.0	1.20	3.2	16	0.13	—	6.0
	6	21	5.0	1.20	3.2	16	0.13	—	6.8
	6	21	5.0	1.20	3.2	16	0.13	—	6.8
	6	21	5.0	1.20	3.2	16	0.13	8.0	—
	8	23	5.1	1.20	3.3	18	0.14	12	—

KOYO



Ball bearing units

Ball bearing units consist of pre-lubricated sealed ball bearings and a housing which varies in shape.

They are capable of aligning themselves efficiently using the spherical fitting surface between the bearing and housing, effectively preventing overloads due to misalignment.

Koyo ball bearing units are highly accurate and feature excellent load resistance. They are completely sealed, and provided with a relubrication feature.

Ball bearing units without a relubrication feature are also available.

For details, refer to JTEKT separate catalog "Ball bearing units" (CAT. NO. B2007E).

Pillow block type

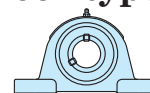

Bore diameter 12 – 140 mm

Flanged type

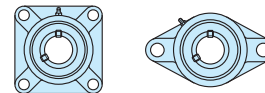

Bore diameter 12 – 140 mm

Flanged type with spigot joint



Bore diameter 12 – 140 mm

Take-up type

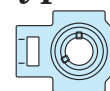

Bore diameter 12 – 140 mm

Cartridge type



Bore diameter 12 – 140 mm

Light duty units



Bore diameter 12 – 40 mm

"Compact" series (made from light alloy)



Bore diameter 10 – 30 mm

Stainless-series

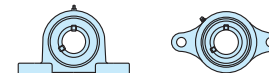

Bore diameter 12 – 50 mm

Pressed steel units



Bore diameter 12 – 35 mm







Ball bearings for units



Bore diameter 10 – 140 mm

Typical types of ball bearing unit

(1) Cast iron units

	<p>Pillow block type</p> <ul style="list-style-type: none"> ● UCP 2·X·3 ▲ UKP 2·X·3 ■ NAP 2
	<p>Square-flanged type</p> <ul style="list-style-type: none"> ● UCF 2·X·3 ▲ UKF 2·X·3 ■ NANF 2
	<p>Square-flanged type with spigot joint</p> <ul style="list-style-type: none"> ● UCFS 3 ▲ UKFS 3
	<p>Rhombic-flanged type</p> <ul style="list-style-type: none"> ● UCFL 2·X·3 ▲ UKFL 2·X·3 ■ NANFL 2
	<p>Round-flanged type with spigot joint</p> <ul style="list-style-type: none"> ● UCFC 2·X ▲ UKFC 2·X ■ NAFC 2
	<p>Take-up type</p> <ul style="list-style-type: none"> ● UCT 2·X·3 ▲ UKT 2·X·3 ■ NAT 2
	<p>Cartridge type</p> <ul style="list-style-type: none"> ● UCC 2·X·3 ▲ UKC 2·X·3 ■ NAC 2

Special pillow block types

Thick section pillow block type



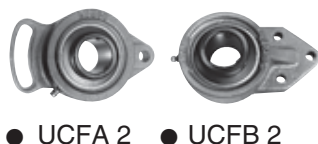

Flanged types





Hanger type







(2) Light duty units (cast iron)

	
● BLP 2	● BLF 2



(3) "Compact" series units (special light alloy)

	
● UP 0	● UFL 0



(4) Stainless-series units (stainless steel)

	
● UCSP 2...H1S6	● UCSFL 2...H1S6
	
● USP 0...S6	● USFL 0...S6



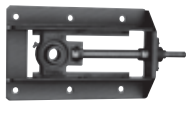

(5) Pressed steel units

		
● SBPP2	● SBPFL2	● SBPF2

(6) Take-up units with frame

	
<ul style="list-style-type: none"> ● UCTH 2 (● SBNPTH 2) (● SBPTH 2) 	<ul style="list-style-type: none"> ● UCTL 2 ● UCTU 2 ● UCTU 3

(7) Ball bearings for units

	<p>Cylindrical bore type (with set screws)</p> <ul style="list-style-type: none"> ● UC 2·X·3 ● SB 2 ● SU 0 		<p>Cylindrical bore type (with set screws)</p> <ul style="list-style-type: none"> ● RB 2 <p>(Sealed deep groove ball bearings having an extended inner ring.)</p>
	<p>Tapered bore type (with adapter)</p> <ul style="list-style-type: none"> ▲ UK 2·X·3 		<p>Cylindrical bore type (with set screws)</p> <ul style="list-style-type: none"> ● ER 2 <p>(Sealed deep groove ball bearings having an extended inner ring and an outer ring provided with a locating snap ring, lubrication groove and lubrication holes.)</p>
	<p>Cylindrical bore type (with eccentric locking collar)</p> <ul style="list-style-type: none"> ■ NA 2 		

[Note] This catalog includes the specifications of major units and bearings which are boxed in the table. For further details, refer to a separate catalog.

Marks ●, ▲ and ■ indicate, respectively, that the unit or bearing is fixed with a set screw, adapter, or eccentric locking collar.

Tolerances	<ul style="list-style-type: none"> · Ball bearings as specified in JIS B 1558 (Tables 1 and 2). (refer to Table 7-11, class 0 on p. A 70 for the tapered bore tolerance.) · Housings.....as specified in JIS B 1559. (the internal spherical diameter tolerance is given in Table 3. For other tolerances, refer to a separate catalog.)
Bearing radial internal clearance	<p>As specified in JIS B 1520 (Table 10-2 on p. A 96). JTEKT provides cylindrical bore bearings with standard radial internal clearance. Tapered bore bearings are provided with a C 3 radial internal clearance in consideration of possible inner ring expansion caused by tightening of an adapter.</p>
Recommended fits of inner ring and shaft (indicated by the tolerance class)	<ul style="list-style-type: none"> · Cylindrical bore bearings.....h 6, h 7, h 8, j 6 (k 6, k 7 and m 6 when heavy or impact load is to be supported.) · Tapered bore bearings.....h 8, h 9 · High-speed blower bearings (S5)...h 5, j 5
Rotational speed limits	See Table 4.
Allowable aligning angle	<ul style="list-style-type: none"> · 0.052 rad (3°) · For units with a cover, it is best if the misalignment is 0.017 rad (1°) or less to prevent the rubber seal lip on the cover and the shaft contact from distorting the seal lip.

Table 1 Cylindrical bore bearings for units : inner ring tolerance Unit : μm

Nominal bore diameter d (mm)		UC, SA, NA, SU, SB, RB and ER types			Bearings for blower (S5)			Single inner (outer) ring width deviation $\Delta_{Bs} (\Delta_{Cs})$		Radial runout of assembled bearing inner ring K_{ia}
		Single plane mean bore diameter deviation Δ_{dmp}		Single plane bore diameter variation V_{dsp}	Single plane mean bore diameter deviation Δ_{dmp}		Single plane bore diameter variation V_{dsp}			
over	up to	upper	lower	max.	upper	lower	max.	upper	lower	max.
10 more	18	+ 15	0	10	+ 13	0	6	0	- 120	15
18	31.75	+ 18	0	12	+ 13	0	6	0	- 120	18
31.75	50.8	+ 21	0	14	+ 13	0	10	0	- 120	20
50.8	80	+ 24	0	16	+ 15	0	10	0	- 150	25
80	120	+ 28	0	19	+ 18	0	14	0	- 200	30
120	180	+ 33	0	22	+ 23	0	14	0	- 250	35

Table 2 Ball bearings for units : outer ring tolerance Unit : μm

Nominal outside diameter D (mm)		Mean outside diameter deviation Δ_{Dm}		Radial runout of assembled bearing outer ring K_{ea}
over	up to	upper	lower	
30	50	0	- 11	20
50	80	0	- 13	25
80	120	0	- 15	35
120	150	0	- 18	40
150	180	0	- 25	45
180	250	0	- 30	50
250	315	0	- 35	60

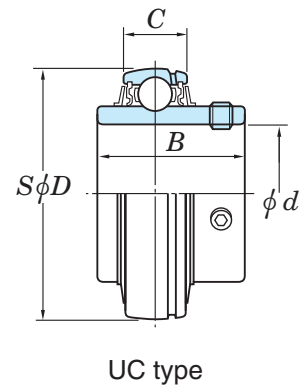

[Note] The lower value of mean outside diameter deviation does not apply to the sides of outer rings up to the extent of a quarter of the outer ring width from the side faces.

Table 3 Housing bore internal spherical diameter tolerance Unit : μm

Nominal spherical bore diameter D_a (mm)		Tolerance class H		Tolerance class J		Tolerance class K	
		Deviation of spherical bearing seat dia. Δ_{Dam}		Deviation of spherical bearing seat dia. Δ_{Dam}		Deviation of spherical bearing seat dia. Δ_{Dam}	
over	up to	upper	lower	upper	lower	upper	lower
30	50	+ 25	0	+ 14	- 11	+ 7	- 18
50	80	+ 30	0	+ 18	- 12	+ 9	- 21
80	120	+ 35	0	+ 22	- 13	+ 10	- 25
120	180	+ 40	0	+ 26	- 14	+ 12	- 28
180	250	+ 46	0	+ 30	- 16	+ 13	- 33
250	315	+ 52	0	+ 36	- 16	+ 16	- 36

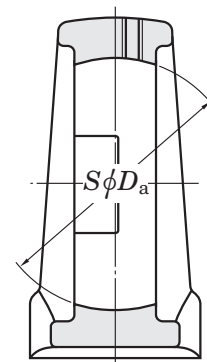

[Remark] JTEKT generally applies class J to housing designs.
Class H and class K can also be applied depending on the application.

Table 4 Limiting speed of ball bearing units

 Unit : min⁻¹

Bore diameter No.	Standard Cold resistant type (D2K2)			Triple-lip sealed (L3)			For high speed rotation (K3 and S5)			Heat resistant type (D1K2)
	Diameter series			Diameter series			Diameter series			Diameter series
	2	X	3	2	X	3	2	X	3	2, X, 3
01	5 800			2 300			8 700			3 800
02	5 800			2 300			8 700			3 800
03	5 800			2 300			8 700			3 800
04	5 800	–	–	2 300	–		8 700	–	–	3 800
05	5 100	4 300	4 600	2 100	960		7 700	6 400	6 700	3 000
06	4 300	3 700	3 900	960	830	–	6 400	5 500	5 800	2 500
07	3 700	3 300	3 400	830	750	770	5 500	5 000	5 100	2 100
08	3 300	3 100	3 100	750	690	690	5 000	4 600	4 600	1 900
09	3 100	2 800	2 700	690	640	620	4 600	4 300	4 100	1 700
10	2 800	2 500	2 400	640	570	550	4 300	3 800	3 700	1 500
11	2 500	2 300	2 300	570	520	510	3 800	3 500	3 400	1 400
12	2 300	2 200	2 100	520	490	470	3 500	3 200	3 100	1 300
13	2 200	2 100	1 900	490	460	440	3 200	3 100	2 900	1 200
14	2 100	2 000	1 800	460	440	410	3 100	2 900	2 700	1 100
15	2 000	1 800	1 700	440	410	380	2 900	2 700	2 600	1 000
16	1 800	1 700	1 600	410	380	360	2 700	2 600	2 400	940
17	1 700	1 600	1 500	380	360	340	2 600	2 400	2 300	880
18	1 600	1 500	1 400	360	340	320	2 400	2 300	2 100	830
19		–	1 400		–	310		–	2 000	790
20		1 300	1 300		300	280		2 000	1 900	750
21		–	1 200		–	270		–	1 800	710
22			1 100			250			1 700	680
24			1 100			240			1 600	630
26			1 000			220			1 500	580
28			910			200			1 400	540

- [Remarks] 1. The rotational speed limits of units with a cover are 80 % of the values given in the table above.
 2. When bearings are fit loosely, rotational speed limits should be compensated for by the fitting coefficient given below.

Bearing type	Fitting coefficient					
	Shaft tolerance class					
	h5, j5	j6	h6	h7	h8	h9
Standard	–	1.0	1.0	0.8	0.5	0.2
Triple-lip sealed (L3)	–	–	–	1.0	1.0	0.9
For high speed rotation (K3)	–	1.0	0.8	0.6	–	–
For blower (S5)	1.0	–	0.8	0.6	–	–
Heat-resistant type B (D1K2)	–	–	–	1.0	1.0	0.7

[Recommended shaft design]

**Table 5 Shaft fits for cylindrical bore bearing
-Clearance fit or transition fit-**

Unit : μm

Shaft diameter (mm)		Tolerance of shaft							
		j6		h6		h7		h8	
over	up to	upper	lower	upper	lower	upper	lower	upper	lower
10	18	+ 8	- 3	0	- 11	0	- 18	0	- 27
18	30	+ 9	- 4	0	- 13	0	- 21	0	- 33
30	50	+ 11	- 5	0	- 16	0	- 25	0	- 39
50	80	+ 12	- 7	0	- 19	0	- 30	0	- 46
80	120	+ 13	- 9	0	- 22	0	- 35	0	- 54
120	180	+ 14	- 11	0	- 25	0	- 40	0	- 63
Operating speed $dn^{1)}$		120 000 over		100 000 over 120 000 up to		60 000 over 100 000 up to		60 000 up to	

[Note] 1) $dn = d$ (Bearing bore, mm) $\times n$ (Rotating speed, min^{-1})

**Table 6 Shaft fits for cylindrical bore bearing
-Transition fit or Interference fit-**

Unit : μm

Shaft diameter (mm)		Tolerance of shaft					
		k6		k7		m6	
over	up to	upper	lower	upper	lower	upper	lower
10	18	+ 12	+ 1	+ 19	+ 1	+ 18	+ 7
18	30	+ 15	+ 2	+ 23	+ 2	+ 21	+ 8
30	50	+ 18	+ 2	+ 27	+ 2	+ 25	+ 9
50	80	+ 21	+ 2	+ 32	+ 2	+ 30	+ 11
80	120	+ 25	+ 3	+ 38	+ 3	+ 35	+ 13
120	180	+ 28	+ 3	+ 43	+ 3	+ 40	+ 15

Table 8 Shaft fits for tapered bore bearing

Unit : μm

Shaft diameter (mm)		Tolerance of shaft			
		h8		h9	
over	up to	upper	lower	upper	lower
10	18	0	- 27	0	- 43
18	30	0	- 33	0	- 52
30	50	0	- 39	0	- 62
50	80	0	- 46	0	- 74
80	120	0	- 54	0	- 87
120	180	0	- 63	0	- 100

Table 7 Shaft fits for bearings for blower

Unit : μm

Shaft diameter (mm)		Tolerance of shaft			
		h5		j5	
over	up to	upper	lower	upper	lower
10	18	0	- 8	+ 5	- 3
18	30	0	- 9	+ 5	- 4
30	50	0	- 11	+ 6	- 5
50	80	0	- 13	+ 6	- 7
80	120	0	- 15	+ 6	- 9
120	180	0	- 18	+ 7	- 11

**Table 9 Recommended tolerances of
shaft used for ball bearing units**

Unit : μm

Shaft diameter (mm)		Deviation from circular and cylindrical forms (max.)
over	up to	
	10	6
10	18	8
18	30	9
30	50	11
50	80	13
80	120	15
120	180	18

Table 10 Shaft shoulder dia. and fillet radius

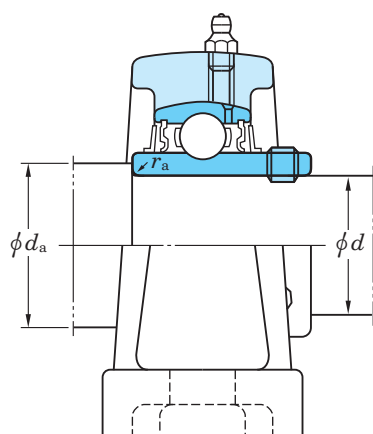

Unit : μm

Bore No.	Nominal bore dia.	UC200, UCX00		UC300	
		d_a	r_a (max.)	d_a	r_a (max.)
01	12	17	0.6		
02	15	20	0.6		
03	17	22	0.6		
04	20	30	1	—	—
05	25	35	1	35	1
06	30	40	1	40	1
07	35	45	1	45	1.5
08	40	50	1	50	1.5
09	45	55	1	55	1.5
10	50	60	1	60	2
11	55	65	1.5	65	2
12	60	70	1.5	75	2
13	65	75	1.5	80	2
14	70	80	1.5	85	2
15	75	85	1.5	90	2
16	80	90	2	95	2
17	85	95	2	100	2.5
18	90	100	2	105	2.5
19	95	—	—	110	2.5
20	100	115	2	115	2.5
21	105	—	—	120	2.5
22	110			125	2.5
24	120			135	2.5
26	130			150	3
28	140			160	3

Ball bearing units pillow block type UCP (with set screws)

d 12 ~ (55) mm

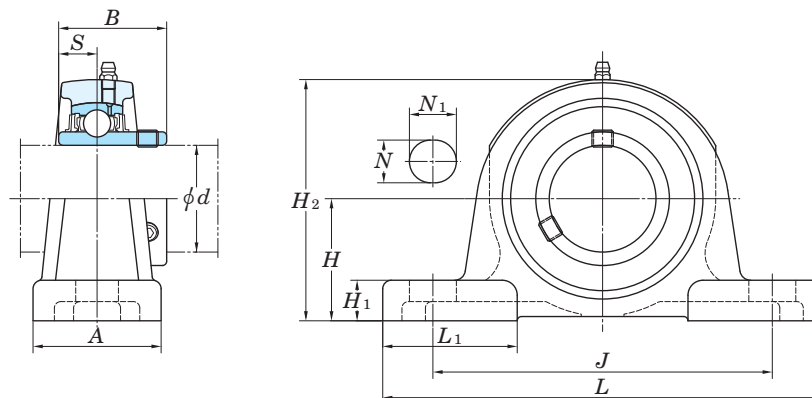

Shaft dia. (mm) d	Dimensions (mm)											Bolt size	Unit No.	Housing No.
	H	L	A	J	N	N_1	H_1	H_2	L_1	B	S			
12	30.2	127	38	95	13	18	12	60	38	31	12.7	M10	UCP201	P203
15	30.2	127	38	95	13	18	12	60	38	31	12.7	M10	UCP202	P203
17	30.2	127	38	95	13	18	12	60	38	31	12.7	M10	UCP203	P203
20	33.3	127	38	95	13	18	13	64	38	31	12.7	M10	UCP204	P204
25	36.5	140	38	105	13	18	13	71	43	34.1	14.3	M10	UCP205	P205
	44.4	159	51	119	17	25	16	86	47	38.1	15.9	M14	UCPX05	PX05
	45	175	45	132	17	20	16	85	55	38	15	M14	UCP305	P305
30	42.9	165	48	121	17	21	15	84	53	38.1	15.9	M14	UCP206	P206
	47.6	175	57	127	17	25	17	93	55	42.9	17.5	M14	UCPX06	PX06
	50	180	50	140	17	20	17	95	53	43	17	M14	UCP306	P306
35	47.6	167	48	127	17	21	16	93	51	42.9	17.5	M14	UCP207	P207
	54	203	57	144	17	30	19	105	64	49.2	19	M14	UCPX07	PX07
	56	210	56	160	17	25	19	107	65	48	19	M14	UCP307	P307
40	49.2	184	54	137	17	21	17	98	57	49.2	19	M14	UCP208	P208
	58.7	222	67	156	20	32	21	114	71	49.2	19	M16	UCPX08	PX08
	60	220	60	170	17	27	19	118	65	52	19	M14	UCP308	P308
45	54	190	54	146	17	21	17	106	60	49.2	19	M14	UCP209	P209
	58.7	222	67	156	20	33	21	116	71	51.6	19	M16	UCPX09	PX09
	67	245	67	190	20	30	21	132	75	57	22	M16	UCP309	P309
50	57.2	206	60	159	20	22	19	113	63	51.6	19	M16	UCP210	P210
	63.5	241	73	171	20	36	22	126	76	55.6	22.2	M16	UCPX10	PX10
	75	275	75	212	20	35	24	148	88	61	22	M16	UCP310	P310
55	63.5	219	60	171	20	22	19	125	70	55.6	22.2	M16	UCP211	P211

[Remarks] 1) Applicable sizes of grease nipples are shown below.
 A-1/4-28UNF..... 201~210, X05~X09, 305~308
 A-PT 1/8 211~218, X10~X20, 309~328

Tolerance for housing

Pressed steel covers

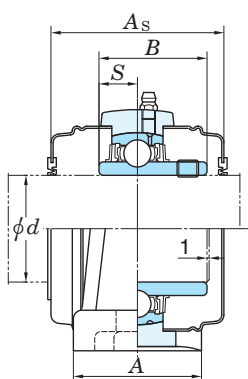

Cast iron covers

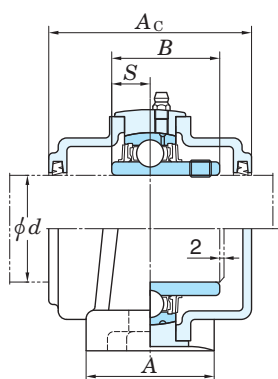

unit : mm

housing No.			ΔH_s
P203~ P210	PX05~ PX10	P305~ P310	± 0.15
P211~ P218	PX11~ PX18	P311~ P318	± 0.2
	PX20	P319~ P328	± 0.3

ΔH_s : deviation of distance from mounting base to centre of spherical bearing seating.

P204JE3, P205JE3 (with cast iron covers) are shown below.



No.	Applicable bearing			Unit No. with covers				Cover dimensions (mm)		(Refer.) Unit mass (kg)	
	Basic load ratings (kN)		Factor f_0	Pressed steel covers		Cast iron covers		A_s	A_c	Pressed steel covers	Cast iron covers
	C_r	C_{0r}		Open ends	Closed end	Open ends	Closed end				
UC201	12.8	6.65	13.2	UCP201C	UCP201CD	—	—	44	—	0.63	—
UC202	12.8	6.65	13.2	UCP202C	UCP202CD	—	—	44	—	0.61	—
UC203	12.8	6.65	13.2	UCP203C	UCP203CD	—	—	44	—	0.60	—
UC204	12.8	6.65	13.2	UCP204C	UCP204CD	UCP204FC	UCP204FCD	44	62	0.66	0.96
UC205	14.0	7.85	13.9	UCP205C	UCP205CD	UCP205FC	UCP205FCD	48	66	0.80	1.2
UCX05	19.5	11.3	13.9	UCPX05C	UCPX05CD	—	—	52	—	1.5	—
UC305	21.2	10.9	12.6	—	—	UCP305C	UCP305CD	—	76	1.7	2.3
UC206	19.5	11.3	13.9	UCP206C	UCP206CD	UCP206FC	UCP206FCD	52	70	1.3	1.8
UCX06	25.7	15.4	13.9	UCPX06C	UCPX06CD	—	—	59	—	2.1	—
UC306	26.7	15.0	13.3	—	—	UCP306C	UCP306CD	—	82	2.2	2.8
UC207	25.7	15.4	13.9	UCP207C	UCP207CD	UCP207FC	UCP207FCD	59	78	1.6	2.3
UCX07	29.1	17.8	14.0	UCPX07C	UCPX07CD	—	—	68	—	2.7	—
UC307	33.4	19.3	13.2	—	—	UCP307C	UCP307CD	—	88	3.0	3.8
UC208	29.1	17.8	14.0	UCP208C	UCP208CD	UCP208FC	UCP208FCD	68	86	2.0	2.8
UCX08	32.7	20.3	14.0	UCPX08C	UCPX08CD	—	—	68	—	3.5	—
UC308	40.7	24.0	13.2	—	—	UCP308C	UCP308CD	—	96	3.8	4.8
UC209	32.7	20.3	14.0	UCP209C	UCP209CD	UCP209FC	UCP209FCD	68	88	2.2	3.0
UCX09	35.1	23.3	14.4	UCPX09C	UCPX09CD	—	—	73	—	3.7	—
UC309	48.9	29.5	13.3	—	—	UCP309C	UCP309CD	—	102	4.9	6.2
UC210	35.1	23.3	14.4	UCP210C	UCP210CD	UCP210FC	UCP210FCD	73	97	2.9	3.9
UCX10	43.4	29.4	14.4	UCPX10C	UCPX10CD	—	—	75	—	4.6	—
UC310	62.0	38.3	13.2	—	—	UCP310C	UCP310CD	—	110	6.6	8.2
UC211	43.4	29.4	14.4	UCP211C	UCP211CD	UCP211FC	UCP211FCD	75	99	3.6	4.8

2) For bearings with double- or triple-lip seals, unit and bearing number are suffixed by L2 or L3.

3) For more detailed information, refer to ball bearing for unit specification tables.

Ball bearing units pillow block type UCP (with set screws)

d (55) ~ 95 mm

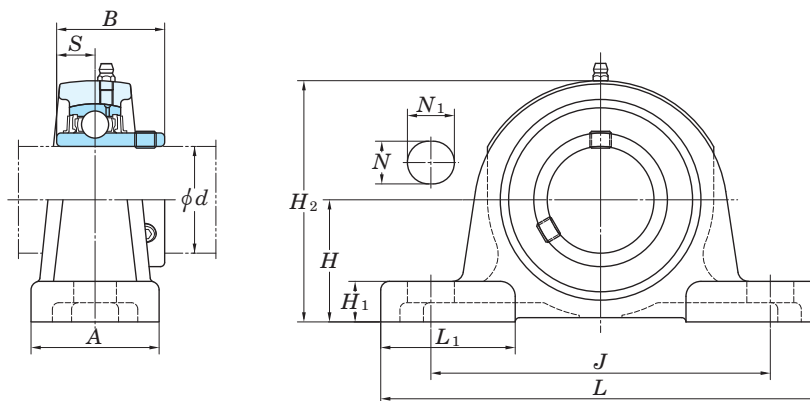

Shaft dia. (mm) d	Dimensions (mm)											Bolt size	Unit No.	Housing No.
	H	L	A	J	N	N_1	H_1	H_2	L_1	B	S			
55	69.8	260	79	184	25	36	28	139	83	65.1	25.4	M20	UCPX11	PX11
	80	310	80	236	20	38	27	158	90	66	25	M16	UCP311	P311
60	69.8	241	70	184	20	25	22	138	76	65.1	25.4	M16	UCP212	P212
	76.2	286	83	203	25	40	28	152	88	65.1	25.4	M20	UCPX12	PX12
	85	330	85	250	25	38	29	167	103	71	26	M20	UCP312	P312
65	76.2	265	70	203	25	30	25	150	78	65.1	25.4	M20	UCP213	P213
	76.2	286	83	203	25	40	28	155	88	74.6	30.2	M20	UCPX13	PX13
	90	340	90	260	25	38	32	176	110	75	30	M20	UCP313	P313
70	79.4	266	72	210	25	30	28	156	78	74.6	30.2	M20	UCP214	P214
	88.9	330	89	229	27	50	32	171	98	77.8	33.3	M22	UCPX14	PX14
	95	360	90	280	27	40	35	186	110	78	33	M22	UCP314	P314
75	82.6	275	74	217	25	30	28	162	80	77.8	33.3	M20	UCP215	P215
	88.9	330	89	229	27	50	32	175	99	82.6	33.3	M22	UCPX15	PX15
	100	380	100	290	27	40	35	198	107	82	32	M22	UCP315	P315
80	88.9	292	78	232	25	35	32	174	86	82.6	33.3	M20	UCP216	P216
	101.6	381	102	283	27	58	34	195	116	85.7	34.1	M22	UCPX16	PX16
	106	400	110	300	27	40	35	209	120	86	34	M22	UCP316	P316
85	95.2	310	83	247	25	40	32	185	90	85.7	34.1	M20	UCP217	P217
	101.6	381	102	283	27	60	34	200	116	96	39.7	M22	UCPX17	PX17
	112	420	110	320	33	45	40	220	120	96	40	M27	UCP317	P317
90	101.6	327	88	262	27	45	34	198	104	96	39.7	M22	UCP218	P218
	101.6	381	111	283	27	60	38	204	116	104	42.9	M22	UCPX18	PX18
	118	430	110	330	33	45	40	234	120	96	40	M27	UCP318	P318
95	125	470	120	360	36	50	46	248	125	103	41	M30	UCP319	P319

[Remarks] 1) Applicable sizes of grease nipples are shown below.
 A-1/4-28UNF 201~210, X05~X09, 305~308
 A-PT 1/8 211~218, X10~X20, 309~328

Tolerance for housing

Pressed steel covers

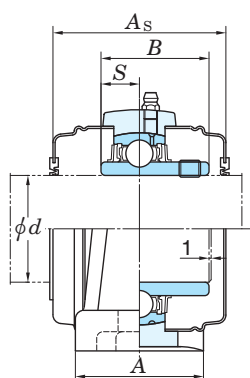

Cast iron covers

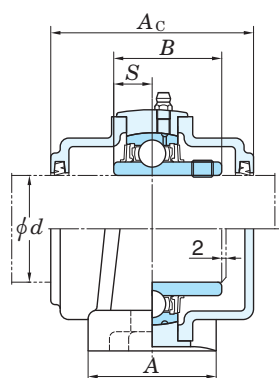

housing No.			ΔH_s
P203~ P210	PX05~ PX10	P305~ P310	± 0.15
P211~ P218	PX11~ PX18	P311~ P318	± 0.2
	PX20	P319~ P328	± 0.3

ΔH_s : deviation of distance from mounting base to centre of spherical bearing seating.

No.	Applicable bearing			Unit No. with covers				Cover dimensions (mm)		(Refer.) Unit mass (kg)	
	Basic load ratings (kN)		Factor f_0	Pressed steel covers		Cast iron covers		A_s	A_c	Pressed steel covers	Cast iron covers
	C_r	C_{0r}		Open ends	Closed end	Open ends	Closed end				
UCX11 UC311	52.4 71.6	36.2 45.0	14.4 13.2	UCPX11C —	UCPX11CD —	— UCP311C	— UCP311CD	88 —	— 114	6.5 7.9	— 9.7
UC212 UCX12 UC312	52.4 57.2 81.9	36.2 40.1 52.2	14.4 14.4 13.2	UCP212C UCPX12C —	UCP212CD UCPX12CD —	UCP212FC — UCP312C	UCP212FCD — UCP312CD	88 88 —	114 — 124	4.9 7.7 9.5	6.4 — 11.8
UC213 UCX13 UC313	57.2 62.2 92.7	40.1 44.1 59.9	14.4 14.5 13.2	UCP213C UCPX13C —	UCP213CD UCPX13CD —	UCP213FC — UCP313C	UCP213FCD — UCP313CD	88 98 —	114 — 122	5.9 8.1 10.7	7.6 — 12.8
UC214 UCX14 UC314	62.2 67.4 104	44.1 48.3 68.2	14.5 14.5 13.2	UCP214C UCPX14C —	UCP214CD UCPX14CD —	UCP214FC — UCP314C	UCP214FCD — UCP314CD	98 98 —	124 — 124	6.8 10.2 12.4	8.7 — 14.7
UC215 UCX15 UC315	67.4 72.7 113	48.3 53.0 77.2	14.5 14.6 13.2	UCP215C UCPX15C —	UCP215CD UCPX15CD —	UCP215FC — UCP315C	UCP215FCD — UCP315CD	98 108 —	124 — 134	7.4 10.8 14.8	9.3 — 17.3
UC216 UCX16 UC316	72.7 84.0 123	53.0 61.9 86.7	14.6 14.5 13.3	UCP216C UCPX16C —	UCP216CD UCPX16CD —	UCP216FC — UCP316C	UCP216FCD — UCP316CD	108 112 —	138 — 138	9.0 15.3 18.5	11.4 — 21.4
UC217 UCX17 UC317	84.0 96.1 133	61.9 71.5 96.8	14.5 14.5 13.3	UCP217C UCPX17C —	UCP217CD UCPX17CD —	UCP217FC — UCP317C	UCP217FCD — UCP317CD	112 122 —	142 — 146	10.8 16.1 20.3	13.5 — 23.6
UC218 UCX18 UC318	96.1 109 143	71.5 81.9 107	14.5 14.4 13.3	UCP218C — —	UCP218CD — —	UCP218FC UCPX18C UCP318C	UCP218FCD UCPX18CD UCP318CD	122 — —	152 158 150	13.9 19.1 22.8	17.0 22.5 26.6
UC319	153	119	13.3	—	—	UCP319C	UCP319CD	—	162	29.0	33.3

2) For bearings with double- or triple-lip seals, unit and bearing number are suffixed by L2 or L3.

3) For more detailed information, refer to ball bearing for unit specification tables.

Ball bearing units pillow block type UCP (with set screws)

d 100 ~ 140 mm

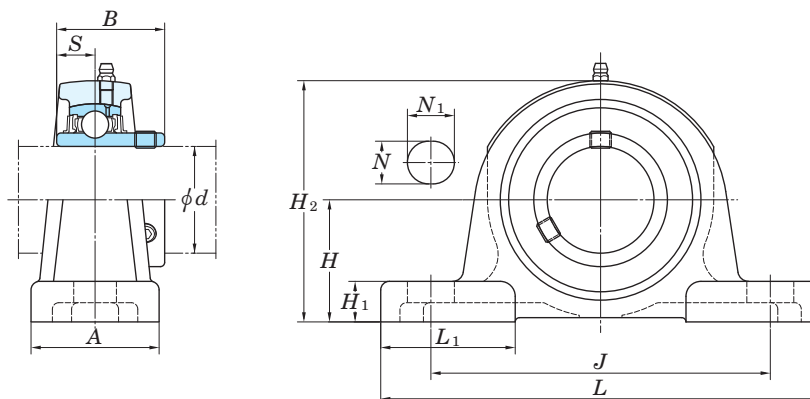

Shaft dia. (mm) d	Dimensions (mm)											Bolt size	Unit No.	Housing No.
	H	L	A	J	N	N_1	H_1	H_2	L_1	B	S			
100	127	432	121	337	33	65	45	245	126	117.5	49.2	M27	UCPX20	PX20
	140	490	120	380	36	50	46	273	140	108	42	M30	UCP320	P320
105	140	490	120	380	36	50	46	278	140	112	44	M30	UCP321	P321
110	150	520	140	400	40	55	50	296	150	117	46	M33	UCP322	P322
120	160	570	140	450	40	55	50	316	160	126	51	M33	UCP324	P324
130	180	600	140	480	40	55	50	355	195	135	54	M33	UCP326	P326
140	200	620	140	500	40	55	60	393	185	145	59	M33	UCP328	P328

[Remarks] 1) Applicable sizes of grease nipples are shown below.
 A-1/4-28UNF 201~210, X05~X09, 305~308
 A-PT 1/8 211~218, X10~X20, 309~328

Tolerance for housing

unit : mm

housing No.			ΔH_s
P203~ P210	PX05~ PX10	P305~ P310	± 0.15
P211~ P218	PX11~ PX18	P311~ P318	± 0.2
	PX20	P319~ P328	± 0.3

ΔH_s : deviation of distance from mounting base to centre of spherical bearing seating.

Pressed steel covers

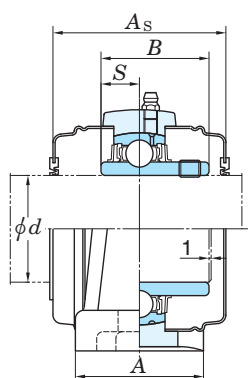

Cast iron covers

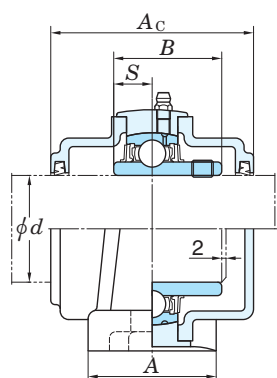

No.	Applicable bearing			Unit No. with covers				Cover dimensions (mm)		(Refer.) Unit mass (kg)	
	Basic load ratings (kN)		Factor f_0	Pressed steel covers		Cast iron covers		A_s	A_c	Pressed steel covers	Cast iron covers
	C_r	C_{0r}		Open ends	Closed end	Open ends	Closed end				
UCX20	133	105	14.4	—	—	UCPX20C	UCPX20CD	—	186	30.4	34.9
UC320	173	141	13.2	—	—	UCP320C	UCP320CD	—	174	35.1	40.7
UC321	184	153	13.2	—	—	UCP321C	UCP321CD	—	178	37.6	43.6
UC322	205	180	13.2	—	—	UCP322C	UCP322CD	—	188	44.0	50.8
UC324	207	185	13.5	—	—	UCP324C	UCP324CD	—	196	55.4	64.9
UC326	229	214	13.6	—	—	UCP326C	UCP326CD	—	214	72.1	84.2
UC328	253	246	13.6	—	—	UCP328C	UCP328CD	—	222	92.5	108

2) For bearings with double- or triple-lip seals, unit and bearing number are suffixed by L2 or L3.

3) For more detailed information, refer to ball bearing for unit specification tables.

Ball bearing units pillow block type UKP (with adapter)

d_1 20 ~ 55 mm

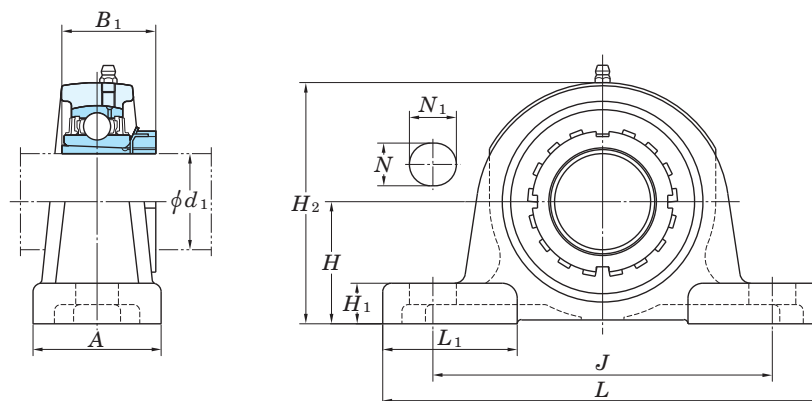

Shaft dia. (mm) d_1	Dimensions (mm)										Bolt size	Unit No.	Housing No.
	H	L	A	J	N	N_1	H_1	H_2	L_1	$B_1^{1)}$			
20	36.5	140	38	105	13	18	13	71	43	29(35)	M10	UKP205	P205
	44.4	159	51	119	17	25	16	86	47	35	M14	UKPX05	PX05
	45	175	45	132	17	20	16	85	55	35	M14	UKP305	P305
25	42.9	165	48	121	17	21	15	84	53	31(38)	M14	UKP206	P206
	47.6	175	57	127	17	25	17	93	55	38	M14	UKPX06	PX06
	50	180	50	140	17	20	17	95	53	38	M14	UKP306	P306
30	47.6	167	48	127	17	21	16	93	51	35(43)	M14	UKP207	P207
	54	203	57	144	17	30	19	105	64	43	M14	UKPX07	PX07
	56	210	56	160	17	25	19	107	65	43	M14	UKP307	P307
35	49.2	184	54	137	17	21	17	98	57	36(46)	M14	UKP208	P208
	58.7	222	67	156	20	32	21	114	71	46	M16	UKPX08	PX08
	60	220	60	170	17	27	19	118	65	46	M14	UKP308	P308
40	54	190	54	146	17	21	17	106	60	39(50)	M14	UKP209	P209
	58.7	222	67	156	20	33	21	116	71	50	M16	UKPX09	PX09
	67	245	67	190	20	30	21	132	75	50	M16	UKP309	P309
45	57.2	206	60	159	20	22	19	113	63	42(55)	M16	UKP210	P210
	63.5	241	73	171	20	36	22	126	76	55	M16	UKPX10	PX10
	75	275	75	212	20	35	24	148	88	55	M16	UKP310	P310
50	63.5	219	60	171	20	22	19	125	70	45(59)	M16	UKP211	P211
	69.8	260	79	184	25	36	28	139	83	59	M20	UKPX11	PX11
	80	310	80	236	20	38	27	158	90	59	M16	UKP311	P311
55	69.8	241	70	184	20	25	22	138	76	47(62)	M16	UKP212	P212
	76.2	286	83	203	25	40	28	152	88	62	M20	UKPX12	PX12
	85	330	85	250	25	38	29	167	103	62	M20	UKP312	P312

[Note] 1) () Shown for use triple lipseal bearing and applicable adapter No.(H2300X series).

[Remarks] 1) Applicable sizes of grease nipples are shown below.

A-1/4-28UNF 205~210, X05~X09, 305~308

A-PT 1/8 211~218, X10~X20, 309~328

Tolerance for housing

Pressed steel covers

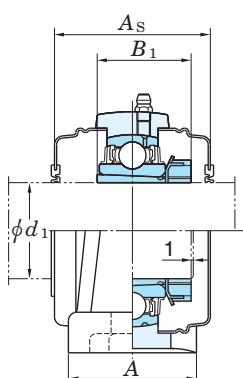

Cast iron covers

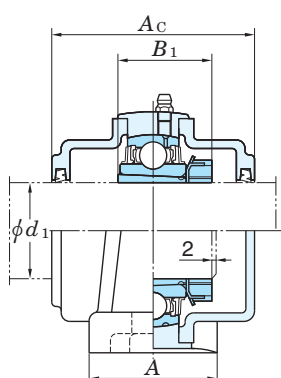

unit : mm

housing No.			ΔH_s
P205~ P210	PX05~ PX10	P305~ P310	± 0.15
P211~ P218	PX11~ PX18	P311~ P318	± 0.2
	PX20	P319~ P328	± 0.3

ΔH_s : deviation of distance from mounting base to centre of spherical bearing seating.

P205JE3 (with cast iron covers) are shown below.



No.	Applicable bearing			Applicable ¹⁾ adapter No.	Unit No. with covers				Cover dimensions (mm)		(Refer.) Unit mass (kg)	
	Basic load ratings (kN)		Factor f_0		Pressed steel covers		Cast iron covers		A_s	A_c	Pressed steel covers	Cast iron covers
	C_r	C_{0r}			Open ends	Closed end	Open ends	Closed end				
UK205 UKX05 UK305	14.0 19.5 21.2	7.85 11.3 10.9	13.9 13.9 12.6	H305X(H2305X) H2305X H2305X	UKP205C UKPX05C —	UKP205CD UKPX05CD —	UKP205FC — UKP305C	UKP205FCD — UKP305CD	48 52 —	66 — 76	0.84 1.5 1.7	1.3 — 2.3
UK206 UKX06 UK306	19.5 25.7 26.7	11.3 15.4 15.0	13.9 13.9 13.3	H306X(H2306X) H2306X H2306X	UKP206C UKPX06C —	UKP206CD UKPX06CD —	UKP206FC — UKP306C	UKP206FCD — UKP306CD	52 59 —	70 — 82	1.4 2.1 2.3	1.9 — 2.9
UK207 UKX07 UK307	25.7 29.1 33.4	15.4 17.8 19.3	13.9 14.0 13.2	H307X(H2307X) H2307X H2307X	UKP207C UKPX07C —	UKP207CD UKPX07CD —	UKP207FC — UKP307C	UKP207FCD — UKP307CD	59 68 —	78 — 88	1.7 2.7 3.0	2.5 — 3.9
UK208 UKX08 UK308	29.1 32.7 40.7	17.8 20.3 24.0	14.0 14.0 13.2	H308X(H2308X) H2308X H2308X	UKP208C UKPX08C —	UKP208CD UKPX08CD —	UKP208FC — UKP308C	UKP208FCD — UKP308CD	68 68 —	86 — 96	2.0 3.5 3.8	2.9 — 5.2
UK209 UKX09 UK309	32.7 35.1 48.9	20.3 23.3 29.5	14.0 14.4 13.3	H309X(H2309X) H2309X H2309X	UKP209C UKPX09C —	UKP209CD UKPX09CD —	UKP209FC — UKP309C	UKP209FCD — UKP309CD	68 73 —	88 — 102	2.3 3.7 5.0	3.2 — 6.3
UK210 UKX10 UK310	35.1 43.4 62.0	23.3 29.4 38.3	14.4 14.4 13.2	H310X(H2310X) H2310X H2310X	UKP210C UKPX10C —	UKP210CD UKPX10CD —	UKP210FC — UKP310C	UKP210FCD — UKP310CD	73 75 —	97 — 110	3.0 4.6 6.7	4.1 — 8.4
UK211 UKX11 UK311	43.4 52.4 71.6	29.4 36.2 45.0	14.4 14.4 13.2	H311X(H2311X) H2311X H2311X	UKP211C UKPX11C —	UKP211CD UKPX11CD —	UKP211FC — UKP311C	UKP211FCD — UKP311CD	75 88 —	99 — 114	3.7 6.2 8.1	5.0 — 10.0
UK212 UKX12 UK312	52.4 57.2 81.9	36.2 40.1 52.2	14.4 14.4 13.2	H312X(H2312X) H2312X H2312X	UKP212C UKPX12C —	UKP212CD UKPX12CD —	UKP212FC — UKP312C	UKP212FCD — UKP312CD	88 88 —	114 — 124	4.8 7.5 9.4	6.3 — 11.8

2) Unit No. means housing and bearing assembly, whole complete unit No. is given follows.

(UKP206+H306X, UK206+H306X)

3) For bearings with double- or triple-lip seals, unit and bearing number are suffixed by L2 or L3.

(UKP206JL3+H2306X, UK206L3+H2306X)

4) For more detailed information, refer to ball bearing for unit specification tables. Not applied to UKX series.

Ball bearing units pillow block type UKP (with adapter)

d_1 60 ~ 125 mm

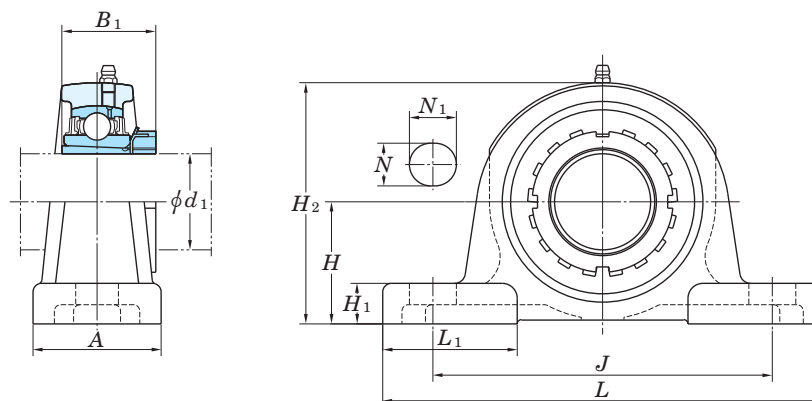

Shaft dia. (mm) d_1	Dimensions (mm)										Bolt size	Unit No.	Housing No.
	H	L	A	J	N	N_1	H_1	H_2	L_1	$B_1^{1)}$			
60	76.2	265	70	203	25	30	25	150	78	50(65)	M20	UKP213	P213
	76.2	286	83	203	25	40	28	155	88	65	M20	UKPX13	PX13
	90	340	90	260	25	38	32	176	110	65	M20	UKP313	P313
65	82.6	275	74	217	25	30	28	162	80	55(73)	M20	UKP215	P215
	88.9	330	89	229	27	50	32	175	99	73	M22	UKPX15	PX15
	100	380	100	290	27	40	35	198	107	73	M22	UKP315	P315
70	88.9	292	78	232	25	35	32	174	86	59(78)	M20	UKP216	P216
	101.6	381	102	283	27	58	34	195	116	78	M22	UKPX16	PX16
	106	400	110	300	27	40	35	209	120	78	M22	UKP316	P316
75	95.2	310	83	247	25	40	32	185	90	63(82)	M20	UKP217	P217
	101.6	381	102	283	27	60	34	200	116	82	M22	UKPX17	PX17
	112	420	110	320	33	45	40	220	120	82	M27	UKP317	P317
80	101.6	327	88	262	27	45	34	198	104	65(86)	M22	UKP218	P218
	101.6	381	111	283	27	60	38	204	116	86	M22	UKPX18	PX18
	118	430	110	330	33	45	40	234	120	86	M27	UKP318	P318
85	125	470	120	360	36	50	46	248	125	90	M30	UKP319	P319
90	127	432	121	337	33	65	45	245	126	97	M27	UKPX20	PX20
	140	490	120	380	36	50	46	273	140	97	M30	UKP320	P320
100	150	520	140	400	40	55	50	296	150	105	M33	UKP322	P322
110	160	570	140	450	40	55	50	316	160	112	M33	UKP324	P324
115	180	600	140	480	40	55	50	355	195	121	M33	UKP326	P326
125	200	620	140	500	40	55	60	393	185	131	M33	UKP328	P328

[Note] 1) () Shown for use triple lipseal bearing and applicable adapter No.(H2300X series).

[Remarks] 1) Applicable sizes of grease nipples are shown below.

A-1/4-28UNF..... 205~210, X05~X09, 305~308

A-PT 1/8 211~218, X10~X20, 309~328

Tolerance for housing

Pressed steel covers

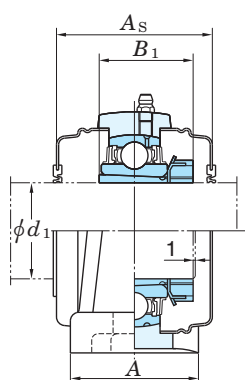

Cast iron covers

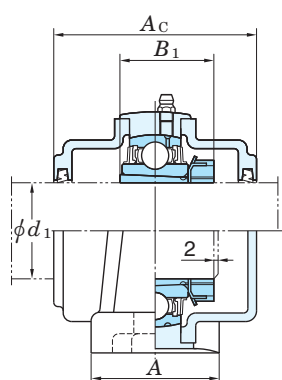

unit : mm

housing No.			ΔH_s
P205~ P210	PX05~ PX10	P305~ P310	± 0.15
P211~ P218	PX11~ PX18	P311~ P318	± 0.2
	PX20	P319~ P328	± 0.3

ΔH_s : deviation of distance from mounting base to centre of spherical bearing seating.

No.	Applicable bearing			Applicable ¹⁾ adapter No.	Unit No. with covers				Cover dimensions (mm)		(Refer.) Unit mass (kg)	
	Basic load ratings (kN)		Factor f_0		Pressed steel covers		Cast iron covers		A_s	A_c	Pressed steel covers	Cast iron covers
	C_r	C_{0r}			Open ends	Closed end	Open ends	Closed end				
UK213	57.2	40.1	14.4	H313X(H2313X)	UKP213C	UKP213CD	UKP213FC	UKP213FCD	88	114	5.8	7.5
UKX13	62.2	44.1	14.5	H2313X	UKPX13C	UKPX13CD	—	—	98	—	7.8	—
UK313	92.7	59.9	13.2	H2313X	—	—	UKP313C	UKP313CD	—	122	10.8	13.2
UK215	67.4	48.3	14.5	H315X(H2315X)	UKP215C	UKP215CD	UKP215FC	UKP215FCD	98	124	7.5	9.5
UKX15	72.7	53.0	14.6	H2315X	UKPX15C	UKPX15CD	—	—	108	—	10.5	—
UK315	113	77.2	13.2	H2315X	—	—	UKP315C	UKP315CD	—	134	14.9	17.7
UK216	72.7	53.0	14.6	H316X(H2316X)	UKP216C	UKP216CD	UKP216FC	UKP216FCD	108	138	9.2	11.7
UKX16	84.0	61.9	14.5	H2316X	UKPX16C	UKPX16CD	—	—	112	—	15.4	—
UK316	123	86.7	13.3	H2316X	—	—	UKP316C	UKP316CD	—	138	18.6	21.7
UK217	84.0	61.9	14.5	H317X(H2317X)	UKP217C	UKP217CD	UKP217FC	UKP217FCD	112	142	11.0	13.8
UKX17	96.1	71.5	14.5	H2317X	UKPX17C	UKPX17CD	—	—	122	—	15.8	—
UK317	133	96.8	13.3	H2317X	—	—	UKP317C	UKP317CD	—	146	20.2	23.7
UK218	96.1	71.5	14.5	H318X(H2318X)	UKP218C	UKP218CD	UKP218FC	UKP218FCD	122	152	13.8	18.8
UKX18	109	81.9	14.4	H2318X	—	—	UKPX18C	UKPX18CD	—	158	18.6	22.4
UK318	143	107	13.3	H2318X	—	—	UKP318C	UKP318CD	—	150	22.8	27.0
UK319	153	119	13.3	H2319X	—	—	UKP319C	UKP319CD	—	162	29.3	34.0
UKX20	133	105	14.4	H2320X	—	—	UKPX20C	UKPX20CD	—	186	29.3	34.3
UK320	173	141	13.2	H2320X	—	—	UKP320C	UKP320CD	—	174	34.8	41.0
UK322	205	180	13.2	H2322X	—	—	UKP322C	UKP322CD	—	188	43.9	50.8
UK324	207	185	13.5	H2324	—	—	UKP324C	UKP324CD	—	196	55.7	66.0
UK326	229	214	13.6	H2326	—	—	UKP326C	UKP326CD	—	214	71.9	85.2
UK328	253	246	13.6	H2328	—	—	UKP328C	UKP328CD	—	222	92.5	109

2) Unit No. means housing and bearing assembly, whole complete unit No. is given follows.
(UKP206+H306X, UK206+H306X)

3) For bearings with double- or triple-lip seals, unit and bearing number are suffixed by L2 or L3.
(UKP206JL3+H2306X, UK206L3+H2306X)

4) For more detailed information, refer to ball bearing for unit specification tables. Not applied to UKX series.

Ball bearing units

thick section pillow block type

UCIP (with set screws)

d 40 ~ 140 mm

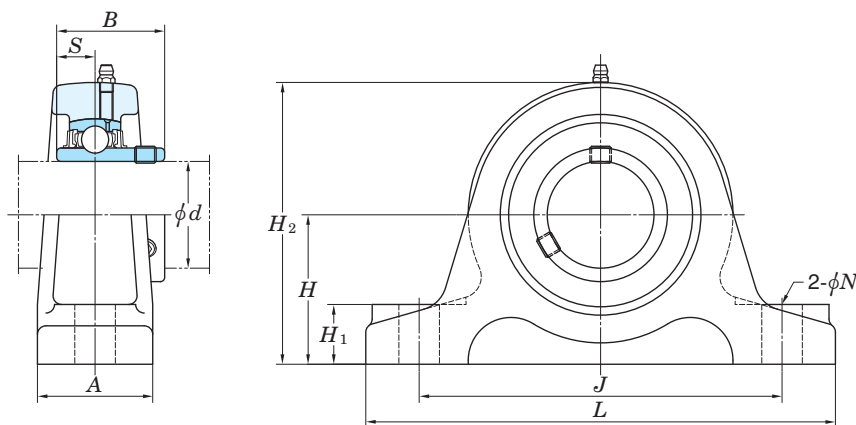

Shaft dia. (mm) d	Dimensions (mm)									Bolt size	Unit No.	Housing No.
	H	L	A	J	N	H_1	H_2	B	S			
40	60	200	60	150	19	25	115	49.2	19	M16	UCIP208	IP208
45	70	210	60	160	19	25	128	49.2	19	M16	UCIP209	IP209
50	70	220	60	170	19	28	132	51.6	19	M16	UCIP210	IP210
55	80	230	60	180	19	28	148	55.6	22.2	M16	UCIP211	IP211
60	80	260	70	200	22	30	155	65.1	25.4	M20	UCIP212	IP212
65	90 110	280 310	70 70	220 250	22 22	30 30	172 208	65.1 75	25.4 30	M20 M20	UCIP213 UCIP313	IP213 IP313
70	110	330	75	270	25	35	215	78	33	M22	UCIP314	IP314
75	120	340	75	280	25	35	230	82	32	M22	UCIP315	IP315
80	120	350	85	290	25	40	235	86	34	M22	UCIP316	IP316
85	130	370	85	310	25	40	255	96	40	M22	UCIP317	IP317
90	130	400	85	330	29	45	260	96	40	M27	UCIP318	IP318
95	150	410	85	340	29	45	285	103	41	M27	UCIP319	IP319
100	150	430	85	360	29	45	295	108	42	M27	UCIP320	IP320
110	170	490	100	410	32	50	335	117	46	M30	UCIP322	IP322
120	170	510	100	430	32	50	345	126	51	M30	UCIP324	IP324
130	200	550	110	470	32	50	390	135	54	M30	UCIP326	IP326
140	200	590	110	500	35	55	400	145	59	M33	UCIP328	IP328

[Remarks] 1) Applicable sizes of grease nipples are shown below.
 A-1/4-28UNF 208~210
 A-PT 1/8 211~213, 313~328

Tolerances for housing

unit : mm

housing No.	ΔH_s	X
IP208~ IP210	± 0.15	1
IP211~ IP213	± 0.2	1.4
IP313~ IP318	± 0.2	
IP319~ IP328	± 0.3	

ΔH_s : deviation of distance from mounting base to centre of spherical bearing seating.

X : positional tolerance of bolt hole.

Pressed steel covers

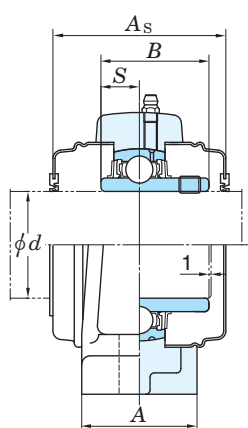

Cast iron covers

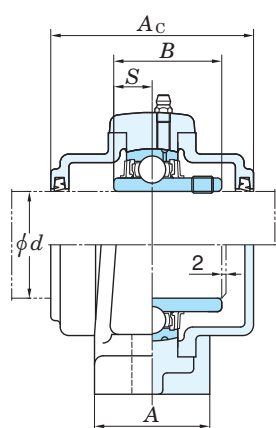

No.	Applicable bearing			Unit No. with covers				Cover dimensions (mm)		(Refer.) Unit mass (kg)	
	Basic load ratings (kN)		Factor f_0	Pressed steel covers		Cast iron covers		A_s	A_c	Pressed steel covers	Cast iron covers
	C_r	C_{or}		Open ends	Closed end	Open ends	Closed end				
UC208	29.1	17.8	14.0	UCIP208C	UCIP208CD	UCIP208FC	UCIP208FCD	68	86	3.4	4.2
UC209	32.7	20.3	14.0	UCIP209C	UCIP209CD	UCIP209FC	UCIP209FCD	68	88	3.9	4.7
UC210	35.1	23.3	14.4	UCIP210C	UCIP210CD	UCIP210FC	UCIP210FCD	73	97	4.8	5.8
UC211	43.4	29.4	14.4	UCIP211C	UCIP211CD	UCIP211FC	UCIP211FCD	75	99	5.3	6.3
UC212	52.4	36.2	14.4	UCIP212C	UCIP212CD	UCIP212FC	UCIP212FCD	88	114	7.2	8.7
UC213	57.2	40.1	14.4	UCIP213C	UCIP213CD	UCIP213FC	UCIP213FCD	88	114	8.8	10.5
UC313	92.7	59.9	13.2	—	—	UCIP313C	UCIP313CD	—	122	13.4	15.5
UC314	104	68.2	13.2	—	—	UCIP314C	UCIP314CD	—	124	15.3	17.6
UC315	113	77.2	13.2	—	—	UCIP315C	UCIP315CD	—	134	17.6	20.1
UC316	123	86.7	13.3	—	—	UCIP316C	UCIP316CD	—	138	20.3	23.2
UC317	133	96.8	13.3	—	—	UCIP317C	UCIP317CD	—	146	25.9	29.2
UC318	143	107	13.3	—	—	UCIP318C	UCIP318CD	—	150	28.6	32.4
UC319	153	119	13.3	—	—	UCIP319C	UCIP319CD	—	162	31.7	36.0
UC320	173	141	13.2	—	—	UCIP320C	UCIP320CD	—	174	36.9	42.5
UC322	205	180	13.2	—	—	UCIP322C	UCIP322CD	—	188	52.4	59.2
UC324	207	185	13.5	—	—	UCIP324C	UCIP324CD	—	196	58.7	68.2
UC326	229	214	13.6	—	—	UCIP326C	UCIP326CD	—	214	76.2	88.3
UC328	253	246	13.6	—	—	UCIP328C	UCIP328CD	—	222	87.0	102

2) Bearings with triple-lip seals are indicated by L3 after the bearing and unit number. (UCIP208JL3, UC208L3)

3) For more detailed information, refer to ball bearing for unit specification tables.

Ball bearing units

light duty pillow block type

BLP (with set screws)

d 12 ~ 40 mm

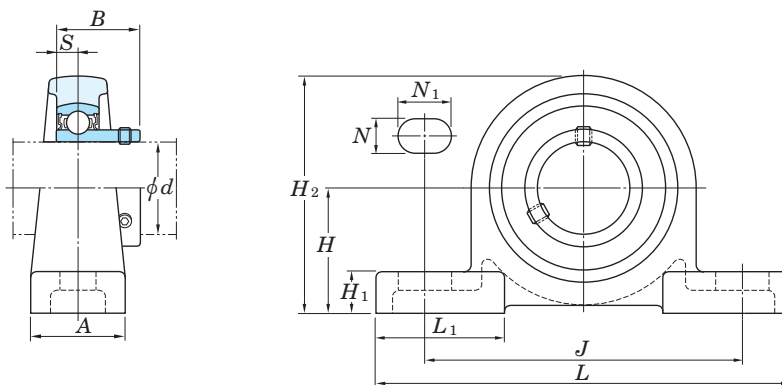

Shaft dia. (mm) d	Dimensions (mm)											Bolt size	Unit No.
	H ± 0.15	L	A	J	N	N_1	H_1	H_2	L_1	B	S		
12	30.2	114	25	87	11	16	12	57	35	22	6	M10	BLP201
15	30.2	114	25	87	11	16	12	57	35	22	6	M10	BLP202
17	30.2	114	25	87	11	16	12	57	35	22	6	M10	BLP203
20	33.3	125	27	97	11	16	13	65	38	25	7	M10	BLP204
25	36.5	130	29	100	11	16	13	71	39	27	7.5	M10	BLP205
30	42.9	156	33	120	14	21	14	83	47	30	8	M12	BLP206
35	47.6	165	35	127	14	21	16	93	50	32	8.5	M12	BLP207
40	50.8	184	37	140	14	22	18	102	55	34	9	M12	BLP208

[Remarks] 1) The radial loading on housing should not exceed 50% of the basic load rating (C_r).
 2) For more detailed information, refer to ball bearing for unit specification tables.

	Housing No.	No.	Applicable bearing		Factor f_0	(Refer.) Unit mass (kg)
			Basic load ratings (kN)			
			C_r	C_{0r}		
	LP203	SB201	9.55	4.80	13.2	0.36
	LP203	SB202	9.55	4.80	13.2	0.36
	LP203	SB203	9.55	4.80	13.2	0.36
	LP204	SB204	12.8	6.65	13.2	0.51
	LP205	SB205	14.0	7.85	13.9	0.57
	LP206	SB206	19.5	11.3	13.9	0.69
	LP207	SB207	25.7	15.4	13.9	0.94
	LP208	SB208	29.1	17.8	14.0	1.8

Ball bearing units

“compact” series pillow block type

UP (with set screws)

d 10 ~ 30 mm

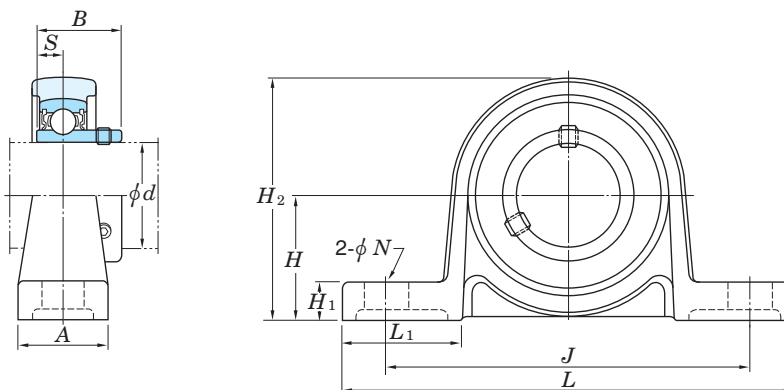

Shaft dia. (mm) d	Dimensions (mm)										Bolt size	Unit No.
	H ± 0.15	L	A	J	N ± 0.2	H_1	H_2	L_1	B	S		
10	18	67	16	53	7	6	35	18	15	5	M6	UP000
12	19	71	16	56	7	6	38	19	15	5	M6	UP001
15	22	80	16	63	7	7	43	21	16.5	5.5	M6	UP002
17	24	85	18	67	7	7	47	21	17.5	6	M6	UP003
20	28	100	20	80	10	9	55	25	21	7	M8	UP004
25	32	112	20	90	10	10	62	28	22	7	M8	UP005
30	36	132	26	106	13	11	70	34	24.5	7.5	M10	UP006

[Remarks] 1) Housing is made from special light alloy.
2) For more detailed information, refer to ball bearing for unit specification tables.

Tolerance for housing

unit : mm

housing No.	X
P000~P006	0.6

X : positional tolerance of bolt hole.

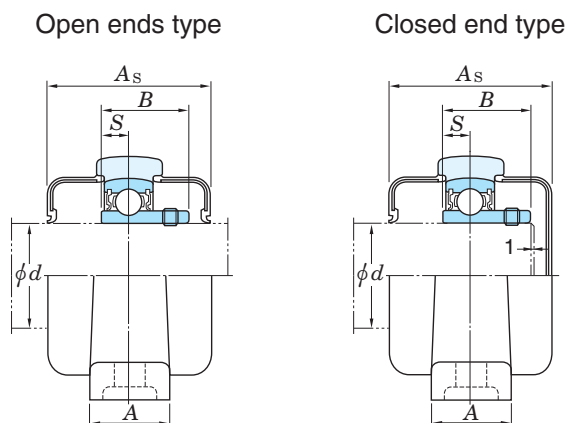

Housing No.	No.	Applicable bearing		Factor f_0	Unit No. with covers		Cover dimension (mm) A_s	(Refer.) Unit mass (kg)
		Basic load ratings (kN)			Open ends	Closed end		
		C_r	C_{0r}					
P000	SU000	4.55	1.95	12.3	UP000C	UP000CD	29	0.070
P001	SU001	5.10	2.40	13.2	UP001C	UP001CD	29	0.090
P002	SU002	5.60	2.85	13.9	UP002C	UP002CD	31	0.11
P003	SU003	6.00	3.25	14.4	UP003C	UP003CD	33	0.15
P004	SU004	9.40	5.05	13.9	UP004C	UP004CD	38	0.23
P005	SU005	10.1	5.85	14.5	UP005C	UP005CD	40	0.28
P006	SU006	13.2	8.25	14.7	UP006C	UP006CD	44	0.42

Ball bearing units

stainless-series pillow block type

UCSP-H1S6 (with set screws)

d 12 ~ 50 mm

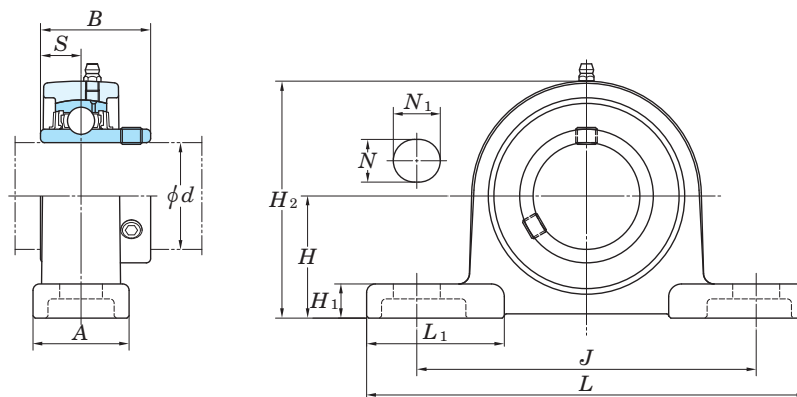

Shaft dia. (mm) d	Dimensions (mm)											Bolt size	Unit No.	Housing No.
	H ± 0.15	L	A	J	N	N_1	H_1	H_2	L_1	B	S			
12	30.2	127	30	95	13	18	11	56	42	27.4	11.5	M10	UCSP201XH1S6	SP203H1
15	30.2	127	30	95	13	18	11	56	42	27.4	11.5	M10	UCSP202XH1S6	SP203H1
17	30.2	127	30	95	13	18	11	56	42	27.4	11.5	M10	UCSP203XH1S6	SP203H1
20	33.3	127	30	95	13	18	11	63	42	31	12.7	M10	UCSP204H1S6	SP204H1
25	36.5	140	30	105	13	19	12	69	46	34.1	14.3	M10	UCSP205H1S6	SP205H1
30	42.9	165	36	121	17	21	13	81	54	38.1	15.9	M14	UCSP206H1S6	SP206H1
35	47.6	167	38	127	17	21	14	91	51	42.9	17.5	M14	UCSP207H1S6	SP207H1
40	49.2	184	40	137	17	21	14	97	60	49.2	19	M14	UCSP208H1S6	SP208H1
45	54	190	40	146	17	21	15	104	61	49.2	19	M14	UCSP209H1S6	SP209H1
50	57.2	206	45	159	20	22	16	111	65	51.6	19	M16	UCSP210H1S6	SP210H1

[Remarks] 1) Applicable size of grease nipples is A-1/4-28UNF.

Pressed stainless steel covers

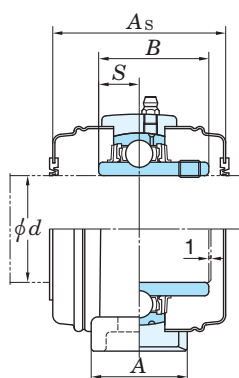

No.	Applicable bearing Basic load ratings (kN)		Factor f_0	Unit No. with covers		Cover dimension (mm) A_s	(Refer.) Unit mass (kg) Pressed steel covers
	C_r	C_{0r}		Open ends	Closed end		
UC201XS6	8.15	3.85	13.2	—	—	—	0.42
UC202XS6	8.15	3.85	13.2	—	—	—	0.42
UC203XS6	8.15	3.85	13.2	—	—	—	0.42
UC204S6	10.9	5.35	13.2	UCSP204H1CS6	UCSP204H1CDS6	45	0.54
UC205S6	11.9	6.30	13.9	UCSP205H1CS6	UCSP205H1CDS6	49	0.70
UC206S6	16.5	9.05	13.9	UCSP206H1CS6	UCSP206H1CDS6	53	1.0
UC207S6	21.8	12.3	13.9	UCSP207H1CS6	UCSP207H1CDS6	60	1.4
UC208S6	24.8	14.3	14.0	UCSP208H1CS6	UCSP208H1CDS6	69	1.7
UC209S6	27.8	16.2	14.0	UCSP209H1CS6	UCSP209H1CDS6	69	1.8
UC210S6	29.8	18.6	14.4	UCSP210H1CS6	UCSP210H1CDS6	74	2.3

2) For more detailed information, refer to ball bearing for unit specification tables.

Ball bearing units

pressed steel pillow block type

SBPP

d 12 ~ 35 mm

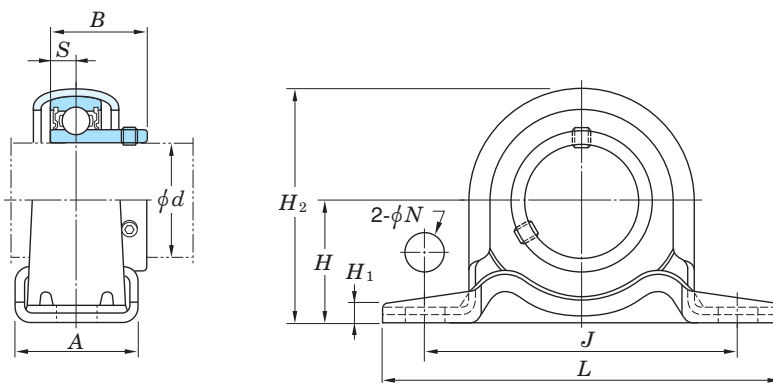

Shaft dia. (mm) d	Dimensions (mm)									Bolt size	Unit No.	Housing No.	
	H	L	A	J ± 0.4	N ± 0.5	H_1	H_2	B	S				
12	22.2	86	25	68	9.5	3.2	43.8	22	6	M8	SBPP201	PP203F	
15	22.2	86	25	68	9.5	3.2	43.8	22	6	M8	SBPP202	PP203F	
17	22.2	86	25	68	9.5	3.2	43.8	22	6	M8	SBPP203	PP203F	
20	25.4	98	32	76	9.5	3.2	50.5	25	7	M8	SBPP204	PP204F	
25	28.6	108	32	86	11.5	4	56.6	27	7.5	M10	SBPP205	PP205F	
30	33.3	117	38	95	11.5	4	66.3	30	8	M10	SBPP206	PP206F	
35	39.7	129	41	106	11.5	4.6	78	32	8.5	M10	SBPP207	PP207F	

[Remark] 1) For more detailed information, refer to ball bearing for unit specification tables.

	No.	Applicable bearing		Factor f_0	(Refer.) Unit mass (kg)
		Basic load ratings (kN)			
		C_r	C_{0r}		
	SB201	9.55	4.80	13.2	0.16
	SB202	9.55	4.80	13.2	0.16
	SB203	9.55	4.80	13.2	0.16
	SB204	12.8	6.65	13.2	0.23
	SB205	14.0	7.85	13.9	0.28
	SB206	19.5	11.3	13.9	0.47
	SB207	25.7	15.4	13.9	0.67

Ball bearing units square-flanged type UCF (with set screws)

d 12 ~ (55) mm

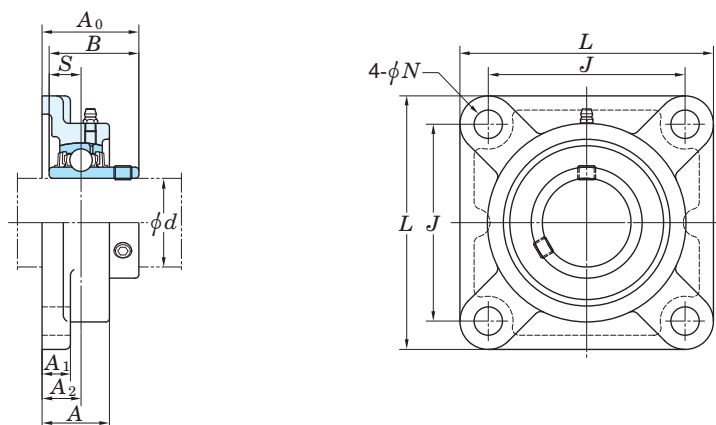

Shaft dia. (mm) d	Dimensions (mm)									Bolt size	Unit No.	Housing No.
	L	A	J	N	A_1	A_2	A_0	B	S			
12	86	25.5	64	12	11	15	33.3	31	12.7	M10	UCF201	F204
15	86	25.5	64	12	11	15	33.3	31	12.7	M10	UCF202	F204
17	86	25.5	64	12	11	15	33.3	31	12.7	M10	UCF203	F204
20	86	25.5	64	12	11	15	33.3	31	12.7	M10	UCF204	F204
25	95	27	70	12	13	16	35.8	34.1	14.3	M10	UCF205	F205
	108	30	83	12	13	18	40.2	38.1	15.9	M10	UCFX05	FX05
	110	29	80	16	13	16	39	38	15	M14	UCF305	F305
30	108	31	83	12	13	18	40.2	38.1	15.9	M10	UCF206	F206
	117	34	92	16	14	19	44.4	42.9	17.5	M14	UCFX06	FX06
	125	32	95	16	15	18	44	43	17	M14	UCF306	F306
35	117	34	92	14	15	19	44.4	42.9	17.5	M12	UCF207	F207
	130	38	102	16	14	21	51.2	49.2	19	M14	UCFX07	FX07
	135	36	100	19	16	20	49	48	19	M16	UCF307	F307
40	130	36	102	16	15	21	51.2	49.2	19	M14	UCF208	F208
	137	40	105	19	14	22	52.2	49.2	19	M16	UCFX08	FX08
	150	40	112	19	17	23	56	52	19	M16	UCF308	F308
45	137	38	105	16	16	22	52.2	49.2	19	M14	UCF209	F209
	143	40	111	19	14	23	55.6	51.6	19	M16	UCFX09	FX09
	160	44	125	19	18	25	60	57	22	M16	UCF309	F309
50	143	40	111	16	16	22	54.6	51.6	19	M14	UCF210	F210
	162	44	130	19	20	26	59.4	55.6	22.2	M16	UCFX10	FX10
	175	48	132	23	19	28	67	61	22	M20	UCF310	F310
55	162	43	130	19	18	25	58.4	55.6	22.2	M16	UCF211	F211

[Remarks] 1) Applicable sizes of grease nipples are shown below.
 A-1/4-28UNF 201~210, X05~X09, 305~308
 A-PT 1/8 211~218, X10~X20, 309~328

Pressed steel cover

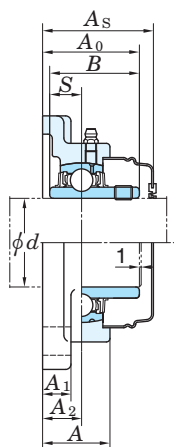

Cast iron cover

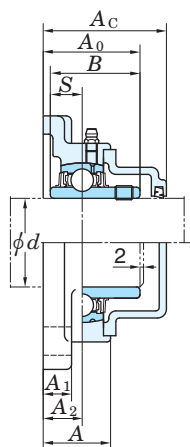

Tolerances for housing

unit : mm

housing No.			ΔA_{2s}	X
F204~ F210	FX05~ FX10	F305~ F310	± 0.5	0.7
F211~ F218	FX11~ FX20	F311~ F328	± 0.8	1

ΔA_{2s} : deviation of distance from mounting face to centre of spherical bearing seating.

X : positional tolerance of bolt hole.

unit : mm

housing No.			ΔN_s
F204~ F218	FX05~ FX18	F305~ F315	± 0.2
	FX20	F316~ F328	± 0.3

ΔN_s : deviation of bolt hole diameter.

No.	Applicable bearing			Unit No. with covers				Cover dimensions (mm)		(Refer.) Unit mass (kg)	
	Basic load ratings (kN)		Factor f_0	Pressed steel covers		Cast iron covers		A_s	A_c	Pressed steel covers	Cast iron covers
	C_r	C_{0r}		Open ends	Closed end	Open ends	Closed end				
UC201	12.8	6.65	13.2	UCF201C	UCF201D	—	—	37	—	0.64	—
UC202	12.8	6.65	13.2	UCF202C	UCF202D	—	—	37	—	0.62	—
UC203	12.8	6.65	13.2	UCF203C	UCF203D	—	—	37	—	0.61	—
UC204	12.8	6.65	13.2	UCF204C	UCF204D	UCF204FC	UCF204FD	37	46	0.59	0.74
UC205	14.0	7.85	13.9	UCF205C	UCF205D	UCF205FC	UCF205FD	40	49	0.83	1.0
UCX05	19.5	11.3	13.9	UCFX05C	UCFX05D	—	—	44	—	1.2	—
UC305	21.2	10.9	12.6	—	—	UCF305C	UCF305D	—	54	1.3	1.6
UC206	19.5	11.3	13.9	UCF206C	UCF206D	UCF206FC	UCF206FD	44	53	1.1	1.4
UCX06	25.7	15.4	13.9	UCFX06C	UCFX06D	—	—	49	—	1.6	—
UC306	26.7	15.0	13.3	—	—	UCF306C	UCF306D	—	59	1.9	2.2
UC207	25.7	15.4	13.9	UCF207C	UCF207D	UCF207FC	UCF207FD	49	58	1.5	1.9
UCX07	29.1	17.8	14.0	UCFX07C	UCFX07D	—	—	55	—	2.0	—
UC307	33.4	19.3	13.2	—	—	UCF307C	UCF307D	—	64	2.3	2.7
UC208	29.1	17.8	14.0	UCF208C	UCF208D	UCF208FC	UCF208FD	55	64	1.9	2.3
UCX08	32.7	20.3	14.0	UCFX08C	UCFX08D	—	—	56	—	2.4	—
UC308	40.7	24.0	13.2	—	—	UCF308C	UCF308D	—	71	3.1	3.6
UC209	32.7	20.3	14.0	UCF209C	UCF209D	UCF209FC	UCF209FD	56	66	2.2	2.6
UCX09	35.1	23.3	14.4	UCFX09C	UCFX09D	—	—	60	—	2.7	—
UC309	48.9	29.5	13.3	—	—	UCF309C	UCF309D	—	76	4.0	4.6
UC210	35.1	23.3	14.4	UCF210C	UCF210D	UCF210FC	UCF210FD	59	70.5	2.5	3.0
UCX10	43.4	29.4	14.4	UCFX10C	UCFX10D	—	—	64	—	3.7	—
UC310	62.0	38.3	13.2	—	—	UCF310C	UCF310D	—	83	5.1	5.9
UC211	43.4	29.4	14.4	UCF211C	UCF211D	UCF211FC	UCF211FD	63	74.5	3.4	4.0

2) For bearings with double- or triple-lip seals, unit and bearing number are suffixed by L2 or L3.
(UCF206JL3, UC206L3)

3) For more detailed information, refer to ball bearing for unit specification tables.

Ball bearing units square-flanged type UCF (with set screws)

d (55) ~ 95 mm

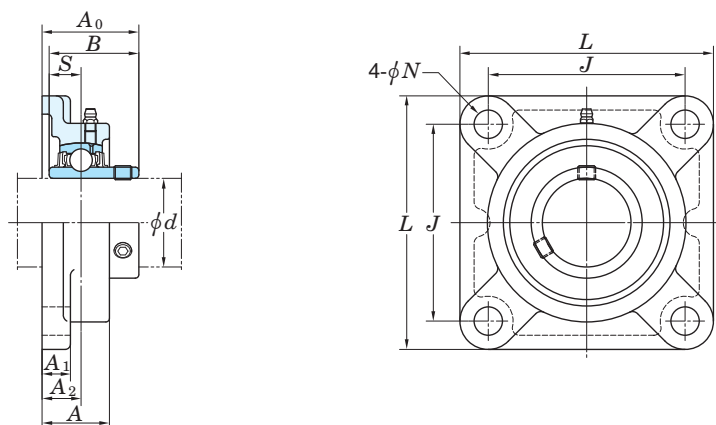

Shaft dia. (mm) d	Dimensions (mm)									Bolt size	Unit No.	Housing No.	
	L	A	J	N	A_1	A_2	A_0	B	S				
55	175	49	143	19	20	29	68.7	65.1	25.4	M16	UCFX11	FX11	
	185	52	140	23	20	30	71	66	25	M20	UCF311	F311	
60	175	48	143	19	18	29	68.7	65.1	25.4	M16	UCF212	F212	
	187	59	149	19	21	34	73.7	65.1	25.4	M16	UCFX12	FX12	
	195	56	150	23	22	33	78	71	26	M20	UCF312	F312	
65	187	50	149	19	22	30	69.7	65.1	25.4	M16	UCF213	F213	
	187	59	149	19	21	34	78.4	74.6	30.2	M16	UCFX13	FX13	
	208	58	166	23	22	33	78	75	30	M20	UCF313	F313	
70	193	54	152	19	22	31	75.4	74.6	30.2	M16	UCF214	F214	
	197	60	152	23	22	37	81.5	77.8	33.3	M20	UCFX14	FX14	
	226	61	178	25	25	36	81	78	33	M22	UCF314	F314	
75	200	56	159	19	22	34	78.5	77.8	33.3	M16	UCF215	F215	
	197	68	152	23	24	40	89.3	82.6	33.3	M20	UCFX15	FX15	
	236	66	184	25	25	39	89	82	32	M22	UCF315	F315	
80	208	58	165	23	22	34	83.3	82.6	33.3	M20	UCF216	F216	
	214	70	171	23	24	40	91.6	85.7	34.1	M20	UCFX16	FX16	
	250	68	196	31	27	38	90	86	34	M27	UCF316	F316	
85	220	63	175	23	24	36	87.6	85.7	34.1	M20	UCF217	F217	
	214	70	171	23	24	40	96.3	96	39.7	M20	UCFX17	FX17	
	260	74	204	31	27	44	100	96	40	M27	UCF317	F317	
90	235	68	187	23	25	40	96.3	96	39.7	M20	UCF218	F218	
	214	76	171	23	24	45	106.1	104	42.9	M20	UCFX18	FX18	
	280	76	216	35	30	44	100	96	40	M30	UCF318	F318	
95	290	94	228	35	30	59	121	103	41	M30	UCF319	F319	

[Remarks] 1) Applicable sizes of grease nipples are shown below.
 A-1/4-28UNF 201~210, X05~X09, 305~308
 A-PT 1/8 211~218, X10~X20, 309~328

Pressed steel cover

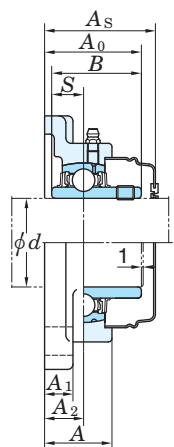

Cast iron cover

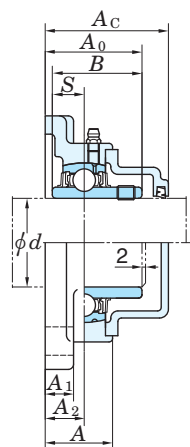

Tolerances for housing

unit : mm

housing No.			ΔA_{2s}	X
F204~ F210	FX05~ FX10	F305~ F310	± 0.5	0.7
F211~ F218	FX11~ FX20	F311~ F328	± 0.8	1

ΔA_{2s} : deviation of distance from mounting face to centre of spherical bearing seating.

X : positional tolerance of bolt hole.

unit : mm

housing No.			ΔN_s
F204~ F218	FX05~ FX18	F305~ F315	± 0.2
	FX20	F316~ F328	± 0.3

ΔN_s : deviation of bolt hole diameter.

No.	Applicable bearing			Unit No. with covers				Cover dimensions (mm)		(Refer.) Unit mass (kg)	
	Basic load ratings (kN)		Factor f_0	Pressed steel covers		Cast iron covers		A_s	A_c	Pressed steel covers	Cast iron covers
	C_r	C_{0r}		Open ends	Closed end	Open ends	Closed end				
UCX11	52.4	36.2	14.4	UCFX11C	UCFX11D	—	—	73	—	4.9	—
UC311	71.6	45.0	13.2	—	—	UCF311C	UCF311D	—	87	5.6	6.5
UC212	52.4	36.2	14.4	UCF212C	UCF212D	UCF212FC	UCF212FD	73	86	4.2	5.0
UCX12	57.2	40.1	14.4	UCFX12C	UCFX12D	—	—	78	—	5.7	—
UC312	81.9	52.2	13.2	—	—	UCF312C	UCF312D	—	95	6.9	8.1
UC213	57.2	40.1	14.4	UCF213C	UCF213D	UCF213FC	UCF213FD	74	87	5.2	6.0
UCX13	62.2	44.1	14.5	UCFX13C	UCFX13D	—	—	83	—	6.3	—
UC313	92.7	59.9	13.2	—	—	UCF313C	UCF313D	—	94	7.8	8.9
UC214	62.2	44.1	14.5	UCF214C	UCF214D	UCF214FC	UCF214FD	80	93	5.9	6.8
UCX14	67.4	48.3	14.5	UCFX14C	UCFX14D	—	—	86	—	7.0	—
UC314	104	68.2	13.2	—	—	UCF314C	UCF314D	—	98	10.1	11.2
UC215	67.4	48.3	14.5	UCF215C	UCF215D	UCF215FC	UCF215FD	83	96	6.4	7.4
UCX15	72.7	53.0	14.6	UCFX15C	UCFX15D	—	—	94	—	8.4	—
UC315	113	77.2	13.2	—	—	UCF315C	UCF315D	—	106	11.6	12.9
UC216	72.7	53.0	14.6	UCF216C	UCF216D	UCF216FC	UCF216FD	88	103	7.3	8.5
UCX16	84.0	61.9	14.5	UCFX16C	UCFX16D	—	—	96	—	9.4	—
UC316	123	86.7	13.3	—	—	UCF316C	UCF316D	—	107	12.8	14.2
UC217	84.0	61.9	14.5	UCF217C	UCF217D	UCF217FC	UCF217FD	92	107	8.9	10.3
UCX17	96.1	71.5	14.5	UCFX17C	UCFX17D	—	—	101	—	10.8	—
UC317	133	96.8	13.3	—	—	UCF317C	UCF317D	—	117	15.3	16.9
UC218	96.1	71.5	14.5	UCF218C	UCF218D	UCF218FC	UCF218FD	101	116	11.4	12.9
UCX18	109	81.9	14.4	—	—	UCFX18C	UCFX18D	—	124	11.9	13.6
UC318	143	107	13.3	—	—	UCF318C	UCF318D	—	119	18.9	20.8
UC319	153	119	13.3	—	—	UCF319C	UCF319D	—	140	21.6	23.8

2) For bearings with double- or triple-lip seals, unit and bearing number are suffixed by L2 or L3. (UCF206JL3, UC206L3)

3) For more detailed information, refer to ball bearing for unit specification tables.

Ball bearing units square-flanged type UCF (with set screws)

d 100 ~ 140 mm

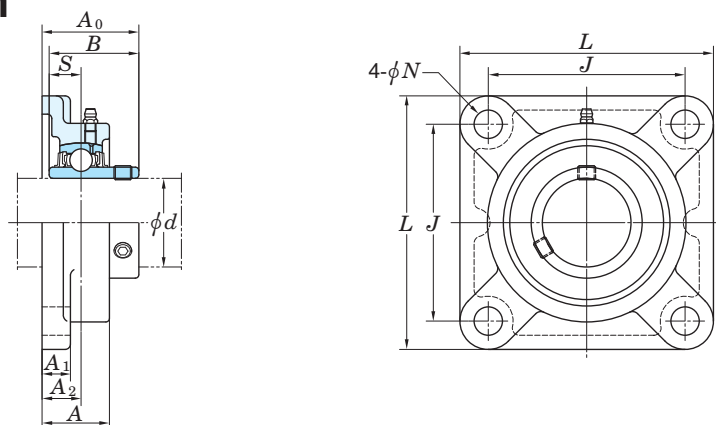

Shaft dia. (mm) d	Dimensions (mm)									Bolt size	Unit No.	Housing No.
	L	A	J	N	A_1	A_2	A_0	B	S			
100	268	97	211	31	28	59	127.3	117.5	49.2	M27	UCFX20	FX20
	310	94	242	38	32	59	125	108	42	M33	UCF320	F320
105	310	94	242	38	32	59	127	112	44	M33	UCF321	F321
110	340	96	266	41	35	60	131	117	46	M36	UCF322	F322
120	370	110	290	41	40	65	140	126	51	M36	UCF324	F324
130	410	115	320	41	45	65	146	135	54	M36	UCF326	F326
140	450	125	350	41	55	75	161	145	59	M36	UCF328	F328

[Remarks] 1) Applicable sizes of grease nipples are shown below.
 A-1/4-28UNF 201~210, X05~X09, 305~308
 A-PT 1/8 211~218, X10~X20, 309~328

Pressed steel cover

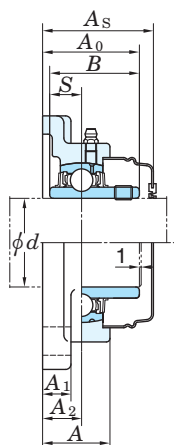

Cast iron cover

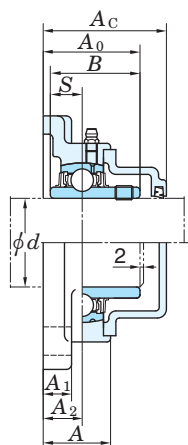

Tolerances for housing

unit : mm

housing No.			ΔA_{2s}	X
F204~ F210	FX05~ FX10	F305~ F310	± 0.5	0.7
F211~ F218	FX11~ FX20	F311~ F328	± 0.8	1

ΔA_{2s} : deviation of distance from mounting face to centre of spherical bearing seating.

X : positional tolerance of bolt hole.

unit : mm

housing No.			ΔN_s
F204~ F218	FX05~ FX18	F305~ F315	± 0.2
	FX20	F316~ F328	± 0.3

ΔN_s : deviation of bolt hole diameter.

No.	Applicable bearing			Unit No. with covers				Cover dimensions (mm)		(Refer.) Unit mass (kg)	
	Basic load ratings (kN)		Factor f_0	Pressed steel covers		Cast iron covers		A_s	A_c	Pressed steel covers	Cast iron covers
	C_r	C_{0r}		Open ends	Closed end	Open ends	Closed end				
UCX20	133	105	14.4	—	—	UCFX20C	UCFX20D	—	152	19.4	21.6
UC320	173	141	13.2	—	—	UCF320C	UCF320D	—	146	25.8	28.6
UC321	184	153	13.2	—	—	UCF321C	UCF321D	—	148	30.2	33.2
UC322	205	180	13.2	—	—	UCF322C	UCF322D	—	154	35.3	41.7
UC324	207	185	13.5	—	—	UCF324C	UCF324D	—	163	47.3	52.1
UC326	229	214	13.6	—	—	UCF326C	UCF326D	—	172	65.5	71.6
UC328	253	246	13.6	—	—	UCF328C	UCF328D	—	186	93.4	101

2) For bearings with double- or triple-lip seals, unit and bearing number are suffixed by L2 or L3. (UCF206JL3, UC206L3)

3) For more detailed information, refer to ball bearing for unit specification tables.

Ball bearing units

square-flanged type with spigot joint

UCFS (with set screws)

d 25 ~ 105 mm

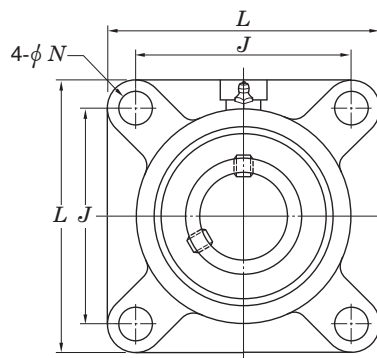
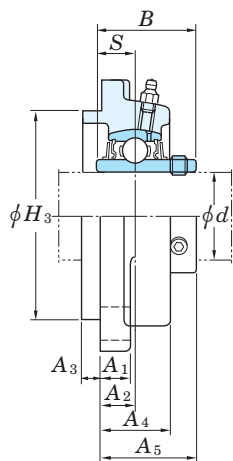

Shaft dia. (mm) d	Dimensions (mm)											Bolt size	Unit No.	Housing No.
	L	H_3	J	N	A_1	A_2	A_3	A_4	A_5	B	S			
25	110	80	80	16	13	9	7	22	32	38	15	M14	UCFS305	FS305
30	125	90	95	16	15	10	8	24	36	43	17	M14	UCFS306	FS306
35	135	100	100	19	16	11	9	27	40	48	19	M16	UCFS307	FS307
40	150	115	112	19	17	13	10	30	46	52	19	M16	UCFS308	FS308
45	160	125	125	19	18	14	11	33	49	57	22	M16	UCFS309	FS309
50	175	140	132	23	19	16	12	36	55	61	22	M20	UCFS310	FS310
55	185	150	140	23	20	17	13	39	58	66	25	M20	UCFS311	FS311
60	195	160	150	23	22	19	14	42	64	71	26	M20	UCFS312	FS312
65	208	175	166	23	22	15	18	40	60	75	30	M20	UCFS313	FS313
70	226	185	178	25	25	18	18	43	63	78	33	M22	UCFS314	FS314
75	236	200	184	25	25	21	18	48	71	82	32	M22	UCFS315	FS315
80	250	210	196	31	27	18	20	48	70	86	34	M27	UCFS316	FS316
85	260	220	204	31	27	24	20	54	80	96	40	M27	UCFS317	FS317
90	280	240	216	35	30	24	20	56	80	96	40	M30	UCFS318	FS318
95	290	250	228	35	30	39	20	74	101	103	41	M30	UCFS319	FS319
100	310	260	242	38	32	39	20	74	105	108	42	M33	UCFS320	FS320
105	310	260	242	38	32	39	20	74	107	112	44	M33	UCFS321	FS321

[Remarks] 1) Applicable sizes of grease nipples are shown below.
A-1/4-28UNF..... 305~308
A-PT 1/8 309~328

Cast iron cover

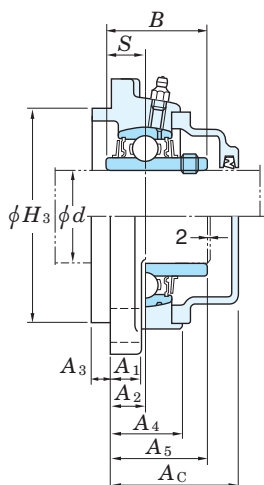

Tolerances for housing

unit : mm

housing No.	ΔH_{3s}	ΔA_{2s}	X	Y
FS305	0 -0.046	±0.5	0.7	0.2
FS306~ FS308	0 -0.054			
FS309~ FS310	0 -0.063			
FS311~ FS313	0 -0.063	±0.8	1	0.3
FS314~ FS319	0 -0.072			~FS318
FS320~ FS322	0 -0.081			FS319~
FS324~ FS328	0 -0.089			0.4

unit : mm

housing No.	ΔN_s
FS305~315	±0.2
FS316~328	±0.3

ΔN_s : deviation of bolt hole diameter.

ΔH_{3s} : deviation of spigot joint outside diameter.

ΔA_{2s} : deviation of distance from mounting face to centre of spherical bearing seating.

X : positional tolerance of bolt hole.

Y : circumferential runout tolerance of spigot joint in respect to axial line of spherical bearing seating.

No.	Applicable bearing		Factor f_0	Unit No. with covers		Cover dimensions (mm) A_c	(Refer.) Unit mass (kg)	
	Basic load ratings (kN) C_r	C_{0r}		Open ends	Closed end		No cover	Cast iron covers
UC305	21.2	10.9	12.6	UCFS305C	UCFS305D	47	1.4	1.7
UC306	26.7	15.0	13.3	UCFS306C	UCFS306D	51	1.9	2.2
UC307	33.4	19.3	13.2	UCFS307C	UCFS307D	55	2.3	2.7
UC308	40.7	24.0	13.2	UCFS308C	UCFS308D	61	3.4	3.9
UC309	48.9	29.5	13.3	UCFS309C	UCFS309D	65	4.4	5.0
UC310	62.0	38.3	13.2	UCFS310C	UCFS310D	71	5.3	6.1
UC311	71.6	45.0	13.2	UCFS311C	UCFS311D	74	6.1	7.0
UC312	81.9	52.2	13.2	UCFS312C	UCFS312D	81	7.4	8.6
UC313	92.7	59.9	13.2	UCFS313C	UCFS313D	76	8.8	9.9
UC314	104	68.2	13.2	UCFS314C	UCFS314D	80	11.2	12.3
UC315	113	77.2	13.2	UCFS315C	UCFS315D	88	13.7	15.0
UC316	123	86.7	13.3	UCFS316C	UCFS316D	87	15.1	16.5
UC317	133	96.8	13.3	UCFS317C	UCFS317D	97	17.3	18.9
UC318	143	107	13.3	UCFS318C	UCFS318D	99	21.3	23.2
UC319	153	119	13.3	UCFS319C	UCFS319D	120	24.5	26.7
UC320	173	141	13.2	UCFS320C	UCFS320D	126	29.5	32.3
UC321	184	153	13.2	UCFS321C	UCFS321D	128	32.7	35.7

2) Bearings with triple-lip seals are indicated by L3 after the bearing and unit number.
(UCFS307JL3, UC307L3)

3) For more detailed information, refer to ball bearing for unit specification tables.

Ball bearing units

square-flanged type with spigot joint

UCFS (with set screws)

d 110 ~ 140 mm

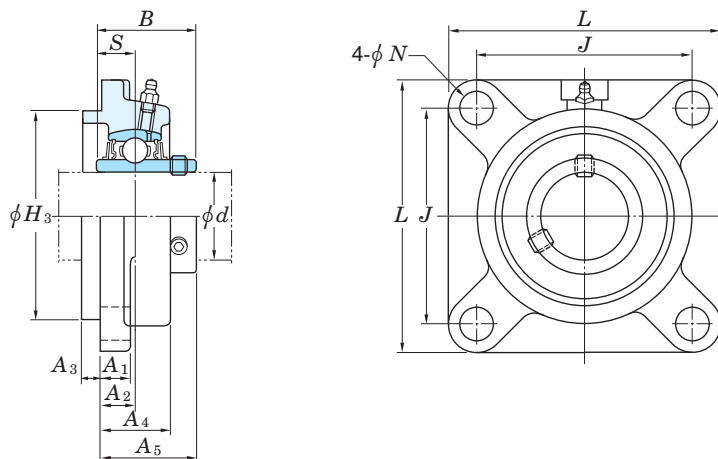

Shaft dia. (mm) d	Dimensions (mm)											Bolt size	Unit No.	Housing No.
	L	H_3	J	N	A_1	A_2	A_3	A_4	A_5	B	S			
110	340	300	266	41	35	35	25	71	106	117	46	M36	UCFS322	FS322
120	370	330	290	41	40	35	30	80	110	126	51	M36	UCFS324	FS324
130	410	360	320	41	45	35	30	85	116	135	54	M36	UCFS326	FS326
140	450	400	350	41	55	45	30	95	131	145	59	M36	UCFS328	FS328

[Remarks] 1) Applicable sizes of grease nipples are shown below.
 A-1/4-28UNF..... 305~308
 A-PT 1/8 309~328

Cast iron cover

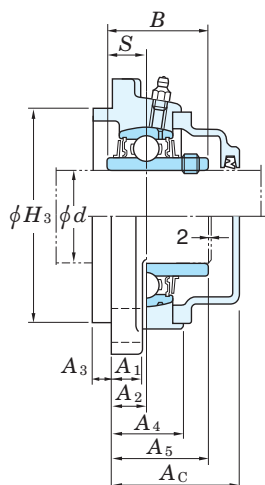

Tolerances for housing

unit : mm

housing No.	ΔH_{3s}	ΔA_{2s}	X	Y
FS305	0 -0.046	±0.5	0.7	0.2
FS306~ FS308	0 -0.054			
FS309~ FS310	0 -0.063			
FS311~ FS313	0 -0.063	±0.8	1	0.3
FS314~ FS319	0 -0.072			~FS318
FS320~ FS322	0 -0.081			FS319~
FS324~ FS328	0 -0.089			0.4

unit : mm

housing No.	ΔN_s
FS305~315	±0.2
FS316~328	±0.3

ΔN_s : deviation of bolt hole diameter.

ΔH_{3s} : deviation of spigot joint outside diameter.

ΔA_{2s} : deviation of distance from mounting face to centre of spherical bearing seating.

X : positional tolerance of bolt hole.

Y : circumferential runout tolerance of spigot joint in respect to axial line of spherical bearing seating.

No.	Applicable bearing		Factor f_0	Unit No. with covers		Cover dimensions (mm) A_c	(Refer.) Unit mass (kg)	
	Basic load ratings (kN) C_r	C_{0r}		Open ends	Closed end		No cover	Cast iron covers
UC322	205	180	13.2	UCFS322C	UCFS322D	129	39.0	42.4
UC324	207	185	13.5	UCFS324C	UCFS324D	133	50.6	55.4
UC326	229	214	13.6	UCFS326C	UCFS326D	142	67.7	73.8
UC328	253	246	13.6	UCFS328C	UCFS328D	156	94.0	102

2) Bearings with triple-lip seals are indicated by L3 after the bearing and unit number.
(UCFS307JL3, UC307L3)

3) For more detailed information, refer to ball bearing for unit specification tables.

Ball bearing units rhombic-flanged type UCFL (with set screws)

d 12 ~ 55 mm

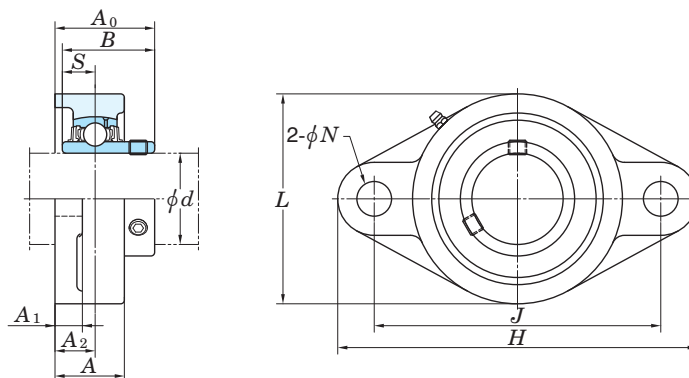

Shaft dia. (mm) d	Dimensions (mm)										Bolt size	Unit No.	Housing No.
	H	L	A	J	N	A_1	A_2	A_0	B	S			
12	113	60	25.5	90	12	11	15	33.3	31	12.7	M10	UCFL201	FL204
15	113	60	25.5	90	12	11	15	33.3	31	12.7	M10	UCFL202	FL204
17	113	60	25.5	90	12	11	15	33.3	31	12.7	M10	UCFL203	FL204
20	113	60	25.5	90	12	11	15	33.3	31	12.7	M10	UCFL204	FL204
25	130	68	27	99	16	13	16	35.8	34.1	14.3	M14	UCFL205	FL205
	141	83	30	117	12	13	18	40.2	38.1	15.9	M10	UCFLX05	FLX05
	150	80	29	113	19	13	16	39	38	15	M16	UCFL305	FL305
30	148	80	31	117	16	13	18	40.2	38.1	15.9	M14	UCFL206	FL206
	156	95	34	130	16	14	19	44.4	42.9	17.5	M14	UCFLX06	FLX06
	180	90	32	134	23	15	18	44	43	17	M20	UCFL306	FL306
35	161	90	34	130	16	14	19	44.4	42.9	17.5	M14	UCFL207	FL207
	171	105	38	144	16	14	21	51.2	49.2	19	M14	UCFLX07	FLX07
	185	100	36	141	23	16	20	49	48	19	M20	UCFL307	FL307
40	175	100	36	144	16	14	21	51.2	49.2	19	M14	UCFL208	FL208
	179	111	40	148	16	14	22	52.2	49.2	19	M14	UCFLX08	FLX08
	200	112	40	158	23	17	23	56	52	19	M20	UCFL308	FL308
45	188	108	38	148	19	15	22	52.2	49.2	19	M16	UCFL209	FL209
	189	116	40	157	16	14	23	55.6	51.6	19	M14	UCFLX09	FLX09
	230	125	44	177	25	18	25	60	57	22	M22	UCFL309	FL309
50	197	115	40	157	19	15	22	54.6	51.6	19	M16	UCFL210	FL210
	216	133	44	184	19	20	26	59.4	55.6	22.2	M16	UCFLX10	FLX10
	240	140	48	187	25	19	28	67	61	22	M22	UCFL310	FL310
55	224	130	43	184	19	18	25	58.4	55.6	22.2	M16	UCFL211	FL211
	250	150	52	198	25	20	30	71	66	25	M22	UCFL311	FL311

[Remarks] 1) Applicable sizes of grease nipples are shown below.
 A-1/4-28UNF..... 201~210, X05~X09, 305~308
 A-PT 1/8 211~217, X10~X17, 309~328

Tolerances for housing

Pressed steel cover

Cast iron cover

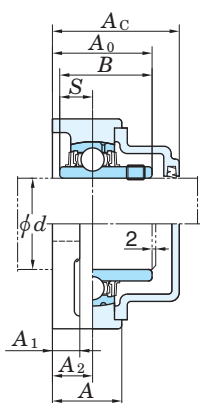
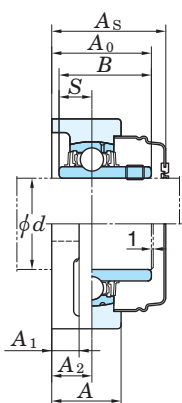

housing No.			ΔN_s
FL204~ FL218	FLX05~ FLX10	FL305~ FL311	± 0.2
		FL312~ FL328	± 0.3

housing No.			ΔA_{2s}	X
FL204~ FL210	FLX05~ FLX10	FL305~ FL310	± 0.5	0.7
FL211~ FL218		FL311~ FL328	± 0.8	1

ΔN_s : deviation of bolt hole diameter.

ΔA_{2s} : deviation of distance from mounting face to centre of spherical bearing seating.

X : positional tolerance of bolt hole.

FL204JE3, FL205JE3 (with cast iron covers) are shown below.

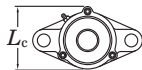

FL204JE3 $L_c = 65$ mm
FL205JE3 $L_c = 73$ mm

No.	Applicable bearing			Unit No. with covers				Cover dimensions (mm)		(Refer.) Unit mass (kg)	
	Basic load ratings (kN)		Factor f_0	Pressed steel covers		Cast iron covers		A_s	A_c	Pressed steel covers	Cast iron covers
	C_r	C_{0r}		Open ends	Closed end	Open ends	Closed end				
UC201	12.8	6.65	13.2	UCFL201C	UCFL201D	—	—	37	—	0.50	—
UC202	12.8	6.65	13.2	UCFL202C	UCFL202D	—	—	37	—	0.48	—
UC203	12.8	6.65	13.2	UCFL203C	UCFL203D	—	—	37	—	0.47	—
UC204	12.8	6.65	13.2	UCFL204C	UCFL204D	UCFL204FC	UCFL204FD	37	46	0.45	0.60
UC205	14.0	7.85	13.9	UCFL205C	UCFL205D	UCFL205FC	UCFL205FD	40	49	0.64	0.83
UCX05	19.5	11.3	13.9	UCFLX05C	UCFLX05D	—	—	44	—	1.1	—
UC305	21.2	10.9	12.6	—	—	UCFL305C	UCFL305D	—	54	1.1	1.4
UC206	19.5	11.3	13.9	UCFL206C	UCFL206D	UCFL206FC	UCFL206FD	44	53	0.93	1.2
UCX06	25.7	15.4	13.9	UCFLX06C	UCFLX06D	—	—	49	—	1.5	—
UC306	26.7	15.0	13.3	—	—	UCFL306C	UCFL306D	—	59	1.5	1.8
UC207	25.7	15.4	13.9	UCFL207C	UCFL207D	UCFL207FC	UCFL207FD	49	58	1.2	1.6
UCX07	29.1	17.8	14.0	UCFLX07C	UCFLX07D	—	—	55	—	1.9	—
UC307	33.4	19.3	13.2	—	—	UCFL307C	UCFL307D	—	64	1.8	2.2
UC208	29.1	17.8	14.0	UCFL208C	UCFL208D	UCFL208FC	UCFL208FD	55	64	1.6	2.0
UCX08	32.7	20.3	14.0	UCFLX08C	UCFLX08D	—	—	56	—	2.1	—
UC308	40.7	24.0	13.2	—	—	UCFL308C	UCFL308D	—	71	2.5	3.0
UC209	32.7	20.3	14.0	UCFL209C	UCFL209D	UCFL209FC	UCFL209FD	56	66	1.9	2.3
UCX09	35.1	23.3	14.4	UCFLX09C	UCFLX09D	—	—	60	—	2.4	—
UC309	48.9	29.5	13.3	—	—	UCFL309C	UCFL309D	—	76	3.5	4.1
UC210	35.1	23.3	14.4	UCFL210C	UCFL210D	UCFL210FC	UCFL210FD	59	70.5	2.2	2.7
UCX10	43.4	29.4	14.4	UCFLX10C	UCFLX10D	—	—	64	—	3.8	—
UC310	62.0	38.3	13.2	—	—	UCFL310C	UCFL310D	—	83	4.4	5.2
UC211	43.4	29.4	14.4	UCFL211C	UCFL211D	UCFL211FC	UCFL211FD	63	74.5	3.3	3.9
UC311	71.6	45.0	13.2	—	—	UCFL311C	UCFL311D	—	87	5.3	6.2

2) Bearings with triple-lip seals are indicated by L3 after the bearing and unit number. (UCFS307JL3, UC307L3)

3) For more detailed information, refer to ball bearing for unit specification tables.

Ball bearing units

rhombic-flanged type

UCFL (with set screws)

d 60 ~ 140 mm

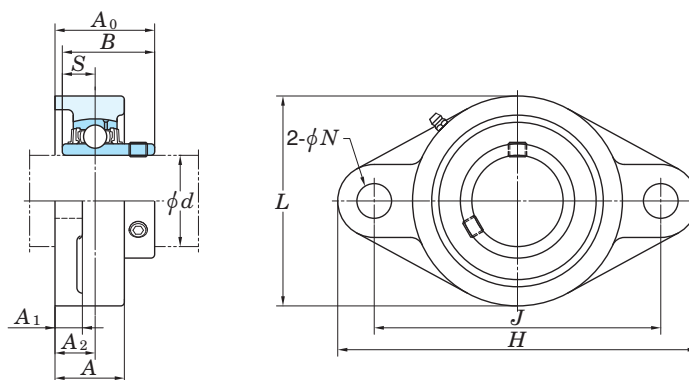

Shaft dia. (mm) d	Dimensions (mm)										Bolt size	Unit No.	Housing No.
	H	L	A	J	N	A_1	A_2	A_0	B	S			
60	250	140	48	202	23	18	29	68.7	65.1	25.4	M20	UCFL212	FL212
	270	160	56	212	31	22	33	78	71	26	M27	UCFL312	FL312
65	258	155	50	210	23	20	30	69.7	65.1	25.4	M20	UCFL213	FL213
	295	175	58	240	31	25	33	78	75	30	M27	UCFL313	FL313
70	265	160	54	216	23	20	31	75.4	74.6	30.2	M20	UCFL214	FL214
	315	185	61	250	35	28	36	81	78	33	M30	UCFL314	FL314
75	275	165	56	225	23	20	34	78.5	77.8	33.3	M20	UCFL215	FL215
	320	195	66	260	35	30	39	89	82	32	M30	UCFL315	FL315
80	290	180	58	233	25	20	34	83.3	82.6	33.3	M22	UCFL216	FL216
	355	210	68	285	38	32	38	90	86	34	M33	UCFL316	FL316
85	305	190	63	248	25	22	36	87.6	85.7	34.1	M22	UCFL217	FL217
	370	220	74	300	38	32	44	100	96	40	M33	UCFL317	FL317
90	320	205	68	265	25	23	40	96.3	96	39.7	M22	UCFL218	FL218
	385	235	76	315	38	36	44	100	96	40	M33	UCFL318	FL318
95	405	250	94	330	41	40	59	121	103	41	M36	UCFL319	FL319
100	440	270	94	360	44	40	59	125	108	42	M39	UCFL320	FL320
105	440	270	94	360	44	40	59	127	112	44	M39	UCFL321	FL321
110	470	300	96	390	44	42	60	131	117	46	M39	UCFL322	FL322
120	520	330	110	430	47	48	65	140	126	51	M42	UCFL324	FL324
130	550	360	115	460	47	50	65	146	135	54	M42	UCFL326	FL326
140	600	400	125	500	51	60	75	161	145	59	M45	UCFL328	FL328

[Remarks] 1) Applicable sizes of grease nipples are shown below.
A-1/4-28UNF..... 201~210, X05~X09, 305~308
A-PT 1/8 211~217, X10~X17, 309~328

Tolerances for housing

Pressed steel cover

Cast iron cover

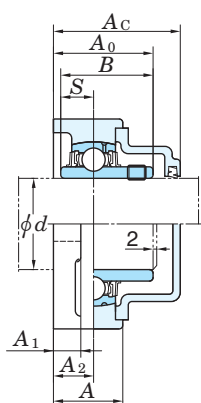
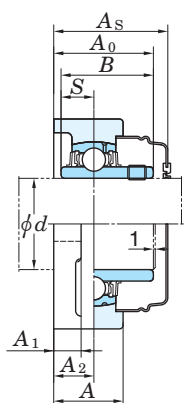

housing No.			ΔN_s
FL204~ FL218	FLX05~ FLX10	FL305~ FL311	± 0.2
		FL312~ FL328	± 0.3

ΔN_s : deviation of bolt hole diameter.

housing No.			ΔA_{2s}	X
FL204~ FL210	FLX05~ FLX10	FL305~ FL310	± 0.5	0.7
FL211~ FL218		FL311~ FL328	± 0.8	1

ΔA_{2s} : deviation of distance from mounting face to centre of spherical bearing seating.

X : positional tolerance of bolt hole.

No.	Applicable bearing			Unit No. with covers				Cover dimensions (mm)		(Refer.) Unit mass (kg)	
	Basic load ratings (kN)		Factor f_0	Pressed steel covers		Cast iron covers		A_s	A_c	Pressed steel covers	Cast iron covers
	C_r	C_{0r}		Open ends	Closed end	Open ends	Closed end				
UC212	52.4	36.2	14.4	UCFL212C	UCFL212D	UCFL212FC	UCFL212FD	73	86	4.2	5.0
UC312	81.9	52.2	13.2	—	—	UCFL312C	UCFL312D	—	95	6.5	7.7
UC213	57.2	40.1	14.4	UCFL213C	UCFL213D	UCFL213FC	UCFL213FD	74	87	5.1	5.9
UC313	92.7	59.9	13.2	—	—	UCFL313C	UCFL313D	—	94	8.5	9.6
UC214	62.2	44.1	14.5	UCFL214C	UCFL214D	UCFL214FC	UCFL214FD	80	93	5.7	6.6
UC314	104	68.2	13.2	—	—	UCFL314C	UCFL314D	—	98	9.7	10.8
UC215	67.4	48.3	14.5	UCFL215C	UCFL215D	UCFL215FC	UCFL215FD	83	96	6.4	7.4
UC315	113	77.2	13.2	—	—	UCFL315C	UCFL315D	—	106	11.3	12.6
UC216	72.7	53.0	14.6	UCFL216C	UCFL216D	UCFL216FC	UCFL216FD	88	103	7.8	9.0
UC316	123	86.7	13.3	—	—	UCFL316C	UCFL316D	—	107	14.4	15.8
UC217	84.0	61.9	14.5	UCFL217C	UCFL217D	UCFL217FC	UCFL217FD	92	107	9.8	11.2
UC317	133	96.8	13.3	—	—	UCFL317C	UCFL317D	—	117	16.0	17.6
UC218	96.1	71.5	14.5	UCFL218C	UCFL218D	UCFL218FC	UCFL218FD	101	116	12.3	13.8
UC318	143	107	13.3	—	—	UCFL318C	UCFL318D	—	119	19.0	20.9
UC319	153	119	13.3	—	—	UCFL319C	UCFL319D	—	140	24.6	26.8
UC320	173	141	13.2	—	—	UCFL320C	UCFL320D	—	146	29.4	32.2
UC321	184	153	13.2	—	—	UCFL321C	UCFL321D	—	148	34.4	37.4
UC322	205	180	13.2	—	—	UCFL322C	UCFL322D	—	154	36.2	39.6
UC324	207	185	13.5	—	—	UCFL324C	UCFL324D	—	163	51.6	56.4
UC326	229	214	13.6	—	—	UCFL326C	UCFL326D	—	172	61.6	67.7
UC328	253	246	13.6	—	—	UCFL328C	UCFL328D	—	186	68.4	76.1

2) Bearings with triple-lip seals are indicated by L3 after the bearing and unit number. (UCFS307JL3, UC307L3)

3) For more detailed information, refer to ball bearing for unit specification tables.

Ball bearing units

light duty rhombic-flanged type

BLF (with set screws)

d 12 ~ 35 mm

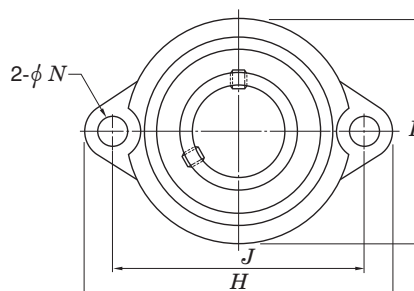
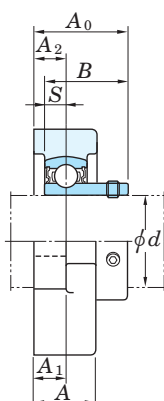

Shaft dia. (mm) d	Dimensions (mm)										Bolt size	Unit No.	Housing No.
	H	L	A	J ± 0.7	N ± 0.2	A_1	A_2 ± 0.5	A_0	B	S			
12	81	52	18	63.5	8	9.5	9.5	25.5	22	6	M6	BLF201	LF203
15	81	52	18	63.5	8	9.5	9.5	25.5	22	6	M6	BLF202	LF203
17	81	52	18	63.5	8	9.5	9.5	25.5	22	6	M6	BLF203	LF203
20	90	60	20	71.5	10	11	11	29	25	7	M8	BLF204	LF204
25	95	64	20	76	10	11	11	30.5	27	7.5	M8	BLF205	LF205
30	113	76	22.5	90.5	12	12	12	34	30	8	M10	BLF206	LF206
35	122	89	24	100	12	13	13	36.5	32	8.5	M10	BLF207	LF207

[Remarks] 1) The radial loading on housing should not exceed 50% of the basic load rating (C_r).
2) For more detailed information, refer to ball bearing for unit specification tables.

No.	Applicable bearing Basic load ratings (kN)		Factor f_0	(Refer.) Unit mass (kg)
	C_r	C_{0r}		
SB201	9.55	4.80	13.2	0.25
SB202	9.55	4.80	13.2	0.25
SB203	9.55	4.80	13.2	0.25
SB204	12.8	6.65	13.2	0.33
SB205	14.0	7.85	13.9	0.38
SB206	19.5	11.3	13.9	0.57
SB207	25.7	15.4	13.9	0.77

Ball bearing units

“compact” series rhombic-flanged type

UFL (with set screws)

d 8 ~ 30 mm

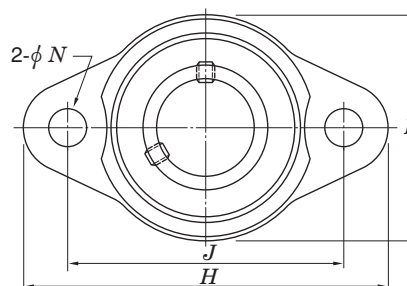
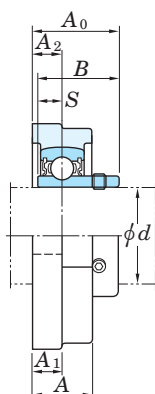

Shaft dia. (mm) d	Dimensions (mm)										Bolt size	Unit No.	Housing No.
	H	L	A	J	N ± 0.2	A_1	A_2 ± 0.5	A_0	B	S			
8	48	27	8.5	37	4.8	4	4	12.5	12	3.5	M4	UFL08	FL08
10	60	36	12	45	7	6	6	16	15	5	M6	UFL000	FL000
12	63	38	12	48	7	6	6	16	15	5	M6	UFL001	FL001
15	67	42	13	53	7	6.5	6.5	17.5	16.5	5.5	M6	UFL002	FL002
17	71	46	14	56	7	7	7	18.5	17.5	6	M6	UFL003	FL003
20	90	55	16	71	10	8	8	22	21	7	M8	UFL004	FL004
25	95	60	16	75	10	8	8	23	22	7	M8	UFL005	FL005
30	112	70	18	85	13	9	9	26	24.5	7.5	M10	UFL006	FL006

[Remarks] 1) Housing is made from special light alloy.
2) For more detailed information, refer to ball bearing for unit specification tables.

Tolerance for housing

unit : mm

housing No.	X
FL000-FL006	0.6

X : positional tolerance of bolt hole.

Open ends type

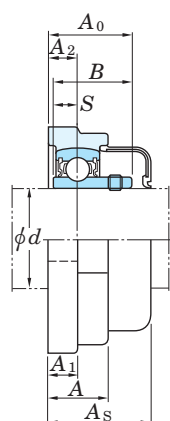

Closed end type

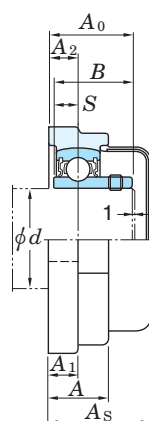

No.	Applicable bearing Basic load ratings (kN)		Factor f_0	Unit No. with covers		Cover dimension (mm) A_s	(Refer.) Unit mass (kg)
	C_r	C_{0r}		Open ends	Closed end		
SU08	3.27	1.37	12.4	—	—	—	0.030
SU000	4.55	1.95	12.3	UFL000C	UFL000D	20.5	0.050
SU001	5.10	2.40	13.2	UFL001C	UFL001D	20.5	0.065
SU002	5.60	2.85	13.9	UFL002C	UFL002D	22	0.085
SU003	6.00	3.25	14.4	UFL003C	UFL003D	23.5	0.11
SU004	9.40	5.05	13.9	UFL004C	UFL004D	27	0.18
SU005	10.1	5.85	14.5	UFL005C	UFL005D	28	0.23
SU006	13.2	8.25	14.7	UFL006C	UFL006D	31	0.31

Ball bearing units

stainless-series rhombic-flanged type

UCSFL-H1S6 (with set screws)

d 12 ~ 50 mm

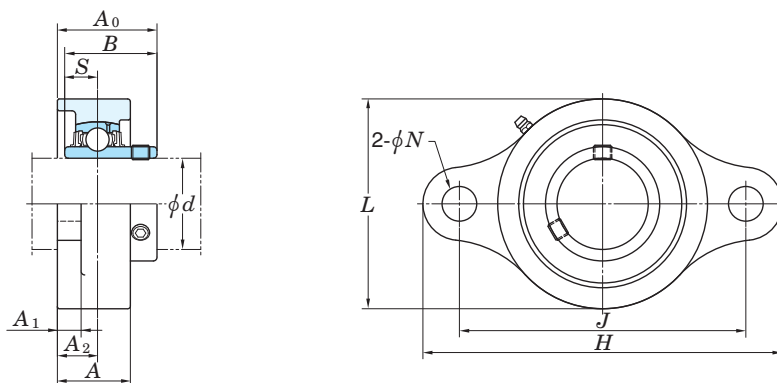

Shaft dia. (mm) d	Dimensions (mm)										Bolt size	Unit No.	Housing No.
	H	L	A	J	N ± 0.2	A_1	A_2 ± 0.5	A_0	B	S			
12	98	54	24	76.5	12	10	14	29.9	27.4	11.5	M10	UCSFL201XH1S6	SFL203H1
15	98	54	24	76.5	12	10	14	29.9	27.4	11.5	M10	UCSFL202XH1S6	SFL203H1
17	98	54	24	76.5	12	10	14	29.9	27.4	11.5	M10	UCSFL203XH1S6	SFL203H1
20	113	60	26	90	12	10	15	33.3	31	12.7	M10	UCSFL204H1S6	SFL204H1
25	130	68	27.5	99	16	10	16	35.8	34.1	14.3	M14	UCSFL205H1S6	SFL205H1
30	148	80	31	117	16	10	18	40.2	38.1	15.9	M14	UCSFL206H1S6	SFL206H1
35	161	90	34	130	16	11	19	44.4	42.9	17.5	M14	UCSFL207H1S6	SFL207H1
40	175	100	36	144	16	12	21	51.2	49.2	19	M14	UCSFL208H1S6	SFL208H1
45	188	108	38	148	19	13	22	52.2	49.2	19	M16	UCSFL209H1S6	SFL209H1
50	197	115	40	157	19	13	22	54.6	51.6	19	M16	UCSFL210H1S6	SFL210H1

[Remarks] 1) Applicable size of grease nipples is A-1/4-28UNF.

Tolerance for housing

Pressed stainless steel covers

unit : mm

housing No.	X
SFL203 H1~210 H1	0.7

X : positional tolerance of bolt hole.

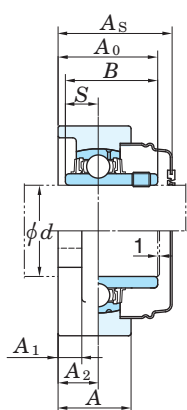

No.	Applicable bearing Basic load ratings (kN)		Factor f_0	Unit No. with covers		Cover dimension (mm) A_s	(Refer.) Unit mass (kg) Pressed steel covers
	C_r	C_{0r}		Open ends	Closed end		
UC201XS6	8.15	3.85	13.2	—	—	—	0.31
UC202XS6	8.15	3.85	13.2	—	—	—	0.31
UC203XS6	8.15	3.85	13.2	—	—	—	0.31
UC204S6	10.9	5.35	13.2	UCSFL204H1CS6	UCSFL204H1DS6	38	0.43
UC205S6	11.9	6.30	13.9	UCSFL205H1CS6	UCSFL205H1DS6	40	0.60
UC206S6	16.5	9.05	13.9	UCSFL206H1CS6	UCSFL206H1DS6	45	0.86
UC207S6	21.8	12.3	13.9	UCSFL207H1CS6	UCSFL207H1DS6	49	1.1
UC208S6	24.8	14.3	14.0	UCSFL208H1CS6	UCSFL208H1DS6	56	1.5
UC209S6	27.8	16.2	14.0	UCSFL209H1CS6	UCSFL209H1DS6	57	1.8
UC210S6	29.8	18.6	14.4	UCSFL210H1CS6	UCSFL210H1DS6	59	2.1

2) For more detailed information, refer to ball bearing for unit specification tables.

Ball bearing units

round-flanged type with spigot joint

UCFC (with set screws)

d 12 ~ 65 mm

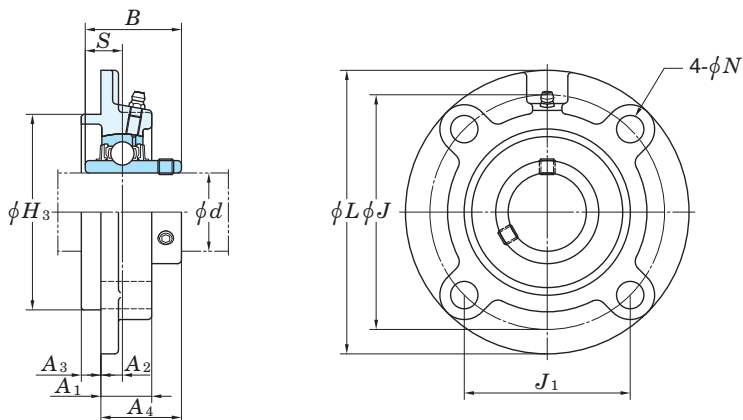

Shaft dia. (mm) d	Dimensions (mm)											Bolt size	Unit No.	Housing No.	
	L	H_3	J	J_1	$N_{\pm 0.2}$	A_1	A_2	A_3	A_4	B	S				
12	100	62	78	55.1	12	20.5	10	5	28.3	31	12.7	M10	UCFC201	FC204	
15	100	62	78	55.1	12	20.5	10	5	28.3	31	12.7	M10	UCFC202	FC204	
17	100	62	78	55.1	12	20.5	10	5	28.3	31	12.7	M10	UCFC203	FC204	
20	100	62	78	55.1	12	20.5	10	5	28.3	31	12.7	M10	UCFC204	FC204	
25	115	70	90	63.6	12	21	10	6	29.8	34.1	14.3	M10	UCFC205	FC205	
	111	76	92	65	9.5	24	10	6	32.2	38.1	15.9	M8	UCFCX05	FCX05	
30	125	80	100	70.7	12	23	10	8	32.2	38.1	15.9	M10	UCFC206	FC206	
	127	85	105	74.2	12	22.5	8	9.5	33.4	42.9	17.5	M10	UCFCX06	FCX06	
35	135	90	110	77.8	14	26	11	8	36.4	42.9	17.5	M12	UCFC207	FC207	
	133	92	111	78.5	12	26	9	11	39.2	49.2	19	M10	UCFCX07	FCX07	
40	145	100	120	84.8	14	26	11	10	41.2	49.2	19	M12	UCFC208	FC208	
	133	92	111	78.5	12	26	9	11	39.2	49.2	19	M10	UCFCX08	FCX08	
45	160	105	132	93.3	16	26	10	12	40.2	49.2	19	M14	UCFC209	FC209	
	155	108	130	91.9	14	25	8	12	40.6	51.6	19	M12	UCFCX09	FCX09	
50	165	110	138	97.6	16	28	10	12	42.6	51.6	19	M14	UCFC210	FC210	
	162	118	136	96.2	14	25	7	16	40.4	55.6	22.2	M12	UCFCX10	FCX10	
55	185	125	150	106.1	19	31	13	12	46.4	55.6	22.2	M16	UCFC211	FC211	
	180	127	152	107.5	16	26	4	22	43.7	65.1	25.4	M14	UCFCX11	FCX11	
60	195	135	160	113.1	19	36	17	12	56.7	65.1	25.4	M16	UCFC212	FC212	
	194	140	165	116.7	16	33	11	20	50.7	65.1	25.4	M14	UCFCX12	FCX12	
65	205	145	170	120.2	19	36	16	14	55.7	65.1	25.4	M16	UCFC213	FC213	
	194	140	165	116.7	16	33	11	20	55.4	74.6	30.2	M14	UCFCX13	FCX13	

[Remarks] 1) Applicable sizes of grease nipples are shown below.
 A-1/4-28UNF 201~210, X05~X09
 A-PT 1/8 211~218, X10~X20

Pressed steel cover

Cast iron cover

Tolerances for housing

unit : mm

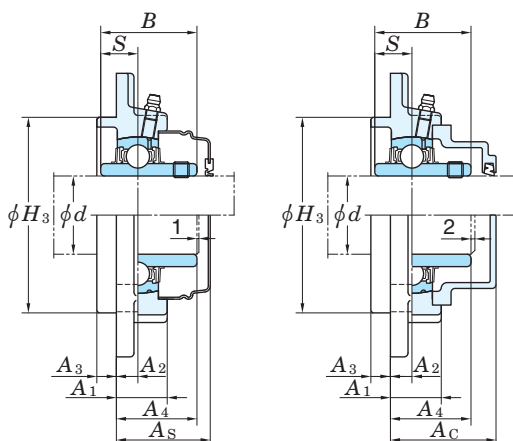

housing No.		ΔH_{3s}	ΔA_{2s}	X	Y
FC204~ FC206	FCX05	0 -0.046	±0.5	0.7	0.2
FC207~ FC210	FCX06~ FCX10	0 -0.054			
FC211~ FC217	FCX11~ FCX15	0 -0.063	±0.8	1	0.3
FC218	FCX16~ FCX18	0 -0.072			
	FCX20				0.4

ΔH_{3s} : deviation of spigot joint outside diameter.

ΔA_{2s} : deviation of distance from mounting face to centre of spherical bearing seating.

X : positional tolerance of bolt hole.

Y : circumferential runout tolerance of spigot joint in respect to axial line of spherical bearing seating.

No.	Applicable bearing		Factor f_0	Unit No. with covers				Cover dimensions (mm)		(Refer.) Unit Mass (kg)	
	Basic load ratings (kN) C_r	C_{Or}		Pressed steel covers Open ends	Closed end	Cast iron covers Open ends	Closed end	A_s	A_c	Pressed steel covers	Cast iron covers
UC201	12.8	6.65	13.2	UCFC201C	UCFC201D	—	—	32	—	0.78	—
UC202	12.8	6.65	13.2	UCFC202C	UCFC202D	—	—	32	—	0.76	—
UC203	12.8	6.65	13.2	UCFC203C	UCFC203D	—	—	32	—	0.75	—
UC204	12.8	6.65	13.2	UCFC204C	UCFC204D	UCFC204FC	UCFC204FD	32	38.5	0.73	0.84
UC205	14.0	7.85	13.9	UCFC205C	UCFC205D	UCFC205FC	UCFC205FD	34	42	0.95	1.1
UCX05	19.5	11.3	13.9	UCFCX05C	UCFCX05D	—	—	36	—	1.2	—
UC206	19.5	11.3	13.9	UCFC206C	UCFC206D	UCFC206FC	UCFC206FD	36	45	1.3	1.6
UCX06	25.7	15.4	13.9	UCFCX06C	UCFCX06D	—	—	38	—	1.5	—
UC207	25.7	15.4	13.9	UCFC207C	UCFC207D	UCFC207FC	UCFC207FD	41	50	1.7	2.1
UCX07	29.1	17.8	14.0	UCFCX07C	UCFCX07D	—	—	43	—	1.9	—
UC208	29.1	17.8	14.0	UCFC208C	UCFC208D	UCFC208FC	UCFC208FD	45	54	2.0	2.4
UCX08	32.7	20.3	14.0	UCFCX08C	UCFCX08D	—	—	43	—	2.0	—
UC209	32.7	20.3	14.0	UCFC209C	UCFC209D	UCFC209FC	UCFC209FD	44	54	2.6	3.0
UCX09	35.1	23.3	14.4	UCFCX09C	UCFCX09D	—	—	45	—	2.6	—
UC210	35.1	23.3	14.4	UCFC210C	UCFC210D	UCFC210FC	UCFC210FD	47	58.5	2.9	3.4
UCX10	43.4	29.4	14.4	UCFCX10C	UCFCX10D	—	—	45	—	3.2	—
UC211	43.4	29.4	14.4	UCFC211C	UCFC211D	UCFC211FC	UCFC211FD	51	62.5	4.2	4.8
UCX11	52.4	36.2	14.4	UCFCX11C	UCFCX11D	—	—	48	—	4.3	—
UC212	52.4	36.2	14.4	UCFC212C	UCFC212D	UCFC212FC	UCFC212FD	61	74	5.0	5.8
UCX12	57.2	40.1	14.4	UCFCX12C	UCFCX12D	—	—	55	—	5.3	—
UC213	57.2	40.1	14.4	UCFC213C	UCFC213D	UCFC213FC	UCFC213FD	60	73	5.6	6.4
UCX13	62.2	44.1	14.5	UCFCX13C	UCFCX13D	—	—	60	—	5.7	—

2) For bearings with double- or triple-lip seals, unit and bearing number are suffixed by L2 or L3.
(UCFC206JL3, UC206L3)

3) For more detailed information, refer to ball bearing for unit specification tables.

Ball bearing units

round-flanged type with spigot joint

UCFC (with set screws)

d 70 ~ 100 mm

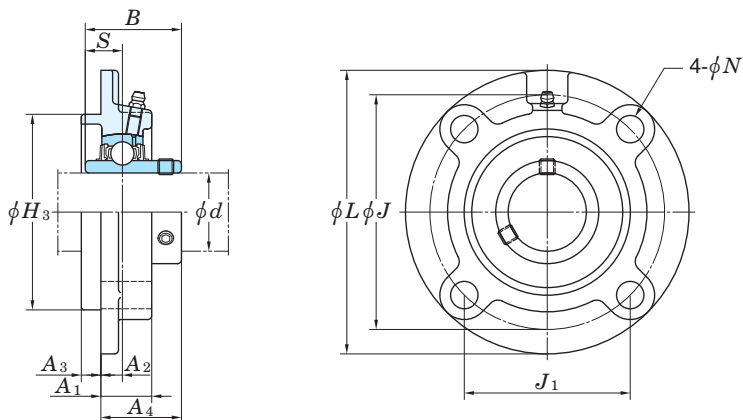

Shaft dia. (mm) d	Dimensions (mm)											Bolt size	Unit No.	Housing No.	
	L	H_3	J	J_1	$N_{\pm 0.2}$	A_1	A_2	A_3	A_4	B	S				
70	215	150	177	125.1	19	40	17	14	61.4	74.6	30.2	M16	UCFC214 UCFCX14	FC214 FCX14	
	222	164	190	134.3	19	36	14	20	58.5	77.8	33.3	M16			
75	220	160	184	130.1	19	40	18	16	62.5	77.8	33.3	M16	UCFC215 UCFCX15	FC215 FCX15	
	222	164	190	134.3	19	35	12	22	61.3	82.6	33.3	M16			
80	240	170	200	141.4	23	42	18	16	67.3	82.6	33.3	M20	UCFC216 UCFCX16	FC216 FCX16	
	260	186	219	154.8	23	36	10	25	61.6	85.7	34.1	M20			
85	250	180	208	147.1	23	45	18	18	69.6	85.7	34.1	M20	UCFC217 UCFCX17	FC217 FCX17	
	260	186	219	154.8	23	36	10	25	66.3	96	39.7	M20			
90	265	190	220	155.5	23	50	22	18	78.3	96	39.7	M20	UCFC218 UCFCX18	FC218 FCX18	
	260	186	219	154.8	23	43	12	28	73.1	104	42.9	M20			
100	276	206	238	168.3	23	66	22	28	90.3	117.5	49.2	M20	UCFCX20	FCX20	

[Remarks] 1) Applicable sizes of grease nipples are shown below.
 A-1/4-28UNF..... 201~210, X05~X09
 A-PT 1/8 211~218, X10~X20

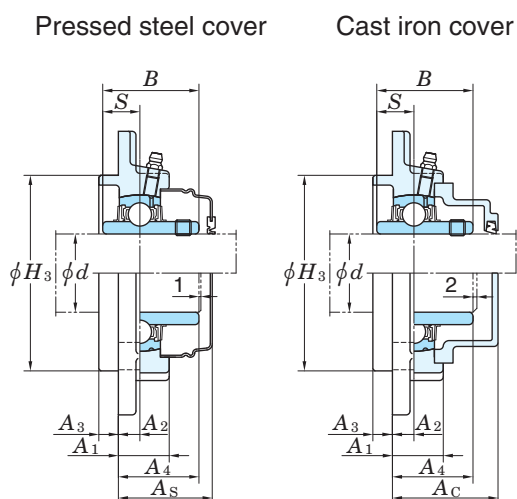

Tolerances for housing

unit : mm

housing No.		ΔH_{3s}	ΔA_{2s}	X	Y
FC204~ FC206	FCX05	0 -0.046	±0.5	0.7	0.2
FC207~ FC210	FCX06~ FCX10	0 -0.054			
FC211~ FC217	FCX11~ FCX15	0 -0.063	±0.8	1	0.3
FC218	FCX16~ FCX18	0 -0.072			
	FCX20				0.4

ΔH_{3s} : deviation of spigot joint outside diameter.

ΔA_{2s} : deviation of distance from mounting face to centre of spherical bearing seating.

X : positional tolerance of bolt hole.

Y : circumferential runout tolerance of spigot joint in respect to axial line of spherical bearing seating.

No.	Applicable bearing			Unit No. with covers				Cover dimensions (mm)		(Refer.) Unit Mass (kg)	
	Basic load ratings (kN)		Factor f_0	Pressed steel covers		Cast iron covers		A_s	A_c	Pressed steel covers	Cast iron covers
	C_r	C_{0r}		Open ends	Closed end	Open ends	Closed end				
UC214 UCX14	62.2 67.4	44.1 48.3	14.5 14.5	UCFC214C UCFCX14C	UCFC214D UCFCX14D	UCFC214FC —	UCFC214FD —	66 63	79 —	6.8 7.3	7.7 —
UC215 UCX15	67.4 72.7	48.3 53.0	14.5 14.6	UCFC215C UCFCX15C	UCFC215D UCFCX15D	UCFC215FC —	UCFC215FD —	67 66	80 —	7.2 8.0	8.2 —
UC216 UCX16	72.7 84.0	53.0 61.9	14.6 14.5	UCFC216C UCFCX16C	UCFC216D UCFCX16D	UCFC216FC —	UCFC216FD —	72 66	87 —	8.7 11.3	9.9 —
UC217 UCX17	84.0 96.1	61.9 71.5	14.5 14.5	UCFC217C UCFCX17C	UCFC217D UCFCX17D	UCFC217FC —	UCFC217FD —	74 71	89 —	10.3 12.9	11.7 —
UC218 UCX18	96.1 109	71.5 81.9	14.5 14.4	UCFC218C —	UCFC218D —	UCFC218FC UCFCX18C	UCFC218FD UCFCX18D	83 —	98 92	13.3 13.5	14.8 15.4
UCX20	133	105	14.4	—	—	UCFCX20C	UCFCX20D	—	116	18.2	20.7

2) For bearings with double- or triple-lip seals, unit and bearing number are suffixed by L2 or L3. (UCFC206JL3, UC206L3)

3) For more detailed information, refer to ball bearing for unit specification tables.

Ball bearing units

pressed steel round-flanged type

SBPF (with set screws)

d 12 ~ 35 mm

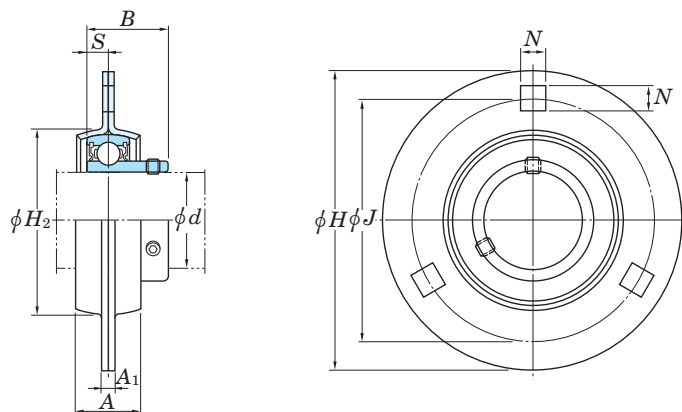

Shaft dia. (mm) d	Dimensions (mm)								Bolt size	Unit No.	Housing No.
	H	A	A_1	J ± 0.4	N ± 0.25	H_2 ¹⁾	B	S			
12	81	14	4	63.5	7.1	49	22	6	M6	SBPF201	PF203
15	81	14	4	63.5	7.1	49	22	6	M6	SBPF202	PF203
17	81	14	4	63.5	7.1	49	22	6	M6	SBPF203	PF203
20	90	16	4	71.5	9	55	25	7	M8	SBPF204	PF204
25	95	18	4	76	9	60	27	7.5	M8	SBPF205	PF205
30	113	19	5.2	90.5	11	71	30	8	M10	SBPF206	PF206
35	122	22	5.2	100	11	81	32	8.5	M10	SBPF207	PF207

[Note] 1) H_2 shows minimum dimension of mounting hole.

[Remark] For more detailed information, refer to ball bearing for unit specification tables.

No.	Applicable bearing Basic load ratings (kN)		Factor f_0	(Refer.) Unit mass (kg)
	C_r	C_{0r}		
SB201	9.55	4.80	13.2	0.27
SB202	9.55	4.80	13.2	0.27
SB203	9.55	4.80	13.2	0.27
SB204	12.8	6.65	13.2	0.33
SB205	14.0	7.85	13.9	0.38
SB206	19.5	11.3	13.9	0.62
SB207	25.7	15.4	13.9	0.82

Ball bearing units

pressed steel rhombic-flanged type

SBPFL (with set screws)

d 12 ~ 35 mm

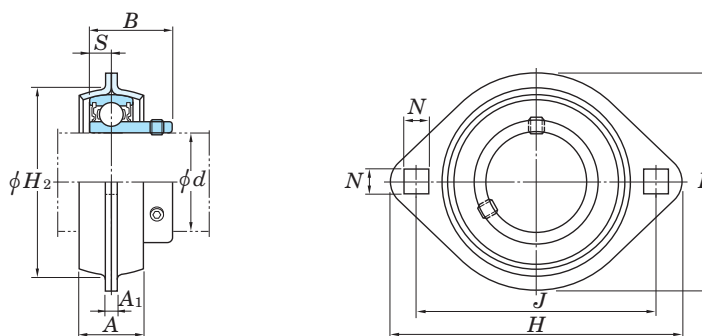

Shaft dia. (mm) d	Dimensions (mm)									Bolt size	Unit No.	Housing No.
	H	L	A	A_1	J ± 0.4	N ± 0.25	H_2 ¹⁾	B	S			
12	81	59	14	4	63.5	7.1	49	22	6	M6	SBPFL201	PFL203
15	81	59	14	4	63.5	7.1	49	22	6	M6	SBPFL202	PFL203
17	81	59	14	4	63.5	7.1	49	22	6	M6	SBPFL203	PFL203
20	90	67	16	4	71.5	9	55	25	7	M8	SBPFL204	PFL204
25	95	71	18	4	76	9	60	27	7.5	M8	SBPFL205	PFL205
30	113	84	19	5.2	90.5	11	71	30	8	M10	SBPFL206	PFL206
35	122	94	22	5.2	100	11	81	32	8.5	M10	SBPFL207	PFL207

[Note] 1) H_2 shows minimum dimension of mounting hole.

[Remark] For more detailed information, refer to ball bearing for unit specification tables.

	No.	Applicable bearing Basic load ratings (kN)		Factor f_0	(Refer.) Unit mass (kg)
		C_r	C_{0r}		
	SB201	9.55	4.80	13.2	0.19
	SB202	9.55	4.80	13.2	0.19
	SB203	9.55	4.80	13.2	0.19
	SB204	12.8	6.65	13.2	0.24
	SB205	14.0	7.85	13.9	0.28
	SB206	19.5	11.3	13.9	0.38
	SB207	25.7	15.4	13.9	0.66

Ball bearing units take-up type UCT (with set screws)

d 12 ~ (55) mm

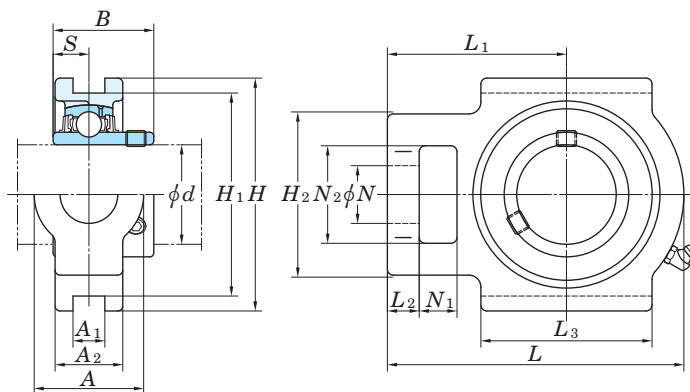

Shaft dia. (mm) d	Dimensions (mm)															Unit No.	Housing No.
	A	A ₁	A ₂	H	H ₁	H ₂	L	L ₁	L ₂	L ₃	N	N ₁	N ₂	B	S		
12	32	12	21	89	76	51	94	61	10	51	19	16	32	31	12.7	UCT201	T204
15	32	12	21	89	76	51	94	61	10	51	19	16	32	31	12.7	UCT202	T204
17	32	12	21	89	76	51	94	61	10	51	19	16	32	31	12.7	UCT203	T204
20	32	12	21	89	76	51	94	61	10	51	19	16	32	31	12.7	UCT204	T204
25	32	12	24	89	76	51	97	62	10	51	19	16	32	34.1	14.3	UCT205	T205
	37	12	28	102	89	56	113	70	10	57	22	16	37	38.1	15.9	UCTX05	TX05
	36	12	26	89	80	62	122	76	12	65	26	16	36	38	15	UCT305	T305
30	37	12	28	102	89	56	113	70	10	57	22	16	37	38.1	15.9	UCT206	T206
	37	12	30	102	89	64	129	78	13	64	22	16	37	42.9	17.5	UCTX06	TX06
	41	16	28	100	90	70	137	85	14	74	28	18	41	43	17	UCT306	T306
35	37	12	30	102	89	64	129	78	13	64	22	16	37	42.9	17.5	UCT207	T207
	49	16	36	114	102	83	144	88	15	83	29	19	49	49.2	19	UCTX07	TX07
	45	16	32	111	100	75	150	94	15	80	30	20	45	48	19	UCT307	T307
40	49	16	33	114	102	83	144	88	16	83	29	19	49	49.2	19	UCT208	T208
	49	16	36	117	102	83	144	87	15	83	29	19	49	49.2	19	UCTX08	TX08
	50	18	34	124	112	83	162	100	17	89	32	22	50	52	19	UCT308	T308
45	49	16	35	117	102	83	144	87	16	83	29	19	49	49.2	19	UCT209	T209
	49	16	38	117	102	83	149	90	16	86	29	19	49	51.6	19	UCTX09	TX09
	55	18	38	138	125	90	178	110	18	97	34	24	55	57	22	UCT309	T309
50	49	16	37	117	102	83	149	90	16	86	29	19	49	51.6	19	UCT210	T210
	64	22	42	146	130	102	171	106	19	95	35	25	64	55.6	22.2	UCTX10	TX10
	61	20	40	151	140	98	191	117	20	106	37	27	61	61	22	UCT310	T310
55	64	22	38	146	130	102	171	106	19	95	35	25	64	55.6	22.2	UCT211	T211

[Remarks] 1) Applicable sizes of grease nipples are shown below.
 B-1/4-28UNF..... 201~210, X05~X09, 305~308
 B-PT 1/8 211~217, X10~X17, 309~328

Tolerances for housing

unit : mm

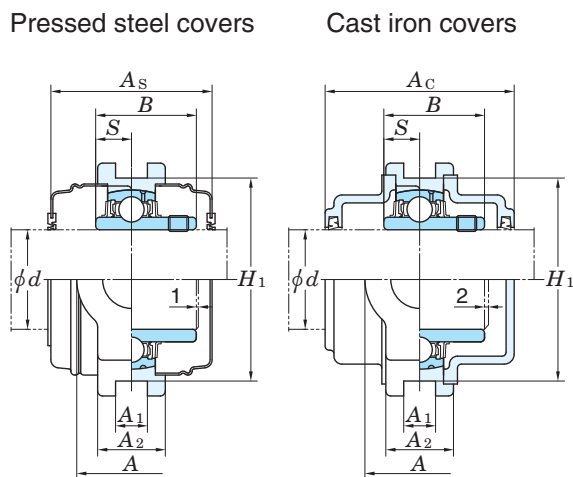

housing No.			ΔA_{1s}	ΔH_{1s}	X
T204- T210	TX05~ TX10	T305~ T310	+0.2 0	0 -0.5	0.5
T211~ T217	TX11~ TX17	T311~ T318	+0.3 0	0 -0.8	0.6
		T319~ T322			0.7
		T324~ T328			0.8

ΔA_{1s} : deviation of nominal raceway groove width.
 ΔH_{1s} : deviation of distance between both groove bottoms.

X : symmetry tolerance of both groove-side face.

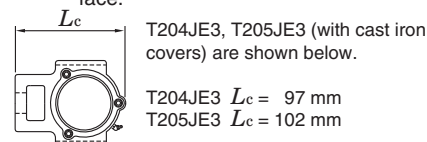

No.	Applicable bearing			Unit No. with covers				Cover dimensions (mm)		(Refer.) Unit mass (kg)	
	Basic load ratings (kN)		Factor f_0	Pressed steel covers		Cast iron covers		A_s	A_c	Pressed steel covers	Cast iron covers
	C_r	C_{0r}		Open ends	Closed end	Open ends	Closed end				
UC201	12.8	6.65	13.2	UCT201C	UCT201CD	—	—	44	—	0.81	—
UC202	12.8	6.65	13.2	UCT202C	UCT202CD	—	—	44	—	0.79	—
UC203	12.8	6.65	13.2	UCT203C	UCT203CD	—	—	44	—	0.78	—
UC204	12.8	6.65	13.2	UCT204C	UCT204CD	UCT204FC	UCT204FCD	44	62	0.76	1.1
UC205	14.0	7.85	13.9	UCT205C	UCT205CD	UCT205FC	UCT205FCD	48	66	0.84	1.2
UCX05	19.5	11.3	13.9	UCTX05C	UCTX05CD	—	—	52	—	1.4	—
UC305	21.2	10.9	12.6	—	—	UCT305C	UCT305CD	—	76	1.4	2.0
UC206	19.5	11.3	13.9	UCT206C	UCT206CD	UCT206FC	UCT206FCD	52	70	1.3	1.8
UCX06	25.7	15.4	13.9	UCTX06C	UCTX06CD	—	—	59	—	1.7	—
UC306	26.7	15.0	13.3	—	—	UCT306C	UCT306CD	—	82	1.8	2.4
UC207	25.7	15.4	13.9	UCT207C	UCT207CD	UCT207FC	UCT207FCD	59	78	1.6	2.3
UCX07	29.1	17.8	14.0	UCTX07C	UCTX07CD	—	—	68	—	2.7	—
UC307	33.4	19.3	13.2	—	—	UCT307C	UCT307CD	—	88	2.3	3.1
UC208	29.1	17.8	14.0	UCT208C	UCT208CD	UCT208FC	UCT208FCD	68	86	2.5	3.3
UCX08	32.7	20.3	14.0	UCTX08C	UCTX08CD	—	—	68	—	2.6	—
UC308	40.7	24.0	13.2	—	—	UCT308C	UCT308CD	—	96	3.0	4.0
UC209	32.7	20.3	14.0	UCT209C	UCT209CD	UCT209FC	UCT209FCD	68	88	2.4	3.2
UCX09	35.1	23.3	14.4	UCTX09C	UCTX09CD	—	—	73	—	2.9	—
UC309	48.9	29.5	13.3	—	—	UCT309C	UCT309CD	—	102	4.1	5.4
UC210	35.1	23.3	14.4	UCT210C	UCT210CD	UCT210FC	UCT210FCD	73	97	2.6	3.6
UCX10	43.4	29.4	14.4	UCTX10C	UCTX10CD	—	—	75	—	4.4	—
UC310	62.0	38.3	13.2	—	—	UCT310C	UCT310CD	—	110	4.9	6.5
UC211	43.4	29.4	14.4	UCT211C	UCT211CD	UCT211FC	UCT211FCD	75	99	4.0	5.2

2) For bearings with double- or triple-lip seals, unit and bearing number are suffixed by L2 or L3.
 (UCT206JL3, UC206L3)

3) For more detailed information, refer to ball bearing for unit specification tables.

Ball bearing units take-up type UCT (with set screws)

d (55) ~ 100 mm

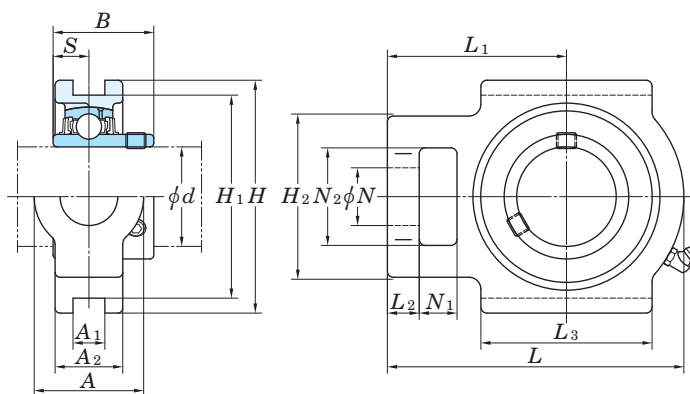

Shaft dia. (mm) d	Dimensions (mm)															Unit No.	Housing No.
	A	A ₁	A ₂	H	H ₁	H ₂	L	L ₁	L ₂	L ₃	N	N ₁	N ₂	B	S		
55	64	22	44	146	130	102	194	119	19	102	35	32	64	65.1	25.4	UCTX11 UCT311	TX11 T311
	66	22	44	163	150	105	207	127	21	115	39	29	66	66	25		
60	64	22	42	146	130	102	194	119	19	102	35	32	64	65.1	25.4	UCT212 UCTX12 UCT312	T212 TX12 T312
	70	26	48	167	151	111	224	137	21	121	41	32	70	65.1	25.4		
	71	22	46	178	160	113	220	135	23	123	41	31	71	71	26		
65	70	26	44	167	151	111	224	137	21	121	41	32	70	65.1	25.4	UCT213 UCTX13 UCT313	T213 TX13 T313
	70	26	48	167	151	111	224	137	21	121	41	32	70	74.6	30.2		
	80	26	50	190	170	116	238	146	25	134	43	32	70	75	30		
70	70	26	46	167	151	111	224	137	21	121	41	32	70	74.6	30.2	UCT214 UCTX14 UCT314	T214 TX14 T314
	70	26	48	167	151	111	232	140	21	121	41	32	70	77.8	33.3		
	90	26	52	202	180	130	252	155	25	140	46	36	85	78	33		
75	70	26	48	167	151	111	232	140	21	121	41	32	70	77.8	33.3	UCT215 UCTX15 UCT315	T215 TX15 T315
	70	28	48	184	165	111	235	140	21	121	41	32	70	82.6	33.3		
	90	26	55	216	192	132	262	160	25	150	46	36	85	82	32		
80	70	26	51	184	165	111	235	140	21	121	41	32	70	82.6	33.3	UCT216 UCTX16 UCT316	T216 TX16 T316
	73	28	54	198	173	124	260	162	28	157	48	38	73	85.7	34.1		
	102	30	60	230	204	150	282	174	28	160	53	42	98	86	34		
85	73	30	54	198	173	124	260	162	29	157	48	38	73	85.7	34.1	UCT217 UCTX17 UCT317	T217 TX17 T317
	73	28	54	198	173	124	260	162	28	157	48	38	73	96	39.7		
	102	32	64	240	214	152	298	183	30	170	53	42	98	96	40		
90	110	32	66	255	228	160	312	192	30	175	57	46	106	96	40	UCT318	T318
95	110	35	72	270	240	165	322	197	31	180	57	46	106	103	41	UCT319	T319
100	120	35	75	290	260	175	345	210	32	200	59	48	115	108	42	UCT320	T320

[Remarks] 1) Applicable sizes of grease nipples are shown below.
 B-1/4-28UNF..... 201~210, X05~X09, 305~308
 B-PT 1/8 211~217, X10~X17, 309~328

Tolerances for housing

unit : mm

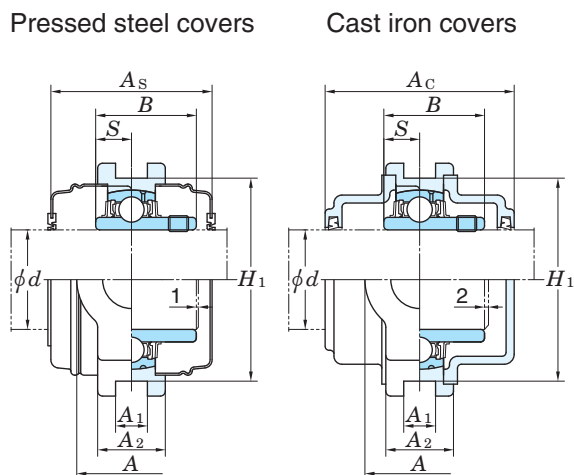

housing No.			ΔA_{1s}	ΔH_{1s}	X
T204~T210	TX05~TX10	T305~T310	+0.2 0	0 -0.5	0.5
T211~T217	TX11~TX17	T311~T318	+0.3 0	0 -0.8	0.6
		T319~T322			0.7
		T324~T328			0.8

ΔA_{1s} : deviation of nominal raceway groove width.
 ΔH_{1s} : deviation of distance between both groove bottoms.

X : symmetry tolerance of both groove-side face.

No.	Applicable bearing			Unit No. with covers				Cover dimensions (mm)		(Refer.) Unit mass (kg)	
	Basic load ratings (kN)		Factor f_0	Pressed steel covers		Cast iron covers		A_s	A_c	Pressed steel covers	Cast iron covers
	C_r	C_{0r}		Open ends	Closed end	Open ends	Closed end				
UCX11	52.4	36.2	14.4	UCTX11C	UCTX11CD	—	—	88	—	5.3	—
UC311	71.6	45.0	13.2	—	—	UCT311C	UCT311CD	—	114	6.1	7.9
UC212	52.4	36.2	14.4	UCT212C	UCT212CD	UCT212FC	UCT212FCD	88	114	4.9	6.4
UCX12	57.2	40.1	14.4	UCTX12C	UCTX12CD	—	—	88	—	7.4	—
UC312	81.9	52.2	13.2	—	—	UCT312C	UCT312CD	—	124	7.6	9.9
UC213	57.2	40.1	14.4	UCT213C	UCT213CD	UCT213FC	UCT213FCD	88	114	6.9	8.6
UCX13	62.2	44.1	14.5	UCTX13C	UCTX13CD	—	—	98	—	7.6	—
UC313	92.7	59.9	13.2	—	—	UCT313C	UCT313CD	—	122	9.3	11.4
UC214	62.2	44.1	14.5	UCT214C	UCT214CD	UCT214FC	UCT214FCD	98	124	7.0	8.9
UCX14	67.4	48.3	14.5	UCTX14C	UCTX14CD	—	—	98	—	7.9	—
UC314	104	68.2	13.2	—	—	UCT314C	UCT314CD	—	124	11.1	13.4
UC215	67.4	48.3	14.5	UCT215C	UCT215CD	UCT215FC	UCT215FCD	98	124	7.3	9.2
UCX15	72.7	53.0	14.6	UCTX15C	UCTX15CD	—	—	108	—	8.7	—
UC315	113	77.2	13.2	—	—	UCT315C	UCT315CD	—	134	13.0	15.5
UC216	72.7	53.0	14.6	UCT216C	UCT216CD	UCT216FC	UCT216FCD	108	138	8.2	10.6
UCX16	84.0	61.9	14.5	UCTX16C	UCTX16CD	—	—	112	—	11.7	—
UC316	123	86.7	13.3	—	—	UCT316C	UCT316CD	—	138	16.2	19.1
UC217	84.0	61.9	14.5	UCT217C	UCT217CD	UCT217FC	UCT217FCD	112	142	11.0	13.7
UCX17	96.1	71.5	14.5	UCTX17C	UCTX17CD	—	—	122	—	11.7	—
UC317	133	96.8	13.3	—	—	UCT317C	UCT317CD	—	146	19.0	22.3
UC318	143	107	13.3	—	—	UCT318C	UCT318CD	—	150	21.6	25.4
UC319	153	119	13.3	—	—	UCT319C	UCT319CD	—	162	24.9	29.2
UC320	173	141	13.2	—	—	UCT320C	UCT320CD	—	174	30.7	36.3

2) For bearings with double- or triple-lip seals, unit and bearing number are suffixed by L2 or L3.
 (UCT206JL3, UC206L3)

3) For more detailed information, refer to ball bearing for unit specification tables.

Ball bearing units take-up type UCT (with set screws)

d 105 ~ 140 mm

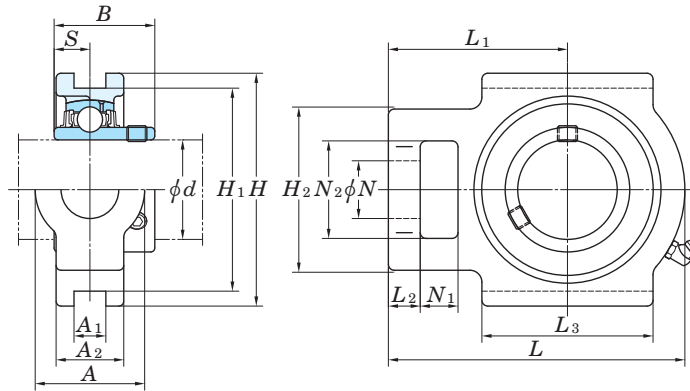

Shaft dia. (mm) d	Dimensions (mm)															Unit No.	Housing No.
	A	A_1	A_2	H	H_1	H_2	L	L_1	L_2	L_3	N	N_1	N_2	B	S		
105	120	35	75	290	260	175	345	210	32	200	59	48	115	112	44	UCT321	T321
110	130	38	80	320	285	185	385	235	38	215	65	52	125	117	46	UCT322	T322
120	140	45	90	355	320	210	432	267	42	230	70	60	140	126	51	UCT324	T324
130	150	50	100	385	350	220	465	285	45	240	75	65	150	135	54	UCT326	T326
140	155	50	100	415	380	230	515	315	50	255	80	70	160	145	59	UCT328	T328

[Remarks] 1) Applicable sizes of grease nipples are shown below.
 B-1/4-28UNF..... 201~210, X05~X09, 305~308
 B-PT 1/8 211~217, X10~X17, 309~328

Tolerances for housing

unit : mm

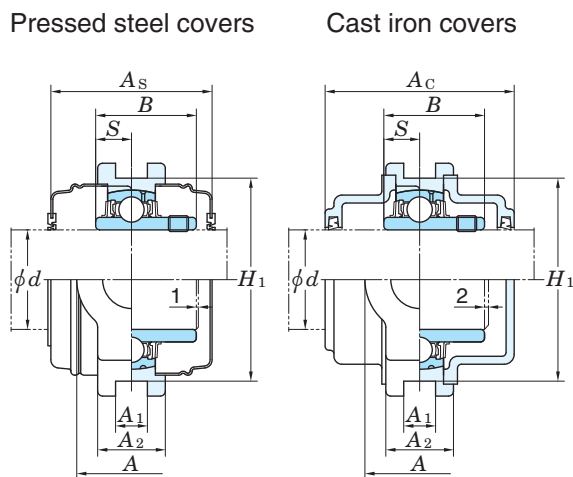

housing No.			ΔA_{1s}	ΔH_{1s}	X
T204~ T210	TX05~ TX10	T305~ T310	+0.2 0	0 -0.5	0.5
T211~ T217	TX11~ TX17	T311~ T318	+0.3 0	0 -0.8	0.6
		T319~ T322			0.7
		T324~ T328			0.8

ΔA_{1s} : deviation of nominal raceway groove width.

ΔH_{1s} : deviation of distance between both groove bottoms.

X : symmetry tolerance of both groove-side face.

No.	Applicable bearing			Unit No. with covers				Cover dimensions (mm)		(Refer.) Unit mass (kg)	
	Basic load ratings (kN)		Factor f_0	Pressed steel covers		Cast iron covers		A_s	A_c	Pressed steel covers	Cast iron covers
	C_r	C_{0r}		Open ends	Closed end	Open ends	Closed end				
UC321	184	153	13.2	—	—	UCT321C	UCT321CD	—	178	36.7	42.7
UC322	205	180	13.2	—	—	UCT322C	UCT322CD	—	188	39.7	46.5
UC324	207	185	13.5	—	—	UCT324C	UCT324CD	—	196	54.4	63.9
UC326	229	214	13.6	—	—	UCT326C	UCT326CD	—	214	69.3	81.4
UC328	253	246	13.6	—	—	UCT328C	UCT328CD	—	222	85.1	101

2) For bearings with double- or triple-lip seals, unit and bearing number are suffixed by L2 or L3. (UCT206JL3, UC206L3)

3) For more detailed information, refer to ball bearing for unit specification tables.

Ball bearing units cartridge type UCC (with set screws)

d 12 ~ 50 mm

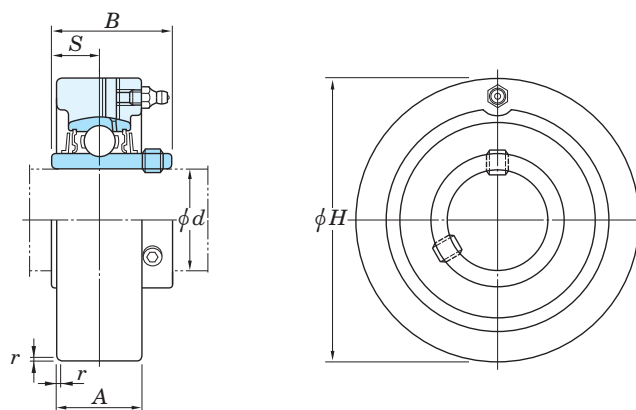

Shaft dia. (mm) d	Dimensions (mm)					Unit No.	Housing No.	No.	Applicable bearing Basic load ratings (kN)		Factor f_0	(Refer.) Unit mass (kg)
	H	A	r	B	S				C_r	C_{0r}		
12	72	20	1.5	31	12.7	UCC201	C204	UC201	12.8	6.65	13.2	0.52
15	72	20	1.5	31	12.7	UCC202	C204	UC202	12.8	6.65	13.2	0.50
17	72	20	1.5	31	12.7	UCC203	C204	UC203	12.8	6.65	13.2	0.49
20	72	20	1.5	31	12.7	UCC204	C204	UC204	12.8	6.65	13.2	0.47
25	80	22	1.5	34.1	14.3	UCC205	C205	UC205	14.0	7.85	13.9	0.64
	90	27	1.5	38.1	15.9	UCCX05	CX05	UCX05	19.5	11.3	13.9	1.0
	90	26	2	38	15	UCC305	C305	UC305	21.2	10.9	12.6	1.5
30	85	27	1.5	38.1	15.9	UCC206	C206	UC206	19.5	11.3	13.9	0.81
	100	30	2	42.9	17.5	UCCX06	CX06	UCX06	25.7	15.4	13.9	1.3
	100	28	2	43	17	UCC306	C306	UC306	26.7	15.0	13.3	1.7
35	90	28	2	42.9	17.5	UCC207	C207	UC207	25.7	15.4	13.9	0.93
	110	34	2	49.2	19	UCCX07	CX07	UCX07	29.1	17.8	14.0	1.7
	110	32	3	48	19	UCC307	C307	UC307	33.4	19.3	13.2	2.2
40	100	30	2	49.2	19	UCC208	C208	UC208	29.1	17.8	14.0	1.2
	120	38	2	49.2	19	UCCX08	CX08	UCX08	32.7	20.3	14.0	2.3
	120	34	3	52	19	UCC308	C308	UC308	40.7	24.0	13.2	2.2
45	110	31	2	49.2	19	UCC209	C209	UC209	32.7	20.3	14.0	1.5
	120	38	2	51.6	19	UCCX09	CX09	UCX09	35.1	23.3	14.4	2.3
	130	38	3	57	22	UCC309	C309	UC309	48.9	29.5	13.3	2.8
50	120	33	2	51.6	19	UCC210	C210	UC210	35.1	23.3	14.4	2.0
	130	40	2.5	55.6	22.2	UCCX10	CX10	UCX10	43.4	29.4	14.4	2.8
	140	40	3	61	22	UCC310	C310	UC310	62.0	38.3	13.2	3.2

- [Remarks] 1) Applicable sizes of grease nipples are shown below.
A-1/4-28UNF..... 201~213, X05~X12, 305~308
A-PT 1/8 309~328
- 2) For bearings with double- or triple-lip seals, unit and bearing number are suffixed by L2 or L3.
(UCC206JL3, UC206L3)
- 3) For more detailed information, refer to ball bearing for unit specification tables.

d 55 ~ 130 mm

Tolerances for housing

unit : mm

housing No.			ΔH_s	ΔA_s	Y
C204~ C205			0 -0.030	±0.2	0.2
C206~ C210	CX05~ CX08	C305~ C308	0 -0.035		
	CX09~ CX10	C309~ C310	0 -0.040	±0.3	0.3
C211~ C213	CX11~ CX12	C311~ C314			
		C315~ C318 C319	0 -0.046		
		C320~ C322 C324~ C328	0 -0.052 0 -0.057		0.4

ΔH_s : deviation of outside diameter.
 ΔA_s : deviation of width.
 Y : circumferential runout tolerances of outside diameter in respect to shaft straight line of spherical bearing seating.

Shaft dia. (mm) d	Dimensions (mm)					Unit No.	Housing No.	No.	Applicable bearing		Factor f_0	(Refer.) Unit mass (kg)
	H	A	r	B	S				Basic load ratings (kN) C_r C_{0r}			
55	125	35	2.5	55.6	22.2	UCC211	C211	UC211	43.4	29.4	14.4	2.2
	150	42	2.5	65.1	25.4	UCCX11	CX11	UCX11	52.4	36.2	14.4	4.0
	150	44	3	66	25	UCC311	C311	UC311	71.6	45.0	13.2	3.9
60	130	38	2.5	65.1	25.4	UCC212	C212	UC212	52.4	36.2	14.4	2.6
	160	44	2.5	65.1	25.4	UCCX12	CX12	UCX12	57.2	40.1	14.4	4.6
	160	46	3	71	26	UCC312	C312	UC312	81.9	52.2	13.2	4.8
65	140	40	2.5	65.1	25.4	UCC213	C213	UC213	57.2	40.1	14.4	3.0
	170	50	3	75	30	UCC313	C313	UC313	92.7	59.9	13.2	5.7
70	180	52	3	78	33	UCC314	C314	UC314	104	68.2	13.2	6.7
75	190	55	4	82	32	UCC315	C315	UC315	113	77.2	13.2	7.8
80	200	60	4	86	34	UCC316	C316	UC316	123	86.7	13.3	9.2
85	215	64	4	96	40	UCC317	C317	UC317	133	96.8	13.3	11.7
90	225	66	4	96	40	UCC318	C318	UC318	143	107	13.3	13.1
95	240	72	4	103	41	UCC319	C319	UC319	153	119	13.3	15.8
100	260	75	4	108	42	UCC320	C320	UC320	173	141	13.2	19.6
105	260	75	4	112	44	UCC321	C321	UC321	184	153	13.2	27.0
110	300	80	5	117	46	UCC322	C322	UC322	205	180	13.2	29.2
120	320	90	5	126	51	UCC324	C324	UC324	207	185	13.5	35.9
130	340	100	6	135	54	UCC326	C326	UC326	229	214	13.6	43.0

Ball bearing units cartridge type UCC (with set screws)

d 140 mm

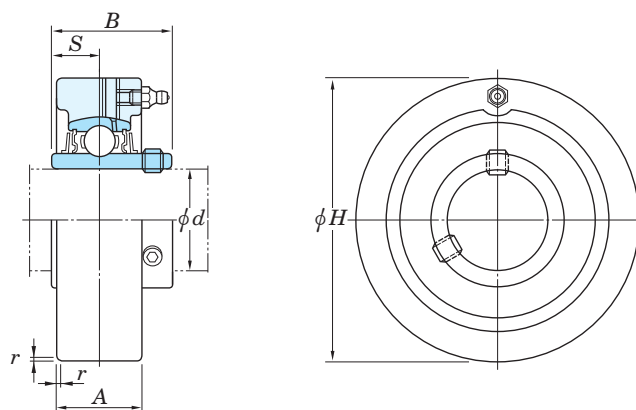

Shaft dia. (mm) d	Dimensions (mm)					Unit No.	Housing No.	No.	Applicable bearing		Factor f_0	(Refer.) Unit mass (kg)
	H	A	r	B	S				Basic load ratings (kN) C_r C_{0r}			
140	360	100	6	145	59	UCC328	C328	UC328	253	246	13.6	52.9

- [Remarks]
- 1) Applicable sizes of grease nipples are shown below.
A-1/4-28UNF..... 201~213, X05~X12, 305~308
A-PT 1/8 309~328
 - 2) For bearings with double- or triple-lip seals, unit and bearing number are suffixed by L2 or L3.
(UCC206JL3, UC206L3)
 - 3) For more detailed information, refer to ball bearing for unit specification tables.

Tolerances for housing

unit : mm

housing No.			ΔH_s	ΔA_s	Y
C204~ C205			0 -0.030	±0.2	0.2
C206~ C210	CX05~ CX08	C305~ C308	0 -0.035		
C211~ C213	CX09~ CX10	C309~ C310	0 -0.040	±0.3	0.3
	CX11~ CX12	C311~ C314			
		C315~ C318	0 -0.046		0.4
		C319			
		C320~ C322	0 -0.052		
		C324~ C328	0 -0.057		

ΔH_s : deviation of outside diameter.

ΔA_s : deviation of width.

Y : circumferential runout tolerances of outside diameter in respect to shaft straight line of spherical bearing seating.

Ball bearings for units cylindrical bore type (with set screws)

d 8 ~ (35) mm

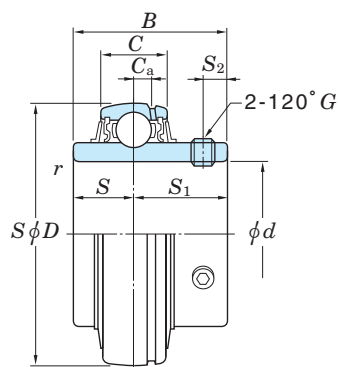

UC

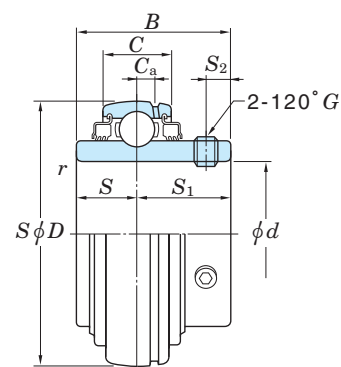

UC-L3

Shaft dia. (mm) d	Boundary dimensions (mm)				Basic load ratings (kN)		Factor f_0	Bearing No.	
	D	B	C	$r_{\min.}$	C_r	C_{0r}		With standard seals	With triple-lip seals
8	22	12	7	0.3	3.27	1.37	12.4	SU08	—
10	26	15	8	0.3	4.55	1.95	12.3	SU000	—
12	28	15	8	0.3	5.10	2.40	13.2	SU001	—
	40	22	12	0.6	9.55	4.80	13.2	SB201	—
	47	31	16	0.6	12.8	6.65	13.2	UC201	UC201L2
15	32	16.5	9	0.3	5.60	2.85	13.9	SU002	—
	40	22	12	0.6	9.55	4.80	13.2	SB202	—
	47	31	16	0.6	12.8	6.65	13.2	UC202	UC202L2
17	35	17.5	10	0.3	6.00	3.25	14.4	SU003	—
	40	22	12	0.6	9.55	4.80	13.2	SB203	—
	47	31	16	0.6	12.8	6.65	13.2	UC203	UC203L2
20	42	21	12	0.6	9.40	5.05	13.9	SU004	—
	47	25	14	1	12.8	6.65	13.2	SB204	—
	47	31	16	1	12.8	6.65	13.2	UC204	UC204L2
25	47	22	12	0.6	10.1	5.85	14.5	SU005	—
	52	27	15	1	14.0	7.85	13.9	SB205	—
	52	34.1	17	1	14.0	7.85	13.9	UC205	UC205L2
	62	38	22	1.1	21.2	10.9	13.2	UC305	—
	62	38.1	19	1	19.5	11.3	13.9	UCX05	UCX05L3
30	55	24.5	13	1	13.2	8.25	14.7	SU006	—
	62	30	16	1	19.5	11.3	13.9	SB206	—
	62	38.1	19	1	19.5	11.3	13.9	UC206	UC206L3
	72	42.9	20	1	25.7	15.4	13.9	UCX06	UCX06L3
	72	43	24	1.1	26.7	15.0	13.3	UC306	—
35	72	32	17	1.1	25.7	15.4	13.9	SB207	—

[Remarks] 1) SU type bearings are ball bearings for compact series units.
2) UC201 to UC205 are with double-lip seals.

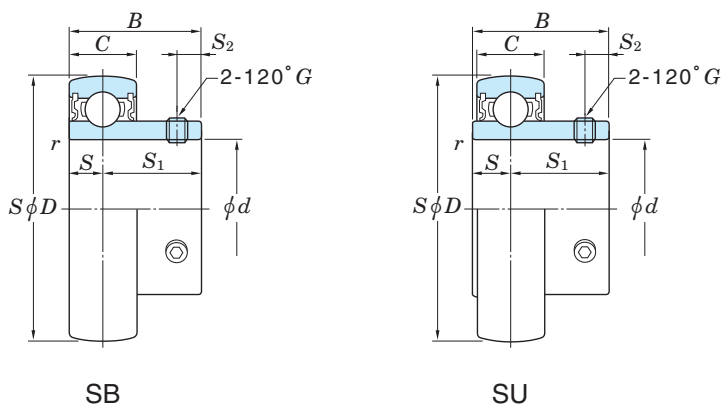

SB

SU

	Dimensions (mm)				Set screw size <i>G</i>	(Refer.) Mass (kg)
	<i>C_a</i>	<i>S</i>	<i>S₁</i>	<i>S₂</i>		
	—	3.5	8.5	2.8	M3×0.35	0.012
	—	5	10	3	M3×0.35	0.024
	—	5	10	3	M3×0.35	0.026
	—	6	16	4	M5×0.5	0.10
	4	12.7	18.3	5	M6×0.75	0.21
	—	5.5	11	3.3	M4×0.5	0.038
	—	6	16	4	M5×0.5	0.10
	4	12.7	18.3	5	M6×0.75	0.19
	—	6	11.5	3.3	M4×0.5	0.050
	—	6	16	4	M5×0.5	0.10
	4	12.7	18.3	5	M6×0.75	0.18
	—	7	14	4	M5×0.5	0.080
	—	7	18	5	M6×0.75	0.15
	4	12.7	18.3	5	M6×0.75	0.16
	—	7	15	4.5	M5×0.5	0.10
	—	7.5	19.5	5.5	M6×0.75	0.18
	3.5	14.3	19.8	5.5	M6×0.75	0.20
	5	15	23	6	M6×0.75	0.45
	4.5	15.9	22.2	6	M6×0.75	0.39
	—	7.5	17	5.5	M5×0.5	0.15
	—	8	22	6	M6×0.75	0.27
	4.5	15.9	22.2	6	M6×0.75	0.32
	4.5	17.5	25.4	6.5	M8×1	0.58
	5.5	17	26	6	M6×0.75	0.56
	—	8.5	23.5	6	M6×0.75	0.42

Ball bearings for units cylindrical bore type (with set screws)

d (35) ~ (75) mm

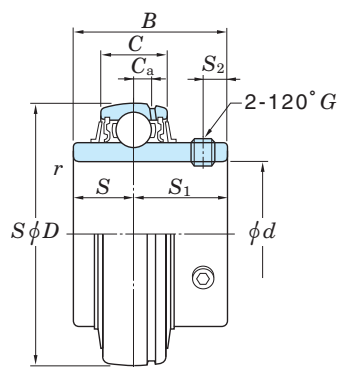

UC

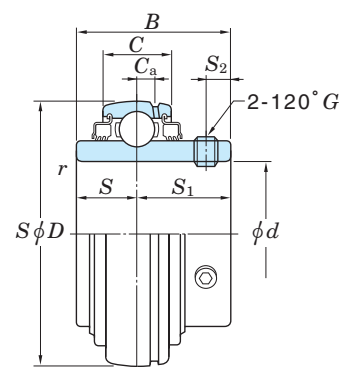

UC-L3

Shaft dia. (mm) d	Boundary dimensions (mm)				Basic load ratings (kN)		Factor f_0	Bearing No.	
	D	B	C	$r_{\min.}$	C_r	C_{0r}		With standard seals	With triple-lip seals
35	72	42.9	20	1.1	25.7	15.4	13.9	UC207	UC207L3
	80	48	26	1.5	33.4	19.3	13.2	UC307	UC307L3
	80	49.2	21	1.1	29.1	17.8	14.0	UCX07	UCX07L3
40	80	34	18	1.1	29.1	17.8	14.0	SB208	—
	80	49.2	21	1.1	29.1	17.8	14.0	UC208	UC208L3
	85	49.2	22	1.1	32.7	20.3	14.0	UCX08	UCX08L3
	90	52	28	1.5	40.7	24.0	13.2	UC308	UC308L3
45	85	49.2	22	1.1	32.7	20.3	14.0	UC209	UC209L3
	90	51.6	24	1.1	35.1	23.3	14.4	UCX09	UCX09L3
	100	57	30	1.5	48.9	29.5	13.3	UC309	UC309L3
50	90	51.6	24	1.1	35.1	23.3	14.4	UC210	UC210L3
	100	55.6	25	1.1	43.4	29.4	14.4	UCX10	UCX10L3
	110	61	32	2	62.0	38.3	13.2	UC310	UC310L3
55	100	55.6	25	1.5	43.4	29.4	14.4	UC211	UC211L3
	110	65.1	27	1.5	52.4	36.2	14.4	UCX11	UCX11L3
	120	66	34	2	71.6	45.0	13.2	UC311	UC311L3
60	110	65.1	27	1.5	52.4	36.2	14.4	UC212	UC212L3
	120	65.1	28	1.5	57.2	40.1	14.4	UCX12	UCX12L3
	130	71	36	2.1	81.9	52.2	13.2	UC312	UC312L3
65	120	65.1	28	1.5	57.2	40.1	14.4	UC213	UC213L3
	125	74.6	30	1.5	62.2	44.1	14.5	UCX13	UCX13L3
	140	75	38	2.1	92.7	59.9	13.2	UC313	UC313L3
70	125	74.6	30	1.5	62.2	44.1	14.5	UC214	UC214L3
	130	77.8	32	1.5	67.4	48.3	14.5	UCX14	UCX14L3
	150	78	40	2.1	104	68.2	13.2	UC314	UC314L3
75	130	77.8	32	1.5	67.4	48.3	14.5	UC215	UC215L3

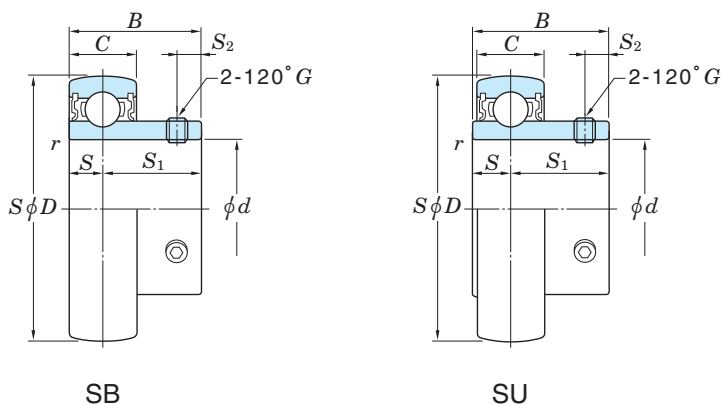

SB

SU

	Dimensions (mm)				Set screw size G	(Refer.) Mass (kg)
	C_a	S	S_1	S_2		
	4.5	17.5	25.4	6.5	M8×1	0.48
	5.5	19	29	8	M8×1	0.71
	4.5	19	30.2	8	M8×1	0.75
	—	9	25	8	M8×1	0.60
	4.5	19	30.2	8	M8×1	0.64
	5	19	30.2	8	M8×1	0.83
	6	19	33	10	M10×1.25	1.00
	5	19	30.2	8	M8×1	0.68
	6	19	32.6	9	M10×1.25	0.95
	6.5	22	35	10	M10×1.25	1.33
	6	19	32.6	9	M10×1.25	0.80
	5.5	22.2	33.4	9	M10×1.25	1.29
	7	22	39	12	M12×1.5	1.69
	5.5	22.2	33.4	9	M10×1.25	1.11
	6	25.4	39.7	10.5	M10×1.25	1.80
	7	25	41	12	M12×1.5	1.90
	6	25.4	39.7	10.5	M10×1.25	1.54
	6.5	25.4	39.7	12	M12×1.5	2.05
	6.5	26	45	12	M12×1.5	2.60
	6.5	25.4	39.7	12	M12×1.5	1.86
	6	30.2	44.4	12	M12×1.5	2.52
	7	30	45	12	M12×1.5	3.16
	6	30.2	44.4	12	M12×1.5	2.05
	7	33.3	44.5	12	M12×1.5	2.74
	7.5	33	45	12	M12×1.5	3.90
	7	33.3	44.5	12	M12×1.5	2.21

Ball bearings for units cylindrical bore type (with set screws)

d (75) ~ 140 mm

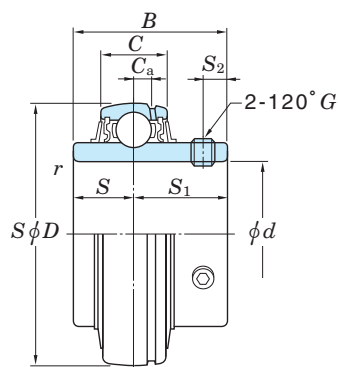

UC

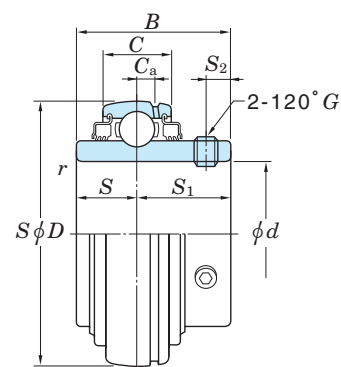

UC-L3

Shaft dia. (mm) d	Boundary dimensions (mm)				Basic load ratings (kN)		Factor f_0	Bearing No.	
	D	B	C	$r_{\min.}$	C_r	C_{0r}		With standard seals	With triple-lip seals
75	140	82.6	33	1.5	72.7	53.0	14.6	UCX15	UCX15L3
	160	82	42	2.1	113	77.2	13.2	UC315	UC315L3
80	140	82.6	33	2	72.7	53.0	14.6	UC216	UC216L3
	150	85.7	35	2	84.0	61.9	14.5	UCX16	UCX16L3
	170	86	44	2.1	123	86.7	13.3	UC316	UC316L3
85	150	85.7	35	2	84.0	61.9	14.5	UC217	UC217L3
	160	96	38	2	96.1	71.5	14.5	UCX17	UCX17L3
	180	96	46	3	133	96.8	13.3	UC317	UC317L3
90	160	96	38	2	96.1	71.5	14.5	UC218	UC218L3
	170	104	40	2	109	81.9	14.4	UCX18	—
	190	96	48	3	143	107	13.3	UC318	UC318L3
95	200	103	50	3	153	119	13.3	UC319	UC319L3
100	190	117.5	43	2.1	133	105	14.4	UCX20	—
	215	108	54	3	173	141	13.2	UC320	UC320L3
105	225	112	56	3	184	153	13.2	UC321	—
110	240	117	60	3	205	180	13.2	UC322	UC322L3
120	260	126	64	3	207	185	13.5	UC324	UC324L3
130	280	135	68	4	229	214	13.6	UC326	UC326L3
140	300	145	72	4	253	246	13.6	UC328	UC328L3

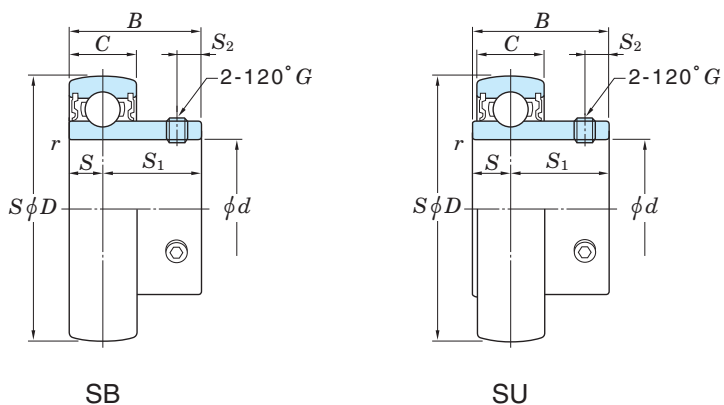

SB

SU

	Dimensions (mm)				Set screw size G	(Refer.) Mass (kg)
	C_a	S	S_1	S_2		
	7.5	33.3	49.3	14	M12×1.5	3.41
	6.5	32	50	14	M14×1.5	4.70
	7.5	33.3	49.3	14	M12×1.5	2.79
	7.5	34.1	51.6	14	M12×1.5	3.87
	7	34	52	14	M14×1.5	5.60
	7.5	34.1	51.6	14	M12×1.5	3.45
	8	39.7	56.3	15	M12×1.5	5.05
	8	40	56	16	M16×1.5	6.90
	8	39.7	56.3	15	M12×1.5	4.35
	8.5	42.9	61.1	16	M14×1.5	6.00
	8.5	40	56	16	M16×1.5	7.87
	8.5	41	62	18	M16×1.5	8.91
	8.5	49.2	68.3	18	M16×1.5	8.56
	9	42	66	20	M18×1.5	11.2
	9	44	68	20	M18×1.5	12.7
	10	46	71	20	M18×1.5	15.1
	11	51	75	20	M18×1.5	19.0
	12	54	81	20	M20×1.5	23.6
	13	59	86	20	M20×1.5	29.4

Ball bearings for units tapered bore type (with adapter)

d_1 20 ~ 55 mm

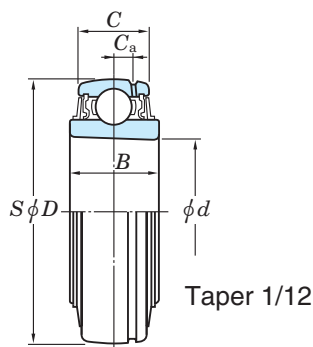

UK

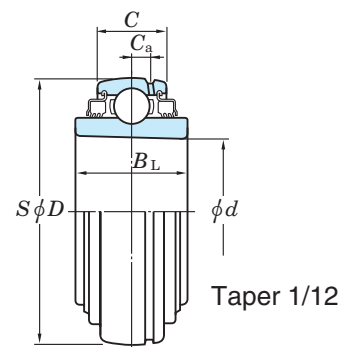

UK...L3
(with triple-lip seals)

Shaft dia. (mm)	Boundary dimensions (mm)						Basic load ratings (kN)		Factor f_0	Bearing No.		(Refer.) Mass (kg)	
	d_1	d	D	B	B_L	C	C_a	C_r		C_{0r}	With standard seals	With triple-lip seals	With standard seals
20	25	52	21	24	17	5	14.0	7.85	13.9	UK205	UK205L2	0.16	0.18
	25	62	23	—	19	5	19.5	11.3	13.9	UKX05	—	0.27	—
	25	62	27	—	22	6	21.2	10.9	12.6	UK305	—	0.40	—
25	30	62	23	27	19	5	19.5	11.3	13.9	UK206	UK206L3	0.25	0.29
	30	72	26	—	20	5.5	25.7	15.4	13.9	UKX06	—	0.43	—
	30	72	30	—	24	6.5	26.7	15.0	13.3	UK306	—	0.47	—
30	35	72	26	30	20	5.5	25.7	15.4	13.9	UK207	UK207L3	0.37	0.43
	35	80	27	—	21	6	29.1	17.8	14.0	UKX07	—	0.53	—
	35	80	33	33	26	7.5	33.4	19.3	13.2	UK307	UK307L3	0.60	—
35	40	80	27	34	21	6	29.1	17.8	14.0	UK208	UK208L3	0.47	0.58
	40	85	29	—	22	6	32.7	20.3	14.0	UKX08	—	0.58	—
	40	90	35	35	28	8	40.7	24.0	13.2	UK308	UK308L3	0.80	—
40	45	85	29	36	22	6	32.7	20.3	14.0	UK209	UK209L3	0.52	0.65
	45	90	29	—	24	6	35.1	23.3	14.4	UKX09	—	0.67	—
	45	100	38	38	30	8.5	48.9	29.5	13.3	UK309	UK309L3	1.08	—
45	50	90	29	36	24	6	35.1	23.3	14.4	UK210	UK210L3	0.59	0.65
	50	100	31	—	25	7	43.4	29.4	14.4	UKX10	—	0.89	—
	50	110	40	40	32	9	62.0	38.3	13.2	UK310	UK310L3	1.38	—
50	55	100	31	40	25	7	43.4	29.4	14.4	UK211	UK211L3	0.80	1.09
	55	110	33	—	27	7.5	52.4	36.2	14.4	UKX11	—	1.15	—
	55	120	43	43	34	10	71.6	45.0	13.2	UK311	UK311L3	1.78	—
55	60	110	33	47	27	7.5	52.4	36.2	14.4	UK212	UK212L3	1.02	1.41
	60	120	36	—	28	7.5	57.2	40.1	14.4	UKX12	—	1.45	—
	60	130	47	47	36	11.5	81.9	52.2	13.2	UK312	UK312L3	2.06	—

- [Remarks] 1) For bearings with adapters, bearing numbers shown in dimension tables are suffixed by applicable adapter assembly numbers.
(UK206+H306X, UK206L3+H2306X)
- 2) Adapter assemblies applicable to UK 2 series are classified as follows.
UK2..... H3 series
UK2...L3 H23 series

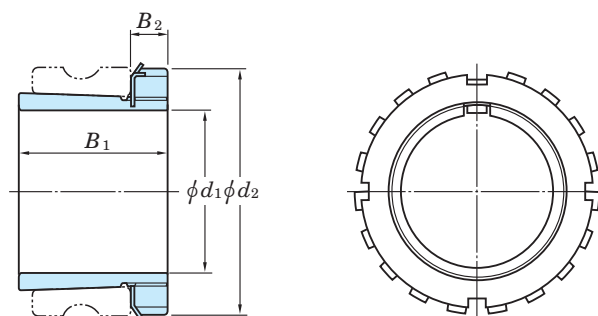

Adapter assembly

	Applicable adapter assembly (H3 series ¹⁾)					Applicable adapter assembly (H23 series ¹⁾)						
	No.	Dimensions (mm)			Mass (kg)	Sleeve No.	No.	Dimensions (mm)			Mass (kg)	Sleeve No.
		B_1	B_2	d_2			B_1	B_2	d_2			
	H305X	29	8	38	0.085	A305X	H2305X	35	8	38	0.097	A2305X
	—	—	—	—	—	—	H2305X	35	8	38	0.097	A2305X
	—	—	—	—	—	—	H2305X	35	8	38	0.097	A2305X
	H306X	31	8	45	0.11	A306X	H2306X	38	8	45	0.13	A2306X
	—	—	—	—	—	—	H2306X	38	8	45	0.13	A2306X
	—	—	—	—	—	—	H2306X	38	8	45	0.13	A2306X
	H307X	35	9	52	0.16	A307X	H2307X	43	9	52	0.19	A2307X
	—	—	—	—	—	—	H2307X	43	9	52	0.19	A2307X
	—	—	—	—	—	—	H2307X	43	9	52	0.19	A2307X
	H308X	36	10	58	0.20	A308X	H2308X	46	10	58	0.24	A2308X
	—	—	—	—	—	—	H2308X	46	10	58	0.24	A2308X
	—	—	—	—	—	—	H2308X	46	10	58	0.24	A2308X
	H309X	39	11	65	0.27	A309X	H2309X	50	11	65	0.31	A2309X
	—	—	—	—	—	—	H2309X	50	11	65	0.31	A2309X
	—	—	—	—	—	—	H2309X	50	11	65	0.31	A2309X
	H310X	42	12	70	0.32	A310X	H2310X	55	12	70	0.39	A2310X
	—	—	—	—	—	—	H2310X	55	12	70	0.39	A2310X
	—	—	—	—	—	—	H2310X	55	12	70	0.39	A2310X
	H311X	45	12	75	0.37	A311X	H2311X	59	12	75	0.45	A2311X
	—	—	—	—	—	—	H2311X	59	12	75	0.45	A2311X
	—	—	—	—	—	—	H2311X	59	12	75	0.45	A2311X
	H312X	47	13	80	0.42	A312X	H2312X	62	13	80	0.51	A2312X
	—	—	—	—	—	—	H2312X	62	13	80	0.51	A2312X
	—	—	—	—	—	—	H2312X	62	13	80	0.51	A2312X

3) UK205 is with double-lip seals.

4) Please consult with JTEKT when using adapter with inch series bore diameter.

Ball bearings for units tapered bore type (with adapter)

d_1 60 ~ 125 mm

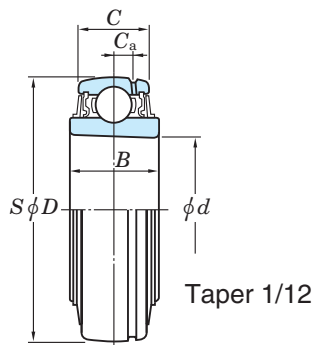

UK

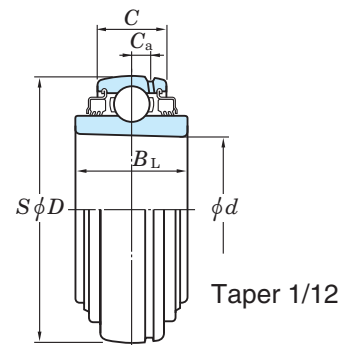

UK...L3
(with triple-lip seals)

Shaft dia. (mm)	Boundary dimensions (mm)						Basic load ratings (kN)		Factor f_0	Bearing No.		(Refer.) Mass (kg)	
	d_1	d	D	B	B_L	C	C_a	C_r		C_{0r}	With standard seals	With triple-lip seals	With standard seals
60	65	120	36	47	28	7.5	57.2	40.1	14.4	UK213	UK213L3	1.34	1.67
	65	125	40	—	30	9	62.2	44.1	14.5	UKX13	—	1.62	—
	65	140	49	49	38	12	92.7	59.9	13.2	UK313	UK313L3	2.71	—
65	75	130	40	51	32	9	67.4	48.3	14.5	UK215	UK215L3	1.50	1.99
	75	140	42	—	33	9	72.7	53.0	14.6	UKX15	—	2.10	—
	75	160	55	55	42	14.5	113	77.2	13.2	UK315	UK315L3	3.80	—
70	80	140	42	55	33	9	72.7	53.0	14.6	UK216	UK216L3	1.96	2.56
	80	150	44	—	35	10	84.0	61.9	14.5	UKX16	—	2.64	—
	80	170	55	55	44	15	123	86.7	13.3	UK316	UK316L3	4.39	—
75	85	150	44	57	35	10	84.0	61.9	14.5	UK217	UK217L3	2.42	3.10
	85	160	48	—	38	11	96.1	71.5	14.5	UKX17	—	3.25	—
	85	180	60	60	46	15	133	96.8	13.3	UK317	UK317L3	5.30	—
80	90	160	48	63	38	11	96.1	71.5	14.5	UK218	UK218L3	2.90	3.77
	90	170	50	—	40	11.5	109	81.9	14.4	UKX18	—	3.80	—
	90	190	60	60	48	15.5	143	107	13.3	UK318	UK318L3	6.20	—
85	95	200	66	66	50	16.5	153	119	13.3	UK319	UK319L3	7.31	—
90	100	190	54	—	43	13	133	105	14.4	UKX20	—	5.36	—
	100	215	68	68	54	18	173	141	13.2	UK320	UK320L3	8.70	—
100	110	240	78	78	60	20	205	180	13.2	UK322	UK322L3	12.2	—
110	120	260	87	87	64	21	207	185	13.5	UK324	UK324L3	16.1	—
115	130	280	87	87	68	22	229	214	13.6	UK326	UK326L3	18.8	—
125	140	300	97	97	72	23	253	246	13.6	UK328	UK328L3	23.9	—

[Remarks] 1) For bearings with adapters, bearing numbers shown in dimension tables are suffixed by applicable adapter assembly numbers.

(UK206+H306X, UK206L3+H2306X)

2) Adapter assemblies applicable to UK 2 series are classified as follows.

UK2..... H3 series
UK2...L3 H23 series

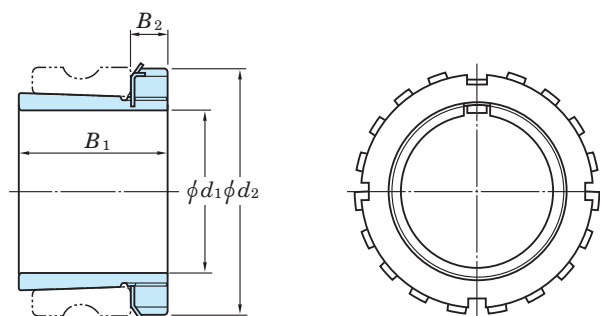

Adapter assembly

	Applicable adapter assembly (H3 series ¹⁾)						Applicable adapter assembly (H23 series ¹⁾)					
	No.	Dimensions (mm)			Mass (kg)	Sleeve No.	No.	Dimensions (mm)			Mass (kg)	Sleeve No.
		B_1	B_2	d_2			B_1	B_2	d_2			
	H313X	50	14	85	0.49	A313X	H2313X	65	14	85	0.59	A2313X
	—	—	—	—	—	—	H2313X	65	14	85	0.59	A2313X
	—	—	—	—	—	—	H2313X	65	14	85	0.59	A2313X
	H315X	55	15	98	0.89	A315X	H2315X	73	15	98	1.11	A2315X
	—	—	—	—	—	—	H2315X	73	15	98	1.11	A2315X
	—	—	—	—	—	—	H2315X	73	15	98	1.11	A2315X
	H316X	59	17	105	1.09	A316X	H2316X	78	17	105	1.34	A2316X
	—	—	—	—	—	—	H2316X	78	17	105	1.34	A2316X
	—	—	—	—	—	—	H2316X	78	17	105	1.34	A2316X
	H317X	63	18	110	1.24	A317X	H2317X	82	18	110	1.52	A2317X
	—	—	—	—	—	—	H2317X	82	18	110	1.52	A2317X
	—	—	—	—	—	—	H2317X	82	18	110	1.52	A2317X
	H318X	65	18	120	1.45	A318X	H2318X	86	18	120	1.70	A2318X
	—	—	—	—	—	—	H2318X	86	18	120	1.70	A2318X
	—	—	—	—	—	—	H2318X	86	18	120	1.70	A2318X
	—	—	—	—	—	—	H2319X	90	19	125	1.99	A2319X
	—	—	—	—	—	—	H2320X	97	20	130	2.28	A2320X
	—	—	—	—	—	—	H2320X	97	20	130	2.28	A2320X
	—	—	—	—	—	—	H2322X	105	21	145	2.87	A2322X
	—	—	—	—	—	—	H2324X	112	22	155	3.32	A2324X
	—	—	—	—	—	—	H2326	121	23	165	4.82	A2326
	—	—	—	—	—	—	H2328	131	24	180	5.86	A2328

3) Please consult with JTEKT when using adapter with inch series bore diameter.

Ball bearings for units cylindrical bore type (with eccentric locking collar)

d 20 ~ 60 mm

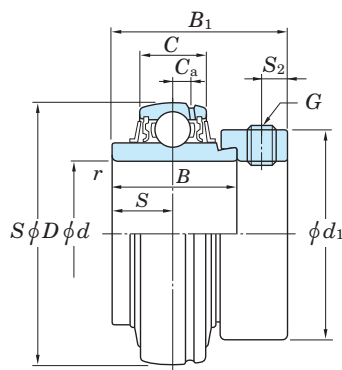

NA

Shaft dia. (mm) d	Boundary dimensions (mm)					Basic load ratings (kN)		Factor f_0	Bearing No.
	D	B	B_1	C	r min.	C_r	C_{0r}		
20	47	34.2	43.7	16	1	12.8	6.65	13.2	NA204
25	52	34.9	44.4	17	1	14.0	7.85	13.9	NA205
30	62	36.5	48.4	19	1	19.5	11.3	13.9	NA206
35	72	37.6	51.1	20	1.1	25.7	15.4	13.9	NA207
40	80	42.8	56.3	21	1.1	29.1	17.8	14.0	NA208
45	85	42.8	56.3	22	1.1	32.7	20.3	14.0	NA209
50	90	49.2	62.7	24	1.1	35.1	23.3	14.4	NA210
55	100	55.5	71.4	25	1.5	43.4	29.4	14.4	NA211
60	110	61.9	77.8	27	1.5	52.4	36.2	14.4	NA212

	Dimensions (mm)				Set screw size	(Refer.) Mass
	C_a	S	S_2	d_1	G	(kg)
	4	17.1	4.8	33.3	M6×0.75	0.22
	5	17.5	4.8	38.1	M6×0.75	0.25
	5	18.3	6	44.5	M8×1	0.41
	5.5	18.8	6.8	55.6	M8×1	0.61
	6	21.4	6.8	60.3	M8×1	0.78
	6	21.4	6.8	63.5	M8×1	0.85
	6	24.6	6.8	69.9	M8×1	1.01
	7	27.8	8	76.2	M10×1.25	1.39
	7.5	31	8	84.2	M10×1.25	1.87

KOYO

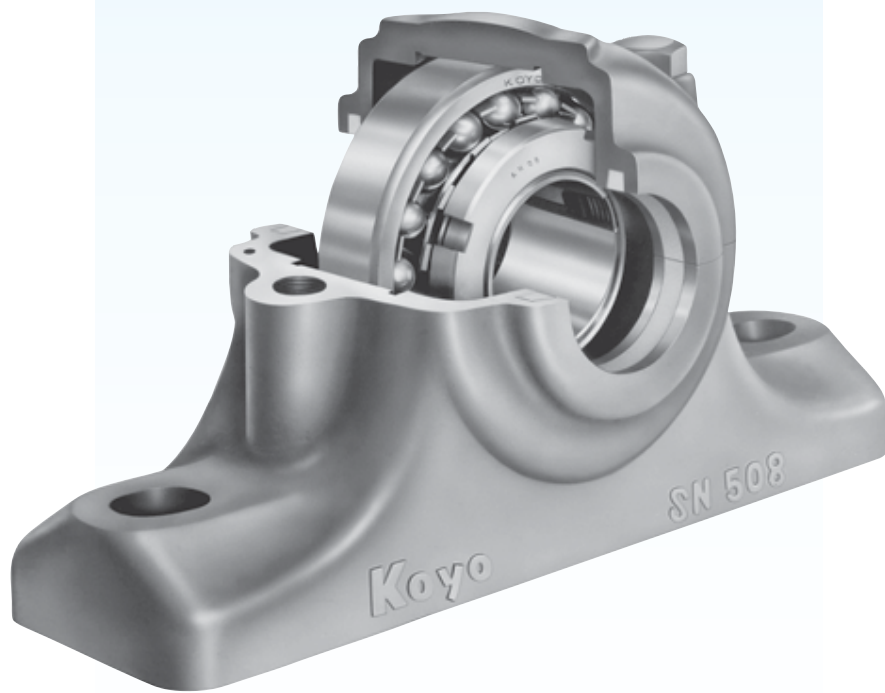

Plummer blocks

Plummer blocks consist of self-aligning ball bearings or spherical roller bearings, and a housing in which the bearings are installed. The housing varies in shape. Having a large load capacity and being easy to handle, plummer blocks are employed in a variety of industrial machines, such as carrying machines.

Split type : standard

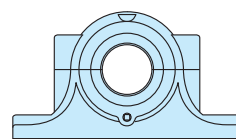

Bore diameter 20 – 170 mm

Split type : flat bottom

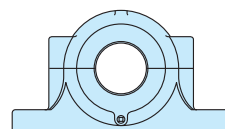

Bore diameter 20 – 140 mm

Split type : flat bottom

(different bore diameter type/
large bore diameter type)

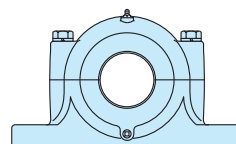

Bore diameter 25 – 160 mm

Split type : large size

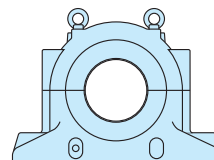

Bore diameter 150 – 360 mm

One-piece type

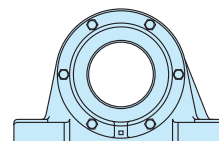

Bore diameter 20 – 170 mm

Table 1 Plummer block types

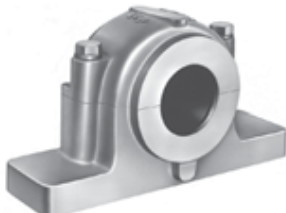
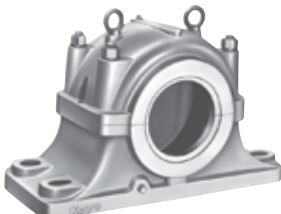
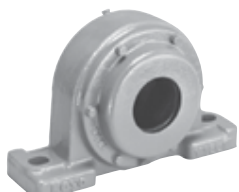
Housing type		Applicable bearing series (plummer block unit series number)	
		Self-aligning ball bearing	Spherical roller bearing
Split type : standard (SN) 	<div style="border: 1px solid black; padding: 2px; display: inline-block;">SN5</div> <div style="border: 1px solid black; padding: 2px; display: inline-block;">SN6</div> <div style="border: 1px solid black; padding: 2px; display: inline-block;">SN33</div> <div style="border: 1px solid black; padding: 2px; display: inline-block;">SN34</div>	12K(SN15), 22K(SN25) 13K(SN16), 23K(SN26) — —	222K(SN225), 232K(SN235) 213K(SN216), 223K(SN226) 230K(SN233) 231K(SN234)
	<div style="border: 1px solid black; padding: 5px; width: fit-content; margin: 0 auto;">Small-or medium-size ; most general</div>		
Split type : flat bottom (SSN) 	<div style="border: 1px solid black; padding: 2px; display: inline-block;">SSN5</div> <div style="border: 1px solid black; padding: 2px; display: inline-block;">SSN6</div> * <div style="border: 1px solid black; padding: 2px; display: inline-block;">SSN2</div> * <div style="border: 1px solid black; padding: 2px; display: inline-block;">SSN3</div> ** <div style="border: 1px solid black; padding: 2px; display: inline-block;">SSN2B</div> ** <div style="border: 1px solid black; padding: 2px; display: inline-block;">SSN3B</div>	12K(SSN15), 22K(SSN25) 13K(SSN16), 23K(SSN26) 12 (SSN12), 22 (SSN22) 13 (SSN13), 23 (SSN23) 12 (SSN12B), 22 (SSN22B) 13 (SSN13B), 23 (SSN23B)	222K(SSN225), 232K(SSN235) 213K(SSN216), 223K(SSN226) 222 (SSN222), 232 (SSN232) 213 (SSN213), 223 (SSN223) 222 (SSN222B), 232 (SSN232B) 213 (SSN213B), 223 (SSN223B)
	<div style="border: 1px solid black; padding: 5px; width: fit-content; margin: 0 auto;"> <ul style="list-style-type: none"> ● Has a flat bottom and is more heavy-duty than the SN type. ● Optionally, bolt holes can be provided. </div>		
Split type : large size (SD) 	<div style="border: 1px solid black; padding: 2px; display: inline-block;">SD5</div> <div style="border: 1px solid black; padding: 2px; display: inline-block;">SD6</div> <div style="border: 1px solid black; padding: 2px; display: inline-block;">SD31L</div> <div style="border: 1px solid black; padding: 2px; display: inline-block;">SD33</div> <div style="border: 1px solid black; padding: 2px; display: inline-block;">SD34</div>	— — — — —	222K(SD225) 223K(SD226) 231K(SD231L) 230K(SD233) 231K(SD234)
	<div style="border: 1px solid black; padding: 5px; width: fit-content; margin: 0 auto;">Large size and most suitable for applications which involve heavy loading.</div>		
One-piece type (V) 	<div style="border: 1px solid black; padding: 2px; display: inline-block;">V5</div> <div style="border: 1px solid black; padding: 2px; display: inline-block;">V6</div> * V2 * V3	12K(V15), 22K(V25) 13K(V16), 23K(V26) 12 (V12), 22 (V22) 13 (V13), 23 (V23)	222K(V225), 232K(V235) 213K(V216), 223K(V226) 222 (V222), 232 (V232) 213 (V213), 223 (V223)
	<div style="border: 1px solid black; padding: 5px; width: fit-content; margin: 0 auto;"> <ul style="list-style-type: none"> ● Has a monolithic housing. ● Excellent processing performance and high rigidity. </div>		

[Notes] * "Different bore diameter type," whose bore diameter of housing or cover differs from side to side.
A cylindrical bore bearing is attached to a stepped shaft with a locknut and lockwasher.

** "Large bore diameter type," whose housing or cover has a large-diameter bore.
A cylindrical bore bearing is attached to the small side of a stepped shaft with a concentric collar.

[Remark] This catalog includes major types of plummer blocks which are boxed in the table above.
For other series and special series, refer to separate catalogs.

Table 2 Split plummer block housing dimensional tolerance (JIS B 1551)

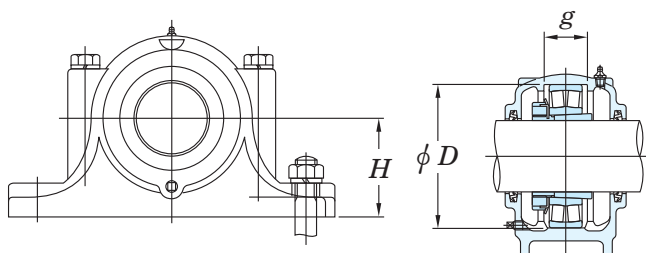

Housing series	Bearing seating bore diameter D	Bearing seating width g	Center height H
SN5, SN6 SN33, SN34 SSN5, SSN6 SSN2, SSN3 SD5, SD6 SD33, SD34 SD31L	H8	H13	h13

Table 4 Stabilizing ring dimensional tolerance

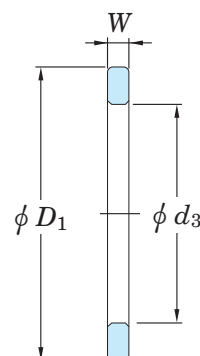

Unit : mm

Outside diameter D_1	Bore diameter d_3	Width W
h12	(SR47 × 5 to SR130 × 12.5) ± 0.8	0
	(SR140 × 8.5 to SR340 × 10) ± 1.2	- 0.2

[Remark] Stabilizing ring is installed in bearing seating of plummer block, on the fixed side. It prevents bearing from moving in the axial direction.

Table 3 One-piece plummer block housing dimensional tolerance (BAS 188)

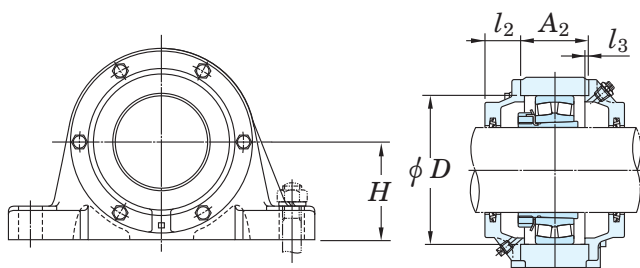

Unit : mm

Housing series	Bearing seating bore diameter D	Bearing seating width A_2	Center height H	Cover size l_2	Cover spigot joint height l_3
V5, V6 V2, V3	H7	+ 0.2 0	h11	± 1	0 - 0.2

[Remark] The degree of parallelism between the bottom surface and bearing seating center line should be 1/2 000 or less.

Refer to Table 7-3 on pp. A 54 to A 57 for the dimensional tolerance of self-aligning ball bearings and spherical roller bearings which are used with plummer blocks. Refer to Table 7-11 on p. A 70 for tapered bore tolerances.

Plummer blocks

split type, standard

SN 5, 6, 33, 34

d_1 20 ~ (60) mm

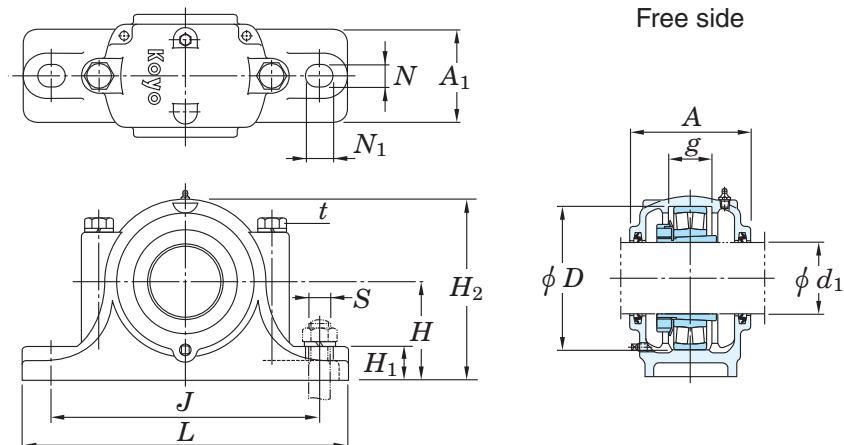

Shaft dia. (mm) d_1	Dimensions (mm)												Bolt size S	Housing No.
	D	H	J	L	A	A_1	H_1	H_2	N	N_1	g	t Bolt size		
20	52	40	130	165	67	46	22	75	15	20	25	M8	M12	SN505
	62	50	150	185	80	52	22	90	15	20	34	M8	M12	SN605
25	62	50	150	185	77	52	22	90	15	20	30	M8	M12	SN506
	72	50	150	185	82	52	22	95	15	20	37	M10	M12	SN606
30	72	50	150	185	82	52	22	95	15	20	33	M10	M12	SN507
	80	60	170	205	90	60	25	110	15	20	41	M10	M12	SN607
35	80	60	170	205	85	60	25	110	15	20	33	M10	M12	SN508
	90	60	170	205	95	60	25	115	15	20	43	M10	M12	SN608
40	85	60	170	205	85	60	25	112	15	20	31	M10	M12	SN509
	100	70	210	255	105	70	28	130	18	23	46	M12	M16	SN609
45	90	60	170	205	90	60	25	115	15	20	33	M10	M12	SN510
	110	70	210	255	115	70	30	135	18	23	50	M12	M16	SN610
50	100	70	210	255	95	70	28	130	18	23	33	M12	M16	SN511
	120	80	230	275	120	80	30	150	18	23	53	M12	M16	SN611
55	110	70	210	255	105	70	30	135	18	23	38	M12	M16	SN512
	130	80	230	280	125	80	30	155	18	23	56	M12	M16	SN612
60	120	80	230	275	110	80	30	150	18	23	43	M12	M16	SN513

[Note] 1) Dimension x shows the shear between center of bearing and housing when one stabilizing ring is used. The value is 1/2 the width dimension of stabilizing ring.
When mounting two stabilizing rings, x becomes equal to 0, since they are mounted to each side of bearing.

Fixed side
(When one stabilizing ring used)

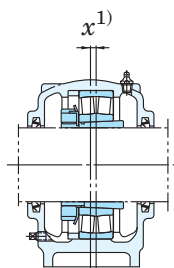

Stabilizing ring

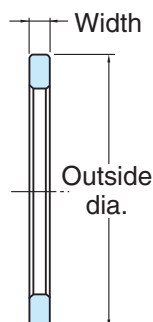

	(Refer.) Housing mass (kg)	Grease nipple size	Drain plug size	Applicable bearing No.		Applicable adapter ass'y No.	Applicable stabilizing ring		Applicable oil seal No. MZ
				Self-aligning ball brg.	Spherical roller brg.		No.	Qty.	
	1.2	R 1/8	R 1/8	1205K 2205K	— 22205RHRK	H205X H305X	SR52×5 SR52×7	2 1	MZ05
	1.8	R 1/8	R 1/8	1305K 2305K	—	H305X H2305X	SR62×8.5 SR62×10	2 1	MZ05
	1.9	R 1/8	R 1/8	1206K 2206K	— 22206RHRK	H206X H306X	SR62×7 SR62×10	2 1	MZ06
	2.1	R 1/8	R 1/8	1306K 2306K	—	H306X H2306X	SR72×9 SR72×10	2 1	MZ06
	2.3	R 1/8	R 1/8	1207K 2207K	— 22207RHRK	H207X H307X	SR72×8 SR72×10	2 1	MZ07
	2.6	R 1/8	R 1/8	1307K 2307K	—	H307X H2307X	SR80×10 SR80×10	2 1	MZ07
	2.4	R 1/8	R 1/8	1208K 2208K	— 22208RHRK	H208X H308X	SR80×7.5 SR80×10	2 1	MZ08
	2.8	R 1/8	R 1/8	1308K 2308K	21308RHK 22308RHRK	H308X H2308X	SR90×10 SR90×10	2 1	MZ08
	2.7	R 1/8	R 1/8	1209K 2209K	— 22209RHRK	H209X H309X	SR85×6 SR85×8	2 1	MZ09
	4.3	R 1/8	R 1/8	1309K 2309K	21309RHK 22309RHRK	H309X H2309X	SR100×10.5 SR100×10	2 1	MZ09
	3.5	R 1/8	R 1/8	1210K 2210K	— 22210RHRK	H210X H310X	SR90×6.5 SR90×10	2 1	MZ10
	4.7	R 1/8	R 1/8	1310K 2310K	21310RHK 22310RHRK	H310X H2310X	SR110×11.5 SR110×10	2 1	MZ10
	3.7	R 1/8	R 1/8	1211K 2211K	— 22211RHRK	H211X H311X	SR100×6 SR100×8	2 1	MZ11
	5.8	R 1/8	R 1/8	1311K 2311K	21311RHK 22311RHRK	H311X H2311X	SR120×12 SR120×10	2 1	MZ11
	4.4	R 1/8	R 1/8	1212K 2212K	— 22212RHRK	H212X H312X	SR110×8 SR110×10	2 1	MZ12
	6.4	R 1/8	R 1/8	1312K 2312K	21312RHK 22312RHRK	H312X H2312X	SR130×12.5 SR130×10	2 1	MZ12
	5.4	R 1/8	R 1/8	1213K 2213K	— 22213RHRK	H213X H313X	SR120×10 SR120×12	2 1	MZ13

[Remark] Housings shown below are equipped with eyebolts.
SN524~SN532, SN620~SN632, SN3328~SN3338, SN3426~SN3438

Plummer blocks

split type, standard

SN 5, 6, 33, 34

d_1 (60) ~ (110) mm

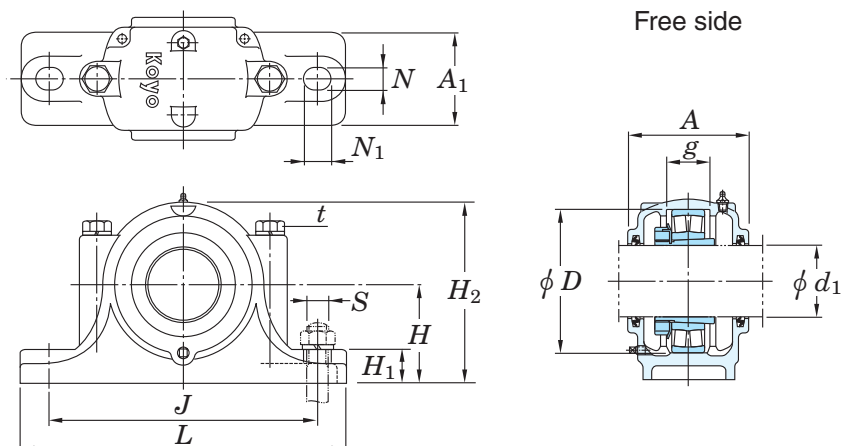

Shaft dia. (mm) d_1	Dimensions (mm)												Bolt size S	Housing No.
	D	H	J	L	A	A_1	H_1	H_2	N	N_1	g	t Bolt size		
60	140	95	260	315	130	90	32	175	22	27	58	M16	M20	SN613
	160	100	290	345	140	100	35	195	22	27	65	M16	M20	SN615
70	140	95	260	315	120	90	32	175	22	27	43	M16	M20	SN516
	170	112	290	345	145	100	35	212	22	27	68	M16	M20	SN616
75	150	95	260	320	125	90	32	185	22	27	46	M16	M20	SN517
	180	112	320	380	155	110	40	223	26	32	70	M20	M24	SN617
80	160	100	290	345	145	100	35	195	22	27	62.4	M16	M20	SN518
	190	112	320	380	160	110	40	230	26	32	74	M20	M24	SN618
85	170	112	290	345	140	100	35	210	22	27	53	M16	M20	SN519
	200	125	350	410	170	120	45	250	26	32	77	M20	M24	SN619
90	180	112	320	380	160	110	40	223	26	32	70.3	M20	M24	SN520
	215	140	350	410	175	120	45	270	26	32	83	M20	M24	SN620
100	180	112	320	380	155	110	40	223	26	32	66	M20	M24	SN3422
	200	125	350	410	175	120	45	245	26	32	80	M20	M24	SN522
	240	150	390	450	190	130	50	300	28	36	90	M24	M24	SN622
110	180	112	320	380	150	110	40	223	26	32	56	M20	M24	SN3324

[Note] 1) Dimension x shows the shear between center of bearing and housing when one stabilizing ring is used. The value is 1/2 the width dimension of stabilizing ring.
When mounting two stabilizing rings, x becomes equal to 0, since they are mounted to each side of bearing.

Fixed side
(When one stabilizing ring used)

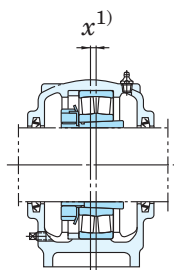

Stabilizing ring

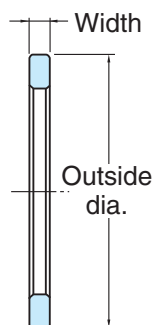

	(Refer.) Housing mass (kg)	Grease nipple size	Drain plug size	Applicable bearing No.		Applicable adapter ass'y No.	Applicable stabilizing ring		Applicable oil seal No. MZ
				Self-aligning ball brg.	Spherical roller brg.		No.	Qty.	
	8.6	R 1/8	R 1/8	1313K 2313K	21313RHK 22313RHRK	H313X H2313X	SR140×12.5 SR140×10	2 1	MZ13
	6.1	R 1/8	R 1/8	1215K 2215K	— 22215RHRK	H215X H315X	SR130×8 SR130×10	2 1	MZ15
	11.8	R 1/8	R 1/8	1315K 2315K	21315RHK 22315RHRK	H315X H2315X	SR160×14 SR160×10	2 1	MZ15
	8.2	R 1/8	R 1/8	1216K 2216K	— 22216RHRK	H216X H316X	SR140×8.5 SR140×10	2 1	MZ16
	13.6	R 1/8	R 1/8	1316K 2316K	21316RHK 22316RHRK	H316X H2316X	SR170×14.5 SR170×10	2 1	MZ16
	9.3	R 1/8	R 1/8	1217K 2217K	— 22217RHRK	H217X H317X	SR150×9 SR150×10	2 1	MZ17
	16.8	R 1/8	R 1/8	1317K 2317K	21317RHK 22317RHRK	H317X H2317X	SR180×14.5 SR180×10	2 1	MZ17
	12	R 1/8	R 1/8	1218K 2218K —	— 22218RHRK 23218RHK	H218X H318X H2318X	SR160×16.2 SR160×11.2 SR160×10	2 2 1	MZ18
	21	R 1/4	R 1/4	1318K 2318K	— 22318RHRK	H318X H2318X	SR190×15.5 SR190×10	2 1	MZ18
	13	R 1/8	R 1/8	1219K 2219K	— 22219RHRK	H219X H319X	SR170×10.5 SR170×10	2 1	MZ19
	23	R 1/4	R 1/4	1319K 2319K	— 22319RHRK	H319X H2319X	SR200×16 SR200×10	2 1	MZ19
	17	R 1/4	R 1/4	1220K 2220K —	— 22220RHRK 23220RHK	H220X H320X H2320X	SR180×18.1 SR180×12.1 SR180×10	2 2 1	MZ20
	31	R 1/4	R 1/4	1320K 2320K	— 22320RHRK	H320X H2320X	SR215×18 SR215×10	2 1	MZ20
	20	R 1/4	R 1/4	—	23122RHK	H3122X	SR180×10	1	MZ22
	20	R 1/4	R 1/4	1222K 2222K —	— 22222RHRK 23222RHK	H222X H322X H2322X	SR200×21 SR200×13.5 SR200×10	2 2 1	MZ22
	38	R 1/4	R 1/4	1322K 2322K	— 22322RHRK	H322X H2322X	SR240×20 SR240×10	2 1	MZ22
	19	R 1/4	R 1/4	—	23024RHK	H3024	SR180×10	1	MZ24

[Remark] Housings shown below are equipped with eyebolts.
SN524~SN532, SN620~SN632, SN3328~SN3338, SN3426~SN3438

Plummer blocks

split type, standard

SN 5, 6, 33, 34

d_1 (110) ~ (140) mm

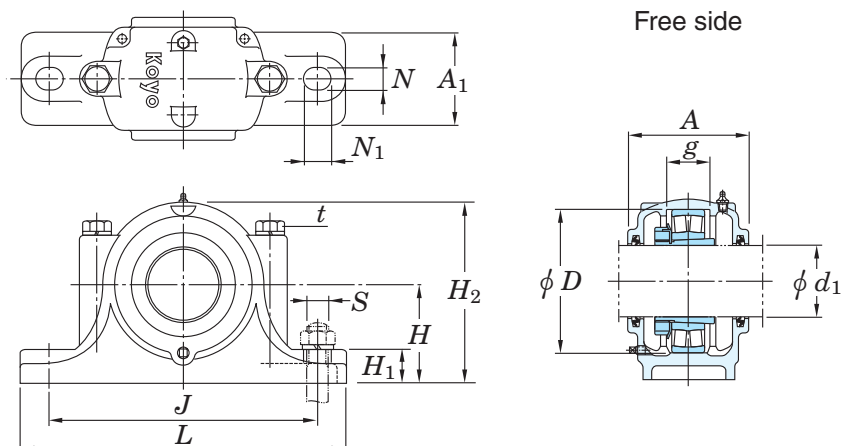

Shaft dia. (mm) d_1	Dimensions (mm)												Bolt size S	Housing No.
	D	H	J	L	A	A_1	H_1	H_2	N	N_1	g	t Bolt size		
110	200	125	350	410	165	120	45	245	26	32	72	M20	M24	SN3424
	215	140	350	410	185	120	45	270	26	32	86	M20	M24	SN524
	260	160	450	530	200	160	60	320	33	42	96	M24	M30	SN624
115	200	125	350	410	160	120	45	245	26	32	62	M20	M24	SN3326
	210	140	350	410	170	120	45	270	26	32	74	M20	M24	SN3426
	230	150	380	445	190	130	50	290	28	36	90	M24	M24	SN526
	280	170	470	550	210	160	60	340	33	42	103	M24	M30	SN626
125	210	140	350	410	170	120	45	270	26	32	63	M20	M24	SN3328
	225	150	380	445	180	130	50	290	28	36	78	M24	M24	SN3428
	250	150	420	500	205	150	50	305	33	42	98	M24	M30	SN528
	300	180	520	610	235	170	65	365	35	45	112	M30	M30	SN628
135	225	150	380	445	175	130	50	290	28	36	66	M24	M24	SN3330
	250	150	420	500	200	150	50	305	33	42	90	M24	M30	SN3430
	270	160	450	530	220	160	60	325	33	42	106	M24	M30	SN530
	320	190	560	650	245	180	65	385	35	45	118	M30	M30	SN630
140	240	150	390	450	190	130	50	300	28	36	70	M24	M24	SN3332
	270	160	450	530	215	160	60	325	33	42	96	M24	M30	SN3432

[Note] 1) Dimension x shows the shear between center of bearing and housing when one stabilizing ring is used. The value is 1/2 the width dimension of stabilizing ring.
When mounting two stabilizing rings, x becomes equal to 0, since they are mounted to each side of bearing.

Fixed side
(When one stabilizing ring used)

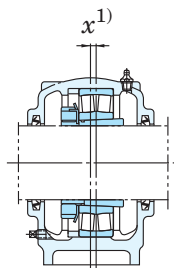

Stabilizing ring

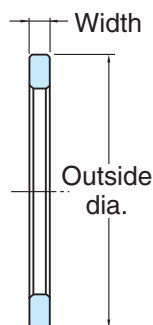

	(Refer.) Housing mass (kg)	Grease nipple size	Drain plug size	Applicable bearing No.		Applicable adapter ass'y No.	Applicable stabilizing ring		Applicable oil seal No. MZ
				Self-aligning ball brg.	Spherical roller brg.		No. Outside dia.×Width	Qty.	
	22	R 1/4	R 1/4	—	23124RHK	H3124	SR200×10	1	MZ24
	23	R 1/4	R 1/4	—	22224RHRK 23224RHK	H3124 H2324	SR215×14 SR215×10	2 1	MZ24
	48	R 1/4	R 1/4	—	22324RHRK	H2324	SR260×10	1	MZ24
	21	R 1/4	R 1/4	—	23026RHK	H3026	SR200×10	1	MZ26
	29	R 1/4	R 1/4	—	23126RHK	H3126	SR210×10	1	MZ26
	33	R 1/4	R 1/4	—	22226RHRK 23226RHK	H3126 H2326	SR230×13 SR230×10	2 1	MZ26
	78	R 1/4	R 1/4	—	22326RHRK	H2326	SR280×10	1	MZ26
	28	R 1/4	R 1/4	—	23028RHK	H3028	SR210×10	1	MZ28
	36	R 1/4	R 1/4	—	23128RHK	H3128	SR225×10	1	MZ28
	40	R 1/4	R 1/4	—	22228RHRK 23228RHK	H3128 H2328	SR250×15 SR250×10	2 1	MZ28
	97	R 1/4	R 1/4	—	22328RK	H2328	SR300×10	1	MZ28
	32	R 1/4	R 1/4	—	23030RHK	H3030	SR225×10	1	MZ30
	42	R 1/4	R 1/4	—	23130RHK	H3130	SR250×10	1	MZ30
	45	R 1/4	R 1/4	—	22230RHRK 23230RHK	H3130 H2330	SR270×16.5 SR270×10	2 1	MZ30
	110	R 1/4	R 1/4	—	22330RK	H2330	SR320×10	1	MZ30
	36	R 1/4	R 1/4	—	23032RHK	H3032	SR240×10	1	MZ32
	53	R 1/4	R 1/4	—	23132RHK	H3132	SR270×10	1	MZ32

[Remark] Housings shown below are equipped with eyebolts.
SN524~SN532, SN620~SN632, SN3328~SN3338, SN3426~SN3438

Plummer blocks

split type, standard

SN 5, 6, 33, 34

d_1 (140) ~ 170 mm

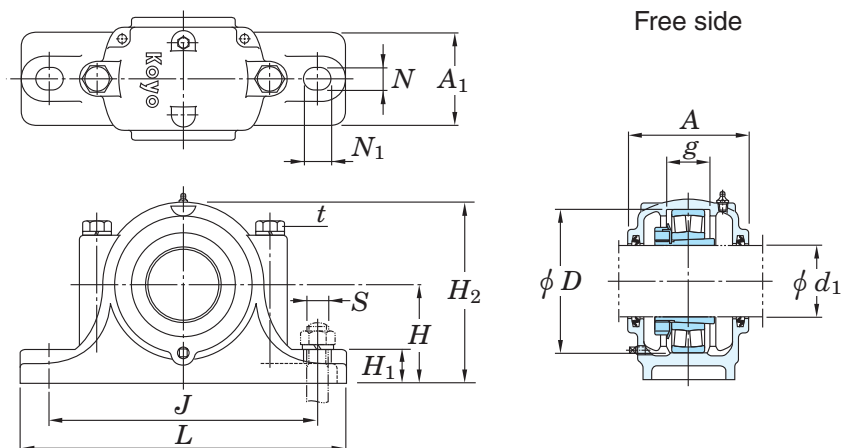

Shaft dia. (mm) d_1	Dimensions (mm)												Bolt size S	Housing No.
	D	H	J	L	A	A_1	H_1	H_2	N	N_1	g	t Bolt size		
140	290	170	470	550	235	160	60	345	33	42	114	M24	M30	SN532
	340	200	580	680	255	190	70	405	42	50	124	M30	M36	SN632
150	260	160	450	530	200	160	60	320	33	42	77	M24	M30	SN3334
	280	170	470	550	220	160	60	340	33	42	98	M24	M30	SN3434
160	280	170	470	550	210	160	60	340	33	42	84	M24	M30	SN3336
	300	180	520	610	230	170	65	365	35	45	106	M30	M30	SN3436
170	290	170	470	550	210	160	60	345	33	42	85	M24	M30	SN3338
	320	190	560	650	240	180	65	385	35	45	114	M30	M30	SN3438

[Note] 1) Dimension x shows the shear between center of bearing and housing when one stabilizing ring is used. The value is 1/2 the width dimension of stabilizing ring.
When mounting two stabilizing rings, x becomes equal to 0, since they are mounted to each side of bearing.

Fixed side
 (When one stabilizing
 ring used)

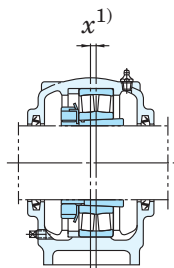

Stabilizing
 ring

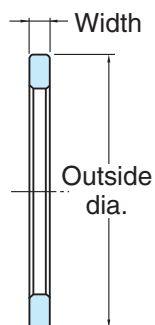

	(Refer.) Housing mass (kg)	Grease nipple size	Drain plug size	Applicable bearing No.		Applicable adapter ass'y No.	Applicable stabilizing ring		Applicable oil seal No. MZ
				Self-aligning ball brg.	Spherical roller brg.		No. Outside dia.xWidth	Qty.	
	51	R 1/4	R 1/4	—	22232RK 23232RK	H3132 H2332	SR290×17 SR290×10	2 1	MZ32
	120	R 1/4	R 1/4	—	22332RK	H2332	SR340×10	1	MZ32
	45	R 1/4	R 1/4	—	23034RHK	H3034	SR260×10	1	MZ34
	61	R 1/4	R 1/4	—	23134RHK	H3134	SR280×10	1	MZ34
	57	R 1/4	R 1/4	—	23036RHK	H3036	SR280×10	1	MZ36
	80	R 1/4	R 1/4	—	23136RK	H3136	SR300×10	1	MZ36
	59	R 1/4	R 1/4	—	23038RK	H3038	SR290×10	1	MZ38
	95	R 1/4	R 1/4	—	23138RK	H3138	SR320×10	1	MZ38

[Remark] Housings shown below are equipped with eyebolts.
 SN524~SN532, SN620~SN632, SN3328~SN3338, SN3426~SN3438

Plummer blocks

split type, flat bottom

SSN 5, 6

d_1 20 ~ (60) mm

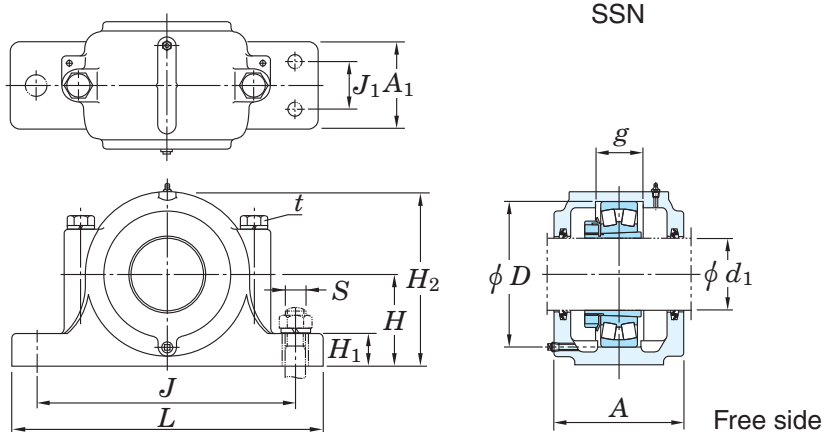

Shaft dia. (mm) d_1	Dimensions (mm)													Bolt size		Housing No.
	D	H	J	J_1	L	A	A_1	A_2	A_3	H_1	H_2	g	t Bolt size	S (Two) (Four)		
20	52	40	130	25	165	67	46	—	—	22	75	25	M8	M12	M10	SSN505
	62	50	150	25	185	80	52	—	—	22	90	34	M8	M12	M10	SSN605
25	62	50	150	25	185	77	52	—	—	22	90	30	M8	M12	M10	SSN506
	72	50	150	25	185	82	52	—	—	22	95	37	M10	M12	M10	SSN606
30	72	50	150	25	185	82	52	—	—	22	95	33	M10	M12	M10	SSN507
	80	60	170	30	205	90	60	—	—	25	110	41	M10	M12	M10	SSN607
35	80	60	170	30	205	85	60	—	—	25	110	33	M10	M12	M10	SSN508
	90	60	170	30	205	95	60	—	—	25	115	43	M10	M12	M10	SSN608
40	85	60	170	30	205	85	60	—	—	25	112	31	M10	M12	M10	SSN509
	100	70	210	35	255	105	70	—	—	28	130	46	M12	M16	M12	SSN609
45	90	60	170	30	205	90	60	—	—	25	115	33	M10	M12	M10	SSN510
	110	70	210	35	255	115	70	—	—	30	135	50	M12	M16	M12	SSN610
50	100	70	210	35	255	95	70	160	57	28	130	33	M12	M16	M12	SSN511
	120	80	230	40	275	120	80	185	70	30	150	53	M12	M16	M12	SSN611
55	110	70	210	35	255	105	70	164	62	30	135	38	M12	M16	M12	SSN512
	130	80	230	40	280	125	80	184	72	30	155	56	M12	M16	M12	SSN612
60	120	80	230	40	275	110	80	168	65	30	150	43	M12	M16	M12	SSN513

[Note] 1) Dimension x shows the shear between center of bearing and housing when one stabilizing ring is used. The value is 1/2 the width dimension of stabilizing ring.
When mounting two stabilizing rings, x becomes equal to 0, since they are mounted to each side of bearing.

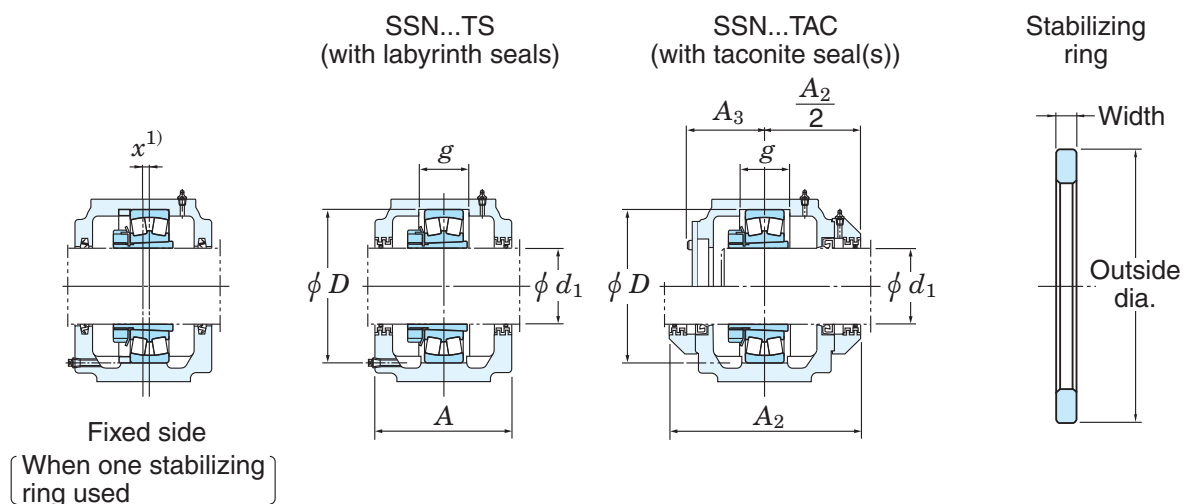

	(Refer.) Housing mass (kg)	Grease nipple size	Drain plug size	Applicable bearing No.		Applicable adapter ass'y No.	Applicable stabilizing ring No.		Applicable oil seal No. MZ
				Self-aligning ball brg.	Spherical roller brg.		Outside dia.xWidth	Qty.	
	1.8	R 1/8	R 1/8	1205K 2205K	— 22205RHRK	H205X H305X	SR52×5 SR52×7	2 1	MZ05
	2.6	R 1/8	R 1/8	1305K 2305K	—	H305X H2305X	SR62×8.5 SR62×10	2 1	MZ05
	2.7	R 1/8	R 1/8	1206K 2206K	— 22206RHRK	H206X H306X	SR62×7 SR62×10	2 1	MZ06
	2.8	R 1/8	R 1/8	1306K 2306K	—	H306X H2306X	SR72×9 SR72×10	2 1	MZ06
	3.0	R 1/8	R 1/8	1207K 2207K	— 22207RHRK	H207X H307X	SR72×8 SR72×10	2 1	MZ07
	3.8	R 1/8	R 1/8	1307K 2307K	—	H307X H2307X	SR80×10 SR80×10	2 1	MZ07
	3.8	R 1/8	R 1/8	1208K 2208K	— 22208RHRK	H208X H308X	SR80×7.5 SR80×10	2 1	MZ08
	3.9	R 1/8	R 1/8	1308K 2308K	21308RHK 22308RHRK	H308X H2308X	SR90×10 SR90×10	2 1	MZ08
	4.3	R 1/8	R 1/8	1209K 2209K	— 22209RHRK	H209X H309X	SR85×6 SR85×8	2 1	MZ09
	6.2	R 1/8	R 1/8	1309K 2309K	21309RHK 22309RHRK	H309X H2309X	SR100×10.5 SR100×10	2 1	MZ09
	5.2	R 1/8	R 1/8	1210K 2210K	— 22210RHRK	H210X H310X	SR90×6.5 SR90×10	2 1	MZ10
	6.5	R 1/8	R 1/8	1310K 2310K	21310RHK 22310RHRK	H310X H2310X	SR110×11.5 SR110×10	2 1	MZ10
	5.5	R 1/8	R 1/8	1211K 2211K	— 22211RHRK	H211X H311X	SR100×6 SR100×8	2 1	MZ11
	8.5	R 1/8	R 1/8	1311K 2311K	21311RHK 22311RHRK	H311X H2311X	SR120×12 SR120×10	2 1	MZ11
	6.3	R 1/8	R 1/8	1212K 2212K	— 22212RHRK	H212X H312X	SR110×8 SR110×10	2 1	MZ12
	8.9	R 1/8	R 1/8	1312K 2312K	21312RHK 22312RHRK	H312X H2312X	SR130×12.5 SR130×10	2 1	MZ12
	6.8	R 1/8	R 1/8	1213K 2213K	— 22213RHRK	H213X H313X	SR120×10 SR120×12	2 1	MZ13

[Remarks] 1) Use of labyrinth or taconite seals are indicated by TS or TAC suffixed to housing numbers.
 2) Housings shown below are equipped with eyebolts.
 SSN524~SSN532, SSN618~SSN632

Plummer blocks

split type, flat bottom

SSN 5, 6

d_1 (60) ~ 110 mm

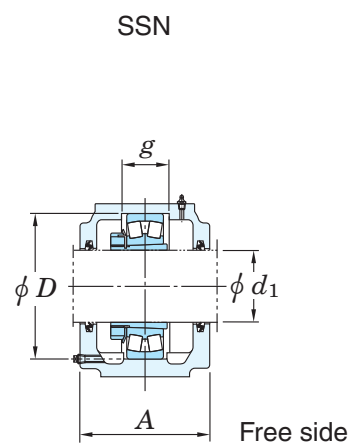
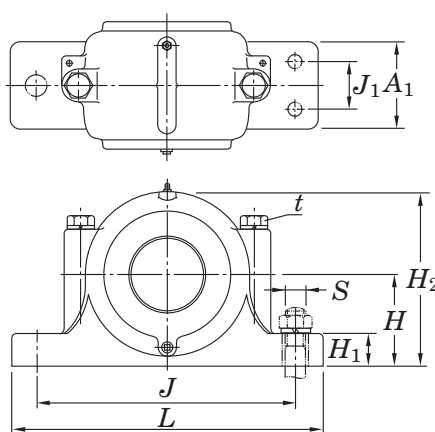

Shaft dia. (mm) d_1	Dimensions (mm)													Bolt size		Housing No.
	D	H	J	J_1	L	A	A_1	A_2	A_3	H_1	H_2	g	t Bolt size	S (Two) (Four)		
60	140	95	260	50	315	130	90	188	75	32	175	58	M16	M20	M16	SSN613
	130	80	230	40	280	115	80	172	67	30	155	41	M12	M16	M12	SSN515
65	160	100	290	50	345	140	100	197	80	35	195	65	M16	M20	M16	SSN615
	140	95	260	50	315	120	90	190	70	32	175	43	M16	M20	M16	SSN516
70	170	112	290	50	345	145	100	215	83	35	212	68	M16	M20	M16	SSN616
	150	95	260	50	320	125	90	194	75	32	185	46	M16	M20	M16	SSN517
75	180	112	320	60	380	155	110	224	90	40	223	70	M20	M24	M20	SSN617
	160	100	290	50	345	145	100	214	85	35	195	62.4	M16	M20	M16	SSN518
80	190	112	320	60	380	160	110	229	93	40	230	74	M20	M24	M20	SSN618
	170	112	290	50	345	140	100	214	85	35	210	53	M16	M20	M16	SSN519
85	200	125	350	70	410	170	120	235	98	45	250	77	M20	M24	M20	SSN619
	180	112	320	60	380	160	110	220	92	40	223	70.3	M20	M24	M16	SSN520
90	215	140	350	70	410	175	120	235	100	45	270	83	M20	M24	M20	SSN620
	200	125	350	70	410	175	120	240	100	45	245	80	M20	M24	M16	SSN522
100	240	150	390	70	450	190	130	255	108	50	300	90	M24	M24	M24	SSN622
	215	140	350	70	410	185	120	254	110	45	270	86	M20	M24	M16	SSN524
110	260	160	450	90	530	200	160	269	118	60	320	96	M24	M30	M24	SSN624

[Note] 1) Dimension x shows the shear between center of bearing and housing when one stabilizing ring is used. The value is 1/2 the width dimension of stabilizing ring. When mounting two stabilizing rings, x becomes equal to 0, since they are mounted to each side of bearing.

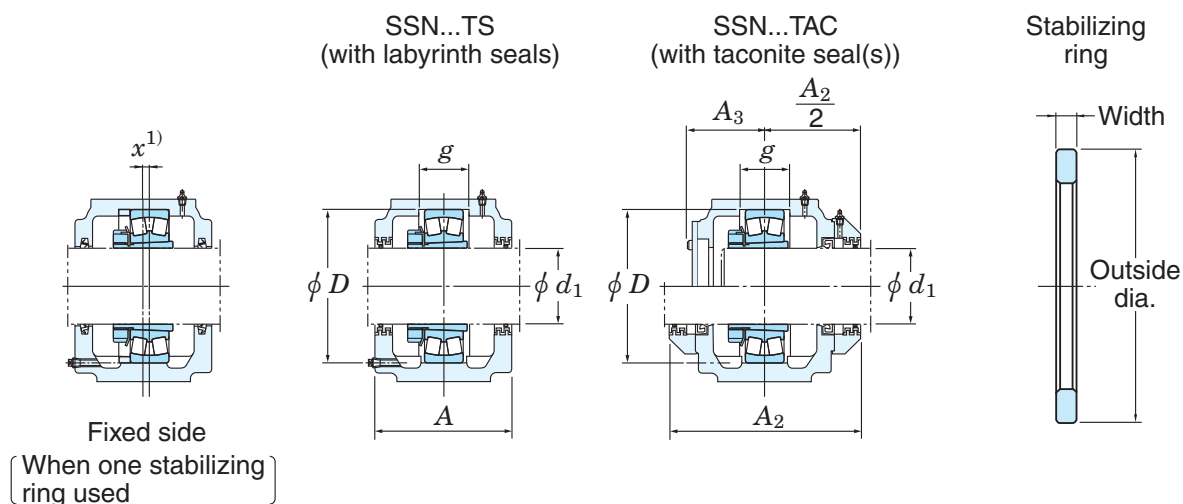

	(Refer.) Housing mass (kg)	Grease nipple size	Drain plug size	Applicable bearing No.		Applicable adapter ass'y No.	Applicable stabilizing ring No.		Applicable oil seal No. MZ
				Self-aligning ball brg.	Spherical roller brg.		Outside dia. x Width	Qty.	
	12.9	R 1/8	R 1/8	1313K 2313K	21313RHK 22313RHRK	H313X H2313X	SR140×12.5 SR140×10	2 1	MZ13
	7.9	R 1/8	R 1/8	1215K 2215K	— 22215RHRK	H215X H315X	SR130×8 SR130×10	2 1	MZ15
	16.5	R 1/8	R 1/8	1315K 2315K	21315RHK 22315RHRK	H315X H2315X	SR160×14 SR160×10	2 1	MZ15
	12	R 1/8	R 1/8	1216K 2216K	— 22216RHRK	H216X H316X	SR140×8.5 SR140×10	2 1	MZ16
	18	R 1/8	R 1/8	1316K 2316K	21316RHK 22316RHRK	H316X H2316X	SR170×14.5 SR170×10	2 1	MZ16
	13	R 1/8	R 1/8	1217K 2217K	— 22217RHRK	H217X H317X	SR150×9 SR150×10	2 1	MZ17
	25.8	R 1/8	R 1/8	1317K 2317K	21317RHK 22317RHRK	H317X H2317X	SR180×14.5 SR180×10	2 1	MZ17
	17	R 1/8	R 1/8	1218K 2218K —	— 22218RHRK 23218RHK	H218X H318X H2318X	SR160×16.2 SR160×11.2 SR160×10	2 2 1	MZ18
	28	R 1/4	R 1/4	1318K 2318K	— 22318RHRK	H318X H2318X	SR190×15.5 SR190×10	2 1	MZ18
	18	R 1/8	R 1/8	1219K 2219K	— 22219RHRK	H219X H319X	SR170×10.5 SR170×10	2 1	MZ19
	31	R 1/4	R 1/4	1319K 2319K	— 22319RHRK	H319X H2319X	SR200×16 SR200×10	2 1	MZ19
	24	R 1/4	R 1/4	1220K 2220K —	— 22220RHRK 23220RHK	H220X H320X H2320X	SR180×18.1 SR180×12.1 SR180×10	2 2 1	MZ20
	41	R 1/4	R 1/4	1320K 2320K	— 22320RHRK	H320X H2320X	SR215×18 SR215×10	2 1	MZ20
	28	R 1/4	R 1/4	1222K 2222K —	— 22222RHRK 23222RHK	H222X H322X H2322X	SR200×21 SR200×13.5 SR200×10	2 2 1	MZ22
	51	R 1/4	R 1/4	1322K 2322K	— 22322RHRK	H322X H2322X	SR240×20 SR240×10	2 1	MZ22
	33	R 1/4	R 1/4	—	22224RHRK 23224RHK	H3124 H2324	SR215×14 SR215×10	2 1	MZ24
	63	R 1/4	R 1/4	—	22324RHRK	H2324	SR260×10	1	MZ24

[Remarks] 1) Use of labyrinth or taconite seals are indicated by TS or TAC suffixed to housing numbers.
2) Housings shown below are equipped with eyebolts.
SSN524~SSN532, SSN618~SSN632

Plummer blocks

split type, flat bottom

SSN 5, 6

d_1 115 ~ 140 mm

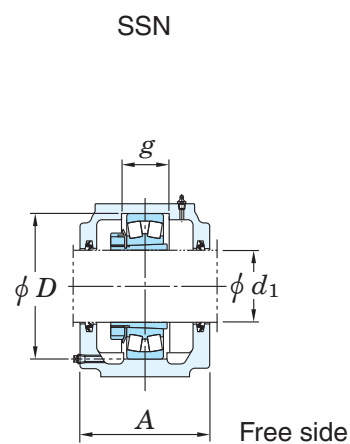
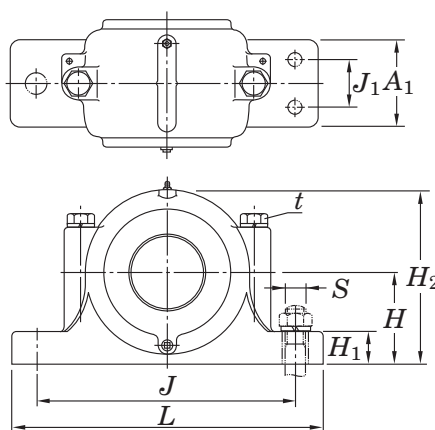

Shaft dia. (mm) d_1	Dimensions (mm)													Bolt size		Housing No.
	D	H	J	J_1	L	A	A_1	A_2	A_3	H_1	H_2	g	t Bolt size	S (Two)	S (Four)	
115	230	150	380	70	445	190	130	260	112	50	290	90	M24	M24	M20	SSN526
	280	170	470	90	550	210	160	280	122	60	340	103	M24	M30	M24	SSN626
125	250	150	420	80	500	205	150	274	120	50	305	98	M24	M30	M24	SSN528
	300	180	520	100	610	235	170	304	135	65	365	112	M30	M30	M24	SSN628
135	270	160	450	90	530	220	160	280	127	60	325	106	M24	M30	M24	SSN530
	320	190	560	110	650	245	180	310	140	65	385	118	M30	M30	M24	SSN630
140	290	170	470	90	550	235	160	300	135	60	345	114	M24	M30	M24	SSN532
	340	200	580	110	680	255	190	320	145	70	405	124	M30	M36	M30	SSN632

[Note] 1) Dimension x shows the shear between center of bearing and housing when one stabilizing ring is used. The value is 1/2 the width dimension of stabilizing ring.
When mounting two stabilizing rings, x becomes equal to 0, since they are mounted to each side of bearing.

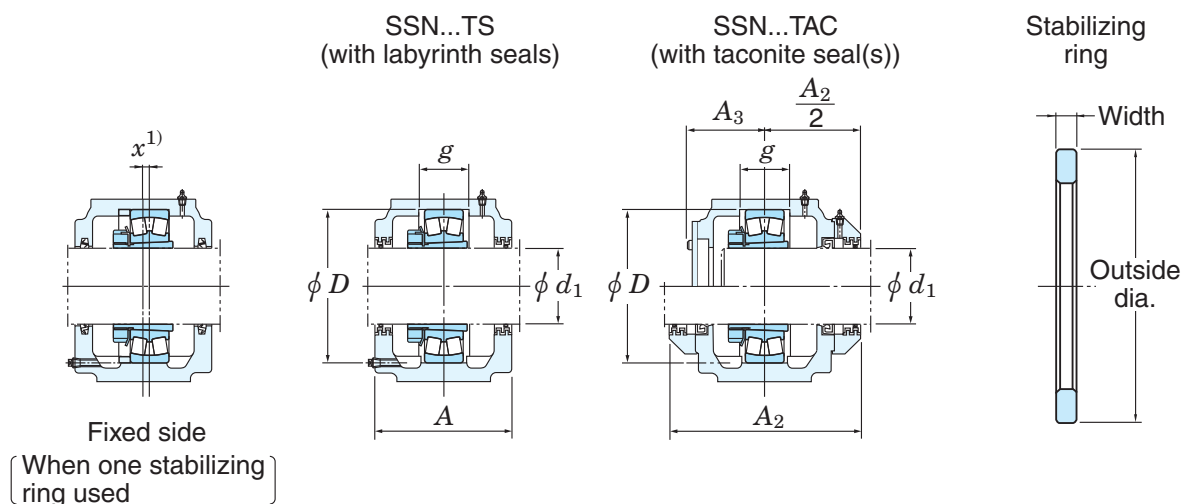

(Refer.) Housing mass (kg)	Grease nipple size	Drain plug size	Applicable bearing No.		Applicable adapter ass'y No.	Applicable stabilizing ring		Applicable oil seal No. MZ
			Self-aligning ball brg.	Spherical roller brg.		No.	Qty.	
45	R 1/4	R 1/4	—	22226RHRK 23226RHK	H3126 H2326	SR230×13 SR230×10	2 1	MZ26
96	R 1/4	R 1/4	—	22326RHRK	H2326	SR280×10	1	MZ26
54	R 1/4	R 1/4	—	22228RHRK 23228RHK	H3128 H2328	SR250×15 SR250×10	2 1	MZ28
117	R 1/4	R 1/4	—	22328RK	H2328	SR300×10	1	MZ28
60	R 1/4	R 1/4	—	22230RHRK 23230RHK	H3130 H2330	SR270×16.5 SR270×10	2 1	MZ30
132	R 1/4	R 1/4	—	22330RK	H2330	SR320×10	1	MZ30
69	R 1/4	R 1/4	—	22232RK 23232RK	H3132 H2332	SR290×17 SR290×10	2 1	MZ32
145	R 1/4	R 1/4	—	22332RK	H2332	SR340×10	1	MZ32

[Remarks] 1) Use of labyrinth or taconite seals are indicated by TS or TAC suffixed to housing numbers.
 2) Housings shown below are equipped with eyebolts.
 SSN524~SSN532, SSN618~SSN632

Plummer blocks
split type, flat bottom
different bore type
SSN 2, 3
large bore type
SSN 2B, 3B
 d_1 20 ~ (60) mm

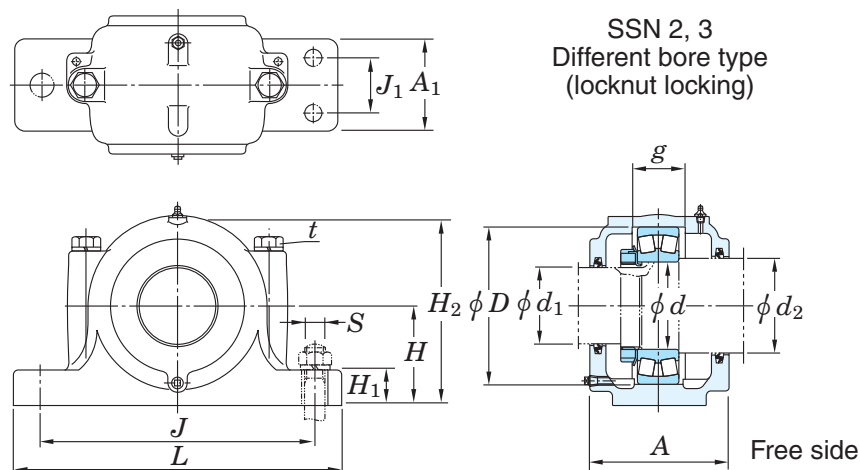

Shaft diameter (mm)			Dimensions (mm)											Bolt size		Housing No.
d_1	d	$d_2^{2)}$	D	H	J	J_1	L	A	A_1	H_1	H_2	g	t Bolt size	S (Two) (Four)		
20	25	*30	52	40	130	25	165	67	46	22	75	25	M8	M12 M10	SSN205	
	25	30	62	50	150	25	185	80	52	22	90	34	M8	M12 M10	SSN305	
25	30	*35	62	50	150	25	185	77	52	22	90	30	M8	M12 M10	SSN206	
	30	35	72	50	150	25	185	82	52	22	95	37	M10	M12 M10	SSN306	
30	35	45	72	50	150	25	185	82	52	22	95	33	M10	M12 M10	SSN207	
	35	45	80	60	170	30	205	90	60	25	110	41	M10	M12 M10	SSN307	
35	40	50	80	60	170	30	205	85	60	25	110	33	M10	M12 M10	SSN208	
	40	50	90	60	170	30	205	95	60	25	115	43	M10	M12 M10	SSN308	
40	45	55	85	60	170	30	205	85	60	25	112	31	M10	M12 M10	SSN209	
	45	55	100	70	210	35	255	105	70	28	130	46	M12	M16 M12	SSN309	
45	50	60	90	60	170	30	205	90	60	25	115	33	M10	M12 M10	SSN210	
	50	60	110	70	210	35	255	115	70	30	135	50	M12	M16 M12	SSN310	
50	55	65	100	70	210	35	255	95	70	28	130	33	M12	M16 M12	SSN211	
	55	65	120	80	230	40	275	120	80	30	150	53	M12	M16 M12	SSN311	
55	60	70	110	70	210	35	255	105	70	30	135	38	M12	M16 M12	SSN212	
	60	*70	130	80	230	40	280	125	80	30	155	56	M12	M16 M12	SSN312	
60	65	75	120	80	230	40	275	110	80	30	150	43	M12	M16 M12	SSN213	

[Notes] 1) Dimension x shows the shear between center of bearing and housing when one stabilizing ring is used. The value is 1/2 the width dimension of stabilizing ring.
 When mounting two stabilizing rings, x becomes equal to 0, since they are mounted to each side of bearing.
 2) If bearing of shaft diameter marked with * (shoulder diameter) receives large axial load, the use of spacers is recommended.

SSN 2B, 3B
Large bore type
(concentric collar locking)

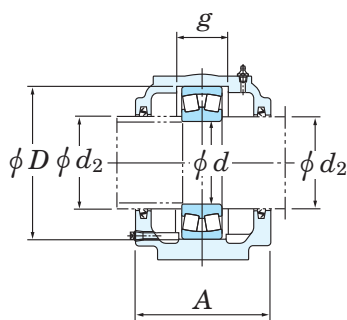
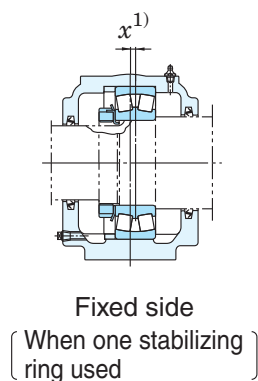

Stabilizing ring

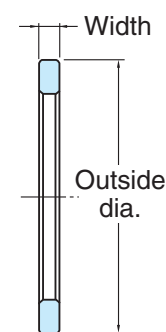

(Refer.) Housing mass (kg)	Grease nipple size	Drain plug size	Applicable bearing No.		Applicable stabilizing ring		Applicable oil seal No.	
			Self-aligning ball brg.	Spherical roller brg.	No.	Qty.	d ₁ side	d ₂ side
1.8	R 1/8	R 1/8	1205	—	SR52×5	2	MZ05	MZ07
			2205	22205RHR	SR52×7	1		
2.6	R 1/8	R 1/8	1305	—	SR62×8.5	2	MZ05	MZ07
			2305	—	SR62×10	1		
2.7	R 1/8	R 1/8	1206	—	SR62×7	2	MZ06	MZ08
			2206	22206RHR	SR62×10	1		
2.8	R 1/8	R 1/8	1306	—	SR72×9	2	MZ06	MZ08
			2306	—	SR72×10	1		
3.0	R 1/8	R 1/8	1207	—	SR72×8	2	MZ07	MZ10
			2207	22207RHR	SR72×10	1		
3.8	R 1/8	R 1/8	1307	—	SR80×10	2	MZ07	MZ10
			2307	—	SR80×10	1		
3.8	R 1/8	R 1/8	1208	—	SR80×7.5	2	MZ08	MZ11
			2208	22208RHR	SR80×10	1		
3.9	R 1/8	R 1/8	1308	21308RH	SR90×10	2	MZ08	MZ11
			2308	22308RHR	SR90×10	1		
4.3	R 1/8	R 1/8	1209	—	SR85×6	2	MZ09	MZ12
			2209	22209RHR	SR85×8	1		
6.2	R 1/8	R 1/8	1309	21309RH	SR100×10.5	2	MZ09	MZ12
			2309	22309RHR	SR100×10	1		
5.2	R 1/8	R 1/8	1210	—	SR90×6.5	2	MZ10	MZ13
			2210	22210RHR	SR90×10	1		
6.5	R 1/8	R 1/8	1310	21310RH	SR110×11.5	2	MZ10	MZ13
			2310	22310RHR	SR110×10	1		
5.5	R 1/8	R 1/8	1211	—	SR100×6	2	MZ11	MZ15
			2211	22211RHR	SR100×8	1		
8.5	R 1/8	R 1/8	1311	21311RH	SR120×12	2	MZ11	MZ15
			2311	22311RHR	SR120×10	1		
6.3	R 1/8	R 1/8	1212	—	SR110×8	2	MZ12	MZ16
			2212	22212RHR	SR110×10	1		
8.9	R 1/8	R 1/8	1312	21312RH	SR130×12.5	2	MZ12	MZ16
			2312	22312RHR	SR130×10	1		
6.8	R 1/8	R 1/8	1213	—	SR120×10	2	MZ13	MZ17
			2213	22213RHR	SR120×12	1		

- [Remarks] 1) Large bore diameter types (concentric collar locking) are identified by B suffixed to housing numbers.
2) Housings shown below are equipped with eyebolts.
SSN224~SSN232, SSN318~SSN332

Plummer blocks
split type, flat bottom
different bore type
SSN 2, 3
large bore type
SSN 2B, 3B
 d_1 (60) ~ (105) mm

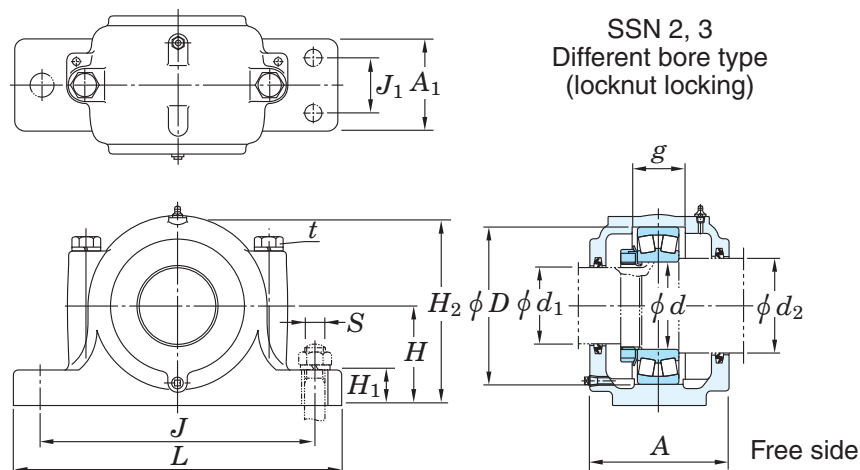

Shaft diameter (mm)			Dimensions (mm)											Bolt size		Housing No.
d_1	d	$d_2^{2)}$	D	H	J	J_1	L	A	A_1	H_1	H_2	g	t Bolt size	S (Two) (Four)		
60	65	*75	140	95	260	50	315	130	90	32	175	58	M16	M20 M16	SSN313	
65	70	80	125	80	230	40	275	115	80	30	155	44	M12	M16 M12	SSN214	
	70	*80	150	95	260	50	320	130	90	32	185	61	M16	M20 M16	SSN314	
70	75	85	130	80	230	40	280	115	80	30	155	41	M12	M16 M12	SSN215	
	75	*85	160	100	290	50	345	140	100	35	195	65	M16	M20 M16	SSN315	
75	80	90	140	95	260	50	315	120	90	32	175	43	M16	M20 M16	SSN216	
	80	*90	170	112	290	50	345	145	100	35	212	68	M16	M20 M16	SSN316	
80	85	95	150	95	260	50	320	125	90	32	185	46	M16	M20 M16	SSN217	
	85	95	180	112	320	60	380	155	110	40	223	70	M20	M24 M20	SSN317	
85	90	100	160	100	290	50	345	145	100	35	195	62.4	M16	M20 M16	SSN218	
	90	105	190	112	320	60	380	160	110	40	230	74	M20	M24 M20	SSN318	
90	95	110	170	112	290	50	345	140	100	35	210	53	M16	M20 M16	SSN219	
	95	110	200	125	350	70	410	170	120	45	250	77	M20	M24 M20	SSN319	
95	100	115	180	112	320	60	380	160	110	40	223	70.3	M20	M24 M16	SSN220	
	100	115	215	140	350	70	410	175	120	45	270	83	M20	M24 M20	SSN320	
105	110	125	200	125	350	70	410	175	120	45	245	80	M20	M24 M16	SSN222	

[Notes] 1) Dimension x shows the shear between center of bearing and housing when one stabilizing ring is used. The value is 1/2 the width dimension of stabilizing ring.
 When mounting two stabilizing rings, x becomes equal to 0, since they are mounted to each side of bearing.
 2) If bearing of shaft diameter marked with * (shoulder diameter) receives large axial load, the use of spacers is recommended.

SSN 2B, 3B
Large bore type
(concentric collar locking)

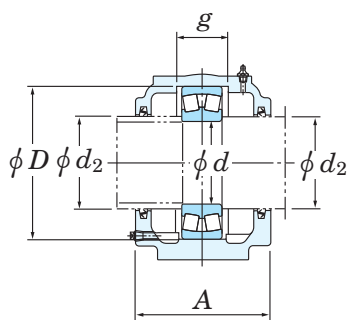
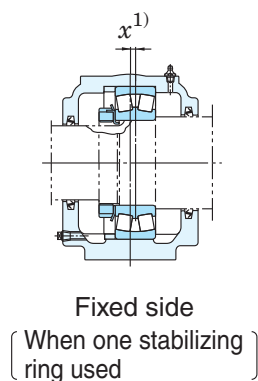

Stabilizing ring

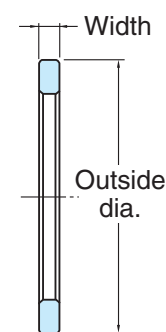

(Refer.) Housing mass (kg)	Grease nipple size	Drain plug size	Applicable bearing No.		Applicable stabilizing ring		Applicable oil seal No.	
			Self-aligning ball brg.	Spherical roller brg.	No.	Qty.	d_1 side	d_2 side
12.9	R 1/8	R 1/8	1313	21313RH	SR140×12.5	2	MZ13	MZ17
			2313	22313RHR	SR140×10	1		
7.5	R 1/8	R 1/8	1214	—	SR125×10	2	MZ15	MZ18
			2214	22214RHR	SR125×13	1		
15	R 1/8	R 1/8	1314	21314RH	SR150×13	2	MZ15	MZ18
			2314	22314RHR	SR150×10	1		
7.9	R 1/8	R 1/8	1215	—	SR130×8	2	MZ16	MZ19
			2215	22215RHR	SR130×10	1		
16.5	R 1/8	R 1/8	1315	21315RH	SR160×14	2	MZ16	MZ19
			2315	22315RHR	SR160×10	1		
12	R 1/8	R 1/8	1216	—	SR140×8.5	2	MZ17	MZ20
			2216	22216RHR	SR140×10	1		
18	R 1/8	R 1/8	1316	21316RH	SR170×14.5	2	MZ17	MZ20
			2316	22316RHR	SR170×10	1		
13	R 1/8	R 1/8	1217	—	SR150×9	2	MZ18	MZ21
			2217	22217RHR	SR150×10	1		
25.8	R 1/8	R 1/8	1317	21317RH	SR180×14.5	2	MZ18	MZ21
			2317	22317RHR	SR180×10	1		
17	R 1/8	R 1/8	1218	—	SR160×16.2	2	MZ19	MZ22
			2218	22218RHR	SR160×11.2	2		
28	R 1/4	R 1/4	—	23218RH	SR160×10	1	MZ19	MZ23
			1318	—	SR190×15.5	2		
18	R 1/8	R 1/8	2318	22318RHR	SR190×10	1	MZ20	MZ24
			1219	—	SR170×10.5	2		
31	R 1/4	R 1/4	2219	22219RHR	SR170×10	1	MZ20	MZ24
			1319	—	SR200×16	2		
24	R 1/4	R 1/4	2319	22319RHR	SR200×10	1	MZ21	MZ26
			1220	—	SR180×18.1	2		
41	R 1/4	R 1/4	2220	22220RHR	SR180×12.1	2	MZ21	MZ26
			—	23220RH	SR180×10	1		
28	R 1/4	R 1/4	1320	—	SR215×18	2	MZ23	MZ28
			2320	22320RHR	SR215×10	1		
28	R 1/4	R 1/4	1222	—	SR200×21	2	MZ23	MZ28
			2222	22222RHR	SR200×13.5	2		
—	—	—	23222RH	SR200×10	1	—	—	

- [Remarks] 1) Large bore diameter types (concentric collar locking) are identified by B suffixed to housing numbers.
2) Housings shown below are equipped with eyebolts.
SSN224~SSN232, SSN318~SSN332

Plummer blocks
split type, flat bottom
different bore type
SSN 2, 3
large bore type
SSN 2B, 3B
 d_1 (105) ~ 150 mm

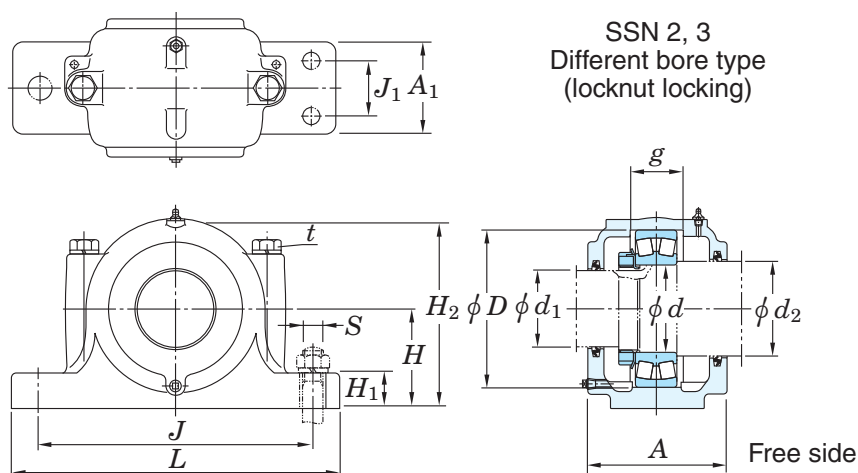

Shaft diameter (mm)	Dimensions (mm)													Bolt size		Housing No.
	d_1	d	$d_2^{(2)}$	D	H	J	J_1	L	A	A_1	H_1	H_2	g	t Bolt size	S (Two) (Four)	
105	110	125		240	150	390	70	450	190	130	50	300	90	M24	M24 M24	SSN322
115	120	135		215	140	350	70	410	185	120	45	270	86	M20	M24 M16	SSN224
	120	135		260	160	450	90	530	200	160	60	320	96	M24	M30 M24	SSN324
125	130	145		230	150	380	70	445	190	130	50	290	90	M24	M24 M20	SSN226
	130	150		280	170	470	90	550	210	160	60	340	103	M24	M30 M24	SSN326
135	140	155		250	150	420	80	500	205	150	50	305	98	M24	M30 M24	SSN228
	140	160		300	180	520	100	610	235	170	65	365	112	M30	M30 M24	SSN328
145	150	165		270	160	450	90	530	220	160	60	325	106	M24	M30 M24	SSN230
	150	170		320	190	560	110	650	245	180	65	385	118	M30	M30 M24	SSN330
150	160	175		290	170	470	90	550	235	160	60	345	114	M24	M30 M24	SSN232
	160	180		340	200	580	110	680	255	190	70	405	124	M30	M36 M30	SSN332

[Notes] 1) Dimension x shows the shear between center of bearing and housing when one stabilizing ring is used. The value is 1/2 the width dimension of stabilizing ring.
 When mounting two stabilizing rings, x becomes equal to 0, since they are mounted to each side of bearing.
 2) If bearing of shaft diameter marked with * (shoulder diameter) receives large axial load, the use of spacers is recommended.

SSN 2B, 3B Large bore type (concentric collar locking)

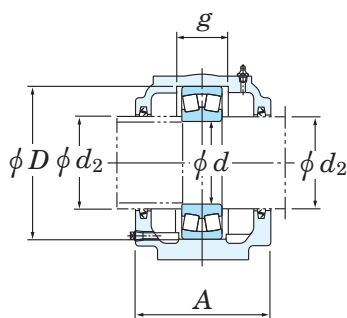
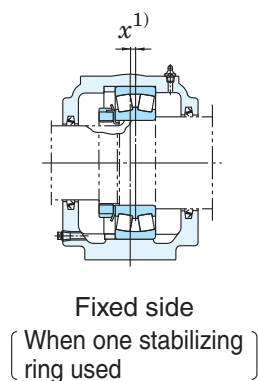

Stabilizing ring

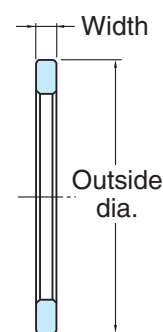

(Refer.) Housing mass (kg)	Grease nipple size	Drain plug size	Applicable bearing No.		Applicable stabilizing ring		Applicable oil seal No.	
			Self-aligning ball brg.	Spherical roller brg.	No.	Qty.	d_1 side	d_2 side
51	R 1/4	R 1/4	1322	—	SR240×20	2	MZ23	MZ28
			2322	22322RHR	SR240×10	1		
33	R 1/4	R 1/4	—	22224RHR 23224RH	SR215×14 SR215×10	2 1	MZ26	MZ30
63	R 1/4	R 1/4	—	22324RHR	SR260×10	1	MZ26	MZ30
45	R 1/4	R 1/4	—	22226RHR 23226RH	SR230×13 SR230×10	2 1	MZ28	MZ33
96	R 1/4	R 1/4	—	22326RHR	SR280×10	1	MZ28	MZ34
54	R 1/4	R 1/4	—	22228RHR 23228RH	SR250×15 SR250×10	2 1	MZ30	MZ35
117	R 1/4	R 1/4	—	22328R	SR300×10	1	MZ30	MZ36
60	R 1/4	R 1/4	—	22230RHR 23230RH	SR270×16.5 SR270×10	2 1	MZ33	MZ37
132	R 1/4	R 1/4	—	22330R	SR320×10	1	MZ33	MZ38
69	R 1/4	R 1/4	—	22232R 23232R	SR290×17 SR290×10	2 1	MZ34	MZ39
145	R 1/4	R 1/4	—	22332R	SR340×10	1	MZ34	MZ40

- [Remarks] 1) Large bore diameter types (concentric collar locking) are identified by B suffixed to housing numbers.
2) Housings shown below are equipped with eyebolts.
SSN224~SSN232, SSN318~SSN332

Plummer blocks

split type, large size

SD 5, 6

SD 33, 34

d_1 150 ~ 240 mm

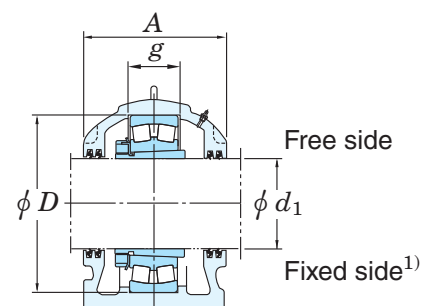
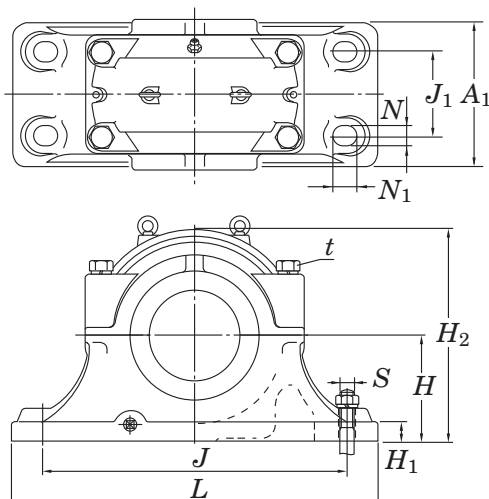

Shaft dia. (mm) d_1	Dimensions (mm)													Bolt size S	Housing No.
	D	H	J	J_1	L	A	A_1	H_1	H_2	N	N_1	g	t Bolt size		
150	260	160	450	110	540	230	200	50	315	36	46	77	M24	M30	SD3334
	310	180	510	140	620	270	250	60	360	36	46	96	M24	M30	SD534
	360	210	610	170	740	300	290	65	420	36	46	130	M30	M30	SD634
160	280	170	470	120	560	250	220	50	335	36	46	84	M24	M30	SD3336
	320	190	540	150	650	280	260	60	380	36	46	96	M24	M30	SD536
	380	225	640	180	780	320	310	70	450	43	59	136	M30	M36	SD636
170	290	170	470	120	560	250	220	50	340	36	46	85	M24	M30	SD3338
	340	200	570	160	700	290	280	65	400	36	46	102	M30	M30	SD538
	400	240	680	190	820	330	320	70	475	43	59	142	M30	M36	SD638
180	310	180	510	140	620	270	250	60	360	36	46	92	M24	M30	SD3340
	340	200	570	160	700	310	280	65	400	36	46	122	M30	M30	SD440
	360	210	610	170	740	300	290	65	420	36	46	108	M30	M30	SD540
	420	250	710	200	860	350	340	85	500	43	59	148	M36	M36	SD640
200	340	200	570	160	700	290	280	65	400	36	46	100	M30	M30	SD3344
	370	225	640	180	780	320	310	70	445	43	59	130	M30	M36	SD444
	400	240	680	190	820	330	320	70	475	43	59	118	M30	M36	SD544
	460	280	770	210	920	360	350	85	550	43	59	155	M36	M36	SD644
220	360	210	610	170	740	300	290	65	420	36	46	102	M30	M30	SD3348
	400	240	680	190	820	330	320	70	475	43	59	138	M30	M36	SD448
	440	260	740	200	880	340	330	85	515	43	59	130	M36	M36	SD548
	500	300	830	230	990	390	380	100	590	50	67	165	M36	M42	SD648
240	400	240	680	190	820	340	320	70	475	43	59	114	M30	M36	SD3352
	440	260	740	200	880	360	350	85	515	43	59	154	M36	M36	SD452
	480	280	790	210	940	370	360	85	560	43	59	140	M36	M36	SD552
	540	325	890	250	1 060	410	400	100	640	50	67	175	M36	M42	SD652

[Note] 1) Since bearings are designed to be locked by housing, stabilizing rings are unnecessary.

	(Refer.) Housing mass (kg)	Grease nipple size	Drain plug size	Applicable bearing No.	Applicable adapter ass'y No.	Applicable oil seal No. MZ
	70 105 165	R 3/8 R 3/8 R 3/8	R 3/8 R 3/8 R 3/8	23034RHK 22234RK 22334RK	H3034 H3134 H2334	MZ34 MZ34 MZ34
	80 120 200	R 3/8 R 3/8 R 3/8	R 3/8 R 3/8 R 3/8	23036RHK 22236RK 22336RK	H3036 H3136 H2336	MZ36 MZ36 MZ36
	90 145 220	R 3/8 R 3/8 R 3/8	R 3/8 R 3/8 R 3/8	23038RK 22238RK 22338RK	H3038 H3138 H2338	MZ38 MZ38 MZ38
	100 135 170 250	R 3/8 R 3/8 R 3/8 R 3/8	R 3/8 R 3/8 R 3/8 R 1/2	23040RK 23140RK 22240RK 22340RK	H3040 H3140 H3140 H2340	MZ40 MZ40 MZ40 MZ40
	130 185 220 320	R 3/8 R 3/8 R 3/8 R 3/8	R 3/8 R 3/8 R 3/8 R 1/2	23044RK 23144RK 22244RK 22344RK	H3044 H3144 H3144 H2344	MZ44 MZ44 MZ44 MZ44
	160 210 260 415	R 3/8 R 3/8 R 3/8 R 3/8	R 3/8 R 3/8 R 1/2 R 1/2	23048RK 23148RK 22248RK 22348RK	H3048 H3148 H3148 H2348	MZ48 MZ48 MZ48 MZ48
	215 245 325 490	R 3/8 R 3/8 R 3/8 R 3/8	R 3/8 R 1/2 R 1/2 R 3/4	23052RK 23152RK 22252RK 22352RK	H3052 H3152 H3152 H2352	MZ52 MZ52 MZ52 MZ52

[Remark] The structure of certain housings may differ from those shown in the figures.

Plummer blocks

split type, large size

SD 5, 6

SD 33, 34

d_1 260 ~ 360 mm

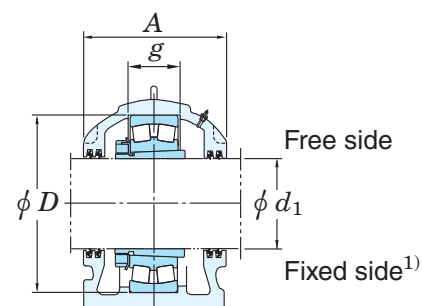
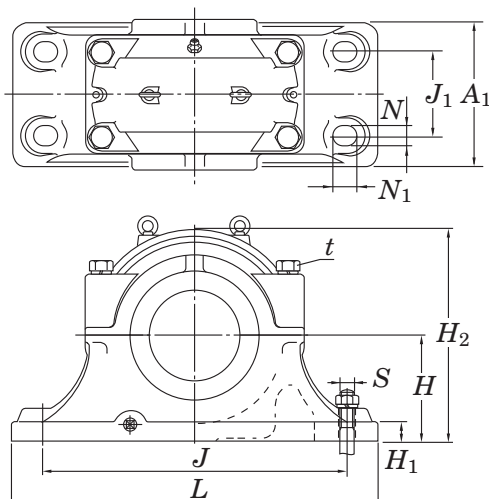

Shaft dia. (mm)	Dimensions (mm)													Bolt size S	Housing No.
	d_1	D	H	J	J_1	L	A	A_1	H_1	H_2	N	N_1	g		
260	420	250	710	200	860	350	340	85	500	43	59	116	M36	M36	SD3356
	460	280	770	210	920	360	350	85	550	43	59	156	M36	M36	SD3456
	500	300	830	230	990	390	380	100	590	50	67	140	M36	M42	SD556
	580	355	930	270	1 110	440	430	110	690	57	77	185	M42	M48	SD656
280	460	280	770	210	920	360	350	85	550	43	59	128	M36	M36	SD3360
	500	300	830	230	990	390	380	100	590	50	67	170	M36	M42	SD3460
	540	325	890	250	1 060	410	400	100	640	50	67	150	M36	M42	SD560
300	480	280	790	210	940	380	360	85	560	43	59	131	M36	M36	SD3364
	540	325	890	250	1 060	430	400	100	640	50	67	186	M36	M42	SD3464
	580	355	930	270	1 110	440	430	110	690	57	77	160	M42	M48	SD564
320	520	310	860	230	1 020	400	370	100	615	50	67	143	M36	M42	SD3368
	580	355	930	270	1 110	470	450	110	690	57	77	200	M42	M48	SD3468
340	540	325	890	250	1 060	410	390	100	640	50	67	144	M36	M42	SD3372
360	560	340	900	260	1 080	410	390	100	665	50	67	145	M36	M42	SD3376

[Note] 1) Since bearings are designed to be locked by housing, stabilizing rings are unnecessary.

	(Refer.) Housing mass (kg)	Grease nipple size	Drain plug size	Applicable bearing No.	Applicable adapter ass'y No.	Applicable oil seal No. MZ
	245	R $\frac{3}{8}$	R $\frac{1}{2}$	23056RK	H3056	MZ56
	320	R $\frac{3}{8}$	R $\frac{1}{2}$	23156RK	H3156	MZ56
	395	R $\frac{3}{8}$	R $\frac{1}{2}$	22256RK	H3156	MZ56
	615	R $\frac{3}{8}$	R $\frac{3}{4}$	22356RK	H2356	MZ56
	305	R $\frac{3}{8}$	R $\frac{1}{2}$	23060RK	H3060	MZ60
	400	R $\frac{3}{8}$	R $\frac{1}{2}$	23160RK	H3160	MZ60
	490	R $\frac{3}{8}$	R $\frac{3}{4}$	22260RK	H3160	MZ60
	325	R $\frac{3}{8}$	R $\frac{1}{2}$	23064RK	H3064	MZ64
	480	R $\frac{3}{8}$	R $\frac{3}{4}$	23164RK	H3164	MZ64
	600	R $\frac{3}{8}$	R $\frac{3}{4}$	22264RK	H3164	MZ64
	420	R $\frac{3}{8}$	R $\frac{3}{4}$	23068RK	H3068	MZ68
	645	R $\frac{3}{8}$	R $\frac{3}{4}$	23168RK	H3168	MZ68
	470	R $\frac{3}{8}$	R $\frac{3}{4}$	23072RK	H3072	MZ72
	485	R $\frac{3}{8}$	R $\frac{3}{4}$	23076RK	H3076	MZ76

[Remark] The structure of certain housings may differ from those shown in the figures.

Plummer blocks

split type, large size

SD 31

d_1 150 ~ 300 mm

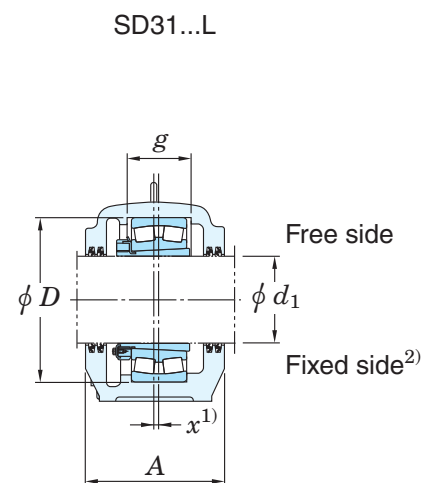
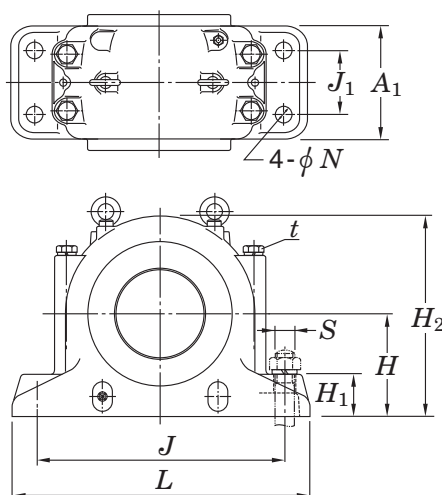

Shaft dia. (mm) d_1	Dimensions (mm)															Housing No.	
	D	H	J	J_1	L	A	A_1	A_2	A_3	A_4	H_1	H_2	N	g	t Bolt size		x^1
150	280	170	430	100	510	230	180	240	300	120	70	335	28	108	M20	14	SD3134L
160	300	180	450	110	530	240	190	250	310	125	75	355	28	116	M20	15	SD3136L
170	320	190	480	120	560	260	210	270	330	135	80	375	28	124	M24	10	SD3138L
180	340	210	510	130	610	280	230	290	350	145	85	410	35	132	M24	10	SD3140L
200	370	220	540	140	640	290	240	300	360	152	90	435	35	140	M24	12	SD3144L
220	400	240	600	150	700	310	260	320	380	162	95	475	35	148	M30	12	SD3148L
240	440	260	650	160	770	320	280	330	396	170	100	515	42	164	M30	13	SD3152L
260	460	280	670	160	790	320	280	330	396	170	105	550	42	166	M30	16	SD3156L
280	500	300	710	190	830	350	310	360	420	193	110	590	42	180	M30	22	SD3160L
300	540	320	750	200	880	370	330	380	440	203	115	630	42	196	M30	23	SD3164L

- [Notes] 1) Dimension x shows the shear between center of bearing and housing.
 2) Stabilizing rings are mounted to the fixed side of the SD 31...TS and SD 31 ...TAC series (both sides of bearings).
 SD31...L series are locked by housings.

SD31...TS
(With labyrinth seals)

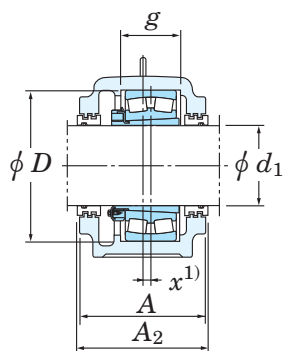

SD31...TAC
(With taconite seal(s))

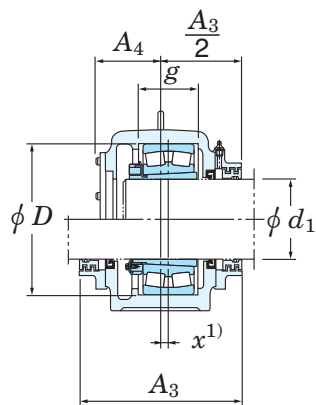

Stabilizing ring

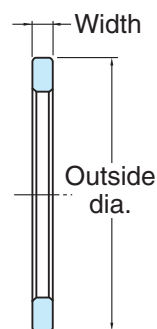

	Bolt size <i>S</i>	(Refer.) Housing mass (kg)	Grease nipple size	Drain plug size	Applicable bearing No.	Applicable adapter ass'y No.	Applicable stabilizing ring ²⁾	
							No. Outside dia.×Width	Qty.
	M24	65	R 3/8	R 3/8	23134RHK	H3134	SR280×10	2
	M24	75	R 3/8	R 3/8	23136RK	H3136	SR300×10	2
	M24	95	R 3/8	R 3/8	23138RK	H3138	SR320×10	2
	M30	120	R 3/8	R 3/8	23140RK	H3140	SR340×10	2
	M30	140	R 3/8	R 3/8	23144RK	H3144	SR370×10	2
	M30	180	R 3/8	R 3/8	23148RK	H3148	SR400×10	2
	M36	220	R 3/8	R 1/2	23152RK	H3152	SR440×10	2
	M36	250	R 3/8	R 1/2	23156RK	H3156	SR460×10	2
	M36	300	R 3/8	R 1/2	23160RK	H3160	SR500×10	2
	M36	340	R 3/8	R 3/4	23164RK	H3164	SR540×10	2

[Remark] Use of labyrinth or taconite seals are indicated by TS or TAC suffixed to housing numbers.

Plummer blocks one-piece type

V 5, 6

d_1 30 ~ 65 mm

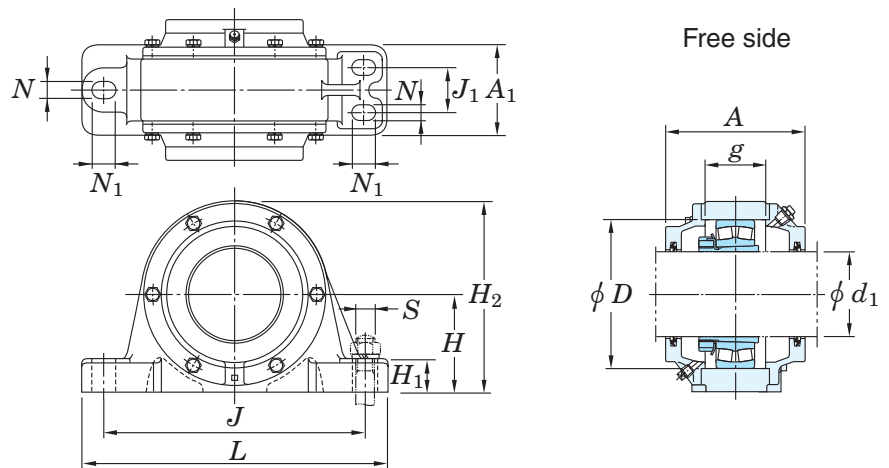

Shaft dia. (mm) d_1	Dimensions (mm)													Bolt size S		Housing No.
	D	H	J	J_1	L	A	A_1	H_1	H_2	N	N_1	g	(Two)	(Four)		
30	80	60	170	—	205	95	60	25	118	16	20	37	M14	—	V607	
	90	67	170	—	205	100	60	25	128	16	20	39	M14	—	V508	
40	85	63	170	—	205	98	60	25	125	16	20	39	M14	—	V608	
	100	71	210	—	255	106	70	28	140	16	23	42	M14	—	V509	
45	90	67	170	—	205	100	60	25	128	16	20	39	M14	—	V609	
	110	80	210	—	255	112	70	30	155	21	25	46	M18	—	V510	
50	100	71	210	—	255	106	70	28	140	16	23	42	M14	—	V610	
	120	85	230	—	275	118	80	30	165	21	25	49	M18	—	V511	
55	110	80	210	—	255	112	70	30	155	21	25	46	M18	—	V611	
	130	90	230	—	280	118	80	30	175	21	25	50	M18	—	V512	
60	120	85	230	—	275	118	80	30	165	21	25	49	M18	—	V612	
	125	90	230	—	280	118	80	30	175	21	25	50	M18	—	V513	
	140	100	260	—	315	136	90	32	195	25	30	56	M22	—	V514	
	150	100	260	—	315	140	90	32	195	25	30	56	M22	—	V613	
65	130	90	230	—	280	118	80	30	175	21	25	50	M18	—	V614	
	160	112	290	—	345	150	100	35	224	25	30	62	M22	—	V515	

[Note] 1) Dimension x shows the shear between center of bearing and housing when one stabilizing ring is used. The value is 1/2 the width dimension of stabilizing ring.
When mounting two stabilizing rings, x becomes equal to 0, since they are mounted to each side of bearing.

Fixed side
(When one stabilizing ring used)

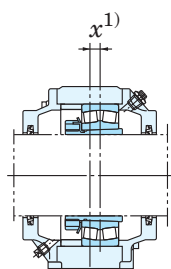

Stabilizing ring

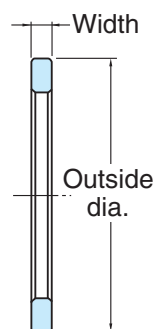

	(Refer.) Housing mass (kg)	Grease nipple size	Drain plug size	Housing No.	Applicable bearing No.		Applicable adapter ass'y No.	Applicable stabilizing ring		Applicable oil seal No. MZ
					Self-aligning ball brg.	Spherical roller brg.		No. Outside dia.×Width	Qty.	
	4.8	R 1/8	R 1/8	V080	1307K 2307K	—	H307X H2307X	SR80×8 SR80×6	2 1	MZ07
	4.4	R 1/8	R 1/8	V080	1208K 2208K	— 22208RHRK	H208X H308X	SR80×9.5 SR80×7	2 2	MZ08
	5.1	R 1/8	R 1/8	V090	1308K 2308K	21308RHK 22308RHRK	H308X H2308X	SR90×8 SR90×6	2 1	MZ08
	4.6	R 1/8	R 1/8	V085	1209K 2209K	— 22209RHRK	H209X H309X	SR85×10 SR85×8	2 2	MZ09
	6.6	R 1/8	R 1/8	V100	1309K 2309K	21309RHK 22309RHRK	H309X H2309X	SR100×8.5 SR100×6	2 1	MZ09
	4.7	R 1/8	R 1/8	V090	1210K 2210K	— 22210RHRK	H210X H310X	SR90×9.5 SR90×8	2 2	MZ10
	8.3	R 1/8	R 1/8	V110	1310K 2310K	21310RHK 22310RHRK	H310X H2310X	SR110×9.5 SR110×6	2 1	MZ10
	6.2	R 1/8	R 1/8	V100	1211K 2211K	— 22211RHRK	H211X H311X	SR100×10.5 SR100×8.5	2 2	MZ11
	10	R 1/8	R 1/8	V120	1311K 2311K	21311RHK 22311RHRK	H311X H2311X	SR120×10 SR120×6	2 1	MZ11
	7.6	R 1/8	R 1/8	V110	1212K 2212K	— 22212RHRK	H212X H312X	SR110×12 SR110×9	2 2	MZ12
	11	R 1/8	R 1/8	V130	1312K 2312K	21312RHK 22312RHRK	H312X H2312X	SR130×9.5 SR130×4	2 1	MZ12
	9.9	R 1/8	R 1/8	V120	1213K 2213K	— 22213RHRK	H213X H313X	SR120×13 SR120×9	2 2	MZ13
	10	R 1/8	R 1/8	V125	—	22214RHRK	H314X	SR125×9.5	2	MZ13
	17	R 1/8	R 1/8	V140	1313K 2313K	21313RHK 22313RHRK	H313X H2313X	SR140×11.5 SR140×8	2 1	MZ13
	16	R 1/8	R 1/8	V150	—	21314RHK 22314RHRK	H314X H2314X	SR150×10.5 SR150×5	2 1	MZ13
	10	R 1/8	R 1/8	V130	1215K 2215K	— 22215RHRK	H215X H315X	SR130×12.5 SR130×9.5	2 2	MZ15
	23	R 1/8	R 1/8	V160	1315K 2315K	21315RHK 22315RHRK	H315X H2315X	SR160×12.5 SR160×7	2 1	MZ15

[Remark] Housings shown below are equipped with eyebolts.
V180~V340 (V520~V538 and V617~V632)

Plummer blocks

one-piece type

V 5, 6

d_1 70 ~ (125) mm

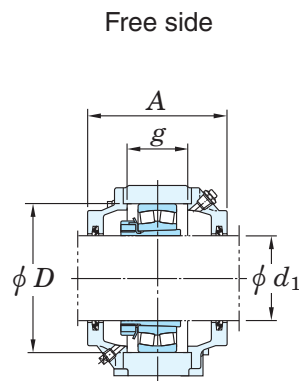
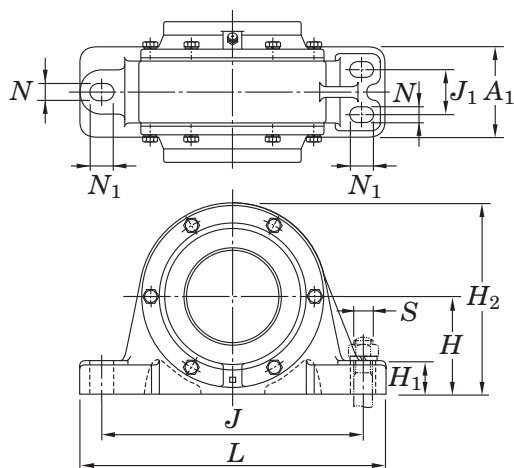

Shaft dia. (mm) d_1	Dimensions (mm)													Bolt size S		Housing No.
	D	H	J	J_1	L	A	A_1	H_1	H_2	N	N_1	g	(Two)	(Four)		
70	140	100	260	—	315	136	90	32	195	25	30	56	M22	—	V516	
	170	112	290	—	345	165	100	35	224	25	30	62	M22	—	V616	
75	150	100	260	—	315	140	90	32	195	25	30	56	M22	—	V517	
	180	125	320	56	380	170	110	40	243	23	32	70	—	M20	V617	
80	160	112	290	—	345	150	100	35	224	25	30	62	M22	—	V518	
	190	125	320	56	380	170	110	40	243	23	32	70	—	M20	V618	
85	170	112	290	—	345	165	100	35	224	25	30	62	M22	—	V519	
	200	132	350	60	410	190	120	45	265	23	32	82	—	M20	V619	
90	180	125	320	56	380	170	110	40	243	23	32	70	—	M20	V520	
	215	140	350	60	410	190	120	45	280	23	32	82	—	M20	V620	
100	200	132	350	60	410	190	120	45	265	23	32	82	—	M20	V522	
	240	160	390	80	470	218	150	50	315	23	32	96	—	M20	V622	
110	215	140	350	60	410	190	120	45	280	23	32	82	—	M20	V524	
	260	170	450	92	540	236	160	60	335	29	42	103	—	M24	V624	
115	230	150	380	65	450	200	130	50	300	23	32	86	—	M20	V526	
	280	180	470	92	560	243	160	60	355	29	42	103	—	M24	V626	
125	250	160	420	80	500	218	150	50	315	23	32	94	—	M20	V528	

[Note] 1) Dimension x shows the shear between center of bearing and housing when one stabilizing ring is used. The value is 1/2 the width dimension of stabilizing ring.
When mounting two stabilizing rings, x becomes equal to 0, since they are mounted to each side of bearing.

Fixed side
(When one stabilizing ring used)

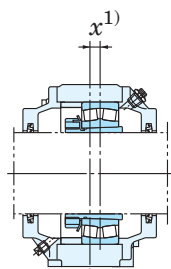

Stabilizing ring

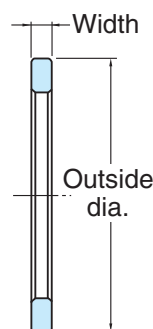

	(Refer.) Housing mass (kg)	Grease nipple size	Drain plug size	Housing No.	Applicable bearing No.		Applicable adapter ass'y No.	Applicable stabilizing ring		Applicable oil seal No. MZ
					Self-aligning ball brg.	Spherical roller brg.		No. Outside dia.xWidth	Qty.	
	16	R 1/8	R 1/8	V140	1216K 2216K	— 22216RHRK	H216X H316X	SR140×15 SR140×11.5	2 2	MZ16
	22	R 1/8	R 1/8	V170	1316K 2316K	21316RHK 22316RHRK	H316X H2316X	SR170×11.5 SR170×4	2 1	MZ16
	15	R 1/8	R 1/8	V150	1217K 2217K	— 22217RHRK	H217X H317X	SR150×14 SR150×10	2 2	MZ17
	28	R 1/4	R 1/4	V180	1317K 2317K	21317RHK 22317RHRK	H317X H2317X	SR180×14.5 SR180×10	2 1	MZ17
	22	R 1/8	R 1/8	V160	1218K 2218K —	— 22218RHRK 23218RHK	H218X H318X H2318X	SR160×16 SR160×11 SR160×9.6	2 2 1	MZ18
	27	R 1/4	R 1/4	V190	1318K 2318K	21318RHK 22318RHRK	H318X H2318X	SR190×13.5 SR190×6	2 1	MZ18
	21	R 1/8	R 1/8	V170	1219K 2219K	— 22219RHRK	H219X H319X	SR170×11 SR170×9.5	2 2	MZ19
	37	R 1/4	R 1/4	V200	1319K 2319K	21319RHK 22319RHRK	H319X H2319X	SR200×18.5 SR200×15	2 1	MZ19
	27	R 1/4	R 1/4	V180	1220K 2220K —	— 22220RHRK 23220RHK	H220X H320X H2320X	SR180×18 SR180×12 SR180×9.7	2 2 1	MZ20
	40	R 1/4	R 1/4	V215	1320K 2320K	21320RHK 22320RHRK	H320X H2320X	SR215×17.5 SR215×9	2 1	MZ20
	36	R 1/4	R 1/4	V200	1222K 2222K —	— 22222RHRK 23222RHK	H222X H322X H2322X	SR200×22 SR200×14.5 SR200×12.2	2 2 1	MZ22
	56	R 1/4	R 1/4	V240	1322K 2322K	21322RHK 22322RHRK	H322X H2322X	SR240×23 SR240×16	2 1	MZ22
	39	R 1/4	R 1/4	V215	—	22224RHRK 23224RHK	H3124 H2324	SR215×12 SR215×6	2 1	MZ24
	71	R 1/4	R 1/4	V260	—	22324RHRK	H2324	SR260×17	1	MZ24
	48	R 1/4	R 1/4	V230	—	22226RHRK 23226RHK	H3126 H2326	SR230×11 SR230×6	2 1	MZ26
	82	R 1/4	R 1/4	V280	—	22326RHRK	H2326	SR280×15	1	MZ26
	54	R 1/4	R 1/4	V250	—	22228RHRK 23228RHK	H3128 H2328	SR250×13 SR250×6	2 1	MZ28

[Remark] Housings shown below are equipped with eyebolts.
V180~V340 (V520~V538 and V617~V632)

Plummer blocks

one-piece type

V 5, 6

d_1 (125) ~ 170 mm

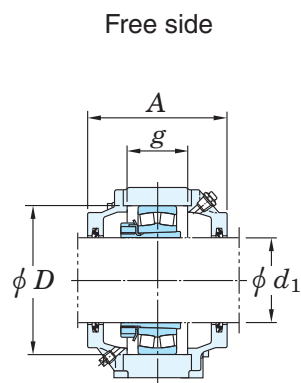
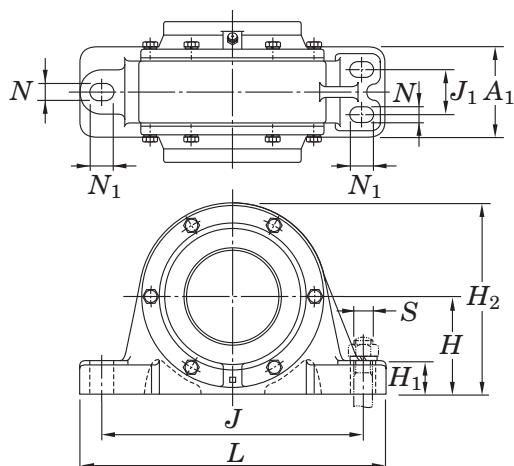

Shaft dia. (mm) d_1	Dimensions (mm)												Bolt size S		Housing No.	
	D	H	J	J_1	L	A	A_1	H_1	H_2	N	N_1	g	(Two)	(Four)		
125	300	190	520	92	610	250	170	65	375	29	50	113	—	M24	V628	
135	270	170	450	92	540	236	160	60	335	29	42	103	—	M24	V530	
	320	200	560	92	660	258	180	65	405	29	50	122	—	M24	V630	
140	290	190	470	92	560	250	170	60	375	29	50	113	—	M24	V532	
	340	212	580	104	680	300	190	65	425	33	54	130	—	M27	V632	
150	310	200	560	92	660	258	180	65	405	29	50	122	—	M24	V534	
160	320	200	560	92	660	258	180	65	405	29	50	122	—	M24	V536	
170	340	212	580	104	680	300	190	65	425	33	54	130	—	M27	V538	

[Note] 1) Dimension x shows the shear between center of bearing and housing when one stabilizing ring is used. The value is 1/2 the width dimension of stabilizing ring.
When mounting two stabilizing rings, x becomes equal to 0, since they are mounted to each side of bearing.

Fixed side
(When one stabilizing ring used)

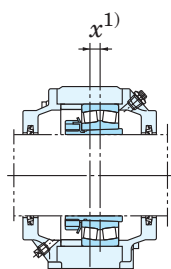

Stabilizing ring

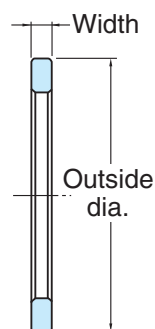

	(Refer.) Housing mass (kg)	Grease nipple size	Drain plug size	Housing No.	Applicable bearing No.		Applicable adapter ass'y No.	Applicable stabilizing ring		Applicable oil seal No. MZ
					Self-aligning ball brg.	Spherical roller brg.		No. Outside dia.×Width	Qty.	
	101	R 1/4	R 1/4	V300	—	22328RK	H2328	SR300×11	1	MZ28
	64	R 1/4	R 1/4	V270	—	22230RHRK 23230RHK	H3130 H2330	SR270×15 SR270×7	2 1	MZ30
	129	R 1/4	R 1/4	V320	—	22330RK	H2330	SR320×14	1	MZ30
	92	R 1/4	R 1/4	V290	—	22232RK 23232RK	H3132 H2332	SR290×16.5 SR290×9	2 1	MZ32
	149	R 1/4	R 1/4	V340	—	22332RK	H2332	SR340×16	1	MZ32
	110	R 1/4	R 1/4	V310	—	22234RK 23234RK	H3134 H2334	SR310×18 SR310×12	2 1	MZ34
	110	R 1/4	R 1/4	V320	—	22236RK 23236RK	H3136 H2336	SR320×18 SR320×10	2 1	MZ36
	130	R 1/4	R 1/4	V340	—	22238RK 23238RK	H3138 H2338	SR340×19 SR340×10	2 1	MZ38

[Remark] Housings shown below are equipped with eyebolts.
V180~V340 (V520~V538 and V617~V632)

KOYO



Ceramic&Exsev bearing series

More and more bearings are being used in extreme special environments, such as in a vacuum, or in a clean, corrosive, or heated place. In some cases bearings are required to be insulated or antimagnetic.

Applications of bearings in such environments are increasing in the field of state-of-the-art technology, e.g. vacuum equipment, aerospace equipment and semi-conductor production facilities. Bearings made of conventional materials and lubricants can hardly meet these new needs.

JTEKT has succeeded in developing a series of bearings for use in extreme special environments, having started from the study of the very basics of materials and testing of their performance under various severe conditions.

JTEKT has standardized the following bearings as the "Koyo **EXSEV** bearing series".

- Exsev bearings for use in a clean environment
Designed for use in a vacuum.
The friction surface of the bearing interior is coated with solid lubricant (or soft metal). Bearings pre-lubricated with special grease are also available.
- Exsev bearings for use in a vacuum environment
Produce insignificant contamination, provided with rolling elements and a cage made of self-lubricating materials. Optimal for use in environments which need to be clean.
- Ceramic bearings
Ceramic rings and rolling elements (silicon nitride Si_3N_4) ensure excellent performance in various extreme special environments.
- For details, refer to JTEKT separate catalog "Ceramic bearings and **EXSEV** bearings for extreme special environments" (CAT. NO. B2004E).

Exsev bearings for use in a vacuum environment

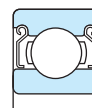

Bore diameter 4 – 40 mm

Exsev bearings for use in a clean environment

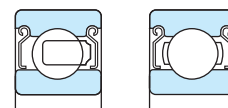

Bore diameter 4 – 40 mm

Ceramic bearings

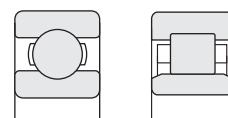

Bore diameter 4 – 120 mm

Linear ball bearings for vacuum

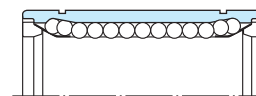

Ball complement
bore diameter 3 – 40 mm

The chart below summarizes the EXSEV bearing series and the conditions in which each operates successfully.

Materials and lubricants which are resistant to certain special conditions are listed in Tables 1 and 2.

Major Koyo EXSEV bearing series made of these materials and lubricants are listed in Table 3.

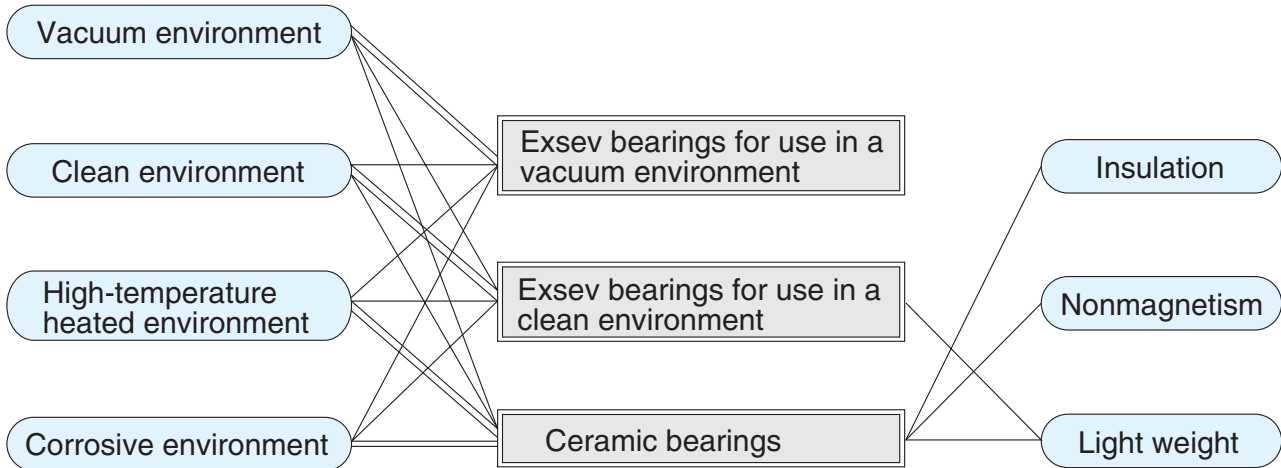

Table 1 EXSEV bearing materials

Bearing material	Component				Operating temperature range °C	Vacuum resistance (room temperature) Pa	Density g/cm ³	Young's ¹⁾ modulus GPa	Coefficient ²⁾ of linear thermal expansion ×10 ⁻⁶ / °C
	Bearing ring	Rolling element	Cage	Shield					
Martensitic stainless steel	<input type="checkbox"/>	<input type="checkbox"/>			- 250 to + 400	Atmospheric pressure (10 ⁵) to 10 ⁻⁸	7.7	208	10.5
Precipitation hardening stainless steel	<input type="checkbox"/>	<input type="checkbox"/>			- 250 to + 400	Atmospheric pressure to 10 ⁻⁸	7.8	196	11.0
High speed tool steel	<input type="checkbox"/>	<input type="checkbox"/>			- 250 to + 550	Atmospheric pressure to 10 ⁻⁸	8.5	207	12.0
Ceramics (Si ₃ N ₄)	<input type="checkbox"/>	<input type="checkbox"/>			- 270 to + 800	Atmospheric pressure to 10 ⁻⁸	3.2	320	3.2
Graphite (GF)			<input type="checkbox"/>		+ 500 max.	-	2.15	-	5.5
Reinforced fluorocarbon resin (FA)			<input type="checkbox"/>		- 100 to + 200	Atmospheric pressure to 10 ⁻⁶	1.9	-	-
Reinforced fluorocarbon resin (PT)			<input type="checkbox"/>		- 100 to + 200	Atmospheric pressure to 10 ⁻⁴	2.15	-	-
Reinforced PEEK resin (PN)			<input type="checkbox"/>		- 100 to + 300	Atmospheric pressure to 10 ⁻⁶	1.54	-	-
Austenitic stainless steel			<input type="checkbox"/>	<input type="checkbox"/>	- 200 to + 300	Atmospheric pressure to 10 ⁻⁸	8.0	193	16.3
(Ref.) High carbon chromium bearing steel	<input type="checkbox"/>	<input type="checkbox"/>			- 200 to + 120	Atmospheric pressure to 10 ⁻⁸	7.8	208	12.5

[Notes] 1) A larger Young's modulus indicates higher rigidity.

2) A smaller coefficient of linear thermal expansion indicates a greater dimensional stability under heating.

Table 2 EXSEV bearing lubricants

Lubricant		Operating temperature range °C	Vacuum resistance(room temperature) Pa	Steam pressure at high temperature Pa	Remarks
Vacuum grease		- 30 to + 200	Atmospheric pressure(10^5) to 10^{-5}	-	Not to be used when grease affects operating environment.
Solid lubricant	Polytetrafluoroethylene resin (PTFE)	- 100 to + 200	Atmospheric pressure to 10^{-5}	-	Highly resistant to chemicals and highly insulating. Suitable when the environment repeats alternation between the atmosphere and a vacuum.
	Molybdenum disulfide (MoS_2)	- 100 to + 300	Atmospheric pressure to 10^{-5}	-	Friction torque is low even in a vacuum. Not suitable for use in air at high temperature.
	Lead ¹⁾ (Pb)	- 200 to + 300	10^{-3} to 10^{-10}	10^{-6} (300°C)	Low friction torque. Not suitable for use in air.
	Silver ¹⁾ (Ag)	- 200 to + 600	10^{-3} to 10^{-10}	10^{-5} (550°C)	Not suitable for use in air or in corrosive gas.

[Note] 1) Rolling elements or bearing rings are coated using the special ion plating method JTEKT developed.

[Remark] The lubricants in the table above are usually applied to bearings for use in a vacuum. The most suitable one should be selected in consideration of the vacuum condition, temperature, and whether reactive gas or inert gas exists.

○ Good △ Fair × No good

	Self-lubrication	Insulation	Nonmagnetism	Corrosion resistance										Used to produce :		
				Water	Sea water	Alkalescent liquid	Weak acid liquid	Strong alkali liquid	Strong acid liquid		Molten metal		Hydrogen fluoride	Vacuum bearings	Ceramic bearings	Clean bearings
									Sulfuric acid	Hydrochloric acid	Al Zn	Fe				
	×	×	×	△	×	○	×	×	×	×	×	×	×	□	□	□
	×	×	×	○	△	○	○	○	○	×	×	×	×		□	□
	×	×	×	△	×	○	×	×	×	×	×	×	×	□	□	
	×	○	○	○	○	○	○	△	○	○	○	×	×		□	
	○	×	○	○	○	○	○	○	○	○	○	○	○		□	
	○	○	○	○	○	○	○	○	○	○	×	×	○		□	□
	○	○	○	○	○	○	○	○	○	○	×	×	○		□	
	×	×	○	○	○	○	△	×	×	×	×	×	×	□	□	□
	×	×	×	×	×	×	×	×	×	×	×	×	×		—	

Table 3 Koyo EXSEV bearing series models and types

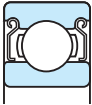
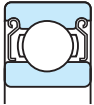
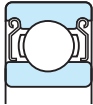
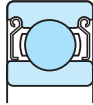
		Exsev bearings for use in a vacuum environment				
Characteristics(selective points)	Vacuum resistance ¹⁾	Repeated alternation between atmospheric pressure and medium vacuum environments	Repeated alternation between atmospheric pressure and high vacuum environments		From high vacuum to ultra-high vacuum	
	Operating temperature range, °C	- 30 to + 200	- 100 to + 300	- 100 to + 350	- 200 to + 350	
	Cleanness	(class 100 ⁵⁾)	-	-	-	
	Corrosion resistance ²⁾	○	○	○	-	
	Running friction torque	-	Low torque	Low torque	-	
	Others	-	-	-	Unstable for use with oxygen or corrosive gas	
Bearing types		DL bearing	MO bearing	WS bearing	MG bearing	
						
		SV...ST	SE...STMSA7	SE...STWS	SE...STMG3	
Materials	Inner ring and outer ring	Martensitic stainless steel				
	Rolling elements (balls or rollers)					
	Cage	Austenitic stainless steel		Tungsten disulfide (WS)	Austenitic stainless steel	
Lubricant	Vacuum grease	Cage coated with molybdenum disulfide(MoS ₂)	Self-lubrication ⁶⁾	Balls coated with ³⁾ silver(Ag)		
Applications	Vacuum pump, general vacuum equipment	P-CVD equipment for manufacture of semiconductors and electronic parts, sputtering equipment		Electron beam epitaxial equipment		

[Notes] 1) Vacuum (pressure) is generally graded as follows :

- Low vacuum.....10⁵ - 10²Pa
- Medium vacuum.....10² - 10⁻¹Pa
- High vacuum.....10⁻¹ - 10⁻⁵Pa
- Ultra-high vacuum.....10⁻⁵Pa or less
- Extremely high vacuum.....10⁻⁸Pa or less (Atmospheric pressure ≒ 10⁵Pa)

2) The corrosion resistance column shows general evaluations.

Marks "◎" and "○", respectively, denote "excellent", "good", and "fair".

Refer to Table 1 for the corrosive materials concerned.

3) These soft metals are applied by the special ion plating method JTEKT developed, so that they feature excellent bonding strength, extending the service life of bearings.

4) When higher corrosion resistance, nonmagnetism and heat resistance are required, Full Ceramic Bearings should be used. Please consult with JTEKT for details.

Ceramics can also be used to produce many types of bearings, such as angular contact ball bearings and cylindrical roller bearings.

Exsev bearings for use in a clean environment			Ceramic bearings ⁴⁾				
Repeated alternation between atmospheric pressure and medium vacuum environments			Repeated alternation between atmospheric pressure and medium vacuum environments		atmospheric pressure		
- 30 to + 120	- 120 to + 200	+ 200 to + 260	- 100 to + 200		- 30 to + 120	+ 500 max.	
class 10 ⁵⁾			-	-	-	-	
○			◎	-	-	-	
Extremely low torque			-	-	-	-	
-	-	-	Corrosion resistant	nonmagnetism	Insulation	High temperature	
Clean pro PRA bearing	Clean pro bearing	High temperature clean pro bearing	Hybrid ceramic bearing	Hybrid ceramic bearing	Hybrid ceramic bearing	Hybrid ceramic bearing	
SE...STPRA	SE...STPR	SE...STPRB	3NC...MD4FA	3NC...YH4FA	3NC...FG	3NC...HT4GF	
Martensitic stainless steel			Precipitation hardening stainless steel	Non-magnetic stainless steel	High carbon chrome bearing steel	High speed tool steel	
Martensitic stainless steel			Ceramics				
Austenitic stainless steel			Fluorocarbon resin (FA)	Polyamide resin	Graphite (GF)		
Fluorocarbon-base polymeric coating			Self-lubrication ⁶⁾		Vacuum grease	Self-lubrication ⁶⁾	
Semiconductor manufacturing			Food or chemical manufacturing equipment	Vacuum equipment	Motors	Heat roll heat treatment furnaces	

5) These evaluations indicate the cleanness around the bearing, or in the equipment interior. Cleanness is largely dependent on the amount of dirt produced by operation of the bearing. The suffixed numbers refer to amounts of dirt, and the smaller the number is, the less dirt produced by the bearing.

[Ex.] Class 10.....there are less than 10 particles 0.5 μm or larger in diameter in a 1-cubic-foot space.(as specified in USA standards FED-STD-209D.)

6) Because the cage is made from self-lubricating material.

■ Life of EXSEV Bearings

EXSEV bearings, lubricated with a solid lubricant, are usually used under relatively light load conditions, such as 10% of their static load ratings or less.

These bearings can maintain stable performance as long as the solid lubricant is maintained. Once the lubricant wears out, metallic contact occurs, which increases rotational friction torque and shortens service life.

Service life depends on use conditions. At present, it is not possible to predict their service life under varied use conditions.

However, based on a variety of experiments and tests, JTEKT has established an experimental formulae to predict the lives of bearings. The formulae is described in the following subsections for reference only.

(1) Life of MG bearings consisting of silver-coated balls

The life of MG bearings (JTEKT serial number, SE...STMG3) can be predicted according to the following formula;

$$L_{vh} = b_1 \cdot b_2 \cdot b_3 (C_v/P)^q \times 16\,667/n \dots\dots\dots (1)$$

where,

- L_{vh} : 90% reliable life, h
- C_v : Basic dynamic load rating of vacuum-resistant ball bearings (1/13 of basic dynamic load rating of steel bearings of equal size), N
- P : Dynamic equivalent load, N
- q : Index, $q = 1$
- n : Rotational speed, min^{-1} , limited to $10 \leq n \leq 10\,000$
- b_1 : Rotational speed-dependant coefficient
 $b_1 = 1.5 \times 10^{-3}n + 1$
- b_2 : Material coefficient
 $b_2 = 1$ (for bearings ion-plated with silver by the special ion-plating process)
- b_3 : Coefficient for atmospheric pressure and temperature
 $b_3 = 1$ (for 10^{-3} Pa and room temperature)

(2) For bearings coated with PTFE or special polymeric fluoride

For those bearings coated with PTFE (MP7) or those coated with the special polymeric fluoride (PR), the following formula gives their mean life for reference only. (See Fig. 3.8.)

$$L_{av} = b_2 \cdot (C_e/P)^d \times 0.016667/n \dots\dots\dots (2)$$

where,

- L_{av} : Average life, h
- b_2 : Lubrication coefficient
6 for bearings coated with PTFE
42 for bearings coated with special polymeric fluoride
- C_e : 0.85 times the basic dynamic load rating of steel bearings of equal size, N
- P : Dynamic equivalent load, N
- d : Coefficient, $d = 3$
- n : Rotational speed, min^{-1}

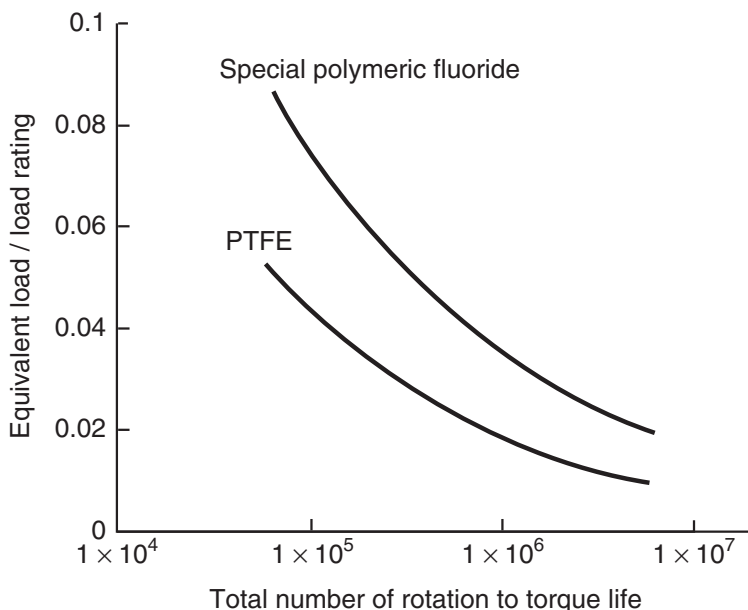

Fig. 1 Mean life of Coated Bearings

(3) Ceramic bearing service life

Ceramic bearings are used for a variety of purposes, and their specifications differ case by case. Therefore, there is no common system for estimating their service lives.

The estimation of full ceramic bearing service life is especially difficult at present for theoretical reasons, and requires further study.

JTEKT estimates the full ceramic bearing service life on a case by case basis according to the customer request, based on experience and experimental data.

For hybrid ceramic bearings, in many cases the conventional equation (2) below based on rolling contact fatigue is used to estimate service life, where grease or oil can be used for lubrication and, at the same time, bearings are required to be insulating and antimagnetic, or to be highly rigid and have excellent high-speed performance.

This equation is called the corrected rated life estimation equation. (refer to p. A 26.)

$$L_{na} = a_1 a_2 a_3 L_{10} = a_1 a_2 a_3 (C/P)^p \dots\dots\dots (3)$$

- In an environment where a lubricating film is formed properly, the bearing characteristic coefficient a_2 is expected to be equivalent to or larger than that of conventional steel bearings. However, given current conditions, coefficient a_2 is counted as : $a_2 = 1$. Basic dynamic load rating C is treated as being equivalent to that of steel bearings of the same type and size.
- When a satisfactory oil film is formed, the operating condition coefficient a_3 is counted as : $a_3 > 1$.

EXSEV bearing series

for use in a vacuum environment

d 4 ~ 17 mm

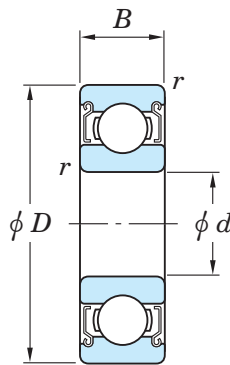

Boundary dimensions (mm)				Bearing No.	
d	D	B	$r^{1)}$ min.	Atmospheric pressure to 10^{-5} Pa	
				With vacuum grease filled	MoS ₂ coating (cage)
4	10	4	0.1(0.15)	SVWML 4010 ZZST	SEWML 4010 ZZSTMSA7
	12	4	0.2	SV 604 ZZST	SE 604 ZZSTMSA7
	13	5	0.2	SV 624 ZZST	SE 624 ZZSTMSA7
5	14	5	0.2	SV 605 ZZST	SE 605 ZZSTMSA7
	16	5	0.3	SV 625 ZZST	SE 625 ZZSTMSA7
6	10	3	0.08(0.1)	SVWML 6010 ZZST	SEWML 6010 ZZSTMSA7
	12	4	0.1(0.15)	SVWML 6012 ZZST	SEWML 6012 ZZSTMSA7
	13	5	0.15	SV 686 ZZST	SE 686 ZZSTMSA7
	17	6	0.3	SV 606 ZZST	SE 606 ZZSTMSA7
	19	6	0.3	SV 626 ZZST	SE 626 ZZSTMSA7
7	19	6	0.3	SV 607 ZZST	SE 607 ZZSTMSA7
	22	7	0.3	SV 627 ZZST	SE 627 ZZSTMSA7
8	22	7	0.3	SV 608 ZZST	SE 608 ZZSTMSA7
	24	8	0.3	SV 628 ZZST	SE 628 ZZSTMSA7
9	24	7	0.3	SV 609 ZZST	SE 609 ZZSTMSA7
	26	8	0.6	SV 629 ZZST	SE 629 ZZSTMSA7
10	26	8	0.3	SV 6000 ZZST	SE 6000 ZZSTMSA7
	30	9	0.6	SV 6200 ZZST	SE 6200 ZZSTMSA7
12	28	8	0.3	SV 6001 ZZST	SE 6001 ZZSTMSA7
	32	10	0.6	SV 6201 ZZST	SE 6201 ZZSTMSA7
15	32	9	0.3	SV 6002 ZZST	SE 6002 ZZSTMSA7
	35	11	0.6	SV 6202 ZZST	SE 6202 ZZSTMSA7
17	35	10	0.3	SV 6003 ZZST	SE 6003 ZZSTMSA7
	40	12	0.6	SV 6203 ZZST	SE 6203 ZZSTMSA7

[Note] 1) The value in () shows the minimum chamfer dimension of open type bearings. If there is no indication, the value is the same as that of the shielded type (zz).

(Refer.)

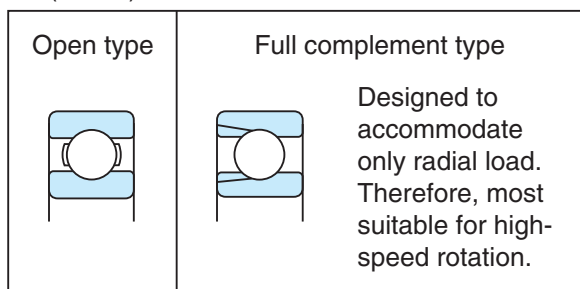

	10 ⁻³ to 10 ⁻¹⁰ Pa Ag ion-plating (balls)	(Refer.) Basic bearing Basic load ratings (kN)		
		Bearing No.	C _r	C _{0r}
	— SE 604 ZZSTMG3 SE 624 ZZSTMG3	WML4010 604 624	0.65 0.97 1.30	0.23 0.36 0.49
	SE 605 ZZSTMG3 SE 625 ZZSTMG3	605 625	1.30 1.75	0.49 0.67
	— — SE 686 ZZSTMG3 SE 606 ZZSTMG3 SE 626 ZZSTMG3	WML6010 WML6012 686 606 626	0.36 0.71 1.10 1.95 2.60	0.16 0.29 0.44 0.74 1.05
	SE 607 ZZSTMG3 SE 627 ZZSTMG3	607 627	2.60 3.30	1.05 1.35
	SE 608 ZZSTMG3 SE 628 ZZSTMG3	608 628	3.30 3.35	1.35 1.40
	SE 609 ZZSTMG3 SE 629 ZZSTMG3	609 629	3.35 4.55	1.40 1.95
	SE 6000 ZZSTMG3 SE 6200 ZZSTMG3	6000 6200	4.55 5.10	1.95 2.40
	SE 6001 ZZSTMG3 SE 6201 ZZSTMG3	6001 6201	5.10 6.80	2.40 3.05
	SE 6002 ZZSTMG3 SE 6202 ZZSTMG3	6002 6202	5.60 7.65	2.85 3.75
	SE 6003 ZZSTMG3 SE 6203 ZZSTMG3	6003 6203	6.00 9.55	3.25 4.80

EXSEV bearing series

for use in a vacuum environment

d 20 ~ 40 mm

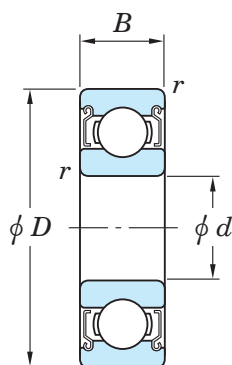

Boundary dimensions (mm)				Bearing No.		
d	D	B	r ¹⁾ min.	Atmospheric pressure to 10^{-5} Pa		
				With vacuum grease filled	MoS ₂ coating (cage)	
20	42	12	0.6	SV 6004 ZZST	SE 6004 ZZSTMSA7	
	47	14	1	SV 6204 ZZST	SE 6204 ZZSTMSA7	
25	47	12	0.6	SV 6005 ZZST	SE 6005 ZZSTMSA7	
	52	15	1	SV 6205 ZZST	SE 6205 ZZSTMSA7	
30	55	13	1	SV 6006 ZZST	SE 6006 ZZSTMSA7	
	62	16	1	SV 6206 ZZST	SE 6206 ZZSTMSA7	
35	62	14	1	SV 6007 ZZST	SE 6007 ZZSTMSA7	
	72	17	1.1	SV 6207 ZZST	SE 6207 ZZSTMSA7	
40	68	15	1	SV 6008 ZZST	SE 6008 ZZSTMSA7	
	80	18	1.1	SV 6208 ZZST	SE 6208 ZZSTMSA7	

[Note] 1) The value in () shows the minimum chamfer dimension of open type bearings. If there is no indication, the value is the same as that of the shielded type (zz).

(Refer.)

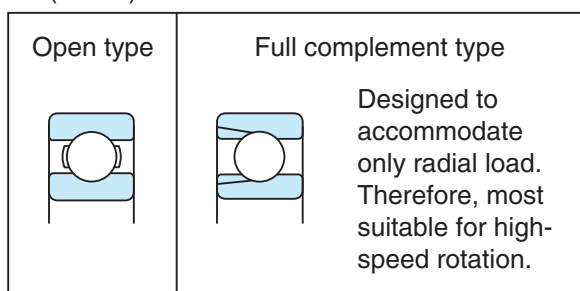

	10 ⁻³ to 10 ⁻¹⁰ Pa Ag ion-plating (balls)	(Refer.) Basic bearing Basic load ratings (kN)		
		Bearing No.	C _r	C _{0r}
	SE 6004 ZZSTMG3 SE 6204 ZZSTMG3	6004 6204	9.40 12.8	5.05 6.65
	SE 6005 ZZSTMG3 SE 6205 ZZSTMG3	6005 6205	10.1 14.0	5.85 7.85
	SE 6006 ZZSTMG3 SE 6206 ZZSTMG3	6006 6206	13.2 19.5	8.25 11.3
	SE 6007 ZZSTMG3 SE 6207 ZZSTMG3	6007 6207	15.9 25.7	10.3 15.4
	SE 6008 ZZSTMG3 SE 6208 ZZSTMG3	6008 6208	16.7 29.1	11.5 17.8

EXSEV bearing series

for use in a clean environment

d 4 ~ (25) mm

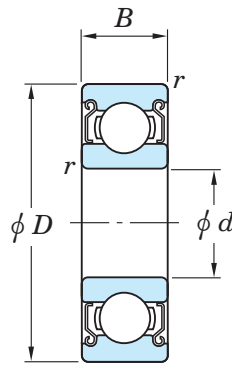

Boundary dimensions (mm)				Bearing No.		
d	D	B	r min.	<120°C Clean Class10	<200°C Clean Class10	
4	12	4	0.2	SE 604 ZZSTPRA	SE 604 ZZSTPR	
	13	5	0.2	SE 624 ZZSTPRA	SE 624 ZZSTPR	
5	14	5	0.2	SE 605 ZZSTPRA	SE 605 ZZSTPR	
	16	5	0.3	SE 625 ZZSTPRA	SE 625 ZZSTPR	
6	12	4	—	SEWML6012-1 ZZSTPRA	SEWML6012-1 ZZSTPR	
	13	5	—	SEW686 ZZSTPRA	SEW686 ZZSTPR	
	17	6	0.3	SE 606 ZZSTPRA	SE 606 ZZSTPR	
	19	6	0.3	SE 626 ZZSTPRA	SE 626 ZZSTPR	
7	19	6	0.3	SE 607 ZZSTPRA	SE 607 ZZSTPR	
	22	7	0.3	SE 627 ZZSTPRA	SE 627 ZZSTPR	
8	22	7	0.3	SE 608 ZZSTPRA	SE 608 ZZSTPR	
	24	8	0.3	SE 628 ZZSTPRA	SE 628 ZZSTPR	
9	24	7	0.3	SE 609 ZZSTPRA	SE 609 ZZSTPR	
	26	8	0.6	SE 629 ZZSTPRA	SE 629 ZZSTPR	
10	26	8	0.3	SE 6000 ZZSTPRA	SE 6000 ZZSTPR	
	30	9	0.6	SE 6200 ZZSTPRA	SE 6200 ZZSTPR	
12	28	8	0.3	SE 6001 ZZSTPRA	SE 6001 ZZSTPR	
	32	10	0.6	SE 6201 ZZSTPRA	SE 6201 ZZSTPR	
15	32	9	0.3	SE 6002 ZZSTPRA	SE 6002 ZZSTPR	
	35	11	0.6	SE 6202 ZZSTPRA	SE 6202 ZZSTPR	
17	35	10	0.3	SE 6003 ZZSTPRA	SE 6003 ZZSTPR	
	40	12	0.6	SE 6203 ZZSTPRA	SE 6203 ZZSTPR	
20	42	12	0.6	SE 6004 ZZSTPRA	SE 6004 ZZSTPR	
	47	14	1	SE 6204 ZZSTPRA	SE 6204 ZZSTPR	
25	47	12	0.6	SE 6005 ZZSTPRA	SE 6005 ZZSTPR	

	<260°C Clean Class10
	SE 604 ZZSTPRB SE 624 ZZSTPRB
	SE 605 ZZSTPRB SE 625 ZZSTPRB
	SEWML6012-1 ZZSTPRB SEW686 ZZSTPRB SE 606 ZZSTPRB SE 626 ZZSTPRB
	SE 607 ZZSTPRB SE 627 ZZSTPRB
	SE 608 ZZSTPRB SE 628 ZZSTPRB
	SE 609 ZZSTPRB SE 629 ZZSTPRB
	SE 6000 ZZSTPRB SE 6200 ZZSTPRB
	SE 6001 ZZSTPRB SE 6201 ZZSTPRB
	SE 6002 ZZSTPRB SE 6202 ZZSTPRB
	SE 6003 ZZSTPRB SE 6203 ZZSTPRB
	SE 6004 ZZSTPRB SE 6204 ZZSTPRB
	SE 6005 ZZSTPRB

EXSEV bearing series

for use in a clean environment

d (25) ~ 40 mm

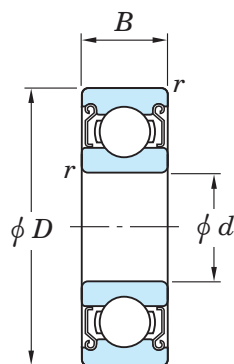

Boundary dimensions (mm)				Bearing No.		
d	D	B	r min.	<120°C Clean Class10	<200°C Clean Class10	
25	52	15	1	SE 6205 ZZSTPRA	SE 6205 ZZSTPR	
30	55	13	1	SE 6006 ZZSTPRA	SE 6006 ZZSTPR	
	62	16	1	SE 6206 ZZSTPRA	SE 6206 ZZSTPR	
35	62	14	1	SE 6007 ZZSTPRA	SE 6007 ZZSTPR	
	72	17	1.1	SE 6207 ZZSTPRA	SE 6207 ZZSTPR	
40	68	15	1	SE 6008 ZZSTPRA	SE 6008 ZZSTPR	
	80	18	1.1	SE 6208 ZZSTPRA	SE 6208 ZZSTPR	

	<260°C Clean Class10
	SE 6205 ZZSTPRB
	SE 6006 ZZSTPRB SE 6206 ZZSTPRB
	SE 6007 ZZSTPRB SE 6207 ZZSTPRB
	SE 6008 ZZSTPRB SE 6208 ZZSTPRB

Ceramic bearing series

d 4 ~ 25 mm

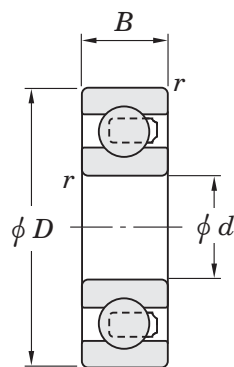

Boundary dimensions (mm)				Bearing No. Hybrid ceramic type			
d	D	B	r min.	High temperature (up to 500°C)	For corrosion resistance	Non magnetism	Insulation
4	12	4	0.2	—	3NC604MD4	3NC604YH4	3NC604ST4
	13	5	0.2	—	3NC624MD4	3NC624YH4	3NC624ST4
5	14	5	0.2	—	3NC605MD4	3NC605YH4	3NC605ST4
	16	5	0.3	—	3NC625MD4	3NC625YH4	3NC625ST4
6	17	6	0.3	3NC606HT4 GF	3NC606MD4	3NC606YH4	3NC606ST4
	19	6	0.3	3NC626HT4 GF	3NC626MD4	3NC626YH4	3NC626ST4
7	19	6	0.3	3NC607HT4 GF	3NC607MD4	3NC607YH4	3NC607ST4
	22	7	0.3	3NC627HT4 GF	3NC627MD4	3NC627YH4	3NC627ST4
8	22	7	0.3	3NC608HT4 GF	3NC608MD4	3NC608YH4	3NC608ST4
	24	8	0.3	3NC628HT4 GF	3NC628MD4	3NC628YH4	3NC628ST4
9	24	7	0.3	3NC609HT4 GF	3NC609MD4	3NC609YH4	3NC609ST4
	26	8	0.6	3NC629HT4 GF	3NC629MD4	3NC629YH4	3NC629ST4
10	26	8	0.3	3NC6000HT4 GF	3NC6000MD4	3NC6000YH4	3NC6000ST4
	30	9	0.6	3NC6200HT4 GF	3NC6200MD4	3NC6200YH4	3NC6200ST4
12	28	8	0.3	3NC6001HT4 GF	3NC6001MD4	3NC6001YH4	3NC6001ST4
	32	10	0.6	3NC6201HT4 GF	3NC6201MD4	3NC6201YH4	3NC6201ST4
15	32	9	0.3	3NC6002HT4 GF	3NC6002MD4	3NC6002YH4	3NC6002ST4
	35	11	0.6	3NC6202HT4 GF	3NC6202MD4	3NC6202YH4	3NC6202ST4
17	35	10	0.3	3NC6003HT4 GF	3NC6003MD4	3NC6003YH4	3NC6003ST4
	40	12	0.6	3NC6203HT4 GF	3NC6203MD4	3NC6203YH4	3NC6203ST4
20	42	12	0.6	3NC6004HT4 GF	3NC6004MD4	3NC6004YH4	3NC6004ST4
	47	14	1	3NC6204HT4 GF	3NC6204MD4	3NC6204YH4	3NC6204ST4
25	47	12	0.6	3NC6005HT4 GF	3NC6005MD4	3NC6005YH4	3NC6005ST4
	52	15	1	3NC6205HT4 GF	3NC6205MD4	3NC6205YH4	3NC6205ST4

Full ceramic type	
High temperature (up to 800°C)	For corrosion resistance/ Non magnetism/Insulation
— —	NC604 NC624
— —	NC605 NC625
NC706V NC726V	NC606 NC626
NC707V NC727V	NC607 NC627
NC708V NC728V	NC608 NC628
NC709V NC729V	NC609 NC629
NC7000V NC7200V	NC6000 NC6200
NC7001V NC7201V	NC6001 NC6201
NC7002V NC7202V	NC6002 NC6202
NC7003V NC7203V	NC6003 NC6203
NC7004V NC7204V	NC6004 NC6204
NC7005V NC7205V	NC6005 NC6205

Ceramic bearing series

d 30 ~ 40 mm

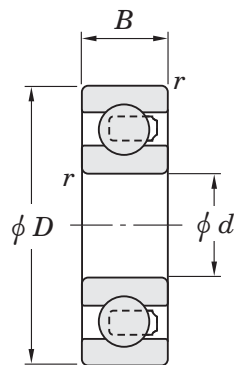

Boundary dimensions (mm)				Bearing No. Hybrid ceramic type				
d	D	B	r min.	High temperature (up to 500°C)	For corrosion resistance	Non magnetism	Insulation	
30	55	13	1	3NC6006HT4 GF	3NC6006MD4	3NC6006YH4	3NC6006ST4	
	62	16	1	3NC6206HT4 GF	3NC6206MD4	3NC6206YH4	3NC6206ST4	
35	62	14	1	3NC6007HT4 GF	3NC6007MD4	3NC6007YH4	3NC6007ST4	
	72	17	1.1	3NC6207HT4 GF	3NC6207MD4	3NC6207YH4	3NC6207ST4	
40	68	15	1	3NC6008HT4 GF	3NC6008MD4	3NC6008YH4	3NC6008ST4	
	80	18	1.1	3NC6208HT4 GF	3NC6208MD4	3NC6208YH4	3NC6208ST4	

	Full ceramic type	
	High temperature (up to 800°C)	For corrosion resistance/ Non magnetism/Insulation
	NC7006V NC7206V	NC6006 NC6206
	NC7007V NC7207V	NC6007 NC6207
	NC7008V NC7208V	NC6008 NC6208

Refer. Hybrid ceramic bearings (for high speed applications)

d 15 ~ (75) mm

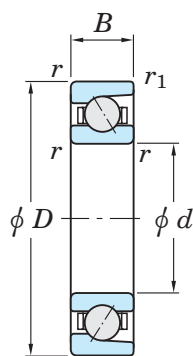

70,72 series

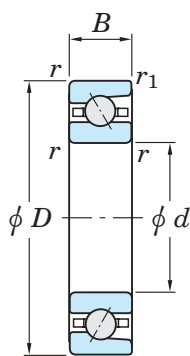

HAR 0,9 series

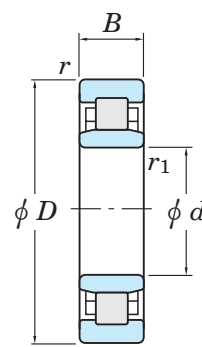

NU 10 series

Boundary dimensions (mm)					Bearing No.		
d	D	B	r min.	r_1 min.	Angular contact ball bearings		Cylindrical roller bearings
					70,72 series	HAR 0,9 series	NU 10 series
15	32	9	0.3	0.15	3NC 7002 FT	—	—
	35	11	0.6	0.3	3NC 7202 FT	—	—
20	42	12	0.6	0.3	3NC 7004 FT	—	—
	47	14	1	0.6	3NC 7204 FT	—	—
25	47	12	0.6	0.3	3NC 7005 FT	—	—
	52	15	1	0.6	3NC 7205 FT	—	—
30	55	13	1	0.6	3NC 7006 FT	3NC HAR006C FT	—
	62	16	1	0.6	3NC 7206 FT	—	—
35	62	14	1	0.6	3NC 7007 FT	3NC HAR007C FT	—
	72	17	1.1	0.6	3NC 7207 FT	—	—
40	68	15	1	0.6	3NC 7008 FT	3NC HAR008C FT	—
	80	18	1.1	0.6	3NC 7208 FT	—	—
45	75	16	1	0.6	3NC 7009 FT	3NC HAR009C FT	—
50	72	12	0.6	0.3	—	3NC HAR910C FT	—
	80	16	1	0.6	3NC 7010 FT	3NC HAR010C FT	3NC NU1010 FY
55	80	13	1	0.6	—	3NC HAR911C FT	—
	90	18	1.1	0.6	3NC 7011 FT	3NC HAR011C FT	3NC NU1011 FY
60	85	13	1	0.6	—	3NC HAR912C FT	—
	95	18	1.1	0.6	3NC 7012 FT	3NC HAR012C FT	3NC NU1012 FY
65	90	13	1	0.6	—	3NC HAR913C FT	—
	100	18	1.1	0.6	3NC 7013 FT	3NC HAR013C FT	3NC NU1013 FY
70	100	16	1	0.6	—	3NC HAR914C FT	—
	110	20	1.1	0.6	3NC 7014 FT	3NC HAR014C FT	3NC NU1014 FY
75	105	16	1	0.6	—	3NC HAR915C FT	—

* This type of bearing is mainly used in high speed rotating parts such as machine tool spindles. Since rolling elements are made of ceramics, this type of bearing is shown here, even though not designed as EXSEV bearing series.
(Bearing rings are made of high carbon chromium bearing steel)

Bearing No.	Basic load ratings (kN)		(Refer.)	Basic bearing		Bearing No.	Basic load ratings (kN)	
	C_r	C_{Or}	Bearing No.	C_r	C_{Or}		C_r	C_{Or}
70,72	C_r	C_{Or}	HAR 0,9	C_r	C_{Or}	NU 10	C_r	C_{Or}
7002	6.10	3.45	—	—	—	—	—	—
7202	8.10	4.25	—	—	—	—	—	—
7004	10.3	6.10	—	—	—	—	—	—
7204	14.5	8.40	—	—	—	—	—	—
7005	11.3	7.40	—	—	—	—	—	—
7205	15.3	9.50	—	—	—	—	—	—
7006	14.5	10.1	HAR006C	8.7	4.85	—	—	—
7206	21.3	13.7	—	—	—	—	—	—
7007	17.5	12.6	HAR007C	9.25	5.55	—	—	—
7207	28.1	18.6	—	—	—	—	—	—
7008	18.7	14.6	HAR008C	9.70	6.20	—	—	—
7208	33.6	23.3	—	—	—	—	—	—
7009	22.2	17.7	HAR009C	10.9	7.1	—	—	—
—	—	—	HAR910C	9.10	6.30	—	—	—
7010	23.6	20.1	HAR010C	11.4	7.85	NU1010	33.6	36.8
—	—	—	HAR911C	10.1	7.65	—	—	—
7011	31.1	26.3	HAR011C	14.1	9.9	NU1011	37.4	43.8
—	—	—	HAR912C	9.95	7.75	—	—	—
7012	31.9	28.1	HAR012C	14.7	10.8	NU1012	42.1	50.0
—	—	—	HAR913C	11.8	9.45	—	—	—
7013	33.7	31.4	HAR013C	15.3	11.8	NU1013	43.3	52.9
—	—	—	HAR914C	12.9	10.5	—	—	—
7014	42.7	39.4	HAR014C	20.7	15.5	NU1014	57.9	70.4
—	—	—	HAR915C	13.3	11.2	—	—	—

Refer. Hybrid ceramic bearings (for high speed applications)

d (75) ~ 120 mm

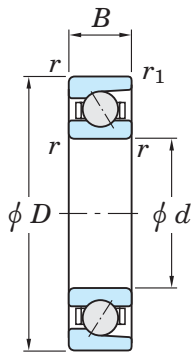

70,72 series

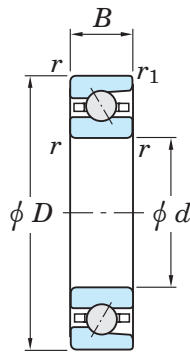

HAR 0,9 series

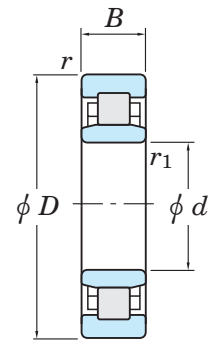

NU 10 series

Boundary dimensions (mm)					Bearing No.		
d	D	B	r min.	r_1 min.	Angular contact ball bearings 70,72 series	Cylindrical roller bearings NU 10 series	
					HAR 0,9 series		
75	115	20	1.1	0.6	3NC 7015 FT	3NC HAR015C FT	3NC NU1015 FY
80	110	16	1	0.6	—	3NC HAR916C FT	—
	125	22	1.1	0.6	—	3NC HAR016C FT	3NC NU1016 FY
85	120	18	1.1	0.6	—	3NC HAR917C FT	—
	130	22	1.1	0.6	—	3NC HAR017C FT	3NC NU1017 FY
90	125	18	1.1	0.6	—	3NC HAR918C FT	—
	140	24	1.5	1	—	3NC HAR018C FT	3NC NU1018 FY
95	130	18	1.1	0.6	—	3NC HAR919C FT	—
	145	24	1.5	1	—	3NC HAR019C FT	3NC NU1019 FY
100	140	20	1.1	0.6	—	3NC HAR920C FT	—
	150	24	1.5	1	—	3NC HAR020C FT	3NC NU1020 FY
105	145	20	1.1	0.6	—	3NC HAR921C FT	—
	160	26	2	1	—	3NC HAR021C FT	—
110	150	20	1.1	0.6	—	3NC HAR922C FT	—
	170	28	2	1	—	3NC HAR022C FT	—
120	165	22	1.1	0.6	—	3NC HAR924C FT	—
	180	28	2	1	—	3NC HAR024C FT	—

* This type of bearing is mainly used in high speed rotating parts such as machine tool spindles. Since rolling elements are made of ceramics, this type of bearing is shown here, even though not designed as EXSEV bearing series.
(Bearing rings are made of high carbon chromium bearing steel)

Bearing No.	Basic load ratings (kN)		(Refer.) Basic bearing			Bearing No.	Basic load ratings (kN)	
	C_r	C_{0r}	Bearing No.	C_r	C_{0r}		C_r	C_{0r}
70,72	C_r	C_{0r}	HAR 0,9	C_r	C_{0r}	NU 10	C_r	C_{0r}
7015	43.6	41.7	HAR015C	21.1	16.2	NU1015	63.6	78.1
—	—	—	HAR916C	13.6	11.9	—	—	—
—	—	—	HAR016C	24.7	19.2	NU1016	69.3	86.4
—	—	—	HAR917C	16.3	14.2	—	—	—
—	—	—	HAR017C	25.1	20.1	NU1017	71.4	91.2
—	—	—	HAR918C	16.8	15.1	—	—	—
—	—	—	HAR018C	32.8	26.1	NU1018	84.7	109
—	—	—	HAR919C	17.3	16.0	—	—	—
—	—	—	HAR019C	33.4	27.2	NU1019	87.2	115
—	—	—	HAR920C	24.2	21.7	—	—	—
—	—	—	HAR020C	34.0	28.4	NU1020	91.0	120
—	—	—	HAR921C	24.9	23.1	—	—	—
—	—	—	HAR021C	38.6	32.5	—	—	—
—	—	—	HAR922C	25.1	23.8	—	—	—
—	—	—	HAR022C	43.4	37.0	—	—	—
—	—	—	HAR924C	29.4	28.4	—	—	—
—	—	—	HAR024C	44.9	39.9	—	—	—

EXSEV bearing series

Linear ball bearings for vacuum

d 3 ~ 60 mm

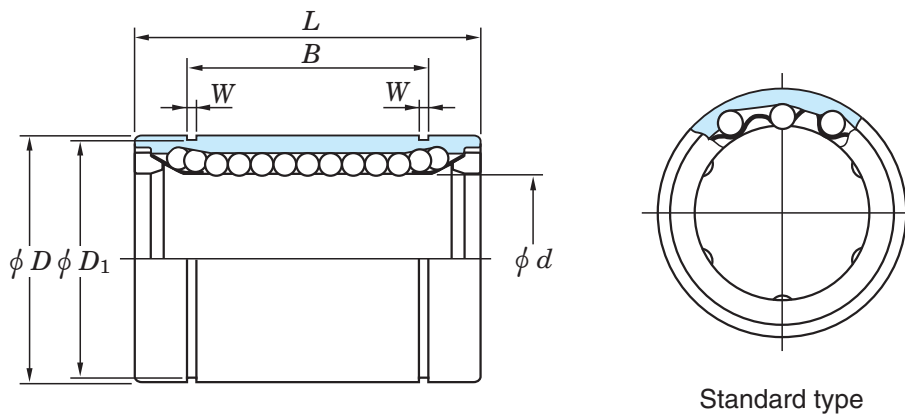

Shaft dia. (mm)	Boundary dimensions (mm)								Bearing No.	
	d	D	L	B	W	D_1	h	h_1		θ
										Standard type
3	7	10	—	—	—	—	—	—	—	SES DM 3
4	8	12	—	—	—	—	—	—	—	SES DM 4
5	10	15	10.2	1.1	9.6	—	—	—	—	SES DM 5
6	12	19	13.5	1.1	11.5	—	—	—	—	SES DM 6
8	15	17	11.5	1.1	14.3	—	—	—	—	SES DM 8S
	15	24	17.5	1.1	14.3	—	—	—	—	SES DM 8
10	19	29	22	1.3	18	—	—	—	—	SES DM 10
12	21	30	23	1.3	20	1.5	8	80°	—	SES DM 12
13	23	32	23	1.3	22	1.5	9	80°	—	SES DM 13
16	28	37	26.5	1.6	27	1.5	11	80°	—	SES DM 16
20	32	42	30.5	1.6	30.5	1.5	11	60°	—	SES DM 20
25	40	59	41	1.85	38	2	12	50°	—	SES DM 25
30	45	64	44.5	1.85	43	2.5	15	50°	—	SES DM 30
35	52	70	49.5	2.1	49	2.5	17	50°	—	SES DM 35
40	60	80	60.5	2.1	57	3	20	50°	—	SES DM 40
50	80	100	74	2.6	76.5	3	25	50°	—	SES DM 50
60	90	110	85	3.15	86.5	3	30	50°	—	SES DM 60

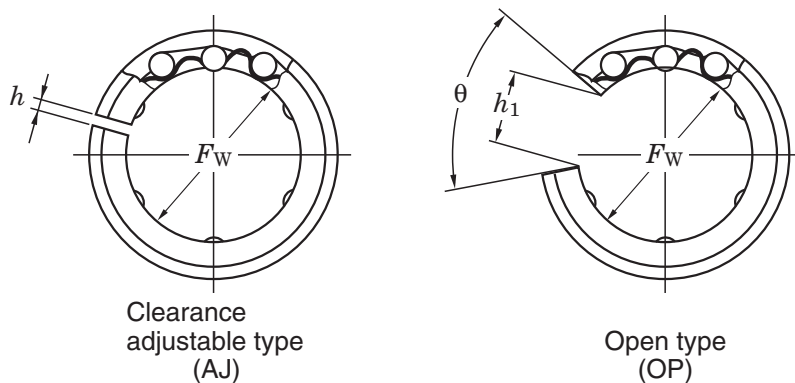

Clearance adjustable type	Open type	Basic load ratings (kN)		No. of ball rows		
		C	C_0	Standard type	Clearance adjustable type	Open type
—	—	69	105	4	—	—
—	—	88	127	4	—	—
—	—	167	206	4	—	—
—	—	206	265	4	—	—
—	—	176	216	4	—	—
—	—	274	392	4	—	—
—	—	372	549	4	—	—
SES DM12 AJ	SES DM12 OP	510	784	4	4	3
SES DM13 AJ	SES DM13 OP	510	784	4	4	3
SES DM16 AJ	SES DM16 OP	774	1 180	4	4	3
SES DM20 AJ	SES DM20 OP	882	1 370	5	5	4
SES DM25 AJ	SES DM25 OP	980	1 570	6	6	5
SES DM30 AJ	SES DM30 OP	1 570	2 740	6	6	5
SES DM35 AJ	SES DM35 OP	1 670	3 140	6	6	5
SES DM40 AJ	SES DM40 OP	2 160	4 020	6	6	5
SES DM50 AJ	SES DM50 OP	3 820	7 940	6	6	5
SES DM60 AJ	SES DM60 OP	4 700	10 000	6	6	5

KOYO



K-series super thin section ball bearings

Koyo K-series super thin section ball bearings were developed to meet current engineering needs for thinner, lighter bearings. They are used extensively in automation and labor saving equipment, such as industrial robots.

These bearings are sorted into nine dimension series according to cross-sectional area.

Those of the same dimension series have an equivalent cross-sectional area irrespective of the bore diameter.

They are available in three types that differ in structure.

■ Deep groove type

Carries radial load, axial load in both directions, and combined loads.

■ Angular contact type

Has a 30° contact angle, and carries radial load and axial load in one direction.

Two bearings are usually used together facing one another.

■ Four-point contact type

Has a contact angle of 30° both to the right and to the left.

Able to carry axial load in both directions. Also able to support moment and radial loads.

Dimension series code	Cross-sectional dimension $B = E$ (mm)	Bearing type code			Bore diameter (mm)
		C (Deep groove type)	A (Angular contact type)	X (Four-point contact type)	
T	4.762	K T C	K T A	K T X	25.4 to 38.1
A	6.35	K A C	K A A	K A X	50.8 to 304.8
B	7.938	K B C	K B A	K B X	50.8 to 508
C	9.525	K C C	K C A	K C X	101.6 to 762
D	12.7	K D C	K D A	K D X	
F	19.05	K F C	K F A	K F X	101.6 to 1 016
G	25.4	K G C	K G A	K G X	
J	$B = 11.1$ $E = 9.525$	—	KJA...RD 	—	101.6 to 304.8
U	$B = 12.7$ $E = 9.525$	KUC...2RD 	—	KUX...2RD 	

Unit : μm

	Radial runout of assembled bearing ring, max.									Assembled bearing ring face runout with raceway, max.				Bore diameter number
	Inner ring K_{ia}					Outer ring K_{ea}				Inner ring S_{ia}		Outer ring S_{ea}		
	class K0		class K3	classes K1, K4	classes K2, K6	class K0		class K3	classes K1, K4	classes K2, K6	classes K1, K4	classes K0, K2, K3, K6	classes K1, K4	
div. I	div. II				div. I	div. II								
	13	8	8	5	4	20	10	10	5	5	8	8	8	010
	15	10				25	13	13	8					10
	20	13	10	8	5	30	15	15	10	8	10	13	13	020
		15					36	20						20
	25	15	13	8	5	41	25	23	13	8	10	15	15	030
		20					46	30						25
	30	25	15	8	5	51	41	41	20	13	10	15	15	040
		15					46	30	25					10
	30	25	15	8	5	51	46	46	23	13	10	15	15	045
		20					51	41	20					10
	41	30	20	10	10	51	51	51	20	13	10	15	15	050
		30		51			41	20	10					055
	46	36	25	13	10	51	51	51	23	13	10	15	15	060
		36		51	41		20	10	065					
	46	36	25	13	10	51	51	51	23	13	10	15	15	070
		30		51	41		20	10	075					
	51	41	36	18	10	51	51	51	20	13	10	15	15	080
		41		51			41	20	10					085
	51	46	41	20	10	51	51	51	23	13	10	15	15	090
		46		51			41	20	10					095
	51	51	41	20	10	51	51	51	23	13	10	15	15	100
		51		51			41	20	10					105
	51	51	41	20	10	51	51	51	23	13	10	15	15	110
		51		51			41	20	10					115
	51	51	41	20	10	51	51	51	23	13	10	15	15	120
		51		51			41	20	10					125
	51	51	41	20	10	51	51	51	23	13	10	15	15	130
		51		51			41	20	10					135
	51	51	41	20	10	51	51	51	23	13	10	15	15	140
		51		51			41	20	10					145
	51	51	41	20	10	51	51	51	23	13	10	15	15	150
		51		51			41	20	10					155
	51	51	41	20	10	51	51	51	23	13	10	15	15	160
		51		51			41	20	10					165
	51	51	41	20	10	51	51	51	23	13	10	15	15	170
		51		51			41	20	10					175
	51	51	41	20	10	51	51	51	23	13	10	15	15	180
		51		51			41	20	10					185
	51	51	41	20	10	51	51	51	23	13	10	15	15	190
		51		51			41	20	10					195
	51	51	41	20	10	51	51	51	23	13	10	15	15	200
		51		51			41	20	10					205
	51	51	41	20	10	51	51	51	23	13	10	15	15	210
		51		51			41	20	10					215
	51	51	41	20	10	51	51	51	23	13	10	15	15	220
		51		51			41	20	10					225
	51	51	41	20	10	51	51	51	23	13	10	15	15	230
		51		51			41	20	10					235
	51	51	41	20	10	51	51	51	23	13	10	15	15	240
		51		51			41	20	10					245
	51	51	41	20	10	51	51	51	23	13	10	15	15	250
		51		51			41	20	10					255
	51	51	41	20	10	51	51	51	23	13	10	15	15	260
		51		51			41	20	10					265
	51	51	41	20	10	51	51	51	23	13	10	15	15	270
		51		51			41	20	10					275
	51	51	41	20	10	51	51	51	23	13	10	15	15	280
		51		51			41	20	10					285
	51	51	41	20	10	51	51	51	23	13	10	15	15	290
		51		51			41	20	10					295
	51	51	41	20	10	51	51	51	23	13	10	15	15	300
		51		51			41	20	10					305
	51	51	41	20	10	51	51	51	23	13	10	15	15	310
		51		51			41	20	10					315
	51	51	41	20	10	51	51	51	23	13	10	15	15	320
		51		51			41	20	10					325
	51	51	41	20	10	51	51	51	23	13	10	15	15	330
		51		51			41	20	10					335
	51	51	41	20	10	51	51	51	23	13	10	15	15	340
		51		51			41	20	10					345
	51	51	41	20	10	51	51	51	23	13	10	15	15	350
		51		51			41	20	10					355
	51	51	41	20	10	51	51	51	23	13	10	15	15	360
		51		51			41	20	10					365
	51	51	41	20	10	51	51	51	23	13	10	15	15	370
		51		51			41	20	10					375
	51	51	41	20	10	51	51	51	23	13	10	15	15	380
		51		51			41	20	10					385
	51	51	41	20	10	51	51	51	23	13	10	15	15	390
		51		51			41	20	10					395
	51	51	41	20	10	51	51	51	23	13	10	15	15	400
		51		51			41	20	10					405

Table 2 Standard radial internal clearance of deep groove and four-point contact type ball bearings Unit : μm

Bore diameter number	Radial internal clearance				
	classes K0, K1, K2		class K3	class K4	class K6
	Deep groove type	Four-point contact type			
010	25 – 41	25 – 38	18 – 28	13 – 23	10 – 20
015	30 – 46	30 – 43	20 – 30		13 – 23
020	30 – 61	30 – 56	20 – 46	15 – 30	10 – 25
025					15 – 30
030					
035	41 – 71	41 – 66	25 – 51	20 – 36	15 – 30
040					
042					
045					
047	51 – 86	51 – 76	30 – 56	25 – 41	20 – 36
050					
055					
060					
065					
070	61 – 107	61 – 86	36 – 61	25 – 41	20 – 36
075					
080					
090					
100	71 – 122	71 – 97	41 – 66	30 – 46	25 – 41
110			46 – 71		
120			30 – 46		
140	81 – 132	81 – 107	51 – 76	36 – 51	30 – 46
160	91 – 142				
180	81 – 107				
200	102 – 152				
250	152 – 203	91 – 117	61 – 86	36 – 56	30 – 46
300					
350	203 – 254	102 – 127	61 – 86	36 – 56	30 – 46
400					

Table 3 Mounting dimensions

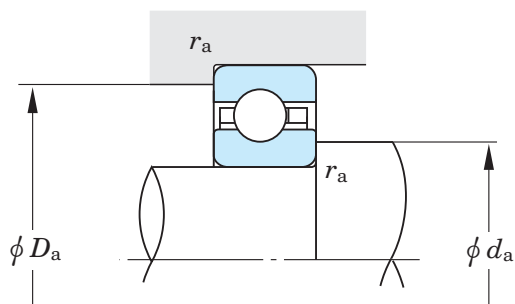

Unit : mm

Dimension series	Bearing type			ϕd_a		ϕD_a		r_a
				max.	min.	min.	max.	max.
T	KTC	KTA	KTX	$d + 5.3$	$d + 3.4$	$d + 4.2$	$d + 6.1$	0.2
A	KAC	KAA	KAX	$d + 7.3$	$d + 4.6$	$d + 5.4$	$d + 8.2$	0.4
B	KBC	KBA	KBX	$d + 9.3$	$d + 5.7$	$d + 6.6$	$d + 10.2$	0.8
C	KCC	KCA	KCX	$d + 11.3$	$d + 6.9$	$d + 7.7$	$d + 12.2$	0.8
D	KDC	KDA	KDX	$d + 15.3$	$d + 9.2$	$d + 10.1$	$d + 16.2$	1.3
F	KFC	KFA	KFX	$d + 23.3$	$d + 13.9$	$d + 14.8$	$d + 24.2$	1.8
G	KGC	KGA	KGX	$d + 31.3$	$d + 18.7$	$d + 19.5$	$d + 32.1$	1.8
J	-	KJA	-	$d + 11.3$	$d + 6.9$	$d + 7.7$	$d + 12.2$	0.2
U	KUC	-	KUX					

Table 4 Shaft diameter and housing bore diameter tolerance

Bore diameter number	Inner ring rotation									
	Shaft diameter tolerance					Housing bore diameter tolerance				
	classes K0, K1, K2		class K3	class K4	class K6	classes K0, K1, K2		class K3	class K4	class K6
	div. I	div. II				div. I	div. II			
010	+ 10 0		+ 5 0	+ 5 0	+ 4 0	+ 13 0	+ 13 0	+ 8 0	+ 5 0	+ 5 0
015	+ 13 0		+ 8 0	+ 5 0	+ 15 0	+ 15 0		+ 10 0	+ 8 0	
020	+ 15 0		+ 10 0				+ 8 0			+ 6 0
025										
030	+ 20 0		+ 13 0	+ 10 0	+ 8 0	+ 25 0	+ 15 0	+ 13 0	+ 10 0	+ 10 0
035										
040	+ 25 0		+ 15 0	+ 10 0	+ 8 0	+ 30 0	+ 18 0	+ 13 0	+ 13 0	+ 10 0
042										
045	+ 30 0		+ 18 0	+ 13 0	+ 10 0	+ 35 0	+ 35 0	+ 20 0	+ 15 0	+ 13 0
047										
050	+ 35 0		+ 20 0	+ 15 0	+ 13 0	+ 40 0	+ 40 0	+ 23 0	+ 15 0	+ 15 0
055										
060	+ 40 0		+ 23 0	+ 18 0	+ 15 0	+ 45 0	+ 40 0	+ 25 0	+ 18 0	+ 13 0
065										
070	+ 45 0		+ 25 0	+ 18 0	+ 13 0	+ 50 0	+ 45 0	+ 30 0	+ 20 0	+ 13 0
075										
080	+ 50 0		+ 45 0	+ 15 0	+ 13 0	+ 75 0	+ 45 0	+ 30 0	+ 20 0	+ 13 0
090										
100	+ 75 0		+ 25 0	+ 18 0	+ 13 0	+ 100 0	+ 50 0	+ 30 0	+ 20 0	+ 13 0
110										
120	+ 100 0		+ 45 0	+ 15 0	+ 13 0	+ 100 0	+ 50 0	+ 30 0	+ 20 0	+ 13 0
140										
160	+ 50 0		+ 25 0	+ 18 0	+ 13 0	+ 100 0	+ 50 0	+ 30 0	+ 20 0	+ 13 0
180										
200	+ 75 0		+ 45 0	+ 15 0	+ 13 0	+ 100 0	+ 50 0	+ 30 0	+ 20 0	+ 13 0
250										
300	+ 100 0		+ 45 0	+ 15 0	+ 13 0	+ 100 0	+ 50 0	+ 30 0	+ 20 0	+ 13 0
350										
400	+ 100 0		+ 45 0	+ 15 0	+ 13 0	+ 100 0	+ 50 0	+ 30 0	+ 20 0	+ 13 0
400										

[Notes] Division I is for deep groove type ball bearings.
Division II is for angular contact type and four-point contact type ball bearings.

Unit : μm

Outer ring rotation										Bore diameter number
Shaft diameter tolerance					Housing bore diameter tolerance					
classes K0, K1, K2		class K3	class K4	class K6	classes K0, K1, K2		class K3	class K4	class K6	
div. I	div. II				div. I	div. II				
- 10 - 20		- 5 - 10		- 4 - 8	- 13 - 25		- 8 - 15	- 5 - 10		010
- 13 - 25		- 8 - 15	- 5 - 10			- 13 - 25			- 5 - 10	015
- 15 - 30		- 10 - 20		- 5 - 10	- 15 - 30		- 10 - 20	- 8 - 15		020
						- 15 - 30				025
			- 8 - 15			- 15 - 30			- 8 - 15	030
- 20 - 40		- 13 - 25		- 6 - 13						035
										040
					- 20 - 40		- 13 - 25	- 10 - 20		042
										045
- 25 - 50		- 15 - 30	- 10 - 20	- 8 - 15	- 25 - 50		- 15 - 30		- 10 - 20	047
										050
										055
										060
										065
										070
- 30 - 60		- 18 - 35		- 10 - 20	- 30 - 60		- 18 - 35	- 13 - 25		075
			- 13 - 25							080
- 35 - 70		- 20 - 40		- 13 - 25	- 35 - 70		- 20 - 40		- 13 - 25	090
	- 35 - 70					- 35 - 70				100
- 48 - 80					- 40 - 80		- 23 - 45	- 15 - 30		110
										120
- 45 - 90	- 40 - 80	- 23 - 45	- 15 - 30		- 45 - 90	- 40 - 80	- 25 - 50	- 18 - 35		140
- 50 - 100		- 25 - 50	- 15 - 35		- 50 - 100		- 30 - 60	- 18 - 40		160
	- 45 - 90					- 45 - 90				180
- 75 - 150					- 75 - 150					200
										250
										300
- 100 - 200	- 50 - 100				- 100 - 200	- 50 - 100				350
										400

K-series super thin section ball bearings open type

d 25.4 ~ (114.3) mm

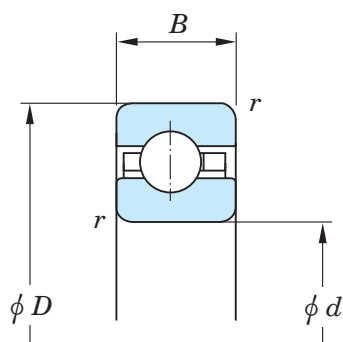

Deep groove type

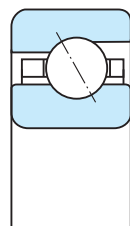

Angular contact type

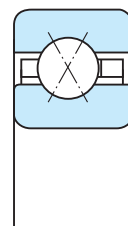

Four-point contact type

Boundary dimensions (mm)				Deep groove type			Angular contact type				
d	D	B	r min.	Bearing No.	Basic load ratings (kN)		Bearing No.	Basic load ratings (kN)			
					C_r	C_{0r}		C_r	C_{0r}	C_a	C_{0a}
25.4	34.925	4.762	0.4	KTC010	2.50	1.95	KTA010	2.65	2.20	3.45	6.70
38.1	47.625	4.762	0.4	KTC015	2.90	2.70	KTA015	3.05	3.10	4.00	9.35
50.8	63.5	6.35	0.6	KAC020	4.50	4.30	KAA020	4.75	4.95	6.25	14.9
	66.675		7.938								
63.5	76.2	6.35	0.6	KAC025	4.85	5.20	KAA025	5.10	5.95	6.75	18.0
	79.375		7.938								
76.2	88.9	6.35	0.6	KAC030	5.20	6.10	KAA030	5.45	7.00	7.15	21.2
	92.075		7.938								
88.9	101.6	6.35	0.6	KAC035	5.45	7.00	KAA035	5.75	8.00	7.55	24.3
	104.775		7.938								
101.6	114.3	6.35	0.6	KAC040	5.75	7.85	KAA040	6.00	9.05	7.90	27.4
	117.475		7.938	1	KBC040	8.10	10.5	KBA040	8.60	12.1	11.3
	120.65	9.525	1	KCC040	10.3	12.4	KCA040	11.2	14.9	14.7	45.1
	127	12.7	1.5	KDC040	15.7	17.2	KDA040	16.5	19.7	21.7	59.8
	139.7	19.05	2	KFC040	28.2	28.1	KFA040	30.3	32.9	39.8	99.6
	152.4	25.4	2	KGC040	42.6	39.6	KGA040	45.2	46.0	59.5	139
107.95	120.65	6.35	0.6	KAC042	5.85	8.30	KAA042	6.15	9.55	8.10	29.0
	123.825		7.938	1	KBC042	8.25	10.9	KBA042	8.75	12.7	11.5
	127	9.525	1	KCC042	10.5	13.0	KCA042	11.5	15.8	15.1	47.8
	133.35	12.7	1.5	KDC042	15.8	17.8	KDA042	16.8	20.8	22.1	62.9
	146.05	19.05	2	KFC042	28.8	29.4	KFA042	30.6	34.0	40.3	103
	158.75	25.4	2	KGC042	42.2	39.9	KGA042	46.2	48.0	60.8	146
114.3	127	6.35	0.6	KAC045	6.00	8.75	KAA045	6.25	10.1	8.25	30.5
	130.175		7.938	1	KBC045	8.45	11.6	KBA045	8.90	13.3	11.7
	133.35	9.525	1	KCC045	10.7	13.7	KCA045	11.7	16.6	15.4	50.4
	139.7	12.7	1.5	KDC045	16.3	19.0	KDA045	17.2	21.8	22.6	66.0

Bearing No.	Four-point contact type Basic load ratings (kN)				(Refer.) Mass (kg)		
	C_r	C_{0r}	C_a	C_{0a}	Deep groove type	Angular contact type	Four-point contact type
KTX010	2.15	1.65	3.70	7.15	0.012	0.011	0.012
KTX015	2.50	2.30	4.20	10.5	0.018	0.017	0.018
KAX020	3.90	3.70	6.60	16.9	0.045	0.045	0.045
KBX020	5.55	5.00	9.35	22.0	0.073	0.068	0.073
KAX025	4.20	4.45	7.05	20.9	0.059	0.054	0.059
KBX025	6.00	6.00	10.0	27.3	0.086	0.086	0.086
KAX030	4.50	5.25	7.45	24.9	0.068	0.064	0.068
KBX030	6.35	7.00	10.6	32.5	0.109	0.100	0.109
KAX035	4.75	6.00	7.80	29.0	0.082	0.077	0.082
KBX035	6.70	8.00	11.1	37.8	0.122	0.122	0.122
KAX040	4.95	6.80	8.10	33.0	0.086	0.086	0.086
KBX040	7.05	9.00	11.6	43.1	0.136	0.136	0.136
KCX040	8.95	10.6	14.8	50.0	0.204	0.200	0.204
KDX040	13.6	14.8	22.6	67.4	0.354	0.363	0.354
KFX040	24.6	24.0	41.0	103	0.862	0.871	0.862
KGX040	37.3	34.5	62.4	141	1.63	1.64	1.63
KAX042	5.10	7.15	8.25	35.0	0.091	0.091	0.091
KBX042	7.15	9.40	11.7	45.2	0.141	0.141	0.141
KCX042	9.15	11.2	15.0	53.0	0.213	0.209	0.213
KDX042	13.7	15.3	22.8	70.2	0.376	0.381	0.376
KFX042	25.1	25.2	41.8	109	0.907	0.925	0.907
KGX042	36.9	34.3	61.8	142	1.72	1.74	1.72
KAX045	5.20	7.55	8.40	37.0	0.100	0.095	0.100
KBX045	7.35	10.0	12.0	48.3	0.150	0.154	0.150
KCX045	9.30	11.8	15.3	56.1	0.218	0.222	0.218
KDX045	14.2	16.3	23.4	75.5	0.399	0.399	0.399

K-series super thin section ball bearings open type

d (114.3) ~ (165.1) mm

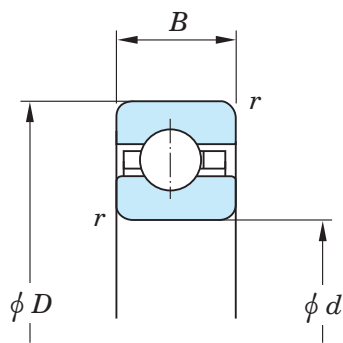

Deep groove type

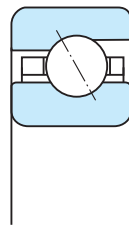

Angular contact type

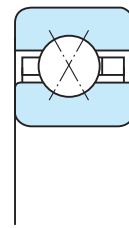

Four-point contact type

Boundary dimensions (mm)				Deep groove type Basic load ratings			Angular contact type Basic load ratings				
d	D	B	r min.	Bearing No.	C_r	C_{0r}	Bearing No.	C_r	C_{0r}	C_a	C_{0a}
114.3	152.4	19.05	2	KFC045	29.4	30.8	KFA045	31.7	36.4	41.7	110
	165.1	25.4	2	KGC045	43.6	42.7	KGA045	47.1	50.1	62.0	152
120.65	133.35	6.35	0.6	KAC047	6.10	9.20	KAA047	6.40	10.6	8.40	32.1
	136.525	7.938	1	KBC047	8.55	12.1	KBA047	9.10	14.2	12.0	42.9
	139.7	9.525	1	KCC047	10.9	14.4	KCA047	12.0	17.5	15.7	53.0
	146.05	12.7	1.5	KDC047	16.5	19.6	KDA047	17.5	22.8	23.0	69.1
	158.75	19.05	2	KFC047	29.9	32.1	KFA047	32.0	37.5	42.2	114
	171.45	25.4	2	KGC047	44.9	45.2	KGA047	48.0	52.1	63.1	158
127	139.7	6.35	0.6	KAC050	6.20	9.65	KAA050	6.50	11.1	8.55	33.6
	142.875	7.938	1	KBC050	8.80	12.8	KBA050	9.25	14.8	12.2	44.7
	146.05	9.525	1	KCC050	11.1	15.0	KCA050	12.2	18.4	16.0	55.7
	152.4	12.7	1.5	KDC050	16.9	20.8	KDA050	17.8	23.8	23.4	72.2
	165.1	19.05	2	KFC050	30.5	33.4	KFA050	32.4	38.6	42.6	117
	177.8	25.4	2	KGC050	46.2	47.6	KGA050	48.8	54.2	64.3	164
139.7	152.4	6.35	0.6	KAC055	6.40	10.5	KAA055	6.75	12.1	8.85	36.8
	155.575	7.938	1	KBC055	9.10	13.9	KBA055	9.60	16.2	12.6	49.0
	158.75	9.525	1	KCC055	11.5	16.4	KCA055	12.5	19.8	16.5	60.0
	165.1	12.7	1.5	KDC055	17.5	22.6	KDA055	18.4	25.9	24.2	78.5
	177.8	19.05	2	KFC055	31.5	36.1	KFA055	33.6	42.1	44.3	128
	190.5	25.4	2	KGC055	47.0	49.8	KGA055	50.5	58.3	66.4	177
152.4	165.1	6.35	0.6	KAC060	6.60	11.4	KAA060	6.95	13.2	9.15	39.9
	168.275	7.938	1	KBC060	9.35	15.1	KBA060	9.90	17.6	13.0	53.3
	171.45	9.525	1	KCC060	11.9	17.7	KCA060	12.9	21.5	17.0	65.3
	177.8	12.7	1.5	KDC060	18.0	24.4	KDA060	19.0	27.9	24.9	84.7
	190.5	19.05	2	KFC060	32.5	38.8	KFA060	34.8	45.6	45.8	138
	203.2	25.4	2	KGC060	49.3	54.7	KGA060	52.0	62.4	68.4	189
165.1	177.8	6.35	0.6	KAC065	6.80	12.3	KAA065	7.15	14.2	9.40	43.0
	180.975	7.938	1	KBC065	9.65	16.3	KBA065	10.1	18.8	13.3	56.9

Bearing No.	Four-point contact type Basic load ratings (kN)				(Refer.) Mass (kg)		
	C_r	C_{0r}	C_a	C_{0a}	Deep groove type	Angular contact type	Four-point contact type
KFX045	25.6	26.3	42.6	115	0.953	0.971	0.953
KGX045	38.1	36.4	63.6	152	1.81	1.79	1.81
KAX047	5.30	7.95	8.55	39.0	0.104	0.100	0.104
KBX047	7.45	10.4	12.1	50.4	0.154	0.159	0.154
KCX047	9.50	12.4	15.5	59.1	0.227	0.231	0.227
KDX047	14.3	16.8	23.6	78.2	0.426	0.422	0.426
KFX047	26.1	27.5	43.3	121	0.998	1.03	0.998
KGX047	39.2	38.6	65.4	162	1.86	1.89	1.86
KAX050	5.35	8.35	8.65	41.1	0.109	0.104	0.109
KBX050	7.60	11.0	12.4	53.6	0.172	0.168	0.172
KCX050	9.65	12.9	15.8	62.1	0.263	0.245	0.263
KDX050	14.7	17.9	24.2	83.5	0.454	0.445	0.454
KFX050	26.5	28.7	44.0	127	1.04	1.08	1.04
KGX050	40.3	40.7	67.1	173	1.95	2.00	1.95
KAX055	5.55	9.10	8.90	45.1	0.113	0.113	0.113
KBX055	7.85	12.0	12.7	58.8	0.186	0.181	0.186
KCX055	10.0	14.1	16.2	68.2	0.268	0.263	0.268
KDX055	15.2	19.4	24.9	91.6	0.481	0.481	0.481
KFX055	27.4	31.0	45.3	140	1.13	1.17	1.13
KGX055	41.0	42.6	68.0	184	2.13	2.15	2.13
KAX060	5.75	9.85	9.15	49.1	0.127	0.127	0.127
KBX060	8.10	13.0	13.1	64.1	0.200	0.200	0.200
KCX060	10.3	15.3	16.7	74.2	0.286	0.290	0.286
KDX060	15.7	21.0	25.5	99.7	0.526	0.522	0.526
KFX060	28.2	33.3	46.5	152	1.22	1.23	1.22
KGX060	42.9	46.8	71.1	205	2.31	2.30	2.31
KAX065	5.90	10.6	9.40	53.2	0.136	0.136	0.136
KBX065	8.35	14.0	13.4	69.3	0.213	0.213	0.213

K-series super thin section ball bearings open type

d (165.1) ~ 228.6 mm

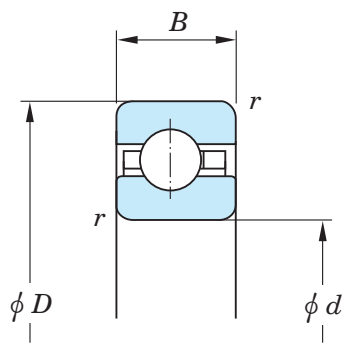

Deep groove type

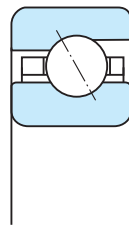

Angular contact type

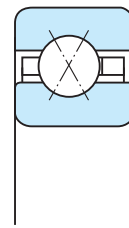

Four-point contact type

Boundary dimensions (mm)				Deep groove type			Angular contact type				
d	D	B	r min.	Bearing No.	Basic load ratings (kN)		Bearing No.	Basic load ratings (kN)			
					C_r	C_{0r}		C_r	C_{0r}	C_a	C_{0a}
165.1	184.15	9.525	1	KCC065	12.2	19.0	KCA065	13.4	23.3	17.6	70.6
	190.5	12.7	1.5	KDC065	18.6	26.1	KDA065	19.5	30.0	25.6	90.9
	203.2	19.05	2	KFC065	33.4	41.5	KFA065	36.0	49.1	47.3	149
	215.9	25.4	2	KGC065	50.0	57.0	KGA065	53.5	66.5	70.3	202
177.8	190.5	6.35	0.6	KAC070	7.00	13.2	KAA070	7.35	15.2	9.65	46.1
	193.675	7.938	1	KBC070	9.90	17.4	KBA070	10.4	20.2	13.7	61.2
	196.85	9.525	1	KCC070	12.5	20.4	KCA070	13.6	24.7	17.9	74.9
	203.2	12.7	1.5	KDC070	19.0	27.9	KDA070	20.0	32.1	26.3	97.2
	215.9	19.05	2	KFC070	34.3	44.1	KFA070	37.0	52.6	48.7	159
	228.6	25.4	2	KGC070	52.1	61.8	KGA070	54.8	70.7	72.2	214
	190.5	203.2	6.35	0.6	KAC075	7.15	14.1	KAA075	7.50	16.2	9.90
206.375		7.938	1	KBC075	10.1	18.6	KBA075	10.7	21.6	14.1	65.4
209.55		9.525	1	KCC075	12.8	21.7	KCA075	14.0	26.5	18.4	80.2
215.9		12.7	1.5	KDC075	19.5	29.7	KDA075	20.5	34.1	27.0	103
228.6		19.05	2	KFC075	35.1	46.8	KFA075	37.5	54.8	49.3	166
241.3		25.4	2	KGC075	52.6	64.1	KGA075	56.2	74.8	73.9	227
203.2		215.9	6.35	0.6	KAC080	7.35	15.0	KAA080	7.70	17.3	10.1
	219.075	7.938	1	KBC080	10.4	19.7	KBA080	11.0	23.0	14.4	69.7
	222.25	9.525	1	KCC080	13.1	23.1	KCA080	14.4	28.2	18.9	85.5
	228.6	12.7	1.5	KDC080	20.0	31.5	KDA080	21.0	36.2	27.6	110
	241.3	19.05	2	KFC080	35.9	49.5	KFA080	38.5	58.3	50.6	177
	254	25.4	2	KGC080	54.5	69.0	KGA080	57.4	78.9	75.5	239
	228.6	241.3	6.35	0.6	KAC090	7.65	16.8	KAA090	8.00	19.3	10.5
244.475		7.938	1	KBC090	10.8	22.1	KBA090	11.4	25.6	15.0	77.6
247.65		9.525	1	KCC090	13.7	25.7	KCA090	14.9	31.4	19.6	95.1
254		12.7	1.5	KDC090	20.8	35.0	KDA090	21.8	40.3	28.7	122
266.7		19.05	2	KFC090	37.4	54.8	KFA090	40.3	65.3	53.1	198
279.4		25.4	2	KGC090	56.8	76.1	KGA090	59.8	87.1	78.7	264

Bearing No.	Four-point contact type Basic load ratings (kN)				(Refer.) Mass (kg)		
	C_r	C_{0r}	C_a	C_{0a}	Deep groove type	Angular contact type	Four-point contact type
KCX065	10.6	16.4	17.1	80.3	0.308	0.308	0.308
KDX065	16.1	22.5	26.2	108	0.553	0.562	0.553
KFX065	29.0	35.6	47.7	164	1.32	1.33	1.32
KGX065	43.5	48.8	71.8	216	2.45	2.45	2.45
KAX070	6.05	11.4	9.60	57.2	0.141	0.145	0.141
KBX070	8.55	15.0	13.7	74.6	0.227	0.227	0.227
KCX070	10.9	17.6	17.5	86.3	0.331	0.336	0.331
KDX070	16.5	24.0	26.7	116	0.594	0.603	0.594
KFX070	29.8	37.9	48.7	176	1.45	1.43	1.45
KGX070	45.3	53.0	74.5	237	2.63	2.66	2.63
KAX075	6.20	12.2	9.80	61.3	0.154	0.154	0.154
KBX075	8.80	16.0	14.0	79.8	0.240	0.245	0.240
KCX075	11.1	18.7	17.8	92.4	0.354	0.354	0.354
KDX075	16.9	25.6	27.3	124	0.640	0.644	0.640
KFX075	30.5	40.2	49.8	188	1.54	1.54	1.54
KGX075	45.8	55.0	75.2	249	2.77	2.81	2.77
KAX080	6.35	13.0	10.0	65.3	0.172	0.163	0.172
KBX080	9.00	17.0	14.3	85.1	0.259	0.259	0.259
KCX080	11.4	19.9	18.2	98.5	0.381	0.381	0.381
KDX080	17.3	27.1	27.9	132	0.694	0.689	0.694
KFX080	31.2	42.5	50.7	200	1.59	1.64	1.59
KGX080	47.4	59.2	77.6	270	2.95	2.97	2.95
KAX090	6.60	14.5	10.4	73.4	0.200	0.186	0.200
KBX090	9.35	19.1	14.8	95.6	0.299	0.290	0.299
KCX090	11.9	22.2	18.9	111	0.426	0.445	0.426
KDX090	18.0	30.2	28.9	148	0.780	0.767	0.780
KFX090	32.5	47.2	52.6	224	1.77	1.79	1.77
KGX090	49.4	65.3	80.5	302	3.27	3.27	3.27

K-series super thin section ball bearings open type

d 254 ~ 406.4 mm

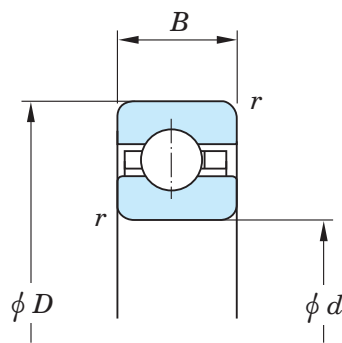

Deep groove type

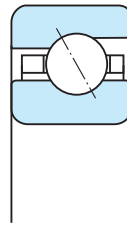

Angular contact type

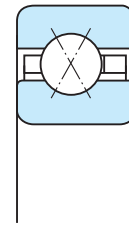

Four-point contact type

Boundary dimensions (mm)				Deep groove type Basic load ratings			Angular contact type Basic load ratings				
d	D	B	r min.	Bearing No.	(kN) C_r C_{0r}		Bearing No.	(kN) C_r C_{0r} C_a C_{0a}			
254	266.7	6.35	0.6	KAC100	7.95	18.6	KAA100	8.30	21.4	11.0	64.8
	269.875	7.938	1	KBC100	11.2	24.4	KBA100	11.9	28.4	15.6	86.1
	273.05	9.525	1	KCC100	14.2	28.4	KCA100	15.6	34.9	20.5	106
	279.4	12.7	1.5	KDC100	21.6	38.6	KDA100	22.7	44.4	29.8	135
	292.1	19.05	2	KFC100	38.8	60.2	KFA100	41.6	71.1	54.7	215
	304.8	25.4	2	KGC100	59.0	83.2	KGA100	62.0	95.3	81.6	289
	279.4	292.1	6.35	0.6	KAC110	8.20	20.3	KAA110	8.60	23.4	11.3
295.275		7.938	1	KBC110	11.6	26.7	KBA110	12.3	31.0	16.1	94.0
298.45		9.525	1	KCC110	14.7	31.1	KCA110	16.1	38.0	21.1	115
304.8		12.7	1.5	KDC110	22.3	42.2	KDA110	23.4	48.5	30.8	147
317.5		19.05	2	KFC110	40.2	65.5	KFA110	43.2	78.0	56.9	236
330.2		25.4	2	KGC110	61.0	90.3	KGA110	64.1	104	84.3	314
304.8		317.5	6.35	0.6	KAC120	8.45	22.1	KAA120	8.90	25.5	11.7
	320.675	7.938	1	KBC120	12.0	29.0	KBA120	12.7	33.8	16.7	103
	323.85	9.525	1	KCC120	15.2	33.8	KCA120	16.5	41.2	21.8	125
	330.2	12.7	1.5	KDC120	23.0	45.7	KDA120	24.2	52.6	31.8	160
	342.9	19.05	2	KFC120	41.4	70.9	KFA120	44.3	83.8	58.3	254
	355.6	25.4	2	KGC120	62.9	97.5	KGA120	66.0	112	86.9	339
	355.6	371.475	7.938	1	KBC140	12.7	33.7	KBA140	13.4	39.1	17.6
374.65		9.525	1	KCC140	16.0	39.1	KCA140	17.5	47.9	23.0	145
381		12.7	1.5	KDC140	24.3	52.9	KDA140	25.5	60.9	33.6	184
393.7		19.05	2	KFC140	43.7	81.5	KFA140	46.8	96.5	61.6	293
406.4		25.4	2	KGC140	66.3	112	KGA140	69.7	128	91.7	389
406.4		422.275	7.938	1	KBC160	13.3	38.3	KBA160	14.0	44.5	18.4
	425.45	9.525	1	KCC160	16.8	44.4	KCA160	18.4	54.5	24.2	165
	431.8	12.7	1.5	KDC160	25.5	60.0	KDA160	26.8	69.1	35.2	209
	444.5	19.05	2	KFC160	45.8	92.2	KFA160	49.0	109	64.5	331
	457.2	25.4	2	KGC160	69.5	126	KGA160	73.0	145	96.0	439

Bearing No.	Four-point contact type Basic load ratings (kN)				(Refer.) Mass (kg)		
	C_r	C_{0r}	C_a	C_{0a}	Deep groove type	Angular contact type	Four-point contact type
KAX100	6.85	16.0	10.7	81.4	0.227	0.204	0.227
KBX100	9.75	21.1	15.3	106	0.331	0.322	0.331
KCX100	12.3	24.5	19.5	123	0.481	0.472	0.481
KDX100	18.7	33.3	29.8	164	0.853	0.848	0.853
KFX100	33.7	51.8	54.3	249	1.95	2.00	1.95
KGX100	51.2	71.5	83.1	334	3.58	3.63	3.58
KAX110	7.10	17.6	11.1	89.5	0.236	0.227	0.236
KBX110	10.1	23.1	15.7	117	0.340	0.354	0.340
KCX110	12.7	26.8	20.1	135	0.526	0.517	0.526
KDX110	19.3	36.4	30.7	180	0.934	0.930	0.934
KFX110	34.8	56.4	55.9	273	2.18	2.15	2.18
KGX110	52.9	77.7	85.5	366	3.90	3.94	3.90
KAX120	7.35	19.1	11.4	97.6	0.254	0.245	0.254
KBX120	10.4	25.1	16.2	127	0.376	0.386	0.376
KCX120	13.1	29.2	20.6	147	0.567	0.558	0.567
KDX120	20.0	39.5	31.5	197	1.02	1.01	1.02
KFX120	35.9	61.1	57.4	297	2.36	2.36	2.36
KGX120	54.5	83.9	87.8	399	4.22	4.30	4.22
KBX140	11.0	29.1	17.0	148	0.476	0.445	0.476
KCX140	13.9	33.8	21.6	171	0.689	0.649	0.689
KDX140	21.1	45.7	33.1	229	1.24	1.17	1.24
KFX140	37.9	70.3	60.2	345	2.72	2.61	2.72
KGX140	57.5	96.2	92.0	463	4.90	4.94	4.90
KBX160	11.5	33.1	17.7	169	0.544	0.508	0.544
KCX160	14.6	38.4	22.6	195	0.785	0.739	0.785
KDX160	22.1	51.8	34.5	261	1.41	1.33	1.41
KFX160	39.7	79.6	62.7	394	3.22	3.08	3.22
KGX160	60.3	109	95.9	528	5.58	5.62	5.58

K-series super thin section ball bearings open type

d 457.2 ~ 1 016 mm

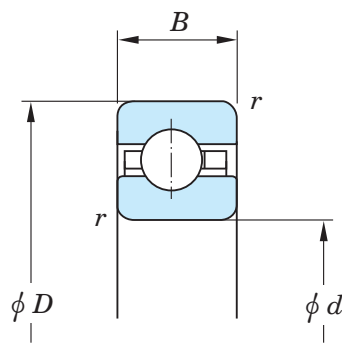

Deep groove type

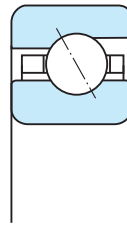

Angular contact type

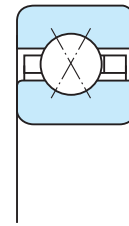

Four-point contact type

Boundary dimensions (mm)				Deep groove type			Angular contact type				
d	D	B	r min.	Bearing No.	Basic load ratings (kN)		Bearing No.	Basic load ratings (kN)			
					C_r	C_{0r}		C_r	C_{0r}	C_a	C_{0a}
457.2	473.075	7.938	1	KBC180	13.9	42.9	KBA180	14.6	49.9	19.2	151
	476.25	9.525	1	KCC180	17.5	49.8	KCA180	19.2	61.2	25.3	185
	482.6	12.7	1.5	KDC180	26.6	67.1	KDA180	27.6	77.3	36.3	234
	495.3	19.05	2	KFC180	47.8	103	KFA180	51.5	123	67.7	373
	508	25.4	2	KGC180	72.5	140	KGA180	76.0	161	100	488
508	523.875	7.938	1	KBC200	14.4	47.6	KBA200	15.2	55.3	20.0	168
	527.05	9.525	1	KCC200	18.2	55.1	KCA200	19.9	67.5	26.2	205
	533.4	12.7	1.5	KDC200	27.6	74.3	KDA200	29.0	85.6	38.1	259
	546.1	19.05	2	KFC200	49.6	114	KFA200	53.4	136	70.3	412
	558.8	25.4	2	KGC200	75.2	154	KGA200	78.9	178	104	538
635	654.05	9.525	1	KCC250	19.7	68.5	KCA250	21.6	84.0	28.4	255
	660.4	12.7	1.5	KDC250	29.9	92.1	KDA250	31.4	106	41.3	322
	673.1	19.05	2	KFC250	53.7	140	KFA250	57.6	167	75.8	506
	685.8	25.4	2	KGC250	81.4	190	KGA250	85.4	219	112	663
762	781.05	9.525	1	KCC300	21.1	81.9	KCA300	23.1	101	30.3	305
	787.4	12.7	1.5	KDC300	32.0	110	KDA300	33.5	127	44.1	384
	800.1	19.05	2	KFC300	57.3	167	KFA300	61.6	200	81.0	605
	812.8	25.4	2	KGC300	86.8	226	KGA300	91.1	260	120	788
889	927.1	19.05	2	KFC350	60.6	194	KFA350	65.2	232	85.8	703
	939.8	25.4	2	KGC350	91.7	261	KGA350	96.2	301	127	912
1 016	1 054.1	19.05	2	KFC400	63.5	221	KFA400	68.4	264	90.0	801
	1 066.8	25.4	2	KGC400	96.2	297	KGA400	101	342	133	1 040

Bearing No.	Four-point contact type Basic load ratings (kN)				(Refer.) Mass (kg)		
	C_r	C_{0r}	C_a	C_{0a}	Deep groove type	Angular contact type	Four-point contact type
KBX180	12.0	37.1	18.4	190	0.612	0.572	0.612
KCX180	15.2	43.0	23.4	220	0.880	0.830	0.880
KDX180	23.0	58.0	35.8	293	1.58	1.49	1.58
KFX180	41.4	88.8	65.0	442	3.58	3.48	3.58
KGX180	62.8	121	99.4	592	6.21	6.26	6.21
KBX200	12.5	41.2	19.0	211	0.680	0.635	0.680
KCX200	15.8	47.7	24.2	244	0.980	0.921	0.980
KDX200	23.9	64.2	37.0	326	1.75	1.66	1.75
KFX200	43.0	98.1	67.2	491	4.04	3.84	4.04
KGX200	65.2	133	103	657	8.53	6.89	8.53
KCX250	17.1	59.2	26.0	304	1.22	1.14	1.22
KDX250	25.9	79.6	39.7	407	2.17	2.06	2.17
KFX250	46.5	121	72.0	612	4.94	4.76	4.94
KGX250	70.5	164	110	819	8.85	8.53	8.85
KCX300	18.3	70.8	27.6	365	1.46	1.37	1.46
KDX300	27.7	95.0	42.1	487	2.60	2.47	2.60
KFX300	49.6	144	76.3	733	5.90	5.67	5.90
KGX300	75.2	195	116	980	10.6	10.2	10.6
KFX350	52.5	168	80.1	854	6.85	6.62	6.85
KGX350	79.4	226	122	1 140	12.3	11.9	12.3
KFX400	55.0	191	83.6	975	7.80	7.53	7.80
KGX400	83.3	257	128	1 300	14.0	13.5	14.0

K-series super thin section ball bearings sealed type

d 101.6 ~ 304.8 mm

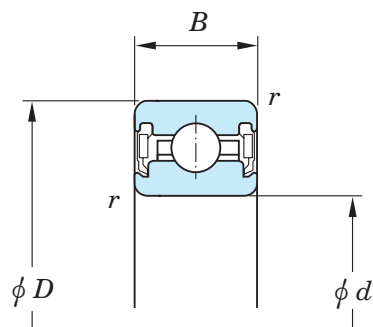

Deep groove type
U size
(With seals)

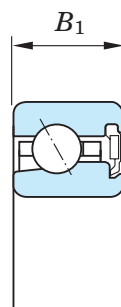

Angular contact type
J size
(With seal)

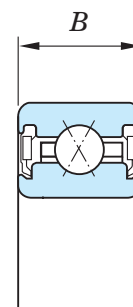

Four-point contact type
U size
(With seals)

Boundary dimensions (mm)					Deep groove type Basic load ratings			Angular contact type Basic load ratings				
d	D	B	B_1	r min.	Bearing No.	C_r	C_{0r}	Bearing No.	C_r	C_{0r}	C_a	C_{0a}
101.6	120.65	12.7	11.1	0.4	KUC040 2RD	10.3	12.4	KJA040 RD	11.2	14.9	14.7	45.1
107.95	127	12.7	11.1	0.4	KUC042 2RD	10.5	13.0	KJA042 RD	11.5	15.8	15.1	47.8
114.3	133.35	12.7	11.1	0.4	KUC045 2RD	10.7	13.7	KJA045 RD	11.7	16.6	15.4	50.4
120.65	139.7	12.7	11.1	0.4	KUC047 2RD	10.9	14.4	KJA047 RD	12.0	17.5	15.7	53.0
127	146.05	12.7	11.1	0.4	KUC050 2RD	11.1	15.0	KJA050 RD	12.2	18.4	16.0	55.7
139.7	158.75	12.7	11.1	0.4	KUC055 2RD	11.5	16.4	KJA055 RD	12.5	19.8	16.5	60.0
152.4	171.45	12.7	11.1	0.4	KUC060 2RD	11.9	17.7	KJA060 RD	12.9	21.5	17.0	65.3
165.1	184.15	12.7	11.1	0.4	KUC065 2RD	12.2	19.0	KJA065 RD	13.4	23.3	17.6	70.6
177.8	196.85	12.7	11.1	0.4	KUC070 2RD	12.5	20.4	KJA070 RD	13.6	24.7	17.9	74.9
190.5	209.55	12.7	11.1	0.4	KUC075 2RD	12.8	21.7	KJA075 RD	14.0	26.5	18.4	80.2
203.2	222.25	12.7	11.1	0.4	KUC080 2RD	13.1	23.1	KJA080 RD	14.4	28.2	18.9	85.5
228.6	247.65	12.7	11.1	0.4	KUC090 2RD	13.7	25.7	KJA090 RD	14.9	31.4	19.6	95.1
254	273.05	12.7	11.1	0.4	KUC100 2RD	14.2	28.4	KJA100 RD	15.6	34.9	20.5	106
279.4	298.45	12.7	11.1	0.4	KUC110 2RD	14.7	31.1	KJA110 RD	16.1	38.0	21.1	115
304.8	323.85	12.7	11.1	0.4	KUC120 2RD	15.2	33.8	KJA120 RD	16.5	41.2	21.8	125

Bearing No.	Four-point contact type Basic load ratings (kN)				(Refer.) Mass (kg)		
	C_r	C_{0r}	C_a	C_{0a}	Deep groove type	Angular contact type	Four-point contact type
KUX040 2RD	8.95	10.6	14.8	50.0	0.249	0.222	0.249
KUX042 2RD	9.15	11.2	15.0	53.0	0.263	0.236	0.263
KUX045 2RD	9.30	11.8	15.3	56.1	0.277	0.254	0.277
KUX047 2RD	9.50	12.4	15.5	59.1	0.295	0.268	0.295
KUX050 2RD	9.65	12.9	15.8	62.1	0.308	0.281	0.308
KUX055 2RD	10.0	14.1	16.2	68.2	0.336	0.304	0.336
KUX060 2RD	10.3	15.3	16.7	74.2	0.367	0.331	0.367
KUX065 2RD	10.6	16.4	17.1	80.3	0.395	0.354	0.395
KUX070 2RD	10.9	17.6	17.5	86.3	0.422	0.381	0.422
KUX075 2RD	11.1	18.7	17.8	92.4	0.449	0.404	0.449
KUX080 2RD	11.4	19.9	18.2	98.5	0.481	0.431	0.481
KUX090 2RD	11.9	22.2	18.9	111	0.535	0.499	0.535
KUX100 2RD	12.3	24.5	19.5	123	0.594	0.531	0.594
KUX110 2RD	12.7	26.8	20.1	135	0.649	0.581	0.649
KUX120 2RD	13.1	29.2	20.6	147	0.708	0.630	0.708

KOYO

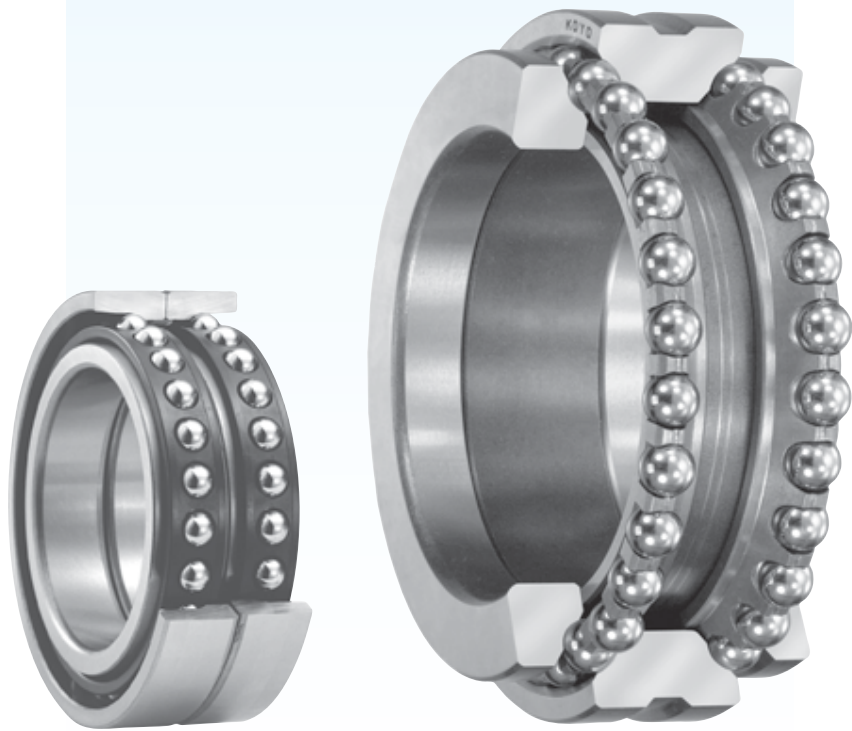

Bearings for machine tool spindles (for support of axial loading)

JTEKT supplies double direction angular contact thrust ball bearings and ACT type matched pair angular contact ball bearings which are used with machine tool spindles to support axial loading.

These bearings were developed to meet needs which have grown as machine tool spindle rotation has become faster and more accurate.

Several dimension series are available for selection according to operating conditions.

For details, refer to JTEKT separate catalog "Precision Ball and Roller Bearings for Machine Tools" (CAT. NO. B2005E).

See also the catalog for high ability bearings, CAT NO. B2006 for High Ability Ball Bearing Series Angular Contact Ball Bearings for Machining Tools.

(Reference)

Major bearing types which are used to carry radial loading of machine tool spindles are shown below.

For further details, refer to the specification table for each type.

Double direction angular contact thrust ball bearings

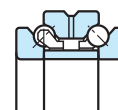

Bore diameter 25 – 340 mm

Matched pair angular contact ball bearing (ACT type)

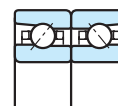

Bore diameter 50 – 170 mm

Angular contact ball bearings			Double-row cylindrical roller bearings	
<p>(for high-speed applications)</p>				
79 C 70, 70 B, 70 C 72, 72 B, 72 C	79 CPA 70 CPA 72 CPA	HAR 9 C HAR 0 C (high ability ball bearing)	NN 30 NN 30 K (Tapered bore)	NNU 49 NNU 49 K (Tapered bore)
Refer to p. B 92. (for bearings with ceramic balls,) refer to p. C 21.			Refer to p. B 194.	

Table 1 Bearing types for support of axial loading

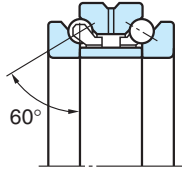
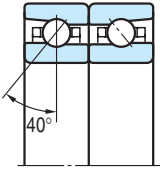
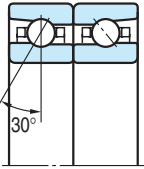
Type	Double direction angular contact thrust ball bearings		Matched pair angular contact ball bearings		Types of ¹⁾ arrangement with a double-row cylindrical roller bearing
					
Diameter series					
0	2344 B 2347 B	ACT 0 B DB —	ACT 0 DB —	① ②	
9	2394 B 2397 B	— —	— —	③ ④	
Characteristics	<ul style="list-style-type: none"> • Supports axial loading in both directions. Highly rigid in the axial direction. • Bearings with a larger contact angle feature higher rigidity, while those with a smaller contact angle feature better high-speed performance. 	<ul style="list-style-type: none"> • For support of axial loading only. Negative tolerances are specified for the outside diameter. • Excellent high-speed performance is achieved because of the small contact angle. • Interchangeable with 2344 B series bearings.²⁾ 	—		

[Notes]

1) These bearings are usually used in arrangement with a double-row cylindrical roller bearing which carries a radial load. There are four arrangement types (① to ④) as follows :

- ① Mounted with an NN30K tapered bore bearing or with an NN30 cylindrical bore bearing. The tapered bore bearing is combined at its smaller side.
- ② Mounted with an NN30K tapered bore bearing, which is combined at its larger side.
- ③ Mounted with an NNU49K tapered bore bearing or with an NNU49 cylindrical bore bearing. The tapered bore bearing is combined at its smaller side.
- ④ Mounted with an NNU49K tapered bore bearing, which is combined at its larger side.

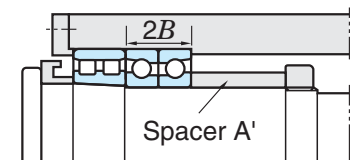
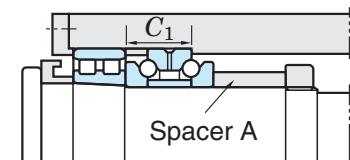

2) The overall width "2 B" of ACT0 DB and ACT0B DB bearings is equivalent to dimension "C₁" of 2344B bearings. Therefore, when a 2344B bearing is replaced with an ACT0 DB or ACT0B DB bearing, change the width of spacer "A" only. No change is necessary to the spindle or housing dimensions.

Table 2 Double direction angular contact thrust ball bearing tolerance

(1) Inner ring and assembled bearing width

Unit : μm

Nominal bore diameter d (mm)		Δ_{dmp} or $\Delta_{ds}^{1)}$				Actual bearing width deviation Δ_{Ts}		Inner ring width variation V_{Bs}		Perpendicularity of inner ring face with respect to the bore S_d		Assembled bearing inner ring face runout with raceway S_{ia}	
		class 5 or equivalent		class 4 or equivalent		classes 4 and 5, or equivalent		class 5 or equivalent	class 4 or equivalent	class 5 or equivalent	class 4 or equivalent	class 5 or equivalent	class 4 or equivalent
over	up to	upper	lower	upper	lower	upper	lower	max.		max.		max.	
18	30	0	-6	0	-5	0	-300	5	2.5	8	4	5	3
30	50	0	-8	0	-6	0	-400	5	3	8	4	5	3
50	80	0	-9	0	-7	0	-500	6	4	8	4	6	5
80	120	0	-10	0	-8	0	-600	7	4	9	5	6	5
120	180	0	-13	0	-10	0	-700	8	5	10	6	8	6
180	250	0	-15	0	-12	0	-800	10	6	11	7	8	6
250	315	0	-18	0	-15	0	-900	13	7	13	8	10	8
315	400	0	-23	0	-18	0	-1 000	15	9	15	9	13	10

(2) Outer ring

Unit : μm

Nominal outside diameter D (mm)		Δ_{Dmp} or $\Delta_{Ds}^{2)}$		Outer ring width variation V_{Cs}		Perpendicularity of outer ring outside surface with respect to the face S_D		Assembled bearing outer ring face runout with raceway S_{ea}	
		classes 5 and 4, or equivalent		class 5 or equivalent	class 4 or equivalent	class 5 or equivalent	class 4 or equivalent	classes 5 and 4, or equivalent	
over	up to	upper	lower	max.		max.		max.	
30	50	-30	-40	5	2.5	8	4	Shall conform to the tolerance S_{ia} on d of the same bearing	
50	80	-40	-50	6	3	8	4		
80	120	-50	-60	8	4	9	5		
120	150	-60	-75	8	5	10	5		
150	180	-60	-75	8	5	10	5		
180	250	-75	-90	10	7	11	7		
250	315	-90	-105	11	7	13	8		
315	400	-110	-125	13	8	13	10		
400	500	-120	-140	15	10	15	13		

[Notes] 1) Single plane mean bore diameter deviation or single bore diameter deviation

2) Single plane mean outside diameter deviation or single outside diameter deviation

Table 3 ACT 0 series angular contact ball bearing outside diameter tolerance Unit : μm

Nominal outside diameter D (mm)		Single outside diameter deviation Δ_{Ds}	
over	up to	upper	lower
50	80	-32	-47
80	120	-39	-56
120	150	-44	-66
150	180	-44	-68
180	250	-51	-79
250	315	-56	-89

[Remark] Refer to JIS B 1514 "radial bearing tolerance" class 4 and class 5 (pp. A 54 to A 57, Table 7-3) for the accuracy of dimensions other than outside diameter and for running accuracy.

[Reference] Axial load and axial displacement

The relationship between axial loading and the axial displacement of double direction angular contact thrust ball bearings and ACT type angular contact ball bearings is shown below :

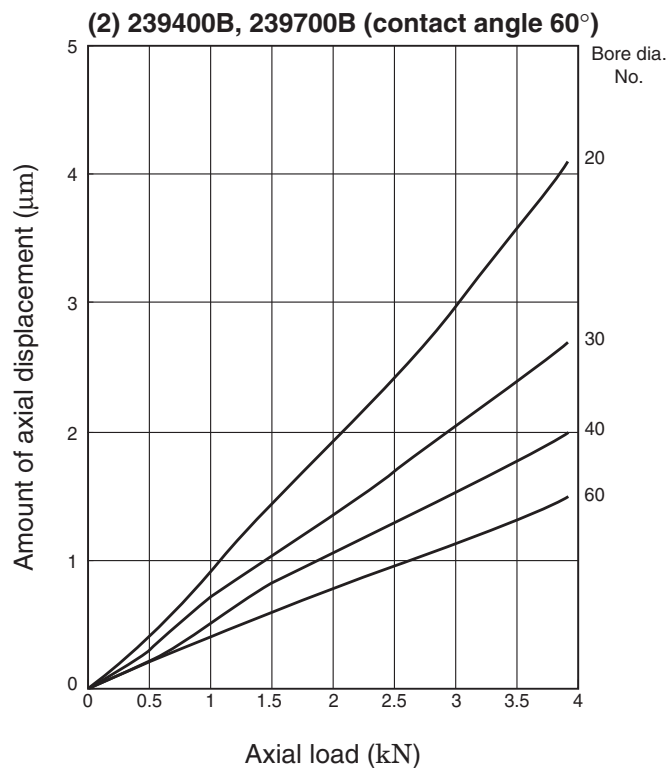
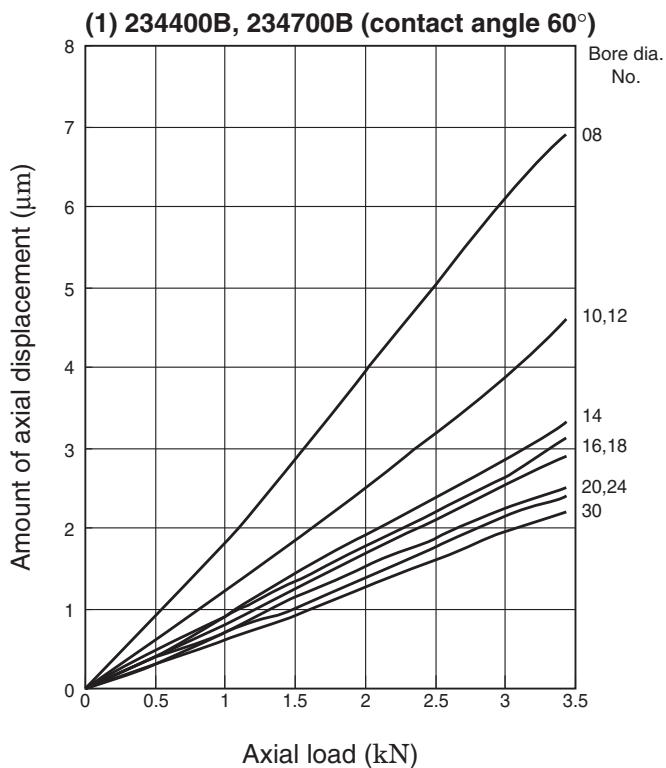

(3) ACT000 (contact angle 30°)

a) When preload L is applied

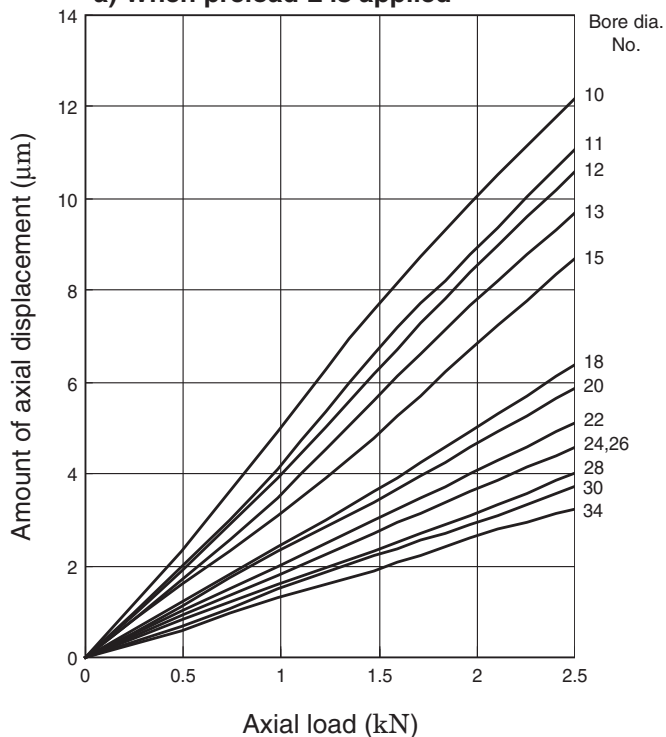

(4) ACT000B (contact angle 40°)

a) When preload L is applied

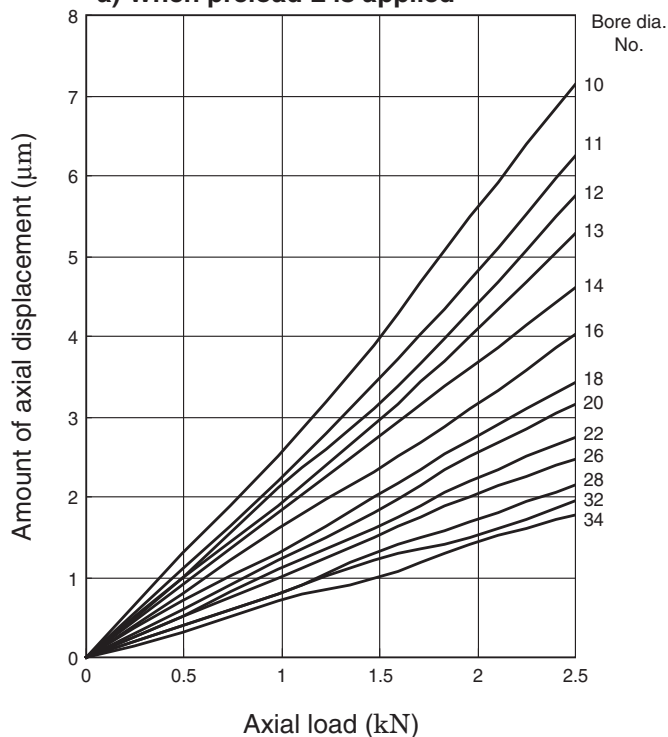

b) When preload M is applied

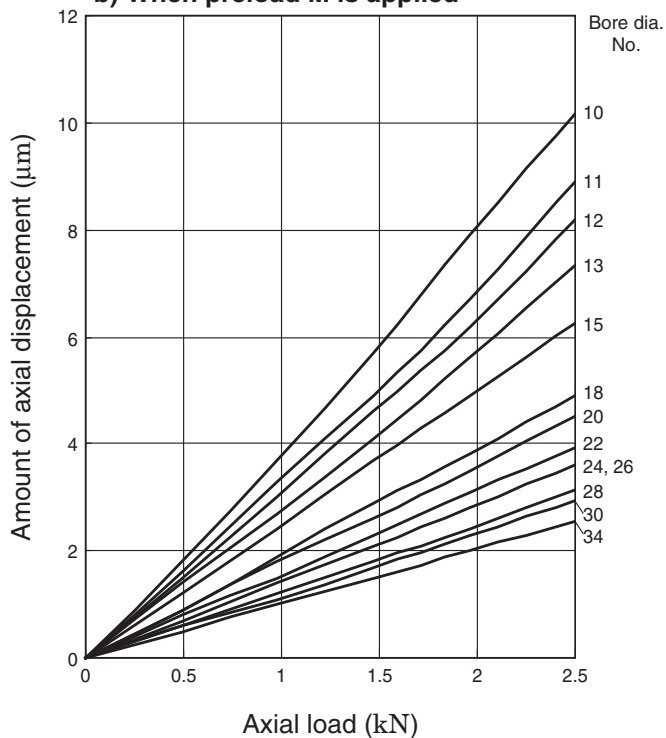

b) When preload M is applied

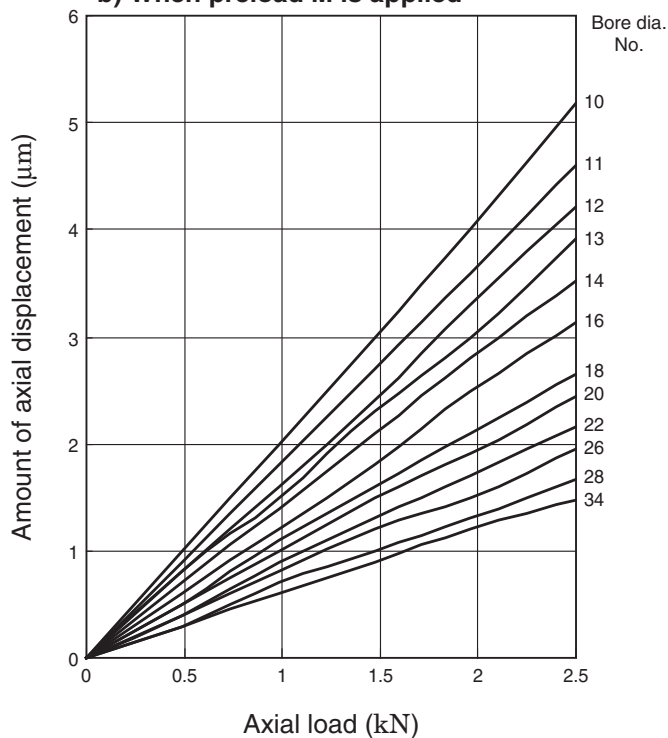

Double direction angular contact thrust ball bearings

d 25 ~ 105 mm

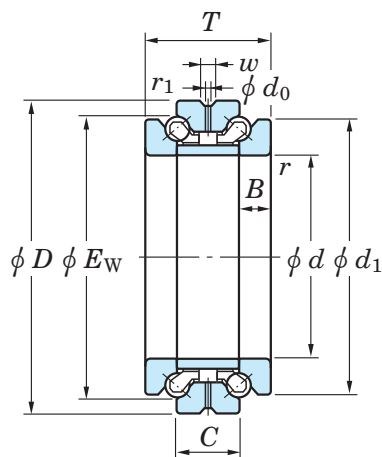

d	Boundary dimensions (mm)						Basic load ratings (kN)		Limiting speeds (min^{-1})		Bearing No.		
	Small bore type	Large bore type	D	T	C	$r_{\text{min.}}$	$r_{1\text{ min.}}$	C_a	C_{0a}	Grease lub.	Oil lub.	Small bore type	Large bore type
25	—	—	47	28	14	0.6	0.3	13.2	19.9	7 700	11 000	234405B	—
30	—	32	55	32	16	1	0.6	14.0	23.6	6 700	9 500	234406B	234706B
35	—	37	62	34	17	1	0.6	20.8	34.8	6 100	8 700	234407B	234707B
40	—	42	68	36	18	1	0.6	23.9	41.7	5 700	8 100	234408B	234708B
45	—	47	75	38	19	1	0.6	26.0	50.1	5 200	7 500	234409B	234709B
50	—	52	80	38	19	1	0.6	26.8	54.4	5 100	7 300	234410B	234710B
55	—	57	90	44	22	1.1	0.6	37.2	71.7	4 400	6 400	234411B	234711B
60	—	62	95	44	22	1.1	0.6	37.6	75.2	4 300	6 200	234412B	234712B
65	—	67	100	44	22	1.1	0.6	39.0	81.8	4 200	6 000	234413B	234713B
70	—	73	110	48	24	1.1	0.6	47.5	103	3 800	5 500	234414B	234714B
75	—	78	115	48	24	1.1	0.6	49.1	111	3 700	5 300	234415B	234715B
80	—	83	125	54	27	1.1	0.6	57.6	132	3 400	4 800	234416B	234716B
85	—	88	130	54	27	1.1	0.6	58.2	137	3 300	4 700	234417B	234717B
90	—	93	140	60	30	1.5	1	67.4	160	3 000	4 300	234418B	234718B
95	—	98	145	60	30	1.5	1	68.0	166	3 000	4 200	234419B	234719B
100	—	140	48	24	1.1	0.6	52.2	135	2 800	3 800	239420B	—	
	103	150	60	30	1.5	1	68.7	172	2 900	4 100	234420B	234720B	
105	—	145	48	24	1.1	0.6	53.6	143	2 700	3 800	239421B	—	
	109	160	66	33	2	1	78.8	199	2 700	3 800	234421B	234721B	

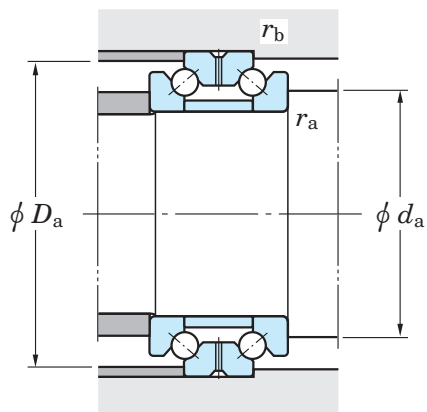

E_w ¹⁾	Dimensions (mm)					Mounting dimensions (mm)				Amount of grease fill (cm ³ /row)	(Refer.) Mass (kg)	
	d_1	B	d_0	w	d_a min.	D_a max.	r_a max.	r_b max.	Small bore type		Large bore type	
41.3	40	7	2	4.5	33	44	0.6	0.3	0.18 ~ 0.26	0.194	—	
48.5	47	8	2	4.5	40	50.5	1	0.6	0.30 ~ 0.45	0.296	0.272	
55	53	8.5	2	4.5	45.5	57.5	1	0.6	0.40 ~ 0.60	0.388	0.357	
61	58.5	9	2	4.5	50	63.5	1	0.6	0.50 ~ 0.75	0.475	0.437	
67.5	65	9.5	2	4.5	56.5	70.5	1	0.6	0.65 ~ 0.98	0.602	0.554	
72.5	70	9.5	2	4.5	61.5	75.5	1	0.6	0.70 ~ 1.1	0.654	0.602	
81	78	11	4	8	67.5	84	1	0.6	1.0 ~ 1.5	0.978	0.900	
86.1	83	11	4	8	72.5	89	1	0.6	1.1 ~ 1.7	1.04	0.957	
91	88	11	4	8	77.5	94	1	0.6	1.2 ~ 1.7	1.11	1.02	
100	97	12	4	8	85	104	1	0.6	1.7 ~ 2.5	1.52	1.40	
105	102	12	4	8	90	109	1	0.6	1.8 ~ 2.6	1.62	1.49	
113	110	13.5	4	8	96.5	119	1	0.6	2.4 ~ 3.6	2.19	2.03	
118	115	13.5	4	8	102	124	1	0.6	2.5 ~ 3.8	2.30	2.12	
127	123	15	4	8	109	133.5	1.5	1	3.3 ~ 4.9	3.03	2.79	
132	128	15	4	8	114	138.5	1.5	1	3.4 ~ 5.0	3.17	2.92	
131	126	12	4	8	114	134	1	0.6	3.1 ~ 4.6	2.08	—	
137	133	15	4	8	119	143.5	1.5	1	3.4 ~ 5.1	3.33	3.06	
136	131	12	4	8	119	139	1	0.6	3.1 ~ 4.6	2.16	—	
146	142	16.5	6	12	127	152	2	1	4.7 ~ 7.1	4.15	3.82	

[Note] 1) The dimension E_w is used as a reference for the ball set outside diameter.

Double direction angular contact thrust ball bearings

d 110 ~ (240) mm

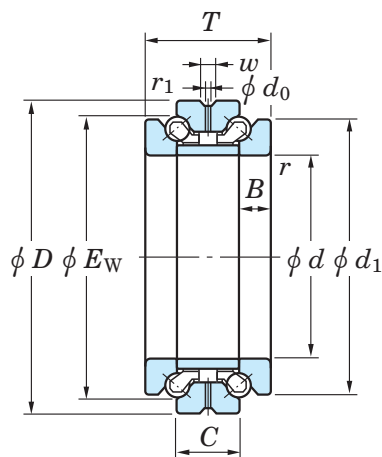

d	Boundary dimensions (mm)						Basic load ratings (kN)		Limiting speeds (min^{-1})		Bearing No.	
	Small bore type	Large bore type	D	T	C	r min.	r_1 min.	C_a	C_{0a}	Grease lub.	Oil lub.	Small bore type
110	—	150	48	24	1.1	0.6	53.9	148	2 700	3 700	239422B	—
	114	170	72	36	2	1	95.9	235	2 500	3 500	234422B	234722B
120	124	165	54	27	1.1	0.6	64.9	185	2 400	3 300	239424B	239724B
	124	180	72	36	2	1	98.3	252	2 400	3 400	234424B	234724B
130	134	180	60	30	1.5	1	75.0	217	2 100	3 000	239426B	239726B
	135	200	84	42	2	1	139	340	2 100	3 000	234426B	234726B
140	144	190	60	30	1.5	1	75.9	229	2 100	2 900	239428B	239728B
	145	210	84	42	2	1	144	366	2 000	2 900	234428B	234728B
150	155	210	72	36	2	1	107	312	1 800	2 500	239430B	239730B
	155	225	90	45	2.1	1.1	147	394	1 900	2 700	234430B	234730B
160	165	220	72	36	2	1	109	329	1 700	2 400	239432B	239732B
	165	240	96	48	2.1	1.1	173	460	1 700	2 500	234432B	234732B
170	175	230	72	36	2	1	111	346	1 700	2 300	239434B	239734B
	176	260	108	54	2.1	1.1	203	547	1 600	2 200	234434B	234734B
180	186	250	84	42	2	1	157	460	1 500	2 100	239436B	239736B
	187	280	120	60	2.1	1.1	234	642	1 400	2 000	234436B	234736B
190	196	260	84	42	2	1	157	474	1 400	2 000	239438B	239738B
	197	290	120	60	2.1	1.1	237	665	1 400	1 900	234438B	234738B
200	207	280	96	48	2.1	1.1	185	557	1 300	1 800	239440B	239740B
	207	310	132	66	2.1	1.1	279	771	1 200	1 800	234440B	234740B
220	227	300	96	48	2.1	1.1	191	606	1 200	1 700	239444B	239744B
	228	340	144	72	3	1.1	334	939	1 100	1 600	234444B	234744B
240	247	320	96	48	2.1	1.1	196	655	1 200	1 600	239448B	239748B

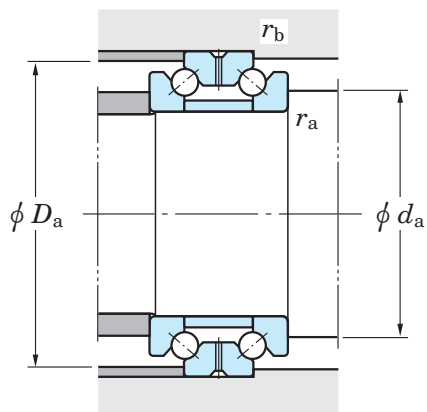

	Dimensions (mm)					Mounting dimensions (mm)				Amount of grease fill (cm ³ /row)	(Refer.) Mass (kg)	
	E_w ¹⁾	d_1	B	d_0	w	d_a min.	D_a max.	r_a max.	r_b max.		Small bore type	Large bore type
	141	136	12	4	8	124	144	1	0.6	3.0 ~ 4.5	2.25	—
	155	150	18	6	12	133	162	2	1	5.9 ~ 8.8	5.38	4.95
	154.5	150	13.5	4	8	138	160	1	0.6	4.2 ~ 6.3	3.12	2.81
	165	160	18	6	12	143	172	2	1	6.4 ~ 9.5	5.77	5.31
	168	163	15	4	8	150	172	1.5	1	5.8 ~ 8.7	4.19	3.77
	182	177	21	6	12	155	192	2	1	9.3 ~ 13.9	8.63	7.94
	178	173	15	4	8	160	182	1.5	1	6.3 ~ 9.4	4.47	4.03
	192	187	21	6	12	165	202	2	1	9.7 ~ 14.5	9.18	8.44
	196.5	190	18	4	8	174	200	2	1	9.6 ~ 14.4	7.01	6.31
	206	200	22.5	6	14	178	215	2	1	12.0 ~ 17.9	11.3	10.4
	206.5	200	18	4	8	184	210	2	1	9.3 ~ 14.0	7.40	6.66
	219	212	24	6	14	189	230	2	1	14.1 ~ 21.1	13.3	12.2
	216.5	210	18	4	8	194	220	2	1	10.8 ~ 16.2	7.79	7.01
	236	230	27	6	14	203	250	2	1	18.6 ~ 27.8	18.1	16.6
	234	227	21	4	8	207	240	2	1	14.9 ~ 22.3	11.3	10.2
	255	248	30	8	16	219	270	2	1	23.4 ~ 35.1	24.9	22.9
	242	237	21	4	8	217	250	2	1	15.7 ~ 23.5	11.9	10.7
	265	258	30	8	16	229	280	2	1	24.7 ~ 37.1	25.0	23.0
	259	252	24	4	8	231	268	2	1	23.5 ~ 35.2	16.6	14.9
	282	274	33	8	16	243	300	2	1	31.8 ~ 47.7	32.1	29.5
	280	272	24	6	12	251	288	2	1	24.7 ~ 37.0	18.0	16.2
	310	304	36	12	22	267	330	2.5	1	43.0 ~ 64.4	42.0	38.6
	299	292	24	6	12	271	308	2	1	26.4 ~ 39.5	19.1	17.2

[Note] 1) The dimension E_w is used as a reference for the ball set outside diameter.

Double direction angular contact thrust ball bearings

d (240) ~ 340 mm

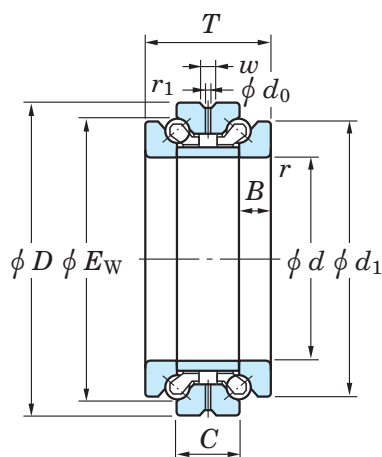

d	Boundary dimensions (mm)						Basic load ratings (kN)		Limiting speeds (min^{-1})		Bearing No.	
	Small bore type	Large bore type	D	T	C	$r_{\text{min.}}$	$r_{1\text{ min.}}$	C_a	C_{0a}	Grease lub.	Oil lub.	Small bore type
240	248	360	144	72	3	1.1	342	1 010	1 100	1 500	234448B	234748B
	269	400	164	82	4	1.5	406	1 270	920	1 300	234452B	234752B
260	269	380	120	60	2.1	1.1	265	915	910	1 300	239456B	239756B
	289	420	164	82	4	1.5	417	1 360	880	1 300	234456B	234756B
280	310	420	144	72	3	1.1	352	1 150	770	1 100	239460B	239760B
	310	460	190	95	4	1.5	476	1 630	760	1 100	234460B	234760B
300	330	440	144	72	3	1.1	361	1 220	740	1 000	239464B	239764B
	330	480	190	95	4	1.5	479	1 680	730	1 000	234464B	234764B
320	—	460	144	72	3	1.1	368	1 290	710	980	239468B	—

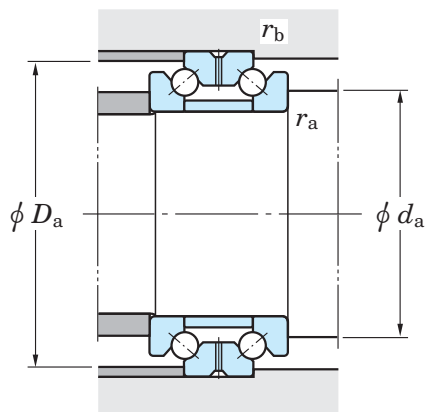

	Dimensions (mm)					Mounting dimensions (mm)				Amount of grease fill (cm ³ /row)	(Refer.) Mass (kg)	
	E_w ¹⁾	d_1	B	d_0	w	d_a min.	D_a max.	r_a max.	r_b max.		Small bore type	Large bore type
	330	322	36	12	22	287	350	2.5	1	47.7 ~ 71.6	45.0	41.4
	335	328	30	6	12	299	344	2	1	43.7 ~ 65.5	33.5	30.2
	364	354	41	12	22	315	388	3	1.5	67.0 ~ 101	65.8	60.5
	356	348	30	6	14	319	363	2	1	49.1 ~ 73.7	35.7	32.1
	384	374	41	12	22	335	408	3	1.5	73.5 ~ 110	69.8	64.2
	391	384	36	6	14	349	398	2.5	1	71.5 ~ 107	56.1	50.5
	418	406	47.5	12	22	364	448	3	1.5	98.0 ~ 147	100	91.8
	408	404	36	6	14	369	419	2.5	1	81.5 ~ 122	59.2	53.3
	438	426	47.5	12	22	384	468	3	1.5	108 ~ 162	106	97.5
	428	424	36	8	16	389	438	2.5	1	84.5 ~ 127	63.1	—

[Note] 1) The dimension E_w is used as a reference for the ball set outside diameter.

Matched pair angular contact ball bearings

d 30 ~ 85 mm

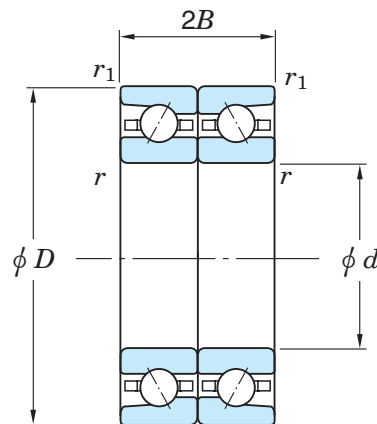

d	Boundary dimensions (mm)				Basic load ratings (kN)		Limiting speeds (min^{-1})		
	D	$2B$	r min.	r_1 min.	C_a	C_{0a}	Grease lub.	Oil lub.	
30	55	24	1	0.6	15.1	26.6	15 000	20 000	
	55	24	1	0.6	18.1	30.5	13 000	18 000	
35	62	25.5	1	0.6	15.8	30.2	13 000	17 000	
	62	25.5	1	0.6	18.9	34.5	12 000	15 000	
40	68	27	1	0.6	16.5	33.8	12 000	15 000	
	68	27	1	0.6	19.6	37.7	11 000	14 000	
45	75	28.5	1	0.6	18.4	38.6	11 000	14 000	
	75	28.5	1	0.6	21.8	42.7	9 500	13 000	
50	80	28.5	1	0.6	19.1	41.7	9 700	13 000	
	80	28.5	1	0.6	22.7	46.3	8 800	12 000	
55	90	33	1.1	0.6	23.7	52.8	8 700	11 000	
	90	33	1.1	0.6	28.1	58.6	7 900	10 000	
60	95	33	1.1	0.6	24.6	56.9	8 100	11 000	
	95	33	1.1	0.6	29.1	63.1	7 400	9 700	
65	100	33	1.1	0.6	25.4	60.9	7 600	10 000	
	100	33	1.1	0.6	30.1	67.6	6 900	9 000	
70	110	36	1.1	0.6	34.8	82.1	7 000	9 200	
	110	36	1.1	0.6	41.3	91.1	6 300	8 300	
75	115	36	1.1	0.6	35.3	84.9	6 600	8 700	
	115	36	1.1	0.6	41.8	94.2	6 000	7 800	
80	125	40.5	1.1	0.6	41.3	101	6 100	8 000	
	125	40.5	1.1	0.6	49.1	112	5 500	7 200	
85	130	40.5	1.1	0.6	41.9	105	5 800	7 600	
	130	40.5	1.1	0.6	49.7	116	5 200	6 900	

[Note] 1) B and no indication before matching code in bearing numbers represent nominal contact angle of 40° and 30° respectively.

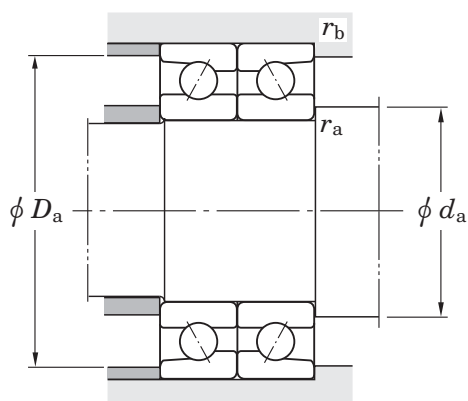

Bearing No. ¹⁾	Permissible axial loads (kN) (static)	Mounting dimensions (mm)				Envelope volume (cm ³ /row)	(Refer.) Mass (kg/row)
		d_a min.	D_a max.	r_a max.	r_b max.		
ACT006DB ACT006BDB	2.92 9.86	41 41	50 50	1 1	0.6 0.6	3.0 3.0	0.235 0.235
ACT007DB ACT007BDB	3.25 10.9	46 46	57 57	1 1	0.6 0.6	4.2 4.2	0.312 0.312
ACT008DB ACT008BDB	3.58 12.1	51 51	63 63	1 1	0.6 0.6	5.0 5.0	0.391 0.391
ACT009DB ACT009BDB	3.84 13.2	56 56	70 70	1 1	0.6 0.6	5.7 5.7	0.536 0.536
ACT010DB ACT010BDB	4.20 14.5	61 61	75 75	1 1	0.6 0.6	8.0 8.0	0.551 0.551
ACT011DB ACT011BDB	5.63 19.0	68 68	84 84	1 1	0.6 0.6	12 12	0.831 0.831
ACT012DB ACT012BDB	6.11 20.6	73 73	89 89	1 1	0.6 0.6	13 13	0.887 0.887
ACT013DB ACT013BDB	6.59 22.2	78 78	94 94	1 1	0.6 0.6	14 14	0.943 0.945
ACT014DB ACT014BDB	8.39 28.8	85 85	104 104	1 1	0.6 0.6	16 16	1.33 1.33
ACT015DB ACT015BDB	8.74 30.0	90 90	109 109	1 1	0.6 0.6	20 20	1.35 1.35
ACT016DB ACT016BDB	10.8 36.6	97 97	118 118	1 1	0.6 0.6	27 27	1.86 1.86
ACT017DB ACT017BDB	11.2 38.0	102 102	123 123	1 1	0.6 0.6	29 29	1.94 1.94

Matched pair angular contact ball bearings

d 90 ~ 180 mm

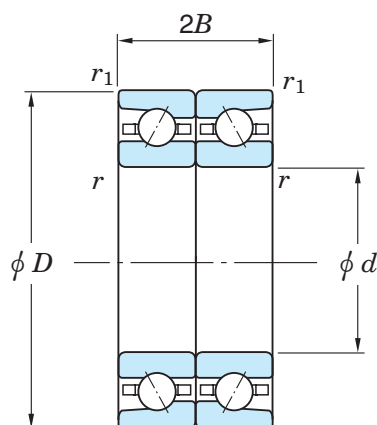

d	Boundary dimensions (mm)				Basic load ratings (kN)		Limiting speeds (min ⁻¹)		
	D	$2B$	r min.	r_1 min.	C_a	C_{0a}	Grease lub.	Oil lub.	
90	140	45	1.5	1	55.0	138	5 400	7 100	
	140	45	1.5	1	65.3	153	4 900	6 400	
95	145	45	1.5	1	55.8	143	5 200	6 800	
	145	45	1.5	1	66.3	159	4 700	6 200	
100	150	45	1.5	1	56.6	148	5 000	6 500	
	150	45	1.5	1	67.2	164	4 500	5 900	
105	160	49.5	2	1	64.4	170	4 700	6 100	
	160	49.5	2	1	76.4	188	4 200	5 500	
110	170	54	2	1	72.4	193	4 400	5 800	
	170	54	2	1	86.0	214	4 000	5 200	
120	180	54	2	1	74.6	206	4 100	5 400	
	180	54	2	1	88.4	228	3 700	4 900	
130	200	63	2	1	94.2	253	3 700	4 800	
	200	63	2	1	112	281	3 300	4 400	
140	210	63	2	1	102	290	3 400	4 500	
	210	63	2	1	121	323	3 100	4 100	
150	225	67.5	2.1	1.1	120	344	3 200	4 200	
	225	67.5	2.1	1.1	143	382	2 900	3 800	
160	240	72	2.1	1.1	130	377	3 000	3 900	
	240	72	2.1	1.1	155	419	2 700	3 500	
170	260	81	2.1	1.1	153	449	2 700	3 600	
	260	81	2.1	1.1	181	499	2 500	3 200	
180	280	90	2.1	1.1	173	510	2 500	3 300	
	280	90	2.1	1.1	205	566	2 300	3 000	

[Note] 1) B and no indication before matching code in bearing numbers represent nominal contact angle of 40° and 30° respectively.

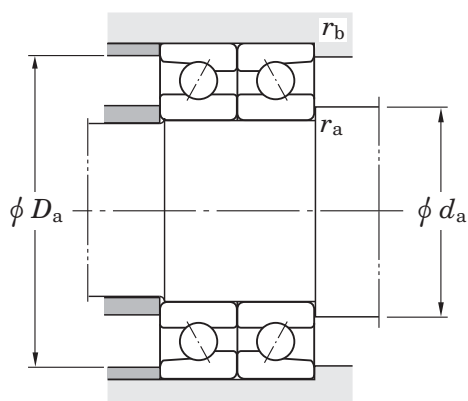

Bearing No. ¹⁾	Permissible axial loads (kN) (static)	Mounting dimensions (mm)				Envelope volume (cm ³ /row)	(Refer.) Mass (kg/row)
		d_a min.	D_a max.	r_a max.	r_b max.		
ACT018DB ACT018BDB	14.2 48.7	109	132	1.5	1	39	2.55
ACT019DB ACT019BDB	14.8 50.6	114	137	1.5	1	40	2.62
ACT020DB ACT020BDB	15.3 52.5	119	143	1.5	1	42	2.77
ACT021DB ACT021BDB	18.2 63.2	125	151	2	1	50	3.61
ACT022DB ACT022BDB	19.6 71.3	132	160	2	1	64	4.52
ACT024DB ACT024BDB	21.0 76.4	142	170	2	1	69	4.83
ACT026DB ACT026BDB	25.9 93.0	156	188	2	1	106	7.21
ACT028DB ACT028BDB	29.9 107	166	198	2	1	110	7.69
ACT030DB ACT030BDB	34.7 125	178	213	2	1	138	9.39
ACT032DB ACT032BDB	39.1 139	190	227	2	1	167	11.4
ACT034DB ACT034BDB	45.7 163	204	245	2	1	221	15.7
ACT036DB ACT036BDB	54.0 183	216	264	2	1	313	22.2

Matched pair angular contact ball bearings

d 190 ~ 320 mm

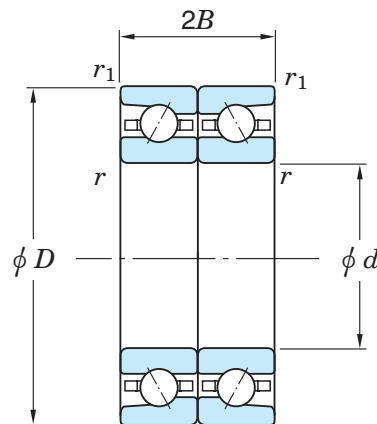

d	Boundary dimensions (mm)				Basic load ratings (kN)		Limiting speeds (min ⁻¹)		
	D	$2B$	r min.	r_1 min.	C_a	C_{0a}	Grease lub.	Oil lub.	
190	290	90	2.1	1.1	179	544	2 400	3 100	
	290	90	2.1	1.1	213	604	2 200	2 800	
200	310	99	2.1	1.1	215	633	2 200	2 900	
	310	99	2.1	1.1	255	702	2 000	2 600	
220	340	108	3	1.1	252	773	2 000	2 600	
	340	108	3	1.1	299	858	1 800	2 400	
240	360	108	3	1.1	260	823	1 800	2 400	
	360	108	3	1.1	308	914	1 600	2 200	
260	400	123	4	1.5	321	1 090	1 600	2 100	
	400	123	4	1.5	381	1 210	1 500	1 900	
280	420	123	4	1.5	332	1 160	1 500	2 000	
	420	123	4	1.5	393	1 290	1 400	1 800	
300	460	142.5	4	1.5	375	1 370	1 300	1 800	
	460	142.5	4	1.5	444	1 530	1 200	1 600	
320	480	142.5	4	1.5	378	1 420	1 200	1 600	
	480	142.5	4	1.5	449	1 570	1 100	1 500	

[Note] 1) B and no indication before matching code in bearing numbers represent nominal contact angle of 40° and 30° respectively.

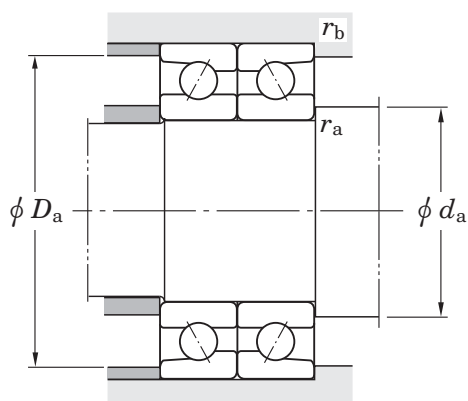

Bearing No. ¹⁾	Permissible axial loads (kN) (static)	Mounting dimensions (mm)				Envelope volume (cm ³ /row)	(Refer.) Mass (kg/row)
		d_a min.	D_a max.	r_a max.	r_b max.		
ACT038DB ACT038BDB	57.9 196	226 226	275 275	2 2	1 1	329 329	23.0 23.0
ACT040DB ACT040BDB	64.8 229	240 240	293 293	2 2	1 1	421 421	29.5 29.5
ACT044DB ACT044BDB	81.9 278	263 263	321 321	2.5 2.5	1 1	566 566	38.5 38.5
ACT048DB ACT048BDB	87.9 298	283 283	343 343	2.5 2.5	1 1	605 605	41.1 41.1
ACT052DB ACT052BDB	111 393	310 310	379 379	3 3	1.5 1.5	866 866	60.5 60.5
ACT056DB ACT056BDB	119 421	330 330	401 401	3 3	1.5 1.5	915 915	64.1 64.1
ACT060DB ACT060BDB	143 501	358 358	435 435	3 3	1.5 1.5	1 320 1 320	92.1 92.1
ACT064DB ACT064BDB	148 518	378 378	457 457	3 3	1.5 1.5	1 400 1 400	96.9 96.9

KOYO

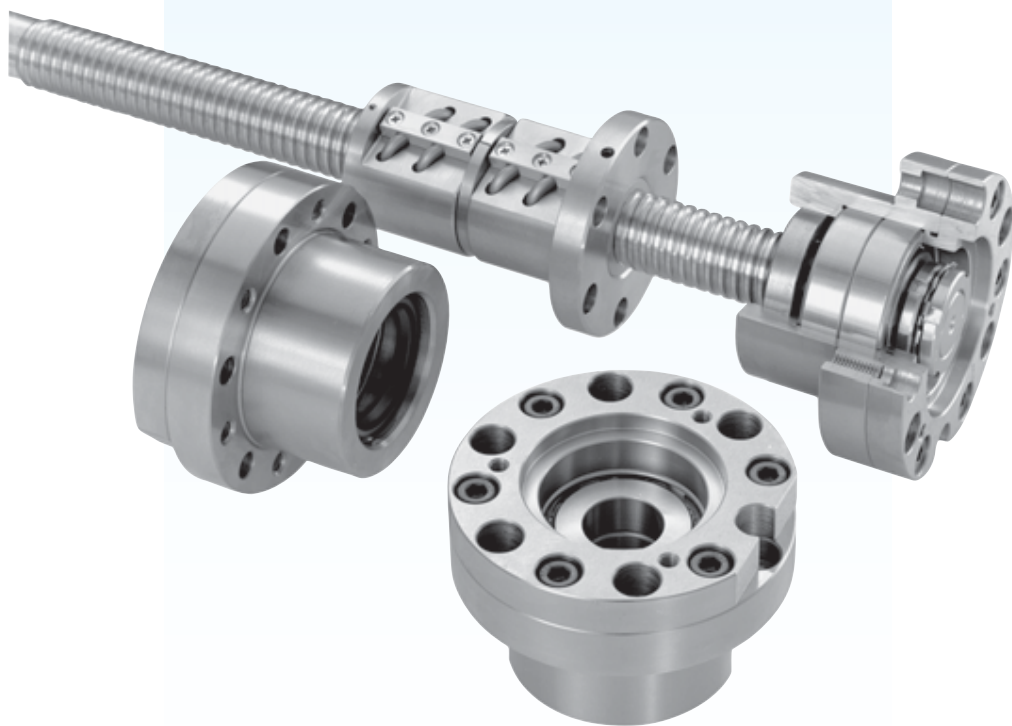

Precision ball screw support bearings and bearing units

■ Support bearings were developed to support precision ball screw shafts. They have the same structure as angular contact thrust ball bearings with a contact angle of 60°.

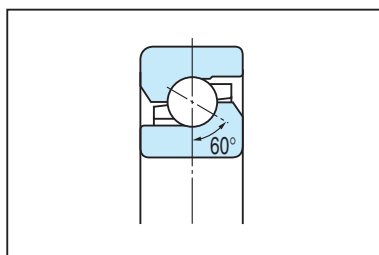

- Have a large axial load carrying capacity. Also able to carry a certain degree of radial load.
- Highly rigid in the axial direction.
- Starting torque is small.

Support bearings

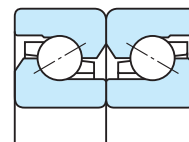

Bore diameter 17 – 60 mm

Support bearing units

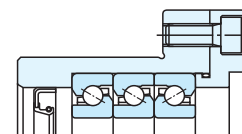

Bore diameter 17 – 40 mm

- Support bearing units consist of the bearings described above and a precisely processed housing. Units with a Koyo precision ball screw are also available.
- For details, refer to JTEKT separate catalog "Precision Ball and Roller Bearings for Machine Tools" (CAT. NO. B2005E).

Table 1 Support bearing tolerance

(1) Inner ring

Unit : μm

Nominal bore diameter d (mm)		Single plane mean bore diameter deviation Δ_{dmp}				Single bore diameter deviation Δ_{ds}				Single inner ring width deviation Δ_{Bs}		Inner ring width variation V_{Bs}		Radial runout of assembled bearing inner ring K_{ia}		Perpendicularity of inner ring face with respect to the bore S_d		Assembled bearing inner ring face runout with raceway S_{ia}	
		class 5Z		class 4Z		class 5Z		class 4Z		classes 5Z, 4Z		class 5Z	class 4Z	class 5Z	class 4Z	class 5Z	class 4Z	class 5Z	class 4Z
over	up to	upper	lower	upper	lower	upper	lower	upper	lower	upper	lower	max.		max.		max.		max.	
10	18	0	-5	0	-4	0	-5	0	-4	0	-80	5	2.5	4	2.5	7	3	5	3
18	30	0	-6	0	-5	0	-6	0	-5	0	-120	5	2.5	4	3	8	4	5	3
30	50	0	-8	0	-6	0	-8	0	-6	0	-120	5	3	5	4	8	4	6	3
50	80	0	-9	0	-7	0	-9	0	-7	0	-150	6	4	5	4	8	5	7	4

(2) Outer ring

Unit : μm

Nominal outside diameter D (mm)		Single plane mean outside diameter deviation Δ_{Dmp}				Single outside diameter deviation Δ_{Ds}				Single outer ring width deviation Δ_{Cs}		Outer ring width variation V_{Cs}		Radial runout of assembled bearing outer ring K_{ea}		Perpendicularity of outer ring outside surface with respect to the face S_D		Assembled bearing outer ring face runout with raceway S_{ea}	
		class 5Z		class 4Z		class 5Z		class 4Z		classes 5Z, 4Z		class 5Z	class 4Z	class 5Z	class 4Z	class 5Z	class 4Z	class 5Z	class 4Z
over	up to	upper	lower	upper	lower	upper	lower	upper	lower	upper	lower	max.		max.		max.		max.	
30	50	0	-7	0	-6	0	-7	0	-6	Equivalent to Δ_{Bs} tolerances of a bearing of the same d		5	2.5	7	5	8	4	Equivalent to S_{ia} tolerances of a bearing of the same d	
50	80	0	-9	0	-7	0	-9	0	-7			6	3	8	5	8	4		
80	120	0	-10	0	-8	0	-10	0	-8			8	4	10	6	9	5		

Precision ball screw support bearings

d 17 ~ 60 mm

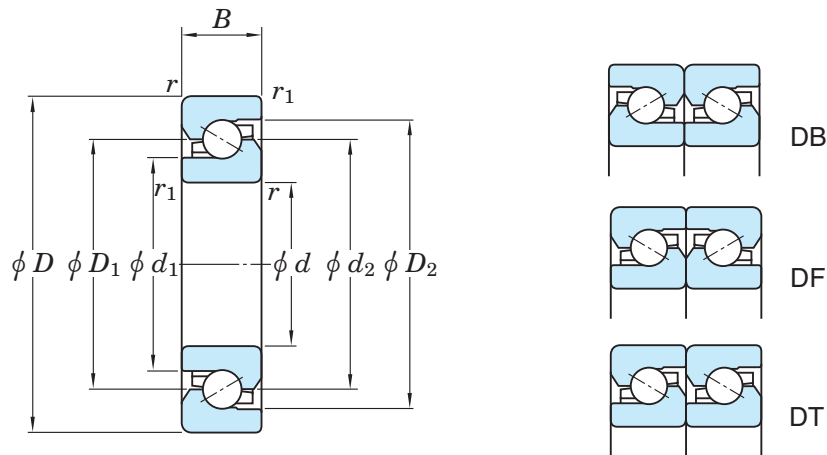

Boundary dimensions (mm)					Basic dynamic load rating ¹⁾ C_a (kN)	Max. axial loadings (kN)			Limiting speeds (min ⁻¹)		Bearing No. ²⁾	Envelope volume (cm ³ /row)
d	D	B	r min.	r_1 min.		Single-row	Double-row	Triple-row	Grease lub.	Oil lub.		
17	47	15	1	0.6	26.0	34.3	68.6	103	6 300	8 000	SAC1747B	3.7
20	47	15	1	0.6	26.0	34.3	68.6	103	6 300	8 000	SAC2047B	3.7
25	62	15	1	0.6	30.2	48.1	96.2	144	4 600	6 000	SAC2562B	4.9
30	62	15	1	0.6	30.2	48.1	96.2	144	4 600	6 000	SAC3062B	4.9
35	72	15	1	0.6	32.8	58.8	118	176	3 700	5 000	SAC3572B	6.2
40	72	15	1	0.6	32.8	58.8	118	176	3 700	4 800	SAC4072B	6.2
	90	20	1	0.6	65.4	122	244	366	3 100	4 000	SAC4090B	15
45	75	15	1	0.6	34.0	64.4	129	193	3 400	4 300	SAC4575B	6.9
	100	20	1	0.6	68.8	137	274	411	2 800	3 600	SAC45100B	16
50	100	20	1	0.6	70.3	144	288	432	2 700	3 400	SAC50100B	17
55	120	20	1	0.6	73.9	166	332	498	2 300	3 000	SAC55120B	20
60	120	20	1	0.6	73.9	166	332	498	2 300	3 000	SAC60120B	20

[Notes] 1) The basic dynamic load ratings of a single-row bearing are shown in this column. Those of matched pair and stack bearings are as shown below.

Number of rows which support axial loading	Basic dynamic load rating	Matching types (the arrow denotes the load direction.)
One	C_a	
Two	$C_a \times 1.625$	
Three	$C_a \times 2.16$	

2) Matched bearing numbers consist of a single-row bearing number and a matching code such as DB or DF which is shown as a suffix.

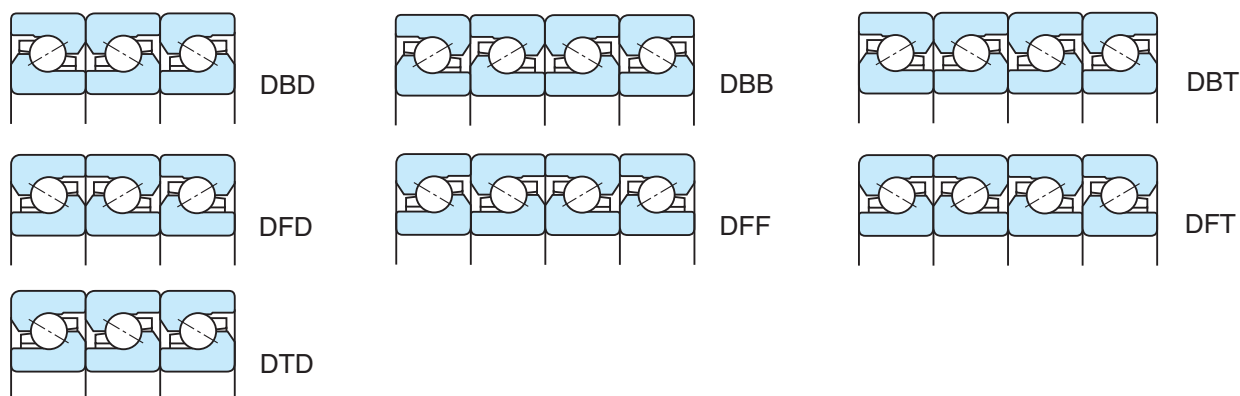

	Dimensions (mm)				Standard preload (kN)			Starting torque (mN·m)			Axial rigidity (N/μm)			(Refer.) Mass (kg/row)
	d_1	d_2	D_1	D_2	Matching types			Matching types			Matching types			
					Two bearings	Three bearings	Four bearings	Two bearings	Three bearings	Four bearings	Two bearings	Three bearings	Four bearings	
	25.5	33.7	33.5	41	2.15	2.92	4.30	140	180	280	695	1 030	1 390	0.13
	26.8	33.7	33.5	41	2.15	2.92	4.30	140	180	280	695	1 030	1 390	0.12
	38	46.2	46	53.5	3.04	4.13	6.08	200	260	400	970	1 440	1 940	0.24
	38	46.2	46	53.5	3.04	4.13	6.08	200	260	400	970	1 440	1 940	0.21
	48	56.3	55.9	63.5	3.73	5.07	7.46	240	320	480	1 180	1 760	2 360	0.29
	48	56.3	55.9	63.5	3.73	5.07	7.46	240	320	480	1 180	1 760	2 360	0.26
	54.5	67.5	66.8	78.5	5.00	6.80	10.0	440	610	880	1 270	1 890	2 540	0.62
	54	61.7	61.5	69	3.89	5.29	7.78	250	330	500	1 270	1 890	2 540	0.25
	61.5	74.2	74	85.5	5.95	8.09	11.9	540	730	1 080	1 450	2 150	2 900	0.79
	65.8	78.2	78	89.5	6.00	8.15	12.0	540	730	1 080	1 500	2 230	3 000	0.65
	79.5	92.2	92	103.6	7.08	9.62	14.2	640	860	1 280	1 740	2 590	3 480	1.15
	78.3	92.2	92	103.6	7.08	9.62	14.2	640	860	1 280	1 740	2 590	3 480	1.15

Dynamic equivalent load $P_a = XF_r + YF_a$

Matching Types	Two bearings		Three bearings			Four bearings			
	DB DF	DT	DBD DFD	DTD	DBT DFT	DBB DFF	DBT DFT		
Number of rows which support axial loading	One	Two	One	Two	Three	One	Two	Three	
$\frac{F_a}{F_r} \leq 2.17$	X	1.9	—	1.43	2.33	—	1.17	2.33	2.53
	Y	0.54	—	0.77	0.35	—	0.89	0.35	0.26
$\frac{F_a}{F_r} > 2.17$	X	0.92							
	Y	1							

Precision ball screw support bearing units

d 17 ~ 40 mm

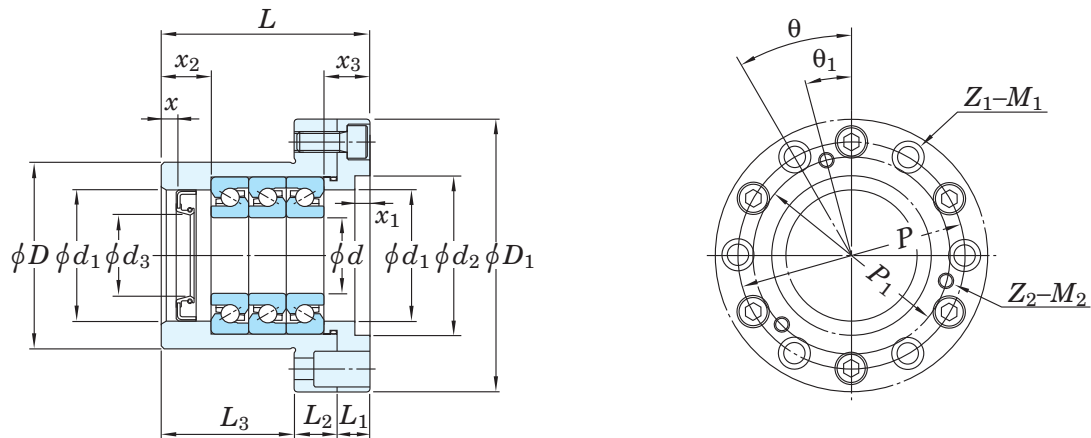

Dimensions (mm)													Applicable shaft dia. d_3 (mm)	Unit No. ¹⁾
d	D	D_1	L	L_1	L_2	L_3	d_1	d_2	x	x_1	x_2	x_3		
17	60	90	65	15	15	35	38	47	6	6	15	20	28	BSU1747BDF
20	60	90	65	15	15	35	38	47	6	6	15	20	28	BSU2047BDF
25	74	108	68	13	17	38	52	63	6	6	20	18	32	BSU2562BDF
	74	108	83	13	17	53	52	63	6	6	20	18	32	BSU2562BDFD
30	74	108	68	13	17	38	52	63	6	6	20	18	40	BSU3062BDF
	74	108	83	13	17	53	52	63	6	6	20	18	40	BSU3062BDFD
35	84	118	68	13	17	38	60	73	6	6	20	18	45	BSU3572BDF
	84	118	83	13	17	53	60	73	6	6	20	18	45	BSU3572BDFD
	84	118	98	13	17	68	60	73	6	6	20	18	45	BSU3572BDFD
40	84	118	68	13	17	38	60	73	6	6	20	18	50	BSU4072BDF
	84	118	83	13	17	53	60	73	6	6	20	18	50	BSU4072BDFD
	84	118	98	13	17	68	60	73	6	6	20	18	50	BSU4072BDFD

[Note] 1) Diagrams show a unit mounted with triple-row matched bearing DFD.
 Specifications of each bearing are shown in the former pages. (BSU1747BDF → SAC1747BDF)

Bearing qty.	Drilled-hole of housing			Tapped-hole for dust-cover			Standard preload (kN)	Starting torque (mN·m)	(Refer.) Mass (kg)
	P (mm)	θ (°)	Z_1 - M_1 Hole No.-thread	P_1 (mm)	θ_1 (°)	Z_2 - M_2 Hole No.-thread			
2	75	45	4-M6	75	22.5	4-M6	2.15	140	1.72
2	75	45	4-M6	75	22.5	4-M6	2.15	140	1.70
2	90	30	6-M8	78	15	3-M6	3.04	200	2.45
3	90	30	6-M8	78	15	3-M6	4.13	260	2.85
2	90	30	6-M8	78	15	3-M6	3.04	200	2.38
3	90	30	6-M8	78	15	3-M6	4.13	260	2.74
2	100	30	6-M8	88	15	3-M6	3.73	240	2.81
3	100	30	6-M8	88	15	3-M6	5.07	320	3.28
4	100	30	6-M8	88	15	3-M6	7.46	480	3.74
2	100	30	6-M8	88	15	3-M6	3.73	240	2.77
3	100	30	6-M8	88	15	3-M6	5.07	320	3.20
4	100	30	6-M8	88	15	3-M6	7.46	480	3.64

[Refer.] Relationship between axial load and axial displacement

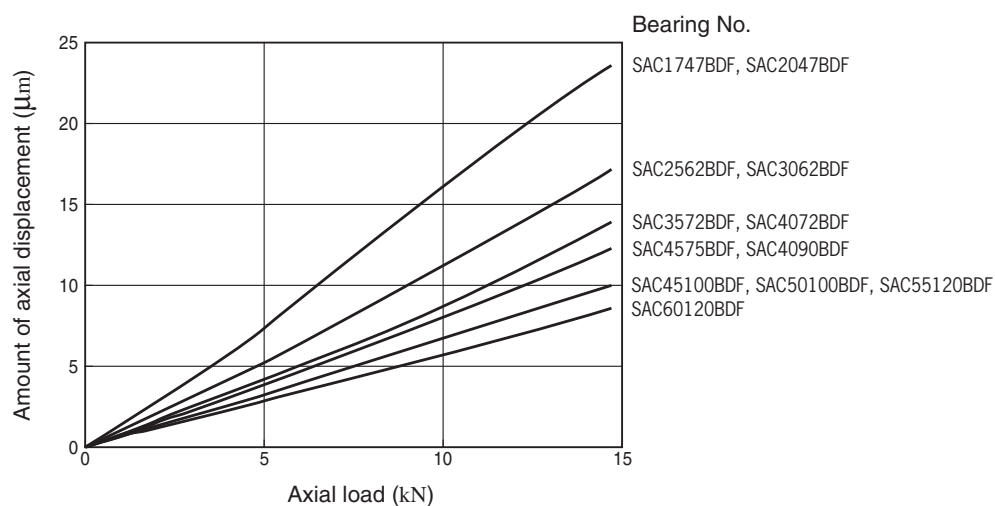

KOYO

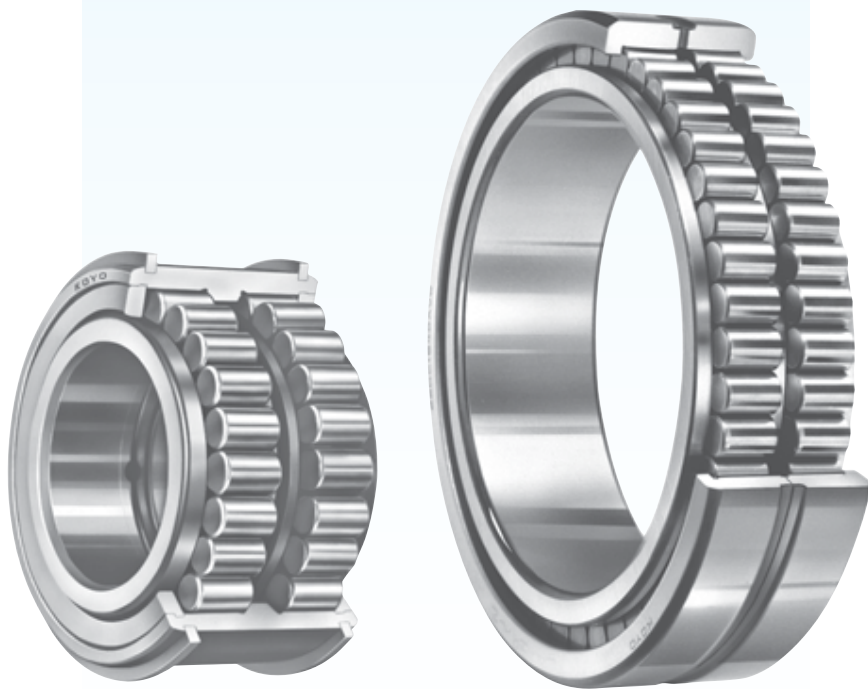

Full complement type cylindrical roller bearings for crane sheaves

Crane rope sheaves and running wheels which are operated at low or medium speed are generally equipped with full complement type cylindrical roller bearings because the operation of these machines involves heavy, impact loading.

These bearings are divided into shielded and open types. The shielded type is often used with the outer ring rotation.

Shielded type

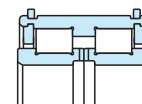

Bore diameter 40 – 440 mm

Open type

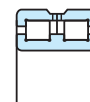

Bore diameter 50 – 440 mm

Shielded type

- The shielded type was developed for use with rope sheaves. It is shielded, non-separable and pre-lubricated with grease.
- Bearings with locating snap rings around the outer ring can be positioned and fit to sheaves with ease.
- The bearing surface is coated with phosphate for rust prevention.

Open type

- Open type bearings are further divided into those used on the fixed side and those used on the free side. The former carry axial load in both directions. The relative position of the latter's inner ring and outer ring can be adjusted by moving them along the axis.
- Open type bearings are separable because the outer ring divided into two annular pieces in a plane perpendicular to its axis. Triple-row and four-row bearings are available along with double-row types.

Tolerances	As specified in JIS B 1514-1, classes 0 and 6 (ref. Table 7-3 on pp. A 54-A 57).				
Recommended fits and radial internal clearance	<ul style="list-style-type: none"> • Recommended fits: refer to Table 9-4 on pp. A 85, 86. <ul style="list-style-type: none"> ■ Fits and clearance of full complement type cylindrical roller bearings for use with crane sheaves with the rotating outer ring load 				
			Shaft tolerance class	Housing bore tolerance class	Bearing radial internal clearance
	Rotating outer ring load	Light or fluctuating load Normal or heavy load Heavy load on thin section housing	g 6 or h 6	M 7 N 7 P 7	CN clearance C3 clearance C3 clearance
	<ul style="list-style-type: none"> • Radial internal clearance : Refer to Table 10-8 (1) on p. A 100. As for the nominal bore dia. up to 140mm shielded type (DC5000 series), the corresponding CN clearance are shown below. <ul style="list-style-type: none"> ■ CN clearance of shielded type roller bearings for nominal diameter up to 140mm 				
Nominal bore dia. d (mm)		CN clearance (μ m)			
over	up to	min.	max.		
30	40	35	70		
40	50	40	75		
50	65	45	90		
65	80	55	105		
80	100	65	115		
100	120	80	120		
120	140	90	130		

Full complement type cylindrical roller bearings for crane sheaves

shielded type

d 40 ~ 150 mm

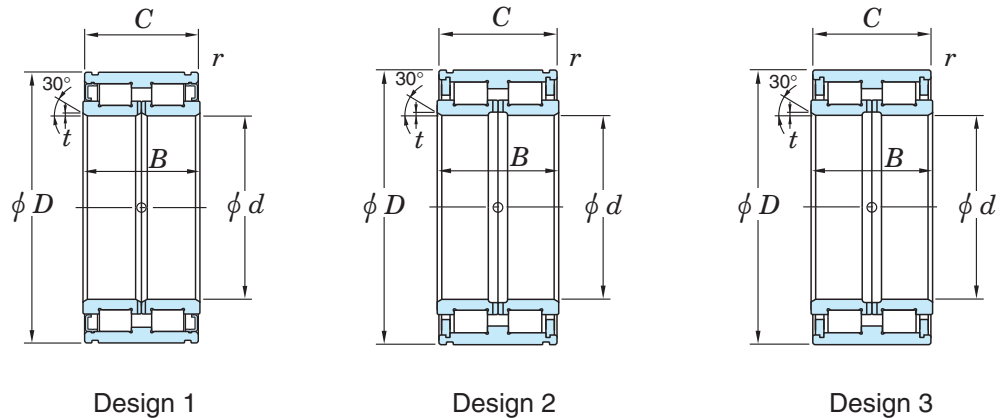

Boundary dimensions (mm)						Basic load ratings (kN)		Bearing No.		Design
d	D	B	C	t	r_{min}	C_r	C_{0r}	Without locating snap rings	With locating snap rings	
40	68	38	37	0.9	0.6	87.8	125	DC5008N	DC5008NR	1
45	75	40	39	0.9	0.6	95.1	144	DC5009N	DC5009NR	1
50	80	40	39	0.9	0.6	99.7	158	DC5010N	DC5010NR	1
55	90	46	45	1.2	0.6	118	193	DC5011N	DC5011NR	1
60	95	46	45	1.2	0.6	123	208	DC5012N	DC5012NR	1
65	100	46	45	1.2	0.6	128	224	DC5013N	DC5013NR	1
70	110	54	53	1.2	0.6	170	285	DC5014N	DC5014NR	1
75	115	54	53	1.2	0.6	178	307	DC5015N	DC5015NR	1
80	125	60	59	1.2	0.6	250	429	DC5016N	DC5016NR	1
85	130	60	59	1.2	0.6	255	446	DC5017N	DC5017NR	1
90	140	67	66	1.4	0.6	303	541	DC5018N	DC5018NR	1
95	145	67	66	1.4	0.6	310	562	DC5019N	DC5019NR	1
100	150	67	66	1.4	0.6	316	584	DC5020N	DC5020NR	1
110	170	80	79	1.7	1	382	697	DC5022N	DC5022NR	1
120	180	80	79	1.7	1	398	750	DC5024N	DC5024NR	1
130	200	95	94	1.7	1	534	1 000	DC5026N	DC5026NR	1
140	210	95	94	1.7	1	540	1 070	DC5028N	DC5028NR	1
150	225	100	99	2	1	682	1 400	DC5030N	DC5030NR	2

- [Notes] 1) Dimensional tolerance of C_1 is $+0.4/0$ when bore diameter is not more than 170mm, while $+0.6/0$ when bore diameter is not more than 170mm.
2) Dimensional tolerance of C_2 is $-0.1/-0.5$ when bore diameter is not more than 170mm, while $-0.1/-0.7$ when bore diameter is not more than 170mm.

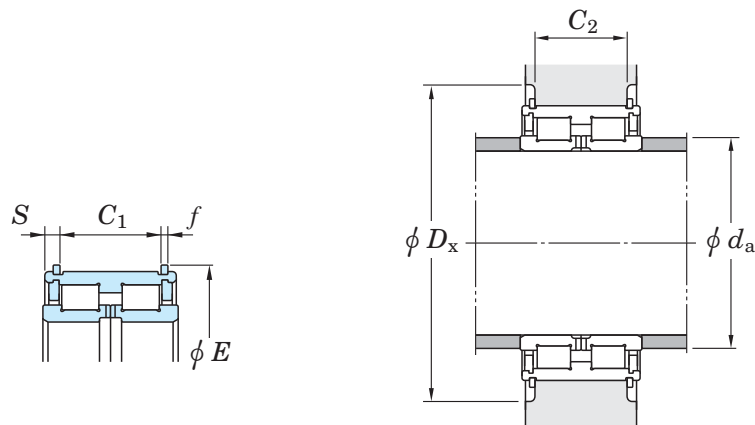

With locating snap rings

	Locating snap ring specifications (mm)				Mounting dimensions (mm)			(Refer.) Mass (kg)
	$C_1^{1)}$	S	E	f	d_a min.	D_x min.	$C_2^{2)}$	
	28	4.5	71.8	2	46	80	28	0.55
	30	4.5	78.8	2	51	87	30	0.70
	30	4.5	83.8	2	56	92	30	0.75
	34	5.5	94.8	2.5	63	104	34	1.19
	34	5.5	99.8	2.5	68	109	34	1.27
	34	5.5	104.8	2.5	73	114	34	1.30
	42	5.5	114.5	2.5	78	124	42	1.94
	42	5.5	119.5	2.5	83	129	42	2.11
	48	5.5	129.5	2.5	88	146	48	2.65
	48	5.5	134.5	2.5	93	155	48	2.80
	54	6	145.4	2.5	100	165	54	3.70
	54	6	150.4	2.5	105	175	54	3.90
	54	6	155.4	2.5	110	180	54	4.05
	65	7	175.4	2.5	122	200	65	6.50
	65	7	188.4	3	132	210	65	6.95
	77	8.5	208.4	3	142	230	77	10.5
	77	8.5	218.4	3	152	245	77	11.0
	81	9	233	3	178.5	244	81	13.9

Full complement type cylindrical roller bearings for crane sheaves

shielded type

d 160 ~ 440 mm

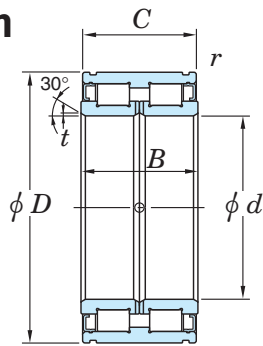

Design 1

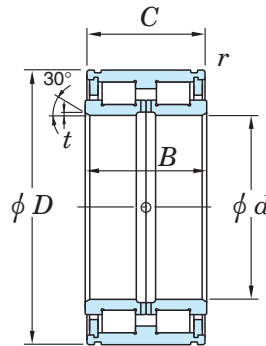

Design 2

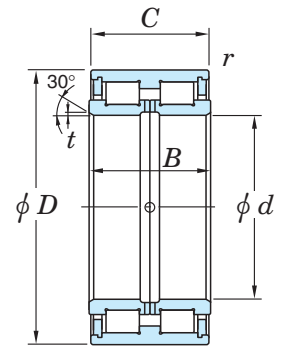

Design 3

Boundary dimensions (mm)						Basic load ratings (kN)		Bearing No.		Design
d	D	B	C	t	$r_{\text{min.}}$	C_r	C_{0r}	Without locating snap rings	With locating snap rings	
160	240	109	108	2	1.1	786	1 640	DC5032N	DC5032NR	2
170	260	122	121	2	1.1	977	2 020	DC5034N	DC5034NR	2
180	280	136	135	2	1.1	1 150	2 440	DC5036N	DC5036NR	2
190	290	136	135	2	1.1	1 180	2 530	DC5038N	DC5038NR	2
200	310	150	149	2	1.1	1 390	2 980	DC5040N	DC5040NR	2
220	340	160	159	2.5	1.1	1 620	3 590	DC5044N	DC5044NR	2
240	360	160	159	2.5	1.1	1 690	3 850	DC5048N	DC5048NR	2
260	400	190	189	3	1.5	2 230	4 980	DC5052N	DC5052NR	2
280	420	190	189	3	1.5	2 330	5 350	DC5056N	DC5056NR	2
300	460	218	216	3	1.5	2 860	6 610	DC5060	—	3
320	480	218	216	3	1.5	2 950	6 930	DC5064	—	3
340	520	243	241	3.5	2	3 590	8 420	DC5068	—	3
360	540	243	241	3.5	2	3 660	8 720	DC5072	—	3
380	560	243	241	3.5	2	3 730	9 020	DC5076	—	3
400	600	272	270	3.5	2	4 510	11 000	DC5080	—	3
420	620	272	270	3.5	2	4 650	11 400	DC5084	—	3
440	650	280	278	4.5	3	4 940	12 200	DC5088	—	3

- [Notes] 1) Dimensional tolerance of C_1 is +0.4/0 when bore diameter is not more than 170mm, while +0.6/0 when bore diameter is not more than 170mm.
2) Dimensional tolerance of C_2 is -0.1/-0.5 when bore diameter is not more than 170mm, while -0.1/-0.7 when bore diameter is not more than 170mm.

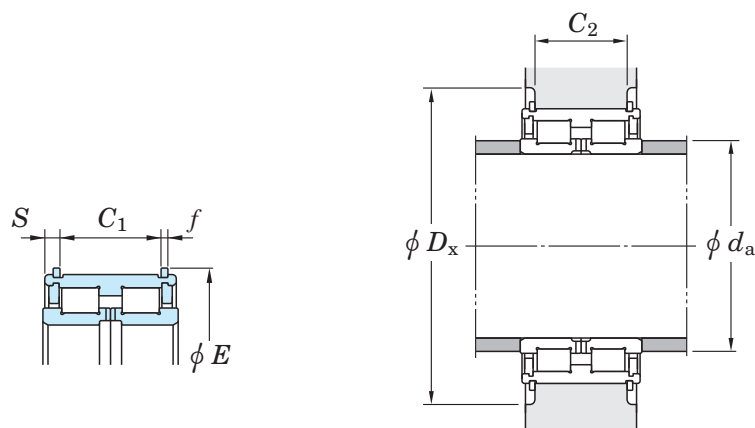

With locating snap rings

	Locating snap ring specifications (mm)				Mounting dimensions (mm)			(Refer.) Mass (kg)
	$C_1^{1)}$	S	E	f	d_a min.	D_x min.	$C_2^{2)}$	
	89	9.5	248	3	190	259	89	17.2
	99	11	270	4	204	286	99	23.1
	110	12.5	290	4	217.5	306	110	30.8
	110	12.5	300	4	225	316	110	32.4
	120	14.5	320	4	240	336	120	41.7
	130	14.5	356	6	266.5	380	130	53.5
	130	14.5	376	6	284.5	400	130	57.3
	154	17.5	416	7	312.5	444	154	87.2
	154	17.5	436	7	334.5	464	154	93.0
	—	—	—	—	361	—	—	134
	—	—	—	—	378.5	—	—	140
	—	—	—	—	413	—	—	189
	—	—	—	—	427	—	—	197
	—	—	—	—	441	—	—	207
	—	—	—	—	475.5	—	—	281
	—	—	—	—	496	—	—	290
	—	—	—	—	521	—	—	330

Full complement type cylindrical roller bearings for crane sheaves

open type

d 50 ~ 200 mm

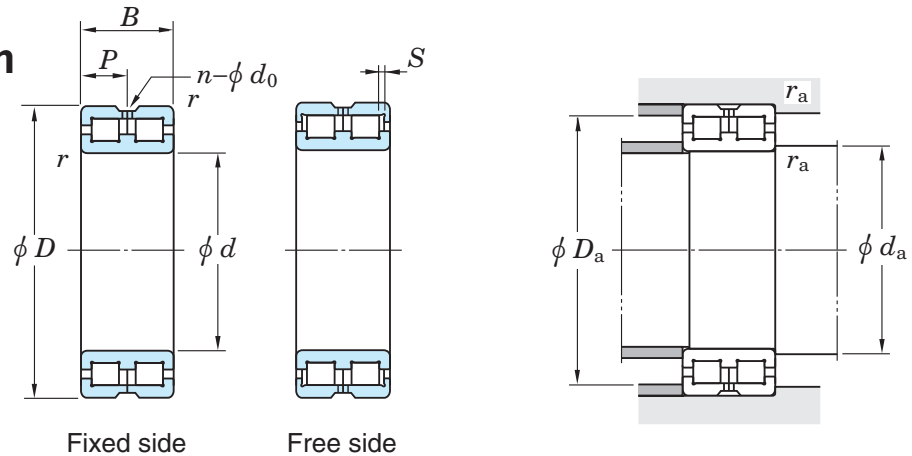

Boundary dimensions (mm)				$S^{1)}$ (mm)	Basic load ratings (kN)		Bearing No.	
d	D	B	r min.		C_r	C_{0r}	Fixed side	Free side
50	72	22	0.6	1	49.1	82.9	DC4910AVW	DC4910VW
60	85	25	1	1	72.7	136	DC4912AVW	DC4912VW
70	100	30	1	1	105	193	DC4914AVW	DC4914VW
80	110	30	1	1	114	218	DC4916AVW	DC4916VW
90	125	35	1.1	1.5	150	301	DC4918AVW	DC4918VW
100	140	40	1.1	2	194	400	DC4920AVW	DC4920VW
110	150	40	1.1	2	202	431	DC4922AVW	DC4922VW
120	165	45	1.1	3	226	479	DC4924AVW	DC4924VW
130	180	50	1.5	4	276	560	DC4926AVW	DC4926VW
140	190	50	1.5	4	284	589	DC4928AVW	DC4928VW
150	190	40	1.1	2	234	575	DC4830AVW	DC4830VW
	210	60	2	4	406	842	DC4930AVW	DC4930VW
160	200	40	1.1	2	242	616	DC4832AVW	DC4832VW
	220	60	2	4	428	895	DC4932AVW	DC4932VW
170	215	45	1.1	3	269	655	DC4834AVW	DC4834VW
	230	60	2	4	440	944	DC4934AVW	DC4934VW
180	225	45	1.1	3	276	690	DC4836AVW	DC4836VW
	250	69	2	4	547	1 140	DC4936AVW	DC4936VW
190	240	50	1.5	4	327	782	DC4838AVW	DC4838VW
	260	69	2	4	555	1 200	DC4938AVW	DC4938VW
200	250	50	1.5	4	337	826	DC4840AVW	DC4840VW
	280	80	2.1	5	667	1 500	DC4940AVW	DC4940VW

[Note] 1) Effective movement of the bearing on the free side in an axial direction.

<i>P</i>	Lubrication hole (mm)		Mounting dimensions (mm)			Fixed side Mass (kg)
	<i>n</i> qty	<i>d</i> ₀	<i>d</i> _a min.	<i>D</i> _a max.	<i>r</i> _a max.	
11	4	2	55	67	0.6	0.30
12.5	4	2	66	79	1	0.46
15	4	2	76	94	1	0.78
15	4	2	86	104	1	0.88
17.5	4	2.5	97	118	1	1.35
20	4	2.5	107	133	1	1.95
20	4	2.5	117	143	1	2.15
22.5	4	3	127	158	1	2.95
25	4	3	138.5	171.5	1.5	3.95
25	4	3	148.5	181.5	1.5	4.20
20	4	3	157	183	1	2.90
30	6	4	160	200	2	6.65
20	4	3	167	193	1	3.05
30	6	4	170	210	2	7.00
22.5	4	3	177	208	1	4.10
30	6	4	180	220	2	7.35
22.5	4	4	187	218	1	4.30
34.5	6	4	190	240	2	10.7
25	4	4	198.5	231.5	1.5	5.65
34.5	6	5	200	250	2	11.2
25	4	4	208.5	241.5	1.5	5.90
40	6	6	212	268	2	15.7

Full complement type cylindrical roller bearings for crane sheaves

open type

d 220 ~ 440 mm

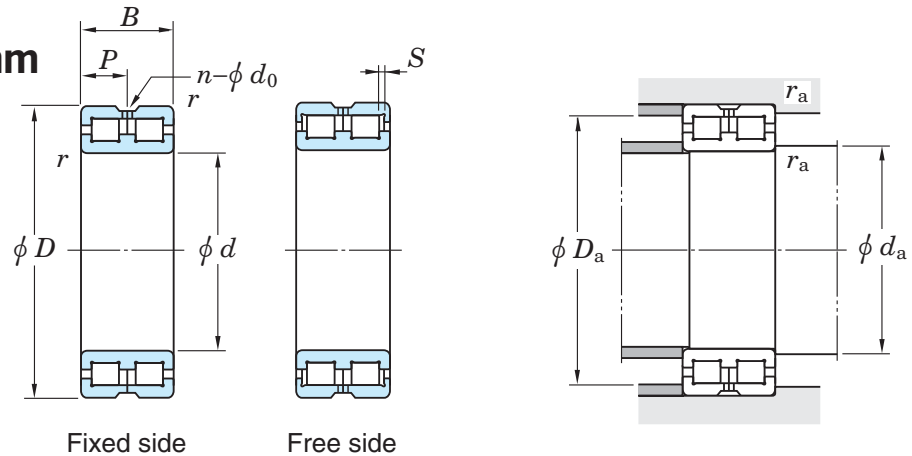

Boundary dimensions (mm)				S ¹⁾ (mm)	Basic load ratings (kN)		Bearing No.	
d	D	B	r min.		C_r	C_{0r}	Fixed side	Free side
220	270	50	1.5	4	355	971	DC4844AVW	DC4844VW
	300	80	2.1	5	707	1 600	DC4944AVW	DC4944VW
240	300	60	2	4	509	1 330	DC4848AVW	DC4848VW
	320	80	2.1	5	735	1 720	DC4948AVW	DC4948VW
260	320	60	2	4	532	1 450	DC4852AVW	DC4852VW
	360	100	2.1	6	1 070	2 520	DC4952AVW	DC4952VW
280	350	69	2	4	663	1 720	DC4856AVW	DC4856VW
	380	100	2.1	6	1 130	2 700	DC4956AVW	DC4956VW
300	380	80	2.1	6	802	2 160	DC4860AVW	DC4860VW
	420	118	3	6	1 560	3 710	DC4960AVW	DC4960VW
320	400	80	2.1	6	832	2 310	DC4864AVW	DC4864VW
	440	118	3	6	1 620	3 940	DC4964AVW	DC4964VW
340	420	80	2.1	6	853	2 430	DC4868AVW	DC4868VW
	460	118	3	6	1 660	4 150	DC4968AVW	DC4968VW
360	440	80	2.1	6	880	2 580	DC4872AVW	DC4872VW
	480	118	3	6	1 700	4 390	DC4972AVW	DC4972VW
380	480	100	2.1	6	1 310	3 570	DC4876AVW	DC4876VW
	520	140	4	7	2 290	5 600	DC4976AVW	DC4976VW
400	540	140	4	7	2 380	5 990	DC4980AVW	DC4980VW
420	560	140	4	7	2 440	6 270	DC4984AVW	DC4984VW
440	600	160	4	7	2 970	7 390	DC4988AVW	DC4988VW

[Note] 1) Effective movement of the bearing on the free side in an axial direction.

	Lubrication hole (mm)			Mounting dimensions (mm)			Mass Fixed side (kg)
	<i>P</i>	<i>n</i> qty	<i>d</i> ₀	<i>d</i> _a min.	<i>D</i> _a max.	<i>r</i> _a max.	
	25	6	4	228.5	261.5	1.5	6.40
	40	6	6	232	288	2	17.1
	30	6	5	250	290	2	10.2
	40	6	6	252	308	2	18.4
	30	6	5	270	310	2	11.0
	50	8	6	272	348	2	32.0
	34.5	6	5	290	340	2	16.0
	50	8	6	292	368	2	33.9
	40	8	6	312	368	2	23.0
	59	8	8	314	406	2.5	53.0
	40	8	6	332	388	2	24.3
	59	8	8	334	426	2.5	56.0
	40	8	6	352	408	2	25.6
	59	8	8	354	446	2.5	59.0
	40	8	6	372	428	2	27.0
	59	8	8	374	466	2.5	62.0
	50	8	6	392	468	2	45.3
	70	8	8	398	502	3	92.3
	70	8	8	418	522	3	96.4
	70	8	8	438	542	3	101
	80	8	8	458	582	3	139

KOYO

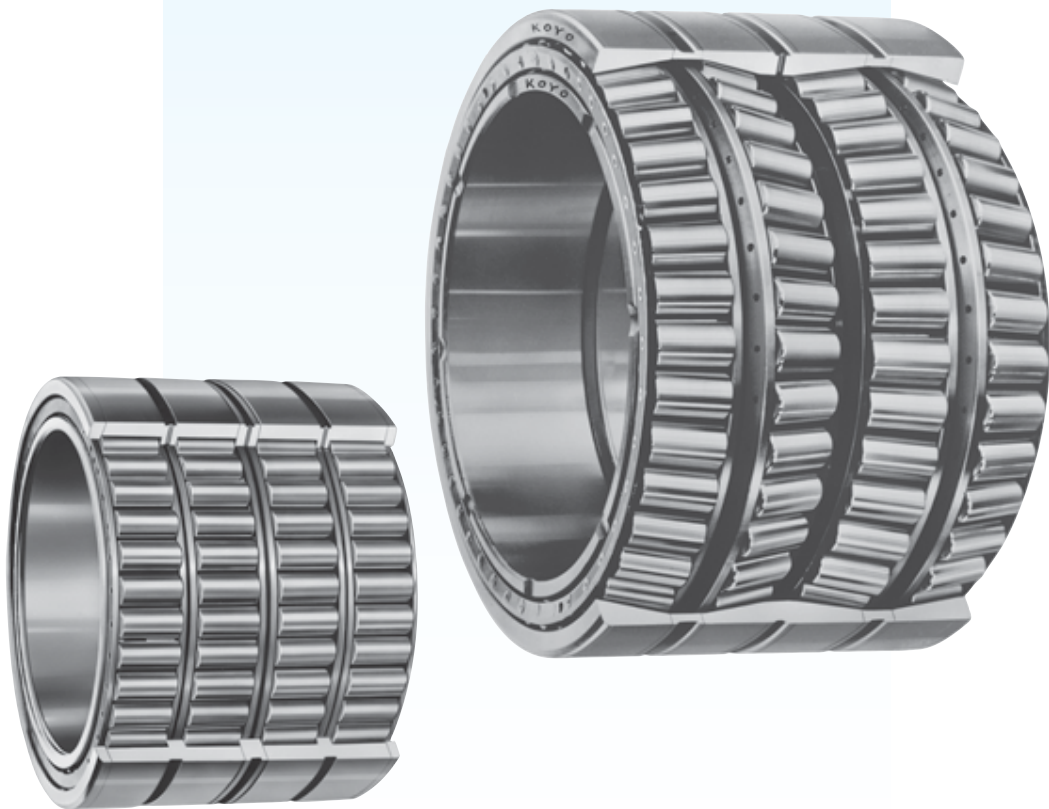

Rolling mill roll neck bearings

Rolling mill roll neck four-row cylindrical roller bearings and tapered roller bearings are designed to achieve the maximum load rating capacity in a limited space.

- Four-row cylindrical roller bearings
 - Suitable for high-speed rotation. Thin section designs are also available.
 - The inner ring raceway surface and the roll can be finished simultaneously after the inner ring is mounted on the roll neck. This feature is useful in improving rolling mill accuracy.

- Four-row tapered roller bearings
 - Suitable for low- and medium-speed rotation. Available in both metric and inch series.
 - The internal clearance is preadjusted, facilitating mounting.
 - More sealed type four-row tapered roller bearings are being used currently.

Four-row cylindrical roller bearings

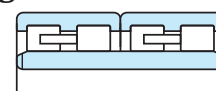

Cylindrical bore

Bore diameter **100 – 500** mm

Four-row tapered roller bearings

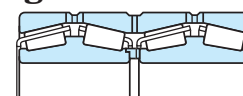

Open type

Bore diameter **65 – 500** mm

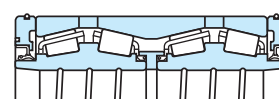

Sealed type

Bore diameter **75 – 800** mm

	Four-row cylindrical roller bearings	Four-row tapered roller bearings
Tolerances	As specified in JIS B 1514-1. (refer to Table 7-3 on pp. A 54-A 57.)	<ul style="list-style-type: none"> ● Metric series : as specified in BAS 1002. (refer to Table 7-6 on p. A 63.) ● Inch series : as specified in ABMA Section 19. (refer to Table 7-7 on pp. A 64, 65.) ● Special series (47T..., 4TR...) : Special allowances are applied to these series. For details, consult with JTEKT.
Recommended fits	Refer to Table 1.	<ul style="list-style-type: none"> ● Metric series : refer to Table 2. ● Inch series : refer to Table 3.
Internal clearance	Refer to Table 10-8 on pp. A 100, 101. (JTEKT should be consulted to determine the clearance according to application conditions.)	Refer to Table 10-10 on p. A 104.
Equivalent load	Dynamic equivalent radial load : $P_r = F_r$ Static equivalent radial load : $P_{0r} = F_r$	Dynamic equivalent radial load : $\left[\text{when } \frac{F_a}{F_r} \leq e \right] P_r = F_r + Y_2 F_a$ $\left[\text{when } \frac{F_a}{F_r} > e \right] P_r = 0.67 F_r + Y_3 F_a$ Static equivalent radial load : $P_{0r} = F_r + Y_0 F_a$

[Note] For axial load factor Y_2 , Y_3 and Y_0 , and the constant e , use values listed in the specification table.

Table 1 Roll neck four-row cylindrical roller bearing recommended fits

 Unit : μm

Inner ring and roll neck (shaft)						Outer ring and chock (housing)					
Nominal bore diameter d (mm)		Single plane mean bore diameter deviation Δ_{dmp}		Roll neck diameter deviation		Nominal outside diameter D (mm)		Single plane mean outside diameter deviation Δ_{Dmp}		Chock bore diameter deviation	
over	up to	upper	lower	upper	lower	over	up to	upper	lower	upper	lower
80	120	0	- 20	+ 59	+ 37	120	150	0	- 18	+ 40	0
120	180	0	- 25	+ 68	+ 43 (p6)	150	180	0	- 25	+ 40	0 (H7)
180	250	0	- 30	+ 79	+ 50	180	250	0	- 30	+ 46	0
250	280	0	- 35	+ 126	+ 94	250	315	0	- 35	+ 52	0 (H7)
280	315	0	- 35	+ 130	+ 98 (r6)	315	400	0	- 40	+ 75	+ 18 (G7)
315	355	0	- 40	+ 144	+ 108	400	500	0	- 45	+ 83	+ 20 (G7)
355	400	0	- 40	+ 150	+ 114	500	630	0	- 50	+ 92	+ 22 (G7)
400	450	0	- 45	+ 166	+ 126 (r6)	630	800	0	- 75	+ 160	+ 80 (F7)
450	500	0	- 45	+ 172	+ 132	800	1 000	0	- 100	+ 176	+ 86 (F7)
500	560	0	- 50	+ 194	+ 150 (r6)	1 000	1 250	0	- 125	+ 203	+ 98 (F7)
560	630	0	- 50	+ 354	+ 310 (s6)	1 250	1 400	0	- 160	+ 235	+ 110 (F7)
630	710	0	- 75	+ 390	+ 340 (s6)	1 400	1 600	0	- 160	+ 345	+ 220 (E7)
710	800	0	- 75	+ 430	+ 380						
800	900	0	- 100	+ 486	+ 430 (s6)						
900	1 000	0	- 100	+ 526	+ 470						
1 000	1 120	0	- 125	+ 588	+ 520 (s6)						
1 120	1 250	0	- 125	+ 646	+ 580 (s6)						

[Note] The table above shows general values. JTEKT determines recommended fit on a case by case basis according to bearing materials and operating conditions to prevent the inner ring from creeping. Consult with JTEKT when referring to this table.

Table 2 Roll neck metric series four-row tapered roller bearing recommended fits

 Unit : μm

Double inner ring and roll neck (shaft)						Outer ring and chock (housing)					
Nominal bore diameter d (mm)		Single plane mean bore diameter deviation Δ_{dmp}		Roll neck diameter deviation		Nominal outside diameter D (mm)		Single plane mean outside diameter deviation Δ_{Dmp}		Chock bore diameter deviation	
over	up to	upper	lower	upper	lower	over	up to	upper	lower	upper	lower
80	120	0	- 20	- 120	- 150	120	150	0	- 20	+ 57	+ 25
120	180	0	- 25	- 150	- 175	150	180	0	- 25	+ 100	+ 50
180	250	0	- 30	- 175	- 200	180	250	0	- 30	+ 120	+ 50
250	315	0	- 35	- 210	- 250	250	315	0	- 35	+ 115	+ 50
315	400	0	- 40	- 240	- 300	315	400	0	- 40	+ 110	+ 50
400	500	0	- 45	- 245	- 300	400	500	0	- 45	+ 105	+ 50
500	630	0	- 50	- 250	- 300	500	630	0	- 50	+ 100	+ 50
630	800	0	- 75	- 325	- 400	630	800	0	- 75	+ 150	+ 75
800	1 000	0	- 100	- 350	- 425	800	1 000	0	- 100	+ 150	+ 75
1 000	1 250	0	- 125	- 425	- 500	1 000	1 250	0	- 125	+ 175	+ 100
1 250	1 600	0	- 160	- 510	- 600	1 250	1 600	0	- 160	+ 215	+ 125
						1 600	2 000	0	- 200	+ 250	+ 150

Table 3 Roll neck inch series four-row tapered roller bearing recommended fits Unit : μm

Double inner ring and roll neck (shaft)						Outer ring and chock (housing)					
Nominal bore diameter d (mm)(1/25.4)		Single plane mean bore diameter deviation Δ_{dmp}		Roll neck diameter deviation		Nominal outside diameter D (mm)(1/25.4)		Single plane mean outside diameter deviation Δ_{Dmp}		Chock bore diameter deviation	
over	up to	upper	lower	upper	lower	over	up to	upper	lower	upper	lower
76.2 (3.0)	101.6 (4.0)	+ 25	0	- 75	- 100	-	304.8 (12.0)	+ 25	0	+ 75	+ 50
101.6 (4.0)	127.0 (5.0)	+ 25	0	- 100	- 125	304.8 (12.0)	609.6 (24.0)	+ 51	0	+ 150	+ 100
127.0 (5.0)	152.4 (6.0)	+ 25	0	- 125	- 150	609.6 (24.0)	914.4 (36.0)	+ 76	0	+ 225	+ 150
152.4 (6.0)	203.2 (8.0)	+ 25	0	- 150	- 175	914.4 (36.0)	1 219.2 (48.0)	+ 102	0	+ 300	+ 200
203.2 (8.0)	304.8 (12.0)	+ 25	0	- 175	- 200	1 219.2 (48.0)	1 524.0 (60.0)	+ 127	0	+ 375	+ 250
304.8 (12.0)	609.6 (24.0)	+ 51	0	- 200	- 250	1 524.0 (60.0)	-	+ 127	0	+ 450	+ 300
609.6 (24.0)	914.4 (36.0)	+ 76	0	- 250	- 325						
914.4 (36.0)	1 219.2 (48.0)	+ 102	0	- 300	- 400						
1 219.2 (48.0)	-	+ 127	0	- 375	- 475						

Four-row cylindrical roller bearings

d 100 ~ (160) mm

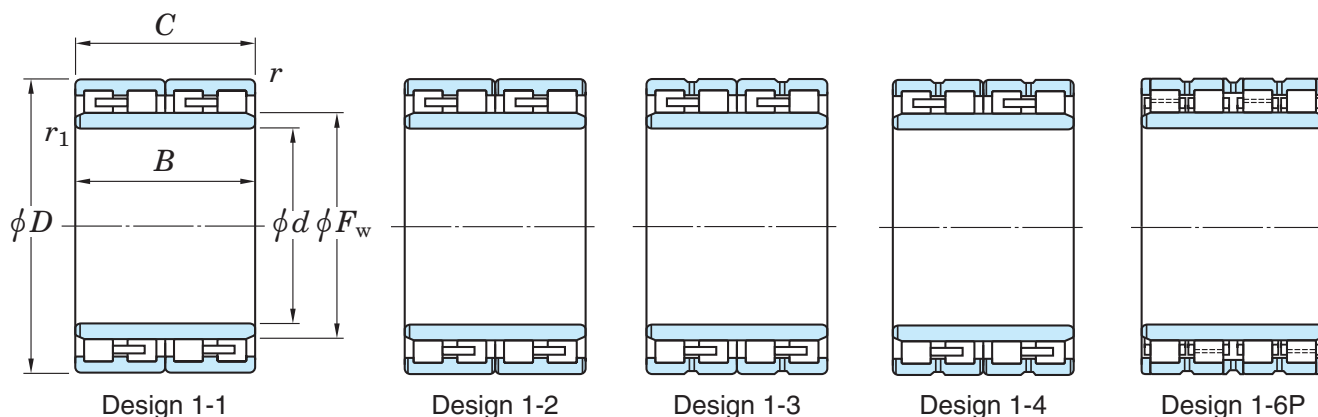

Boundary dimensions (mm)							Basic load ratings (kN)		Bearing No.
d	D	B	C	F_w	$r_{\min.}$	$r_{1\min.}$	C_r	C_{0r}	
100	140	120	120	110	1.1	1.1	485	945	20FC14120
110	170	90	90	127	2	2	428	692	22FC1790
	180	120	120	128	2	2	636	971	22FC18120
115	165	90	90	132.5	1.1	1.1	398	751	23FC1690
120	165	87	87	134.5	1.1	1.1	374	745	24FC1787
	180	105	105	135	2	1.1	487	796	4CR120
127	174.65	150.812	150.812	139.5	1.1	1.1	630	1 300	25FC17150
	203.2	127	127	147	2	2	740	1 180	25FC20127
130	200	104	104	150	2	2	566	953	26FC20104
	200	125	125	149	2	2	752	1 310	26FC20125
140	190	119	119	154	1.5	1.5	565	1 160	28FC19119W
	210	116	116	158	2	2	675	1 120	28FC21116
145	210	155	155	166	1.1	1.1	845	1 710	29FC21155
	225	156	156	169	2	2	912	1 680	313924
150	200	120	120	162	2	2	672	1 400	30FC20120
	210	120	120	168.5	2	2	686	1 380	30FC21120
	210	150	150	165	2	2	872	1 780	30FC21150
	220	150	150	170	2	2	887	1 760	30FC22150
	220	150	150	168	2	2	889	1 760	30FC22150A
	230	156	156	174	2	2	961	1 810	313891-1
160	220	180	180	177	2	2	964	2 170	32FC22180
	230	130	130	180	2.1	2.1	867	1 740	314190

[Notes] 1) Design numbers indicate the following meanings
 with P..... pin type cages
 without P..... machined cages

	Outer ring with rib	Outer ring with loose rib
One inner ring	1-1, 1-2, 1-3, 1-4	1-6P
Two inner rings	2-1P, 2-2, 2-2P, 2-3, 2-4	2-5P, 2-6P
Extended inner ring		3-1, 3-1P, 3-2P

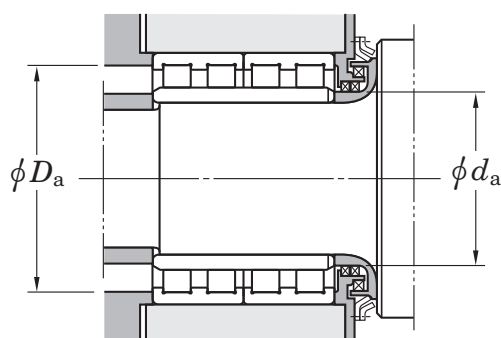
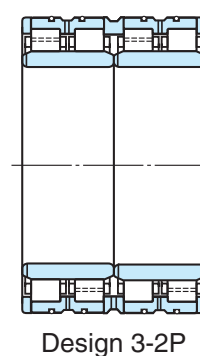
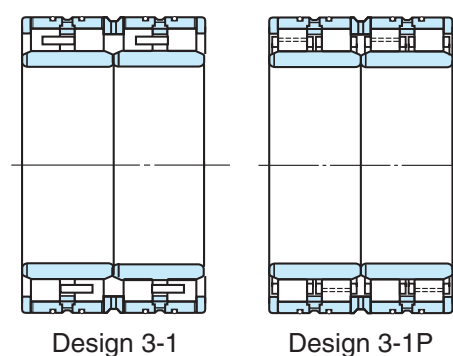
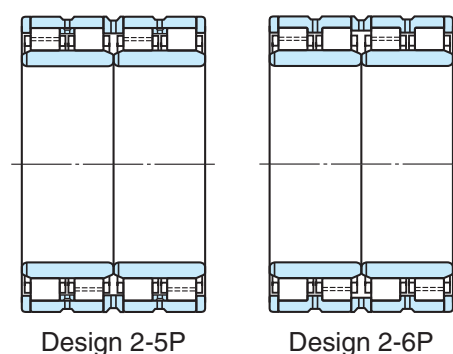
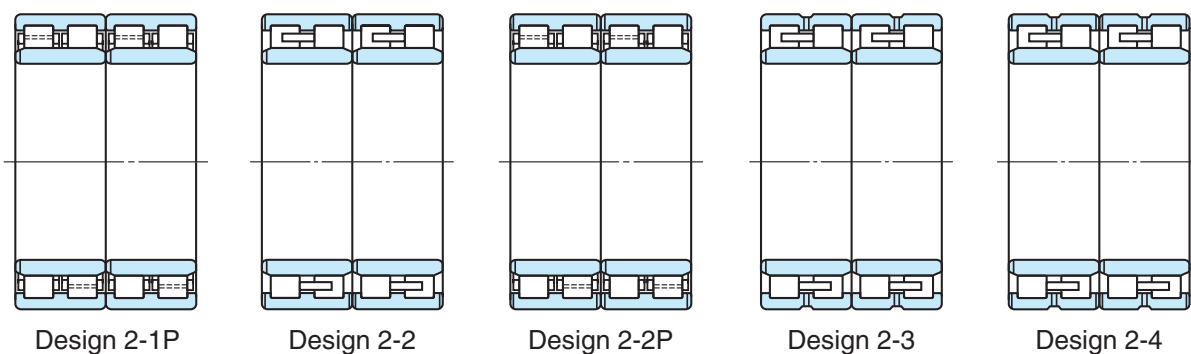

Design ¹⁾	Mounting dimensions (mm)						(Refer.) Mass (kg)
	d_a min.	d_a max.	D_a min.	r_a ²⁾ max.	r_b ²⁾ max.		
2-2	107	133	131	1	1	5.6	
1-2	120	160	155	2	2	7.4	
2-2	119	170	164	2	1.5	12	
1-1	122	158	154	1	1	6.5	
1-2	127	158	154	1	1	5.6	
1-2	127	170	165	2	1	9.3	
2-2	134	167	163	1	1	10.5	
1-3	137	193	185	2	2	15.4	
1-2	140	190	182	2	2	11.8	
1-2	140	190	183	2	2	14.4	
1-3	149	181	178	1.5	1.5	9.6	
1-2	150	200	194	2	2	13.5	
1-2	152	203	196	1	1	17.8	
1-2	155	215	205	2	2	22.9	
1-2	160	190	188	2	2	10.1	
2-2	160	200	196	2	2	12.8	
1-2	160	200	195	2	2	15.9	
1-2	160	210	202	2	2	19.2	
1-2	160	210	200	2	2	19.5	
1-2	160	220	210	2	2	23.8	
1-2	170	210	205	2	2	20.5	
1-2	172	218	212	2	2	17.7	

2) r_a indicates housing chamfer dimension corresponding to outer ring chamfer dimension r . r_b indicates the shaft chamfer dimension corresponding to inner ring chamfer dimension r_1 .

Four-row cylindrical roller bearings

d (160) ~ 190 mm

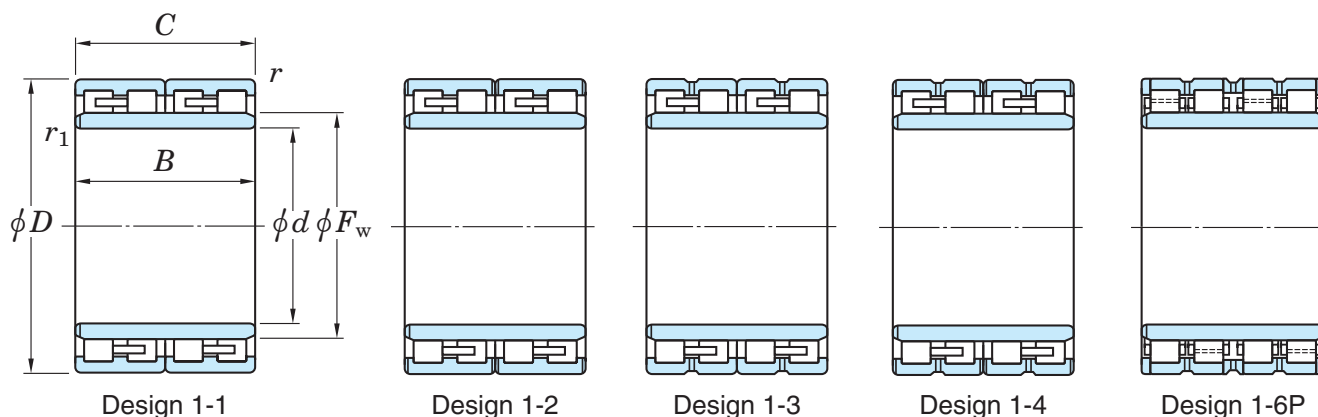

Boundary dimensions (mm)							Basic load ratings (kN)		Bearing No.
d	D	B	C	F_w	$r_{\min.}$	$r_{1\min.}$	C_r	C_{0r}	
160	230	168	168	182	1.1	1.1	1 040	2 210	32FC23170
	230	168	168	180	2	2	1 040	2 200	32FC23170A
	230	168	168	179	2	2	1 110	2 210	32FC23170B
	230	180	180	177	2	2	1 140	2 270	32FC23180A
	240	120	120	183	2.1	2.1	663	1 140	32FC24120W
	240	170	170	183	2.1	2.1	1 180	2 220	32FC24170
170	230	120	120	187	2	2	782	1 680	34FC23120
	240	156	156	190	2	2	972	2 050	34FC24156A
	240	156	156	189	2	2	1 060	2 100	34FC24156B
	240	190	190	187	1.5	1.5	1 260	2 620	34FC24190
	250	168	168	192	2.1	2.1	1 170	2 230	34FC25168
	250	170	170	192	2.1	2.1	1 170	2 230	34FC25170
	260	150	150	195	2.1	2.1	1 100	2 000	34FC26150
178	258.75	150	150	199	1.5	1.5	1 090	2 070	36FC26150
180	250	156	156	200	2	2	1 020	2 130	36FC25156A
	260	168	168	202	2.1	2.1	1 150	2 390	313812W
	260	168	168	202	2.1	2.1	1 230	2 420	36FC26168
	265	180	180	203	2	2	1 300	2 600	36FC27180
190	260	168	168	212	2.1	2.1	1 140	2 600	38FC26168-1
	270	170	170	212	2	2	1 140	2 310	38FC27170
	270	170	170	213	2	2	1 140	2 310	38FC27170A
	270	200	200	212	2	2	1 460	3 080	314199
	280	200	200	214	2.1	2.1	1 550	3 100	38FC28200
	290	190	190	215	2.1	2.1	1 550	2 860	38FC29190

[Notes] 1) Design numbers indicate the following meanings
 with P pin type cages
 without P machined cages

	Outer ring with rib	Outer ring with loose rib
One inner ring	1-1, 1-2, 1-3, 1-4	1-6P
Two inner rings	2-1P, 2-2, 2-2P, 2-3, 2-4	2-5P, 2-6P
Extended inner ring		3-1, 3-1P, 3-2P

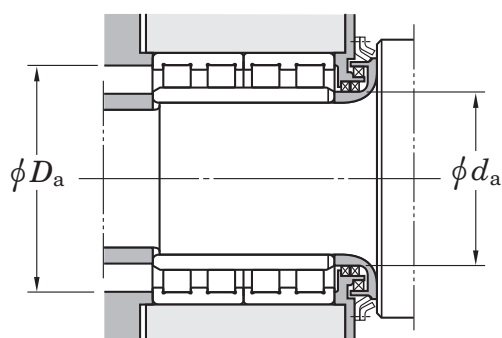
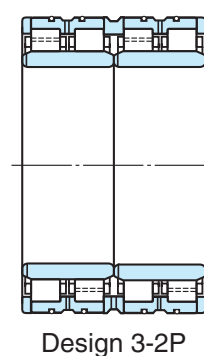
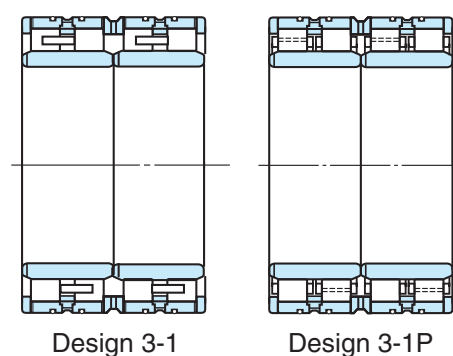
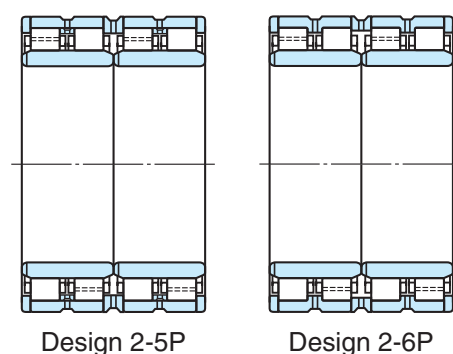
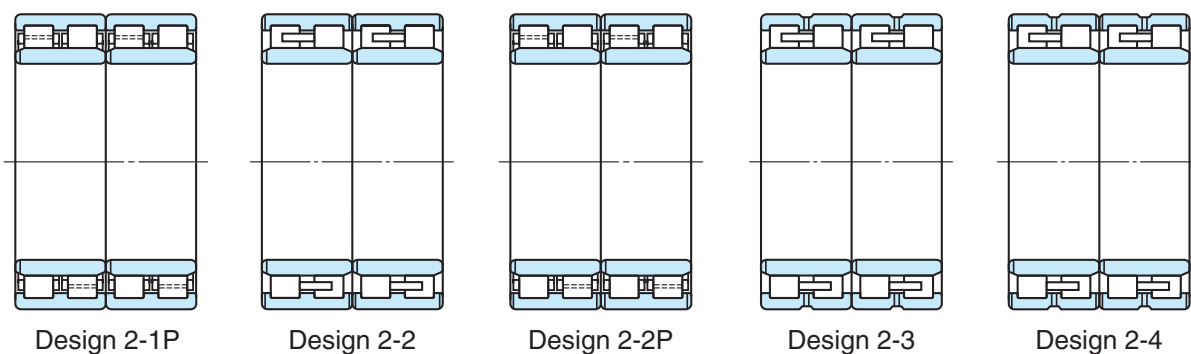

Design ¹⁾	Mounting dimensions (mm)						(Refer.) Mass (kg)
	d_a min.	d_a max.	D_a min.	r_a ²⁾ max.	r_b ²⁾ max.		
1-2	167	223	214	1	1	22.8	
1-2	170	220	212	2	2	23.1	
1-4	170	220	215	2	2	22.6	
1-2	170	220	213	2	2	24.1	
1-3	172	228	219	2	2	18.5	
1-2	172	228	223	2	2	26.8	
1-2	180	220	215	2	2	14.4	
1-2	180	230	222	2	2	22.4	
1-2	180	230	225	2	2	21.8	
1-2	179	231	223	1.5	1.5	26.9	
1-2	182	238	232	2	2	27.6	
1-2	182	238	232	2	2	27.8	
1-2	182	248	237	2	2	28.8	
1-2	187	250	239	1.5	1.5	25.8	
1-2	190	240	234	2	2	23.3	
1-4	192	248	238	2	2	29.7	
1-2	192	248	242	2	2	29.3	
1-2	190	255	243	2	2	33.6	
1-2	202	248	244	2	2	26.5	
1-2	200	260	250	2	2	30.8	
1-2	200	260	251	2	2	31.0	
1-2	200	260	252	2	2	36.1	
1-2	202	268	258	2	2	42	
1-2	202	278	265	2	2	44.9	

2) r_a indicates housing chamfer dimension corresponding to outer ring chamfer dimension r . r_b indicates the shaft chamfer dimension corresponding to inner ring chamfer dimension r_1 .

Four-row cylindrical roller bearings

d 195 ~ 230 mm

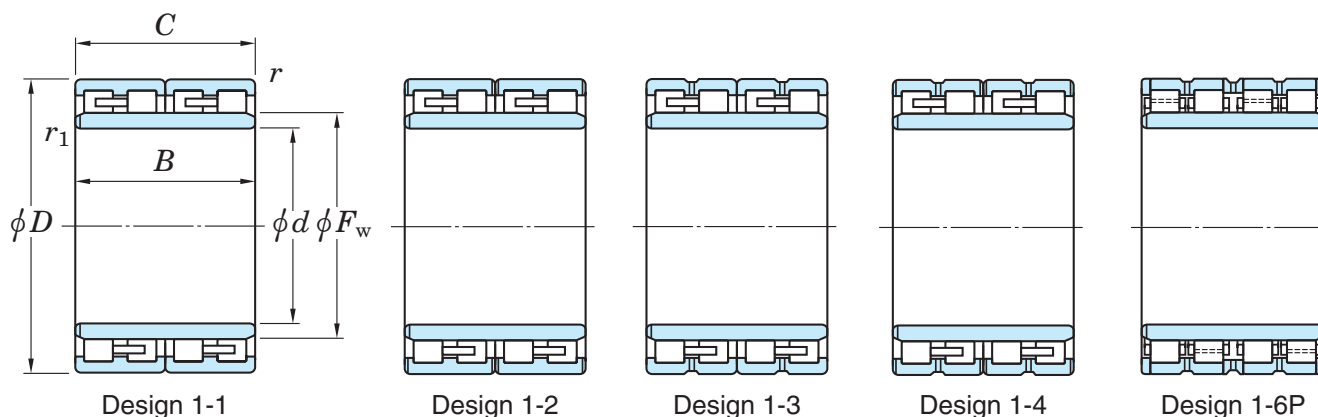

Boundary dimensions (mm)							Basic load ratings (kN)		Bearing No.
d	D	B	C	F_w	$r_{\min.}$	$r_{1\min.}$	C_r	C_{0r}	
195	300	226	226	220	2.1	2.1	1 960	3 690	39FC30226
200	270	170	170	222	2	2.1	1 190	2 780	314553
	280	152	152	222	2.1	2.1	1 100	2 150	40FC28152BW
	280	170	170	222	2.1	2.1	1 280	2 620	40FC28170
	280	188	188	222	2.1	2.1	1 350	2 810	40FC28188
	280	190	190	223	3	3	1 460	3 100	40FC28190A
	280	200	200	222	2	2	1 450	3 090	313893-1
	280	200	200	224	2.1	2.1	1 450	3 330	40FC28200
	290	192	192	226	2.1	2.1	1 460	3 030	313811
	310	160	160	232	2.1	2.1	1 260	2 240	40FC31160
	310	206	206	227	2.1	2.1	1 790	3 240	40FC31206
206	299.97	170	170	229	2	2	1 470	2 780	41FC30170
210	290	192	192	236	2.1	2.1	1 460	3 270	42FC29192
	300	210	210	234	2.1	2.1	1 660	3 490	42FC30210
220	300	150	150	240	2.1	2.1	1 210	2 500	44FC30150W
	310	192	192	247	2.1	2.1	1 520	3 270	313837-1
	310	192	192	246	2	2	1 630	3 420	313837A
	310	192	192	245	3	2.1	1 450	2 980	44FC31192W
	310	225	225	244	2.1	2.1	1 880	4 160	44FC31225A
	320	210	210	246	2.1	2.1	1 760	3 490	44FC32210
	320	210	210	248	2.1	2.1	1 810	3 740	44FC32210-1
	340	180	180	256	3	3	1 500	2 750	44FC34180A
230	330	206	206	260	2.1	2.1	1 880	3 980	313824A
	340	260	260	261	3	3	2 310	4 900	46FC34260

[Notes] 1) Design numbers indicate the following meanings
 with P pin type cages
 without P machined cages

	Outer ring with rib	Outer ring with loose rib
One inner ring	1-1, 1-2, 1-3, 1-4	1-6P
Two inner rings	2-1P, 2-2, 2-2P, 2-3, 2-4	2-5P, 2-6P
Extended inner ring		3-1, 3-1P, 3-2P

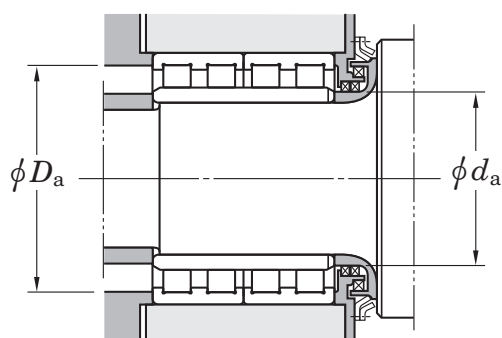
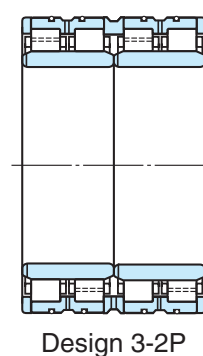
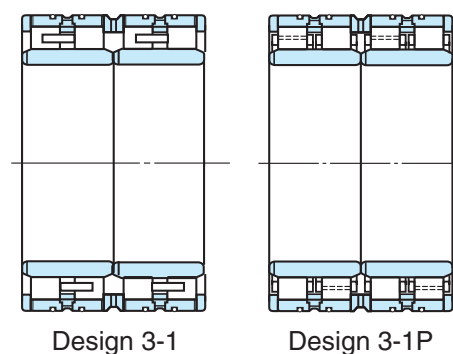
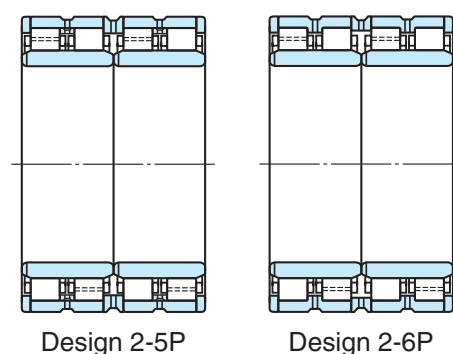
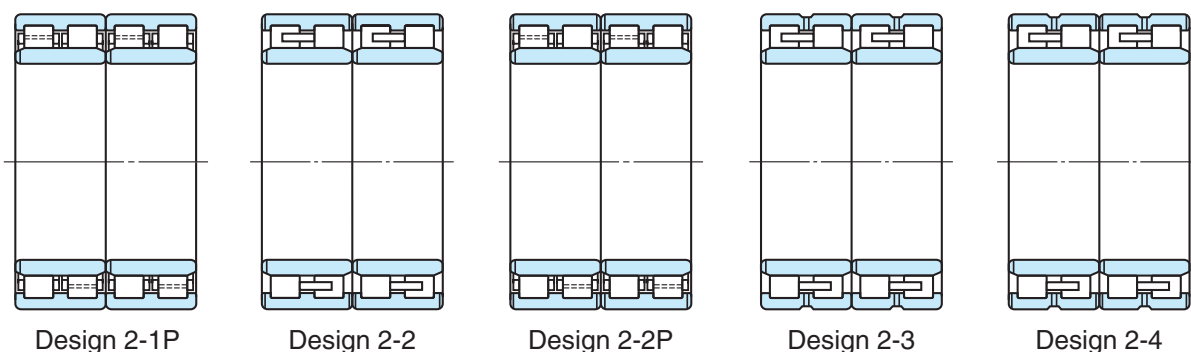

Design ¹⁾	Mounting dimensions (mm)						(Refer.) Mass (kg)
	d_a min.	d_a max.	D_a min.	r_a ²⁾ max.	r_b ²⁾ max.		
1-2	207	288	274	2	2	57.9	
1-2	212	260	254	2	2	28.0	
1-3	212	268	262	2	2	28.0	
1-2	212	268	262	2	2	31.7	
1-2	212	268	262	2	2	35.0	
1-2	214	266	263	2.5	2.5	36.0	
1-2	210	270	262	2	2	37.7	
1-2	212	268	260	2	2	38.7	
1-2	212	278	268	2	2	42.0	
1-1	212	298	282	2	2	44.6	
1-2	212	298	283	2	2	56.6	
1-2	216	289	277	2	2	39.2	
1-2	222	278	274	2	2	38.1	
1-2	222	288	278	2	2	47.3	
1-3	232	288	280	2	2	30.7	
1-2	232	298	289	2	2	45.5	
1-2	230	300	291	2	2	44.9	
1-3	232	296	289	2.5	2	43.9	
1-2	232	298	288	2	2	53.5	
1-2	232	308	296	2	2	55.4	
1-4	232	308	296	2	2	56.7	
1-4	234	326	310	2.5	2.5	59.0	
1-2	242	318	308	2	2	57.5	
1-2	244	326	313	2.5	2.5	81.2	

2) r_a indicates housing chamfer dimension corresponding to outer ring chamfer dimension r . r_b indicates the shaft chamfer dimension corresponding to inner ring chamfer dimension r_1 .

Four-row cylindrical roller bearings

d 237 ~ (280) mm

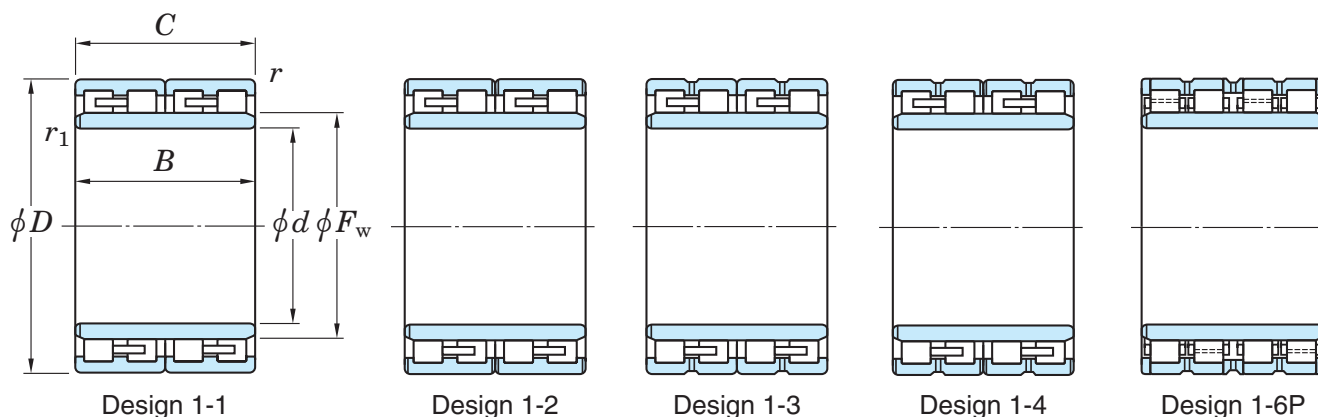

Boundary dimensions (mm)							Basic load ratings (kN)		Bearing No.
d	D	B	C	F_w	$r_{\min.}$	$r_{1\min.}$	C_r	C_{0r}	
237	339.67	200	200	264	2	2	1 840	3 780	47FC34200
240	330	220	220	270	3	3	1 780	4 250	312943/1YD
	330	220	220	264	2.1	2.1	1 830	4 120	48FC33220
	330	220	220	268	3	3	1 770	4 070	48FC33220BW
	330	250	250	263	2.1	2.1	2 160	4 910	48FC33250W
	340	200	200	266	3	3	1 880	3 780	48FC34200
	340	220	220	268	3	3	2 000	4 240	48FC34220
250	350	220	220	278	3	3	1 930	4 200	50FC35220
260	355	260	260	286	2.1	2.1	2 290	5 440	52FC35260
	360	192	192	287	2.1	2.1	1 750	3 740	52FC36192W
	360	200	200	287	2.1	2.1	1 880	4 110	52FC36200
	360	230	230	292.5	2.1	2.1	2 140	4 900	52FC36230CW
	360	230	230	292	2.1	2.1	2 020	4 790	52FC36230D
	360	260	260	287	2.1	2.1	2 300	5 320	52FC36260
	368	268	268	288	2.1	2.1	2 740	5 990	52FC37268W
	370	220	220	292	3	3	2 000	4 330	313823
	370	220	220	290	3	3	2 180	4 480	313823A
265	370	234	234	292	1.5	1.5	2 290	4 910	53FC37234A
	370	234	234	300	1.5	1.5	2 270	5 290	53FC37234B
270	380	230	230	298	2.1	2.1	2 330	4 910	54FC38230
280	380	170	170	306	2.1	2.1	1 710	3 590	56FC38170W
	390	220	220	312	3	3	2 070	4 640	313822
	390	220	220	308	3	3	2 180	4 670	313822A

[Notes] 1) Design numbers indicate the following meanings
 with P pin type cages
 without P machined cages

	Outer ring with rib	Outer ring with loose rib
One inner ring	1-1, 1-2, 1-3, 1-4	1-6P
Two inner rings	2-1P, 2-2, 2-2P, 2-3, 2-4	2-5P, 2-6P
Extended inner ring		3-1, 3-1P, 3-2P

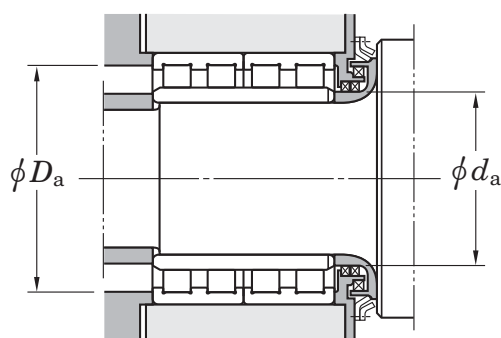
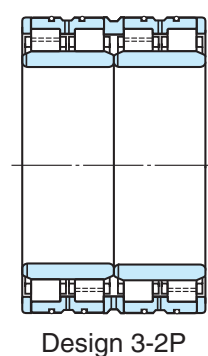
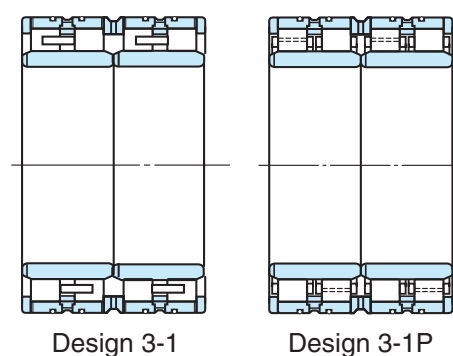
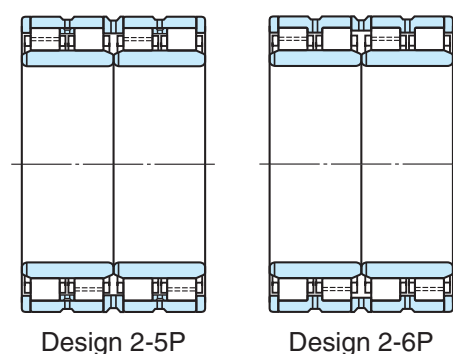
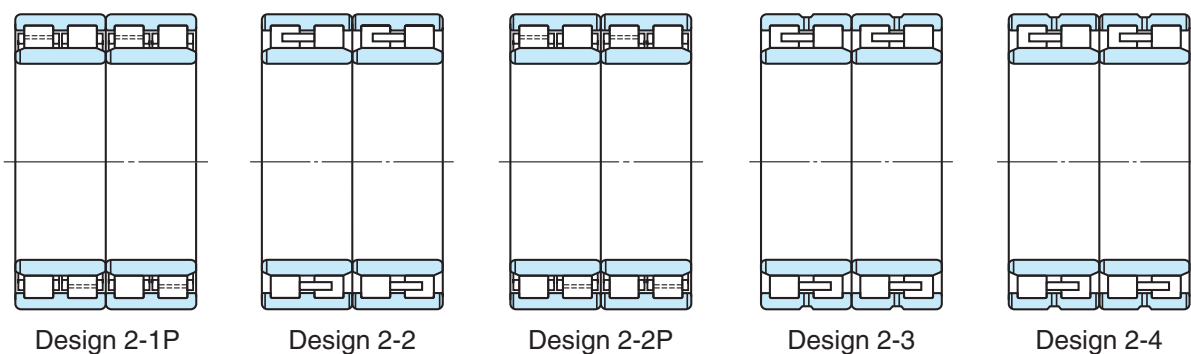

Design ¹⁾	Mounting dimensions (mm)					(Refer.) Mass (kg)
	d_a min.	d_a max.	D_a min.	r_a ²⁾ max.	r_b ²⁾ max.	
1-2	247	329	314	2	2	58.0
1-4	254	316	310	2.5	2.5	55.5
1-2	252	318	308	2	2	54.3
1-4	254	316	310	2.5	2.5	55.5
1-3	252	318	309	2	2	63.7
1-2	254	326	318	2.5	2.5	56.3
1-2	254	326	318	2.5	2.5	63.4
1-2	264	336	326	2.5	2.5	64.6
2-2	272	343	332	2	2	75.0
1-3	272	348	335	2	2	59.8
1-2	272	348	335	2	2	62.0
1-4	272	348	340	2	2	69.7
1-2	272	348	336	2	2	72.6
2-2	272	348	335	2	2	80.0
1-4	272	356	344	2	2	89.9
1-2	274	356	342	2.5	2.5	76.0
1-2	274	356	346	2.5	2.5	75.0
1-2	272	358	346	2	2	88.5
1-2	274	361	346	1.5	1.5	76.3
2-2	274	361	348	1.5	1.5	78.5
1-2	282	368	354	2	2	80.0
1-3	292	368	356	2	2	55.0
1-2	294	376	362	2.5	2.5	81.8
1-2	294	376	362	2.5	2.5	79.7

2) r_a indicates housing chamfer dimension corresponding to outer ring chamfer dimension r . r_b indicates the shaft chamfer dimension corresponding to inner ring chamfer dimension r_1 .

Four-row cylindrical roller bearings

d (280) ~ (320) mm

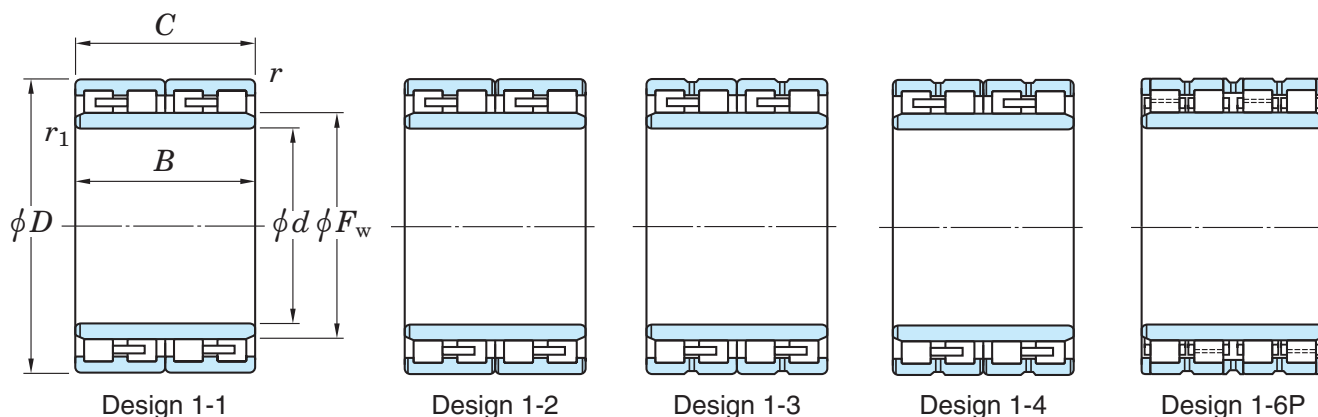

Boundary dimensions (mm)							Basic load ratings (kN)		Bearing No.
d	D	B	C	F_w	$r_{\min.}$	$r_{1\min.}$	C_r	C_{0r}	
280	390	220	220	306	3	2.1	2 520	5 350	313822C
	390	220	220	312	3	3	2 320	5 100	313822D
	390	240	240	312	3	3	2 460	5 620	56FC39240
	390	275	275	309	2.1	2.1	2 680	6 110	56FC39275B
	390	275	275	308	3	2.1	3 040	6 850	56FC39275J
	410	300	300	314	3	3	3 730	8 400	56FC41300
290	390	234	234	320	3	3	2 300	5 500	58FC39234
	400	180	180	320	3	3	1 880	4 010	58FC40180W
	410	240	240	320	3	3	2 610	5 540	58FC41240
	420	300	300	327	3	3	3 100	6 960	58FC42300
300	400	300	300	328	3	3	2 920	7 310	60FC40300A
	420	218	218	332	3	3	2 350	5 010	60FC42218
	420	240	240	332	3	3	2 660	5 750	60FC42240
	420	300	300	332	3	3	3 370	7 840	4CR300
	420	300	300	331	1.5	1.5	3 420	7 750	60FC42300DW
	420	300	300	332	2	2	3 750	8 690	60FC42300L-2
	420	300	300	332	3	3	3 250	7 270	60FC42300W
310	420	300	300	338	3	3	3 090	7 370	62FC42300
	430	240	240	344.5	3	3	2 640	5 770	62FC43240
	440	240	240	341	3	3	2 820	5 730	62FC44240
320	440	230	230	351	3	3	2 530	5 490	64FC44230/240
	450	240	240	358	3	3	2 700	5 740	4CR320
	450	240	240	355	3	3	2 700	5 730	64FC45240
	450	240	240	358	3	3	2 770	5 930	64FC45240CW
	460	340	340	360	3	3	3 860	8 730	64FC46340A

[Notes] 1) Design numbers indicate the following meanings
 with P pin type cages
 without P machined cages

	Outer ring with rib	Outer ring with loose rib
One inner ring	1-1, 1-2, 1-3, 1-4	1-6P
Two inner rings	2-1P, 2-2, 2-2P, 2-3, 2-4	2-5P, 2-6P
Extended inner ring		3-1, 3-1P, 3-2P

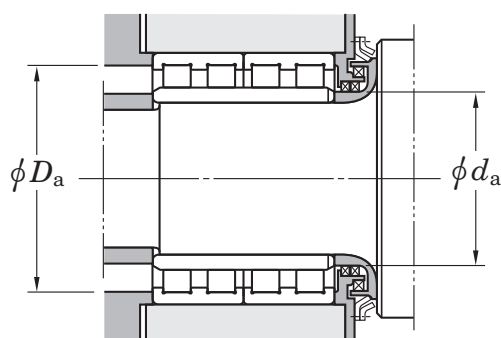
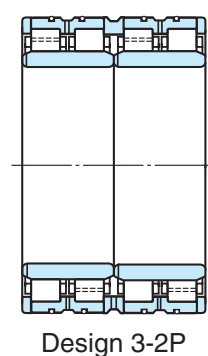
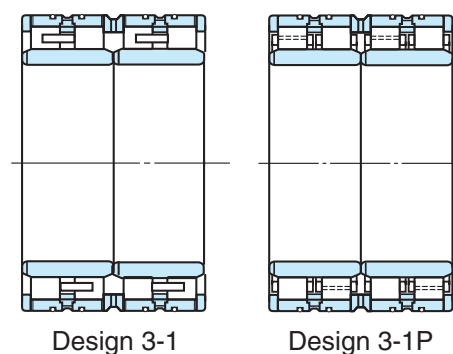
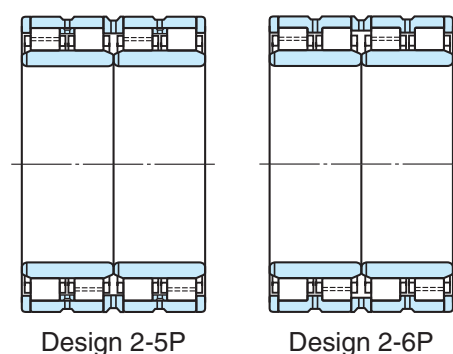
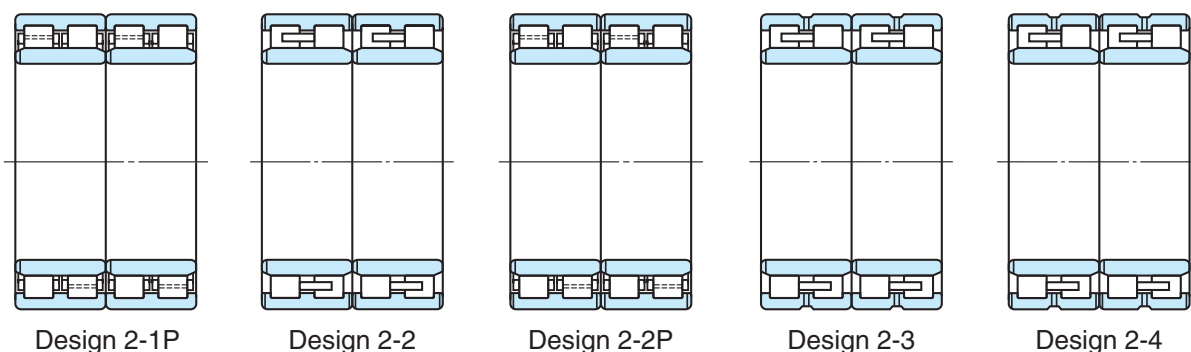

Design ¹⁾	Mounting dimensions (mm)						(Refer.) Mass (kg)
	d_a min.	d_a max.	D_a min.	r_a ²⁾ max.	r_b ²⁾ max.		
1-2	292	376	364	2.5	2	79.7	
1-2	294	376	366	2.5	2.5	80.1	
1-2	294	376	364	2.5	2.5	88.1	
1-2	292	378	363	2	2	100	
2-4	292	376	366	2.5	2	102	
2-6P	294	396	378	2.5	2.5	137	
1-2	304	376	368	2.5	2.5	80.0	
1-2	304	386	372	2.5	2.5	68.3	
1-2	304	396	380	2.5	2.5	99.0	
1-2	304	406	387	2.5	2.5	138	
1-2	314	386	378	2.5	2.5	103	
1-1	314	406	390	2.5	2.5	93.0	
1-1	314	406	392	2.5	2.5	102	
3-2P	314	406	392	2.5	2.5	125	
2-4	309	411	395	1.5	1.5	127	
2-6P	310	410	395	2	2	129	
2-3	314	406	394	2.5	2.5	127	
1-2	324	406	394	2.5	2.5	119	
1-2	324	416	404	2.5	2.5	105	
1-2	324	426	409	2.5	2.5	113	
1-2	334	426	411	2.5	2.5	103	
1-2	334	436	422	2.5	2.5	119	
1-2	334	436	419	2.5	2.5	117	
1-4	334	436	422	2.5	2.5	118	
1-4	334	446	428	2.5	2.5	187	

2) r_a indicates housing chamfer dimension corresponding to outer ring chamfer dimension r . r_b indicates the shaft chamfer dimension corresponding to inner ring chamfer dimension r_1 .

Four-row cylindrical roller bearings

d (320) ~ 370 mm

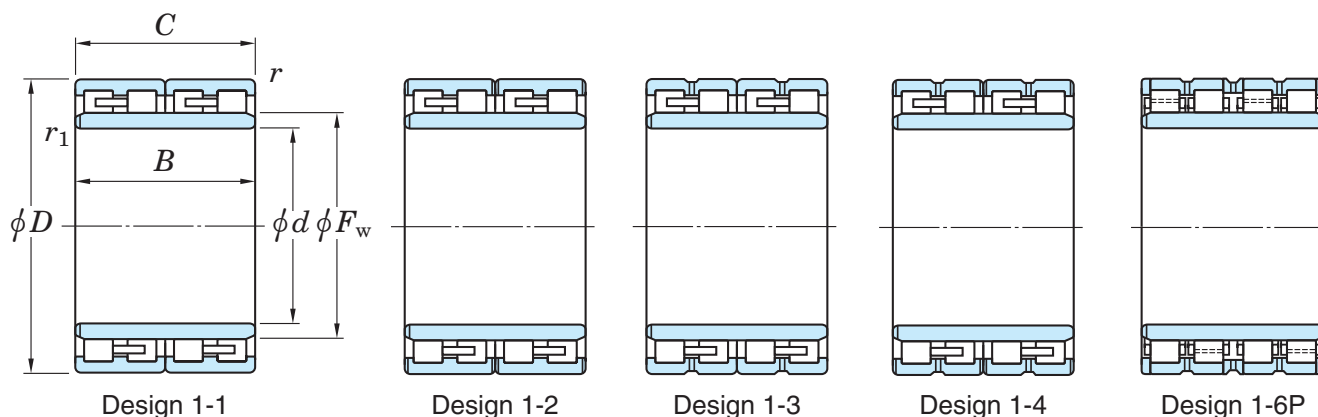

Boundary dimensions (mm)							Basic load ratings (kN)		Bearing No.
d	D	B	C	F_w	$r_{\min.}$	$r_1^{3)}$ min.	C_r	C_{0r}	
320	480	290	290	361	4	4	4 080	8 450	64FC48290
	480	350	350	364	2.1	2.1	5 010	11 000	314274A
330	440	200	200	358	3	3	2 340	5 220	66FC44200AW
	440	200	200	360	3	5	2 050	4 670	66FC44200W
	460	340	340	364	2.1	2.1	3 860	9 150	66FC46340
	460	340	340	368	4	4	4 060	9 800	66FC46340B
	460	380	380	364	2.1	2.1	4 380	10 800	66FC46380W
340	445	250	250	367	2.1	4	2 510	6 110	68FC45250W
	450	250	250	368	2.1	2.1	2 750	6 480	68FC45250BW
	480	350	350	378	4	SP	4 580	11 100	68FC48350-2
	480	350	350	378	3	SP	4 780	11 500	68FC48350D
	480	350	350	376	4	4	4 840	11 400	68FC48350L
	480	385	350	378	2.1	SP	4 780	11 500	68FC48350N
	490	300	300	380	5	5	3 500	7 690	68FC49300
	490	300	300	379	5	5	3 680	7 850	68FC49300A
343.052	457.098	254	254	374	3	3	2 640	6 190	69FC46254W
350	500	460	460	388	2	2	6 570	16 500	70FC50460
360	480	290	290	392	3	3	3 470	8 510	72FC48290
	500	250	250	394	3	3	3 510	7 340	72FC50250
	510	370	370	400	4	4	4 590	11 000	72FC51370
	520	380	380	405	2	5	5 800	13 700	72FC52380
370	520	380	380	409	5	5	5 320	13 200	74FC52380
	520	400	400	413	5	5	4 740	11 900	74FC52400W
	540	400	400	415	4	4	5 190	11 500	74FC54400A

[Notes] 1) Design numbers indicate the following meanings
 with P pin type cages
 without P machined cages

	Outer ring with rib	Outer ring with loose rib
One inner ring	1-1, 1-2, 1-3, 1-4	1-6P
Two inner rings	2-1P, 2-2, 2-2P, 2-3, 2-4	2-5P, 2-6P
Extended inner ring		3-1, 3-1P, 3-2P

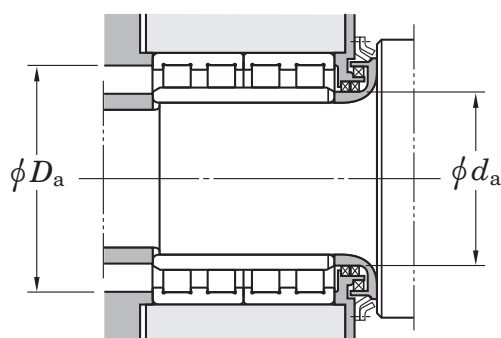
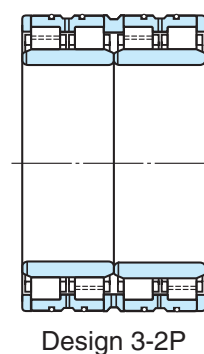
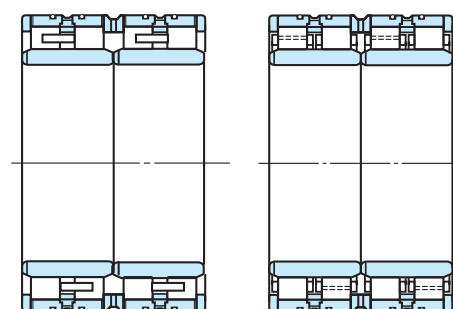
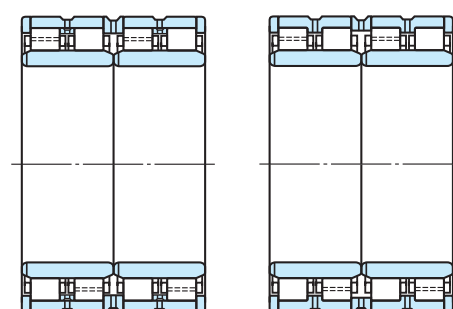
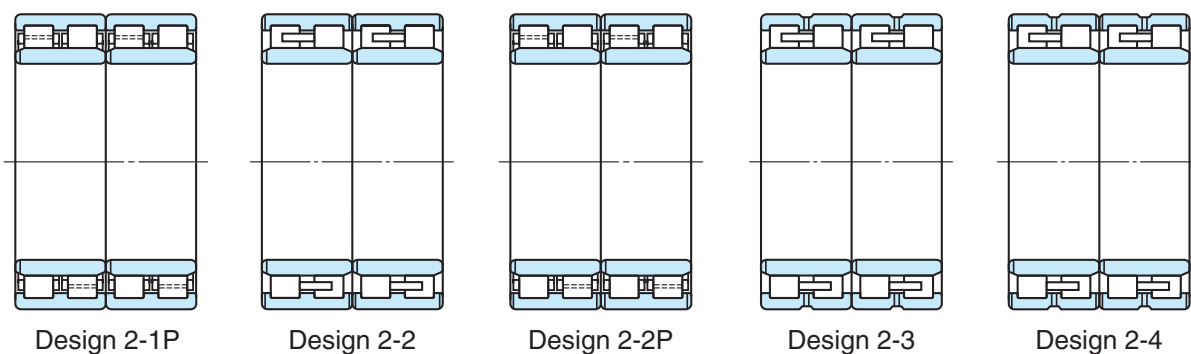

Design ¹⁾	Mounting dimensions (mm)						(Refer.) Mass (kg)
	d_a min.	d_a max.	D_a min.	r_a ²⁾ max.	r_b ²⁾ max.		
2-6P	338	462	441	3	3	189	
2-6P	332	468	444	2	2	227	
1-3	344	426	414	2.5	2.5	83.4	
1-3	352	426	412	2.5	4	83.0	
1-2	342	448	428	2	2	172	
1-2	348	442	432	3	3	176	
1-4	342	448	428	2	2	195	
1-3	358	433	419	2	3	100	
1-3	352	438	424	2	2	106	
2-4	354	462	446	3	2	211	
3-2P	354	466	448	2.5	2	201	
3-2P	358	462	448	3	3	201	
2-6P	358	468	448	2	3	209	
1-2	362	468	450	4	4	187	
1-2	362	468	453	4	4	182	
1-4	358	443	430	2.5	2.5	112	
2-6P	360	490	464	2	2	296	
1-2	374	466	452	2.5	2.5	145	
2-2	374	486	470	2.5	2.5	145	
1-2	378	492	470	3	3	241	
2-6P	382	510	485	2	4	270	
2-6P	392	498	481	4	4	257	
2-4	392	498	481	4	4	268	
1-2	388	522	499	3	3	311	

2) r_a indicates housing chamfer dimension corresponding to outer ring chamfer dimension r . r_b indicates the shaft chamfer dimension corresponding to inner ring chamfer dimension r_1 .
 3) SP indicates the specially chamfered form.

Four-row cylindrical roller bearings

d 375 ~ (420) mm

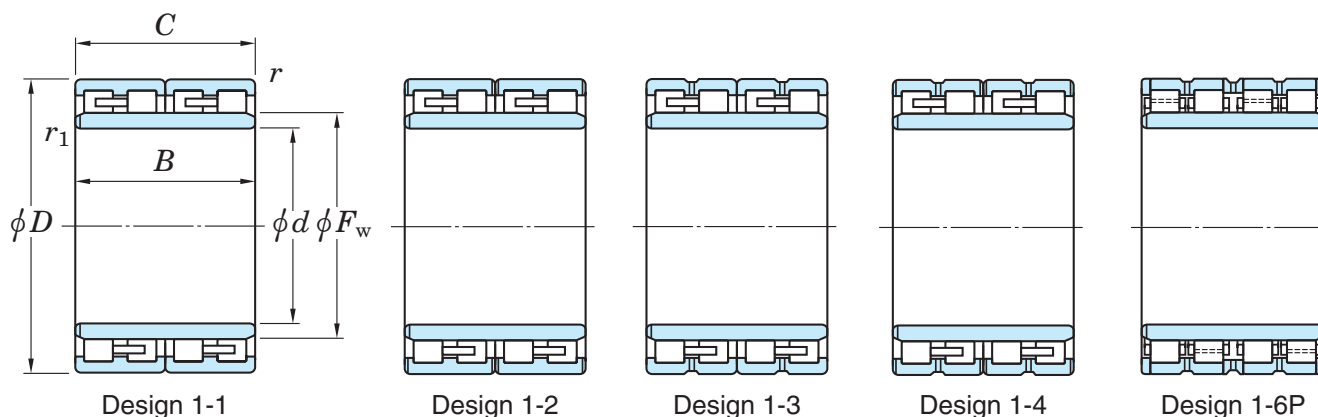

Boundary dimensions (mm)							Basic load ratings (kN)		Bearing No.
d	D	B	C	F_w	$r_{\min.}$	$r_1^{3)}$ min.	C_r	C_{0r}	
375	545	400	400	417	4	4	6 310	14 500	75FC55400
380	520	280	280	417	4	4	3 720	8 550	76FC52280
	520	290	290	418	4	4	3 760	8 840	76FC52290
	540	300	300	421	3	3	4 650	10 100	76FC54300
	540	340	340	422	4	4	4 600	10 300	76FC54340W
	540	360	360	422	4	4	5 480	12 900	76FC54360
	540	400	380	422	4	4	6 010	14 300	76FC54380
	540	400	400	422	4	4	6 040	14 600	76FC54400BW
540	400	400	422	4	4	6 040	14 600	76FC54400DW	
390	550	400	400	434	5	SP	5 130	12 400	78FC55400AW
400	520	250	250	432	4	4	2 920	7 100	80FC52250W
	560	360	360	441	5	5	5 570	13 400	80FC56360
	560	410	410	445	5	5	6 330	15 800	4CR400
	560	410	410	445	2	5	6 470	16 300	80FC56410
	600	380	380	450	5	5	6 610	14 300	80FC60380
406.4	609.6	304.8	304.8	460	5	5	4 380	8 750	81FC6130W
410	546	400	400	448	5	5	5 010	13 000	82FC55400
	600	440	440	460	5	5	8 070	18 800	82FC60440
418.5	600	410	410	470	5	5	6 630	15 700	84FC60410A
419	592	350	350	462	4	4	5 690	12 900	84FC59350
420	560	280	280	457	4	4	3 930	9 410	84FC56280
	560	400	400	458	4	4	4 870	12 700	84FC56400

[Notes] 1) Design numbers indicate the following meanings
 with P pin type cages
 without P machined cages

	Outer ring with rib	Outer ring with loose rib
One inner ring	1-1, 1-2, 1-3, 1-4	1-6P
Two inner rings	2-1P, 2-2, 2-2P, 2-3, 2-4	2-5P, 2-6P
Extended inner ring		3-1, 3-1P, 3-2P

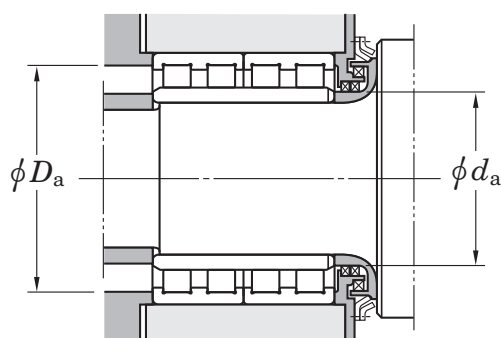
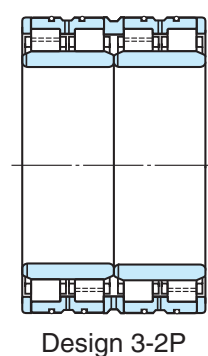
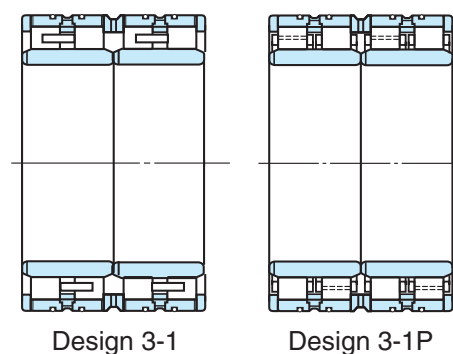
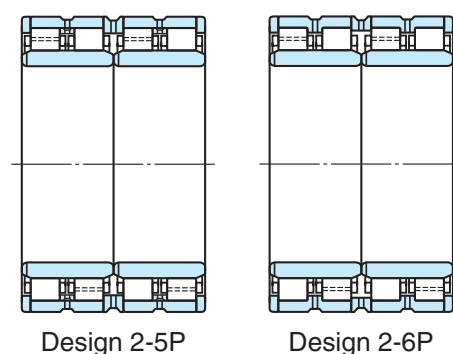
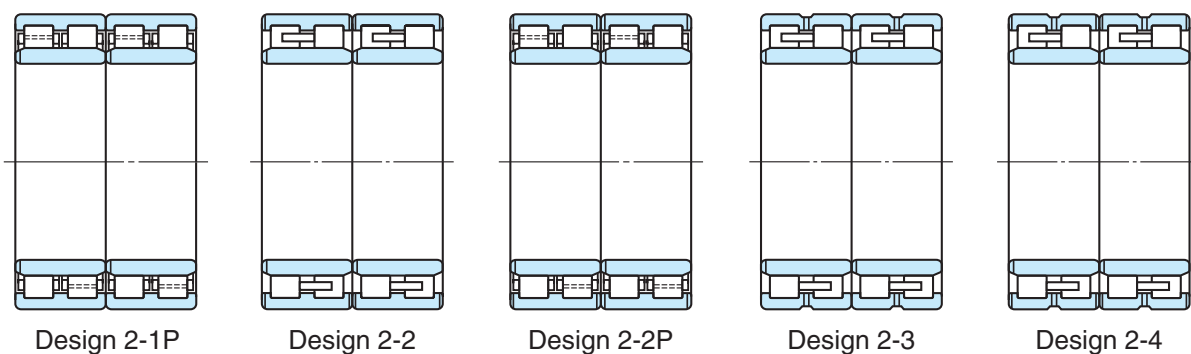

Design ¹⁾	Mounting dimensions (mm)						(Refer.) Mass (kg)
	d_a min.	d_a max.	D_a min.	r_a ²⁾ max.	r_b ²⁾ max.		
3-2P	393	527	505	3	3	315	
1-2	398	502	487	3	3	173	
1-2	398	502	486	3	3	181	
2-6P	394	526	505	2.5	2.5	222	
3-1	398	522	502	3	3	256	
2-6P	398	522	502	3	3	266	
2-6P	398	522	504	3	3	287	
2-6P	398	522	502	3	3	298	
3-2P	398	522	502	3	3	298	
2-3	410	528	510	4	4	296	
1-3	418	502	492	3	3	133	
2-6P	422	538	521	4	4	277	
3-2P	422	538	525	4	4	310	
2-6P	422	550	525	2	4	315	
2-6P	422	578	552	4	4	388	
1-4	429	587	556	4	4	307	
2-2	432	524	516	4	4	256	
2-6P	432	578	560	4	4	432	
2-6P	441	578	560	4	4	385	
1-6P	437	574	552	3	3	304	
1-1	438	542	527	3	3	189	
2-4	438	542	526	3	3	270	

2) r_a indicates housing chamfer dimension corresponding to outer ring chamfer dimension r . r_b indicates the shaft chamfer dimension corresponding to inner ring chamfer dimension r_1 .
 3) SP indicates the specially chamfered form.

Four-row cylindrical roller bearings

d (420) ~ (480) mm

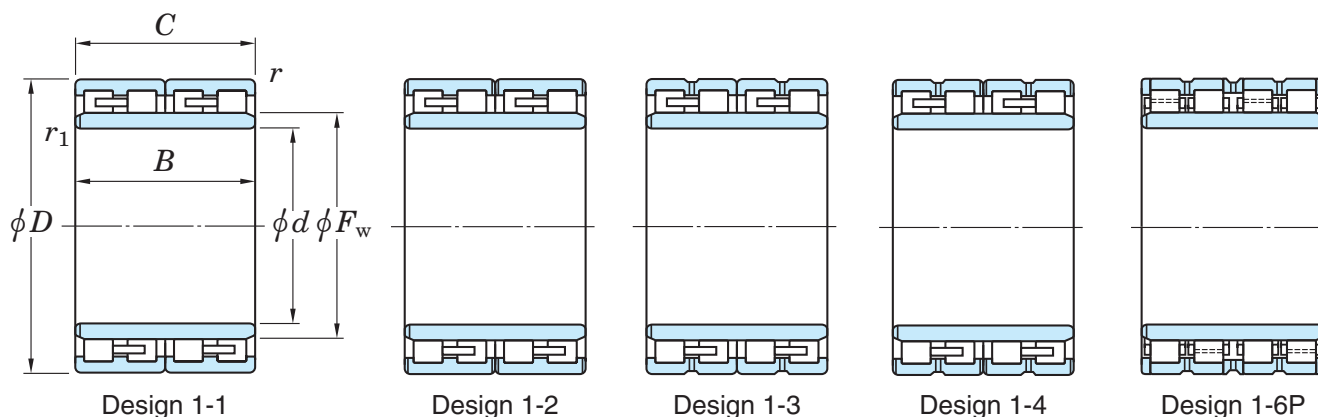

Boundary dimensions (mm)							Basic load ratings (kN)		Bearing No.
d	D	B	C	F_w	$r_{\min.}$	$r_1^{3)}$ min.	C_r	C_{0r}	
420	580	320	320	463	4	4	4 760	11 000	84FC58320 4CR420A
	600	440	440	470	5	5	7 240	17 700	
430	591	420	420	472	5	5	6 550	16 800	86FC59420 86FC59420-2 86FC59420A-1 86FC60450
	591	420	420	476	4	4	6 520	17 400	
	591	420	420	476	4	4	5 910	14 700	
	600	450	450	475	5	5	7 460	19 300	
440	590	270	270	482	4	4	3 620	8 460	88FC59270W 4CR440 88FC62450AW 88FC64420 88FC72452
	620	450	450	487	4	4	7 900	20 000	
	620	450	450	487	4	4	7 900	20 000	
	640	420	420	492	5	5	7 820	18 400	
	720	452	452	512	6	6	8 570	16 600	
444.5	660.4	323.85	323.85	500	4	4	6 040	12 600	89FC66324
445	635	375	375	496	4	4	6 240	14 600	4CR445
450	630	450	450	500	4	4	6 820	16 600	90FC63450A
460	600	400	400	497	4	SP	5 300	14 300	92FC60400 4CR460C 92FC62400BW 92FC62400D 92FC65470W 4CR460 92FC66500 4CR460D
	620	400	400	504	4	4	6 850	18 200	
	620	400	400	502	4	4	6 510	17 000	
	620	400	400	502	4	4	5 900	14 800	
	650	470	470	509	6	6	8 990	22 200	
	660	500	500	512	4	4	9 310	23 300	
	660	500	500	510	5	5	9 540	23 400	
	680	400	400	504	4	4	7 910	16 600	
480	650	450	450	525	5	5	8 480	22 400	96FC65450B

[Notes] 1) Design numbers indicate the following meanings
 with P pin type cages
 without P machined cages

	Outer ring with rib	Outer ring with loose rib
One inner ring	1-1, 1-2, 1-3, 1-4	1-6P
Two inner rings	2-1P, 2-2, 2-2P, 2-3, 2-4	2-5P, 2-6P
Extended inner ring		3-1, 3-1P, 3-2P

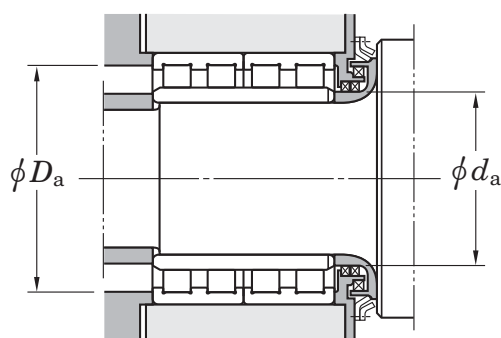
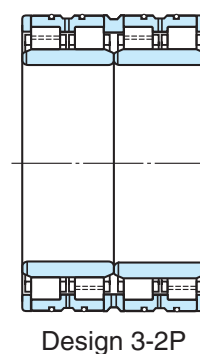
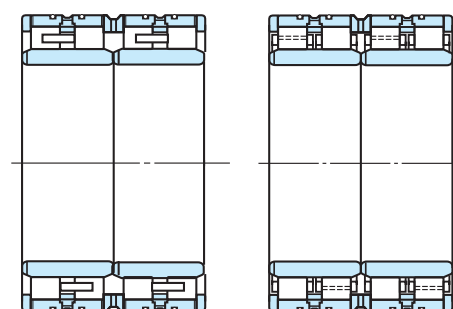
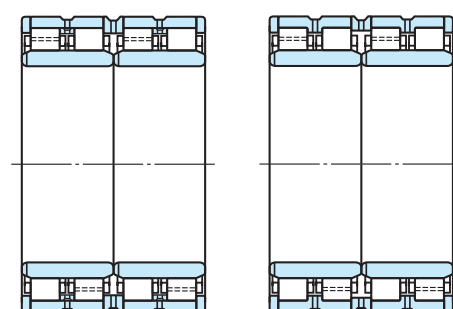
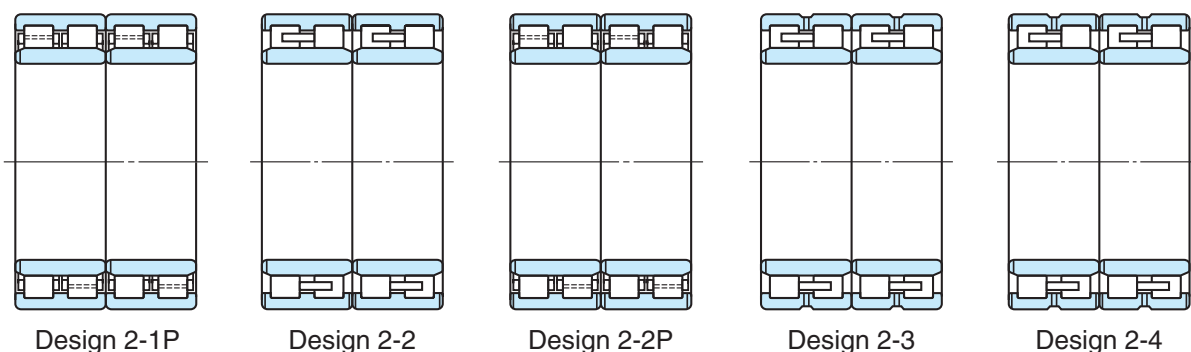

Design ¹⁾	Mounting dimensions (mm)						(Refer.) Mass (kg)
	d_a min.	d_a max.	D_a min.	r_a ²⁾ max.	r_b ²⁾ max.		
2-4	438	562	543	3	3	249	
3-1P	442	578	560	4	4	420	
2-2P	452	569	552	4	4	345	
2-6P	448	573	552	3	3	349	
1-3	448	573	552	3	3	340	
2-6P	452	578	559	4	4	405	
1-3	458	572	554	3	3	207	
3-1P	458	602	577	3	3	440	
2-6P	458	602	577	3	3	440	
2-6P	462	618	592	4	4	470	
1-6P	468	692	652	5	5	740	
1-6P	463	642	608	3	3	400	
3-1P	463	617	588	3	3	385	
2-2	468	612	590	3	3	433	
2-4	478	582	567	3	3	287	
3-1P	478	602	584	3	3	350	
1-6P	478	602	582	3	3	350	
1-4	478	602	583	3	3	340	
1-6P	488	622	609	5	5	494	
3-1P	478	642	612	3	3	590	
2-6P	482	638	614	4	4	573	
3-1P	478	662	624	3	3	510	
2-6P	502	628	615	4	4	440	

2) r_a indicates housing chamfer dimension corresponding to outer ring chamfer dimension r . r_b indicates the shaft chamfer dimension corresponding to inner ring chamfer dimension r_1 .
 3) SP indicates the specially chamfered form.

Four-row cylindrical roller bearings

d (480) ~500 mm

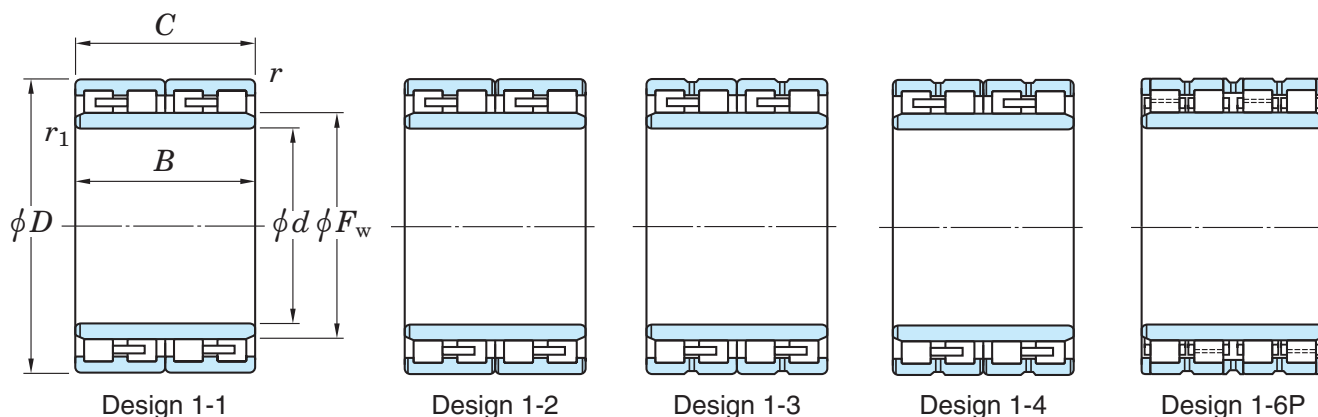

d	Boundary dimensions (mm)						Basic load ratings (kN)		Bearing No.
	D	B	C	F_w	$r^{3)}$ min.	$r_1^{3)}$ min.	C_r	C_{0r}	
480	650	460	460	526	5	5	7 730	20 800	96FC65460
	680	460	460	532	5	5	8 620	21 300	96FC68460
	680	500	500	534	5	5	8 620	22 000	4CR480
	680	500	500	534	5	5	8 620	22 000	4CR480B
	680	500	500	532	5	5	9 550	24 300	96FC68500A
495	615	360	360	530	SP	SP	4 030	12 000	99FC62360
500	670	450	450	540	5	SP	8 460	22 500	100FC67450A-3
	680	420	405	550	5	5	6 710	17 600	100FC68405
	680	450	450	542.5	4	4	8 980	23 100	100FC68450
	690	510	510	550	5	5	9 350	24 600	100FC69510A
	710	480	480	558	6	6	9 770	24 800	100FC71480
	720	400	400	558	5	6	8 320	18 900	100FC72400
	720	530	530	560	6	6	10 800	26 500	100FC72530
	720	530	530	568	5	4	11 000	28 900	100FC72530C
720	530	530	560	6	6	10 800	26 500	100FC72530W	

[Notes] 1) Design numbers indicate the following meanings
 with P pin type cages
 without P machined cages

	Outer ring with rib	Outer ring with loose rib
One inner ring	1-1, 1-2, 1-3, 1-4	1-6P
Two inner rings	2-1P, 2-2, 2-2P, 2-3, 2-4	2-5P, 2-6P
Extended inner ring		3-1, 3-1P, 3-2P

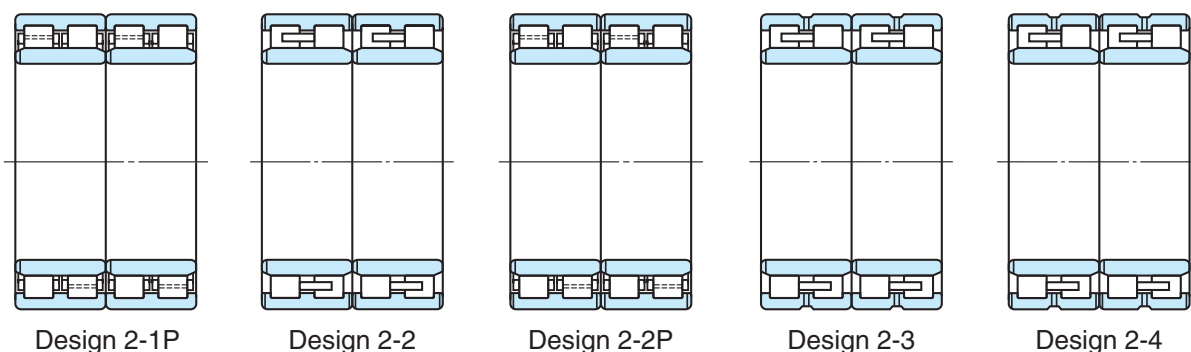

Design ¹⁾	Mounting dimensions (mm)						(Refer.) Mass (kg)
	d_a min.	d_a max.	D_a min.	r_a ²⁾ max.	r_b ²⁾ max.		
2-6P	502	628	610	4	4	443	
2-6P	502	658	632	4	4	545	
3-1P	502	658	630	4	4	580	
3-2P	502	658	630	4	4	580	
2-6P	502	658	632	4	4	595	
2-4	511	597	586	3	3	235	
2-6P	522	648	630	4	4	451	
2-6P	522	658	634	4	4	442	
2-6P	518	662	639	3	3	495	
3-2P	522	668	646	4	4	562	
2-6P	528	682	662	5	5	631	
1-6P	528	698	672	4	5	549	
2-6P	528	692	674	5	5	725	
2-6P	518	698	672	4	3	742	
3-2P	528	692	674	5	5	725	

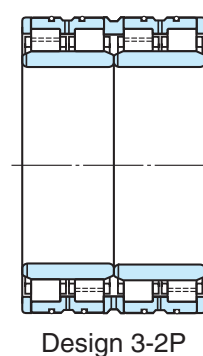
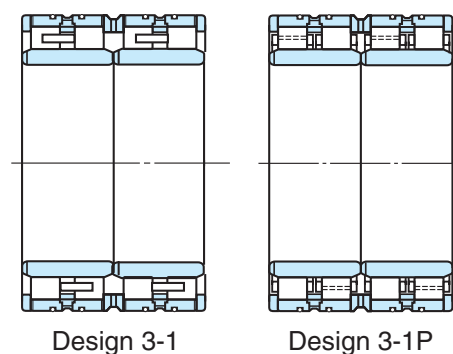
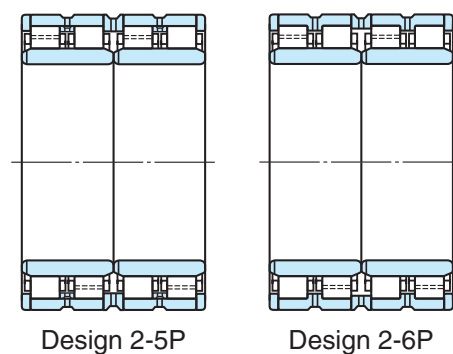

- 2) r_a indicates housing chamfer dimension corresponding to outer ring chamfer dimension r . r_b indicates the shaft chamfer dimension corresponding to inner ring chamfer dimension r_1 .
 3) SP indicates the specially chamfered form.

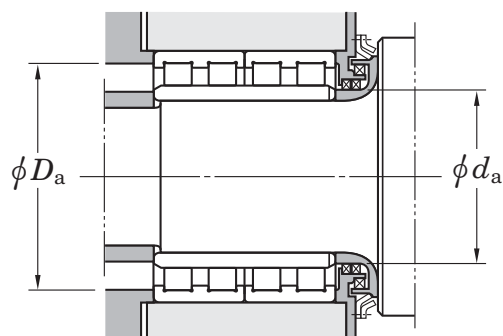

Four-row tapered roller bearings

d 65 ~ 133.350 mm

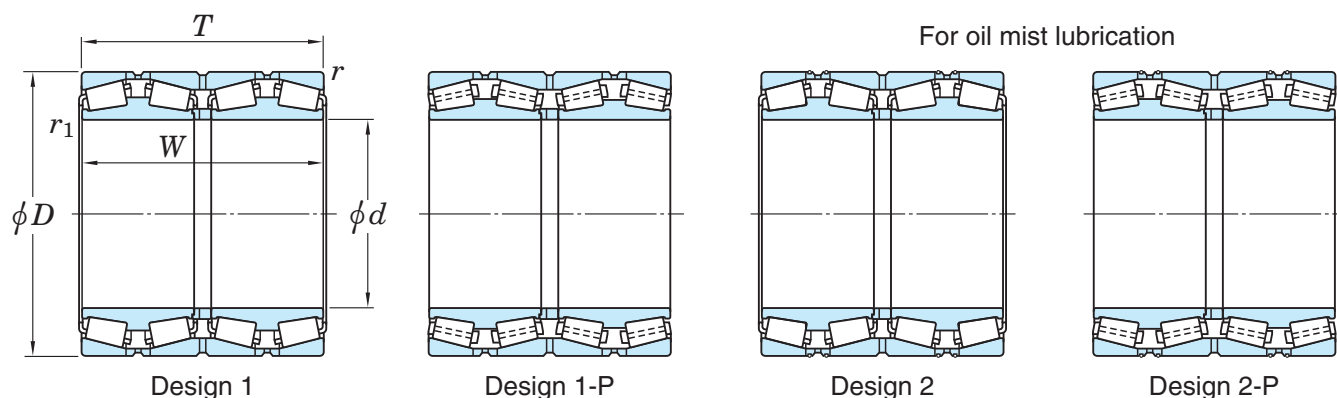

d	Boundary dimensions (mm)					Basic load ratings (kN)		Bearing No. ¹⁾
	D	T	W	r min.	r_1 min.	C_r	C_{Or}	
65	100	98	98	1.5	0.3	309	550	47T131010
80	115	88	88	1.5	1.5	265	543	47T1611
95	130	100	100	1.5	1.5	347	729	47T191310
100	140	104	104	2	2.5	338	661	37220
	140	104	104	2	1	407	852	37220A
	170	155	155	2	2.5	787	1 470	47T2017
105	160	150	150	1.5	1	747	1 420	47T211615
110	155	114	114	2	2.5	475	955	37222
	160	115	115	1.5	1	548	1 030	47T221612
	180	154	154	2	2.5	882	1 530	47T221815
	180	170	170	1	1	989	1 770	47T221817
115	155	115	115	1.5	0.6	437	1 020	47T231612A
	160	120	120	1.5	0.6	560	1 160	47T231612
120	170	124	124	2	2.5	472	943	37224
	170	130	130	1.5	2	591	1 290	47T241713
	200	132	132	2	2.5	706	1 200	47324
	210	174	174	2.5	3	1 110	1 770	47T242117
120.650	161.925	106.365	106.365	1.6	1.6	322	771	L624549D/514/514D
	166.688	152.414	152.400	3.3	1.6	637	1 460	LM124449D/410/410D
	174.625	139.703	141.288	1.6	0.8	712	1 450	M224749D/710/710D
127.000	182.563	158.750	158.750	3.2	1.6	778	1 720	48290D/20/20D
130	184	134	134	2	2.5	645	1 330	37226
133.350	196.850	193.675	193.675	3.2	1.6	1 070	2 240	67390D/22/22D

[Notes] 1) While metric series bearings have minus tolerances for bore and OD, inch series have plus tolerances. Refer to page C 82 for details of applicable tolerance standards.

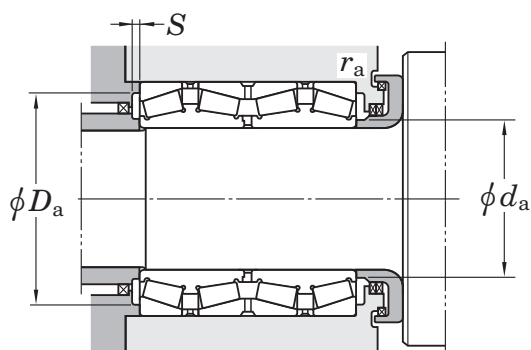

Design	Mounting dimensions (mm)							Constant e	Axial load factors			(Refer.) Mass (kg)
	d_a max.	D_a max.	D_a min.	S min.	r_a max.	r_b ²⁾ max.	Y_2		Y_3	Y_0		
1	73	91.5	87	3.6	1.5	0.3	0.46	1.47	2.19	1.44	2.82	
1	91	106.5	102	3.4	1.5	1.5	0.33	2.03	3.02	1.98	2.99	
1	104	121.5	117	3.5	1.5	1.5	0.33	2.03	3.02	1.98	3.83	
1	112	130	125	3.8	2	2	0.28	2.37	3.53	2.32	4.6	
1	110	130	125	4.1	2	1	0.40	1.68	2.50	1.64	4.8	
1	119	160	149	5.7	2	2	0.35	1.95	2.90	1.91	14.7	
1	118	151.5	146	5.9	1.5	1	0.33	2.03	3.02	1.98	10.6	
1	121	145	140	4.8	2	2	0.33	2.03	3.02	1.98	6.45	
1	121	151.5	146	5.2	1.5	1	0.43	1.57	2.34	1.53	7.63	
1	127	170	162	5.9	2	2	0.39	1.74	2.59	1.70	15.4	
1	126	174.5	162	6.5	1	1	0.33	2.03	3.02	1.98	17	
1	126	146.5	142	3.4	1.5	0.6	0.40	1.68	2.50	1.64	6.12	
1	124	151.5	147	5.7	1.5	0.6	0.35	1.95	2.90	1.91	7.2	
1	135	160	155	4.1	2	2	0.28	2.37	3.53	2.32	8.56	
1	133	161.5	155	4.4	1.5	2	0.40	1.68	2.50	1.64	9.38	
1	143	190	178	5.7	2	2	0.35	1.95	2.90	1.91	16.5	
1	143	198	188	4	2	2.5	0.33	2.03	3.02	1.98	24.5	
1	130	153	147	5.1	1.6	1.6	0.43	1.56	2.32	1.52	6.24	
1	132	155	150	2.3	3.3	1.6	0.29	2.30	3.42	2.25	9.84	
1	133	166	159	4.9	1.6	0.8	0.33	2.03	3.02	1.98	11.1	
1	140	171	166	3.7	3.2	1.6	0.31	2.21	3.29	2.16	13.6	
1	143	174	169	4.3	2	2	0.33	2.03	3.02	1.98	11	
1	148	185	180	5.6	3.2	1.6	0.34	1.96	2.92	1.92	19.8	

2) r_b indicates the shaft chamfer dimension corresponding to cone chamfer dimension r_1 .

Four-row tapered roller bearings

d 135 ~ 170 mm

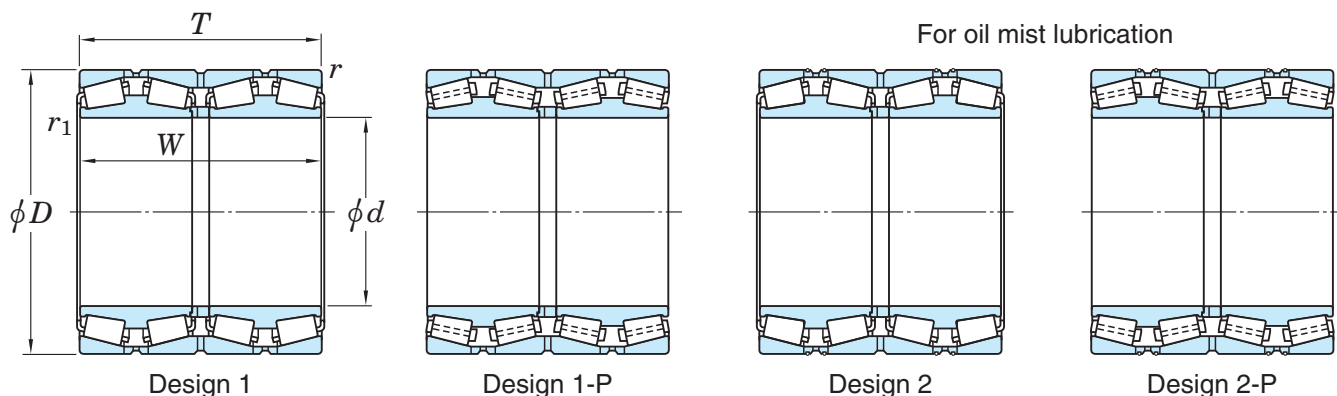

Boundary dimensions (mm)						Basic load ratings (kN)		Bearing No. ¹⁾
d	D	T	W	r min.	r_1 min.	C_r	C_{Or}	
135	180	160	160	1.5	1	559	1 290	47T271816
	195	160	160	1.5	0.6	938	1 930	47T272016
136.525	190.500	161.925	161.925	3.2	1.6	809	1 890	47T271916
	190.500	161.925	161.925	3.2	1.6	809	1 890	48393D/20/20D
139.700	200.025	160.340	157.166	3.3	0.8	844	1 960	48680D/20/20D
140	198	144	144	2	2.5	770	1 650	37228
	210	114	114	2	2.5	623	1 130	47228
	225	145	145	2.5	3	973	1 610	47328
145	195	130	130	1.5	0.6	641	1 550	47T292013
150	210	190	190	2	0.6	993	2 270	47T302119
	212	155	155	2.5	3	774	1 640	37230
152.400	222.250	174.625	174.625	1.6	1.6	1 080	2 390	M231649D/610/610D
160	226	165	165	2.5	3	873	1 870	37232
	250	145	145	2.5	3	1 090	1 870	47T322515
	265	173	173	2.5	1	1 320	2 400	47T322717
165.100	225.425	168.275	165.100	3.2	0.8	868	2 140	46791D/20/21D
168.275	247.650	192.088	192.088	3.2	1.6	1 190	2 800	67782D/20/21D
170	230	175	175	2	1	1 030	2 370	47T342318
	240	175	175	2.5	3	1 020	2 310	37234A
	240	175	175	2.5	1.5	1 120	2 340	47T342418A
	260	160	160	2.5	3	1 110	1 900	47T342616
	280	181	181	2.5	3	1 330	2 420	47334/181
	280	185	185	2.5	3	1 330	2 420	47334

[Notes] 1) While metric series bearings have minus tolerances for bore and OD, inch series have plus tolerances. Refer to page C 82 for details of applicable tolerance standards.

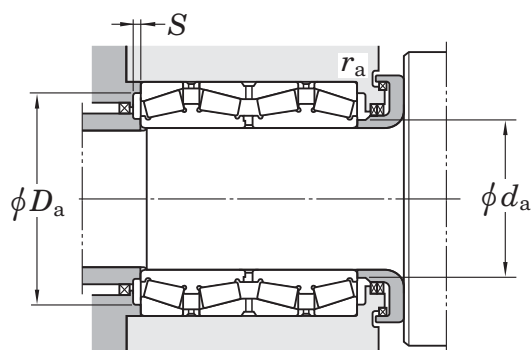

Design	Mounting dimensions (mm)							Constant e	Axial load factors			(Refer.) Mass (kg)
	d_a max.	D_a max.	D_a min.	S min.	r_a max.	r_b ²⁾ max.	Y_2		Y_3	Y_0		
1	146	171.5	166	1.4	1.5	1	0.33	2.03	3.02	1.98	10.7	
1	147	186.5	179	3.9	1.5	0.6	0.33	2.03	3.02	1.98	15.4	
2	150	179	174	4.8	3.2	1.6	0.32	2.10	3.13	2.06	14.3	
1	150	179	174	4.8	3.2	1.6	0.32	2.10	3.13	2.06	14.3	
1	157	187	182	4	3.3	0.8	0.34	2.01	2.99	1.96	16.6	
1	157	188	183	5.3	2	2	0.28	2.43	3.61	2.37	13.6	
1	160	200	190	6	2	2	0.27	2.47	3.67	2.41	13.7	
1	161	213	203	6.5	2	2.5	0.40	1.68	2.50	1.64	21.2	
1	158	186.5	177	5.1	1.5	0.6	0.40	1.68	2.50	1.64	11.1	
1	163	200	190	5	2	0.6	0.39	1.74	2.59	1.70	20.2	
1	168	200	190	6	2	2.5	0.28	2.37	3.53	2.32	16.7	
1	168	213	201	6	1.6	1.6	0.33	2.03	3.02	1.98	22.8	
1	178	214	204	6	2	2.5	0.28	2.37	3.53	2.32	20.1	
1	182	238	226	6.5	2	2.5	0.33	2.03	3.02	1.98	25.4	
1	193	253	241	7	2	1	0.35	1.95	2.90	1.91	37.6	
1	180	213	203	4.5	3.2	0.8	0.38	1.77	2.63	1.73	19.7	
1	189	236	226	5	3.2	1.6	0.44	1.54	2.29	1.50	31.7	
1	183	220	210	6	2	1	0.40	1.68	2.50	1.64	19.9	
1	189	228	218	5	2	2.5	0.33	2.03	3.02	1.98	24.2	
2	184	228	218	7.5	2	1.5	0.40	1.68	2.50	1.64	24.7	
1	194	248	238	6	2	2.5	0.35	1.95	2.90	1.91	28.5	
1	202	268	250	6	2	2.5	0.33	2.03	3.02	1.98	44	
1	202	268	250	6	2	2.5	0.33	2.03	3.02	1.98	44.8	

2) r_b indicates the shaft chamfer dimension corresponding to cone chamfer dimension r_1 .

Four-row tapered roller bearings

d 177.800 ~ 205 mm

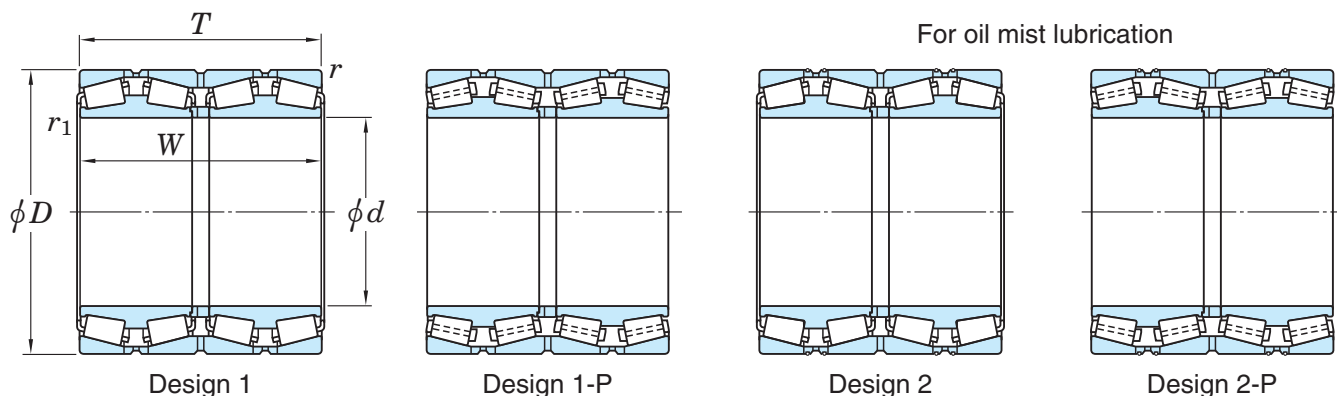

Boundary dimensions (mm)						Basic load ratings (kN)		Bearing No. ¹⁾
d	D	T	W	$r_{\min.}$	$r_{1\min.}$	C_r	C_{Or}	
177.800	247.650	192.088	192.088	3.2	1.6	1 190	2 800	67791D/20/21D 82681D/20/20D EE91700D/112/113XD
	279.400	234.948	234.950	3.2	1.6	1 660	3 290	
	285.750	222.245	222.500	3.2	1.6	1 520	2 860	
180	250	185	185	2.5	3	1 140	2 550	47T362519 37236 47T362616 47T362620 47T362818A 47336 47T363028
	254	185	185	2.5	3	1 140	2 550	
	260	160	160	2.5	1	1 090	2 090	
	260	200	200	2	2.5	1 390	2 950	
	280	181	181	2.5	3	1 510	2 830	
	300	202	202	3	4	1 580	2 750	
	300	280	280	3	4	2 400	4 430	
187	270	210	210	2.5	1	1 660	3 570	47T372721B
187.325	269.875	211.138	211.138	3.2	1.6	1 410	3 220	M238849D/810/810D
190	268	196	196	2.5	3	1 210	2 760	37238 47T382716
	270	160	160	2.5	1	1 170	2 370	
190.000	270.000	190.000	190.000	3.2	1.6	1 160	2 810	4TR3827
190.500	266.700	188.913	187.325	3.2	1.6	1 160	2 810	67885D/67820/67820D
198.438	284.163	225.425	225.425	3.2	1.6	1 740	3 780	M240648D/611/611D
200	280	206	206	2.5	1.5	1 670	3 830	47T402821 37240 47T403423
	282	206	206	2.5	3	1 490	3 380	
	340	234	234	3	4	2 340	4 150	
203.200	317.500	209.550	215.900	3.2	3.2	1 510	2 900	EE132082D/125/126D 93800D/125/127D
	317.500	266.700	266.700	3.2	1.6	2 070	4 540	
205	320	205	205	3	4	1 740	3 030	47T413221

[Notes] 1) While metric series bearings have minus tolerances for bore and OD, inch series have plus tolerances. Refer to page C 82 for details of applicable tolerance standards.

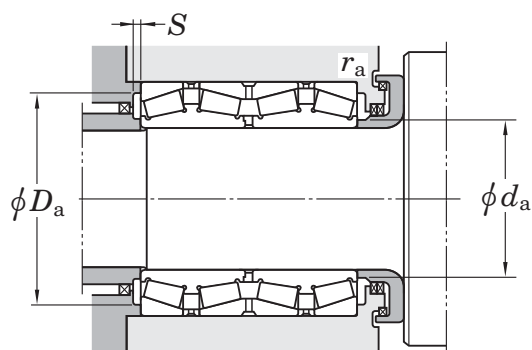

Design	Mounting dimensions (mm)							Constant <i>e</i>	Axial load factors			(Refer.) Mass (kg)
	<i>d_a</i> max.	<i>D_a</i> max.	<i>D_a</i> min.	<i>S</i> min.	<i>r_a</i> max.	<i>r_b</i> ²⁾ max.	<i>Y₂</i>		<i>Y₃</i>	<i>Y₀</i>		
1	189	235	225	5	3.2	1.6	0.44	1.54	2.29	1.50	28.4	
1	197	267	251	6.5	3.2	1.6	0.52	1.29	1.92	1.26	52.5	
1	201	273	251	3.5	3.2	1.6	0.43	1.57	2.34	1.53	53.7	
1	198	238	228	6	2	2.5	0.33	2.03	3.02	1.98	26.9	
1	198	242	232	6	2	2.5	0.33	2.03	3.02	1.98	29.1	
1	198	248	238	5	2	1	0.37	1.80	2.69	1.76	26.4	
1	200	250	240	4.5	2	2	0.31	2.15	3.20	2.10	33.6	
1	204	268	253	8	2	2.5	0.33	2.03	3.02	1.98	40.8	
1	211	286	267	5.5	2.5	3	0.35	1.95	2.90	1.91	54.9	
1	211	286	270	6	2.5	3	0.33	2.03	3.02	1.98	78.4	
1	205	258	248	8	2	1	0.33	2.03	3.02	1.98	39.1	
1	206	257	245	5	3.2	1.6	0.33	2.03	3.02	1.98	39.5	
1	210	256	246	6	2	2.5	0.33	2.03	3.02	1.98	33.4	
1	208	258	248	7	2	1	0.40	1.68	2.50	1.64	28.3	
1	208	257	244	6	3.2	1.6	0.48	1.42	2.11	1.38	34.7	
1	208.5	255.3	245.1	6	3.2	1.6	0.48	1.42	2.11	1.38	32.4	
1	215	271	260	5	3.2	1.6	0.33	2.03	3.02	1.98	44.7	
1	216	268	258	6.5	2	1.5	0.39	1.71	2.54	1.67	39.7	
1	223	270	260	5.5	2	2.5	0.28	2.43	3.61	2.37	39.6	
1	234	326	302	6	2.5	4	0.40	1.68	2.50	1.64	86	
1	235	304	284	7	3.2	3.2	0.31	2.15	3.21	2.11	61	
1	223	304	278	6.5	3.2	1.6	0.52	1.29	1.92	1.26	78.8	
1	230	306	292	7.5	2.5	3	0.46	1.46	2.17	1.42	58.9	

2) *r_b* indicates the shaft chamfer dimension corresponding to cone chamfer dimension *r₁*.

Four-row tapered roller bearings

d 206.375 ~ 235 mm

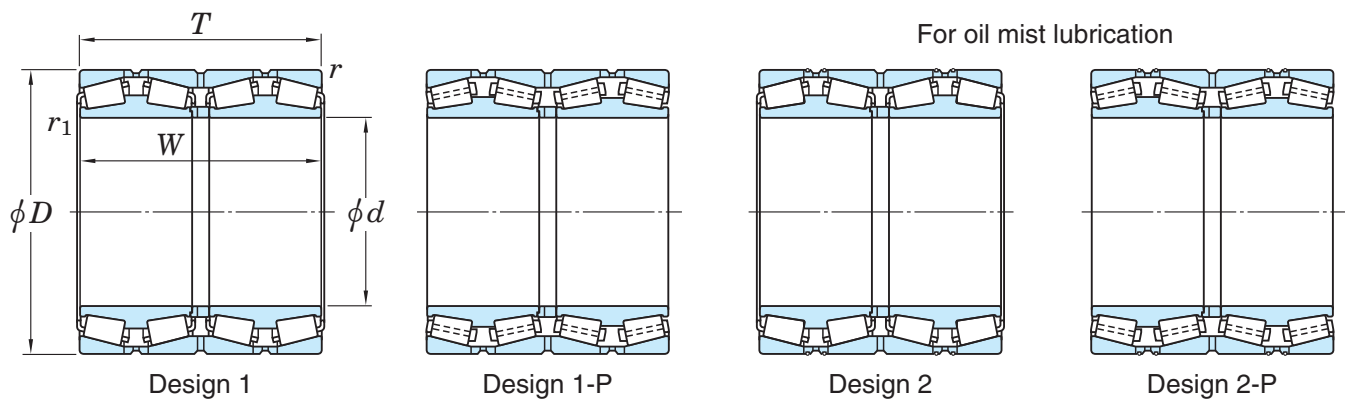

Boundary dimensions (mm)						Basic load ratings (kN)		Bearing No. ¹⁾
d	D	T	W	r min.	r_1 min.	C_r	C_{Or}	
206.375	282.575	184.150	184.150	3.2	0.8	1 200	2 830	67985D/20/20D
	282.575	190.500	190.500	3.2	0.8	1 200	2 830	67986D/20/21D
	282.575	210.000	210.000	3.2	0.8	1 380	3 010	47T412821A
215.090	311.150	228.600	228.600	3.2	1.6	1 750	4 040	47T433123
215.900	288.925	177.800	177.800	3.2	0.8	1 220	3 120	LM742749D/714/714D
	336.550	266.700	266.700	3.2	6.4	2 430	4 760	47T433427
216.103	330.200	269.875	263.525	3.2	1.6	2 500	5 120	47T433327
220	300	230	230	2.5	3	1 750	4 040	47T443023
	310	226	226	3	4	1 690	3 880	37244
	320	201	201	3	3	1 660	3 760	47T443220
	320	250	250	2.5	3	1 930	4 230	47T443225
	330	260	260	3	1	2 350	5 070	47T443326A
	330	260	260	3	1	2 330	4 860	47T443326B
	340	190	190	3	4	1 490	2 910	47244
	340	280	280	3	1	2 720	5 580	47T443428-1
340	305	305	3	4	2 910	5 940	47T443431	
220.662	314.325	290.000	290.000	3.2	1.6	2 300	5 050	47T443129A
220.663	314.325	239.713	239.713	3.2	1.6	2 100	4 890	M244249D/210/210D
225	320	230	230	2	2.5	1 670	3 730	4TR225A
228.600	311.150	200.025	200.025	3.2	1.6	1 660	3 760	LM245149D/110/110D
230	315	190	190	2	2.5	1 510	3 470	47T463119
234.950	327.025	196.850	196.850	3.2	1.6	1 600	3 720	8576D/20/20D
235	325	240	240	2.5	1.5	2 200	5 310	47T473324

[Notes] 1) While metric series bearings have minus tolerances for bore and OD, inch series have plus tolerances. Refer to page C 82 for details of applicable tolerance standards.

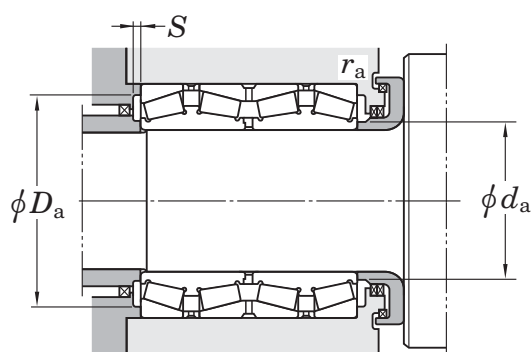

Design	Mounting dimensions (mm)							Con- stant <i>e</i>	Axial load factors			(Refer.) Mass (kg)
	<i>d_a</i> max.	<i>D_a</i> max.	<i>D_a</i> min.	<i>S</i> min.	<i>r_a</i> max.	<i>r_b</i> ²⁾ max.	<i>Y₂</i>		<i>Y₃</i>	<i>Y₀</i>		
1	219	270	259	7	3.2	0.8	0.51	1.33	1.97	1.30	33.9	
1	222	270	259	7	3.2	0.8	0.51	1.33	1.97	1.30	34.8	
1	219	270	260	3.5	3.2	0.8	0.43	1.57	2.34	1.53	36.2	
1	233	297	278	7	3.2	1.6	0.40	1.68	2.50	1.64	57.5	
1	229	276	265	5.5	3.2	0.8	0.48	1.40	2.09	1.37	32.8	
1	238	323	304	6.5	3.2	6.4	0.50	1.34	2.00	1.32	85.1	
1	237	316	300	7	3.2	1.6	0.46	1.47	2.19	1.44	81.6	
1	231	288	278	6.5	2	2.5	0.40	1.68	2.50	1.64	45.1	
1	242	296	285	6	2.5	3	0.33	2.03	3.02	1.98	52	
1	247	306	290	5.5	2.5	2.5	0.33	2.03	3.02	1.98	52.4	
1	244	308	293	6.5	2	2.5	0.35	1.95	2.90	1.91	64.7	
1	243	316	299	9	2.5	1	0.40	1.68	2.50	1.64	78.4	
2	238	316	300	8	2.5	1	0.55	1.24	1.84	1.21	77.5	
1	260	326	308	6	2.5	3	0.28	2.43	3.61	2.37	62.2	
1	247	326	308	10	2.5	1	0.33	2.03	3.02	1.98	95.1	
1	244	326	307	8	2.5	3	0.35	1.95	2.90	1.91	99.6	
1	240	300	289	4.5	3.2	1.6	0.33	2.03	3.02	1.98	70	
1	241	300	288	5	3.2	1.6	0.33	2.03	3.02	1.98	59	
1	246	310	293	5	2	2	0.37	1.80	2.69	1.76	57	
1	247	297	287	5.5	3.2	1.6	0.33	2.03	3.02	1.98	41.8	
1	248	305	290	7.5	2	2	0.37	1.80	2.69	1.76	43	
1	255	313	299	5.5	3.2	1.6	0.41	1.66	2.47	1.62	50.1	
1	254	313	301	8.5	2	1.5	0.33	2.03	3.02	1.98	60.5	

2) *r_b* indicates the shaft chamfer dimension corresponding to cone chamfer dimension *r₁*.

Four-row tapered roller bearings

d 240 ~ (260) mm

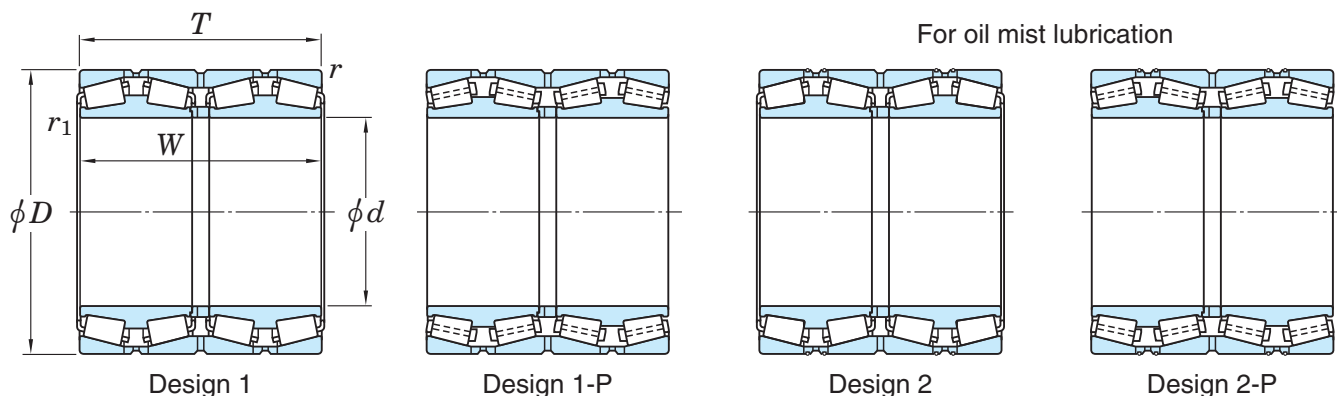

d	Boundary dimensions (mm)					Basic load ratings (kN)		Bearing No. ²⁾
	D	T	W	r min.	r_1 ¹⁾ min.	C_r	C_{Or}	
240	320	250	250	2	1	1 880	4 760	47T483225B
	338	248	248	3	4	2 360	5 360	37248
	338	248	248	3	4	2 360	5 360	37248/DP1
	360	194	194	3	4	1 830	3 580	47248
	360	214	214	3	2.5	2 170	4 340	47T483621
	360	308.5	308.5	3	2.5	3 320	7 400	47T483631A
	365	290	290	2	SP	2 870	5 930	47T483729
410	270	270	4	2.5	3 220	5 520	47T484127A	
241.478	349.148	228.600	228.600	3.2	1.6	2 190	4 920	47T483523A
	349.148	228.600	228.600	3.2	1.6	1 900	4 100	EE127097D/135/136D
244.475	327.025	193.675	193.675	3.2	1.6	1 470	3 500	47T493319
	327.025	193.675	193.675	3.2	1.6	1 570	3 780	LM247748D/710/710D
	381.000	304.800	304.800	4.8	3.2	2 700	5 870	EE126096D/150/151D
247.650	400.050	253.995	249.235	6.4	1.6	2 600	5 140	EE220975D/1575/1576D
250	350	240	240	2.5	1	2 180	4 970	47T503524
	365	270	270	3	1.5	2 650	6 340	47T503627
254.000	358.775	147.000	147.000	3.2	1.6	1 320	2 910	47T513615
	358.775	269.875	269.875	3.2	1.6	2 650	6 340	47T513627A
	358.775	269.875	269.875	3.2	1.6	2 630	6 030	47T513627B
	358.775	269.875	269.875	3.2	1.6	2 630	6 030	47T513627C
	358.775	269.875	269.875	3.2	3.2	2 650	6 340	M249748D/710/710D
260	360	272	272	3	1	2 910	7 020	47T523627A
	368	268	268	4	5	2 510	6 020	37252
	400	220	220	4	1.5	2 390	4 520	47T524022
	400	255	255	7.5	5	2 620	5 400	47T524026
	400	320	320	4	5	3 270	7 070	47T524032

[Notes] 1) SP indicates the specially chamfered form.

2) While metric series bearings have minus tolerances for bore and OD, inch series have plus tolerances. Refer to page C 82 for details of applicable tolerance standards.

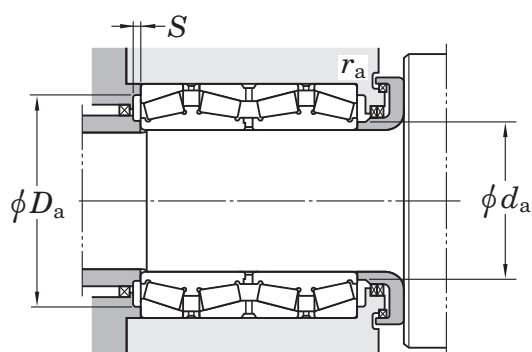

Design	Mounting dimensions (mm)							Constant e	Axial load factors			(Refer.) Mass (kg)
	d_a max.	D_a max.	D_a min.	S min.	r_a max.	r_b ³⁾ max.	Y_2		Y_3	Y_0		
1	257	310	299	7.5	2	1	0.33	2.03	3.02	1.98	54.2	
1	259	324	312	8.5	2.5	3	0.39	1.74	2.59	1.70	68.4	
2	259	324	312	8.5	2.5	3	0.39	1.74	2.59	1.70	68.4	
1	272	346	327	8.5	2.5	3	0.32	2.12	3.15	2.07	66.5	
1	268	346	328	9	2.5	2.5	0.40	1.68	2.50	1.64	75.4	
1	268	346	329	9.5	2.5	2.5	0.26	2.55	3.80	2.50	112	
1	265	355	333	9	2	0.8	0.46	1.47	2.19	1.44	108	
1	281	392	369	8.5	3	2	0.40	1.68	2.50	1.64	144	
1	267	335	319	8.5	3.2	1.6	0.35	1.91	2.84	1.86	72.9	
1	267	335	319	5.5	3.2	1.6	0.35	1.91	2.84	1.86	70.4	
1	259	313	303	5.5	3.2	1.6	0.55	1.24	1.84	1.21	44.4	
1	265	313	305	7.5	3.2	1.6	0.32	2.10	3.13	2.06	44.4	
1	269	364	336	6	4.8	3.2	0.52	1.31	1.95	1.28	129	
1	292	379	359	7.5	6.4	1.6	0.39	1.71	2.54	1.67	123	
1	270	338	324	6	2	1	0.40	1.68	2.50	1.64	70	
1	277	351	330	8	2.5	1.5	0.33	2.03	3.02	1.98	96.7	
1	290	345	331	7	3.2	1.6	0.33	2.03	3.02	1.98	46.9	
2	277	345	330	8	3.2	1.6	0.33	2.03	3.02	1.98	85.8	
1	272	345	331	7.5	3.2	1.6	0.46	1.47	2.19	1.44	85.5	
2	272	345	331	7.5	3.2	1.6	0.46	1.47	2.19	1.44	86.1	
1	277	345	330	8	3.2	3.2	0.33	2.03	3.02	1.98	86	
1	280	346	335	9	2.5	1	0.33	2.03	3.02	1.98	83.6	
1	286	350	338	6	3	4	0.33	2.03	3.02	1.98	88.4	
1	295	382	364	7.5	3	1.5	0.40	1.68	2.50	1.64	98.5	
1	296	400	360	9	6	4	0.39	1.72	2.56	1.68	113	
1	294	382	361	8.5	3	4	0.33	2.03	3.02	1.98	145	

3) r_b indicates the shaft chamfer dimension corresponding to cone chamfer dimension r_1 .

Four-row tapered roller bearings

d (260) ~ 288.925 mm

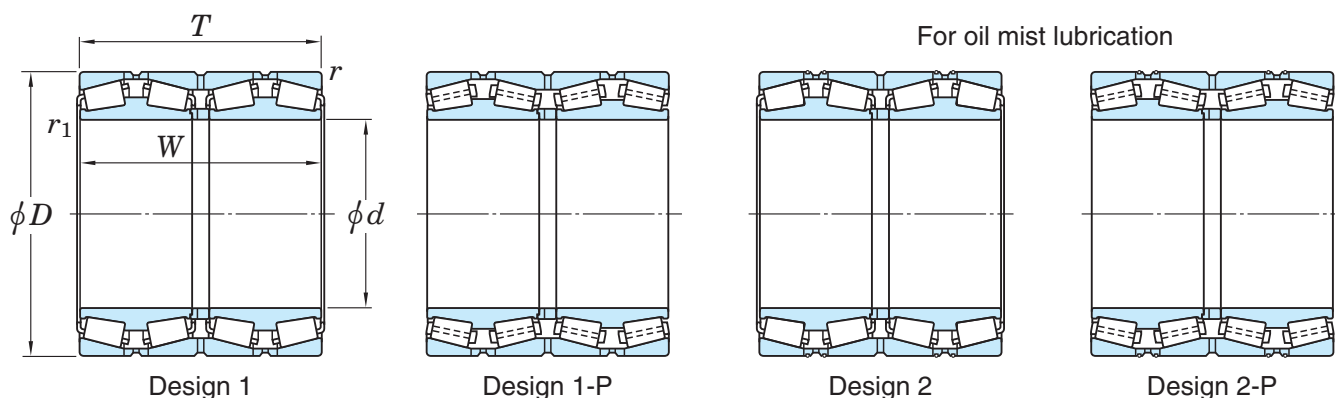

Boundary dimensions (mm)						Basic load ratings (kN)		Bearing No. ¹⁾
d	D	T	W	$r_{\min.}$	$r_{1\min.}$	C_r	C_{Or}	
260	440	300	300	4	5	3 470	6 880	47352
260.350	422.275	317.500	314.325	3.2	6.4	3 470	6 720	HM252348D/310/310D
266.700	335.600	228.600	230.188	3.2	1.6	1 850	5 260	47T533423
	355.600	228.600	230.188	3.2	1.6	2 230	5 690	47T533623B
	355.600	228.600	230.188	3.2	1.6	1 980	4 830	76589D/20/20D
	393.700	269.878	269.878	6.4	1.6	2 990	6 460	47T533927-1
269.875	381.000	282.575	282.575	3.2	3.2	2 930	6 690	M252349D/310/310D
270	364	260	260	3	1.5	2 370	5 720	47T543626
	410	222	222	4	5	2 250	4 380	47254
276.225	393.700	269.878	269.878	6.4	1.6	2 730	5 830	47T553927
279.400	393.700	269.875	269.875	6.4	1.6	2 660	5 990	47T563927A
	393.700	269.875	269.875	6.4	1.6	2 660	5 990	47T563927B
	410.000	310.000	310.000	6.4	1.6	3 120	7 290	47T564131
279.578	380.898	244.475	244.475	3.2	1.6	2 280	5 650	LM654644D/610/610D
280	380	290	290	2	2	2 810	6 940	47T563829
	380	290	290	2	1	2 810	6 940	47T563829A
	395	288	288	4	2	2 880	6 900	37256X
	395	288	288	4	2	2 880	6 900	47T564029A
	420	225	225	4	5	2 390	4 950	47256
	460	324	324	5	6	4 300	8 230	47T564632
280.268	379.887	244.475	244.475	3.2	1.6	2 280	5 650	47T563824
285.750	380.898	244.475	244.475	3.2	1.6	2 280	5 650	LM654648D/610/610D
288.925	406.400	298.450	298.450	3.2	3.2	3 450	8 840	M255449D/410/410D

[Notes] 1) While metric series bearings have minus tolerances for bore and OD, inch series have plus tolerances. Refer to page C 82 for details of applicable tolerance standards.

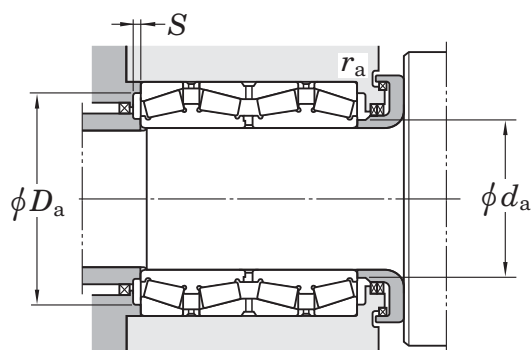

Design	Mounting dimensions (mm)							Constant e	Axial load factors			(Refer.) Mass (kg)
	d_a max.	D_a max.	D_a min.	S min.	r_a max.	r_b ²⁾ max.	Y_2		Y_3	Y_0		
1	311	422	392	10	3	4	0.35	1.95	2.90	1.91	188	
1	304	407	384	1	3.2	6.4	0.33	2.03	3.02	1.98	167	
1	281	322	312	7	3.2	1.6	0.28	2.43	3.61	2.37	46.4	
1	285	342	332	8	3.2	1.6	0.36	1.87	2.79	1.83	62.7	
1	285	342	331	7	3.2	1.6	0.37	1.83	2.73	1.79	59.8	
1	294	373	361	8.5	6.4	1.6	0.40	1.68	2.50	1.64	112	
1	291	367	350	6	3.2	3.2	0.33	2.03	3.02	1.98	98.4	
1	285	350	338	4.5	2.5	1.5	0.42	1.59	2.37	1.56	72.8	
1	308	392	372	6.5	3	4	0.27	2.51	3.74	2.45	100	
1	299	373	363	4.5	6.4	1.6	0.40	1.68	2.50	1.64	101	
2	305	373	363	9.5	6.4	1.6	0.40	1.68	2.50	1.64	101	
1	305	373	363	9.5	6.4	1.6	0.40	1.68	2.50	1.64	101	
2	308	389	374	8	6.4	1.6	0.40	1.68	2.50	1.64	140	
1	303	367	356	6.5	3.2	1.6	0.43	1.57	2.34	1.53	80.4	
1	300	370	354	6	2	2	0.33	2.03	3.02	1.98	91.8	
2	300	370	354	6	2	1	0.33	2.03	3.02	1.98	92.1	
1	303	377	363	8	3	2	0.40	1.68	2.50	1.64	110	
2	303	377	363	8	3	2	0.40	1.68	2.50	1.64	110	
1	322	402	382	8.5	3	4	0.25	2.69	4.00	2.63	104	
1-P	321	438	415	10.5	4	5	0.46	1.47	2.19	1.44	214	
1	303	366	355	6.5	3.2	1.6	0.43	1.57	2.34	1.53	80	
1	303	367	356	6.5	3.2	1.6	0.43	1.57	2.34	1.53	75.6	
1	316	392	373	9	3.2	3.2	0.34	2.00	2.97	1.95	127	

2) r_b indicates the shaft chamfer dimension corresponding to cone chamfer dimension r_1 .

Four-row tapered roller bearings

d 292.100 ~ (320) mm

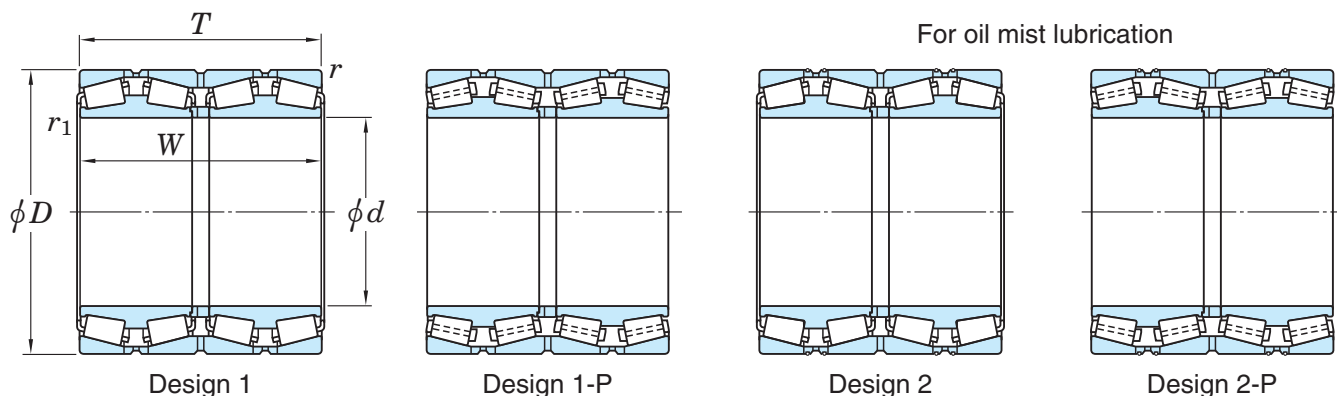

Boundary dimensions (mm)						Basic load ratings (kN)		Bearing No. ²⁾
d	D	T	W	r min.	r_1 ¹⁾ min.	C_r	C_{Or}	
292.100	422.275	269.875	269.875	3.2	6.4	3 170	6 830	EE330116D/166/167D
300	420	310	310	3	1	3 390	8 050	47T604231
	424	310	310	4	5	3 000	6 570	37260
	430	300	300	3	4	3 320	7 630	47T604330
	430	310	310	3	2.5	3 520	8 420	47T604331
	460	248	248	4	1.5	3 060	6 300	47T604625
	460	360	360	4	5	4 300	9 550	47T604636
	470	270	270	4	5	3 500	6 440	47T604727A
	470	292	292	4	SP	3 980	7 870	47T604729B
	470	292	292	4	1.5	4 120	8 210	47T604729C
500	350	350	4	2.5	5 010	9 290	47T605035	
300.038	422.275	311.150	311.150	3.2	3.2	3 390	8 050	HM256849D/810/810D
304.648	438.048	279.400	280.990	4.8	3.2	3 230	6 980	47T614428C
	438.048	279.400	280.990	4.8	3.2	3 230	6 980	M757448D/410/410D
304.800	419.100	269.875	269.875	6.4	1.6	2 840	6 950	M257149D/110/110D
	482.600	377.825	365.125	6.4	3.2	4 820	9 800	47T614838A
	495.300	349.250	342.900	6.4	3.2	4 370	9 370	EE724121D/195/196D
304.902	412.648	266.7	266.7	3.2	3.2	2 990	7 280	M257248D/210/210D
310	430	310	310	3	3	3 520	8 420	47T624331A
	460	325	325	4	5	4 200	9 500	47T6246A
317.500	422.275	269.875	269.875	3.2	1.6	2 930	7 450	LM258649D/610/610D
	447.675	327.025	327.025	6.4	1.6	4 120	9 820	47T644533J
	447.675	327.025	327.025	6.4	1.6	4 280	10 100	47T644533L
320	440	335	335	2	2.5	3 590	8 750	47T644434

[Notes] 1) SP indicates the specially chamfered form.

2) While metric series bearings have minus tolerances for bore and OD, inch series have plus tolerances. Refer to page C 82 for details of applicable tolerance standards.

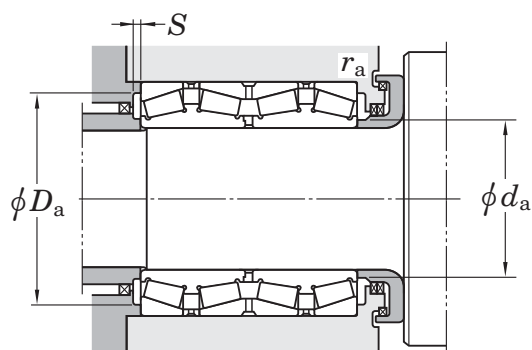

Design	Mounting dimensions (mm)							Constant <i>e</i>	Axial load factors			(Refer.) Mass (kg)
	<i>d_a</i> max.	<i>D_a</i> max.	<i>D_a</i> min.	<i>S</i> min.	<i>r_a</i> max.	<i>r_b</i> ³⁾ max.	<i>Y₂</i>		<i>Y₃</i>	<i>Y₀</i>		
1	321	407	387	7.5	3.2	6.4	0.32	2.11	3.14	2.06	124	
1	325	406	388	8.5	2.5	1	0.34	2.00	2.98	1.96	132	
1	334	406	391	6	3	4	0.28	2.37	3.53	2.32	134	
1	328	416	393	10	2.5	3	0.35	1.95	2.90	1.91	141	
1	332	416	399	10	2.5	2	0.40	1.68	2.50	1.64	146	
1	342	442	416	8.5	3	1.5	0.40	1.68	2.50	1.64	149	
1	339	442	416	9	3	4	0.33	2.03	3.02	1.98	220	
1	338	452	426	8	3	4	0.40	1.68	2.50	1.64	165	
1-P	341	452	428	8.5	3	2	0.40	1.68	2.50	1.64	193	
1-P	343	452	428	9.5	3	1.5	0.33	2.03	3.02	1.98	198	
1	346	482	451	8	3	2	0.40	1.68	2.50	1.64	270	
1	325	407	388	7	3.2	3.2	0.34	2.00	2.98	1.96	136	
2	331	420	403	7	4.8	3.2	0.47	1.44	2.15	1.41	133	
1	331	420	403	7	4.8	3.2	0.47	1.44	2.15	1.41	132	
1	331	398	387	7	6.4	1.6	0.33	2.03	3.02	1.98	110	
1-P	343	461	437	1	6.4	3.2	0.47	1.43	2.12	1.40	250	
1	355	474	438	7	6.4	3.2	0.40	1.68	2.50	1.64	267	
1	328	398	383	7	3.2	3.2	0.32	2.12	3.15	2.07	101	
1	332	416	399	10	2.5	2.5	0.40	1.68	2.50	1.64	135	
1	346	442	421	12	3	4	0.32	2.12	3.15	2.07	188	
1	341	407	392	8.5	3.2	1.6	0.32	2.12	3.15	2.07	104	
1-P	341	426	411	7.5	6.4	1.6	0.33	2.02	3.00	1.97	161	
1	344	426	411	11.5	6.4	1.6	0.33	2.03	3.02	1.98	161	
1	341	430	408	5.5	2	2	0.40	1.68	2.50	1.64	149	

3) *r_b* indicates the shaft chamfer dimension corresponding to cone chamfer dimension *r₁*.

Four-row tapered roller bearings

d (320) ~ (355.600) mm

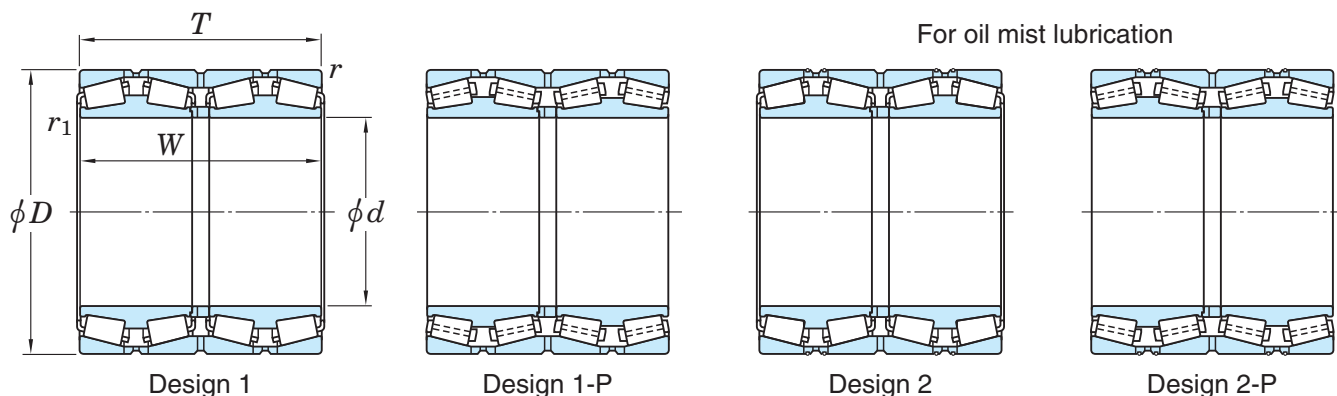

d	Boundary dimensions (mm)					Basic load ratings (kN)		Bearing No. ¹⁾
	D	T	W	r min.	r_1 min.	C_r	C_{Or}	
320	460	325	325	4	2.5	4 030	9 420	47T644633
	460	338	338	4	5	3 500	8 590	37264
	480	254	254	4	2.5	3 400	6 940	47T644825
	480	260	260	4	5	3 360	6 890	47T644826
	480	360	360	4	1	4 970	11 000	47T644836-1
	500	380	380	4	1.5	5 540	11 900	47T645038
	540	364	364	5	6	5 380	10 600	47364
325	430	230	230	3	1	2 410	5 800	47T654323
327	445	230	230	3	1	2 620	6 080	47T654523
330.200	444.500	301.625	301.625	3.2	3.2	3 550	9 260	47T664430
	508.000	307.975	307.975	6.4	1.6	4 320	8 500	47T665131A
335.000	460.000	342.900	342.900	3.2	1.6	3 960	9 390	47T674634/DP
337.375	469.900	342.900	342.900	3.2	1.6	4 630	11 400	HM261049D/010/010D
340	480	350	350	5	6	4 700	11 700	37268A
	520	278	278	5	6	4 040	8 110	47T685228
	520	323	323	5	6	4 380	8 930	47T685232
343.052	457.098	254.000	254.000	3.2	1.6	2 850	6 950	47T694625
	457.098	254.000	254.000	3.2	1.6	2 850	6 950	47T694625/DP3
346.075	488.950	358.775	358.775	3.2	3.2	4 620	11 600	HM262749D/10/10D
347.663	469.900	292.100	292.100	3.2	3.2	3 600	9 040	M262449D/10/10D
355	490	316	316	2	2.5	4 160	10 000	47T714932
355.600	482.600	269.875	265.113	3.2	1.6	3 390	7 860	47T714827-1
	482.600	269.875	265.112	3.2	1.6	3 060	7 020	LM763449D/410/410D

[Notes] 1) While metric series bearings have minus tolerances for bore and OD, inch series have plus tolerances. Refer to page C 82 for details of applicable tolerance standards.

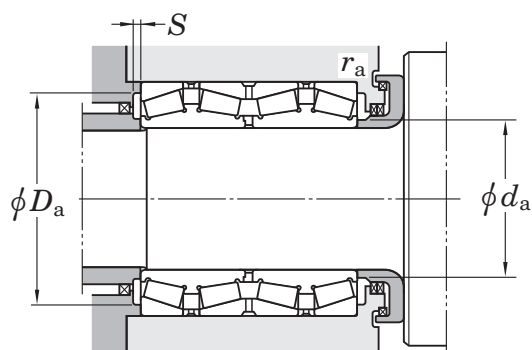

Design	Mounting dimensions (mm)							Constant <i>e</i>	Axial load factors			(Refer.) Mass (kg)
	<i>d_a</i> max.	<i>D_a</i> max.	<i>D_a</i> min.	<i>S</i> min.	<i>r_a</i> max.	<i>r_b</i> ²⁾ max.	<i>Y₂</i>		<i>Y₃</i>	<i>Y₀</i>		
1	349	442	424	10	3	2.5	0.42	1.62	2.42	1.59	175	
1	356	442	421	8.5	3	4	0.33	2.03	3.02	1.98	183	
1-P	358	462	437	9	3	2	0.40	1.68	2.50	1.64	161	
1	359	462	437	11.5	3	5	0.40	1.68	2.50	1.64	165	
1-P	352	462	442	9	3	1	0.47	1.43	2.12	1.40	229	
1-P	363	482	454	11.5	3	1.5	0.33	2.03	3.02	1.98	284	
1	376	518	479	8.5	4	5	0.32	2.12	3.15	2.07	340	
1	347	416	401	8.5	2.5	1	0.40	1.68	2.50	1.64	88.5	
1	353	431	413	9	2.5	1	0.40	1.68	2.50	1.64	102	
1	357	430	414	10	3.2	3.2	0.26	2.55	3.80	2.50	134	
1	372	486	462	8	6.4	1.6	0.33	2.03	3.02	1.98	219	
2	361	445	428	7.5	3.2	1.6	0.40	1.68	2.50	1.64	165	
1-P	360	455	432	9	3.2	1.6	0.33	2.02	3.01	1.97	190	
1-P	371	458	443	9.5	4	6	0.33	2.03	3.02	1.98	198	
1	384	498	473	9	4	6	0.40	1.68	2.50	1.64	212	
1	381	498	473	10	4	5	0.40	1.68	2.50	1.64	242	
1	363	442	425	6	3.2	1.6	0.47	1.43	2.12	1.40	111	
2	363	442	425	6	3.2	1.6	0.47	1.43	2.12	1.40	111	
1	378	474	449	8	3.2	3.2	0.33	2.02	3.00	1.97	214	
1	374	455	436	10	3.2	3.2	0.33	2.03	3.02	1.98	145	
1	385	480	455	12.5	2	2	0.33	2.03	3.02	1.98	180	
1	386	468	450	8	3.2	1.6	0.26	2.55	3.80	2.50	139	
1	381	468	450	3.5	3.2	1.6	0.47	1.43	2.14	1.40	136	

2) *r_b* indicates the shaft chamfer dimension corresponding to cone chamfer dimension *r₁*.

Four-row tapered roller bearings

d (355.600) ~ (380) mm

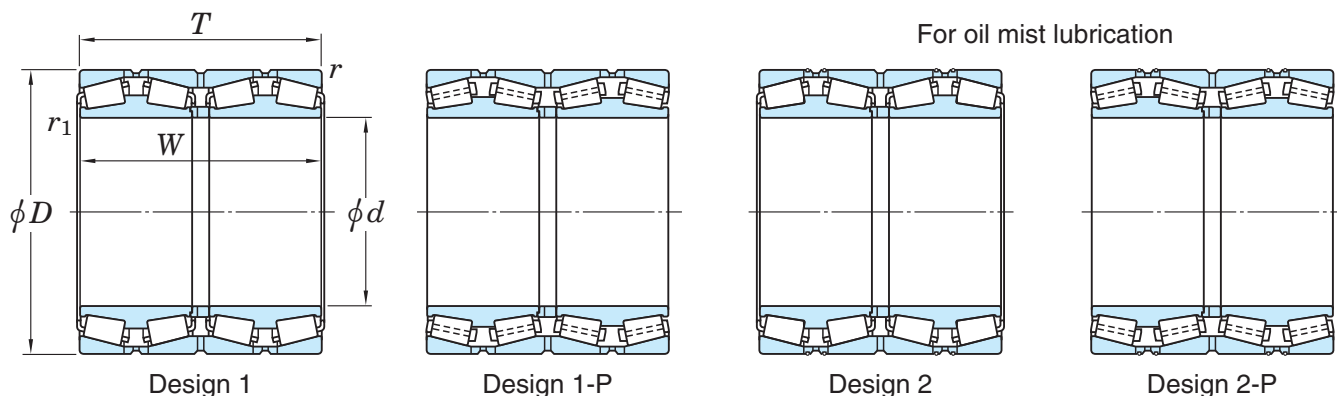

Boundary dimensions (mm)						Basic load ratings (kN)		Bearing No. ¹⁾
d	D	T	W	r min.	r_1 min.	C_r	C_{Or}	
355.600	488.950	317.500	317.500	3.2	1.6	4 370	10 900	M263349D/310/310D
360	480	375	375	3	4	3 930	9 910	47T724838A
	480	375	375	3	1	4 190	11 100	47T724838C
	508	370	370	5	6	4 840	11 500	47T725137
	520	370	370	5	6	4 920	11 400	47T725237
	520	410	410	5	6	5 970	14 300	47T725241
	540	280	280	5	6	3 790	7 820	47272
	540	280	280	5	6	3 760	8 000	47T725428
	540	460	460	4	5	6 440	15 800	47T7254
368.300	523.875	382.588	382.588	6.4	3.2	5 530	13 600	47T745238B
	523.875	382.588	382.588	3.2	1.6	5 620	14 100	47T745238D
	523.875	382.588	382.588	6.4	3.2	5 920	14 500	47T745238J
	523.875	382.588	382.588	6.4	3.2	5 460	13 600	HM265049D/010/010D
	563.000	382.588	382.588	6.4	3.2	6 300	13 600	47T745638
370	516	346	346	4	1.5	4 880	11 700	47T745235
374.650	501.650	260.350	260.350	3.2	1.6	2 930	7 750	47T745026
380	520	360	360	5	6	4 610	12 200	47T765236
	520	400	400	4	2.5	5 020	13 000	47T765240
	536	390	390	5	6	5 760	12 900	37276
	560	282	282	5	6	3 670	7 580	47276
	560	285	285	4	5	4 600	10 000	47T765629
	560	285	285	4	5	4 420	9 240	47T765629A
	560	325	325	5	6	5 330	11 900	47T765633A
	560	360	390	4	1.5	5 310	11 800	47T765639
	560	370	370	5	6	5 910	13 600	47T765637
	580	500	500	5	6	7 410	17 500	47T765850

[Notes] 1) While metric series bearings have minus tolerances for bore and OD, inch series have plus tolerances. Refer to page C 82 for details of applicable tolerance standards.

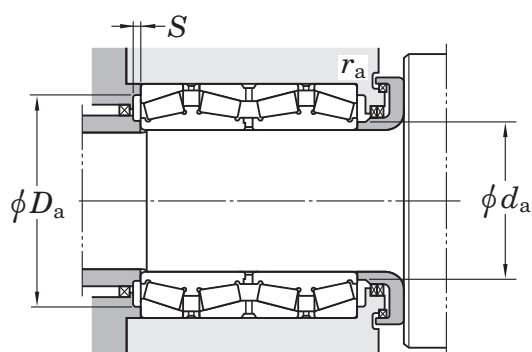

Design	Mounting dimensions (mm)							Constant <i>e</i>	Axial load factors			(Refer.) Mass (kg)
	<i>d_a</i> max.	<i>D_a</i> max.	<i>D_a</i> min.	<i>S</i> min.	<i>r_a</i> max.	<i>r_b</i> ²⁾ max.	<i>Y₂</i>		<i>Y₃</i>	<i>Y₀</i>		
1-P	383	474	452	7.5	3.2	1.6	0.33	2.03	3.02	1.98	182	
1	383	466	446	3.5	2.5	3	0.40	1.68	2.50	1.64	177	
1	381	466	448	5	2.5	1	0.33	2.03	3.02	1.98	183	
1	392	486	471	7	4	6	0.33	2.03	3.02	1.98	232	
1	395	498	476	8.5	4	5	0.33	2.03	3.02	1.98	259	
1-P	395	498	479	8.5	4	5	0.33	2.03	3.02	1.98	292	
1	406	518	490	10	4	5	0.32	2.12	3.15	2.07	221	
1	402	518	489	10.5	4	5	0.55	1.24	1.84	1.21	224	
1	408	522	492	9.5	3	4	0.27	2.47	3.67	2.41	373	
1-P	404	502	483	9	6.4	3.2	0.29	2.32	3.45	2.26	269	
1	403	508	483	7.5	3.2	1.6	0.33	2.03	3.02	1.98	265	
1-P	401	502	485	10.5	6.4	3.2	0.33	2.03	3.02	1.98	268	
1-P	403	502	483	7	6.4	3.2	0.33	2.03	3.02	1.98	269	
1-P	417	541	516	10.5	6.4	3.2	0.29	2.32	3.45	2.26	344	
1-P	398	498	479	9	3	1.5	0.40	1.68	2.50	1.64	216	
1	399	486	459	7	3.2	1.6	0.43	1.56	2.32	1.52	145	
1	417	498	484	11	4	5	0.32	2.12	3.15	2.07	225	
1	404	502	482	9.5	3	2	0.40	1.68	2.50	1.64	248	
1	415	514	496	7.5	4	5	0.40	1.68	2.50	1.64	268	
1	429	538	511	9	4	5	0.27	2.47	3.67	2.41	232	
1-P	428	542	513	11	3	4	0.27	2.47	3.67	2.41	246	
1	427	542	515	11	3	5	0.27	2.47	3.67	2.41	244	
1-P	427	538	514	11	4	5	0.27	2.47	3.67	2.41	278	
1	422	542	514	9	3	1.5	0.35	1.95	2.90	1.91	307	
1-P	423	538	515	10	4	5	0.33	2.03	3.02	1.98	312	
1	427	558	529	10.5	4	5	0.33	2.03	3.02	1.98	478	

2) *r_b* indicates the shaft chamfer dimension corresponding to cone chamfer dimension *r₁*.

Four-row tapered roller bearings

d (380) ~ 430 mm

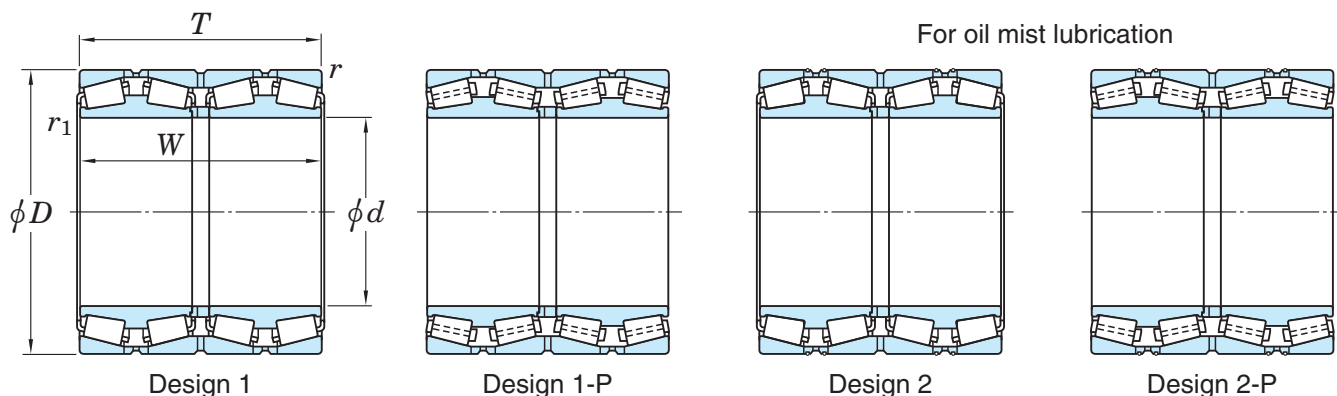

Boundary dimensions (mm)						Basic load ratings (kN)		Bearing No. ¹⁾
d	D	T	W	r min.	r_1 min.	C_r	C_{Or}	
380	620	400	400	5	6	6 130	12 700	47376 47T766242
	620	418.5	418.5	5	6	7 080	14 000	
384.175	546.100	400.050	400.050	6.4	3.2	6 530	16 900	HM266449D/410/410D 47T775547
	546.100	470.000	470.000	6.4	3.2	6 220	16 200	
390	510	350	350	3	1.5	4 300	11 700	47T785135A 47T785135B
	510	350	350	3	1	4 150	11 200	
395	545	288.7	270.3	7.5	5	3 330	7 680	47T795529
400	560	380	380	4	1.5	5 970	15 200	47T805638A 47T805641 47T805930A 47280
	564	412	412	4	2.5	6 470	16 500	
	590	304	304	4	1.5	4 760	10 200	
	600	308	308	5	6	4 810	9 930	
406.400	546.100	288.925	288.925	6.4	1.6	3 960	9 540	47T815529 47T815533B 47T815638 M267949D/910/910XD
	546.100	330.000	330.000	6.4	3.2	4 800	12 400	
	562.000	381.000	381.000	6.4	3.2	5 990	15 000	
	565.150	381.000	381.000	6.4	3.2	5 990	15 000	
409.575	546.100	334.963	334.963	6.4	1.6	4 570	11 500	M667947D/911/911D
415.925	590.550	434.975	434.975	6.4	3.2	7 060	18 800	47T835943A
420	560	370	370	5	6	4 950	13 600	47T845637 47T845644 37284 47284 47T846546
	560	437	437	4	1.5	5 620	14 900	
	592	432	432	5	6	6 030	15 700	
	620	312	312	5	6	4 810	10 400	
	650	460	460	6	6	8 560	18 300	
430	570	336	336	4	1.5	4 790	12 500	47T865734C 47T865738
	570	380	380	4	1.5	5 640	15 900	

[Notes] 1) While metric series bearings have minus tolerances for bore and OD, inch series have plus tolerances. Refer to page C 82 for details of applicable tolerance standards.

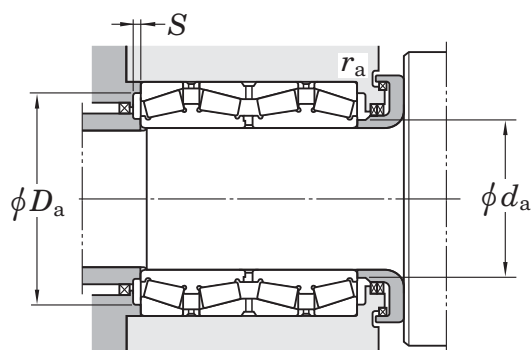

Design	Mounting dimensions (mm)							Constant e	Axial load factors			(Refer.) Mass (kg)
	d_a max.	D_a max.	D_a min.	S min.	r_a max.	r_b ²⁾ max.	Y_2		Y_3	Y_0		
1 1-P	445	598	552	6.5	4	5	0.32	2.12	3.15	2.07	476	
	435	598	561	10	4	5	0.46	1.47	2.19	1.44	499	
1-P 1	418	524	502	10.5	6.4	3.2	0.33	2.03	3.02	1.98	315	
	418	524	503	7.5	6.4	3.2	0.33	2.03	3.02	1.98	360	
1 1	413	496	478	10.5	2.5	1.5	0.33	2.03	3.02	1.98	186	
	415	496	479	5.5	2.5	1	0.29	2.32	3.45	2.26	183	
1	433	509	494	3	6	4	0.43	1.57	2.34	1.53	190	
1-P 1-P 1-P 1	435	542	519	10	3	1.5	0.33	2.03	3.02	1.98	296	
	432	546	522	9	3	2.5	0.40	1.68	2.50	1.64	329	
	449	572	540	7.5	3	1.5	0.33	2.03	3.02	1.98	289	
	452	578	548	9	4	5	0.33	2.03	3.02	1.98	310	
1 1-P 1 1	435	524	509	9.5	6.4	1.6	0.47	1.43	2.12	1.40	184	
	434	524	509	8.5	6.4	3.2	0.40	1.68	2.50	1.64	214	
	439	540	524	9.5	6.4	3.2	0.33	2.03	3.02	1.98	284	
	438.3	544	524	9.5	6.4	3.2	0.33	2.03	3.02	1.98	291	
1	432	524	509	8.5	6.4	1.6	0.42	1.62	2.42	1.59	213	
1-P	455	568	543	10	6.4	3.2	0.33	2.03	3.02	1.98	391	
1 1 1 1 1	459	538	527	12	4	5	0.32	2.12	3.15	2.07	252	
	450	542	526	4	3	1.5	0.26	2.55	3.80	2.50	283	
	460	570	544	7.5	4	5	0.33	2.03	3.02	1.98	374	
	473.5	598	567	10	4	5	0.33	2.03	3.02	1.98	328	
	468	622	595	8.5	5	5	0.40	1.68	2.50	1.64	558	
1 1	460	552	536	10	3	1.5	0.36	1.87	2.79	1.83	232	
	463	552	534	10.5	3	1.5	0.26	2.55	3.80	2.50	269	

2) r_b indicates the shaft chamfer dimension corresponding to cone chamfer dimension r_1 .

Four-row tapered roller bearings

d 431.800 ~ 475.000 mm

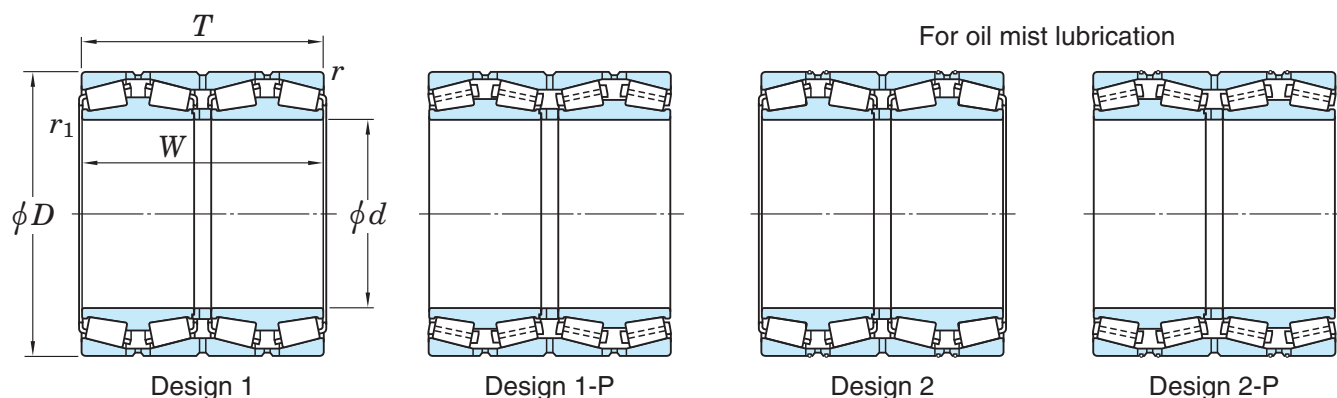

Boundary dimensions (mm)						Basic load ratings (kN)		Bearing No. ¹⁾
d	D	T	W	r min.	r_1 min.	C_r	C_{Or}	
431.800	571.500	336.550	336.550	6.4	1.6	5 070	13 500	47T865734 LM769349D/310/310D EE931170D/250/251XD
	571.500	336.550	336.550	6.4	1.6	4 290	11 300	
	635.000	355.600	355.600	6.4	6.4	6 310	13 700	
432.003	609.524	317.500	317.500	6.4	3.6	5 210	12 100	EE736173D/238/239D
440	580	420	420	4	1.5	5 730	15 400	47T885842 37288 47T886246 47T886443 47T886447 47288 47288A 47T886645
	620	454	454	6	6	7 110	17 500	
	620	454	454	4	5	7 610	19 800	
	635	430	430	5	6	7 560	18 000	
	635	470	470	5	2.5	8 510	20 900	
	650	326	326	6	6	5 080	11 000	
	650	334	334	6	6	5 490	12 200	
660	450	450	5	2	8 690	19 000		
447.675	635.000	463.550	463.550	6.4	3.2	7 860	21 000	M270749D/710/710D
449.949	594.949	368.000	368.000	5	2.5	5 980	16 200	M270449D/10/10D
450	580	450	450	6	1.5	5 130	14 600	47T905845
457.200	596.900	279.400	276.225	3.2	1.6	4 260	11 400	47T916028A EE737179D/260/261D
	660.400	323.847	323.850	6.4	3.2	5 700	12 700	
460	586	280	280	3	1	3 710	9 810	47T925928 47T926236 47T926342 37292 47T926838 47T927344
	615	360	360	3	1	5 000	13 300	
	625	421	421	4	1.5	6 920	18 800	
	650	474	474	6	6	7 680	19 400	
	680	375	375	5	2	6 500	15 200	
	730	440	440	6	3	8 650	17 700	
475.000	600.000	368.000	368.000	4.8	1.6	4 970	15 100	47T956037A

[Notes] 1) While metric series bearings have minus tolerances for bore and OD, inch series have plus tolerances. Refer to page C 82 for details of applicable tolerance standards.

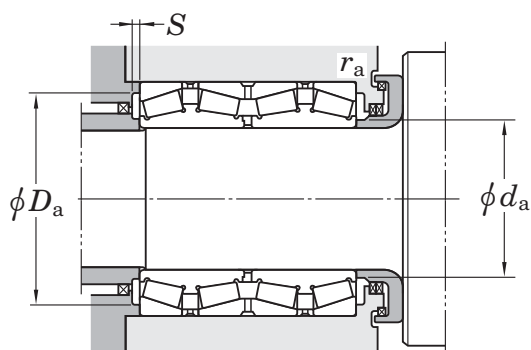

Design	Mounting dimensions (mm)							Con- stant <i>e</i>	Axial load factors			(Refer.) Mass (kg)
	<i>d_a</i> max.	<i>D_a</i> max.	<i>D_a</i> min.	<i>S</i> min.	<i>r_a</i> max.	<i>r_b</i> ²⁾ max.	<i>Y₂</i>		<i>Y₃</i>	<i>Y₀</i>		
1-P	460	549	534	10	6.4	1.6	0.36	1.87	2.79	1.83	232	
1	463	549	534	7	6.4	1.6	0.48	1.41	2.10	1.38	231	
1-P	481	612	586	8	6.4	6.4	0.32	2.10	3.13	2.06	385	
1-P	474	586	562	9	6.4	3.6	0.35	1.94	2.89	1.90	291	
1-P	467	562	544	1.5	3	1.5	0.26	2.55	3.80	2.50	288	
1	482	592	576	9	5	5	0.40	1.68	2.50	1.64	417	
1-P	474	602	573	10.5	3	5	0.40	1.68	2.50	1.64	436	
1-P	485	613	587	9.5	4	5	0.33	2.03	3.02	1.98	450	
1-P	483	613	588	10.5	4	2	0.33	2.03	3.02	1.98	500	
1-P	500	622	595	11	5	5	0.28	2.43	3.61	2.37	361	
1	500	622	595	9.5	5	5	0.28	2.43	3.61	2.37	375	
1	489	638	610	9.5	4	2	0.32	2.12	3.15	2.07	532	
1-P	491	612	584	8	6.4	3.2	0.33	2.03	3.02	1.98	472	
1-P	478	573	557	9	5	2	0.33	2.03	3.02	1.98	278	
1	475	552	537	2	5	1.5	0.26	2.55	3.80	2.50	286	
1-P	485	581	560	8.5	3.2	1.6	0.47	1.43	2.12	1.40	307	
1-P	501	637	603	9	6.4	3.2	0.37	1.80	2.69	1.76	365	
1	483	572	555	10.5	2.5	1	0.44	1.52	2.26	1.49	177	
1	490	601	572	8	2.5	1	0.47	1.43	2.12	1.40	292	
1-P	495	607	582	8	3	1.5	0.33	2.03	3.02	1.98	386	
1	500	622	598	8	5	5	0.33	2.03	3.02	1.98	495	
1	515	658	618	10.5	4	2	0.36	1.87	2.79	1.83	475	
1-P	519	702	662	13	5	2.5	0.47	1.43	2.12	1.40	710	
1	501	581	566	10.5	4.8	1.6	0.26	2.55	3.80	2.50	246	

2) *r_b* indicates the shaft chamfer dimension corresponding to cone chamfer dimension *r₁*.

Four-row tapered roller bearings

d 479.425 ~ 500 mm

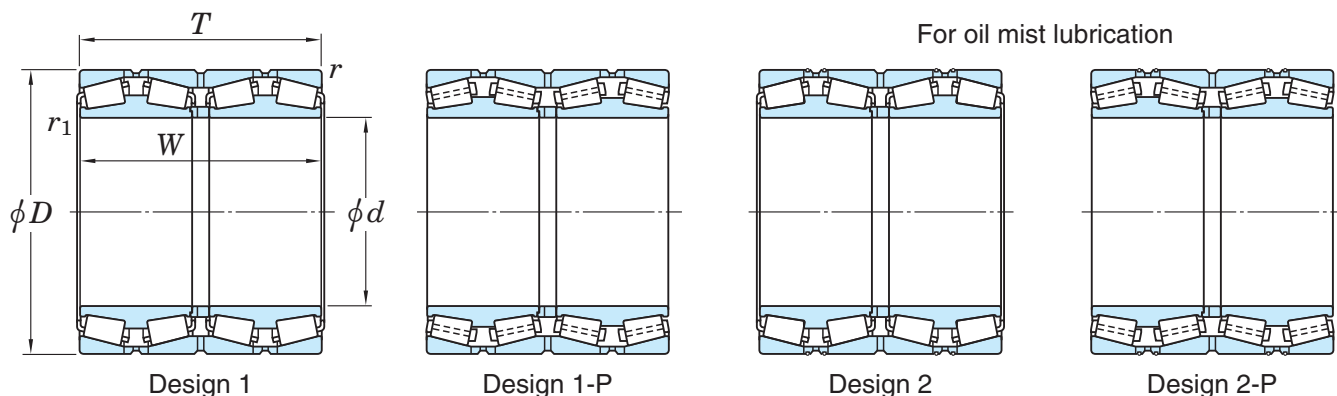

Boundary dimensions (mm)						Basic load ratings (kN)		Bearing No. ²⁾	
d	D	T	W	r min.	r_1 ¹⁾ min.	C_r	C_{Or}		
479.425	679.450	495.300	495.300	6.4	3.2	9 660	25 400	47T966850	
	679.450	495.300	495.300	6.4	3.2	8 480	22 200	M272749D/710/710D	
480	678	494	494	6	6	9 160	23 300	37296	
	700	390	390	5	6	7 400	16 800	47T967039	
480.000	700.000	420.000	420.000	6.4	3.2	8 060	18 800	47T967042C	
482.600	615.950	330.200	330.200	6.4	6.4	4 830	13 400	47T976233	
	615.950	330.200	330.200	6.4	6.4	4 830	13 400	4TR19A	
	615.950	330.200	330.200	6.4	4.8	5 270	15 000	4TR19B	
	615.950	330.200	330.200	6.4	3.2	5 210	15 000	4TR19D	
	615.950	420.000	420.000	4	2.5	5 810	16 700	47T976242	
	647.700	417.512	417.512	6.4	3.2	7 390	20 300	47T976542A	
	647.700	417.512	417.512	6.4	3.2	7 390	20 300	M272647D/610/610D	
488.950	622.300	365.125	365.125	3.6	3.6	4 950	13 900	47T986236	
	660.400	361.950	365.125	6.4	7.9	6 200	15 800	EE640193D/260/261D	
489.026	634.873	320.675	320.675	3.2	3.2	4 520	13 200	EE243193D/250/251D	
	634.873	320.675	320.675	3.2	3.2	4 930	13 700	LM772749D/710/710D	
490	625	385	385	4	1.5	5 690	17 200	47T986339A	
	625	385	385	4	1.5	5 540	16 600	47T986339B	
500	640	450	450	4	1.5	7 050	20 300	4TR500M	
	670	515	515	5	6	9 110	25 700	4TR500B	
	705	515	515	6	SP	9 530	24 500	372/500	
	710	430	425	5	3	8 170	20 000	4TR500T	
	720	400	400	6	6	7 990	18 700	4TR500J	
	760	420	420	2	6	8 730	19 300	4TR500Q	

[Notes] 1) SP indicates the specially chamfered form.

2) While metric series bearings have minus tolerances for bore and OD, inch series have plus tolerances. Refer to page C 82 for details of applicable tolerance standards.

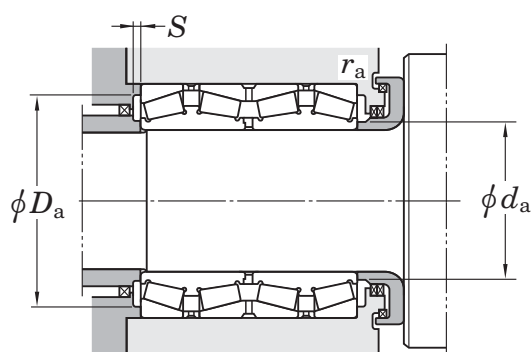

Design	Mounting dimensions (mm)							Constant e	Axial load factors			(Refer.) Mass (kg)
	d_a max.	D_a max.	D_a min.	S min.	r_a max.	r_b ³⁾ max.	Y_2		Y_3	Y_0		
1-P	523	656	641	12.5	6.4	3.2	0.33	2.03	3.02	1.98	591	
1-P	524	656	627	7.5	6.4	3.2	0.33	2.03	3.02	1.98	575	
1-P	520	650	629	9.5	5	5	0.33	2.03	3.02	1.98	563	
1-P	536	678	647	11	4	6	0.33	2.03	3.02	1.98	508	
1	531	677	644	10.5	6.4	3.2	0.35	1.95	2.90	1.91	540	
2-P	512	593	573	6	6.4	6.4	0.44	1.54	2.30	1.51	240	
1-P	512	593	573	6.5	6.4	6.4	0.44	1.54	2.30	1.51	240	
1-P	509	593	573	10.5	6.4	4.8	0.33	2.03	3.02	1.98	243	
1	508	593	573	10	6.4	3.2	0.36	1.87	2.79	1.83	240	
1	508	597	577	6	4	2.5	0.26	2.55	3.80	2.50	296	
2-P	514	624	603	9.5	6.4	3.2	0.33	2.03	3.02	1.98	397	
1-P	514	624	604	9.5	6.4	3.2	0.33	2.03	3.02	1.98	395	
1	516	605	585	7.5	3.6	3.6	0.33	2.03	3.02	1.98	262	
1-P	527	637	616	11	6.4	7.9	0.31	2.20	3.27	2.15	357	
1	526	618	595	9.5	3.2	3.2	0.34	1.97	2.93	1.93	263	
1	513	618	594	9.5	3.2	3.2	0.47	1.43	2.12	1.40	261	
1	520	607	587	9.5	3	1.5	0.28	2.43	3.61	2.37	290	
1	517	607	587	4.5	3	1.5	0.32	2.12	3.15	2.07	285	
2-P	527	622	602	10.5	3	1.5	0.24	2.84	4.23	2.78	352	
1-P	530	648	626	11	4	5	0.32	2.12	3.15	2.07	510	
1-P	544	677	651	8.5	5	6	0.37	1.80	2.69	1.76	641	
1	547	688	658	12	4	3	0.37	1.80	2.69	1.76	528	
1-P	552	692	663	12.5	5	5	0.33	2.03	3.02	1.98	547	
1-P	566	750	696	11.5	2	6	0.39	1.74	2.59	1.70	698	

3) r_b indicates the shaft chamfer dimension corresponding to cone chamfer dimension r_1 .

Sealed type four-row tapered roller bearings

d 75 ~ 234.950 mm

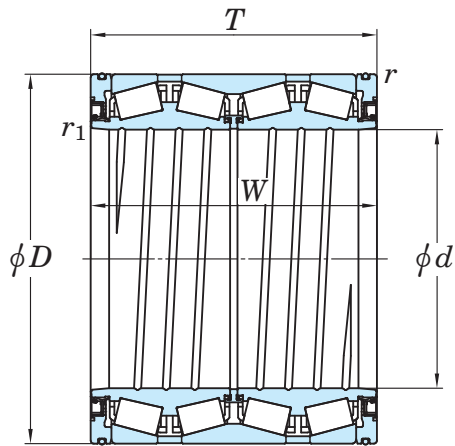

Design 1

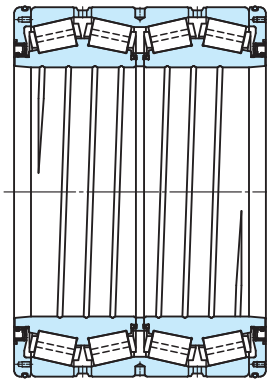

Design 1-P

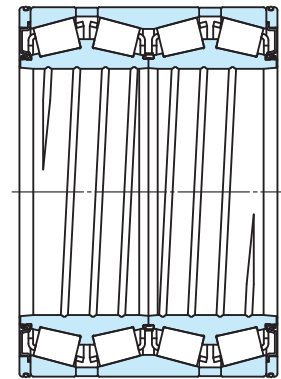

Design 2

Boundary dimensions										Basic load ratings (kN)	
d		D		T		W		$r^{1)}$	$r_1^{1)}$	C_r	C_{0r}
mm	1/25.4	mm	1/25.4	mm	1/25.4	mm	1/25.4	min.	min.		
75	—	120	—	150	—	150	—	2	1	424	764
	—	135	—	180	—	187	—	1.5	1.5	455	776
140	—	198	—	174	—	174	—	4	1	803	1 630
150	—	210	—	240	—	240	—	1.5	0.5	993	2 270
170	—	240	—	175	—	175	—	2.5	1.5	980	1 990
	—	250	—	230	—	230	—	2.5	1.5	1 370	2 860
190.500	7.5000	266.700	10.5000	188.913	7.4375	187.325	7.3750	3.2	1	1 060	2 270
195	—	270	—	250	—	250	—	2.5	1	1 420	3 550
200	—	300	—	300	—	300	—	4	1.6	2 260	4 900
203.200	8.0000	317.500	12.5000	266.700	10.5000	266.700	10.5000	5	1.6	2 060	4 010
206.375	8.1250	282.575	11.1250	190.500	7.5000	190.500	7.5000	3.2	1	1 100	2 240
	8.1250	282.575	11.1250	240.000	9.4488	210.000	8.2677	3	1	1 450	3 380
215.900	8.5000	288.925	11.3750	177.800	7.0000	177.800	7.0000	3.2	1	1 060	2 350
220	—	295	—	315	—	315	—	SP	SP	1 540	3 910
	—	320	—	290	—	290	—	3	2	2 200	4 700
	—	330	—	260	—	260	—	5	2.5	2 100	4 220
220.663	8.6875	314.325	12.3750	239.713	9.4375	239.713	9.4375	3.2	3	1 680	3 410
	8.6875	314.325	12.3750	330.000	12.9921	330.000	12.9921	3.2	3	2 360	5 650
225	—	320	—	230	—	230	—	3	1.5	1 630	3 350
228.600	9.0000	311.150	12.2500	200.025	7.8750	200.025	7.8750	3.2	SP	1 330	2 850
234.950	9.2500	327.025	12.8750	196.850	7.7500	196.850	7.7500	3.2	1	1 490	3 310

[Note] 1) SP indicates the specially chamfered form.

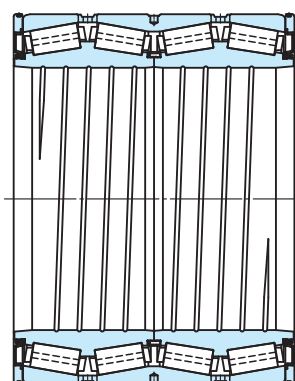

Design 2-P

Bearing No.	Design	Con- stant <i>e</i>	Axial load factors		(Refer.) Mass (kg)
			Y_2	Y_3	
47TS151215	1	0.33	2.03	3.02	6.4
47TS151418	1	0.87	0.78	1.16	10.7
47TS282017	1	0.47	1.43	2.12	16.3
47TS302124	1	0.39	1.74	2.59	23.5
47TS342418	1	0.26	2.55	3.8	23.9
47TS342523	1	0.26	2.55	3.8	37.7
47TS382719A	1	0.46	1.47	2.19	27.6
47TS392725-1	1	0.4	1.68	2.5	43.6
47TS403030	1	0.26	2.55	3.8	73.5
47TS413227	1	0.4	1.68	2.5	76.8
47TS412819	1	0.51	1.33	1.97	33.5
47TS412824	1	0.43	1.57	2.34	39.6
47TS432918	1	0.4	1.68	2.5	30.6
47TS443032A	1	0.4	1.68	2.5	55.8
47TS443229B	1	0.39	1.74	2.59	73.9
47TS443326	1	0.4	1.68	2.5	79.5
47TS443124	1	0.33	2.03	3.02	51.9
47TS443133	1	0.26	2.55	3.8	79.2
47TS453223A	1	0.47	1.43	2.12	56.9
47TS463120-1	1	0.4	1.68	2.5	41.3
47TS473320A	2	0.4	1.68	2.5	48.1

Sealed type four-row tapered roller bearings

d 240 ~ (280) mm

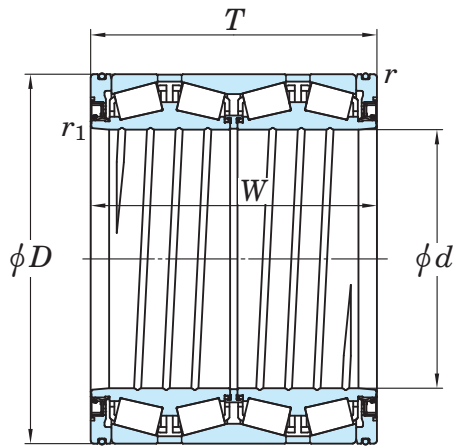

Design 1

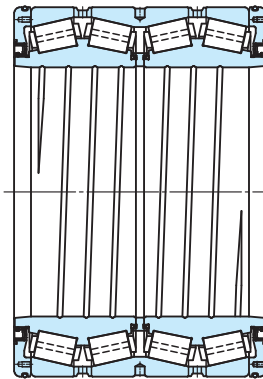

Design 1-P

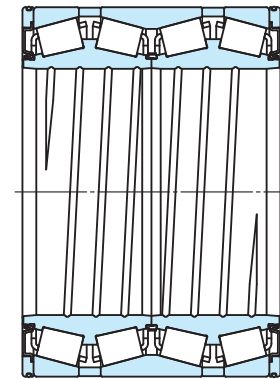

Design 2

Boundary dimensions										Basic load ratings (kN)	
d mm	1/25.4	D		T		W		r min.	$r_1^{1)}$ min.	C_r	C_{0r}
		mm	1/25.4	mm	1/25.4	mm	1/25.4				
240	—	320	—	294	—	294	—	4	1	1 880	4 760
	—	338	—	248	—	248	—	3	1.5	1 890	4 120
	—	338	—	290	—	290	—	3	1	2 360	5 360
	—	338	—	320	—	320	—	3	1	2 430	5 890
	—	338	—	340	—	340	—	3	1	2 450	5 930
241.478	9.5070	349.148	13.7460	228.600	9.0000	228.600	9.0000	3.2	SP	2 000	4 110
244.475	9.6250	327.025	12.8750	193.675	7.6250	193.675	7.6250	5	1.5	1 280	2 790
	9.6250	381.000	15.0000	304.800	12.0000	304.800	12.0000	5	1.6	2 700	5 240
245	—	345	—	310	—	310	—	3	1.5	2 520	6 020
250	—	365	—	270	—	270	—	3	1.5	2 260	4 730
254.000	10.0000	358.775	14.1250	269.875	10.6250	269.875	10.6250	3.2	1.6	2 130	4 760
	10.0000	358.775	14.1250	269.875	10.6250	269.875	10.6250	3.2	1.5	2 520	6 010
260	—	365	—	340	—	340	—	3.5	1.6	2 800	6 530
	—	370	—	354	—	354	—	4	1.5	3 100	7 410
266.700	10.5000	355.600	14.0000	228.600	9.0000	230.188	9.0625	3.2	1.6	1 940	4 880
275	—	385	—	340	—	340	—	3	1.5	2 970	7 400
276.225	10.8750	393.700	15.5000	269.875	10.6250	269.875	10.6250	3.2	1.6	2 350	5 040
	10.8750	393.700	15.5000	269.875	10.6250	269.875	10.6250	3.2	SP	2 770	6 510
279.400	11.0000	393.700	15.5000	269.875	10.6250	269.875	10.6250	3.2	1.6	2 350	5 040
	11.0000	393.700	15.5000	269.875	10.6250	269.875	10.6250	3.2	SP	2 770	6 510
	11.0000	393.700	15.5000	320.000	12.5984	320.000	12.5984	3.2	1.5	2 880	6 900
279.578	11.0070	380.898	14.9960	244.475	9.6250	244.475	9.6250	3.2	SP	2 270	5 360
280	—	380	—	290	—	290	—	3.2	SP	2 720	6 940

[Note] 1) SP indicates the specially chamfered form.

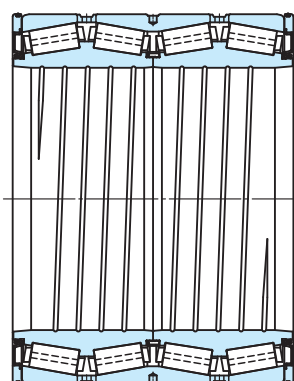

Design 2-P

Bearing No.	Design	Constant e	Axial load factors		(Refer.) Mass (kg)
			Y_2	Y_3	
47TS483229-1	1	0.33	2.03	3.02	63.6
47TS483425B	1	0.47	1.43	2.12	66
47TS483429	1	0.39	1.74	2.59	78
47TS483432	1	0.28	2.43	3.61	87.3
47TS483434A	1	0.4	1.68	2.5	88
47TS483523A	2	0.35	1.91	2.84	67.5
47TS493319	1	0.33	2.03	3.02	41.5
47TS493830	1	0.47	1.43	2.12	124
47TS493531-2	1	0.4	1.68	2.5	89.9
47TS503727A-1	1	0.4	1.68	2.5	94.2
47TS513627A-1	1	0.55	1.24	1.84	82
47TS513627B	2	0.4	1.68	2.5	85
47TS523734-5	1	0.4	1.68	2.5	110
47TS523735	1	0.26	2.55	3.8	120
47TS533623B	2	0.36	1.87	2.79	60
47TS553934	1	0.4	1.68	2.5	121
47TS553927-4	1	0.47	1.43	2.12	100
47TS553927A	2	0.4	1.68	2.5	105
47TS563927	1	0.47	1.43	2.12	99.5
47TS563927B	2	0.4	1.68	2.5	101
47TS563932-2	1	0.4	1.68	2.5	124
47TS563824	2	0.4	1.68	2.5	78.3
47TS563829A	2	0.33	2.03	3.02	93.8

Sealed type four-row tapered roller bearings

d (280) ~ 317.500 mm

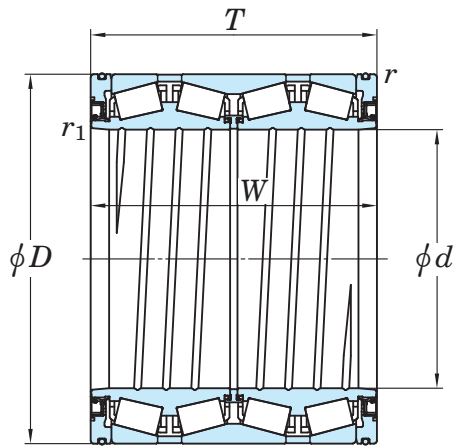

Design 1

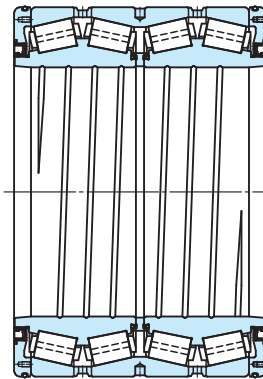

Design 1-P

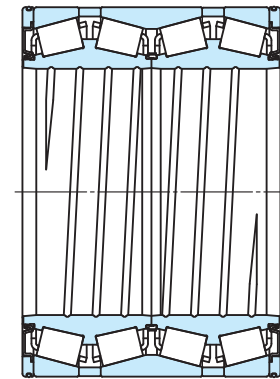

Design 2

Boundary dimensions										Basic load ratings (kN)	
d		D		T		W		r	$r_1^{1)}$	C_r	C_{0r}
mm	1/25.4	mm	1/25.4	mm	1/25.4	mm	1/25.4	min.	min.		
280	—	395	—	290	—	290	—	3	2.5	2 640	5 940
	—	395	—	340	—	340	—	3	1.5	2 960	7 110
	—	410	—	268	—	268	—	5.4	1.6	2 240	4 510
	—	412	—	340	—	340	—	4	2	3 350	7 220
	—	430	—	350	—	350	—	3.5	1.5	3 940	8 190
285	—	400	—	340	—	340	—	3	1.5	3 190	7 610
285.750	11.2500	380.898	14.9960	244.475	9.6250	244.475	9.6250	3.2	1	2 000	4 600
290	—	400	—	346	—	346	—	4	1.5	3 070	7 860
	—	400	—	420	—	420	—	4	1.5	3 070	7 860
	—	420	—	380	—	380	—	3	1.2	3 640	8 260
	—	450	—	415	—	415	—	4	1.5	4 460	9 460
300	—	400	—	254	—	254	—	4	5	2 220	5 300
	—	420	—	310	—	310	—	4	3.5	2 890	6 670
304.648	11.9940	438.048	17.2460	279.400	11.0000	280.990	11.0626	4	1.6	2 570	5 380
	11.9940	438.048	17.2460	279.400	11.0000	279.400	11.0000	3.2	1.6	3 140	6 860
304.800	12.0000	419.100	16.5000	269.875	10.6250	269.875	10.6250	6.4	2	2 490	5 420
	12.0000	501.650	19.7500	336.550	13.2500	296.550	11.6752	4	4	4 280	8 570
304.902	12.0040	412.648	16.2460	266.700	10.5000	266.700	10.5000	3.2	0.8	2 750	6 820
310	—	430	—	310	—	310	—	3	1	3 010	6 880
	—	430	—	350	—	350	—	3.5	1.5	3 280	7 870
	—	430	—	350	—	350	—	3.5	SP	3 280	7 870
	—	457.098	—	390	—	390	—	4	1.5	4 200	9 500
317.500	12.5000	447.675	17.6250	367.000	14.4488	367.000	14.4488	4	1.6	3 680	8 500

[Note] 1) SP indicates the specially chamfered form.

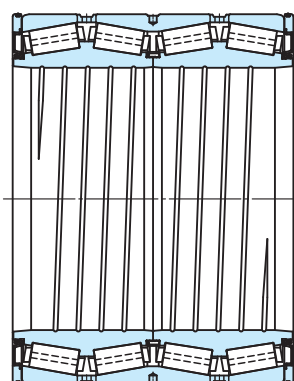

Design 2-P

Bearing No.	Design	Con- stant <i>e</i>	Axial load factors		(Refer.) Mass (kg)
			Y_2	Y_3	
47TS564029	1	0.4	1.68	2.5	110
47TS564034A	1	0.4	1.68	2.5	130
47TS564127	1	0.33	2.03	3.02	118
47TS564134	1	0.28	2.43	3.61	154
47TS564335	1	0.4	1.68	2.5	178
47TS574034	1	0.4	1.68	2.5	131
47TS573824A	1	0.43	1.57	2.34	73.2
47TS584035	1	0.4	1.68	2.5	128
47TS584042C	1	0.4	1.68	2.5	155
47TS584238	1	0.4	1.68	2.5	175
47TS584542	1	0.47	1.43	2.12	238
47TS604025	1	0.28	2.43	3.61	84.6
47TS604231	1	0.4	1.68	2.5	128
47TS614428B-10	1	0.47	1.44	2.15	135
47TS614428C-1	2	0.4	1.68	2.5	135
47TS614227	1	0.33	2.03	3.02	100
47TS615034	1-P	0.33	2.03	3.02	257
47TS614127D	2	0.39	1.74	2.59	99.5
47TS624331-4	1	0.4	1.68	2.5	131
47TS624335A	1	0.4	1.68	2.5	148
47TS624335B-2	1	0.4	1.68	2.5	148
47TS624639	1	0.32	2.12	3.15	220
47TS644537-1	1	0.4	1.68	2.5	176

Sealed type four-row tapered roller bearings

d 320 ~ 410 mm

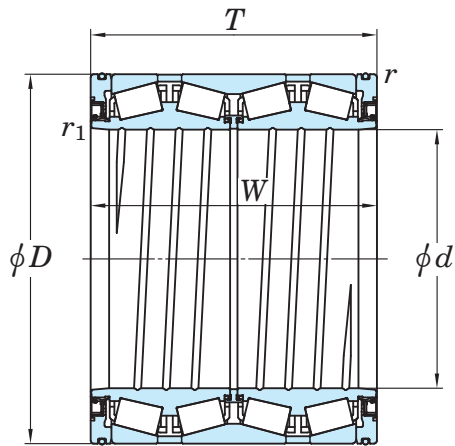

Design 1

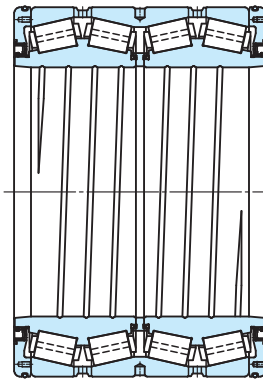

Design 1-P

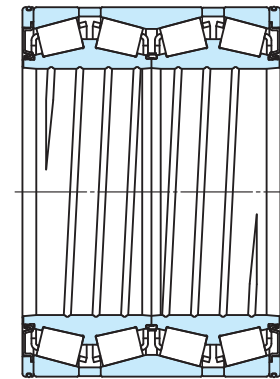

Design 2

Boundary dimensions										Basic load ratings (kN)	
d		D		T		W		$r^{1)}$	$r_1^{1)}$	C_r	C_{0r}
mm	1/25.4	mm	1/25.4	mm	1/25.4	mm	1/25.4	min.	min.		
320	—	440	—	335	—	335	—	4	1	3 140	7 330
	—	480	—	360	—	360	—	4	1.5	4 210	8 800
	—	480	—	420	—	420	—	4	1.5	5 470	12 100
330.302	13.0040	438.023	17.2450	254.000	10.0000	247.650	9.7500	3.2	1.6	2 190	4 960
335.000	13.1890	460.000	18.1102	342.900	13.5000	342.900	13.5000	3.3	1.5	3 740	9 290
342.875	13.4990	488.900	19.2480	410.000	16.1417	410.000	16.1417	4	2	4 620	11 600
342.875	—	560	—	500	—	500	—	5	2.5	7 210	15 000
343.052	13.5060	457.098	17.9960	254.000	10.0000	254.000	10.0000	3.2	0.8	2 870	7 030
	13.5060	457.098	17.9960	299.000	11.7717	299.000	11.7717	3.2	SP	3 310	9 010
346.075	13.6250	488.950	19.2500	358.775	14.1250	358.775	14.1250	4	2	3 780	8 310
350	—	480	—	420	—	420	—	SP	1.5	3 700	9 100
355	—	490	—	316	—	316	—	2	1.6	3 540	7 920
355.600	14.0000	482.600	19.0000	269.875	10.6250	265.112	10.4375	3.2	1.5	2 680	6 090
360	—	480	—	375	—	375	—	3	1	4 120	10 600
374.650	14.7500	501.650	19.7500	260.350	10.2500	250.825	9.8750	3.2	1.6	3 120	7 470
380	—	580	—	370	—	370	—	3	SP	5 690	12 300
395	—	545	—	360	—	360	—	6	1.6	3 790	8 930
406.400	16.0000	546.100	21.5000	288.925	11.3750	288.925	11.3750	6.4	1	3 620	8 190
	16.0000	546.100	21.5000	330.000	12.9921	330.000	12.9921	4	1.5	4 310	10 500
	16.0000	546.100	21.5000	357.400	14.0709	357.400	14.0709	3.2	1.6	3 960	9 540
410	—	546	—	400	—	400	—	4	1.5	4 630	12 000

[Note] 1) SP indicates the specially chamfered form.

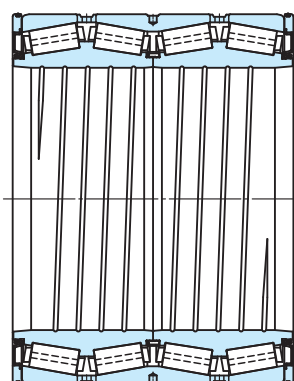

Design 2-P

Bearing No.	Design	Con- stant <i>e</i>	Axial load factors		(Refer.) Mass (kg)
			Y_2	Y_3	
47TS644434	1	0.4	1.68	2.5	146
47TS644836B	1-P	0.47	1.43	2.12	220
47TS644842	1-P	0.26	2.55	3.8	262
47TS664425	1	0.46	1.47	2.19	95.8
47TS674634A	1	0.4	1.68	2.5	167
47TS684941	1	0.33	2.02	3	233
47TS685650	1-P	0.33	2.03	3.02	495
47TS694625D-1	2	0.4	1.68	2.5	110
47TS694630B	2	0.4	1.68	2.5	135
47TS694936	1	0.33	2.03	3.02	210
45DS704842C	1-P	0.4	1.68	2.5	217
47TS714932	1	0.33	2.03	3.02	169
47TS714827	1-P	0.47	1.43	2.12	134
47TS724838A	1	0.4	1.68	2.5	181
47TS755026A	2	0.33	2.03	3.02	136
47TS765837	1-P	0.33	2.03	3.02	353
47TS795536A	1	0.47	1.43	2.12	242
47TS815529D-2	2-P	0.47	1.43	2.12	195
47TS815533A	2-P	0.43	1.57	2.34	204
47TS815536A	1	0.47	1.43	2.12	220
47TS825540	1	0.26	2.55	3.8	255

Sealed type four-row tapered roller bearings

d 415.925 ~ 482.600 mm

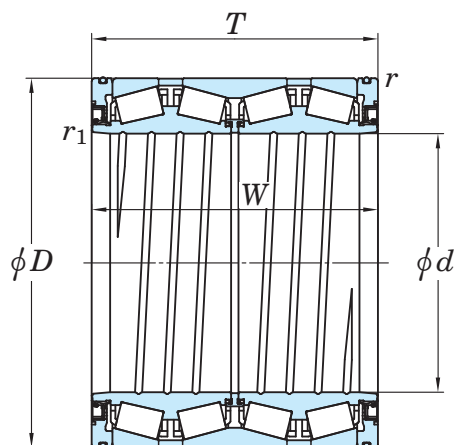

Design 1

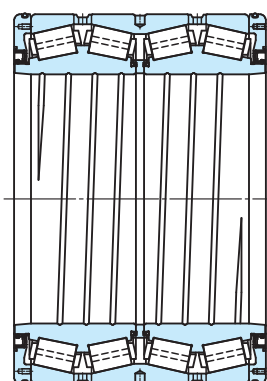

Design 1-P

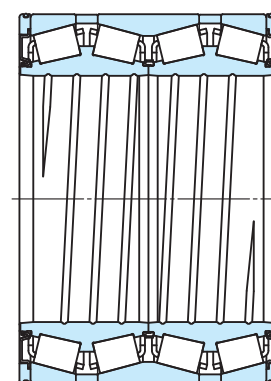

Design 2

Boundary dimensions										Basic load ratings (kN)	
d		D		T		W		$r^{1)}$	$r_1^{1)}$	C_r	C_{0r}
mm	1/25.4	mm	1/25.4	mm	1/25.4	mm	1/25.4	min.	min.		
415.925	16.3750	590.550	23.2500	434.975	17.1250	434.975	17.1250	4	1.5	6 390	15 600
420	—	560	—	437	—	437	—	4	3	5 620	14 900
	—	574	—	480	—	480	—	3	1.6	6 730	17 800
	—	620	—	395	—	320	—	SP	SP	5 160	11 600
430	—	575	—	380	—	380	—	3.2	SP	5 200	14 300
431.800	17.0000	571.500	22.5000	336.550	13.2500	336.550	13.2500	3.2	1.5	4 440	11 600
440	—	590	—	480	—	480	—	4	SP	6 870	18 700
	—	620	—	454	—	454	—	4	1.5	6 580	16 100
	—	635	—	470	—	413	—	5	2	6 870	15 700
450	—	595	—	420	—	420	—	5	1.5	6 110	16 300
457.200	18.0000	596.900	23.5000	279.400	11.0000	276.225	10.8750	3.2	1.6	3 760	9 520
	18.0000	596.900	23.5000	279.400	11.0000	276.225	10.8750	3.2	1.6	3 300	8 180
460	—	620	—	470	—	470	—	4	1.5	7 060	19 300
479.425	18.8750	679.450	26.7500	495.300	19.5000	495.300	19.5000	6.4	2	8 030	19 600
480.000	18.8976	647.700	25.5000	417.512	16.4375	417.512	16.4375	6.4	SP	6 680	17 400
480	—	700	—	470	—	470	—	5	1.5	8 080	18 800
482.600	19.0000	615.950	24.2500	330.200	13.0000	330.200	13.0000	6.4	1.6	4 310	11 700
	19.0000	615.950	24.2500	330.200	13.0000	330.200	13.0000	3.2	1.6	4 360	11 800
	19.0000	615.950	24.2500	330.200	13.0000	330.200	13.0000	3.2	1.6	4 510	12 400
	19.0000	615.950	24.2500	385.000	15.1575	385.000	15.1575	6.4	1.6	5 270	15 000
	19.0000	615.950	24.2500	420.000	16.5354	420.000	16.5354	6.4	1.6	5 090	14 500
	19.0000	615.950	24.2500	425.000	16.7323	425.000	16.7323	6.4	1.6	5 090	14 500
	19.0000	647.700	25.5000	417.512	16.4375	417.512	16.4375	6.4	1.6	6 680	17 400

[Note] 1) SP indicates the specially chamfered form.

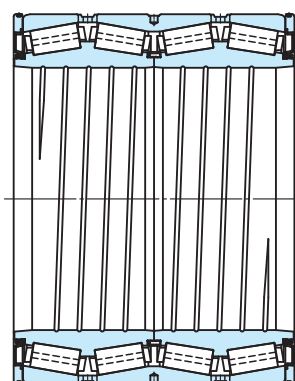

Design 2-P

Bearing No.	Design	Constant <i>e</i>	Axial load factors		(Refer.) Mass (kg)
			Y_2	Y_3	
47TS835944A	2-P	0.4	1.68	2.5	377
47TS845644	1	0.26	2.55	3.8	298
47TS845748	1-P	0.28	2.43	3.61	352
47TS846240	1-P	0.47	1.43	2.12	390
47TS865838A	2-P	0.26	2.55	3.8	276
47TS865734A	2	0.4	1.68	2.5	229
47TS885948A-3	2-P	0.26	2.55	3.8	362
47TS886245-1	1-P	0.33	2.03	3.02	430
47TS886447	1	0.33	2.03	3.02	461
47TS906042	1-P	0.26	2.55	3.8	308
47TS916028C	2-P	0.47	1.43	2.12	191
47TS916028D	2-P	0.7	0.97	1.44	187
47TS926247	1-P	0.26	2.55	3.8	412
47TS966850	1-P	0.33	2.03	3.02	562
47TS966542	1-P	0.33	2.03	3.02	391
47TS967047	1-P	0.32	2.12	3.15	621
4TRS19B	1-P	0.44	1.54	2.3	240
4TRS19C	2	0.4	1.68	2.5	229
4TRS19D	2-P	0.4	1.68	2.5	239
47TS976239	1-P	0.33	2.03	3.02	278
47TS976242	1	0.33	2.03	3.02	302
47TS976243	1	0.33	2.03	3.02	306
47TS976542A	1-P	0.33	2.03	3.02	382

Sealed type four-row tapered roller bearings

d 488.950 ~ 800 mm

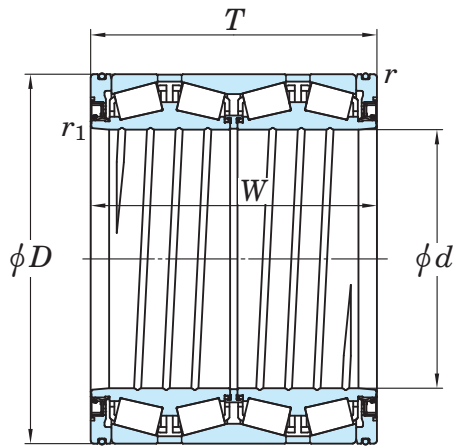

Design 1

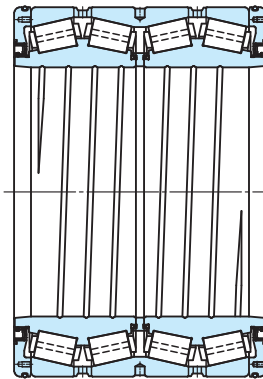

Design 1-P

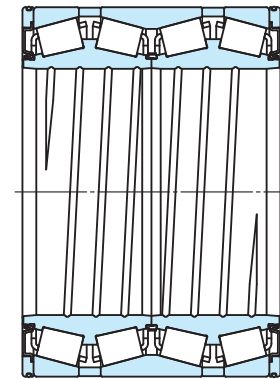

Design 2

Boundary dimensions										Basic load ratings (kN)	
d		D		T		W		r	$r_1^{1)}$	C_r	C_{0r}
mm	1/25.4	mm	1/25.4	mm	1/25.4	mm	1/25.4	min.	min.		
488.950	19.2500	622.300	24.5000	365.125	14.3750	365.125	14.3750	6.4	1.5	4 320	12 200
492	—	655	—	480	—	480	—	5	1.5	7 450	21 200
509.948	20.0767	654.924	25.7844	379.000	14.9213	377.000	14.8425	6.4	1.5	5 370	15 200
530	—	715	—	590	—	590	—	5	1.5	10 300	28 900
558.800	22.0000	736.600	29.0000	372.263	14.6560	372.263	14.6560	7	SP	6 910	16 100
	22.0000	736.600	29.0000	409.575	16.1250	409.575	16.1250	6	1.5	6 850	18 600
	22.0000	736.600	29.0000	450.000	17.7165	450.000	17.7165	6	1.5	7 180	19 700
	22.0000	736.600	29.0000	480.000	18.8976	480.000	18.8976	6	1.5	7 960	22 700
	22.0000	736.600	29.0000	500.000	19.6850	500.000	19.6850	6	1.6	8 220	23 100
585.788	23.0625	771.525	30.3750	479.425	18.8750	479.425	18.8750	6.4	1.5	8 730	24 400
595.312	23.4375	844.550	33.2500	615.950	24.2500	615.950	24.2500	6.4	3.6	12 700	32 200
600	—	870	—	700	—	700	—	5	4	15 100	39 400
609.600	24.0000	787.400	31.0000	361.950	14.2500	361.950	14.2500	6.4	3.2	5 920	14 900
	24.0000	813.562	32.0300	540.000	21.2598	540.000	21.2598	6.4	1.5	10 200	28 500
679.450	26.7500	901.700	35.5000	552.450	21.7500	552.450	21.7500	6.4	3	11 100	30 600
685.800	27.0000	876.300	34.5000	355.600	14.0000	352.425	13.8750	6.4	3.2	6 130	16 300
704.850	27.7500	914.400	36.0000	552.450	21.7500	552.450	21.7500	6.4	3.2	11 300	33 400
711.200	28.0000	914.400	36.0000	317.500	12.5000	317.500	12.5000	3.2	SP	6 070	16 700
	28.0000	914.400	36.0000	387.350	15.2500	387.350	15.2500	6.4	3.2	7 160	19 400
	28.0000	914.400	36.0000	410.000	16.1417	410.000	16.1417	6.4	3.2	7 610	20 500
	28.0000	914.400	36.0000	420.000	16.5354	420.000	16.5354	6.4	3.2	7 870	22 200
800	—	1 130	—	780	—	780	—	6	1.5	21 900	58 800

[Note] 1) SP indicates the specially chamfered form.

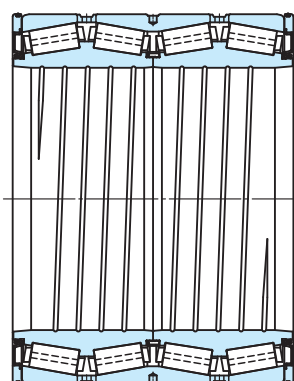

Design 2-P

Bearing No.	Design	Constant e	Axial load factors		(Refer.) Mass (kg)
			Y_2	Y_3	
47TS986236	1	0.4	1.68	2.5	270
47TS986648	1-P	0.33	2.03	3.02	449
4TRS510B	1-P	0.41	1.64	2.44	320
4TRS530A	1-P	0.26	2.55	3.8	664
4TRS559J	1-P	0.34	1.97	2.93	425
4TRS559C	1-P	0.35	1.95	2.9	475
4TRS559A	1-P	0.35	1.95	2.9	507
4TRS559B	1-P	0.4	1.68	2.5	547
4TRS559	1-P	0.35	1.95	2.9	560
4TRS586A	1-P	0.33	2.03	3.02	613
4TRS595B	1-P	0.33	2.03	3.02	1 120
4TRS600A	1-P	0.33	2.03	3.02	1 370
4TRS610	1-P	0.4	1.68	2.5	430
4TRS610A	1-P	0.33	2.03	3.02	775
4TRS679	1-P	0.33	2.03	3.02	951
4TRS686A	1-P	0.42	1.62	2.42	520
4TRS705	1-P	0.33	2.03	3.02	940
4TRS711N	2-P	0.46	1.47	2.19	507
4TRS711A	1-P	0.38	1.78	2.65	615
4TRS711	1-P	0.44	1.54	2.29	670
4TRS711L	1-P	0.4	1.68	2.5	678
4TRS800	1-P	0.26	2.55	3.8	2 520

KOYO

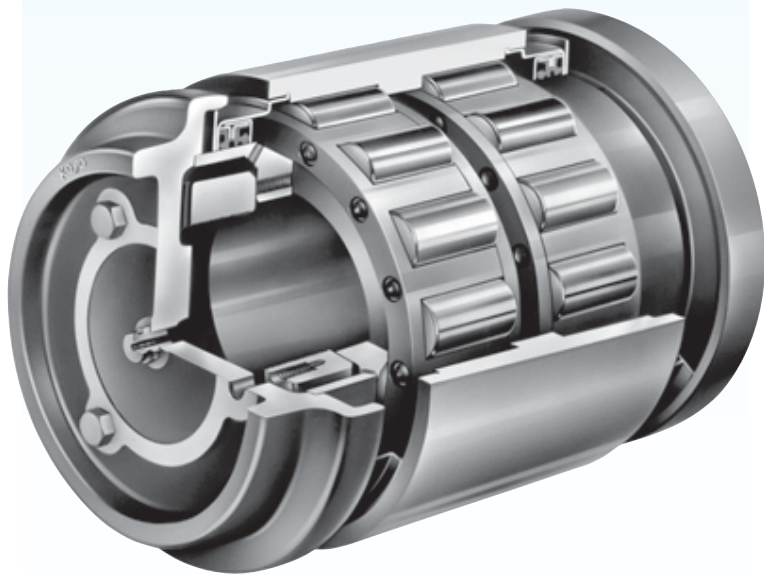

Bearings for railway rolling stock axle journals

Bearings used to support rolling stock axle journals are required to be very strong and, at the same time, to be small because of limited space.

Double-row bearings that are larger in width than general bearings are popular in that they are compact and have high load ratings.

■ Cylindrical roller bearings

- Feature good high-speed performance, and can be maintained and inspected easily because of their separable structure.
Most commonly used bearing.
- Those with a rib next to the inner ring are able to support not only radial load but also a certain degree of axial load, so that a ball bearing is not required to accommodate the axial load.

■ Sealed type cylindrical roller bearing units and tapered roller bearing units

- Maintenance-free : pre-lubricated with grease and provided with oil seals.
- Can be used with a simplified axle box, or with an adapter instead.
- The inch series axle bearing units (ABU) are as specified in the "association of american rail-roads".

Cylindrical roller bearings

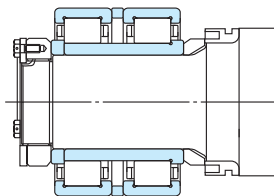

Bore diameter **85 – 133 mm**

Sealed type cylindrical roller bearing units

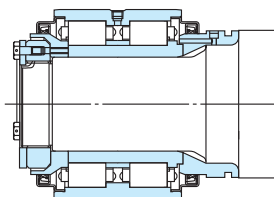

Bore diameter **95 – 120 mm**

Sealed type tapered roller bearing units(ABU)

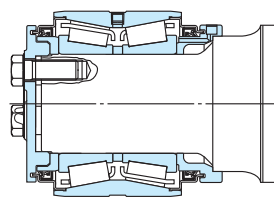

Bore diameter **101.600 – 177.787 mm**

Tolerances	<ul style="list-style-type: none"> ● Cylindrical roller and axial load support ball bearings : as specified in JIS B 1514-1, class 0 (Table 7-3 on pp. A 54–A 57). { The tolerances for cylindrical roller bearing width and overall width are as shown in Table 1. } ● Metric series ABU bearings: refer to Table 2. ● Inch series ABU bearings : refer to Table 3.
Recommended fits	Refer to Table 4.
Radial internal clearance	<ul style="list-style-type: none"> ● Cylindrical roller bearings : class C 3 UIC* standard cylindrical roller bearings : class C 4 (refer to Table 10-8 on p. A 100.) ● Axial load support ball bearings : class C 5 However, the clearance class should be adjusted according to the axle box structure. Consult with JTEKT for further information. ● ABU bearings : class C 3 (refer to Table 10-10 on p. A 104) *Denotes that the bearings are compatible with axle journals and axle boxes standardized by the UIC.

Table 1 Cylindrical roller bearings for axle journals : tolerances for inner ring width, outer ring width and overall width

(1) Tolerances for inner ring width and inner ring overall width Unit : μm

Bearing type	Design	Nominal bore diameter d (mm)		Δ_{B_s} or $\Delta_{B_{1s}}$	
		over	up to	upper	lower
Inner ring one-piece type, Inner ring with a rib and loose rib	1-1, 1-2	80	120	0	- 400
	2-1, 2-3	120	180	0	- 500
Two inner rings and spacer	2-2	80	120	0	- 600
		120	180	0	- 700

(2) Tolerances for outer ring width and outer ring overall width Unit : μm

Bearing type	Design	Nominal bore diameter d (mm)		Δ_{C_s} or $\Delta_{C_{1s}}$	
		over	up to	upper	lower
Outer ring one-piece type	2-3	80	120	0	- 300
		120	180	0	- 350
Outer ring and two loose ribs	1-1	80	120	+ 100	- 200
		120	180	+ 100	- 250
Two outer rings	2-1 ¹⁾	120	180	0	- 500
Two outer rings and spacer	1-2 2-1, 2-2	80	120	0	- 500
		120	180	0	- 600

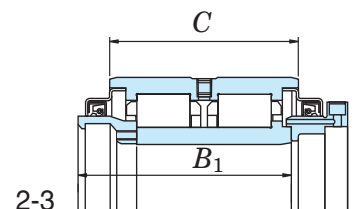
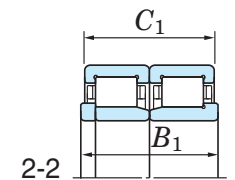
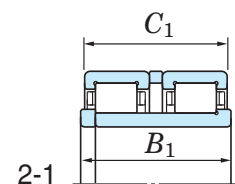
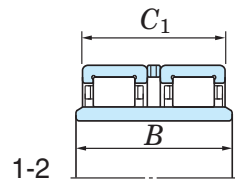
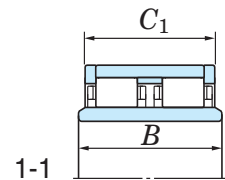

[Note] 1) (2-1) means that spacer shown in Design 2-1 is removed.

Table 2 Metric series ABU bearing tolerances Unit : μm

Nominal bore diameter d (mm)	Single plane mean bore diameter deviation Δ_{dmp}		Single plane mean outside diameter deviation Δ_{Dmp}		Single outer ring width deviation Δ_{Cs}		Actual overall width of inner rings deviation Δ_{B1s}	
	upper	lower	upper	lower	upper	lower	upper	lower
110	0	-20			+ 50	- 50		
120	0	-20	0	-125	+ 100	- 100	+ 500	- 500
130	0	-25			+ 100	- 100		

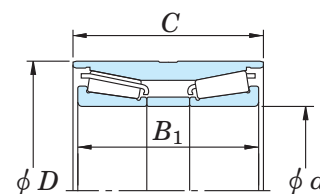
Table 3 Inch series ABU bearing tolerances Unit : μm

Nominal bore diameter d (mm)	Single plane mean bore diameter deviation Δ_{dmp}		Single plane mean outside diameter deviation Δ_{Dmp}		Single outer ring width deviation Δ_{Cs}		Actual overall width of inner rings deviation Δ_{B1s}	
	upper	lower	upper	lower	upper	lower	upper	lower
101.6to177.8	+ 25	0	+ 127	0	+ 50	- 250	+ 710	- 510

Table 4 Axle journal bearing recommended fits

Bearing type	Axle journal diameter (mm)		Axle journal tolerance class	Axle box bore tolerance class
	over	up to		
Cylindrical roller bearing Tapered roller bearing	50	100	(m 6), n 6	H 7
	100	140	n 6	
	140	240	p 6	
Axial load support deep groove ball bearing	All diameters		k 5	Clearance fit (clearance of approx. 0.2 to 0.6 mm)

Cylindrical roller bearings for railway rolling stock axle journals

d 85 ~ (120) mm

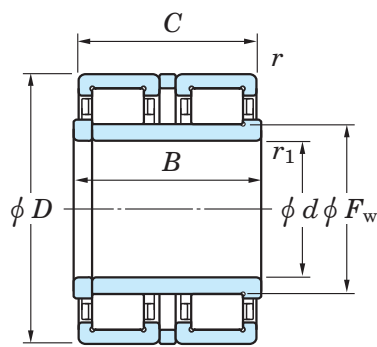

Design 1

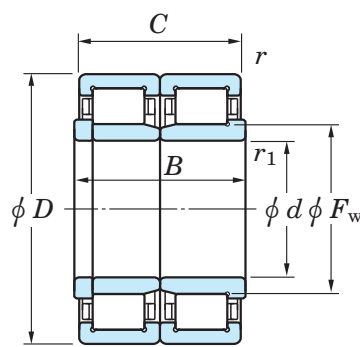

Design 2

Boundary dimensions (mm)							Basic load ratings (kN)		Bearing No. ²⁾	Design ³⁾	(Refer.) Mass (kg)
d	D	B	C	F_w	$r_{\min.}$	$r_1^{1)}$ min.	C_r	C_{0r}			
85	150	130	120	101.5	1.1	(7)	369	592	2U2217SC	3	8.6
90	160	88	80	107	2	2	355	529	2CR90D	1	7.2
95	170	120	105	114	1.1	(10)	497	804	2UJ95	4	10.9
	170	125	115	113.5	2.5	(7)	441	687	2CR95A	1	11.5
	170	130	130	114	2	2	441	688	2UJ1917	3	11.4
	170	140	125	114	1.1	(10)	555	926	4UJ95	5	12.7
100	180	150	134	120	1.1	(10)	594	990	4UJ100	5	15.1
	190	140	130	122	2.5	(7)	697	1 120	20DC19130/140	3	16.9
	200	170	170	125	2	(7)	755	1 160	2CR100	1	23.7
	200	170	170	125	2	(10)	755	1 160	20DC20170	3	23.2
110	200	180	160	134	1.1	(7)	721	1 190	JC3	5	22.6
	220	180	160	138	2.5	(7)	789	1 190	JC6	1	30.0
	220	185	180	138	2	(7)	922	1 460	2CR110	1	31.3
	225	150	140	138	1.1	(7)	833	1 230	JC1A	4	27.7
	225	150	140	138	2.5	(7)	897	1 350	22DC23140/150	3	26.7
	235	180	160	141	2.5	(7)	934	1 430	JC2A	3	35.3
116	220	185	180	142	2	(7)	891	1 470	2CR116	1	30.5
	225	150	140	197.5	1.1	(7)	786	1 220	2UJ116	4	26.0
120	225	170	165	145	3	(10)	876	1 380	JC35	1	29.4
	230	170	165	145	3	(10)	943	1 460	JC34	1	30.8
	230	177	150	145	3	(30)	943	1 460	JC27X	(1)	29.7
	240	160	160	150	3	7.5	961	1 500	(24NJ/NJP2480)	2	33.9
	240	180	160	150	1.1	(10)	1 020	1 580	JC11	4	35.5
	240	180	176	150	3	(7)	1 020	1 580	JC12	1	37.7

- [Notes] 1) Values in () indicate axial chamfer dimension.
 2) Bearings indicated in () are in accordance with UIC standards.
 3) (1) means that the inner ring (rib side) shown in Design 1 has a special form.
 (2) means that loose rib shown in Design 2 is replaced with thrust collar.

d (120) ~ 133 mm

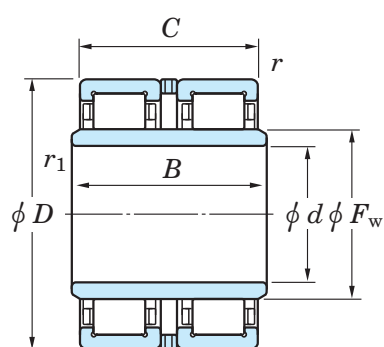

Design 3

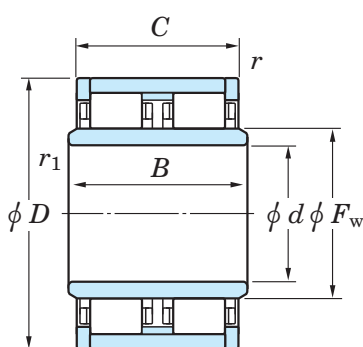

Design 4

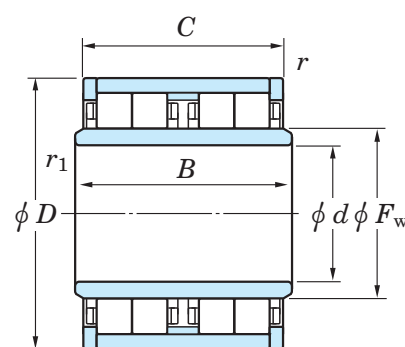

Design 5

d	Boundary dimensions (mm)						Basic load ratings (kN)		Bearing No. ²⁾	Design ³⁾	(Refer.) Mass (kg)
	D	B	C	F_w	$r_{\min.}$	$r_1^{1)}$ $\min.$	C_r	C_{0r}			
120	240	185	180	150	2	(7)	983	1 600	2CR120A	1	37.8
130	220	170	160	152	1.1	0.6	865	1 520	4UJ130B	5	25.2
	240	160	160	157	3	5	867	1 390	(2CR2624A)	2	32.0
	240	180	160	158	1.1	(10)	970	1 610	4UJ130A	5	35.8
	240	204	198	157	3	5	867	1 390	(2CR2624)	2	35.4
	250	160	160	158	3	7.5	1 090	1 720	(26NJ/NJP2580)	2	36.4
	260	180	160	163	1.1	(10)	1 080	1 710	JC5	4	42.7
	260	185	180	163	3	(7)	1 030	1 610	2CR130A	1	44.2
	260	186	172	164	3	7.5	1 220	1 930	26NJ/NUJ2686	(2)	44.6
	260	205.5	180	163	3	(30)	1 030	1 610	JC21	(1)	45.1
	270	215	210	164	4	(15)	1 280	2 000	JC29	3	55.1
280	215	210	167	4	(15)	1 440	2 250	JC9-1	3	61.4	
133	280	215	210	167	4	(15)	1 440	2 250	JC9-2	3	59.8

Sealed type cylindrical roller bearings for railway rolling stock axle journals

d 95 ~ 120 mm

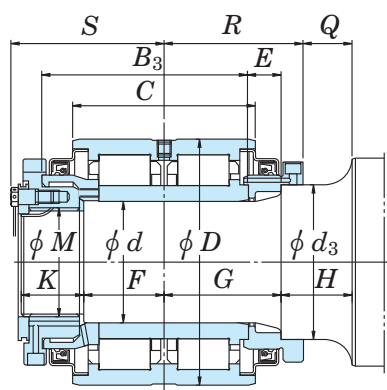

Design 1

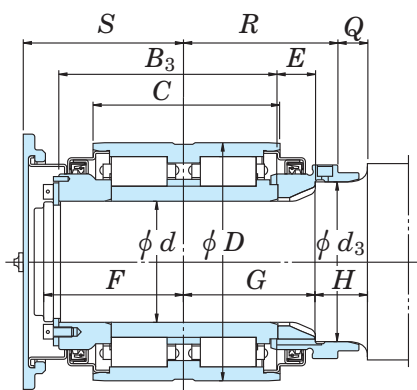

Design 2

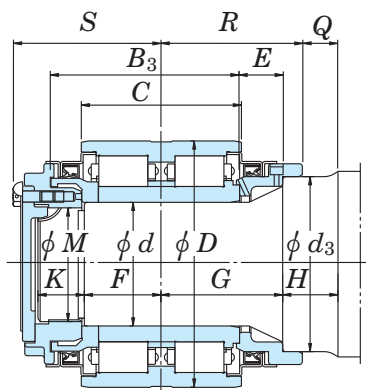

Design 3

Shaft dia. (mm) d	Unit No.	Design	Boundary dimensions (mm)											
			$d_{Brg.}$	D	C	B_3	d_3	E	F	G	H	K	L	M
95	JB1425	1	95	190	140	158	120	25	62	90	35	48	—	M85×4
100	JB1199B	2	100	195	150	175	130	30	120	105	42	—	—	—
110	JB1462	3	110	220	145	171	155	39	70	110	50	42	—	M100×2
120	JB1356	4	120	220	150	170	158	46	70	116	36	51	—	M115×4
	JB1380D	5	120	230	150	171	155	43	70	113	42	42	33	M110×2
	JB1010	6	120	240	170	218	168	35	87	125	45	43	—	M110×2
	JB1240	7	120	240	160	193	168	31	80	113	38	40	38	M110×2
	JB1377	8	120	240	160	192	150	30	83	112	40	38	—	M110×4

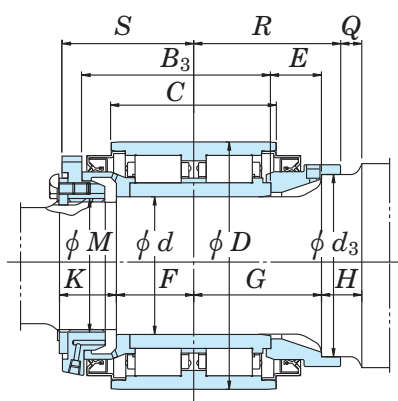

Design 4

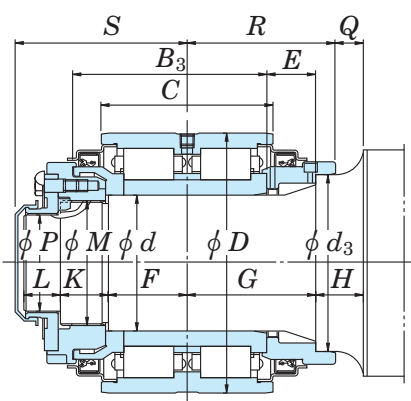

Design 5

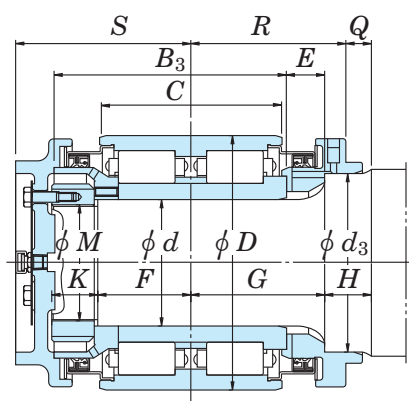

Design 6

<i>P</i>	<i>Q</i>	<i>R</i>	<i>S</i>	Bearing No.	Basic load ratings (kN)		(Refer.) Unit Mass (kg)
					C_r	C_{0r}	
—	18	107	119	19RDC19140/158	610	910	24.5
—	24	123	130	20RDC20150/133B	673	1 040	27.5
—	33	127	134	S-JC33	789	1 190	35.9
—	19	133	131	24RDC22150/170	702	1 110	34.9
85	25	130	152	JC32	831	1 290	39.0
—	25	145	164	JC17	1 020	1 580	57.7
85	27	128	169	JC26	935	1 420	51.1
—	—	135	131	24RDC24160/192A	935	1 420	42.0

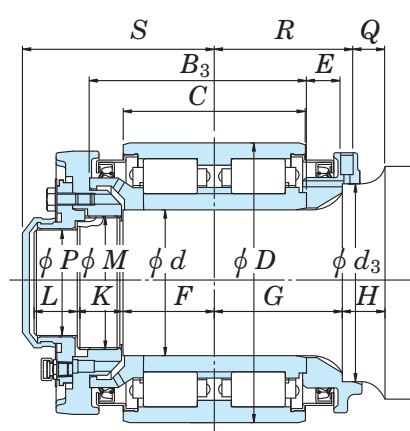

Design 7

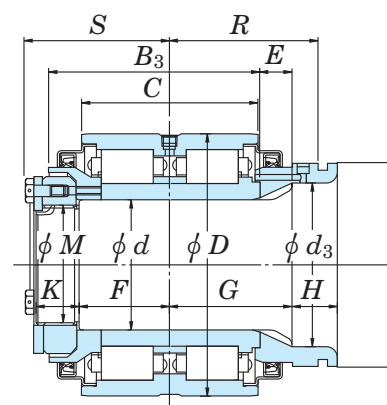

Design 8

Sealed type tapered roller bearings for railway rolling stock axle journals (ABU bearing)

d 101.6 ~ 177.787 mm
110 ~ 130 mm

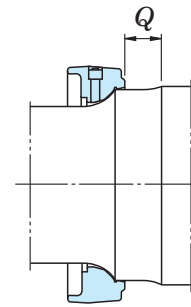
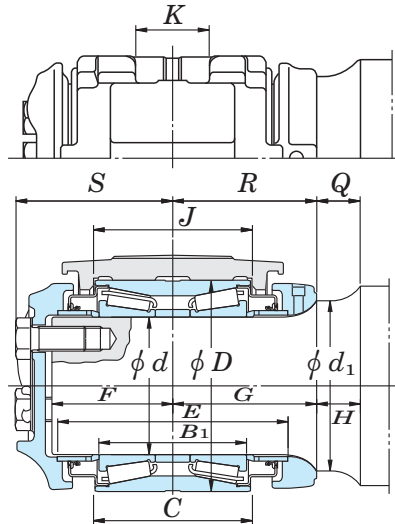
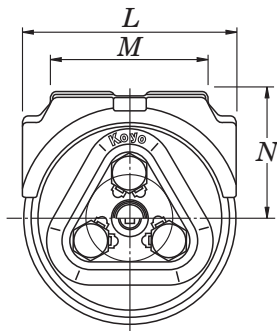

The shape of the backing ring used for JB1204P, JB1205P and JB1206P.

Class	Axle size	Unit No.	Boundary dimensions												
			(mm)												
			Brg.	d Axle ¹⁾	D	B_1	C	d_1 ¹⁾	E	F	G	H	Q	R	S
B	4 1/4x8	JB1201	101.600	101.702 101.676	165.100	106.362	114.300	127.0	182.6	101.6	117.5	41.3	41.3	117.5	134.8
C	5 x9	JB1202	119.062	119.164 119.139	195.262	136.525	142.875	149.2	217.5	112.7	134.9	36.5	36.5	134.9	147.0
D	5 1/2x10	JB1203	131.750	131.864 131.839	207.962	146.050	152.400	161.9	227.0	115.9	139.7	44.5	44.5	139.7	150.5
E	6 x11	JB1204	144.450	144.564 144.539	220.662	155.575	163.512	177.8	241.3	127.0	150.8	46.0	46.0	150.8	164.1
		JB1204P	144.450	144.564 144.539	220.662	155.575	163.512	178.613 178.562	241.3	127.0	150.8	46.0	36.8	160.0	164.1
F	6 1/2x12	JB1205	157.150	157.264 157.239	252.412	177.800	184.150	190.5	273.0	134.9	163.5	46.0	46.0	163.5	176.6
		JB1205P	157.150	157.264 157.239	252.412	177.800	184.150	191.313 191.262	273.0	134.9	163.5	46.0	36.7	172.8	176.6
G	7 x12	JB1206P	177.787	177.902 177.876	276.225	180.975	185.738	203.251 203.200	269.9	130.2	150.8	58.7	46.0	163.5	180.1

—	110	JB558	110	110.076 110.054	175	125	130	155	206	105	135	30	30	135	136.4
—		JB1486	110	110.059 110.037	205	130	140	150.068 150.043	—	85	105	53	43	115	118.4
—	120	JB613	120	120.076 120.054	195	136	142	155	217	113	135	30	30	135	147.5
—		JB1450	120	120.059 120.037	220	155	155	150.068 150.043	—	125	100	55	35	120	164.4
—	130	JB633	130	130.076 130.054	208	146	152	165	227	139	139	26	26	139	149.2

[Notes] 1) Upper figures : max. value ; lower : min.value

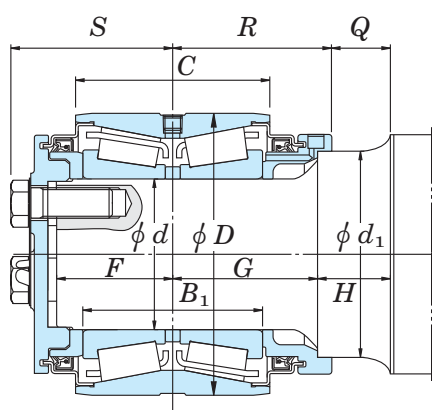

JB1486

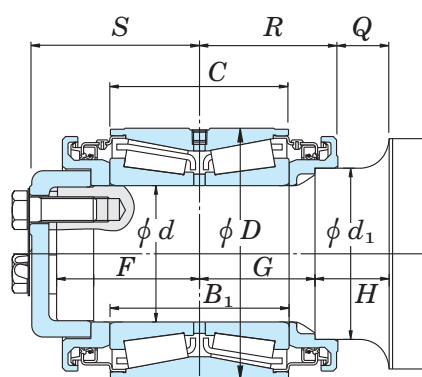

JB1450

Dynamic equivalent load
 (when $F_a/F_r \leq e$)
 $P = F_r + Y_2 F_a$
 (when $F_a/F_r > e$)
 $P = 0.67 F_r + Y_3 F_a$
 Static equivalent load
 $P_0 = F_r + Y_0 F_a$

Adapter No.	Dimensions of adapter (mm)					Bolt size	Dimensions (mm) <i>p</i>	Bearing No.	Basic load ratings (kN)		Constant <i>e</i>	Axial load factors			(Refer.) Mass (kg)	
	<i>J</i>	<i>K</i>	<i>L</i>	<i>M</i>	<i>N</i>				<i>C_r</i>	<i>C_{0r}</i>		<i>Y₂</i>	<i>Y₃</i>	<i>Y₀</i>	Unit	Adapter
JB701	117.5	68.3	165.9	124.6	101.6	3/4-10 UNC	61.9	HM120848/ HM120817XD	402	769	0.26	2.55	3.80	2.50	17.3	3.8
JB702	146.0	74.6	196.1	143.7	117.5	7/8-9 UNC	76.2	HM124646/ HM124618XD	626	1 200	0.26	2.55	3.80	2.50	25.3	6.1
JB703	155.6	74.6	208.8	156.4	123.8	7/8-9 UNC	88.9	HM127446/ HM127415XD	641	1 270	0.26	2.55	3.80	2.50	28.3	7.4
JB704	166.7	96.8	221.5	181.8	136.5	1-8 UNC	98.4	HM129848/ HM129814XD	667	1 380	0.26	2.55	3.80	2.50	34.3	10.8
JB704	166.7	96.8	221.5	181.8	136.5	1-8 UNC	98.4	HM129848/ HM129814XD	667	1 380	0.26	2.55	3.80	2.50	35.0	10.8
JB705	187.3	96.8	253.2	194.5	152.4	1 1/8-7 UNC	108.0	HM133444/ HM133416XD	910	1 890	0.26	2.55	3.80	2.50	51.6	16.3
JB705	187.3	96.8	253.2	194.5	152.4	1 1/8-7 UNC	108.0	HM133444/ HM133416XD	910	1 890	0.26	2.55	3.80	2.50	52.4	16.3
JB706 ²⁾	189.7	181.0	—	279.4	168.3	1 1/4-7 UNC	117.5	HM136948/ HM136916XD	1 080	2 220	0.26	2.55	3.80	2.50	59.2	23
JB558	134	70	175	135	110	M22	75	JT9	481	972	0.26	2.55	3.80	2.50	22.0	5.6
—	—	—	—	—	—	M22	75	JT13	743	1 220	0.26	2.55	3.80	2.50	27.3	—
JB613	146	74.5	196	142.5	118	M22	75	JT10	626	1 200	0.26	2.55	3.80	2.50	27.0	6.2
—	—	—	—	—	—	M22	75	JT12	907	1 670	0.26	2.55	3.80	2.50	36.6	—
JB633 ²⁾	156	110	255	232	130	M22	89	JT11	641	1 270	0.26	2.55	3.80	2.50	30.0	14.3

2) JB706 and JB633 indicate the specifications of wide adapters. Others indicate narrow adapters (shown in figures above).

KOYO





Linear ball bearings

Linear ball bearings have an outer cylinder and a cage with three or more elliptic raceways inside.

Balls are aligned on these raceways.

Ball complement
bore diameter (mm)

SDM series	6 – 120
SDMF, SDMk series	6 – 80
SDE series	5 – 80

Standard type	Clearance adjustable type	Open type
		
Suitable for a wide range of applications and widely used in practice. The upper-class type is used for general purposes. The precision-class type is used when the bearing is required to be highly accurate.	The outer cylinder and side plate are slit axially so that the clearance between the bearing and shaft can be adjusted. Together with the use of a boreadjustable housing, a no-clearance state or light-preloaded state can be realized without fitting.	The outer cylinder and side plate each have a slit which is equivalent in size to a recirculating ball row raceway, so that the bearing does not interfere with a shaft strut during operation. This type is suitable for use with very long shafts. The bore diameter is adjustable.

Flanged type



Can be fit quickly, and helps make equipment smaller and lighter in weight. Helps reduce cost.

Sealed type

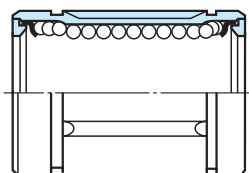

One or both side(s) is/are sealed with special synthetic rubber so that foreign material cannot enter the bearing while the grease is kept from leaking. This sealing can be provided on all bearings of the standard, clearance adjustable, open, and flanged types.

Bearing numbering system

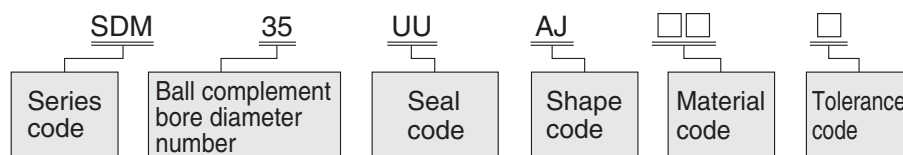

Series code		SDM : metric series SDMF : metric series (flanged type) SDMK : metric series (flanged type) SDE : metric series (popular ones in europe) SDB : inch series
Ball complement bore diameter number	Metric series	35 : ball complement bore diameter 35 mm
	Inch series	4 : ball complement bore diameter 4/16 = 1/4 inch
Seal code		UU : both sides sealed U : single side sealed Not specified : not sealed
Shape code		Not specified : standard type AJ : clearance adjustable type OP : open type
Material code	Outer cylinder and balls	Not specified : high carbon chrome bearing steel
	Cage	Not specified : cold rolled steel sheet MG : synthetic resin
Tolerance code		Not specified : upper-class P : precision-class

■ Linear ball bearing service life

Linear ball bearing service life refers to the distance that the bearing travels until the outer cylinder, balls or shaft become damaged because of rolling contact fatigue from repeated stress.

The basic dynamic load rating refers to the magnitude of a constant load which makes a bearing's service life end after it travels a distance of 50 km.

The linear ball bearing service life and the basic dynamic load rating bear the relation shown below :

$$L = 50 \left(\frac{C}{P} \right)^3$$

where :

L : service life km
 P : radial load on the bearing N
 C : bearing basic dynamic load rating N
 (refer to the specification table.)

Shaft surface hardness is closely related to running performance. In general, it is best for the hardness to be 60 thru 64 HRC.

If the hardness is 60 HRC or lower, the basic dynamic load rating (C) should be corrected by multiplying it by the appropriate hardness coefficient selected from Table 1.

Shaft hardness HRC	Hardness coefficient f_H
60	1
59	0.97
57	0.88
55	0.76
53	0.64
51	0.52

● Ball row arrangement and load rating

The basic load ratings given in the specification table are those measured when a load is applied directly above a ball row (Q_1). When the load is applied between two ball rows, the load ratings become larger (Q_2). Table 2 lists the ratios of Q_2 ratings to Q_1 ratings.

Table 2 Ball row arrangement and the comparison of load ratings

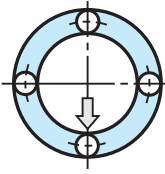
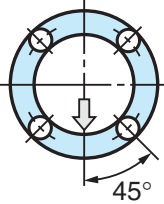
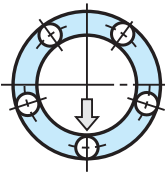
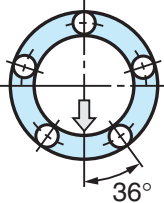
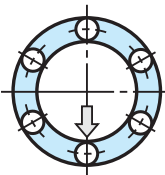
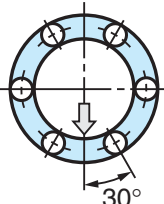
Number of ball rows	When a load is applied directly above a row (Q_1)	When a load is applied between two rows (Q_2)	Ratios of Q_2 to Q_1
4			1.414
5			1.463
6			1.280

[Note] When there are only three rows, $Q_2 / Q_1 = 1$

Table 4 SDM series linear ball bearing tolerances

Unit : μm

Bearing number SDM	Ball complement bore diameter (F_w) deviation				Outside diameter (D) deviation		Overall length (L) deviation		B deviation		Eccentricity	
	Precision-class		Upper-class		upper	lower	upper	lower	upper	lower	Precision-class	Upper-class
	upper	lower	upper	lower							max.	
6, 8	0	-6	0	-9	0	-11	0	-200	0	-200	8	12
10, 12, 13, 16	0	-6	0	-9	0	-13	0	-200	0	-200	8	12
20	0	-7	0	-10	0	-16	0	-200	0	-200	10	15
25, 30	0	-7	0	-10	0	-16	0	-300	0	-300	10	15
35, 38, 40, 50	0	-8	0	-12	0	-19	0	-300	0	-300	12	20
60	0	-9	0	-15	0	-22	0	-300	0	-300	17	25
80	0	-9	0	-15	0	-22	0	-400	0	-400	17	25
100, 120	0	-10	0	-20	0	-25	0	-400	0	-400	20	30

■ Recommended fits for linear ball bearings

Table 3 lists the recommended fits for linear ball bearings.

When a bearing is mounted with a housing, the normal clearance fit should be selected. When the application is highly precise or special, the transition fit should be selected.

For the clearance adjustable and open type bearings, it is best for the shaft diameter to be smaller than the ball complement bore diameter lower deviation, and for the housing bore diameter to be larger than the bearing outside diameter upper deviation.

Table 3 Linear ball bearing recommended fits

Bearing	Tolerance	Shaft tolerance class		Housing bore tolerance class	
		Normal clearance	Close clearance	Clearance fit	Transition fit
SDM, SDB	Upper-class	f 6, g 6	h 6	H 7	JS 7 (J 7)
	Precision-class	f 5, g 5	h 5	H 6	JS 6 (J 6)
SDE	–	h 6	js 6 (j 6)	H 7	JS 7 (J 7)

■ Linear ball bearing clearance

Linear ball bearings provide linear motion smoothly with little wear when the clearance is 0.003 to 0.012 mm. However, when clearance increase due to wear is considered critical, e.g. when the bearing is provided to press die sets, precision machine tools or precision testers; when the bearing becomes unable to slide because of moment; or when smooth bearing operation is needed with no clearance provided, the clearance is adjusted to zero or negative.

In such a case, shafts generally need to be mounted by "selective fitting."

They should be handled carefully so as not to be preloaded excessively.

As Fig. 1 shows, the clearance of bearings with numbers SDM 6 thru SDM 10 can be easily set to

zero or negative, by adjusting one of the three ball rows with a bolt.

Consult with JTEKT on the gauging of linear ball bearings and shafts which should be mounted by "selective fitting," as well as on the whole design of shafts.

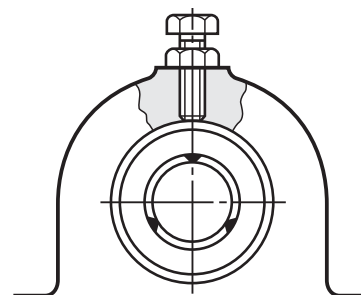

Fig. 1 Clearance adjustment

Table 5 SDE series linear ball bearing tolerances Unit : μm

Bearing number SDE	Ball complement bore diameter (F_w) deviation		Outside diameter (D) deviation		Overall length (L) deviation		B deviation		Eccentricity
	upper	lower	upper	lower	upper	lower	upper	lower	max.
5, 8	+ 8	0	0	- 8	0	- 200	0	- 200	12
10, 12	+ 8	0	0	- 9	0	- 200	0	- 200	12
16	+ 9	- 1	0	- 9	0	- 200	0	- 200	12
20	+ 9	- 1	0	- 11	0	- 200	0	- 200	15
25, 30	+ 11	- 1	0	- 11	0	- 300	0	- 300	15
40, 50	+ 13	- 2	0	- 13	0	- 300	0	- 300	17
60	+ 13	- 2	0	- 15	0	- 400	0	- 400	20
80	+ 16	- 4	0	- 15	0	- 400	0	- 400	20

Linear ball bearings

d 5 ~ (20) mm

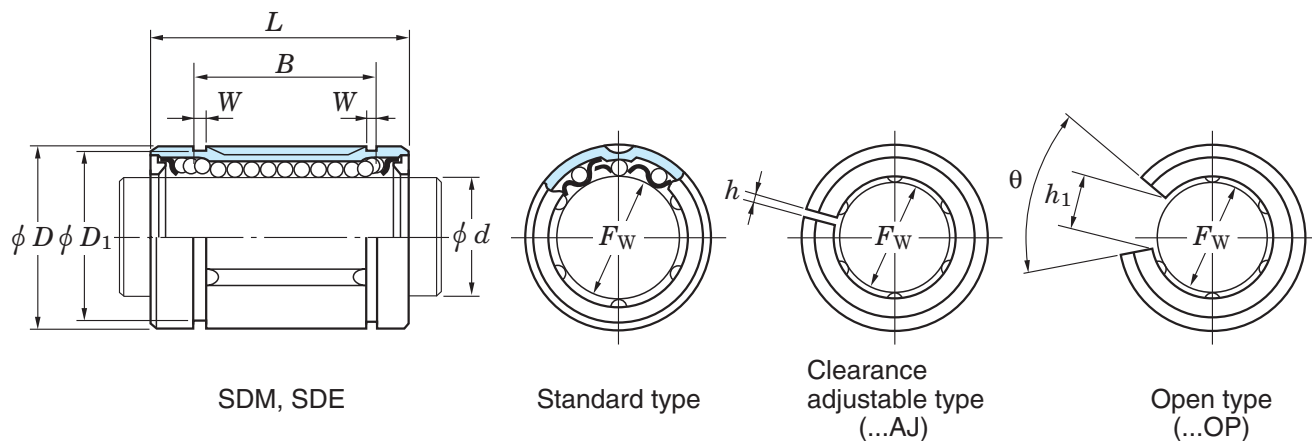

Shaft dia. (mm)	Dimensions (mm)									Bearing No. ¹⁾		
	F_w	D	L	B	W	D_1	h	h_1	θ	Standard type	Clearance adjustable type	Open type
5	5	12	22	14.5	1.1	11.5	—	—	—	SDE5	—	—
6	6	12	19	13.5	1.1	11.5	1	—	—	SDM6	SDM6AJ	—
	6	12	19	13.5	1.1	11.5	1	—	—	SDM6MG	SDM6AJMG	—
8	8	15	17	11.5	1.1	14.3	1	—	—	SDM8S	SDM8SAJ	—
	8	15	17	11.5	1.1	14.3	1	—	—	SDM8SMG	SDM8SAJMG	—
	8	15	24	17.5	1.1	14.3	1	—	—	SDM8	SDM8AJ	—
	8	15	24	17.5	1.1	14.3	1	—	—	SDM8MG	SDM8AJMG	—
	8	16	25	16.5	1.1	15.2	1	—	—	SDE8	SDE8AJ	—
	8	16	25	16.5	1.1	15.2	1	—	—	SDE8MG	SDE8AJMG	—
10	10	19	29	22	1.3	18	1	6.8	80°	SDM10	SDM10AJ	SDM10OP
	10	19	29	22	1.3	18	1	—	—	SDM10MG	SDM8AJMG	—
	10	19	29	22	1.3	18	1	6.8	80°	SDE10	SDE10AJ	SDE10OP
	10	19	29	22	1.3	18	1	—	—	SDE10MG	SDE10AJMG	—
12	12	21	30	23	1.3	20	1.5	8	80°	SDM12	SDM12AJ	SDM12OP
	12	21	30	23	1.3	20	1.5	—	—	SDM12MG	SDM12AJMG	—
	12	22	32	22.9	1.3	21	1.5	7.5	78°	SDE12	SDE12AJ	SDE12OP
	12	22	32	22.9	1.3	21	1.5	—	—	SDE12MG	SDM12AJMG	—
13	13	23	32	23	1.3	22	1.5	9	80°	SDM13	SDM13AJ	SDM13OP
	13	23	32	23	1.3	22	1.5	—	—	SDM13MG	SDM13AJMG	—
16	16	26	36	24.9	1.3	24.9	1.5	10	78°	SDE16	SDE16AJ	SDE16OP
	16	26	36	24.9	1.3	24.9	1.5	—	—	SDE16MG	SDE16AJMG	—
	16	28	37	26.5	1.6	27	1.5	11	80°	SDM16	SDM16AJ	SDM16OP
	16	28	37	26.5	1.6	27	1.5	—	—	SDM16MG	SDM16AJMG	—
20	20	32	42	30.5	1.6	30.5	1.5	11	60°	SDM20	SDM20AJ	SDM20OP
	20	32	42	30.5	1.6	30.5	1.5	—	—	SDM20MG	SDM20AJMG	—

[Note] 1) JTEKT also manufactures sealed types, which are identified by U (one side sealed) or UU (both sides sealed) after ball complement bore diameter number.

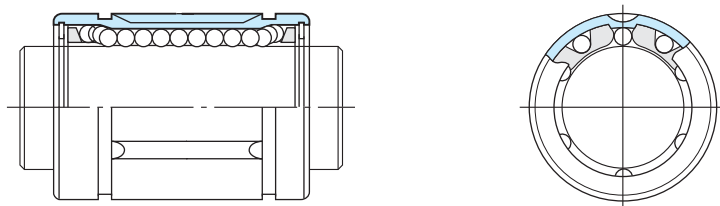

SDM...MD

	No. of ball rows			Basic load ratings (N)		(Refer.) Mass (g)
	Standard type	Clearance adjustable type	Open type	C_r	C_{0r}	Standard type
	3	—	—	108	183	10
	3	3	—	108	186	7
	4	4	—	108	186	6
	3	3	—	96	160	10
	4	4	—	96	160	9
	3	3	—	122	223	14
	4	4	—	134	255	13
	3	3	—	122	223	20
	4	4	—	134	255	18
	4	4	3	259	424	27
	4	4	—	259	424	23
	4	4	3	259	424	27
	4	4	—	259	424	23
	4	4	3	260	431	31
	4	4	—	260	431	27
	4	4	3	289	503	42
	4	4	—	289	503	37
	4	4	3	289	506	41
	4	4	—	289	506	35
	4	4	3	319	587	53
	4	4	—	319	587	47
	4	4	3	480	766	69
	4	4	—	480	766	59
	5	5	4	590	1 010	92
	5	5	—	590	1 010	79

Linear ball bearings

d (20) ~ 80 mm

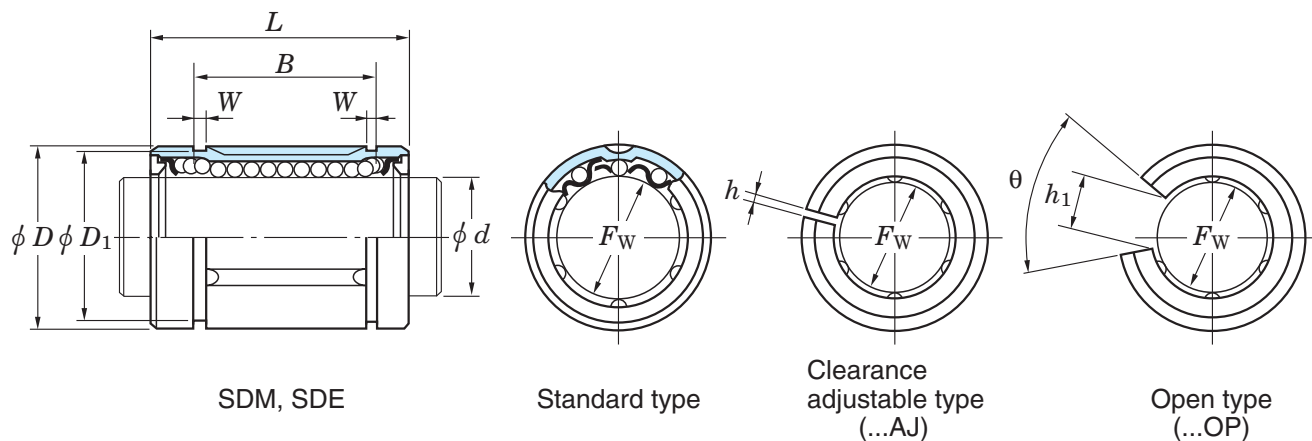

Shaft dia. (mm)	Dimensions (mm)									Bearing No. ¹⁾		
	F_w	D	L	B	W	D_1	h	h_1	θ	Standard type	Clearance adjustable type	Open type
20	20	32	45	31.5	1.6	30.3	2	10	60°	SDE20	SDE20AJ	SDE20OP
	20	32	45	31.5	1.6	30.3	2	—	—	SDE20MG	SDE20AJMG	—
25	25	40	58	44.1	1.85	37.5	2	12.5	60°	SDE25	SDE25AJ	SDE25OP
	25	40	58	44.1	1.85	37.5	2	—	—	SDE25MG	SDE25AJMG	—
	25	40	59	41	1.85	38	2	12	60°	SDM25	SDM25AJ	SDM25OP
	25	40	59	41	1.85	38	2	—	—	SDM25MG	SDM25AJMG	—
30	30	45	64	44.5	1.85	43	2.5	15	50°	SDM30	SDM30AJ	SDM30OP
	30	45	64	44.5	1.85	43	2.5	—	—	SDM30MG	SDM30AJMG	—
	30	47	68	52.1	1.85	44.5	2	12.5	50°	SDE30	SDE30AJ	SDE30OP
	30	47	68	52.1	1.85	44.5	2	—	—	SDE30MG	SDE30AJMG	—
35	35	52	70	49.5	2.1	49	2.5	17	50°	SDM35	SDM35AJ	SDM35OP
	35	52	70	49.5	2.1	49	2.5	—	—	SDM35MG	SDM35AJMG	—
38	38	57	76	58.5	2.1	54.5	3	18	50°	SDM38	SDM38AJ	SDM38OP
40	40	60	80	60.5	2.1	57	3	20	50°	SDM40	SDM40AJ	SDM40OP
	40	60	80	60.5	2.1	57	3	—	—	SDM40MG	SDM40AJMG	—
	40	62	80	60.6	2.15	59	3	16.8	50°	SDE40	SDE40AJ	SDE40OP
	40	62	80	60.6	2.15	59	3	—	—	SDE40MG	SDE40AJMG	—
50	50	75	100	77.6	2.65	72	3	21	50°	SDE50	SDE50AJ	SDE50OP
	50	80	100	74	2.6	76.5	3	25	50°	SDM50	SDM50AJ	SDM50OP
60	60	90	110	85	3.15	86.5	3	30	50°	SDM60	SDM60AJ	SDM60OP
	60	90	125	101.7	3.15	86.5	3	27.2	54°	SDE60	SDE60AJ	SDE60OP
80	80	120	140	105.5	4.15	116	3	40	50°	SDM80	SDM80AJ	SDM80OP
	80	120	165	133.7	4.15	116	3	36.3	54°	SDE80	SDE80AJ	SDE80OP

[Note] 1) JTEKT also manufactures sealed types, which are identified by U (one side sealed) or UU (both sides sealed) after ball complement bore diameter number.

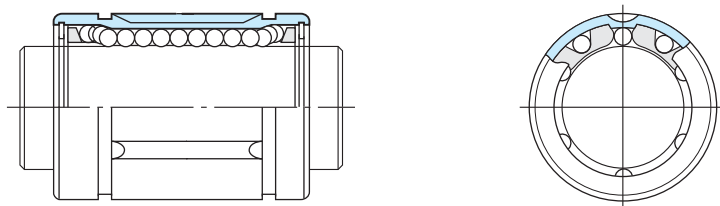

SDM...MD

	No. of ball rows			Basic load ratings (N)		(Refer.) Mass (g)
	Standard type	Clearance adjustable type	Open type	C_r	C_{0r}	Standard type
	5	5	4	590	1 010	96
	5	5	—	590	1 010	88
	5	5	4	1 130	2 030	190
	5	5	—	1 130	2 030	170
	5	5	4	1 130	2 030	200
	5	5	—	1 130	2 030	170
	6	6	5	1 470	2 770	250
	6	6	—	1 470	2 770	220
	6	6	5	1 470	2 770	340
	6	6	—	1 470	2 770	320
	6	6	5	1 580	3 070	370
	6	6	—	1 580	3 070	330
	6	6	5	2 020	3 600	490
	6	6	5	2 180	4 010	590
	6	6	—	2 180	4 010	530
	6	6	5	2 180	4 010	710
	6	6	—	2 180	4 010	650
	6	6	5	4 020	7 110	1 050
	6	6	5	4 420	7 150	1 500
	6	6	5	5 170	9 030	1 850
	6	6	5	6 470	11 100	1 900
	6	6	5	8 180	12 800	4 200
	6	6	5	8 890	14 500	4 800

Linear ball bearings

d 100 ~ 120 mm

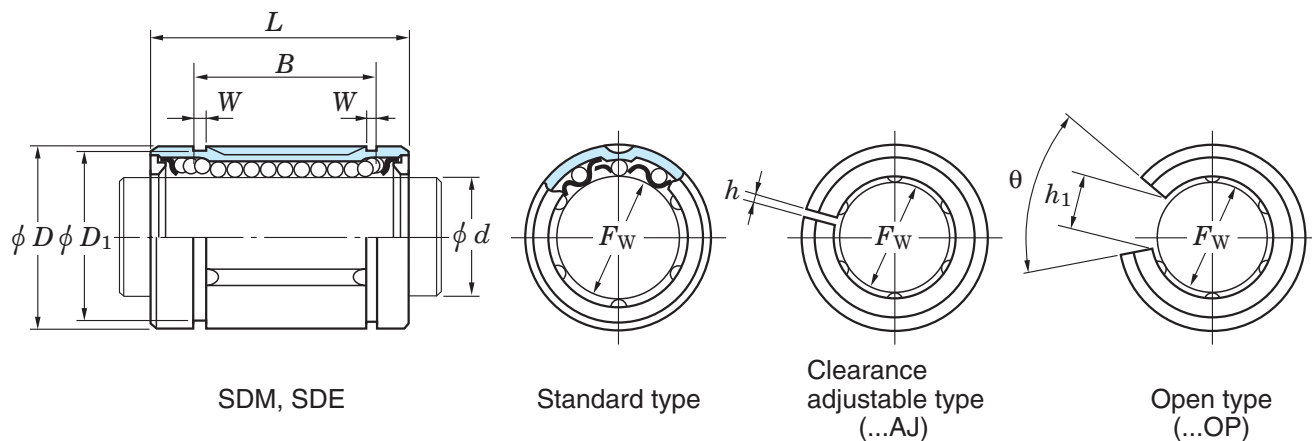

Shaft dia. (mm)	Dimensions (mm)									Bearing No. ¹⁾		
	F_w	D	L	B	W	D_1	h	h_1	θ	Standard type	Clearance adjustable type	Open type
100	100	150	175	125.5	4.15	145	3	50	50°	SDM100	SDM100AJ	SDM100OP
120	120	180	200	158.6	4.15	175	4	85	80°	SDM120	SDM120AJ	SDM120OP

[Note] 1) JTEKT also manufactures sealed types, which are identified by U (one side sealed) or UU (both sides sealed) after ball complement bore diameter number.

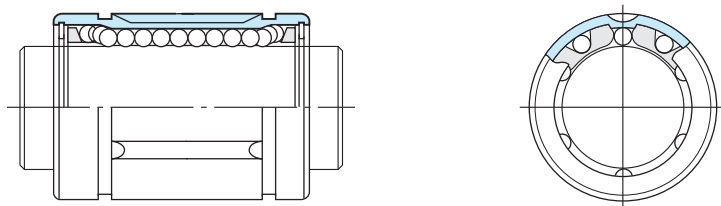

SDM...MD

	No. of ball rows			Basic load ratings (N)		(Refer.) Mass (g)
	Standard type	Clearance adjustable type	Open type	C_r	C_{0r}	Standard type
	6	6	5	12 300	19 700	8 200
	8	8	6	22 300	39 100	15 500

Linear ball bearings flanged type

d 6 ~ 50 mm

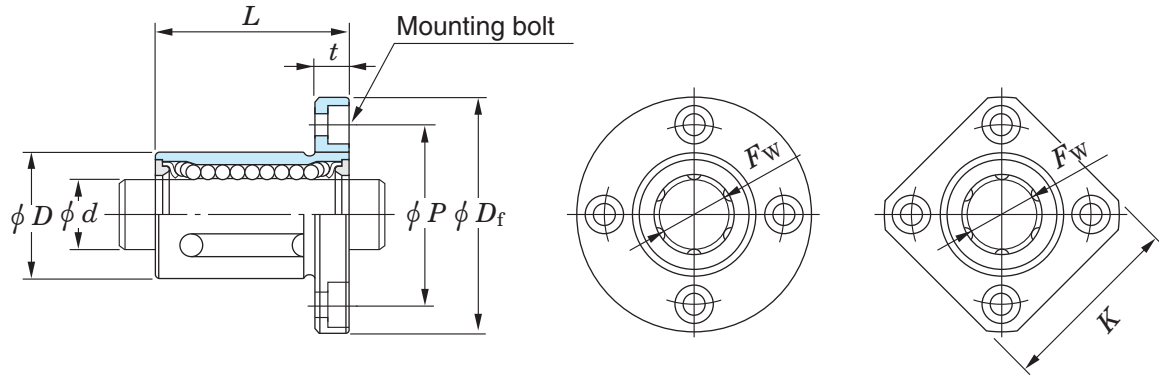

SDMF, SDMK

Round-flanged

Square-flanged

Shaft dia. (mm) d	Dimensions (mm)							Bolt size	Bearing No.	
	F_w	D	L	D_f	K	t	P		Round-flanged type	Square-flanged type
6	6	12	19	28	22	5	20	M3	SDMF6	SDMK6
	6	12	19	28	22	5	20	M3	SDMF6MG	SDMK6MG
8	8	15	24	32	25	5	24	M3	SDMF8	SDMK8
	8	15	24	32	25	5	24	M3	SDMF8MG	SDMK8MG
10	10	19	29	40	30	6	29	M4	SDMF10	SDMK10
	10	19	29	40	30	6	29	M4	SDMF10MG	SDMK10MG
12	12	21	30	42	32	6	32	M4	SDMF12	SDMK12
	12	21	30	42	32	6	32	M4	SDMF12MG	SDMK12MG
13	13	23	32	43	34	6	33	M4	SDMF13	SDMK13
	13	23	32	43	34	6	33	M4	SDMF13MG	SDMK13MG
16	16	28	37	48	37	6	38	M4	SDMF16	SDMK16
	16	28	37	48	37	6	38	M4	SDMF16MG	SDMK16MG
20	20	32	42	54	42	8	43	M5	SDMF20	SDMK20
	20	32	42	54	42	8	43	M5	SDMF20MG	SDMK20MG
25	25	40	59	62	50	8	51	M5	SDMF25	SDMK25
	25	40	59	62	50	8	51	M5	SDMF25MG	SDMK25MG
30	30	45	64	74	58	10	60	M6	SDMF30	SDMK30
	30	45	64	74	58	10	60	M6	SDMF30MG	SDMK30MG
35	35	52	70	82	64	10	67	M6	SDMF35	SDMK35
	35	52	70	82	64	10	67	M6	SDMF35MG	SDMK35MG
40	40	60	80	96	75	13	78	M8	SDMF40	SDMK40
	40	60	80	96	75	13	78	M8	SDMF40MG	SDMK40MG
50	50	80	100	116	92	13	98	M8	SDMF50	SDMK50

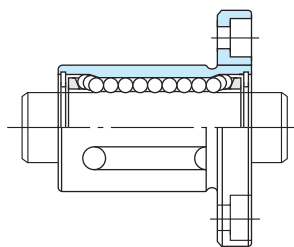

SDMF...MG
SDMK...MG (Synthetic resin)

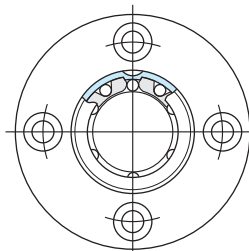

Round-flanged

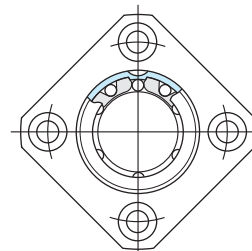

Square-flanged

	No. of ball rows	Basic load ratings (N)		(Refer.) Mass (g)
		C_r	C_{Or}	Round-flanged type
	3	108	186	23
	4	108	186	22
	3	122	223	35
	4	134	255	34
	4	259	424	65
	4	259	424	61
	4	260	431	72
	4	260	431	68
	4	289	506	83
	4	289	506	77
	4	480	766	120
	4	480	766	110
	5	590	1 010	170
	5	590	1 010	160
	5	1 130	2 030	290
	5	1 130	2 030	270
	6	1 470	2 770	440
	6	1 470	2 770	410
	6	1 580	3 070	610
	6	1 580	3 070	560
	6	2 180	4 010	1 000
	6	2 180	4 010	930
	6	4 420	7 150	2 000

Linear ball bearings flanged type

d 60 ~ 80 mm

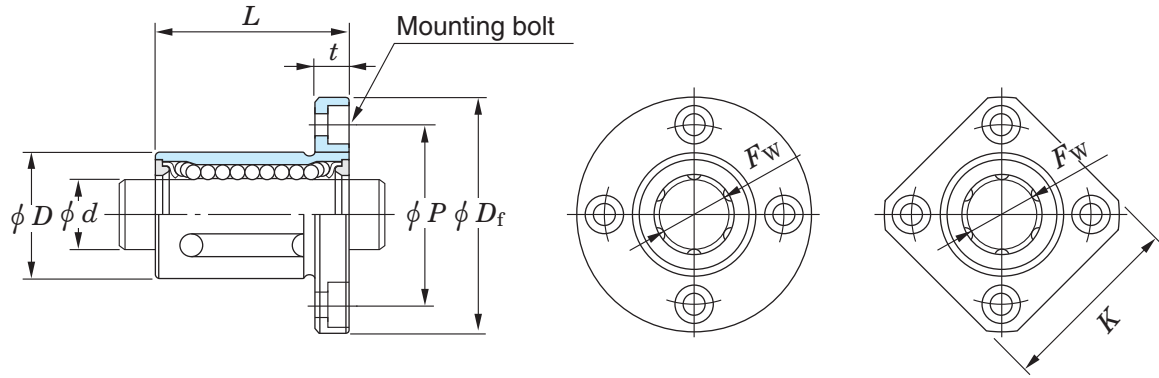

SDMF, SDMK

Round-flanged

Square-flanged

Shaft dia. (mm)	Dimensions (mm)							Bolt size	Bearing No.	
	F_w	D	L	D_f	K	t	P		Round-flanged type	Square-flanged type
60	60	90	110	134	106	18	112	M10	SDMF60	SDMK60
80	80	120	140	164	136	18	142	M10	SDMF80	SDMK80

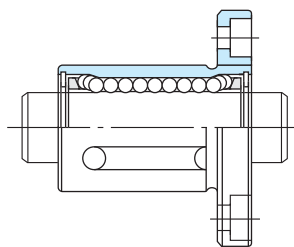

SDMF...MG
SDMK...MG (Synthetic resin)

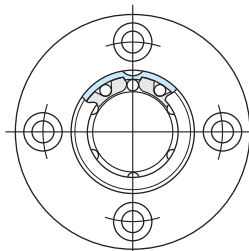

Round-flanged

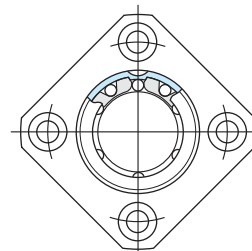

Square-flanged

No. of ball rows	Basic load ratings (N)		(Refer.) Mass (g)
	C_r	C_{0r}	Round-flanged type
6	5 170	9 030	2 800
6	8 180	12 800	5 400

KOYO



Locknuts, lockwashers & lock plates

Bearings are often fit to a shaft with an adapter sleeve, locknut, lockwasher or lock plate.

These accessories make it easy to attach and remove bearings.

They are standardized in JIS.

- Locknuts are standardized such that they can be used with either adapter sleeves, withdrawal sleeves or shafts.
- Lockwashers and lock plates are used as locks on locknuts.

Lockwashers are used with bearings of bore diameter number 40 or lower. Lock plates are used with those of bore diameter 44 or higher.

Locknuts

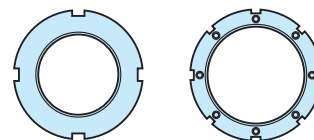

AN (ANL) 02 - 100

HN (HNL) 41 - 110

Lockwashers and lock plates

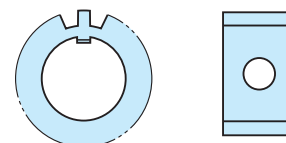

AW (AWL) 00 - 40(X)

AL (ALL) 44 - 100

Locknuts for adapter sleeves and shafts

AN02 ~ 25

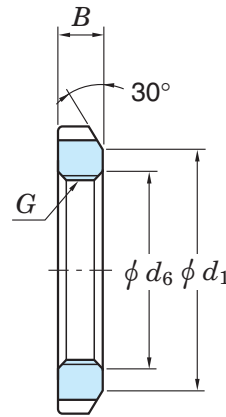
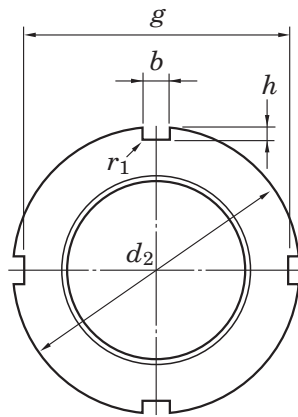

Locknut No.	Thread size ¹⁾ <i>G</i>	Standard dimensions (mm)								(Refer.) Mass (kg)	Applicable ²⁾ adapter sleeve (bore No.)	Applicable ³⁾ lockwasher No.
		<i>d</i> ₂	<i>d</i> ₁	<i>g</i>	<i>d</i> ₆	<i>b</i>	<i>h</i>	<i>B</i>	<i>r</i> _{1 max.}			
AN 02 03 04	M 15×1	25	21	21	15.5	4	2	5	0.4	0.010	—	AW 02
	M 17×1	28	24	24	17.5	4	2	5	0.4	0.013	—	03
	M 20×1	32	26	28	20.5	4	2	6	0.4	0.019	04	04
AN 05 06 07	M 25×1.5	38	32	34	25.8	5	2	7	0.4	0.025	05	AW 05
	M 30×1.5	45	38	41	30.8	5	2	7	0.4	0.043	06	06
	M 35×1.5	52	44	48	35.8	5	2	8	0.4	0.053	07	07
AN 08 09 10	M 40×1.5	58	50	53	40.8	6	2.5	9	0.5	0.085	08	AW 08
	M 45×1.5	65	56	60	45.8	6	2.5	10	0.5	0.119	09	09
	M 50×1.5	70	61	65	50.8	6	2.5	11	0.5	0.148	10	10
AN 11 12 13	M 55×2	75	67	69	56	7	3	11	0.5	0.158	11	AW 11
	M 60×2	80	73	74	61	7	3	11	0.5	0.174	12	12
	M 65×2	85	79	79	66	7	3	12	0.5	0.203	13	13
AN 14 15 16	M 70×2	92	85	85	71	8	3.5	12	0.5	0.242	14	AW 14
	M 75×2	98	90	91	76	8	3.5	13	0.5	0.287	15	15
	M 80×2	105	95	98	81	8	3.5	15	0.6	0.397	16	16
AN 17 18 19	M 85×2	110	102	103	86	8	3.5	16	0.6	0.451	17	AW 17
	M 90×2	120	108	112	91	10	4	16	0.6	0.556	18	18
	M 95×2	125	113	117	96	10	4	17	0.6	0.658	19	19
AN 20 21 22	M100×2	130	120	122	101	10	4	18	0.6	0.698	20	AW 20
	M105×2	140	126	130	106	12	5	18	0.7	0.845	21	21
	M110×2	145	133	135	111	12	5	19	0.7	0.965	22	22
AN 23 24 25	M115×2	150	137	140	116	12	5	19	0.7	1.01	—	AW 23
	M120×2	155	138	145	121	12	5	20	0.7	1.08	24	24
	M125×2	160	148	150	126	12	5	21	0.7	1.19	—	25

[Notes] 1) Basic profile and dimension of screw thread are in accordance with JIS B 0205.

2) Applicable to adapter sleeve series A31, A2, A3 and A23.

3) Applicable to lockwashers with flat inner tongue.

[Remark] Locknut series AN is used for adapter assembly series H2, H3, H23 and H31, while locknut series ANL is used for adapter assembly series H30.

AN 26 ~ 40

ANL24 ~ 40

Locknut No.	Thread size ¹⁾ <i>G</i>	Standard dimensions (mm)								(Refer.) Mass (kg)	Applicable ²⁾ adapter sleeve (bore No.)	Applicable ³⁾ lockwasher No.
		<i>d</i> ₂	<i>d</i> ₁	<i>g</i>	<i>d</i> ₆	<i>b</i>	<i>h</i>	<i>B</i>	<i>r</i> ₁ max.			
AN 26	M130×2	165	149	155	131	12	5	21	0.7	1.25	26	AW 26
AN 27 28	M135×2	175	160	163	136	14	6	22	0.7	1.55	—	AW 27
	M140×2	180	160	168	141	14	6	22	0.7	1.56	28	28
AN 29 30 31	M145×2	190	172	178	146	14	6	24	0.7	1.80	—	AW 29
	M150×2	195	171	183	151	14	6	24	0.7	2.03	30	30
	M155×3	200	182	186	156.5	16	7	25	0.7	2.30	—	—
AN 32 33 34	M160×3	210	182	196	161.5	16	7	25	0.7	2.59	32	AW 32
	M165×3	210	193	196	166.5	16	7	26	0.7	2.70	—	—
	M170×3	220	193	206	171.5	16	7	26	0.7	2.80	34	34
AN 36 38 40	M180×3	230	203	214	181.5	18	8	27	0.7	3.07	36	AW 36
	M190×3	240	214	224	191.5	18	8	28	0.7	3.39	38	38
	M200×3	250	226	234	201.5	18	8	29	0.7	3.69	40	40
ANL24 26 28	M120×2	145	133	135	121	12	5	20	0.7	0.78	24	AWL24
	M130×2	155	143	145	131	12	5	21	0.7	0.88	26	26
	M140×2	165	151	153	141	14	6	22	0.7	0.99	28	28
ANL30 32 34	M150×2	180	164	168	151	14	6	24	0.7	1.33	30	AWL30
	M160×3	190	174	176	161.5	16	7	25	0.7	1.56	32	32
	M170×3	200	184	186	171.5	16	7	26	0.7	1.72	34	34
ANL36 38 40	M180×3	210	192	194	181.5	18	8	27	0.7	1.95	36	AWL36
	M190×3	220	202	204	191.5	18	8	28	0.7	2.08	38	38
	M200×3	240	218	224	201.5	18	8	29	0.7	2.98	40	40

Locknuts

for adapter sleeves and shafts

AN 44 ~ 100

ANL 44 ~ 76

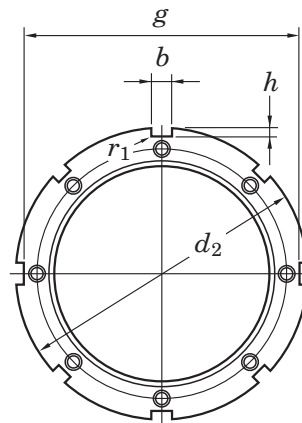
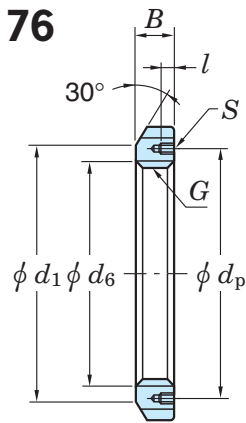

Locknut No.	Thread size ¹⁾ G	Standard dimensions (mm)								Tapped hole ²⁾ (mm)			(Refer.) Mass (kg)	Applicable adapter sleeve ³⁾ (bore No.)	Applicable lock plate No.
		d_2	d_1	g	d_6	b	h	B	$r_{1 \text{ max.}}$	l	S Thread size	d_p			
AN 44 48 52	Tr220×4	280	250	260	222	20	10	32	0.8	15	M 8×1.25	238	5.16	44	AL 44
	Tr240×4	300	270	280	242	20	10	34	0.8	15	M 8×1.25	258	5.91	48	44
	Tr260×4	330	300	306	262	24	12	36	0.8	18	M10×1.5	281	7.99	52	52
AN 56 60 64	Tr280×4	350	320	326	282	24	12	38	0.8	18	M10×1.5	301	8.99	56	AL 52
	Tr300×4	380	340	356	302	24	12	40	0.8	18	M10×1.5	326	11.7	60	60
	Tr320×5	400	360	376	322.5	24	12	42	0.8	18	M10×1.5	345	13.0	64	64
AN 68 72 76	Tr340×5	440	400	410	342.5	28	15	55	1	21	M12×1.75	372	23.0	68	AL 68
	Tr360×5	460	420	430	362.5	28	15	58	1	21	M12×1.75	392	25.0	72	68
	Tr380×5	490	450	454	382.5	32	18	60	1	21	M12×1.75	414	30.8	76	76
AN 80 84 88	Tr400×5	520	470	484	402.5	32	18	62	1	27	M16×2	439	36.7	80	AL 80
	Tr420×5	540	490	504	422.5	32	18	70	1	27	M16×2	459	43.3	84	80
	Tr440×5	560	510	520	442.5	36	20	70	1	27	M16×2	477	45.1	88	88
AN 92 96 100	Tr460×5	580	540	540	462.5	36	20	75	1	27	M16×2	497	50.2	92	AL 88
	Tr480×5	620	560	580	482.5	36	20	75	1	27	M16×2	527	62.0	96	96
	Tr500×5	630	580	584	502.5	40	23	80	1	27	M16×2	539	63.1	/500	100
ANL44 48 52	Tr220×4	260	242	242	222	20	9	30	0.8	12	M 6×1	229	3.09	44	ALL44
	Tr240×4	290	270	270	242	20	10	34	0.8	15	M 8×1.25	253	5.16	48	48
	Tr260×4	310	290	290	262	20	10	34	0.8	15	M 8×1.25	273	5.67	52	48
ANL56 60 64	Tr280×4	330	310	310	282	24	10	38	0.8	15	M 8×1.25	293	6.78	56	ALL56
	Tr300×4	360	336	336	302	24	12	42	0.8	15	M 8×1.25	316	9.62	60	60
	Tr320×5	380	356	356	322.5	24	12	42	0.8	15	M 8×1.25	335	9.94	64	64
ANL68 72 76	Tr340×5	400	376	376	342.5	24	12	45	1	15	M 8×1.25	355	11.7	68	ALL64
	Tr360×5	420	394	394	362.5	28	13	45	1	15	M 8×1.25	374	12.0	72	72
	Tr380×5	450	422	422	382.5	28	14	48	1	18	M10×1.5	398	14.9	76	76

[Notes] 1) Basic profile and dimension of screw thread are in accordance with JIS B 0216.
 2) Basic profile and dimension of bore with internal thread are in accordance with JIS B 0205.
 3) Applicable to adapter sleeve series A31, A32, A23 and A30.

ANL 80 ~ 100

Locknut No.	Thread ¹⁾ size <i>G</i>	Standard dimensions (mm)									Tapped hole ²⁾ (mm)			(Refer.) Mass (kg)	Applicable adapter sleeve ³⁾ (bore No.)	Applicable lock plate No.
		<i>d</i> ₂	<i>d</i> ₁	<i>g</i>	<i>d</i> ₆	<i>b</i>	<i>h</i>	<i>B</i>	<i>r</i> ₁ max.	<i>l</i>	<i>S</i> Thread size	<i>d</i> _p				
ANL80	Tr400×5	470	442	442	402.5	28	14	52	1	18	M10×1.5	418	16.9	80	ALL76	
84	Tr420×5	490	462	462	422.5	32	14	52	1	18	M10×1.5	438	17.4	84	84	
88	Tr440×5	520	490	490	442.5	32	15	60	1	21	M12×1.75	462	26.2	88	88	
ANL92	Tr460×5	540	510	510	462.5	32	15	60	1	21	M12×1.75	482	26.9	92	ALL88	
96	Tr480×5	560	530	530	482.5	36	15	60	1	21	M12×1.75	502	28.3	96	96	
100	Tr500×5	580	550	550	502.5	36	15	68	1	21	M12×1.75	522	33.6	/500	96	

Locknuts for withdrawal sleeves

HN 42 ~ 110

HNL 41 ~ 64

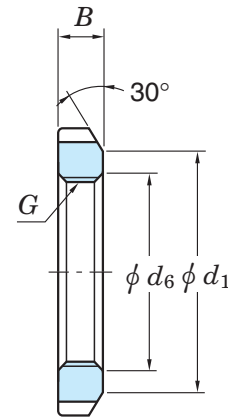
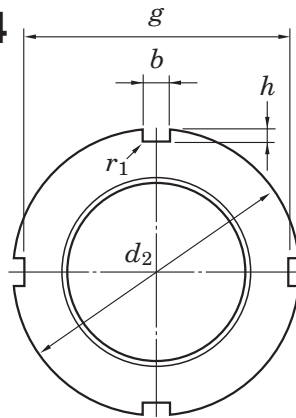

Locknut No.	Thread ¹⁾ size G	Standard dimensions (mm)								(Refer.) Mass (kg)	Withdrawal sleeve No.				
		d ₂	d ₁	g	d ₆	b	h	B	r ₁ max.						
HN 42	Tr210×4	270	238	250	212	20	10	30	0.8	4.75	AH3138	AH2238	AH3238	AH2338	
	44	Tr220×4	280	250	260	222	20	10	32	0.8	5.35	3140	2240	3240	2340
	48	Tr240×4	300	270	280	242	20	10	34	0.8	6.20	3144	2244	—	2344
HN 52	Tr260×4	330	300	306	262	24	12	36	0.8	8.55	AH3148	AH2248	—	AH2348	
	58	Tr290×4	370	330	346	292	24	12	40	0.8	11.8	3152	2252	—	2352
	62	Tr310×5	390	350	366	312.5	24	12	42	0.8	13.4	3156	2256	—	2356
HN 66	Tr330×5	420	380	390	332.5	28	15	52	1	20.4	AH3160	AH2260	AH3260	—	
	70	Tr350×5	450	410	420	352.5	28	15	55	1	25.2	3164	2264	3264	—
	74	Tr370×5	470	430	440	372.5	28	15	58	1	28.2	3168	—	3268	—
HN 80	Tr400×5	520	470	484	402.5	32	18	62	1	40.0	AH3172	—	AH3272	—	
	84	Tr420×5	540	490	504	422.5	32	18	70	1	46.9	3176	—	3276	—
	88	Tr440×5	560	510	520	442.5	36	20	70	1	48.5	3180	—	3280	—
HN 92	Tr460×5	580	540	540	462.5	36	20	75	1	55.0	AH3184	—	AH3284	—	
	96	Tr480×5	620	560	580	482.5	36	20	75	1	67.0	X3188	—	X3288	—
	102	Tr510×6	650	590	604	513	40	23	80	1	75.0	X3192	—	X3292	—
HN 106	Tr530×6	670	610	624	533	40	23	80	1	78.0	AHX3196	—	AHX3296	—	
	110	Tr550×6	700	640	654	553	40	23	80	1	92.5	X31/500	—	X32/500	—
HNL 41	Tr205×4	250	232	234	207	18	8	30	0.8	3.43	AH3038	AH238	—	—	
	43	Tr215×4	260	242	242	217	20	9	30	0.8	3.72	3040	240	—	—
	47	Tr235×4	280	262	262	237	20	9	34	0.8	4.60	3044	244	—	—
HNL 52	Tr260×4	310	290	290	262	20	10	34	0.8	5.80	AH3048	AH248	—	—	
	56	Tr280×4	330	310	310	282	24	10	38	0.8	6.72	3052	252	—	—
	60	Tr300×4	360	336	336	302	24	12	42	0.8	9.60	3056	256	—	—
HNL 64	Tr320×5	380	356	356	322.5	24	12	42	1	10.3	AH3060	—	—	—	

[Note] 1) Basic profile and dimension of screw thread are in accordance with JIS B 0216.

[Remark] Number of slots on nut may sometimes exceed that shown in the figure.

HNL 69 ~ 108

Locknut No.	Thread ¹⁾ size <i>G</i>	Standard dimensions (mm)									(Refer.) Mass (kg)	Withdrawal sleeve No.			
		<i>d</i> ₂	<i>d</i> ₁	<i>g</i>	<i>d</i> ₆	<i>b</i>	<i>h</i>	<i>B</i>	<i>r</i> ₁ max.						
HNL 69 73	Tr345×5	410	384	384	347.5	28	13	45	1	11.5	3064	—	—	—	
	Tr365×5	430	404	404	367.5	28	13	48	1	14.2	3068	—	—	—	
HNL 77 82 86	Tr385×5	450	422	422	387.5	28	14	48	1	15.0	AH3072	—	—	—	
	Tr410×5	480	452	452	412.5	32	14	52	1	19.0	3076	—	—	—	
	Tr430×5	500	472	472	432.5	32	14	52	1	19.8	3080	—	—	—	
HNL 90 94 98	Tr450×5	520	490	490	452.5	32	15	60	1	23.8	AH3084	—	—	—	
	Tr470×5	540	510	510	472.5	32	15	60	1	25.0	X3088	—	—	—	
	Tr490×5	580	550	550	492.5	36	15	60	1	34.0	X3092	—	—	—	
HNL104 108	Tr520×6	600	570	570	523	36	15	68	1	37.0	AHX3096	—	—	—	
	Tr540×6	630	590	590	543	40	20	68	1	43.5	X30/500	—	—	—	

Lockwashers

AW 00 ~ 24(X)

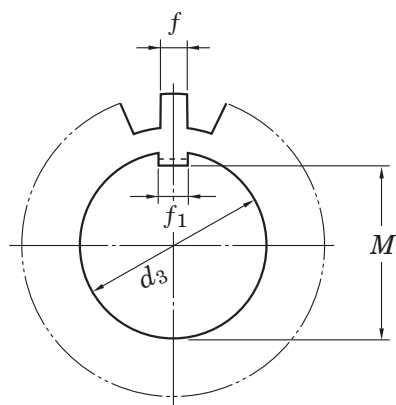

With bent inner tongue

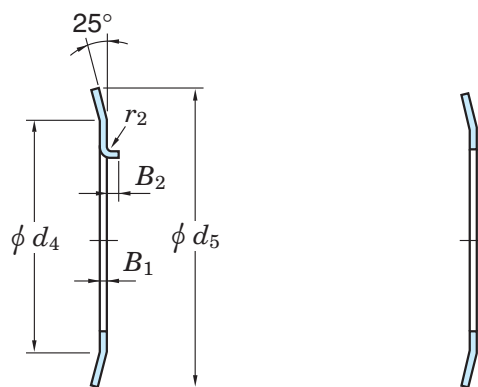

With flat inner tongue

Lockwasher No.	Standard dimensions (mm)											No. of tooth	(Refer.) Mass (kg/100pcs.)	Applicable adapter sleeve (bore No.)	Applicable locknut No.
	With bent inner tongue	With flat inner tongue	d_3	M	f_1	B_1	f	d_4	d_5	r_2	B_2				
AW 00	AW 00X	10	8.5	3	1	3	13	21	0.5	2	9	0.131	—	AN 00	
01	01X	12	10.5	3	1	3	17	25	0.5	2	9	0.192	—	01	
02	02X	15	13.5	4	1	4	21	28	1	2.5	13	0.253	—	02	
AW 03	AW 03X	17	15.5	4	1	4	24	32	1	2.5	13	0.313	—	AN 03	
04	04X	20	18.5	4	1	4	26	36	1	2.5	13	0.350	04	04	
05	05X	25	23	5	1.2	5	32	42	1	2.5	13	0.640	05	05	
AW 06	AW 06X	30	27.5	5	1.2	5	38	49	1	2.5	13	0.780	06	AN 06	
07	07X	35	32.5	6	1.2	5	44	57	1	2.5	15	1.04	07	07	
08	08X	40	37.5	6	1.2	6	50	62	1	2.5	15	1.23	08	08	
AW 09	AW 09X	45	42.5	6	1.2	6	56	69	1	2.5	17	1.52	09	AN 09	
10	10X	50	47.5	6	1.2	6	61	74	1	2.5	17	1.60	10	10	
11	11X	55	52.5	8	1.2	7	67	81	1	4	17	1.96	11	11	
AW 12	AW 12X	60	57.5	8	1.5	7	73	86	1.2	4	17	2.53	12	AN 12	
13	13X	65	62.5	8	1.5	7	79	92	1.2	4	19	2.90	13	13	
14	14X	70	66.5	8	1.5	8	85	98	1.2	4	19	3.34	14	14	
AW 15	AW 15X	75	71.5	8	1.5	8	90	104	1.2	4	19	3.56	15	AN 15	
16	16X	80	76.5	10	1.8	8	95	112	1.2	4	19	4.64	16	16	
17	17X	85	81.5	10	1.8	8	102	119	1.2	4	19	5.24	17	17	
AW 18	AW 18X	90	86.5	10	1.8	10	108	126	1.2	4	19	6.23	18	AN 18	
19	19X	95	91.5	10	1.8	10	113	133	1.2	4	19	6.70	19	19	
20	20X	100	96.5	12	1.8	10	120	142	1.2	6	19	7.65	20	20	
AW 21	AW 21X	105	100.5	12	1.8	12	126	145	1.2	6	19	8.26	21	AN 21	
22	22X	110	105.5	12	1.8	12	133	154	1.2	6	19	9.40	22	22	
23	23X	115	110.5	12	2	12	137	159	1.5	6	19	10.8	—	23	
AW 24	AW 24X	120	115	14	2	12	138	164	1.5	6	19	10.5	24	AN 24	

[Remark] 1) AW00~AW40, AW00X~AW40X are applicable to adapter assembly series H31, H2, H3 and H23.

2) AWL24~AWL40, AWL24X~AWL40X are applied to adapter assembly series H30.

3) For adapter sleeves with narrow slits, lockwashers with flat inner tongue should be used. Either type of lockwasher can be used for adapter sleeves with wide slits.

AW 25 ~ 40(X)

AWL24 ~ 40(X)

Lockwasher No.		Standard dimensions (mm)										No. of tooth	(Refer.) Mass (kg/100pcs.)	Applicable adapter sleeve (bore No.)	Applicable locknut No.
		<i>d</i> ₃	<i>M</i>	<i>f</i> ₁	<i>B</i> ₁	<i>f</i>	<i>d</i> ₄	<i>d</i> ₅	<i>r</i> ₂	<i>B</i> ₂					
AW 25 26	AW 25X 26X	125	120	14	2	12	148	170	1.5	6	19	11.8	—	25	
		130	125	14	2	12	149	175	1.5	6	19	11.3	26	26	
AW 27 28 29	AW 27X 28X 29X	135	130	14	2	14	160	185	1.5	6	19	14.4	—	AN 27	
		140	135	16	2	14	160	192	1.5	8	19	14.2	28	28	
		145	140	16	2	14	172	202	1.5	8	19	16.8	—	29	
AW 30 31 32	AW 30X 31X 32X	150	145	16	2	14	171	205	1.5	8	19	15.5	30	AN 30	
		155	147.5	16	2.5	16	182	212	1.5	8	19	20.9	—	31	
		160	154	18	2.5	16	182	217	1.5	8	19	22.2	32	32	
AW 33 34 36	AW 33X 34X 36X	165	157.5	18	2.5	16	193	222	1.5	8	19	24.1	—	AN 33	
		170	164	18	2.5	16	193	232	1.5	8	19	24.7	34	34	
		180	174	20	2.5	18	203	242	1.5	8	19	26.8	36	36	
AW 38 40	AW 38X 40X	190	184	20	2.5	18	214	252	1.5	8	19	27.8	38	AN 38	
		200	194	20	2.5	18	226	262	1.5	8	19	29.3	40	40	
AWL24 26 28	AWL24X 26X 28X	120	115	14	2	12	133	155	1.5	6	19	7.70	24	ANL24	
		130	125	14	2	12	143	165	1.5	6	19	8.70	26	26	
		140	135	16	2	14	151	175	1.5	8	19	10.9	28	28	
AWL30 32 34	AWL30X 32X 34X	150	145	16	2	14	164	190	1.5	8	19	11.3	30	ANL30	
		160	154	18	2.5	16	174	200	1.5	8	19	16.2	32	32	
		170	164	18	2.5	16	184	210	1.5	8	19	19.0	34	34	
AWL36 38 40	AWL36X 38X 40X	180	174	20	2.5	18	192	220	1.5	8	19	18.0	36	ANL36	
		190	184	20	2.5	18	202	230	1.5	8	19	20.5	38	38	
		200	194	20	2.5	18	218	250	1.5	8	19	21.4	40	40	

Lock plates

AL 44 ~ 100

ALL44 ~ 96

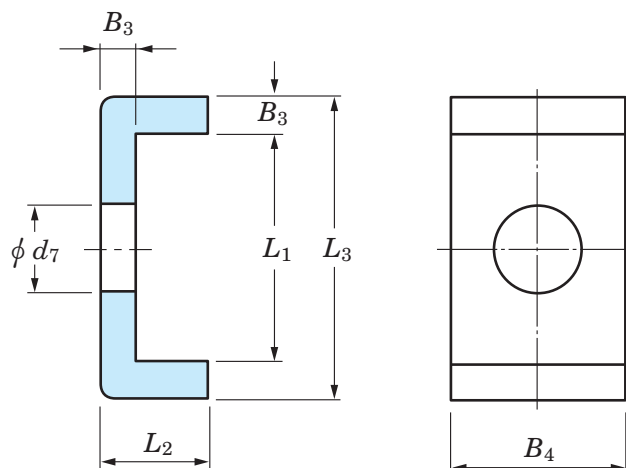

Lock plate No.	Standard dimensions (mm)						(Refer.) Mass (kg/100pcs.)	Applicable locknut No.
	B_3	B_4	L_2	d_7	L_1	L_3		
AL 44	4	20	12	9	22.5	30.5	2.60	AN 44,48
52	4	24	12	12	25.5	33.5	3.39	52,56
60	4	24	12	12	30.5	38.5	3.79	60
AL 64	5	24	15	12	31	41	5.35	AN 64
68	5	28	15	14	38	48	6.65	68,72
76	5	32	15	14	40	50	7.96	76
AL 80	5	32	15	18	45	55	8.20	AN 80,84
88	5	36	15	18	43	53	9.00	88,92
96	5	36	15	18	53	63	10.4	96
100	5	40	15	18	45	55	10.5	100
ALL44	4	20	12	7	13.5	21.5	2.12	ANL44
48	4	20	12	9	17.5	25.5	2.29	48,52
56	4	24	12	9	17.5	25.5	2.92	56
ALL60	4	24	12	9	20.5	28.5	3.16	ANL60
64	5	24	15	9	21	31	4.56	64,68
72	5	28	15	9	20	30	5.03	72
ALL76	5	28	15	12	24	34	5.28	ANL76,80
84	5	32	15	12	24	34	6.11	84
88	5	32	15	14	28	38	6.45	88,92
96	5	36	15	14	28	38	7.29	96,100

[Remark] Lock plate series AL are applicable to adapter assembly series H31, H32 and H23, while lock plate series ALL are applicable to H30.

18	90	150	-	-	-	60	-	2	160	22	30	-	40	52.4	69	1.1	2	190	30	43	-	64	73	2	3	225	54	90	4	
19	95	160	-	-	-	65	-	2	170	24	32	-	43	55.6	75	1.1	2.1	200	33	45	-	67	77.8	2	3	240	55	95	4	
20	100	165	21	30	39	65	1.1	2	180	25	34	-	46	60.3	80	1.5	2.1	215	36	47	51	73	82.6	2.1	3	250	58	98	4	
21	105	175	22	33	42	69	1.1	2	190	27	36	-	50	65.1	85	1.5	2.1	225	37	49	53	77	87.3	2.1	3	260	60	100	4	
22	110	180	22	33	42	69	1.1	2	200	28	38	-	53	69.8	90	1.5	2.1	240	42	50	57	80	92.1	3	3	280	65	108	4	
24	120	200	25	38	48	62	80	1.5	2	215	-	40	42	58	76	95	-	2.1	260	44	55	62	86	106	3	3	310	72	118	5
26	130	210	25	38	48	64	80	1.5	2	230	-	40	46	64	80	100	-	3	280	48	58	66	93	112	3	4	340	78	128	5
28	140	225	27	40	50	68	85	1.5	2.1	250	-	42	50	68	88	109	-	3	300	50	62	70	102	118	4	4	360	82	132	5
30	150	250	31	46	60	80	100	2	2.1	270	-	45	54	73	96	118	-	3	320	-	65	75	108	128	-	4	380	85	138	5
32	160	270	34	51	66	86	109	2	2.1	290	-	48	58	80	104	128	-	3	340	-	68	79	114	136	-	4	400	88	142	5
34	170	280	34	51	66	88	109	2	2.1	310	-	52	62	86	110	140	-	4	360	-	72	84	120	140	-	4	420	92	145	5
36	180	300	37	56	72	96	118	2.1	3	320	-	52	62	86	112	140	-	4	380	-	75	88	126	150	-	4	440	95	150	6
38	190	320	42	60	78	104	128	3	3	340	-	55	65	92	120	150	-	4	400	-	78	92	132	155	-	5	460	98	155	6
40	200	340	44	65	82	112	140	3	3	360	-	58	70	98	128	160	-	4	420	-	80	97	138	165	-	5	480	102	160	6
44	220	370	48	69	88	120	150	3	4	400	-	65	78	108	144	180	-	4	460	-	88	106	145	180	-	5	540	115	180	6
48	240	400	50	74	95	128	160	4	4	440	-	72	85	120	160	200	-	4	500	-	95	114	155	195	-	5	580	122	190	6
52	260	440	57	82	106	144	180	4	4	480	-	80	90	130	174	218	-	5	540	-	102	123	165	206	-	6	620	132	206	7.5
56	280	460	57	82	106	146	180	4	5	500	-	80	90	130	176	218	-	5	560	-	108	132	175	224	-	6	670	140	224	7.5
60	300	500	63	90	118	160	200	5	5	540	-	85	98	140	192	243	-	5	620	-	109	140	185	236	-	7.5	710	150	236	7.5
64	320	540	71	100	128	176	218	5	5	580	-	92	105	150	208	258	-	5	670	-	112	155	200	258	-	7.5	750	155	250	9.5
68	340	580	78	106	140	190	243	5	5	620	-	92	118	165	224	280	-	6	710	-	118	165	212	272	-	7.5	800	165	265	9.5
72	360	600	78	106	140	192	243	5	5	650	-	95	122	170	232	290	-	6	750	-	125	170	224	290	-	7.5	850	180	280	9.5
76	380	620	78	106	140	194	243	5	5	680	-	95	122	175	240	300	-	6	780	-	128	175	230	300	-	7.5	900	190	300	9.5
80	400	650	80	112	145	200	250	6	6	720	-	103	140	185	256	315	-	6	820	-	136	185	243	308	-	7.5	950	200	315	12
84	420	700	88	122	165	224	280	6	6	760	-	109	150	195	272	335	-	7.5	850	-	136	190	250	315	-	9.5	980	206	325	12
88	440	720	88	122	165	226	280	6	6	790	-	112	155	200	280	345	-	7.5	900	-	145	200	265	345	-	9.5	1030	212	335	12
92	460	760	95	132	175	240	300	6	7.5	830	-	118	165	212	296	365	-	7.5	950	-	155	212	280	365	-	9.5	1060	218	345	12
96	480	790	100	136	180	248	308	6	7.5	870	-	125	170	224	310	388	-	7.5	980	-	160	218	290	375	-	9.5	1120	230	365	15
/500	500	830	106	145	190	264	325	7.5	7.5	920	-	136	185	243	336	412	-	7.5	1030	-	170	230	300	388	-	12	1150	236	375	15
/530	530	870	109	150	195	272	335	7.5	7.5	980	-	145	200	258	355	450	-	9.5	1090	-	180	243	325	412	-	12	1220	250	400	15
/560	560	920	115	160	206	280	355	7.5	7.5	1030	-	150	206	272	365	475	-	9.5	1150	-	190	258	335	438	-	12	1280	258	412	15
/600	600	980	122	170	218	300	375	7.5	7.5	1090	-	155	212	280	388	488	-	9.5	1220	-	200	272	355	462	-	15	1360	272	438	15
/630	630	1030	128	175	230	315	400	7.5	7.5	1150	-	165	230	300	412	515	-	12	1280	-	206	280	375	488	-	15	1420	280	450	15
/670	670	1090	136	185	243	336	412	7.5	7.5	1220	-	175	243	315	438	545	-	12	1360	-	218	300	400	515	-	15	1500	290	475	15
/710	710	1150	140	195	250	345	438	9.5	9.5	1280	-	180	250	325	450	560	-	12	1420	-	224	308	412	530	-	15	-	-	-	-
/750	750	1220	150	206	272	365	475	9.5	9.5	1360	-	195	265	345	475	615	-	15	1500	-	236	325	438	560	-	15	-	-	-	-
/800	800	1280	155	212	272	375	475	9.5	9.5	1420	-	200	272	355	488	615	-	15	1600	-	258	355	462	600	-	15	-	-	-	-
/850	850	1360	165	224	290	400	500	12	12	1500	-	206	280	375	515	650	-	15	1700	-	272	375	488	630	-	19	-	-	-	-
/900	900	1420	165	230	300	412	515	12	12	1580	-	218	300	388	515	670	-	15	1780	-	280	388	500	650	-	19	-	-	-	-
/950	950	1500	175	243	315	438	545	12	12	1660	-	230	315	412	530	710	-	15	1850	-	290	400	515	670	-	19	-	-	-	-
/1000	1000	1580	185	258	335	462	580	12	12	1750	-	243	330	425	560	750	-	15	1950	-	300	412	545	710	-	19	-	-	-	-
/1060	1060	1660	190	265	345	475	600	12	15	-	-	-	-	-	-	-	-	-	-	-	-	-	-	-	-	-	-	-	-	-
/1120	1120	1750	-	280	365	475	630	-	15	-	-	-	-	-	-	-	-	-	-	-	-	-	-	-	-	-	-	-	-	-
/1180	1180	1850	-	290	388	500	670	-	15	-	-	-	-	-	-	-	-	-	-	-	-	-	-	-	-	-	-	-	-	-
/1250	1250	1950	-	308	400	530	710	-	15	-	-	-	-	-	-	-	-	-	-	-	-	-	-	-	-	-	-	-	-	-
/1320	1320	2060	-	325	425	560	750	-	15	-	-	-	-	-	-	-	-	-	-	-	-	-	-	-	-	-	-	-	-	-
/1400	1400	2180	-	345	450	580	775	-	19	-	-	-	-	-	-	-	-	-	-	-	-	-	-	-	-	-	-	-	-	-
/1500	1500	2300	-	355	462	600	800	-	19	-	-	-	-	-	-	-	-	-	-	-	-	-	-	-	-	-	-	-	-	-

[Remark] The chamfer dimensions (r) in this table are not always applicable to the following corners.

(a) Snap ring groove side corner of outer ring with snap ring groove. (b) No-rib side bearing ring corner of thin section cylindrical roller bearing.

(c) Front bearing ring corner of angular contact ball bearing. (d) Inner ring corner of tapered bore bearing.

Supplementary table 2 Boundary dimensions of tapered roller bearings

Tapered roller bearing		329						320				330			331							
Bore dia. No.	Bore dia. <i>d</i>	Diameter series 9						Diameter series 0							Diameter series 1							
		Outside dia. <i>D</i>	Dimension series 29			Chamfer		Outside dia. <i>D</i>	Dimension series 20			Dimension series 30		Chamfer		Outside dia. <i>D</i>	Dimension series 31			Chamfer		
			<i>T</i>	<i>B</i>	<i>C</i>	Inner ring <i>r</i> min.	Outer ring		<i>T</i>	<i>B</i>	<i>C</i>	<i>T</i>	<i>B</i>	<i>C</i>	Inner ring <i>r</i> min.		Outer ring	<i>T</i>	<i>B</i>	<i>C</i>	Inner ring <i>r</i> min.	Outer ring
00	10																					
01	12																					
02	15																					
03	17	–	–	–	–	–	–	–	–	–	–	–	–	–	–	–	–	–	–	–	–	
04	20	37	12	12	9	0.3	0.3	42	15	15	12	–	–	–	0.6	0.6	–	–	–	–	–	
/22	22	40	12	12	9	0.3	0.3	44	15	15	11.5	–	–	–	0.6	0.6	–	–	–	–	–	
05	25	42	12	12	9	0.3	0.3	47	15	15	11.5	17	17	14	0.6	0.6	–	–	–	–	–	
/28	28	45	12	12	9	0.3	0.3	52	16	16	12	–	–	–	1	1	–	–	–	–	–	
06	30	47	12	12	9	0.3	0.3	55	17	17	13	20	20	16	1	1	–	–	–	–	–	
/32	32	52	14	15	10	0.6	0.6	58	17	17	13	–	–	–	1	1	–	–	–	–	–	
07	35	55	14	14	11.5	0.6	0.6	62	18	18	14	21	21	17	1	1	–	–	–	–	–	
08	40	62	15	15	12	0.6	0.6	68	19	19	14.5	22	22	18	1	1	75	26	26	20.5	1.5	1.5
09	45	68	15	15	12	0.6	0.6	75	20	20	15.5	24	24	19	1	1	80	26	26	20.5	1.5	1.5
10	50	72	15	15	12	0.6	0.6	80	20	20	15.5	24	24	19	1	1	85	26	26	20	1.5	1.5
11	55	80	17	17	14	1	1	90	23	23	17.5	27	27	21	1.5	1.5	95	30	30	23	1.5	1.5
12	60	85	17	17	14	1	1	95	23	23	17.5	27	27	21	1.5	1.5	100	30	30	23	1.5	1.5
13	65	90	17	17	14	1	1	100	23	23	17.5	27	27	21	1.5	1.5	110	34	34	26.5	1.5	1.5
14	70	100	20	20	16	1	1	110	25	25	19	31	31	25.5	1.5	1.5	120	37	37	29	2	1.5
15	75	105	20	20	16	1	1	115	25	25	19	31	31	25.5	1.5	1.5	125	37	37	29	2	1.5
16	80	110	20	20	16	1	1	125	29	29	22	36	36	29.5	1.5	1.5	130	37	37	29	2	1.5
17	85	120	23	23	18	1.5	1.5	130	29	29	22	36	36	29.5	1.5	1.5	140	41	41	32	2.5	2
18	90	125	23	23	18	1.5	1.5	140	32	32	24	39	39	32.5	2	1.5	150	45	45	35	2.5	2
19	95	130	23	23	18	1.5	1.5	145	32	32	24	39	39	32.5	2	1.5	160	49	49	38	2.5	2
20	100	140	25	25	20	1.5	1.5	150	32	32	24	39	39	32.5	2	1.5	165	52	52	40	2.5	2
21	105	145	25	25	20	1.5	1.5	160	35	35	26	43	43	34	2.5	2	175	56	56	44	2.5	2
22	110	150	25	25	20	1.5	1.5	170	38	38	29	47	47	37	2.5	2	180	56	56	43	2.5	2
24	120	165	29	29	23	1.5	1.5	180	38	38	29	48	48	38	2.5	2	200	62	62	48	2.5	2
26	130	180	32	32	25	2	1.5	200	45	45	34	55	55	43	2.5	2	–	–	–	–	–	–
28	140	190	32	32	25	2	1.5	210	45	45	34	56	56	44	2.5	2	–	–	–	–	–	–
30	150	210	38	38	30	2.5	2	225	48	48	36	59	59	46	3	2.5	–	–	–	–	–	–
32	160	220	38	38	30	2.5	2	240	51	51	38	–	–	–	3	2.5	–	–	–	–	–	–
34	170	230	38	38	30	2.5	2	260	57	57	43	–	–	–	3	2.5	–	–	–	–	–	–
36	180	250	45	45	34	2.5	2	280	64	64	48	–	–	–	3	2.5	–	–	–	–	–	–
38	190	260	45	45	34	2.5	2	290	64	64	48	–	–	–	3	2.5	–	–	–	–	–	–
40	200	280	51	51	39	3	2.5	310	70	70	53	–	–	–	3	2.5	–	–	–	–	–	–
44	220	300	51	51	39	3	2.5	340	76	76	57	–	–	–	4	3	–	–	–	–	–	–
48	240	320	51	51	39	3	2.5	360	76	76	57	–	–	–	4	3	–	–	–	–	–	–
52	260	360	63.5	63.5	48	3	2.5	400	87	87	65	–	–	–	5	4	–	–	–	–	–	–
56	280	380	63.5	63.5	48	3	2.5	420	87	87	65	–	–	–	5	4	–	–	–	–	–	–
60	300	420	76	76	57	4	3	460	100	100	74	–	–	–	5	4	–	–	–	–	–	–
64	320	440	76	76	57	4	3	480	100	100	74	–	–	–	5	4	–	–	–	–	–	–
68	340	460	76	76	57	4	3	–	–	–	–	–	–	–	–	–	–	–	–	–	–	–
72	360	480	76	76	57	4	3	–	–	–	–	–	–	–	–	–	–	–	–	–	–	–

[Remark] In the new JIS, new dimension series (classified by contact angle) is also specified in accordance with ISO standards.

Unit : mm

		302			322			332					303 , 303D					313			323					Tapered roller bearing		
		Diameter series 2											Diameter series 3											Bore dia. No.				
Outside dia.	D	Dimension series 02			Dimension series 22			Dimension series 32			Chamfer		Outside dia.	Dimension series 03					Dimension series 13			Dimension series 23				Chamfer		
		T	B	C	T	B	C	T	B	C	Inner ring	Outer ring		T	B	C	C ₃₀₃	C _{303D}	T	B	C	T	B	C	Inner ring	Outer ring	r min.	d
	-	-	-	-	-	-	-	-	-	-	-	-	-	-	-	-	-	-	-	-	-	-	-	-	-	-	10	00
	-	-	-	-	-	-	-	-	-	-	-	-	-	-	-	-	-	-	-	-	-	-	-	-	-	-	12	01
	(35	11.75	11	10)	-	-	-	-	-	-	-	-	-	42	14.25	13	11	-	-	-	-	-	-	-	1	1	15	02
	40	13.25	12	11	17.25	16	14	-	-	-	1	1	47	15.25	14	12	-	-	-	-	-	-	-	1	1	17	03	
	47	15.25	14	12	19.25	18	15	-	-	-	1	1	52	16.25	15	13	-	-	-	-	-	-	1.5	1.5	20	04		
	50	-	-	-	-	-	-	-	-	-	-	-	56	-	-	-	-	-	-	-	-	-	-	-	-	22	/22	
	52	16.25	15	13	19.25	18	16 ²⁾	22	22	18	1	1	62	18.25	17	15	13	-	-	-	-	-	1.5	1.5	25	05		
	58	-	-	-	(20.25	19	16) ¹⁾	24	24	19	1	1	68	-	-	-	-	-	-	-	-	-	-	-	-	28	/28	
	62	17.25	16	14	21.25	20	17	25	25	19.5	1	1	72	20.75	19	16	14	-	-	-	-	-	1.5	1.5	30	06		
	65	18.25	17	15	(22	21.5	17) ¹⁾	26	26	20.5	1	1	75	-	-	-	-	-	-	-	-	-	1.5	1.5	32	/32		
	72	18.25	17	15	24.25	23	19	28	28	22	1.5	1.5	80	22.75	21	18	15	-	-	-	-	-	2	1.5	35	07		
	80	19.75	18	16	24.75	23	19	32	32	25	1.5	1.5	90	25.25	23	20	17	-	-	-	-	-	2	1.5	40	08		
	85	20.75	19	16	24.75	23	19	32	32	25	1.5	1.5	100	27.25	25	22	18	-	-	-	-	-	2	1.5	45	09		
	90	21.75	20	17	24.75	23	19 ³⁾	32	32	24.5	1.5	1.5	110	29.25	27	23	19	-	-	-	-	-	2.5	2	50	10		
	100	22.75	21	18	26.75	25	21	35	35	27	2	1.5	120	31.5	29	25	21	-	-	-	-	-	2.5	2	55	11		
	110	23.75	22	19	29.75	28	24	38	38	29	2	1.5	130	33.5	31	26	22	-	-	-	-	-	2.5	2.5	60	12		
	120	24.75	23	20	32.75	31	27	41	41	32	2	1.5	140	36	33	28	23	-	-	-	-	-	2.5	2.5	65	13		
	125	26.25	24	21	33.25	31	27	41	41	32	2	1.5	150	38	35	30	25	-	-	-	-	-	2.5	2.5	70	14		
	130	27.25	25	22	33.25	31	27	41	41	31	2	1.5	160	40	37	31	26	-	-	-	-	-	2.5	2.5	75	15		
	140	28.25	26	22	35.25	33	28	46	46	35	2.5	2	170	42.5	39	33	27	-	-	-	-	-	2.5	2.5	80	16		
	150	30.5	28	24	38.5	36	30	49	49	37	2.5	2	180	44.5	41	34	28	-	-	-	-	-	3	3	85	17		
	160	32.5	30	26	42.5	40	34	55	55	42	2.5	2	190	46.5	43	36	30	-	-	-	-	-	3	3	90	18		
	170	34.5	32	27	45.5	43	37	58	58	44	3	2.5	200	49.5	45	38	32	-	-	-	-	-	3	3	95	19		
	180	37	34	29	49	46	39	63	63	48	3	2.5	215	51.5	47	39	-	56.5	51	35	77.5	73	60	4	3	100	20	
	190	39	36	30	53	50	43	68	68	52	3	2.5	225	53.5	49	41	-	58	53	36	81.5	77	63	4	3	105	21	
	200	41	38	32	56	53	46	-	-	-	3	2.5	240	54.5	50	42	-	63	57	38	84.5	80	65	4	3	110	22	
	215	43.5	40	34	61.5	58	50	-	-	-	3	2.5	260	59.5	55	46	-	68	62	42	90.5	86	69	4	3	120	24	
	230	43.75	40	34	67.75	64	54	-	-	-	4	3	280	63.75	58	49	-	72	66	44	-	-	-	5	4	130	26	
	250	45.75	42	36	71.75	68	58	-	-	-	4	3	300	67.75	62	53	-	77	70	47	-	-	-	5	4	140	28	
	270	49	45	38	77	73	60	-	-	-	4	3	320	72	65	55	-	82	75	50	-	-	-	5	4	150	30	
	290	52	48	40	84	80	67	-	-	-	4	3	340	75	68	58	-	-	-	-	-	-	-	5	4	160	32	
	310	57	52	43	91	86	71	-	-	-	5	4	360	80	72	62	-	-	-	-	-	-	-	5	4	170	34	
	320	57	52	43	91	86	71	-	-	-	5	4	-	-	-	-	-	-	-	-	-	-	-	-	-	180	36	
	340	60	55	46	97	92	75	-	-	-	5	4	-	-	-	-	-	-	-	-	-	-	-	-	-	190	38	
	360	64	58	48	104	98	82	-	-	-	5	4	-	-	-	-	-	-	-	-	-	-	-	-	-	200	40	
	-	-	-	-	-	-	-	-	-	-	-	-	-	-	-	-	-	-	-	-	-	-	-	-	-	220	44	
	-	-	-	-	-	-	-	-	-	-	-	-	-	-	-	-	-	-	-	-	-	-	-	-	-	240	48	
	-	-	-	-	-	-	-	-	-	-	-	-	-	-	-	-	-	-	-	-	-	-	-	-	-	260	52	
	-	-	-	-	-	-	-	-	-	-	-	-	-	-	-	-	-	-	-	-	-	-	-	-	-	280	56	
	-	-	-	-	-	-	-	-	-	-	-	-	-	-	-	-	-	-	-	-	-	-	-	-	-	300	60	
	-	-	-	-	-	-	-	-	-	-	-	-	-	-	-	-	-	-	-	-	-	-	-	-	-	320	64	
	-	-	-	-	-	-	-	-	-	-	-	-	-	-	-	-	-	-	-	-	-	-	-	-	-	340	68	
	-	-	-	-	-	-	-	-	-	-	-	-	-	-	-	-	-	-	-	-	-	-	-	-	-	360	72	

- [Notes] 1) Bearing group with large contact angle
 2) Outer ring width C of bearings with large contact angle is 15 mm.
 3) Outer ring width C of bearings with large contact angle is 18 mm.

44	220	250	14	-	22	1	270	23	30	37	267	223	1.1	300	36	48	63	297	224	2	360	63	85	112	355	225	4	420	90	122	160	415	225	6	500	170	7.5	
48	240	270	14	-	22	1	300	27	36	45	297	243	1.5	340	45	60	78	335	244	2.1	380	63	85	112	375	245	4	440	90	122	160	435	245	6	540	180	7.5	
52	260	290	14	-	22	1	320	27	36	45	317	263	1.5	360	45	60	79	355	264	2.1	420	73	95	130	415	265	5	480	100	132	175	475	265	6	580	190	9.5	
56	280	310	14	-	22	1	350	32	42	53	347	283	1.5	380	45	60	80	375	284	2.1	440	73	95	130	435	285	5	520	109	145	190	515	285	6	620	206	9.5	
60	300	340	18	24	30	1	380	36	48	62	376	304	2	420	54	73	95	415	304	3	480	82	109	140	475	305	5	540	109	145	190	535	305	6	670	224	9.5	
64	320	360	18	24	30	1	400	36	48	63	396	324	2	440	54	73	95	435	325	3	500	82	109	140	495	325	5	580	118	155	205	575	325	7.5	710	236	9.5	
68	340	380	18	24	30	1	420	36	48	64	416	344	2	460	54	73	96	455	345	3	540	90	122	160	535	345	5	620	125	170	220	615	345	7.5	750	243	12	
72	360	400	18	24	30	1	440	36	48	65	436	364	2	500	63	85	110	495	365	4	560	90	122	160	555	365	5	640	125	170	220	635	365	7.5	780	250	12	
76	380	420	18	24	30	1	460	36	48	65	456	384	2	520	63	85	112	515	385	4	600	100	132	175	595	385	6	670	132	175	224	665	385	7.5	820	265	12	
80	400	440	18	24	30	1	480	36	48	65	476	404	2	540	63	85	112	535	405	4	620	100	132	175	615	405	6	710	140	185	243	705	405	7.5	850	272	12	
84	420	460	18	24	30	1	500	36	48	65	495	424	2	580	73	95	130	575	425	5	650	103	140	180	645	425	6	730	140	185	243	725	425	7.5	900	290	15	
88	440	480	18	24	30	1	540	45	60	80	535	444	2.1	600	73	95	130	595	445	5	680	109	145	190	675	445	6	780	155	206	265	775	445	9.5	950	308	15	
92	460	500	18	24	30	1	560	45	60	80	555	464	2.1	620	73	95	130	615	465	5	710	112	150	195	705	465	6	800	155	206	265	795	465	9.5	980	315	15	
96	480	520	18	24	30	1	580	45	60	80	575	484	2.1	650	78	103	135	645	485	5	730	112	150	195	725	485	6	850	165	224	290	845	485	9.5	1000	315	15	
/500	500	540	18	24	30	1	600	45	60	80	595	504	2.1	670	78	103	135	665	505	5	750	112	150	195	745	505	6	870	165	224	290	865	505	9.5	1060	335	15	
/530	530	580	23	30	38	1.1	640	50	67	85	635	534	3	710	82	109	140	705	535	5	800	122	160	212	795	535	7.5	920	175	236	308	915	535	9.5	1090	335	15	
/560	560	610	23	30	38	1.1	670	50	67	85	665	564	3	750	85	115	150	745	565	5	850	132	175	224	845	565	7.5	980	190	250	335	975	565	12	1150	355	15	
/600	600	650	23	30	38	1.1	710	50	67	85	705	604	3	800	90	122	160	795	605	5	900	136	180	236	895	605	7.5	1030	195	258	335	1025	605	12	1220	375	15	
/630	630	680	23	30	38	1.1	750	54	73	95	745	634	3	850	100	132	175	845	635	6	950	145	190	250	945	635	9.5	1090	206	280	365	1085	635	12	1280	388	15	
/670	670	730	27	36	45	1.5	800	58	78	105	795	674	4	900	103	140	180	895	675	6	1000	150	200	258	995	675	9.5	1150	218	290	375	1145	675	15	1320	388	15	
/710	710	780	32	42	53	1.5	850	63	85	112	845	714	4	950	109	145	190	945	715	6	1060	160	212	272	1055	715	9.5	1220	230	308	400	1215	715	15	1400	412	15	
/750	750	820	32	42	53	1.5	900	67	90	120	895	755	4	1000	112	150	195	995	755	6	1120	165	224	290	1115	755	9.5	1280	236	315	412	1275	755	15				
/800	800	870	32	42	53	1.5	950	67	90	120	945	805	4	1060	118	155	205	1055	805	7.5	1180	170	230	300	1175	805	9.5	1360	250	335	438	1355	805	15				
/850	850	920	32	42	53	1.5	1000	67	90	120	995	855	4	1120	122	160	212	1115	855	7.5	1250	180	243	315	1245	855	12	1440	-	354	-	-	-	15				
/900	900	980	36	48	63	2	1060	73	95	130	1055	905	5	1180	125	170	220	1175	905	7.5	1320	190	250	335	1315	905	12	1520	-	372	-	-	-	15				
/950	950	1030	36	48	63	2	1120	78	103	135	1115	955	5	1250	136	180	236	1245	955	7.5	1400	200	272	355	1395	955	12	1600	-	390	-	-	-	15				
/1000	1000	1090	41	54	70	2.1	1180	82	109	140	1175	1005	5	1320	145	190	250	1315	1005	9.5	1460	-	276	-	-	-	-	12	1670	-	402	-	-	-	15			
/1060	1060	1150	41	54	70	2.1	1250	85	115	150	1245	1065	5	1400	155	206	265	1395	1065	9.5								1770	-	426	-	-	-	15				
/1120	1120	1220	45	60	80	2.1	1320	90	122	160	1315	1125	5	1460	-	206	-	-	-	9.5								1860	-	444	-	-	-	15				
/1180	1180	1280	45	60	80	2.1	1400	100	132	175	1395	1185	6	1520	-	206	-	-	-	9.5								1950	-	462	-	-	-	19				
/1250	1250	1360	50	67	85	3	1460	-	-	175	1455	1255	6	1610	-	216	-	-	-	9.5																		
/1320	1320	1440	-	-	95	3	1540	-	-	175	1535	1325	6	1700	-	228	-	-	-	9.5																		
/1400	1400	1520	-	-	95	3	1630	-	-	180	1620	1410	6																									
/1500	1500	1630	-	-	105	4	1750	-	-	195	1740	1510	6																									
/1600	1600	1730	-	-	105	4	1850	-	-	195	1840	1610	6																									
/1700	1700	1840	-	-	112	4	1970	-	-	212	1960	1710	7.5																									
/1800	1800	1950	-	-	120	4	2080	-	-	220	2070	1810	7.5																									
/1900	1900	2060	-	-	130	5	2180	-	-	220	2170	1910	7.5																									
/2000	2000	2160	-	-	130	5	2300	-	-	236	2290	2010	7.5																									
/2120	2120	2300	-	-	140	5	2430	-	-	243	2420	2130	7.5																									
/2240	2240	2430	-	-	150	5	2570	-	-	258	2560	2250	9.5																									
/2360	2360	2550	-	-	150	5	2700	-	-	265	2690	2370	9.5																									
/2500	2500	2700	-	-	160	5	2850	-	-	272	2840	2510	9.5																									

Supplementary table 4 Boundary dimensions of double direction thrust ball bearings

Bore dia. No.	522									523									
	Diameter series 2									Diameter series 3									
	Dimension series 22									Dimension series 23									
	Bore dia. d_2	Out-side dia. D	Height T_1	Central race height B	d_3 max.	D_1 min.	r min.	r_1 min.	(Refer.) $d^{1)}$	Bore dia. d_2	Out-side dia. D	Height T_1	Central race height B	d_3 max.	D_1 min.	r min.	r_1 min.	(Refer.) $d^{1)}$	
02	10	32	22	5	32	17	0.6	0.3	15	10	–	–	–	–	–	–	–	–	
04	15	40	26	6	40	22	0.6	0.3	20	15	–	–	–	–	–	–	–	–	
05	20	47	28	7	47	27	0.6	0.3	25	20	52	34	8	52	27	1	0.3	25	
06	25	52	29	7	52	32	0.6	0.3	30	25	60	38	9	60	32	1	0.3	30	
07	30	62	34	8	62	37	1	0.3	35	30	68	44	10	68	37	1	0.3	35	
08	30	68	36	9	68	42	1	0.6	40	30	78	49	12	78	42	1	0.6	40	
09	35	73	37	9	73	47	1	0.6	45	35	85	52	12	85	47	1	0.6	45	
10	40	78	39	9	78	52	1	0.6	50	40	95	58	14	95	52	1.1	0.6	50	
11	45	90	45	10	90	57	1	0.6	55	45	105	64	15	105	57	1.1	0.6	55	
12	50	95	46	10	95	62	1	0.6	60	50	110	64	15	110	62	1.1	0.6	60	
13	55	100	47	10	100	67	1	0.6	65	55	115	65	15	115	67	1.1	0.6	65	
14	55	105	47	10	105	72	1	1	70	55	125	72	16	125	72	1.1	1	70	
15	60	110	47	10	110	77	1	1	75	60	135	79	18	135	77	1.5	1	75	
16	65	115	48	10	115	82	1	1	80	65	140	79	18	140	82	1.5	1	80	
17	70	125	55	12	125	88	1	1	85	70	150	87	19	150	88	1.5	1	85	
18	75	135	62	14	135	93	1.1	1	90	75	155	88	19	155	93	1.5	1	90	
20	85	150	67	15	150	103	1.1	1	100	85	170	97	21	170	103	1.5	1	100	
22	95	160	67	15	160	113	1.1	1	110	95	190	110	24	189.5	113	2	1	110	
24	100	170	68	15	170	123	1.1	1.1	120	100	210	123	27	209.5	123	2.1	1.1	120	
26	110	190	80	18	189.5	133	1.5	1.1	130	110	225	130	30	224	134	2.1	1.1	130	
28	120	200	81	18	199.5	143	1.5	1.1	140	120	240	140	31	239	144	2.1	1.1	140	
30	130	215	89	20	214.5	153	1.5	1.1	150	130	250	140	31	249	154	2.1	1.1	150	
32	140	225	90	20	224.5	163	1.5	1.1	160	140	270	153	33	269	164	3	1.1	160	
34	150	240	97	21	239.5	173	1.5	1.1	170	150	280	153	33	279	174	3	1.1	170	
36	150	250	98	21	249	183	1.5	2	180	150	300	165	37	299	184	3	2	180	
38	160	270	109	24	269	194	2	2	190	160	320	183	40	319	195	4	2	190	
40	170	280	109	24	279	204	2	2	200	170	340	192	42	339	205	4	2	200	
44	190	300	110	24	299	224	2	2	220	–	–	–	–	–	–	–	–	–	

[Note] 1) Nominal bore diameter of single direction bearings of the same diameter series and with the same nominal outside diameter.

(with flat back faces)

Unit : mm

524										Bore dia. No.
Diameter series 4										
Dimension series 24										
Bore dia. d_2	Out-side dia. D	Height T_1	Central race height B	d_3 max.	D_1 min.	r min.	r_1 min.	(Refer.) $d^{1)}$		
—	—	—	—	—	—	—	—	—	—	02
—	—	—	—	—	—	—	—	—	—	04
15	60	45	11	60	27	1	0.6	25		05
20	70	52	12	70	32	1	0.6	30		06
25	80	59	14	80	37	1.1	0.6	35		07
30	90	65	15	90	42	1.1	0.6	40		08
35	100	72	17	100	47	1.1	0.6	45		09
40	110	78	18	110	52	1.5	0.6	50		10
45	120	87	20	120	57	1.5	0.6	55		11
50	130	93	21	130	62	1.5	0.6	60		12
50	140	101	23	140	68	2	1	65		13
55	150	107	24	150	73	2	1	70		14
60	160	115	26	160	78	2	1	75		15
65	170	120	27	170	83	2.1	1	80		16
65	180	128	29	179.5	88	2.1	1.1	85		17
70	190	135	30	189.5	93	2.1	1.1	90		18
80	210	150	33	209.5	103	3	1.1	100		20
90	230	166	37	229	113	3	1.1	110		22
95	250	177	40	249	123	4	1.5	120		24
100	270	192	42	269	134	4	2	130		26
110	280	196	44	279	144	4	2	140		28
120	300	209	46	299	154	4	2	150		30
130	320	226	50	319	164	5	2	160		32
135	340	236	50	339	174	5	2.1	170		34
140	360	245	52	359	184	5	3	180		36
—	—	—	—	—	—	—	—	—		38
—	—	—	—	—	—	—	—	—		40
—	—	—	—	—	—	—	—	—		44

Supplementary table 5 (1) Dimension of snap ring grooves and locating snap rings

Applicable bearing		Snap ring groove									
Bore dia. <i>d</i>		Outside dia. <i>D</i>	Snap ring groove dia. <i>D</i> ₁		Position of snap ring groove <i>a</i>				Snap ring groove width <i>b</i>		Fillet radius of snap ring groove <i>r</i> ₀
Dimension series			max.	min.	Dimension series 18		Dimension series 19		max.	min.	max.
18	19				max.	min.	max.	min.			
–	10	22	20.8	20.5	–	–	1.05	0.9	1.05	0.8	0.2
–	12	24	22.8	22.5	–	–	1.05	0.9	1.05	0.8	0.2
–	15	28	26.7	26.4	–	–	1.3	1.15	1.2	0.95	0.25
–	17	30	28.7	28.4	–	–	1.3	1.15	1.2	0.95	0.25
20	–	32	30.7	30.4	1.3	1.15	–	–	1.2	0.95	0.25
22	–	34	32.7	32.4	1.3	1.15	–	–	1.2	0.95	0.25
25	20	37	35.7	35.4	1.3	1.15	1.7	1.55	1.2	0.95	0.25
–	22	39	37.7	37.4	–	–	1.7	1.55	1.2	0.95	0.25
28	–	40	38.7	38.4	1.3	1.15	–	–	1.2	0.95	0.25
30	25	42	40.7	40.4	1.3	1.15	1.7	1.55	1.2	0.95	0.25
32	–	44	42.7	42.4	1.3	1.15	–	–	1.2	0.95	0.25
–	28	45	43.7	43.4	–	–	1.7	1.55	1.2	0.95	0.25
35	30	47	45.7	45.4	1.3	1.15	1.7	1.55	1.2	0.95	0.25
40	32	52	50.7	50.4	1.3	1.15	1.7	1.55	1.2	0.95	0.25
–	35	55	53.7	53.4	–	–	1.7	1.55	1.2	0.95	0.25
45	–	58	56.7	56.4	1.3	1.15	–	–	1.2	0.95	0.25
–	40	62	60.7	60.3	–	–	1.7	1.55	1.2	0.95	0.25
50	–	65	63.7	63.3	1.3	1.15	–	–	1.2	0.95	0.25
–	45	68	66.7	66.3	–	–	1.7	1.55	1.2	0.95	0.25
55	50	72	70.7	70.3	1.7	1.55	1.7	1.55	1.2	0.95	0.25
60	–	78	76.2	75.8	1.7	1.55	–	–	1.6	1.3	0.4
–	55	80	77.9	77.5	–	–	2.1	1.9	1.6	1.3	0.4
65	60	85	82.9	82.5	1.7	1.55	2.1	1.9	1.6	1.3	0.4
70	65	90	87.9	87.5	1.7	1.55	2.1	1.9	1.6	1.3	0.4
75	–	95	92.9	92.5	1.7	1.55	–	–	1.6	1.3	0.4
80	70	100	97.9	97.5	1.7	1.55	2.5	2.3	1.6	1.3	0.4
–	75	105	102.6	102.1	–	–	2.5	2.3	1.6	1.3	0.4
85	80	110	107.6	107.1	2.1	1.9	2.5	2.3	1.6	1.3	0.4
90	–	115	112.6	112.1	2.1	1.9	–	–	1.6	1.3	0.4
95	85	120	117.6	117.1	2.1	1.9	3.3	3.1	1.6	1.3	0.4
100	90	125	122.6	122.1	2.1	1.9	3.3	3.1	1.6	1.3	0.4
105	95	130	127.6	127.1	2.1	1.9	3.3	3.1	1.6	1.3	0.4
110	100	140	137.6	137.1	2.5	2.3	3.3	3.1	2.2	1.9	0.6
–	105	145	142.6	142.1	–	–	3.3	3.1	2.2	1.9	0.6
120	110	150	147.6	147.1	2.5	2.3	3.3	3.1	2.2	1.9	0.6
130	120	165	161.8	161.3	3.3	3.1	3.7	3.5	2.2	1.9	0.6
140	–	175	171.8	171.3	3.3	3.1	–	–	2.2	1.9	0.6
–	130	180	176.8	176.3	–	–	3.7	3.5	2.2	1.9	0.6
150	140	190	186.8	186.3	3.3	3.1	3.7	3.5	2.2	1.9	0.6
160	–	200	196.8	196.3	3.3	3.1	–	–	2.2	1.9	0.6

[Remark] Minimum chamfer dimension tolerances on snap ring groove-side outer ring are as follows :
 Bearings belonging to dimension series 18 : 0.3 mm for those with nominal outside diameter not more than 78 mm ; 0.5 mm for those with nominal diameter over 78 mm.
 Bearings belonging to dimension series 19 : 0.3 mm for those with nominal outside diameter not more than 47 mm ; 0.5 mm for those with nominal diameter over 47 mm.

– diameter series 18, 19 –

Unit : mm

No.	Locating snap ring						Shoulder bore dia. D_x
	Section height e		Thickness f		Mounted state		
	max.	min.	max.	min.	Distance between cut ends g	Locating snap ring O.D. D_2	
NR 1022	2.0	1.85	0.7	0.6	2	24.8	25.5
NR 1024	2.0	1.85	0.7	0.6	2	26.8	27.5
NR 1028	2.05	1.9	0.85	0.75	3	30.8	31.5
NR 1030	2.05	1.9	0.85	0.75	3	32.8	33.5
NR 1032	2.05	1.9	0.85	0.75	3	34.8	35.5
NR 1034	2.05	1.9	0.85	0.75	3	36.8	37.5
NR 1037	2.05	1.9	0.85	0.75	3	39.8	40.5
NR 1039	2.05	1.9	0.85	0.75	3	41.8	42.5
NR 1040	2.05	1.9	0.85	0.75	3	42.8	43.5
NR 1042	2.05	1.9	0.85	0.75	3	44.8	45.5
NR 1044	2.05	1.9	0.85	0.75	4	46.8	47.5
NR 1045	2.05	1.9	0.85	0.75	4	47.8	48.5
NR 1047	2.05	1.9	0.85	0.75	4	49.8	50.5
NR 1052	2.05	1.9	0.85	0.75	4	54.8	55.5
NR 1055	2.05	1.9	0.85	0.75	4	57.8	58.5
NR 1058	2.05	1.9	0.85	0.75	4	60.8	61.5
NR 1062	2.05	1.9	0.85	0.75	4	64.8	65.5
NR 1065	2.05	1.9	0.85	0.75	4	67.8	68.5
NR 1068	2.05	1.9	0.85	0.75	5	70.8	72
NR 1072	2.05	1.9	0.85	0.75	5	74.8	76
NR 1078	3.25	3.1	1.12	1.02	5	82.7	84
NR 1080	3.25	3.1	1.12	1.02	5	84.4	86
NR 1085	3.25	3.1	1.12	1.02	5	89.4	91
NR 1090	3.25	3.1	1.12	1.02	5	94.4	96
NR 1095	3.25	3.1	1.12	1.02	5	99.4	101
NR 1100	3.25	3.1	1.12	1.02	5	104.4	106
NR 1105	4.04	3.89	1.12	1.02	5	110.7	112
NR 1110	4.04	3.89	1.12	1.02	5	115.7	117
NR 1115	4.04	3.89	1.12	1.02	5	120.7	122
NR 1120	4.04	3.89	1.12	1.02	7	125.7	127
NR 1125	4.04	3.89	1.12	1.02	7	130.7	132
NR 1130	4.04	3.89	1.12	1.02	7	135.7	137
NR 1140	4.04	3.89	1.7	1.6	7	145.7	147
NR 1145	4.04	3.89	1.7	1.6	7	150.7	152
NR 1150	4.04	3.89	1.7	1.6	7	155.7	157
NR 1165	4.85	4.7	1.7	1.6	7	171.5	173
NR 1175	4.85	4.7	1.7	1.6	10	181.5	183
NR 1180	4.85	4.7	1.7	1.6	10	186.5	188
NR 1190	4.85	4.7	1.7	1.6	10	196.5	198
NR 1200	4.85	4.7	1.7	1.6	10	206.5	208

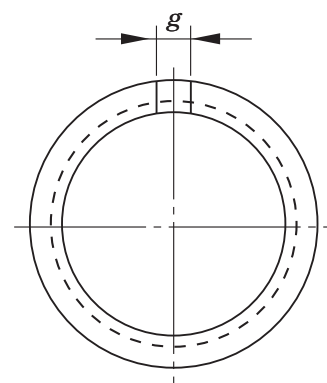
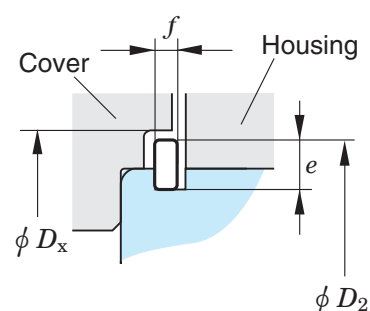
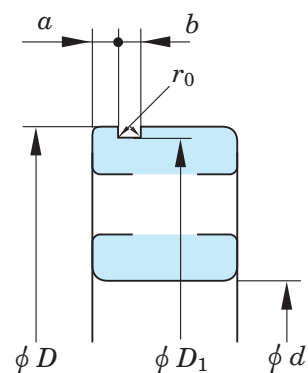

Supplementary table 5 (2) Dimension of snap ring grooves and locating snap rings

Applicable bearing				Snap ring groove									
Bore dia. <i>d</i>				Outside dia. <i>D</i>	Snap ring groove dia. <i>D</i> ₁		Position of snap ring groove <i>a</i>				Snap ring groove width <i>b</i>		Fillet radius of snap ring groove <i>r</i> ₀
							Diameter series						
Diameter series					max.	min.	0		2, 3, 4		max.	min.	max.
0	2	3	4				max.	min.	max.	min.			
–	10	9	8	30	28.17	27.91	–	–	2.06	1.9	1.65	1.35	0.4
15	12	–	9	32	30.15	29.9	2.06	1.9	2.06	1.9	1.65	1.35	0.4
17	15	10	–	35	33.17	32.92	2.06	1.9	2.06	1.9	1.65	1.35	0.4
–	–	12	10	37	34.77	34.52	–	–	2.06	1.9	1.65	1.35	0.4
–	17	–	–	40	38.1	37.85	–	–	2.06	1.9	1.65	1.35	0.4
20	–	15	12	42	39.75	39.5	2.06	1.9	2.06	1.9	1.65	1.35	0.4
22	–	–	–	44	41.75	41.5	2.06	1.9	–	–	1.65	1.35	0.4
25	20	17	–	47	44.6	44.35	2.06	1.9	2.46	2.31	1.65	1.35	0.4
–	22	–	–	50	47.6	47.35	–	–	2.46	2.31	1.65	1.35	0.4
28	25	20	15	52	49.73	49.48	2.06	1.9	2.46	2.31	1.65	1.35	0.4
30	–	–	–	55	52.6	52.35	2.08	1.88	–	–	1.65	1.35	0.4
–	–	22	–	56	53.6	53.35	–	–	2.46	2.31	1.65	1.35	0.4
32	28	–	–	58	55.6	55.35	2.08	1.88	2.46	2.31	1.65	1.35	0.4
35	30	25	17	62	59.61	59.11	2.08	1.88	3.28	3.07	2.2	1.9	0.6
–	32	–	–	65	62.6	62.1	–	–	3.28	3.07	2.2	1.9	0.6
40	–	28	–	68	64.82	64.31	2.49	2.29	3.28	3.07	2.2	1.9	0.6
–	35	30	20	72	68.81	68.3	–	–	3.28	3.07	2.2	1.9	0.6
45	–	32	–	75	71.83	71.32	2.49	2.29	3.28	3.07	2.2	1.9	0.6
50	40	35	25	80	76.81	76.3	2.49	2.29	3.28	3.07	2.2	1.9	0.6
–	45	–	–	85	81.81	81.31	–	–	3.28	3.07	2.2	1.9	0.6
55	50	40	30	90	86.79	86.28	2.87	2.67	3.28	3.07	3	2.7	0.6
60	–	–	–	95	91.82	91.31	2.87	2.67	–	–	3	2.7	0.6
65	55	45	35	100	96.8	96.29	2.87	2.67	3.28	3.07	3	2.7	0.6
70	60	50	40	110	106.81	106.3	2.87	2.67	3.28	3.07	3	2.7	0.6
75	–	–	–	115	111.81	111.3	2.87	2.67	–	–	3	2.7	0.6
–	65	55	45	120	115.21	114.71	–	–	4.06	3.86	3.4	3.1	0.6
80	70	–	–	125	120.22	119.71	2.87	2.67	4.06	3.86	3.4	3.1	0.6
85	75	60	50	130	125.22	124.71	2.87	2.67	4.06	3.86	3.4	3.1	0.6
90	80	65	55	140	135.23	134.72	3.71	3.45	4.9	4.65	3.4	3.1	0.6
95	–	–	–	145	140.23	139.73	3.71	3.45	–	–	3.4	3.1	0.6
100	85	70	60	150	145.24	144.73	3.71	3.45	4.9	4.65	3.4	3.1	0.6
105	90	75	65	160	155.22	154.71	3.71	3.45	4.9	4.65	3.4	3.1	0.6
110	95	80	–	170	163.65	163.14	3.71	3.45	5.69	5.44	3.8	3.5	0.6
120	100	85	70	180	173.66	173.15	3.71	3.45	5.69	5.44	3.8	3.5	0.6
–	105	90	75	190	183.64	183.13	–	–	5.69	5.44	3.8	3.5	0.6
130	110	95	80	200	193.65	193.14	5.69	5.44	5.69	5.44	3.8	3.5	0.6

- [Remark] 1. Snap ring groove dimension does not apply to bearings of dimension series 00, 82 and 83.
 2. The minimum permissible chamfer dimension for snap ring groove-side outer ring is 0.5 mm, except 0.3 mm for bearings belonging to diameter series 0 with nominal outside diameter not more than 35 mm.

– diameter series 0, 2, 3, 4 –

Unit : mm

No.	Locating snap ring					Mounted state		Shoulder bore dia. D_x
	Section height e		Thickness f		Distance between cut ends g	Locating snap ring O.D. D_2		
	max.	min.	max.	min.			max.	max.
NR 30	3.25	3.1	1.12	1.02	3	34.7	35.5	
NR 32	3.25	3.1	1.12	1.02	3	36.7	37.5	
NR 35	3.25	3.1	1.12	1.02	3	39.7	40.5	
NR 37	3.25	3.1	1.12	1.02	3	41.3	42	
NR 40	3.25	3.1	1.12	1.02	3	44.6	45.5	
NR 42	3.25	3.1	1.12	1.02	3	46.3	47	
NR 44	3.25	3.1	1.12	1.02	3	48.3	49	
NR 47	4.04	3.89	1.12	1.02	4	52.7	53.5	
NR 50	4.04	3.89	1.12	1.02	4	55.7	56.5	
NR 52	4.04	3.89	1.12	1.02	4	57.9	58.5	
NR 55	4.04	3.89	1.12	1.02	4	60.7	61.5	
NR 56	4.04	3.89	1.12	1.02	4	61.7	62.5	
NR 58	4.04	3.89	1.12	1.02	4	63.7	64.5	
NR 62	4.04	3.89	1.7	1.6	4	67.7	68.5	
NR 65	4.04	3.89	1.7	1.6	4	70.7	71.5	
NR 68	4.85	4.7	1.7	1.6	5	74.6	76	
NR 72	4.85	4.7	1.7	1.6	5	78.6	80	
NR 75	4.85	4.7	1.7	1.6	5	81.6	83	
NR 80	4.85	4.7	1.7	1.6	5	86.6	88	
NR 85	4.85	4.7	1.7	1.6	5	91.6	93	
NR 90	4.85	4.7	2.46	2.36	5	96.5	98	
NR 95	4.85	4.7	2.46	2.36	5	101.6	103	
NR100	4.85	4.7	2.46	2.36	5	106.5	108	
NR110	4.85	4.7	2.46	2.36	5	116.6	118	
NR115	4.85	4.7	2.46	2.36	5	121.6	123	
NR120	7.21	7.06	2.82	2.72	7	129.7	131.5	
NR125	7.21	7.06	2.82	2.72	7	134.7	136.5	
NR130	7.21	7.06	2.82	2.72	7	139.7	141.5	
NR140	7.21	7.06	2.82	2.72	7	149.7	152	
NR145	7.21	7.06	2.82	2.72	7	154.7	157	
NR150	7.21	7.06	2.82	2.72	7	159.7	162	
NR160	7.21	7.06	2.82	2.72	7	169.7	172	
NR170	9.6	9.45	3.1	3	10	182.9	185	
NR180	9.6	9.45	3.1	3	10	192.9	195	
NR190	9.6	9.45	3.1	3	10	202.9	205	
NR200	9.6	9.45	3.1	3	10	212.9	215	

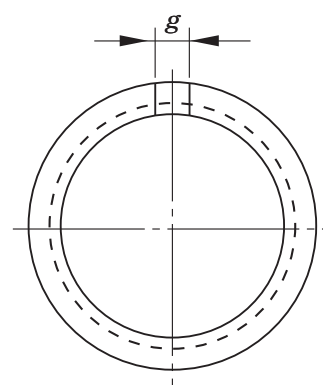
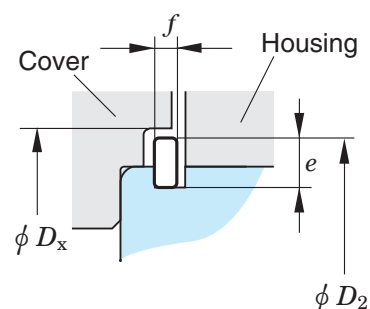
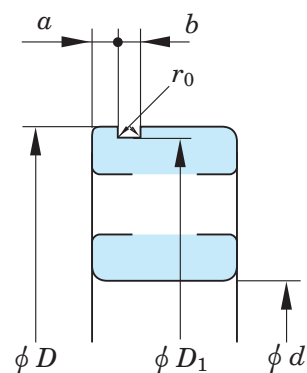

Supplementary table 6 Shaft tolerances (deviation from nominal dimensions)

Nominal shaft dia. (mm)		Deviation classes of shaft dia.															
over	up to	d 6	e 6	f 6	g 5	g 6	h 5	h 6	h 7	h 8	h 9	h 10	js 5	js 6	js 7	j 5	j 6
3	6	-30 -38	-20 -28	-10 -18	-4 -9	-4 -12	-0 -5	-0 -8	0 -12	0 -18	0 -30	0 -48	± 2.5	± 4	± 6	+ 3 - 2	+ 6 - 2
6	10	-40 -49	-25 -34	-13 -22	-5 -11	-5 -14	-0 -6	-0 -9	0 -15	0 -22	0 -36	0 -58	± 3	± 4.5	± 7.5	+ 4 - 2	+ 7 - 2
10	18	-50 -61	-32 -43	-16 -27	-6 -14	-6 -17	-0 -8	0 -11	0 -18	0 -27	0 -43	0 -70	± 4	± 5.5	± 9	+ 5 - 3	+ 8 - 3
18	30	-65 -78	-40 -53	-20 -33	-7 -16	-7 -20	-0 -9	0 -13	0 -21	0 -33	0 -52	0 -84	± 4.5	± 6.5	±10.5	+ 5 - 4	+ 9 - 4
30	50	-80 -96	-50 -66	-25 -41	-9 -20	-9 -25	0 -11	0 -16	0 -25	0 -39	0 -62	0 -100	± 5.5	± 8	±12.5	+ 6 - 5	+11 - 5
50	80	-100 -119	-60 -79	-30 -49	-10 -23	-10 -29	0 -13	0 -19	0 -30	0 -46	0 -74	0 -120	± 6.5	± 9.5	±15	+ 6 - 7	+12 - 7
80	120	-120 -142	-72 -94	-36 -58	-12 -27	-12 -34	0 -15	0 -22	0 -35	0 -54	0 -87	0 -140	± 7.5	±11	±17.5	+ 6 - 9	+13 - 9
120	180	-145 -170	-85 -110	-43 -68	-14 -32	-14 -39	0 -18	0 -25	0 -40	0 -63	0 -100	0 -160	± 9	±12.5	±20	+ 7 -11	+14 -11
180	250	-170 -199	-100 -129	-50 -79	-15 -35	-15 -44	0 -20	0 -29	0 -46	0 -72	0 -115	0 -185	±10	±14.5	±23	+ 7 -13	+16 -13
250	315	-190 -222	-110 -142	-56 -88	-17 -40	-17 -49	0 -23	0 -32	0 -52	0 -81	0 -130	0 -210	±11.5	±16	±26	+ 7 -16	±16
315	400	-210 -246	-125 -161	-62 -98	-18 -43	-18 -54	0 -25	0 -36	0 -57	0 -89	0 -140	0 -230	±12.5	±18	±28.5	+ 7 -18	±18
400	500	-230 -270	-135 -175	-68 -108	-20 -47	-20 -60	0 -27	0 -40	0 -63	0 -97	0 -155	0 -250	±13.5	±20	±31.5	+ 7 -20	±20
500	630	-260 -304	-145 -189	-76 -120	-	-22 -66	-	0 -44	0 -70	0 -110	0 -175	0 -280	-	±22	±35	-	-
630	800	-290 -340	-160 -210	-80 -130	-	-24 -74	-	0 -50	0 -80	0 -125	0 -200	0 -320	-	±25	±40	-	-
800	1000	-320 -376	-170 -226	-86 -142	-	-26 -82	-	0 -56	0 -90	0 -140	0 -230	0 -360	-	±28	±45	-	-

[Note] 1) Δ_{dmp} : single plane mean bore diameter deviation

Unit : μm (Refer.)

												Nominal shaft dia. (mm)		$\Delta_{dmp}^{(1)}$ of bearing (class 0)
k 5	k 6	k 7	m 5	m 6	m 7	n 5	n 6	p 6	r 6	r 7	over	up to		
+ 6 + 1	+ 9 + 1	+13 + 1	+ 9 + 4	+12 + 4	+ 16 + 4	+13 + 8	+ 16 + 8	+ 20 + 12	+ 23 + 15	+ 27 + 15	3	6	0 - 8	
+ 7 + 1	+10 + 1	+16 + 1	+12 + 6	+15 + 6	+ 21 + 6	+16 +10	+ 19 +10	+ 24 + 15	+ 28 + 19	+ 34 + 19	6	10	0 - 8	
+ 9 + 1	+12 + 1	+19 + 1	+15 + 7	+18 + 7	+ 25 + 7	+20 +12	+ 23 +12	+ 29 + 18	+ 34 + 23	+ 41 + 23	10	18	0 - 8	
+11 + 2	+15 + 2	+23 + 2	+17 + 8	+21 + 8	+ 29 + 8	+24 +15	+ 28 +15	+ 35 + 22	+ 41 + 28	+ 49 + 28	18	30	0 - 10	
+13 + 2	+18 + 2	+27 + 2	+20 + 9	+25 + 9	+ 34 + 9	+28 +17	+ 33 +17	+ 42 + 26	+ 50 + 34	+ 59 + 34	30	50	0 - 12	
+15 + 2	+21 + 2	+32 + 2	+24 +11	+30 +11	+ 41 + 11	+33 +20	+ 39 + 20	+ 51 + 32	+ 60 + 41	+ 71 + 41	50	65	0 - 15	
									+ 62 + 43	+ 73 + 43	65	80		
+18 + 3	+25 + 3	+38 + 3	+28 +13	+35 +13	+ 48 + 13	+38 +23	+ 45 + 23	+ 59 + 37	+ 73 + 51	+ 86 + 51	80	100	0 - 20	
									+ 76 + 54	+ 89 + 54	100	120		
+21 + 3	+28 + 3	+43 + 3	+33 +15	+40 +15	+ 55 + 15	+45 +27	+ 52 + 27	+ 68 + 43	+ 88 + 63	+103 + 63	120	140	0 - 25	
									+ 90 + 65	+105 + 65	140	160		
									+ 93 + 68	+108 + 68	160	180		
+24 + 4	+33 + 4	+50 + 4	+37 +17	+46 +17	+ 63 + 17	+51 +31	+ 60 + 31	+ 79 + 50	+106 + 77	+123 + 77	180	200	0 - 30	
									+109 + 80	+126 + 80	200	225		
									+113 + 84	+130 + 84	225	250		
+27 + 4	+36 + 4	+56 + 4	+43 +20	+52 +20	+ 72 + 20	+57 +34	+ 66 + 34	+ 88 + 56	+126 + 94	+146 + 94	250	280	0 - 35	
									+130 + 98	+150 + 98	280	315		
+29 + 4	+40 + 4	+61 + 4	+46 +21	+57 +21	+ 78 + 21	+62 +37	+ 73 + 37	+ 98 + 62	+144 +108	+165 +108	315	355	0 - 40	
									+150 +114	+171 +114	355	400		
+32 + 5	+45 + 5	+68 + 5	+50 +23	+63 +23	+ 86 + 23	+67 +40	+ 80 + 40	+108 + 68	+166 +126	+189 +126	400	450	0 - 45	
									+172 +132	+195 +132	450	500		
									+194 +150	+220 +150	500	560		
-	+44 0	+70 0	-	+70 +26	+ 96 + 26	-	+ 88 + 44	+122 + 78	+199 +155	+225 +155	560	630	0 - 50	
									+225 +175	+255 +175	630	710		
-	+50 0	+80 0	-	+80 +30	+110 + 30	-	+100 + 50	+138 + 88	+235 +185	+265 +185	710	800	0 - 75	
									+266 +210	+300 +210	800	900		
-	+56 0	+90 0	-	+90 +34	+124 + 34	-	+112 + 56	+156 +100	+276 +220	+310 +220	900	1000	0 -100	

Supplementary table 7 Housing bore tolerances (deviation from nominal dimensions)

Nominal Bore dia. (mm)		Deviation classes of housing bore														
over	up to	E 6	F 6	F 7	G 6	G 7	H 6	H 7	H 8	H 9	H 10	JS 5	JS 6	JS 7	J 6	J 7
10	18	+ 43 + 32	+ 27 + 16	+ 34 + 16	+17 + 6	+ 24 + 6	+11 0	+ 18 0	+ 27 0	+ 43 0	+ 70 0	± 4	± 5.5	± 9	+ 6 - 5	+10 - 8
18	30	+ 53 + 40	+ 33 + 20	+ 41 + 20	+20 + 7	+ 28 + 7	+13 0	+ 21 0	+ 33 0	+ 52 0	+ 84 0	± 4.5	± 6.5	±10.5	+ 8 - 5	+12 - 9
30	50	+ 66 + 50	+ 41 + 25	+ 50 + 25	+25 + 9	+ 34 + 9	+16 0	+ 25 0	+ 39 0	+ 62 0	+100 0	± 5.5	± 8	±12.5	+10 - 6	+14 -11
50	80	+ 79 + 60	+ 49 + 30	+ 60 + 30	+29 +10	+ 40 + 10	+19 0	+ 30 0	+ 46 0	+ 74 0	+120 0	± 6.5	± 9.5	±15	+13 - 6	+18 -12
80	120	+ 94 + 72	+ 58 + 36	+ 71 + 36	+34 +12	+ 47 + 12	+22 0	+ 35 0	+ 54 0	+ 87 0	+140 0	± 7.5	±11	±17.5	+16 - 6	+22 -13
120	180	+110 + 85	+ 68 + 43	+ 83 + 43	+39 +14	+ 54 + 14	+25 0	+ 40 0	+ 63 0	+100 0	+160 0	± 9	±12.5	±20	+18 - 7	+26 -14
180	250	+129 +100	+ 79 + 50	+ 96 + 50	+44 +15	+ 61 + 15	+29 0	+ 46 0	+ 72 0	+115 0	+185 0	±10	±14.5	±23	+22 - 7	+30 -16
250	315	+142 +110	+ 88 + 56	+108 + 56	+49 +17	+ 69 + 17	+32 0	+ 52 0	+ 81 0	+130 0	+210 0	±11.5	±16	±26	+25 - 7	+36 -16
315	400	+161 +125	+ 98 + 62	+119 + 62	+54 +18	+ 75 + 18	+36 0	+ 57 0	+ 89 0	+140 0	+230 0	±12.5	±18	±28.5	+29 - 7	+39 -18
400	500	+175 +135	+108 + 68	+131 + 68	+60 +20	+ 83 + 20	+40 0	+ 63 0	+ 97 0	+155 0	+250 0	±13.5	±20	±31.5	+33 - 7	+43 -20
500	630	+189 +145	+120 + 76	+146 + 76	+66 +22	+ 92 + 22	+44 0	+ 70 0	+110 0	+175 0	+280 0	-	±22	±35	-	-
630	800	+210 +160	+130 + 80	+160 + 80	+74 +24	+104 + 24	+50 0	+ 80 0	+125 0	+200 0	+320 0	-	±25	±40	-	-
800	1000	+226 +170	+142 + 86	+176 + 86	+82 +26	+116 + 26	+56 0	+ 90 0	+140 0	+230 0	+360 0	-	±28	±45	-	-
1000	1250	+261 +195	+164 + 98	+203 + 98	+94 +28	+133 + 28	+66 0	+105 0	+165 0	+260 0	+420 0	-	±33	±52.5	-	-

[Note] 1) Δ_{Dmp} : single plane mean outside diameter deviation

Unit : μm (Refer.)

													Nominal Bore dia. (mm)		$\Delta_{Dmp}^{(1)}$ of bearing (class 0)
K 5	K 6	K 7	M 5	M 6	M 7	N 5	N 6	N 7	P 6	P 7	R 7	over	up to		
+ 2 - 6	+ 2 - 9	+ 6 - 12	- 4 - 12	- 4 - 15	0 - 18	- 9 - 17	- 9 - 20	- 5 - 23	- 15 - 26	- 11 - 29	- 16 - 34	10	18	0 - 8	
+ 1 - 8	+ 2 - 11	+ 6 - 15	- 5 - 14	- 4 - 17	0 - 21	- 12 - 21	- 11 - 24	- 7 - 28	- 18 - 31	- 14 - 35	- 20 - 41	18	30	0 - 9	
+ 2 - 9	+ 3 - 13	+ 7 - 18	- 5 - 16	- 4 - 20	0 - 25	- 13 - 24	- 12 - 28	- 8 - 33	- 21 - 37	- 17 - 42	- 25 - 50	30	50	0 - 11	
+ 3 - 10	+ 4 - 15	+ 9 - 21	- 6 - 19	- 5 - 24	0 - 30	- 15 - 28	- 14 - 33	- 9 - 39	- 26 - 45	- 21 - 51	- 30 - 60	50	65	0 - 13	
											- 32 - 62	65	80		
+ 2 - 13	+ 4 - 18	+ 10 - 25	- 8 - 23	- 6 - 28	0 - 35	- 18 - 33	- 16 - 38	- 10 - 45	- 30 - 52	- 24 - 59	- 38 - 73	80	100	0 - 15	
											- 41 - 76	100	120		
+ 3 - 15	+ 4 - 21	+ 12 - 28	- 9 - 27	- 8 - 33	0 - 40	- 21 - 39	- 20 - 45	- 12 - 52	- 36 - 61	- 28 - 68	- 48 - 88	120	140	(up to 150) 0 - 18 (over to 150) 0 - 25	
											- 50 - 90	140	160		
											- 53 - 93	160	180		
+ 2 - 18	+ 5 - 24	+ 13 - 33	- 11 - 31	- 8 - 37	0 - 46	- 25 - 45	- 22 - 51	- 14 - 60	- 41 - 70	- 33 - 79	- 60 - 106	180	200	0 - 30	
											- 63 - 109	200	225		
											- 67 - 113	225	250		
+ 3 - 20	+ 5 - 27	+ 16 - 36	- 13 - 36	- 9 - 41	0 - 52	- 27 - 50	- 25 - 57	- 14 - 66	- 47 - 79	- 36 - 88	- 74 - 126	250	280	0 - 35	
											- 78 - 130	280	315		
+ 3 - 22	+ 7 - 29	+ 17 - 40	- 14 - 39	- 10 - 46	0 - 57	- 30 - 55	- 26 - 62	- 16 - 73	- 51 - 87	- 41 - 98	- 87 - 144	315	355	0 - 40	
											- 93 - 150	355	400		
+ 2 - 25	+ 8 - 32	+ 18 - 45	- 16 - 43	- 10 - 50	0 - 63	- 33 - 60	- 27 - 67	- 17 - 80	- 55 - 95	- 45 - 108	- 103 - 166	400	450	0 - 45	
											- 109 - 172	450	500		
-	0 - 44	0 - 70	-	- 26 - 70	- 26 - 96	-	- 44 - 88	- 44 - 114	- 78 - 122	- 78 - 148	- 150 - 220	500	560	0 - 50	
											- 155 - 225	560	630		
-	0 - 50	0 - 80	-	- 30 - 80	- 30 - 110	-	- 50 - 100	- 50 - 130	- 88 - 138	- 88 - 168	- 175 - 255	630	710	0 - 75	
											- 185 - 265	710	800		
-	0 - 56	0 - 90	-	- 34 - 90	- 34 - 124	-	- 56 - 112	- 56 - 146	- 100 - 156	- 100 - 190	- 210 - 300	800	900	0 - 100	
											- 220 - 310	900	1000		
-	0 - 66	0 - 105	-	- 40 - 106	- 40 - 145	-	- 66 - 132	- 66 - 171	- 120 - 186	- 120 - 225	- 250 - 355	1000	1120	0 - 125	
											- 260 - 365	1120	1250		

Supplementary table 8 Numerical values for standard tolerance grades IT (ISO 286-1 : 1988)

Basic size (mm)		Standard tolerance grades (IT)																	
		1	2	3	4	5	6	7	8	9	10	11	12	13	14 ¹⁾	15 ¹⁾	16 ¹⁾	17 ¹⁾	18 ¹⁾
over	up to	Tolerances (μm)											Tolerances (mm)						
–	3	0.8	1.2	2	3	4	6	10	14	25	40	60	0.10	0.14	0.26	0.40	0.60	1.00	1.40
3	6	1	1.5	2.5	4	5	8	12	18	30	48	75	0.12	0.18	0.30	0.48	0.75	1.20	1.80
6	10	1	1.5	2.5	4	6	9	15	22	36	58	90	0.15	0.22	0.36	0.58	0.90	1.50	2.20
10	18	1.2	2	3	5	8	11	18	27	43	70	110	0.18	0.27	0.43	0.70	1.10	1.80	2.70
18	30	1.5	2.5	4	6	9	13	21	33	52	84	130	0.21	0.33	0.52	0.84	1.30	2.10	3.30
30	50	1.5	2.5	4	7	11	16	25	39	62	100	160	0.25	0.39	0.62	1.00	1.60	2.50	3.90
50	80	2	3	5	8	13	19	30	46	74	120	190	0.30	0.46	0.74	1.20	1.90	3.00	4.60
80	120	2.5	4	6	10	15	22	35	54	87	140	220	0.35	0.54	0.87	1.40	2.20	3.50	5.40
120	180	3.5	5	8	12	18	25	40	63	100	160	250	0.40	0.63	1.00	1.60	2.50	4.00	6.30
180	250	4.5	7	10	14	20	29	46	72	115	185	290	0.46	0.72	1.15	1.85	2.90	4.60	7.20
250	315	6	8	12	16	23	32	52	81	130	210	320	0.52	0.81	1.30	2.10	3.20	5.20	8.10
315	400	7	9	13	18	25	36	57	89	140	230	360	0.57	0.89	1.40	2.30	3.60	5.70	8.90
400	500	8	10	15	20	27	40	63	97	155	250	400	0.63	0.97	1.55	2.50	4.00	6.30	9.70
500	630	–	–	–	–	–	44	70	110	175	280	440	0.70	1.10	1.75	2.80	4.40	7.00	11.00
630	800	–	–	–	–	–	50	80	125	200	320	500	0.80	1.25	2.00	3.20	5.00	8.00	12.50
800	1000	–	–	–	–	–	56	90	140	230	360	560	0.90	1.40	2.30	3.60	5.60	9.00	14.00
1000	1250	–	–	–	–	–	66	105	165	260	420	660	1.05	1.65	2.60	4.20	6.60	10.50	16.50
1250	1600	–	–	–	–	–	78	125	195	310	500	780	1.25	1.95	3.10	5.00	7.80	12.50	19.50
1600	2000	–	–	–	–	–	92	150	230	370	600	920	1.50	2.30	3.70	6.00	9.20	15.00	23.00
2000	2500	–	–	–	–	–	110	175	280	440	700	1100	1.75	2.80	4.40	7.00	11.00	17.50	28.00
2500	3150	–	–	–	–	–	135	210	330	540	860	1350	2.10	3.30	5.40	8.60	13.50	21.00	33.00

[Note] 1) Standard tolerance grades IT 14 to IT 18 (incl.) shall not be used for basic sizes less than or equal to 1 mm.

Supplementary table 9 Greek alphabet list

Name	Roman type	Italic type		Name	Roman type	Italic type	
	Capital	Capital	Lowercase		Capital	Capital	Lowercase
alpha	A	<i>A</i>	α	nu	N	<i>N</i>	ν
beta	B	<i>B</i>	β	xi	Ξ	<i>Ξ</i>	ξ
gamma	Γ	<i>Γ</i>	γ	omicron	O	<i>O</i>	o
delta	Δ	<i>Δ</i>	δ	pi	Π	<i>Π</i>	π
epsilon	E	<i>E</i>	ϵ	rho	P	<i>P</i>	ρ
zeta	Z	<i>Z</i>	ζ	sigma	Σ	<i>Σ</i>	σ
eta	H	<i>H</i>	η	tau	T	<i>T</i>	τ
theta	Θ	<i>Θ</i>	θ	upsilon	Y	<i>Y</i>	υ
iota	I	<i>I</i>	ι	phi	Φ	<i>Φ</i>	ϕ
kappa	K	<i>K</i>	κ	chi	X	<i>X</i>	χ
lambda	Λ	<i>Λ</i>	λ	psi	Ψ	<i>Ψ</i>	ψ
mu	M	<i>M</i>	μ	omega	Ω	<i>Ω</i>	ω

Supplementary table 10 Prefixes used with SI units

Factor	Prefix		Factor	Prefix	
	Name	Symbol		Name	Symbol
10^{18}	exa	E	10^{-1}	deci	d
10^{15}	peta	P	10^{-2}	centi	c
10^{12}	tera	T	10^{-3}	milli	m
10^9	giga	G	10^{-6}	micro	μ
10^6	mega	M	10^{-9}	nano	n
10^3	kilo	k	10^{-12}	pico	p
10^2	hecto	h	10^{-15}	femto	f
10	deka	da	10^{-18}	atto	a

Supplementary table 11 (1) SI units and conversion factors

Mass	SI units	Other units ¹⁾	Conversion into SI units	Conversion from SI units
Angle	rad [radian(s)]	° [degree(s)] * ' [minute(s)] * " [second(s)] *	1° = π /180 rad 1' = π /10 800 rad 1" = π /648 000 rad	1 rad = 57.295 78°
Length	m [meter(s)]	Å [Angstrom unit] μ [micron(s)] in [inch(es)] ft [foot(feet)] yd [yard(s)] mile [mile(s)]	1Å = 10 ⁻¹⁰ m = 0.1nm = 100pm 1μ = 1 μm 1in = 25.4 mm 1ft = 12 in = 0.304 8 m 1yd = 3 ft = 0.914 4 m 1mile = 5 280 ft = 1 609.344 m	1m = 10 ¹⁰ Å 1m = 39.37 in 1m = 3.280 8 ft 1m = 1.093 6 yd 1km = 0.621 4 mile
Area	m ²	a [are(s)] ha [hectare(s)] acre [acre(s)]	1a = 100 m ² 1ha = 10 ⁴ m ² 1acre = 4 840 yd ² = 4 046.86 m ²	1km ² = 247.1 acre
Volume	m ³	ℓ , L [liter(s)] * cc [cubic centimeters] gal(US) [gallon(s)] floz(US) [fluid ounce(s)] barrel(US) [barrels(US)]	1 ℓ = 1 dm ³ = 10 ⁻³ m ³ 1cc = 1 cm ³ = 10 ⁻⁶ m ³ 1gal(US) = 231 in ³ = 3.785 41dm ³ 1floz(US) = 29.573 5 cm ³ 1barrel(US) = 158.987 dm ³	1m ³ = 10 ³ ℓ 1m ³ = 10 ⁶ cc 1m ³ = 264.17 gal 1m ³ = 33 814 floz 1m ³ = 6.289 8 barrel
Time	s [second(s)]	min [minute(s)] * h [hour(s)] * d [day(s)] *		
Angular velocity	rad/s			
Velocity	m/s	kn [knot(s)] * m/h	1kn = 1 852 m/h	1km/h = 0.539 96 kn
Acceleration	m/s ²	G	1G = 9.806 65 m/s ²	1m/s ² = 0.101 97 G
Frequency	Hz [hertz]	c/s [cycle(s)/second]	1c/s = 1s ⁻¹ = 1 Hz	
Rotational frequency	s ⁻¹	rpm [revolutions per minute] * min ⁻¹ r/min	1rpm = 1 / 60 s ⁻¹	1s ⁻¹ = 60 rpm
Mass	kg [kilogram(s)]	t [ton(s)] * lb [pound(s)] gr [grain(s)] oz [ounce(s)] ton (UK) [ton(s)(UK)] ton (US) [ton(s)(US)] car [carat(s)]	1t = 10 ³ kg 1lb = 0.453 592 37 kg 1gr = 64.798 91 mg 1oz = 1/16 lb = 28.349 5 g 1ton(UK) = 1 016.05 kg 1ton(US) = 907.185 kg 1car = 200 mg	1kg = 2.204 6 lb 1g = 15.432 4 gr 1kg = 35.274 0 oz 1t = 0.984 2 ton(UK) 1t = 1.102 3 ton(US) 1g = 5 car

[Note] * : Unit can be used as an SI unit.

No asterisk : Unit cannot be used.

Supplementary table 11 (2) SI units and conversion factors

Mass	SI units	Other units ¹⁾	Conversion into SI units	Conversion from SI units
Density	kg/m ³			
Linear density	kg/m			
Momentum	kg·m/s			
Moment of momentum, angular momentum	} kg·m ² /s			
Moment of inertia		kg·m ²		
Force	N [newton(s)]	dyn [dyne(s)] kgf [kilogram-force] gf [gram-force] tf [ton-force] lbf [pound-force]	1dyn = 10 ⁻⁵ N 1kgf = 9.806 65 N 1gf = 9.806 65×10 ⁻³ N 1tf = 9.806 65×10 ³ N 1lbf = 4.448 22 N	1N = 10 ⁵ dyn 1N = 0.101 97 kgf 1N = 0.224 809 lbf
Moment of force	N·m [Newton meter(s)]	gf·cm kgf·cm kgf·m tf·m lbf·ft	1gf·cm = 9.806 65×10 ⁻⁵ N·m 1kgf·cm = 9.806 65×10 ⁻² N·m 1kgf·m = 9.806 65 N·m 1tf·m = 9.806 65×10 ³ N·m 1lbf·ft = 1.355 82 N·m	1N·m = 0.101 97 kgf·m 1N·m = 0.737 56 lbf·ft
Pressure, Normal stress	Pa [Pascal(s)] or N/m ² { 1 Pa = 1 N/m ² }	gf/cm ² kgf/mm ² kgf/m ² lbf/in ² bar [bar(s)] at [engineering air pressure] mH ₂ O, mAq [meter water column] atm [atmosphere] mHg [meter mercury column] Torr [torr]	1gf/cm ² = 9.806 65×10 Pa 1kgf/mm ² = 9.806 65×10 ⁶ Pa 1kgf/m ² = 9.806 65 Pa 1lbf/in ² = 6 894.76 Pa 1bar = 10 ⁵ Pa 1at = 1kgf/cm ² = 9.806 65×10 ⁴ Pa 1mH ₂ O = 9.806 65×10 ³ Pa 1atm = 101 325 Pa 1mHg = $\frac{101\ 325}{0.76}$ Pa 1Torr = 1 mmHg = 133.322 Pa	1MPa = 0.101 97 kgf/mm ² 1Pa = 0.101 97 kgf/m ² 1Pa = 0.145×10 ⁻³ lbf/in ² 1Pa = 10 ⁻² mbar 1Pa = 7.500 6×10 ⁻³ Torr
Viscosity	Pa·s [pascal second]	P [poise] kgf·s/m ²	10 ⁻² P = 1 cP = 1 mPa·s 1kgf·s/m ² = 9.806 65 Pa·s	1Pa·s = 0.101 97 kgf·s/m ²
Kinematic viscosity	m ² /s	St [stokes]	10 ⁻² St = 1 cSt = 1 mm ² /s	
Surface tension	N/m			

Supplementary table 11 (3) SI units and conversion factors

Mass	SI units	Other units ¹⁾	Conversion into SI units	Conversion from SI units
Work, energy	J [joule(s)] {1 J=1 N·m}	eV [electron volt(s)] * erg [erg(s)] kgf·m lbf·ft	1eV = (1.602 189 2± 0.000 004 6)×10 ⁻¹⁹ J 1 erg = 10 ⁻⁷ J 1 kgf·m = 9.806 65 J 1 lbf·ft = 1.355 82 J	1 J = 10 ⁷ erg 1 J = 0.101 97 kgf·m 1 J = 0.737 56 lbf·ft
Power	W [watt(s)]	erg/s [ergs per second] kgf·m/s PS [French horse-power] HP [horse-power (British)] lbf·ft/s	1 erg/s = 10 ⁻⁷ W 1 kgf·m/s = 9.806 65 W 1 PS = 75 kgf·m/s = 735.5 W 1 HP = 550 lbf·ft/s = 745.7 W 1 lbf·ft/s = 1.355 82 W	1 W = 0.101 97 kgf·m/s 1 W = 0.001 36 PS 1 W = 0.001 34 HP
Thermo-dynamic temperature	K [kelvin(s)]			
Celsius temperature	°C [Celsius(s)] {t°C = (t+273.15)K}	°F [degree(s) Fahrenheit]	t °F = $\frac{5}{9}(t-32)°C$	t °C = $(\frac{9}{5}t+32)°F$
Linear expansion coefficient	K ⁻¹	°C ⁻¹ [per degree]		
Heat	J [joule(s)] {1 J=1 N·m}	erg [erg(s)] kgf·m cal _{IT} [l. T. calories]	1 erg = 10 ⁻⁷ J 1 cal _{IT} = 4.186 8 J 1 Mcal _{IT} = 1.163 kW·h	1 J = 10 ⁷ erg 1 J = 0.238 85 cal _{IT} 1 kW·h = 0.86 × 10 ⁶ cal _{IT}
Thermal conductivity	W/(m·K)	W/(m·°C) cal/(s·m·°C)	1 W/(m·°C) = 1 W/(m·K) 1 cal/(s·m·°C) = 4.186 05 W/(m·K)	
Coefficient of heat transfer	W/(m ² ·K)	W/(m ² ·°C) cal/(s·m ² ·°C)	1 W/(m ² ·°C) = 1 W/(m ² ·K) 1 cal/(s·m ² ·°C) = 4.186 05 W/(m ² ·K)	
Heat capacity	J/K	J/°C	1 J/°C = 1 J/K	
Massic heat capacity	J/(kg·K)	J/(kg·°C)		

[Note] * : Unit can be used as an SI unit.
No asterisk : Unit cannot be used.

Supplementary table 11 (4) SI units and conversion factors

Mass	SI units	Other units ¹⁾	Conversion into SI units	Conversion from SI units
Electric current	A [ampere(s)]			
Electric charge, quantity of electricity	C [coulomb(s)] { 1 C = 1 A·s }	A·h	* 1 A·h = 3.6 kC	
Tension, electric potential	V [volt(s)] { 1 V = 1 W/A }			
Capacitance	F [farad(s)] { 1 F = 1 C/V }			
Magnetic field strength	A/m	Oe [oersted(s)]	$1 \text{ Oe} = \frac{10^3}{4\pi} \text{ A/m}$	$1 \text{ A/m} = 4\pi \times 10^{-3} \text{ Oe}$
Magnetic flux density	T [tesla(s)] { $1\text{T}=1\text{N} / (\text{A}\cdot\text{m})$ $=1\text{Wb} / \text{m}^2$ $=1\text{V}\cdot\text{s} / \text{m}^2$ }	Gs [gauss(es)] γ [gamma(s)]	$1 \text{ Gs} = 10^{-4} \text{ T}$ $1 \gamma = 10^{-9} \text{ T}$	$1 \text{ T} = 10^4 \text{ Gs}$ $1 \text{ T} = 10^9 \gamma$
Magnetic flux	Wb [weber(s)] { 1 Wb = 1 V·s }	Mx [maxwell(s)]	$1 \text{ Mx} = 10^{-8} \text{ Wb}$	$1 \text{ Wb} = 10^8 \text{ Mx}$
Self inductance	H [henry(-ries)] { 1 H = 1 Wb/A }			
Resistance (to direct current)	Ω [ohm(s)] { 1 Ω = 1 V/A }			
Conductance (to direct current)	S [siemens] { 1 S = 1 A/V }			
Active power	W { $1 \text{ W}=1 \text{ J/s}$ $=1 \text{ A}\cdot\text{V}$ }			

Supplementary table 12 Inch/millimeter conversion

Inch		Inches										
		0	1	2	3	4	5	6	7	8	9	10
		mm										
0	0	0	25.4000	50.8000	76.2000	101.6000	127.0000	152.4000	177.8000	203.2000	228.6000	254.0000
1/64	0.015625	0.3969	25.7969	51.1969	76.5969	101.9969	127.3969	152.7969	178.1969	203.5969	228.9969	254.3969
1/32	0.03125	0.7938	26.1938	51.5938	76.9938	102.3938	127.7938	153.1938	178.5938	203.9938	229.3938	254.7938
3/64	0.046875	1.1906	26.5906	51.9906	77.3906	102.7906	128.1906	153.5906	178.9906	204.3906	229.7906	255.1906
1/16	0.0625	1.5875	26.9875	52.3875	77.7875	103.1875	128.5875	153.9875	179.3875	204.7875	230.1875	255.5875
5/64	0.078125	1.9844	27.3844	52.7844	78.1844	103.5844	128.9844	154.3844	179.7844	205.1844	230.5844	255.9844
3/32	0.09375	2.3812	27.7812	53.1812	78.5812	103.9812	129.3812	154.7812	180.1812	205.5812	230.9812	256.3812
7/64	0.109375	2.7781	28.1781	53.5781	78.9781	104.3781	129.7781	155.1781	180.5781	205.9781	231.3781	256.7781
1/8	0.125	3.1750	28.5750	53.9750	79.3750	104.7750	130.1750	155.5750	180.9750	206.3750	231.7750	257.1750
9/64	0.140625	3.5719	28.9719	54.3719	79.7719	105.1719	130.5719	155.9719	181.3719	206.7719	232.1719	257.5719
5/32	0.15625	3.9688	29.3688	54.7688	80.1688	105.5688	130.9688	156.3688	181.7688	207.1688	232.5688	257.9688
11/64	0.171875	4.3656	29.7656	55.1656	80.5656	105.9656	131.3656	156.7656	182.1656	207.5656	232.9656	258.3656
3/16	0.1875	4.7625	30.1625	55.5625	80.9625	106.3625	131.7625	157.1625	182.5625	207.9625	233.3625	258.7625
13/64	0.203125	5.1594	30.5594	55.9594	81.3594	106.7594	132.1594	157.5594	182.9594	208.3594	233.7594	259.1594
7/32	0.21875	5.5562	30.9562	56.3562	81.7562	107.1562	132.5562	157.9562	183.3562	208.7562	234.1562	259.5562
15/64	0.234375	5.9531	31.3531	56.7531	82.1531	107.5531	132.9531	158.3531	183.7531	209.1531	234.5531	259.9531
1/4	0.25	6.3500	31.7500	57.1500	82.5500	107.9500	133.3500	158.7500	184.1500	209.5500	234.9500	260.3500
17/64	0.265625	6.7469	32.1469	57.5469	82.9469	108.3469	133.7469	159.1469	184.5469	209.9469	235.3469	260.7469
9/32	0.28125	7.1438	32.5438	57.9438	83.3438	108.7438	134.1438	159.5438	184.9438	210.3438	235.7438	261.1438
19/64	0.296875	7.5406	32.9406	58.3406	83.7406	109.1406	134.5406	159.9406	185.3406	210.7406	236.1406	261.5406
5/16	0.3125	7.9375	33.3375	58.7375	84.1375	109.5375	134.9375	160.3375	185.7375	211.1375	236.5375	261.9375
21/64	0.328125	8.3344	33.7344	59.1344	84.5344	109.9344	135.3344	160.7344	186.1344	211.5344	236.9344	262.3344
11/32	0.34375	8.7312	34.1312	59.5312	84.9312	110.3312	135.7312	161.1312	186.5312	211.9312	237.3312	262.7312
23/64	0.359375	9.1281	34.5281	59.9281	85.3281	110.7281	136.1281	161.5281	186.9281	212.3281	237.7281	263.1281
3/8	0.375	9.5250	34.9250	60.3250	85.7250	111.1250	136.5250	161.9250	187.3250	212.7250	238.1250	263.5250
25/64	0.390625	9.9219	35.3219	60.7219	86.1219	111.5219	136.9219	162.3219	187.7219	213.1219	238.5219	263.9219
13/32	0.40625	10.3188	35.7188	61.1188	86.5188	111.9188	137.3188	162.7188	188.1188	213.5188	238.9188	264.3188
27/64	0.421875	10.7156	36.1156	61.5156	86.9156	112.3156	137.7156	163.1156	188.5156	213.9156	239.3156	264.7156
7/16	0.4375	11.1125	36.5125	61.9125	87.3125	112.7125	138.1125	163.5125	188.9125	214.3125	239.7125	265.1125
29/64	0.453125	11.5094	36.9094	62.3094	87.7094	113.1094	138.5094	163.9094	189.3094	214.7094	240.1094	265.5094
15/32	0.46875	11.9062	37.3062	62.7062	88.1062	113.5062	138.9062	164.3062	189.7062	215.1062	240.5062	265.9062
31/64	0.484375	12.3031	37.7031	63.1031	88.5031	113.9031	139.3031	164.7031	190.1031	215.5031	240.9031	266.3031
1/2	0.5	12.7000	38.1000	63.5000	88.9000	114.3000	139.7000	165.1000	190.5000	215.9000	241.3000	266.7000
33/64	0.515625	13.0969	38.4969	63.8969	89.2969	114.6969	140.0969	165.4969	190.8969	216.2969	241.6969	267.0969
17/32	0.53125	13.4938	38.8938	64.2938	89.6938	115.0938	140.4938	165.8938	191.2938	216.6938	242.0938	267.4938
35/64	0.546875	13.8906	39.2906	64.6906	90.0906	115.4906	140.8906	166.2906	191.6906	217.0906	242.4906	267.8906
9/16	0.5625	14.2875	39.6875	65.0875	90.4875	115.8875	141.2875	166.6875	192.0875	217.4875	242.8875	268.2875
37/64	0.578125	14.6844	40.0844	65.4844	90.8844	116.2844	141.6844	167.0844	192.4844	217.8844	243.2844	268.6844
19/32	0.59375	15.0812	40.4812	65.8812	91.2812	116.6812	142.0812	167.4812	192.8812	218.2812	243.6812	269.0812
39/64	0.609375	15.4781	40.8781	66.2781	91.6781	117.0781	142.4781	167.8781	193.2781	218.6781	244.0781	269.4781
5/8	0.625	15.8750	41.2750	66.6750	92.0750	117.4750	142.8750	168.2750	193.6750	219.0750	244.4750	269.8750
41/64	0.640625	16.2719	41.6719	67.0719	92.4719	117.8719	143.2719	168.6719	194.0719	219.4719	244.8719	270.2719
21/32	0.65625	16.6688	42.0688	67.4688	92.8688	118.2688	143.6688	169.0688	194.4688	219.8688	245.2688	270.6688
43/64	0.671875	17.0656	42.4656	67.8656	93.2656	118.6656	144.0656	169.4656	194.8656	220.2656	245.6656	271.0656
11/16	0.6875	17.4625	42.8625	68.2625	93.6625	119.0625	144.4625	169.8625	195.2625	220.6625	246.0625	271.4625
45/64	0.703125	17.8594	43.2594	68.6594	94.0594	119.4594	144.8594	170.2594	195.6594	221.0594	246.4594	271.8594
23/32	0.71875	18.2562	43.6562	69.0562	94.4562	119.8562	145.2562	170.6562	196.0562	221.4562	246.8562	272.2562
47/64	0.734375	18.6531	44.0531	69.4531	94.8531	120.2531	145.6531	171.0531	196.4531	221.8531	247.2531	272.6531
3/4	0.75	19.0500	44.4500	69.8500	95.2500	120.6500	146.0500	171.4500	196.8500	222.2500	247.6500	273.0500
49/64	0.765625	19.4469	44.8469	70.2469	95.6469	121.0469	146.4469	171.8469	197.2469	222.6469	248.0469	273.4469
25/32	0.78125	19.8438	45.2438	70.6438	96.0438	121.4438	146.8438	172.2438	197.6438	223.0438	248.4438	273.8438
51/64	0.796875	20.2406	45.6406	71.0406	96.4406	121.8406	147.2406	172.6406	198.0406	223.4406	248.8406	274.2406
13/16	0.8125	20.6375	46.0375	71.4375	96.8375	122.2375	147.6375	173.0375	198.4375	223.8375	249.2375	274.6375
53/64	0.828125	21.0344	46.4344	71.8344	97.2344	122.6344	148.0344	173.4344	198.8344	224.2344	249.6344	275.0344
27/32	0.84375	21.4312	46.8312	72.2312	97.6312	123.0312	148.4312	173.8312	199.2312	224.6312	250.0312	275.4312
55/64	0.859375	21.8281	47.2281	72.6281	98.0281	123.4281	148.8281	174.2281	199.6281	225.0281	250.4281	275.8281
7/8	0.875	22.2250	47.6250	73.0250	98.4250	123.8250	149.2250	174.6250	200.0250	225.4250	250.8250	276.2250
57/64	0.890625	22.6219	48.0219	73.4219	98.8219	124.2219	149.6219	175.0219	200.4219	225.8219	251.2219	276.6219
29/32	0.90625	23.0188	48.4188	73.8188	99.2188	124.6188	150.0188	175.4188	200.8188	226.2188	251.6188	277.0188
59/64	0.921875	23.4156	48.8156	74.2156	99.6156	125.0156	150.4156	175.8156	201.2156	226.6156	252.0156	277.4156
15/16	0.9375	23.8125	49.2125	74.6125	100.0125	125.4125	150.8125	176.2125	201.6125	227.0125	252.4125	277.8125
61/64	0.953125	24.2094	49.6094	75.0094	100.4094	125.8094	151.2094	176.6094	202.0094	227.4094	252.8094	278.2094
31/32	0.96875	24.6062	50.0062	75.4062	100.8062	126.2062	151.6062	177.0062	202.4062	227.8062	253.2062	278.6062
63/64	0.984375	25.0031	50.4031	75.8031	101.2031	126.6031	152.0031	177.4031	202.8031	228.2031	253.6031	279.0031

Supplementary table 13 Steel hardness conversion

Rockwell C-scale 1 471.0 N	Vicker's	Brinell		Rockwell		Shore
		Standard ball	Tungsten carbide ball	A-scale 588.4 N	B-scale 980.7 N	
68	940			85.6		97
67	900			85.0		95
66	865			84.5		92
65	832		739	83.9		91
64	800		722	83.4		88
63	772		705	82.8		87
62	746		688	82.3		85
61	720		670	81.8		83
60	697		654	81.2		81
59	674		634	80.7		80
58	653		615	80.1		78
57	633		595	79.6		76
56	613		577	79.0		75
55	595	–	560	78.5		74
54	577	–	543	78.0		72
53	560	–	525	77.4		71
52	544	500	512	76.8		69
51	528	487	496	76.3		68
50	513	475	481	75.9		67
49	498	464	469	75.2		66
48	484	451	455	74.7		64
47	471	442	443	74.1		63
46	458	432	432	73.6		62
45	446		421	73.1		60
44	434		409	72.5		58
43	423		400	72.0		57
42	412		390	71.5		56
41	402		381	70.9		55
40	392		371	70.4	–	54
39	382		362	69.9	–	52
38	372		353	69.4	–	51
37	363		344	68.9	–	50
36	354		336	68.4	(109.0)	49
35	345		327	67.9	(108.5)	48
34	336		319	67.4	(108.0)	47
33	327		311	66.8	(107.5)	46
32	318		301	66.3	(107.0)	44
31	310		294	65.8	(106.0)	43
30	302		286	65.3	(105.5)	42
29	294		279	64.7	(104.5)	41
28	286		271	64.3	(104.0)	41
27	279		264	63.8	(103.0)	40
26	272		258	63.3	(102.5)	38
25	266		253	62.8	(101.5)	38
24	260		247	62.4	(101.0)	37
23	254		243	62.0	100.0	36
22	248		237	61.5	99.0	35
21	243		231	61.0	98.5	35
20	238		226	60.5	97.8	34
(18)	230		219	–	96.7	33
(16)	222		212	–	95.5	32
(14)	213		203	–	93.9	31
(12)	204		194	–	92.3	29
(10)	196		187		90.7	28
(8)	188		179		89.5	27
(6)	180		171		87.1	26
(4)	173		165		85.5	25
(2)	166		158		83.5	24
(0)	160		152		81.7	24

Supplementary table 14 Surface roughness comparison

Arithmetical mean deviation of the profile R_a	Maximum height of the profile R_{max}	Ten-point height of irregularities R_z	Roughness grade numbers N
0.013 a	0.05 S	0.05 Z	–
0.025 a	0.1 S	0.1 Z	N 1
0.05 a	0.2 S	0.2 Z	N 2
0.10 a	0.4 S	0.4 Z	N 3
0.20 a	0.8 S	0.8 Z	N 4
0.40 a	1.6 S	1.6 Z	N 5
0.80 a	3.2 S	3.2 Z	N 6
1.6 a	6.3 S	6.3 Z	N 7
3.2 a	12.5 S	12.5 Z	N 8
6.3 a	25 S	25 Z	N 9
12.5 a	50 S	50 Z	N 10
25 a	100 S	100 Z	N 11
50 a	200 S	200 Z	N 12
100 a	400 S	400 Z	–

[Note] Above table is applicable only when processed surface peaks are of equal height.
 Above table is roughly applicable to processed surface for general use.
 Numbers are combined only for convenience in deciding surface roughness.

Supplementary table 15 Viscosity conversion

Kinematic viscosity mm ² /s	Saybolt SUS (second)		Redwood R (second)		Engler E (degree)
	100°F	210°F	50°C	100°C	
2	32.6	32.8	30.8	31.2	1.14
3	36.0	36.3	33.3	33.7	1.22
4	39.1	39.4	35.9	36.5	1.31
5	42.3	42.6	38.5	39.1	1.40
6	45.5	45.8	41.1	41.7	1.48
7	48.7	49.0	43.7	44.3	1.56
8	52.0	52.4	46.3	47.0	1.65
9	55.4	55.8	49.1	50.0	1.75
10	58.8	59.2	52.1	52.9	1.84
11	62.3	62.7	55.1	56.0	1.93
12	65.9	66.4	58.2	59.1	2.02
13	69.6	70.1	61.4	62.3	2.12
14	73.4	73.9	64.7	65.6	2.22
15	77.2	77.7	68.0	69.1	2.32
16	81.1	81.7	71.5	72.6	2.43
17	85.1	85.7	75.0	76.1	2.54
18	89.2	89.8	78.6	79.7	2.64
19	93.3	94.0	82.1	83.6	2.76
20	97.5	98.2	85.8	87.4	2.87
21	102	102	89.5	91.3	2.98
22	106	107	93.3	95.1	3.10
23	110	111	97.1	98.9	3.22
24	115	115	101	103	3.34
25	119	120	105	107	3.46
26	123	124	109	111	3.58
27	128	129	112	115	3.70
28	132	133	116	119	3.82
29	137	138	120	123	3.95
30	141	142	124	127	4.07
31	145	146	128	131	4.20
32	150	150	132	135	4.32
33	154	155	136	139	4.45
34	159	160	140	143	4.57

Kinematic viscosity mm ² /s	Saybolt SUS (second)		Redwood R (second)		Engler E (degree)
	100°F	210°F	50°C	100°C	
35	163	164	144	147	4.70
36	168	170	148	151	4.83
37	172	173	153	155	4.96
38	177	178	156	159	5.08
39	181	183	160	164	5.21
40	186	187	164	168	5.34
41	190	192	168	172	5.47
42	195	196	172	176	5.59
43	199	201	176	180	5.72
44	204	205	180	185	5.85
45	208	210	184	189	5.98
46	213	215	188	193	6.11
47	218	219	193	197	6.24
48	222	224	197	202	6.37
49	227	228	201	206	6.50
50	231	233	205	210	6.63
55	254	256	225	231	7.24
60	277	279	245	252	7.90
65	300	302	266	273	8.55
70	323	326	286	294	9.21
75	346	349	306	315	9.89
80	371	373	326	336	10.5
85	394	397	347	357	11.2
90	417	420	367	378	11.8
95	440	443	387	399	12.5
100	464	467	408	420	13.2
120	556	560	490	504	15.8
140	649	653	571	588	18.4
160	742	747	653	672	21.1
180	834	840	734	757	23.7
200	927	933	816	841	26.3
250	1159	1167	1020	1051	32.9
300	1391	1400	1224	1241	39.5

[Remark] 1mm²/s = 1 cSt (centi stokes)

GLOBAL NETWORK

BEARING BUSINESS OPERATIONS

JTEKT CORPORATION NAGOYA HEAD OFFICE

No.7-1, Meieki 4-chome, Nakamura-ku, Nagoya, Aichi 450-8515,
JAPAN
TEL : 81-52-527-1900
FAX : 81-52-527-1911

JTEKT CORPORATION OSAKA HEAD OFFICE

No.5-8, Minamisemba 3-chome, Chuo-ku, Osaka 542-8502,
JAPAN
TEL : 81-6-6271-8451
FAX : 81-6-6245-3712

Sales & Marketing Headquarters

No.5-8, Minamisemba 3-chome, Chuo-ku, Osaka 542-8502,
JAPAN
TEL : 81-6-6245-6087
FAX : 81-6-6244-9007

OFFICES

KOYO CANADA INC.

5324 South Service Road, Burlington, Ontario L7L 5H5, CANADA
TEL : 1-905-681-1121
FAX : 1-905-681-1392

KOYO CORPORATION OF U.S.A.

-Cleveland Office-

29570 Clemens Road, P.O.Box 45028 Westlake,
OH 44145, U.S.A.
TEL : 1-440-835-1000
FAX : 1-440-835-9347

-Detroit Office-

47771 Halyard Drive, Plymouth, MI 48170, U.S.A.
TEL : 1-734-454-1500
FAX : 1-734-454-4076

KOYO MEXICANA, S.A. DE C.V.

Rio Nazas No.171, 3er piso, Col. Cuauhtemoc, México, D.F. C.P.
06500, MÉXICO
TEL : 52-55-5207-3860
FAX : 52-55-5207-3873

KOYO LATIN AMERICA, S.A.

Edificio Banco del Pacifico Planta Baja, Calle Aquilino de la
Guardia y Calle 52, Panama, REPUBLICA DE PANAMA
TEL : 507-208-5900
FAX : 507-264-2782/507-269-7578

KOYO ROLAMENTOS DO BRASIL LTDA.

Rua Desembargador Eliseu Ghlherme 304, 7-Andar, Paraiso,
CEP 04004-30, BRASIL
TEL : 55-11-3887-9173
FAX : 55-11-3887-3039

JTEKT (THAILAND) Co., LTD.

172/1 Moo 12 Tambol Bangwua, Amphur Bangpakong,
Chachoengsao 24180, THAILAND
TEL : 66-38-533-310-7
FAX : 66-38-532-776

PT. JTEKT INDONESIA

MM2100 Industrial Town Block DD-3, Cikarang Barat, Bekasi
17520, INDONESIA
TEL : 62-21-8998-3273
FAX : 62-21-8998-3274

KOYO SINGAPORE BEARING (PTE.) LTD.

27, Penjuru Lane, #09-01 C&P Logistics Hub 2, SINGAPORE
609195
TEL : 65-6274-2200
FAX : 65-6862-1623

-MIDDLE EAST (BRANCH)-

6EA312, Dubai Airport Free Zone, P.O. Box 54816, Dubai, U.A.E.
TEL : 971-4-2993600
FAX : 971-4-2993700

PHILIPPINE KOYO BEARING CORPORATION

6th Floor One World Square Building, #10 Upper McKinley Road,
McKinley Town Center, Fort Bonifacio, 1634 Taguig City,
PHILIPPINES
TEL : 63-2-856-5046/5047
FAX : 63-2-856-5045

JTEKT KOREA CO., LTD.

Inwoo Building 6F, 539-11, Shinsa-Dong,
Kangnam-Ku, Seoul, KOREA
TEL : 82-2-549-7922
FAX : 82-2-549-7923

JTEKT (CHINA) CO., LTD.

Rm.1906, Aetna Tower, 107 Zunyi Road, Shanghai, 200051,
CHINA
TEL : 86-21-6237-5280
FAX : 86-21-6237-5277

KOYO (SHANGHAI) CO., LTD.

Rm.1905, Aetna Tower, 107 Zunyi Road, Shanghai, 200051,
CHINA
TEL : 86-21-6237-5280
FAX : 86-21-6237-5277

KOYO AUSTRALIA PTY. LTD.

Unit 2, 8 Hill Road, Homebush Bay, NSW 2127, AUSTRALIA
TEL : 61-2-8719-5300
FAX : 61-2-8719-5333

JTEKT EUROPE BEARINGS B.V.

Markerkant 13-01, 1314 AN Almere, THE NETHERLANDS
TEL : 31-36-5383333
FAX : 31-36-5347212

KOYO KULLAGER SCANDINAVIA A.B.

Johanneslundsvägen 4, 194 61 Upplands Väsby, SWEDEN
TEL : 46-8-594-212-10
FAX : 46-8-594-212-29

KOYO (U.K.) LTD.

Whitehall Avenue, Kingston, Milton Keynes MK10 OAX,
UNITED KINGDOM
TEL : 44-1908-289300
FAX : 44-1908-289333

KOYO ROMANIA REPRESENTATIVE OFFICE

Str. Frederic Jolliot-Curie, Nr.3, Etaj 1, Ap.2, Sector 5
Bucharest, ROMANIA
TEL : 40-21-410-4170/4182/0984
FAX : 40-21-410-1178

KOYO DEUTSCHLAND GMBH.

Bargkoppelweg 4, D-22145 Hamburg, GERMANY
TEL : 49-40-67-9090-0
FAX : 49-40-67-9203-0

KOYO FRANCE S.A.

8 Rue Guy Moquet, B.P.189 Z.I., 95105 Argenteuil Cedex, FRANCE
TEL : 33-1-3998-4202
FAX : 33-1-3998-4244/4249

KOYO IBERICA, S.L.

Avda.da la Industria, 52-2 izda 28820
Coslada Madrid, SPAIN
TEL : 34-91-329-0818
FAX : 34-91-747-1194

KOYO ITALIA S.R.L.

Via Bronzino 9, 20133 Milano, ITALY
TEL : 39-02-2951-0844
FAX : 39-02-2951-0954

BEARING PLANTS

KOYO CORPORATION OF U.S.A. (MANUFACTURING DIVISION)

-Orangeburg Plant-

2850 Magnolia Street, Orangeburg, SC 29115, U.S.A.
TEL : 1-803-536-6200
FAX : 1-803-534-0599

-Richland Plant-

1006 Northpoint Blvd., Blythewood, SC 29016, U.S.A.
TEL : 1-803-691-4624/4633
FAX : 1-803-691-4655

JTEKT (THAILAND) Co., LTD.

172/1 Moo 12 Tambol Bangwua, Amphur Bangpakong,
Chachoengsao 24180, THAILAND
TEL : 66-38-531-988/993
FAX : 66-38-531-996

KOYO MANUFACTURING (PHILIPPINES) CORP.

Lima Technology Center, Municipality of Malvar, Batangas
Province, 4233 PHILIPPINES
TEL : 63-43-981-0088
FAX : 63-43-981-0001

KOYO JICO KOREA CO., LTD

28-12, Yulpo-Ri, Koduc-Myun, Pyung Teak-City, Kyungki-Do, KOREA
TEL : 82-31-668-6381
FAX : 82-31-668-6384

KOYO BEARING DALIAN CO., LTD.

No.II A-2 Dalian Export Processing Zone, 116600, CHINA
TEL : 86-411-8731-0972/0974
FAX : 86-411-8731-0973

WUXI KOYO BEARING CO., LTD.

Wuxi Li Yuan Economic Development Zone, Wuxi, 214072,
CHINA
TEL : 86-510-85161901
FAX : 86-510-85161143

DALIAN KOYO WAZHOU AUTOMOBILE BEARING CO., LTD.

No.96, Liaohe East Road, D.D Port, Dalian, 116620, CHINA
TEL : 86-411-8740-7272
FAX : 86-411-8740-7373

KOYO LIOHO (FOSHAN) AUTOMOTIVE PARTS CO., LTD.

No.12, Wusha Section Of Shunpan Road, Daliang Town, Shunde
Of Foshan, Guandong, Province, CHINA
(SHUNDE INDUSTRIAL PARK)
TEL : 86-757-22829589
FAX : 86-757-22829586

KOYO AUTOMOTIVE PARTS (WUXI) CO.,LTD.

B6-A New District, Wuxi, 214028, CHINA
TEL : 86-510-8533-0909
FAX : 86-510-8533-0155

KOYO BEARINGS (EUROPE) LTD.

P.O.Box 101, Elmhirst Lane, Dodworth, Barnsley,
South Yorkshire, S75 3TA, UNITED KINGDOM
TEL : 44-1226-733200
FAX : 44-1226-204029

KOYO ROMANIA S.A.

Turnu Magurele Street No.1, 140003, ALEXANDRIA Teleorman
County, ROMANIA
TEL : 40-247-306-400
FAX : 40-247-306-421

TECHNICAL CENTERS

JTEKT CORPORATION NORTH AMERICAN TECHNICAL CENTER

47771 Halyard Drive, Plymouth, MI 48170, U.S.A.
TEL : 1-734-454-1500
FAX : 1-734-454-4076

JTEKT (CHINA) CO., LTD. TECHNICAL CENTER

Rm.1905, Aetna Tower, 107 Zunyi Road, Shanghai, 200051,
CHINA
TEL : 86-21-6237-5280
FAX : 86-21-6237-5277

JTEKT CORPORATION EUROPEAN TECHNICAL CENTRE

Markerkant 13-02, 1314 AN Almere, THE NETHERLANDS
TEL : 31-36-5383350
FAX : 31-36-5302656

Koyo® Ball & Roller Bearings



This catalog has been printed on paper of recycled paper pulp using environmentally friendly soy ink.

CAT. NO. B2001E-3

Printed in Japan '09.09-3CDS ('06.1)

JTEKT

JTEKT CORPORATION