



NEEDLE ROLLER BEARINGS

JNS

the best choice you ever made

JNS

the best choice you ever made

*A Specialist in
Needle Roller Bearing Manufacturing*



Technical information

NEEDLE ROLLER BEARINGS [\(P.10-51\)](#)

CAM FOLLOWERS [\(P.116-129\)](#)

ROLLER FOLLOWERS [\(P.174-181\)](#)

NEEDLE ROLLER BEARINGS

 RNA49, RNA59, RNA69, RNA48, NK [\(P.52-69\)](#)

 RNA49UU, RNA69UU, SEALED [\(P.80-81\)](#)

 NA49, NA59, NA69, NA48, NKI [\(P.70-79\)](#)

 NA49UU, NA69UU, SEALED [\(P.82-83\)](#)

CAM FOLLOWERS

New Product Introductions [\(P.114-115\)](#)

 CFS..A [\(P.130-131\)](#)

 CF..A [\(P.134-137\)](#)

 NUCF [\(P.142-143\)](#)

 CF-SFU [\(P.132-133\)](#)

 CF..AB [\(P.138-141\)](#)

 CF [\(P.144-147\)](#)

ROLLER FOLLOWERS

 RNAS [\(P.182-183\)](#)

 NAS [\(P.184-185\)](#)

STAINLESS STEEL

NEEDLE ROLLER BEARINGS STAINLESS STEEL

 RNA49..M, NK..M [\(P.194-197\)](#)

 NA49..M, NKI..M [\(P.198-199\)](#)

CAM FOLLOWERS STAINLESS STEEL

 CFS..MA [\(P.206-207\)](#)

 CF..MAB [\(P.212-215\)](#)

 CF..MB [\(P.220-221\)](#)

 CF..MA [\(P.208-211\)](#)

 CF..M [\(P.216-219\)](#)

 CFH..MA [\(P.222-225\)](#)

ROLLER FOLLOWERS STAINLESS STEEL

 RNAS..M [\(P.244-245\)](#)

 NAS..M [\(P.246-247\)](#)

INTERCHANGE TABLE

NEEDLE ROLLER BEARINGS [\(P.254-293\)](#) CAM FOLLOWERS [\(P.294-325\)](#)

INTERCHANGE TABLE STAINLESS STEEL

NEEDLE ROLLER BEARINGS [\(P.338-343\)](#) CAM FOLLOWERS [\(P.344-367\)](#)

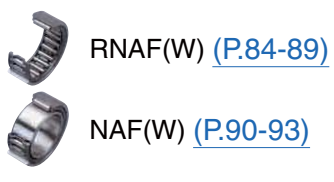

RNAF(W) [\(P.84-89\)](#)

NAF(W) [\(P.90-93\)](#)



IR,IRZ [\(P.94-111\)](#)



CF.B [\(P.148-149\)](#)

CFH..A [\(P.150-153\)](#)



CFH..AB [\(P.154-157\)](#)

CFH [\(P.158-161\)](#)



CFH..B [\(P.162-163\)](#)

CFT [\(P.164-167\)](#)



CFT..A [\(P.168-169\)](#)

CR [\(P.170-171\)](#)



NAST..ZZ [\(P.186-187\)](#)



NART [\(P.188-189\)](#)



NURT [\(P.190-191\)](#)



IR..M [\(P.200-203\)](#)

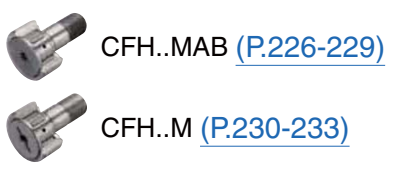

CFH..MAB [\(P.226-229\)](#)

CFH..M [\(P.230-233\)](#)

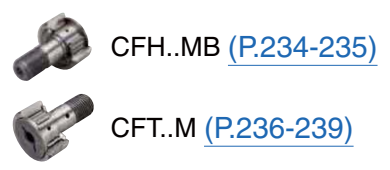

CFH..MB [\(P.234-235\)](#)

CFT..M [\(P.236-239\)](#)

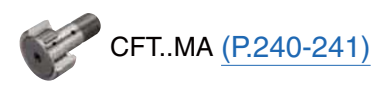

CFT..MA [\(P.240-241\)](#)



NAST..MZZ [\(P.248-249\)](#)



NART.. M [\(P.250-251\)](#)

ROLLER FOLLOWERS [\(P.326-335\)](#)

ROLLER FOLLOWERS [\(P.368-373\)](#)

NEEDLE ROLLER BEARINGS

CAM FOLLOWERS

ROLLER FOLLOWERS

NEEDLE ROLLER BEARINGS
STAINLESS STEEL

CAM FOLLOWERS
STAINLESS STEEL

ROLLER FOLLOWERS
STAINLESS STEEL

INTERCHANGE

INTERCHANGE
STAINLESS STEEL

JNS supports custom manufacturing in cutting-edge industries where high precision and high performance are required.

PRODUCTS



Needle Roller Bearings

A needle roller bearing featuring high-precision rigid outer rings and retainers. Its space-saving design provides low cross-sectional height.



Cam Followers

Our stud-type cam followers have a thick outer ring and can support heavy radial loads. They are designed for applications where the outer ring rotates. Also available in miniature models.



Needle Roller Bearings (STAINLESS STEEL)

A durable stainless-steel bearing that is rust- and corrosion-resistant. Used in lithium ion battery intergrated system, semi-conductors, medical equipments, and food machinery.

Product lineups that meet cutting-edge industry needs

Our needle bearing products boast high-precision, high-rigidity, and high-durability. They are widely used in production lines for advanced products, such as digital home appliances, as well as in manufacturing facilities for semiconductor manufacturing devices, precise construction machinery, and electron microscopes. Our technology supports every type of industry in the world.

A substantial variety of products delivered promptly

Aside from providing our customers with a stable supply of products, immediate delivery has been the standard at Nose Seiko for many years. We achieve this through our flexible and efficient production system—the result of extensive industry experience—that ensures we are always able to keep an extensive array of products on hand. Nose Seiko strives to provide optimum convenience for customers, responding to emergency orders within the shortest possible delivery time. Our customers appreciate our commitment to high standards.

JNS



Roller Followers

Our roller followers have a thick outer ring to support large radial loads. This bearing is designed for applications where the outer ring rotates.



Cam Followers (STAINLESS STEEL)

A durable stainless-steel bearing that is rust- and corrosion-resistant. Used in cutting-edge technological fields for anticorrosive, clean, and vacuum applications.



Roller Followers (STAINLESS STEEL)

A durable stainless-steel bearing that is rust- and corrosion-resistant. Used in cutting-edge technological fields for anticorrosive, clean, and vacuum applications.

JNS provides the highest quality products to fulfill satisfaction of the worldwide customers.



GLOBAL NETWORK



North America

South America

JNS

In order to fulfill satisfaction of the worldwide customers

Nose Seiko consistently answers any type of orders by supplying products with best quality all the time. Thanks to such assurance for the quality, it promises comfortable and secure purchasing of whatever product required whenever needed for the customers all over the world.

The JNS network spans over 50 countries

Our network of sales distributors currently over 50 countries in North and South America, Europe, Asia, Oceania, the Middle East, and Africa. The extensive scale of our network is a proof of the superior quality of our delivery system, which proves trust in the worldwide customers.

NEEDLE ROLLER BEARINGS



1 Bearing Life and Load Rating

1-1 Bearing life

Bearings are subjected to certain intensity of repeating stress on their track ring and rolling element even during operation under proper loading, appropriate mounting and sufficient lubrication. The stress may cause scaly damage formed on surface after certain time period due to its concentration at shallow vicinity under the surface. This phenomenon is called flaking (peeling-off of surface). Phenomenon that causes bearing to be unusable due to flaking caused by repeating cyclic stress under normal operating condition is called "life" of the bearing. Generally, bearing life is defined by total number of rotation of the bearing until flaking is generated on track surface. However, recognizing average life as criteria of bearing life is not appropriate for actual selection of bearing since fatigue limit of material varies. It shall be practical to consider the life guaranteed to most bearings (basic rating life) as a criterion. Phenomenon that bearing becomes inoperative due to heat-seizure, wear, fracture, scoring are regarded as "failure" caused by operating conditions and selection of bearing so that they and the life should be considered as different phenomena.

1-2 Basic rating life

Basic rating life of bearing shall be defined as a total number of rotation that 90% of the group of the same bearings can run without causing flaking due to rolling fatigue when they are operated under the same conditions.

In the case of rotation in certain constant speed, the basic rating life can be expressed in a total rotation time as well.

1-3 Basic dynamic load rating

A given static radial load under which a bearing theoretically endures basic rating life of one million rotations is referred to as a basic dynamic load rating.

1-4 Dynamic equivalent load

Dynamic equivalent radial load

A load that is virtually applied to the center of a bearing under which to obtain a life equivalent to that when both radial load and axial load are subjected to the bearing at the same time is called the dynamic equivalent radial load. In the case of needle bearing, its radial type is capable for loading radial load only so that just a radial load will be applied.

1-5 Bearing life calculation formula

The following relationship is applied to basic rating life, basic dynamic load rating and dynamic equivalent load of bearing.

$$L_{10} = (Cr / Pr)^{10/3} \dots \dots \dots (1.1)$$

- L_{10} : Basic rating life 10^6 rotation
- Cr : Basic dynamic load rating N
- Pr : Dynamic equivalent radial load N

Basic rating life time can be expressed as total rotation time with given rotation per minute by the following formula.

$$L_h = 10^6 L_{10} / 60n = 500 f_h^{10/3} \dots \dots \dots (1.2)$$

$$f_h = f_n Cr / Pr \dots \dots \dots (1.3)$$

$$f_n = (33.3 / n)^{3/10} \dots \dots \dots (1.4)$$

- L_h : Basic rating life expressed in hour h
- n : Rotation per minute rpm
- f_h : Bearing life factor
- f_n : Speed factor

1-6 Operating conditions and bearing life factor of bearing

Operating machinery and demanded life

Bearings should be selected based on setting up demanded life in accordance with operating machinery and operating condition.

Demanded life is determined by endurance duration for operating machinery and reliable operating periods.

Table-1 indicates demanded life that can be a typical reference.

Table-1 Operating condition and demanded life time factor (reference)

Operating conditions	Bearing life factor f_h				
	~3	2~4	3~5	4~7	6~
Short duration or occasional operation	Home appliance Electrical tools	Agricultural machinery Office equipment			
Short duration or occasional operation, but necessity for ensuring reliable operation	Medical equipment Measuring instrument	Home air conditioning Construction machinery Crane	Elevator	Crane (sheave wheel)	
Long duration operation but not full time		Small size motor General gear system Woodworking machinery Passenger car	Machine tools Factory general purpose motor Crusher	Important gear system Calendar roller for rubber and plastic Printing machine	
Continuous operation over eight hours a day		Rolling machine Escalator Conveyer Centrifugal separator	Air conditioner Large size motor Compressor, pump	Mine hoist Press machine	Pulp, papermaking machine
Operate 24 hours a day and must be non stop without accident					Water-work system Power generator system

1-7 Corrected rating life

Formula for basic rating life described above is applied to bearings whose reliability is 90%, whose material is for general purpose bearing and are manufactured in general quality standard as well as those operated under standard operating conditions. Corrected rating life should be calculated using correction factor a_1 , a_2 and a_3 in the case that the reliability is over 90% or that life needs to be obtained for special bearing properties or for special operating conditions.

$$L_{na} = a_1 a_2 a_3 L_{10} \dots \dots \dots (1.5)$$

- L_{na} : Adjustment rating life 10^6 rotation
- a_1 : Reliability factor
- a_2 : Bearing special properties factor
- a_3 : Operating conditions factor

1-7-1 Reliability factor

Reliability factor a_1

This is the bearing life corrected factor for reliability (100-n) % when probability of failure is n %. Value of the reliability factor a_1 is shown in Table-2.

Table-2 Reliability factor a_1

Reliability (%)	L_n	a_1
90	L_{10}	1
95	L_5	0.62
96	L_4	0.53
97	L_3	0.44
98	L_2	0.33
99	L_1	0.21

1-7-2 Bearing special properties factor

Bearing special properties factor a_2

Bearing special properties factor a_2 is used for adjusting variation of properties concerning life in the case that material type, quality or manufacturing process is special. This factor shall be $a_2=1$ for standard material and manufacturing method. It can be $a_2 > 1$ when special modified material or manufacturing method is used due to improved quality of bearing material or progress of manufacturing technology.

1-7-3 Operating conditions factor

Operating conditions factor a_3

This is a factor to adjust impact of operating conditions of bearing, especially effect of lubrication to fatigue life. Bearing life is essentially a fatigue phenomenon of surface layer which is subjected to repeating cyclic load. Therefore, this factor will be $a_3=1$ under ideal lubrication condition when rolling element and track surface are completely isolated by oil film and surface failure can be ignored. Under poor lubrication condition such as low lubricant viscosity or under significantly slow rotation speed of rolling element, it would be $a_3 < 1$.

On the contrary, it can be $a_3 > 1$ under especially excellent lubrication condition. Generally, the bearing special properties factor a_2 can not be set to value exceeding 1 when $a_3 < 1$.

1-8 Adjustment of Basic Dynamic Load Rating for temperature and hardness factors

1-8-1 Temperature factor

While operating temperature of bearing is individually defined in accordance with material and structure, bearing is capable to be used at temperatures higher than 150 °C by applying special treatment for thermal resistance. However this will cause reduction of basic dynamic load rating as a result of reduction of permissive contact stress. Basic dynamic load rating with consideration for temperature increase is given by the following formula.

$$C_1 = f_1 Cr \dots \dots \dots (1.6)$$

- C_1 : Basic dynamic load rating with consideration for temperature increase N
- f_1 : Temperature factor (Refer to Figure-1)
- Cr : Basic dynamic load rating N

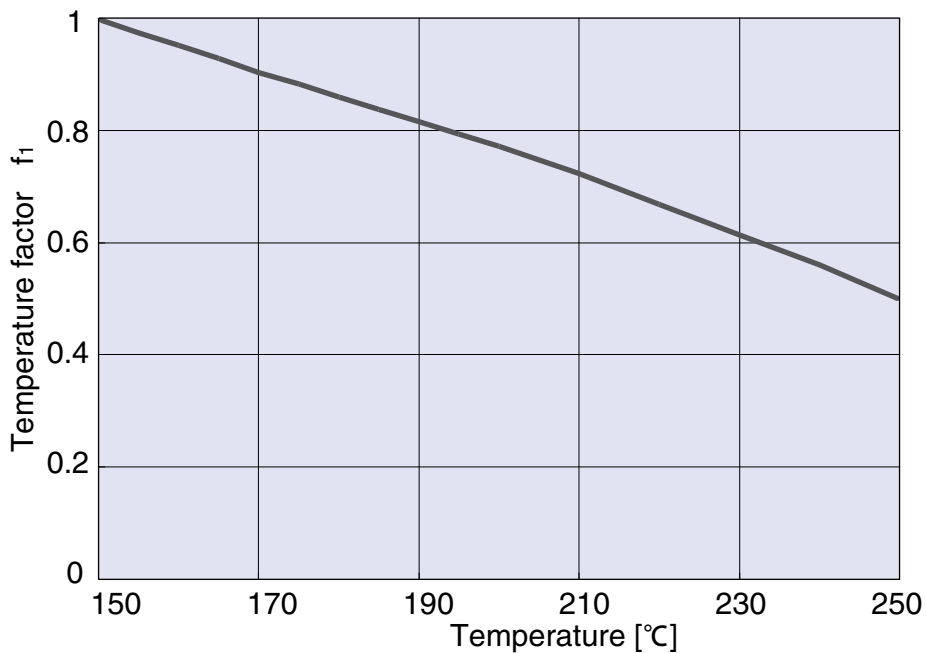

Figure-1

1-8-2 Hardness factor

The raceway surface should be HRC58 to 64 in the case of using shaft or housing as raceway instead of bearing inner ring or outer ring respectively. Basic dynamic load rating may be reduced in the case the surface hardness is lower than HRC58. Basic dynamic load rating with consideration for surface hardness is given by the following formula.

$$C_2 = f_2 Cr \dots\dots\dots (1.7)$$

- C_2 : Basic dynamic load rating with consideration for hardness N
- f_2 : Hardness factor (Refer to Figure-2)
- Cr : Basic dynamic load rating N

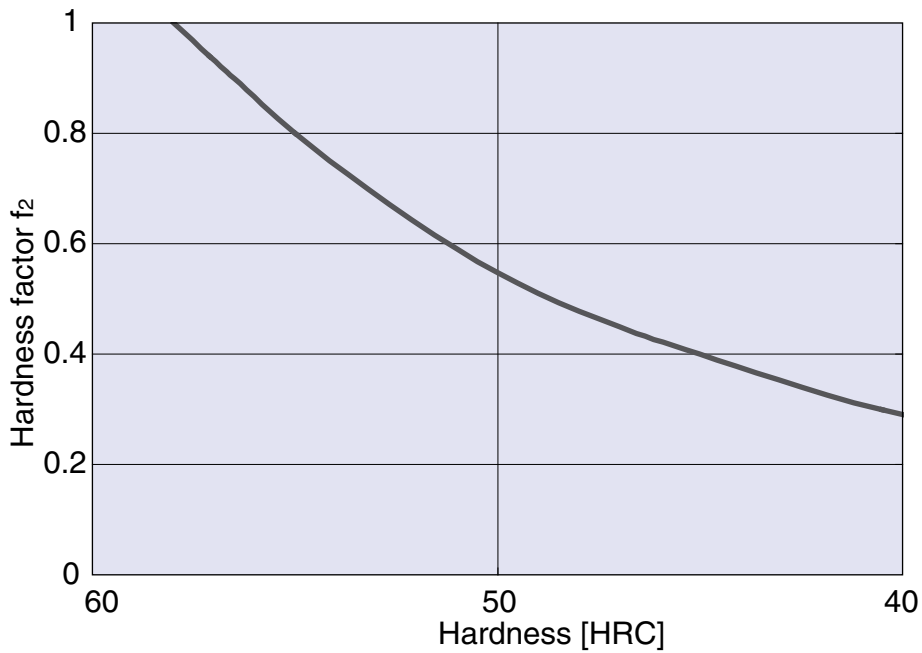

Figure-2

1-9 Basic static load rating

Basic static load rating is specified as a static load which corresponds to contact stress indicated in the table below at rolling element and the center of contact of track that are subjected to the maximum load. Total permanent deformation of rolling element and track occurred by the contact stress may be approximately 0.0001 times of diameter of the rolling element.

Type of bearing	Contact stress MPa
Roller bearing	4000

1-10 Static equivalent load

A load that is virtually applied to the center of a bearing under which to obtain a contact stress equivalent to the maximum contact stress that occurs at contact surface between rolling element and track, when both radial load and axial load are subjected to the bearing at the same time, is called a static equivalent load.

In the case of needle bearing, its radial type is capable for loading radial load only so that just a radial load will be applied.

$$P_{Or} = F_r \dots\dots\dots (1.8)$$

P_{Or} : Static equivalent radial load N

1-11 Static safety factor

Although permissive limit of static equivalent load is typically regarded as basic static load rating, its limit shall be set with consideration for safety since conditions required for bearings broadly vary. The static safety factor f_s is given by the following formula (1.9). Table-3 shows its typical values.

$$f_s = \frac{C_{Or}}{P_{Or}} \dots\dots\dots (1.9)$$

f_s : Safety factor

C_{Or} : Basic static load rating N

Table-3 Static safety factor

Operating conditions of bearing	f_s
With high rotation accuracy With impact load	≥ 3
With standard rotation accuracy	≥ 1.5
With standard rotation accuracy and low speed	≥ 1

1-12 Permissive rotation speed

Increasing bearing rotation speed may cause a rise in bearing temperature due to abrasion heat generated inside of the bearing, which results in failure with heat-seizure. A threshold rotation speed up to which long duration of safe operation is enabled is referred to as a permissive rotation speed.

Permissive rotation speed varies depending on type, size and load of bearing, lubrication method and its radial clearance. It is an experimental value at which operation is enabled without causing heat generation exceeding certain limit.

2 Bearing load

2-1 Load factor

Operation in actual machinery is subjected to a load larger than theoretical axial directional load due to vibration and impact shock.

Actual load is given by calculation of load applied to axes system using load factor shown in Table-4.

$$K = f_w \cdot K_c \cdot \dots \dots \dots (2.1)$$

- K : Actual load applied to axes system N
- K_c : Theoretical calculation value N
- f_w : Load factor (Table-4)

Table-4 Load factor

Degree of load	Examples	f_w
Smooth motion without any impacts	Air conditioner, measurement instruments, office equipment	1 ~1.2
With standard rotation	Gear box, vehicle, paper-making machine	1.2~1.5
Operation with vibration and impact shock	Rolling machine, construction machinery, crusher	1.5~3

2-2 Load distribution

Load distribution to bearing

Axes system is assumed as a static beam supported by bearings in order to distribute load acting on the axes system to the bearings. Table-5 shows calculation example of load distribution.

Table-5 Example of calculation of load distribution

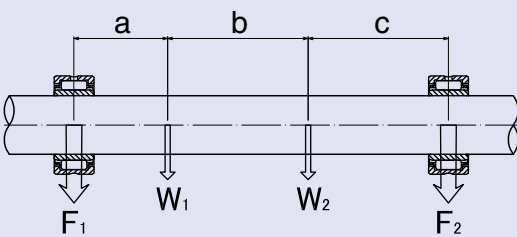
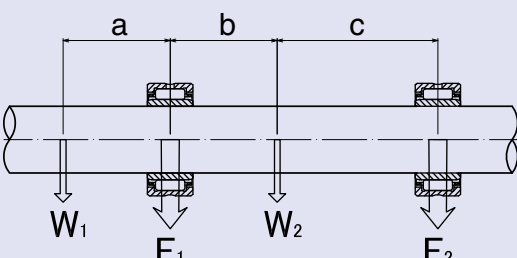
Examples	Load calculation
	$F_1 = \frac{W_1(b + c) + W_2c}{a + b + c}$ $F_2 = \frac{W_1a + W_2(a + b)}{a + b + c}$
	$F_1 = \frac{W_1(a + b + c) + W_2c}{b + c}$ $F_2 = \frac{W_2b - W_1a}{b + c}$

2-3 Load transmission

Bearing loads in belt or chain transmission

The force acting on pulley or sprocket wheel when power is transmitted by a belt or chain is given by the following formula.

$$T = 9550P/N \dots \dots \dots (2.2)$$

$$F_t = 2000 \cdot T/d \dots \dots \dots (2.3)$$

- T*** : Torque acting on pulley or sprocket wheel N·m
- F_t*** : Effective force transmitted by belt or chain N
- P*** : Transmitted power kW
- N*** : Rotation per minute rpm
- d*** : Effective diameter of pulley or sprocket wheel mm

Load *F_r* acting on pulley shaft is given by multiplying effective transmitted force *F_t* by belt factor *f_b* shown in Table-6 in the case of belt transmission.

$$F_r = f_b F_t \dots \dots \dots (2.4)$$

Table-6 Belt factor

Type of belt	<i>f_b</i>
V belt	2 ~2.5
Flat belt (with tension pulley)	2.5~3
Flat belt (without tension pulley)	4 ~5

In the case of chain transmission, load acting on sprocket wheel shaft is given by the formula (2.4) as same as that of belt transmission using value between 1.2 and 1.5 as chain factor corresponding to *f_b*.

Bearing loads in gear transmission

In the case of power transmission by gear, methods of calculation vary depending on the type of gear since force acting on the gear is divided into radial load and axial load and their direction and ratio vary depending on the type of gear. In the case of the simplest flat gear, direction of load is radial load only and it is given by the following formula.

$$T = 9550P/N \dots\dots\dots (2.5)$$

$$F_t = 2000 \cdot T/d \dots\dots\dots (2.6)$$

$$F_r = F_t \cdot \tan \alpha \dots\dots\dots (2.7)$$

$$F_c = \sqrt{F_t^2 + F_r^2} \dots\dots\dots (2.8)$$

- T** : Torque acting on gear N·m
- F_t** : Force in tangent direction of gear N
- F_r** : Force in radial direction of gear N
- F_c** : Combine force acting perpendicular to gear N
- P** : Transmitted power kW
- N** : Rotation per minute rpm
- d** : Pitch circle diameter of drive gear mm
- α** : Pressure angle of gear

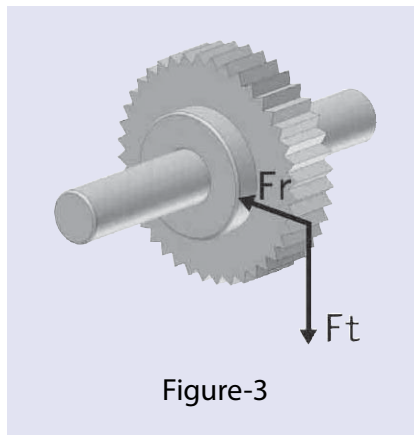

Figure-3

Value that is given by multiplying theoretical load by gear factor f_z in Table-7 shall be used as actual load since degree of vibration and impact shock affecting the theoretical load obtained by the formula above varies depending on the type of gear and accuracy of gear surface finish.

$$F = f_z F_c \dots\dots\dots (2.9)$$

Table-7 Gear factor

Type of gear	f_z
Precision gear (Both of pitch error and geometric error is 0.02 mm or less)	1.05~1.1
Ordinary machined gear (Both of pitch error and geometric error is between 0.02 mm and 0.1 mm)	1.1 ~1.3

Average load

Average load F_m which is converted so as to apply even life to each bearing may be used in the case that load acting on bearing is unstable and changes in various cycle.

(1) Fluctuating step load

Average load F_m is given by formula (2.10) in the case that bearing load $F_1, F_2, F_3 \dots$ is applied with rotation speed and operation duration of $n_1, n_2, n_3 \dots$ and $t_1, t_2, t_3 \dots$ respectively.

$$F_m = \left[\frac{F_1^{10/3} \cdot n_1 t_1 + F_2^{10/3} \cdot n_2 t_2 + \dots + F_n^{10/3} \cdot n_n t_n}{n_1 t_1 + n_2 t_2 + \dots + n_n t_n} \right]^{3/10} \dots \dots \dots (2.10)$$

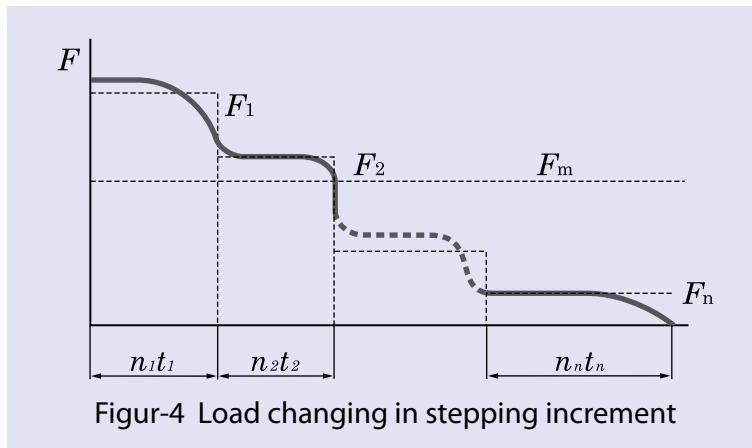

(2) Continuously fluctuating load

Average load is given by formula (2.11) in the case that the load can be expressed in function $F(t)$ of time t with cycle t_0 .

$$F_m = \left[\frac{1}{t_0} \int_0^{t_0} F(t)^{10/3} dt \right]^{3/10} \dots \dots \dots (2.11)$$

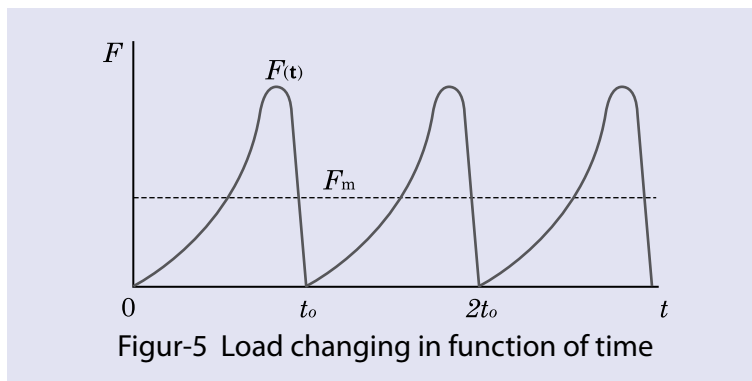

(3) Roughly linear load

Average load F_m is approximately given by formula (2.12).

$$F_m = \frac{F_{min} + 2F_{max}}{3} \dots\dots\dots (2.12)$$

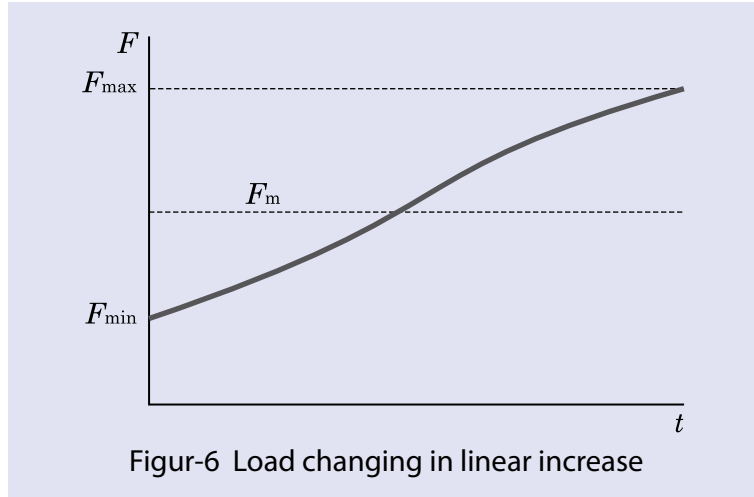

(4) Sinusoidal fluctuating load

Average load F_m is approximately given by formula (2.13) and formula (2.14).

(a): $F_m = 0.75F_{max}$ (2.13)

(b): $F_m = 0.65F_{max}$ (2.14)

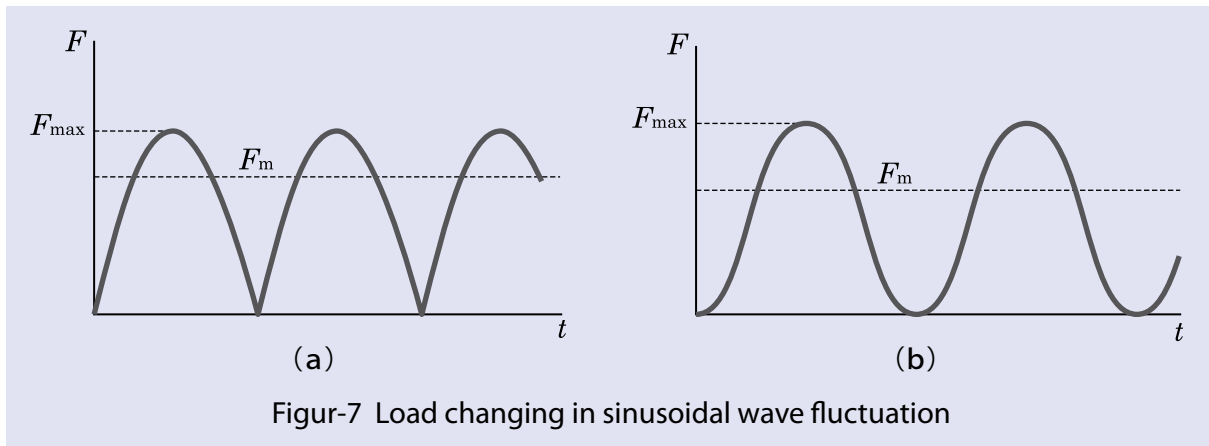

3 Bearing accuracy

3-1 Accuracy

Dimensional accuracy, geometrical accuracy and rotation accuracy of bearing are specified in ISO standards and JIS B 1514 (Rolling bearings - Tolerances of bearings).

Accuracy class of needle bearing is specified by four classes from lowest class 0 to 6th, 5th and 4th class in the highest. While high accuracy bearing in 5th or 4th class may be used in application for the case high rotation accuracy is demanded or high speed rotation, class 0 is used in most of general purpose application.

Table-8 Accuracy of inner ring

d Nominal bearing bore diameter (mm)		Δ_{dmp} Deviation of mean bore diameter in a single plane								V_{dsp} Variation of bore diameter in a single plane				V_{dmp} Variation of mean bore diameter in a single plane			
		0		6		5		4		0	6	5	4	0	6	5	4
Over	Incl.	high	low	high	low	high	low	high	low	max.				max.			
2.5 ¹⁾	10	0	-8	0	-7	0	-5	0	-4	10	9	5	4	6	5	3	2
10	18	0	-8	0	-7	0	-5	0	-4	10	9	5	4	6	5	3	2
18	30	0	-10	0	-8	0	-6	0	-5	13	10	6	5	8	6	3	2.5
30	50	0	-12	0	-10	0	-8	0	-6	15	13	8	6	9	8	4	3
50	80	0	-15	0	-12	0	-9	0	-7	19	15	9	7	11	9	5	3.5
80	120	0	-20	0	-15	0	-10	0	-8	25	19	10	8	15	11	5	4
120	150	0	-25	0	-18	0	-13	0	-10	31	23	13	10	19	14	7	5
150	180	0	-25	0	-18	0	-13	0	-10	31	23	13	10	19	14	7	5
180	250	0	-30	0	-22	0	-15	0	-12	38	28	15	12	23	17	8	6
250	315	0	-35	0	-25	0	-18	—	—	44	31	18	—	26	19	9	—

1) 2.5 mm is included in this dimension group

Table-9 Accuracy of outer ring

D Nominal bearing outside diameter (mm)		Δ_{Dmp} Deviation of mean outside diameter in a single plane								V_{Dsp} Variation of outside diameter in a single plane				V_{Dmp} Variation of mean outside diameter in a single plane			
		0		6		5		4		0	6	5	4	0	6	5	4
Over	Incl.	high	low	high	low	high	low	high	low	max.				max.			
2.5 ²⁾	6	0	-8	0	-7	0	-5	0	-4	10	9	5	4	6	5	3	2
6	18	0	-8	0	-7	0	-5	0	-4	10	9	5	4	6	5	3	2
18	30	0	-9	0	-8	0	-6	0	-5	12	10	6	5	7	6	3	2.5
30	50	0	-11	0	-9	0	-7	0	-6	14	11	7	6	8	7	4	3
50	80	0	-13	0	-11	0	-9	0	-7	16	14	9	7	10	8	5	3.5
80	120	0	-15	0	-13	0	-10	0	-8	19	16	10	8	11	10	5	4
120	150	0	-18	0	-15	0	-11	0	-9	23	19	11	9	14	11	6	5
150	180	0	-25	0	-18	0	-13	0	-10	31	23	13	10	19	14	7	5
180	250	0	-30	0	-20	0	-15	0	-11	38	25	15	11	23	15	8	6
250	315	0	-35	0	-25	0	-18	0	-13	44	31	18	13	26	19	9	7

2) 2.5 mm is included in this dimension group

Unit: μm

K_{ia} Radial runout of inner ring of assembled bearing				S_d Reference face runout with bore (Inner ring)		Δ_{Bs} Deviation of a single inner ring width				V_{Bs} Variation of inner rings width				d Nominal bearing bore diameter (mm)	
0	6	5	4	5	4	0, 6		5, 4		0	6	5	4	Over	Incl.
max.				max.		high	low	high	low	max.					
10	6	4	2.5	7	3	0	-120	0	-40	15	15	5	2.5	2.5 ¹⁾	10
10	7	4	2.5	7	3	0	-120	0	-80	20	20	5	2.5	10	18
13	8	4	3	8	4	0	-120	0	-120	20	20	5	2.5	18	30
15	10	5	4	8	4	0	-120	0	-120	20	20	5	3	30	50
20	10	5	4	8	5	0	-150	0	-150	25	25	6	4	50	80
25	13	6	5	9	5	0	-200	0	-200	25	25	7	4	80	120
30	18	8	6	10	6	0	-250	0	-250	30	30	8	5	120	150
30	18	8	6	10	6	0	-250	0	-250	30	30	8	5	150	180
40	20	10	8	11	7	0	-300	0	-300	30	30	10	6	180	250
50	25	13	—	13	—	0	-350	0	-350	35	35	13	—	250	315

Unit: μm

K_{ea} Radial runout of outer ring of assembled bearing				S_D Variation of outside surface generatrix inclination with face (outer ring)		Δ_{Cs} Deviation of a single outer ring width		V_{Cs} Variation of outer ring width				D Nominal bearing outside diameter (mm)	
0	6	5	4	5	4	0, 6, 5, 4		0	6	5	4	Over	Incl.
max.				max.		high	low	max.					
15	8	5	3	8	4	Depending on tolerance of Δ_{Bs} for D of the same bearing.		Depending on tolerance of V_{Bs} for D of the same bearing.	5	2.5	2.5 ²⁾	6	
15	8	5	3	8	4				5	2.5	6	18	
15	9	6	4	8	4				5	2.5	18	30	
20	10	7	5	8	4				5	2.5	30	50	
25	13	8	5	8	4				6	3	50	80	
35	18	10	6	9	5				8	4	80	120	
40	20	11	7	10	5				8	5	120	150	
45	23	13	8	10	5				8	5	150	180	
50	25	15	10	11	7				10	7	180	250	
60	30	18	11	13	8				11	7	250	315	

Table-10 Permissive tolerance of chamfer

Unit: mm

r_s min	d Nominal bearing bore diameter		Radial direction	Axial direction
	Over	Incl.	r_s max	
0.15	—	—	0.3	0.6
0.2	—	—	0.5	0.8
0.3	— 40	40 —	0.6 0.8	1 1
0.6	— 40	40 —	1 1.3	2 2
1	— 50	50 —	1.5 1.9	3 3
1.1	— 120	120 —	2 2.5	3.5 4
1.5	— 120	120 —	2.3 3	4 5
2	— 80 220	80 220 —	3 3.5 3.8	4.5 5 6
2.1	— 280	280 —	4 4.5	6.5 7
2.5	— 100 280	100 280 —	3.8 4.5 5	6 6 7
3	— 280	280 —	5 5.5	8 8
4	—	—	6.5	9

* Remark Although no particular shape is specified for chamfer surface, its outline in axial plane must be within virtual arc of r_s min radius that is tangent to slope of inner ring and inner diameter face of bearing, or tangent to side of outer ring and bearing outer diameter. (Reference diagram)

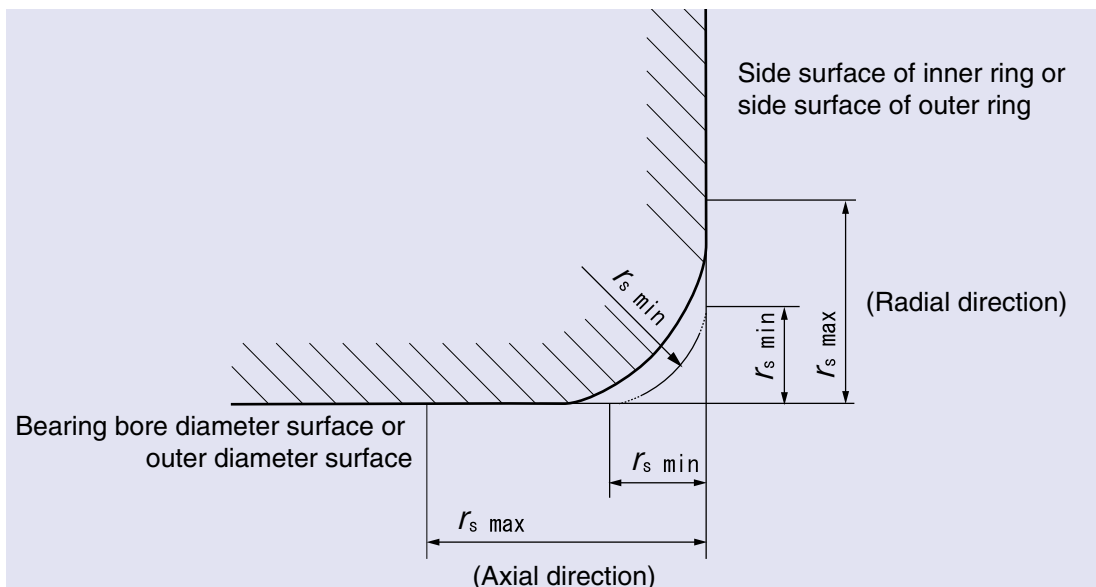

Table-11 Tolerance of minimum value of diameter of inscribed circle to roller

Unit: μm

Fw (mm) Inscribed circle diameter		Dimension difference of Δ Fw min Variation of minimum value of diameter of inscribed circle to roller	
Over	Incl.	high	low
3	6	+18	+10
6	10	+22	+13
10	18	+27	+16
18	30	+33	+20
30	50	+41	+25
50	80	+49	+30
80	120	+58	+36
120	180	+68	+43
180	250	+79	+50
250	315	+88	+56

This means diameter of roller that achieves zero radial clearance in at least one radial direction in the case of using cylindrical roller instead of bearing inner ring.

3-2 Measurement method

Measurement of single bore diameter

Table-12 Bearing bore diameter

Type and definition of accuracy	
d_{mp} Mean bore diameter in a single plane	Arithmetic mean of maximum and minimum value of the single bore diameters in a single radial plane. $d_{mp} = \frac{d_{sp\ max} + d_{sp\ min}}{2}$ d_{sp} : Single inner diameter in a particular radial plane.
Δ_{dmp} Deviation of mean bore diameter in a single plane	Difference between the mean bore diameter and nominal more diameter. $\Delta_{dmp} = d_{dmp} - d$ d : Nominal bearing bore diameter.
V_{dsp} Variation of single bore diameter in a single plane	Difference between maximum and minimum value of single bore diameter in single radial plane. $V_{dsp} = d_{sp\ max} - d_{sp\ min}$
V_{dmp} Variation of mean bore diameter in a single plane	Difference between maximum and minimum value of the mean bore diameter in a single plane in individual track ring basically with cylindrical inner diameter face. $V_{dmp} = d_{mp\ max} - d_{mp\ min}$
Δ_{ds} deviation of single bore diameter	Difference between single bore diameter and nominal bore diameter. $\Delta_{ds} = d_s - d$ d_s : Distance between two parallel straight lines which are tangent to intersecting line of actual bore diameter face and radial plane.

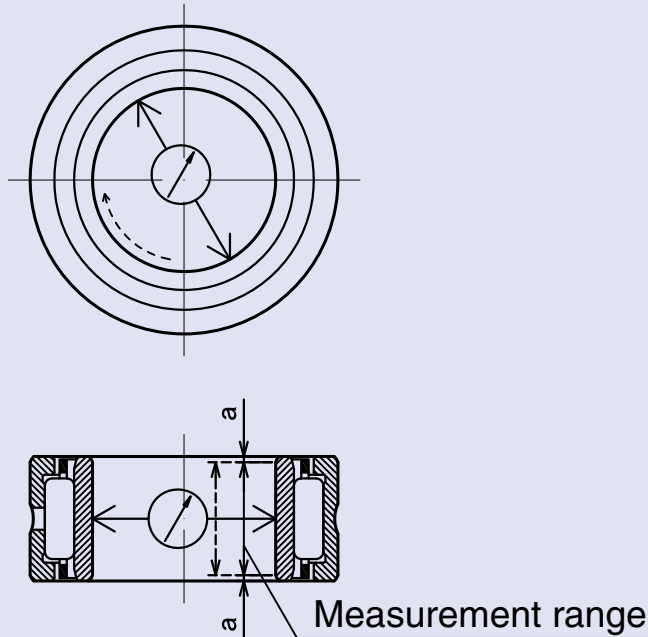

Method of measurement of bearing bore diameter

Zero the gauge indicator to the appropriate size using gauge blocks or a master ring.

In several angular directions and in a single radial plane, measure and record the largest and the smallest single bore diameters, $d_{sp\ max}$ and $d_{sp\ min}$.

Repeat angular measurements and recordings in several radial planes to determine the largest and the smallest single bore diameter of an individual ring, $d_{s\ max}$ and $d_{s\ min}$.

Table-13 Measurement area limit Unit: mm

r s min		a
Over	or less	
-	0.6	$r_{s\ max} + 0.5$
0.6	-	$1.2 \times r_{s\ max}$

Measurement of single outside diameter

Table-14 Bearing outer diameter

Type and definition of accuracy	
D_{mp} mean outside diameter in a single plane	Arithmetic mean of maximum and minimum value of the single outside diameters in a single radial plane. $D_{mp} = \frac{D_{sp\ max} + D_{sp\ min}}{2}$ D_{sp} : Single outside diameter in a particular radial plane
Δ_{Dmp} Deviation of mean outside diameter in a single plane	Difference between the mean outside diameter in a single plane of cylindrical outside diameter face and nominal outside diameter. $\Delta_{Dmp} = D_{mp} - D$ D : Nominal bearing outside diameter.
V_{Dsp} deviation of single outside diameter	Difference between maximum and minimum value of the mean outside diameter in a single radial plane. $V_{Dsp} = D_{sp\ max} - D_{sp\ min}$
V_{Dmp} Variation of mean outside diameter in a single plane	Difference between maximum and minimum value of the mean outside diameter in a single plane in individual track ring with basically cylindrical outer diameter face. $V_{Dmp} = D_{mp\ max} - D_{mp\ min}$
Δ_{Ds} deviation of single bore diameter	Difference between single outside diameter in basically cylindrical outside diameter face and nominal outside diameter. $\Delta_{Ds} = D_s - D$ D_s : Distance between two parallel straight lines which are tangent to intersecting line of actual outer diameter face and radial plane.

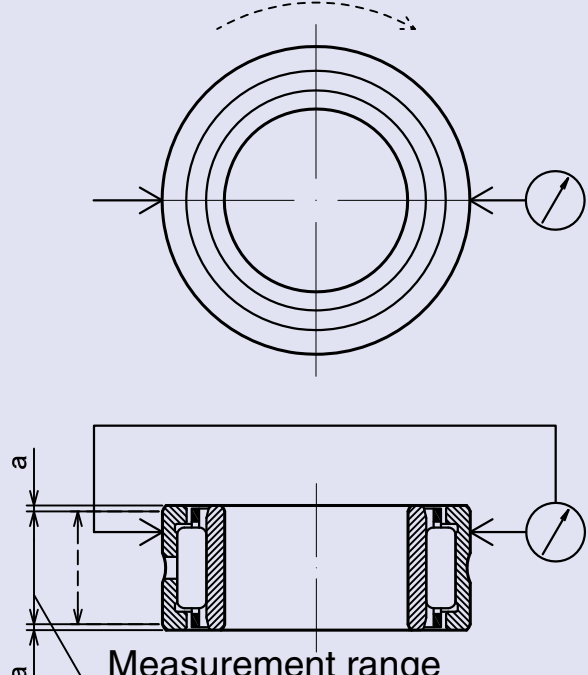

Method of measurement of bearing outer diameter

Zero the gauge indicator to the appropriate size using gauge blocks or a master.

In several angular directions and in a single radial plane, measure and record the largest and the smallest single outside diameters, $D_{sp\ max}$ and $D_{sp\ min}$.

Repeat and record measurements in several radial planes to determine the largest and the smallest single outside diameter of an individual ring, $D_{s\ max}$ and $D_{s\ min}$.

Measurement of single bore diameter of rolling element complement

Table-15 Measurement of single bore diameter of rolling element complement

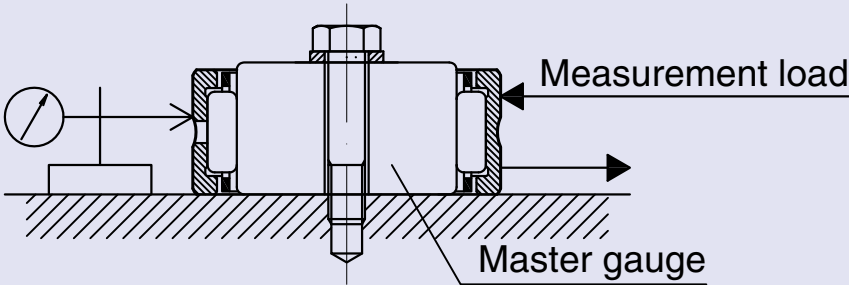
Type and definition of accuracy	
F_{ws} Nominal bore diameter of rolling element complement	Distance between two parallel straight lines which are tangent to intersecting line of inscribed circle of rolling element complement and radial plane in radial bearing without inner ring.
$F_{ws\ min}$ Minimum nominal bore diameter of rolling element complement	Minimum nominal bore diameter of rolling element complement in radial bearing without inner ring. Remark Minimum nominal bore diameter of rolling element complement is diameter of cylinder whose radial clearance becomes zero in at least one radial direction.
 <p>Measurement of single bore diameter of rolling element complement</p>	

Fasten the master gauge to a surface plate.

Position the bearing on the master gauge and apply the indicator in the radial direction to the approximate middle of the width on the ring outside surface.

Measure the amount of movement of the outer ring in the radial direction by applying sufficient load on the outer ring in the same radial direction as that of the indicator and in the opposite radial direction.

Record indicator readings at the extreme radial positions of the outer ring. Rotate the bearing and repeat the measurement in several different angular positions to determine the largest and the smallest readings, $F_{ws\ max}$ and $F_{ws\ min}$.

Table-16 Radial measurement load

F_w mm		Measurement load N
Over	Incl.	min.
—	30	50
30	50	60
50	80	70
80	—	80

Measurement of single inner ring width (or outer ring width)

Table-17 Measurement of single inner ring width (or outer ring width)

Type and definition of accuracy	
Δ_{B_s} Deviation of single inner ring width	Difference between single inner ring width and nominal inner ring width. $\Delta_{B_s} = B_s - B$
V_{B_s} Variation of inner ring width	Difference between maximum and minimum value of the single bore diameter width in each inner ring. $V_{B_s} = B_{s\max} - B_{s\min}$
Δ_{C_s} Deviation of single outer ring width	Difference between single outer ring width and nominal outer ring width $\Delta_{C_s} = C_s - C$
V_{C_s} Variation of outer ring width	Difference between maximum and minimum value of the single outer ring width in each outer ring. $V_{C_s} = C_{s\max} - C_{s\min}$

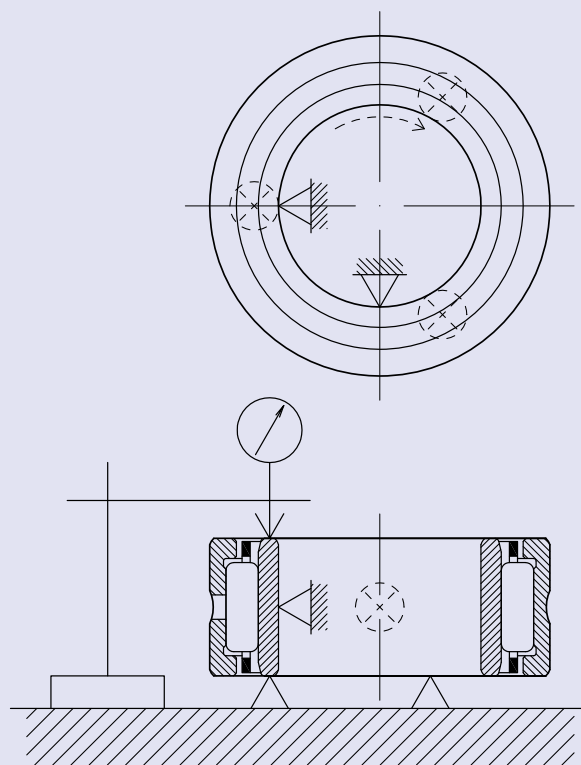

Measurement of single inner ring width (or outer ring width)

Zero the gauge indicator to the appropriate height from the reference surface using gauge blocks or a master.

Support one face of the ring on three equally spaced fixed supports of equal height and provide two suitable radial supports on the bore surface set at 90° to each other to center the ring.

Position the indicator against the other face of the ring opposite one fixed support.

Rotate the ring one revolution and measure and record the largest and the smallest single ring width, $B_{s\max}$ and $B_{s\min}$ ($C_{s\max}$ and $C_{s\min}$).

Measurement of perpendicularity of inner ring face with respect to the bore (S_d)

Use a precision arbor having a taper of approximately 1:5000 on diameter.

Mount the bearing assembly on the tapered arbor and place the arbor between two centres so that it can be accurately rotated.

Position the indicator against the reference face of the inner ring at a radial distance from the arbor axis of half the mean diameter of the face.

Take indicator readings while rotating the inner ring one revolution.

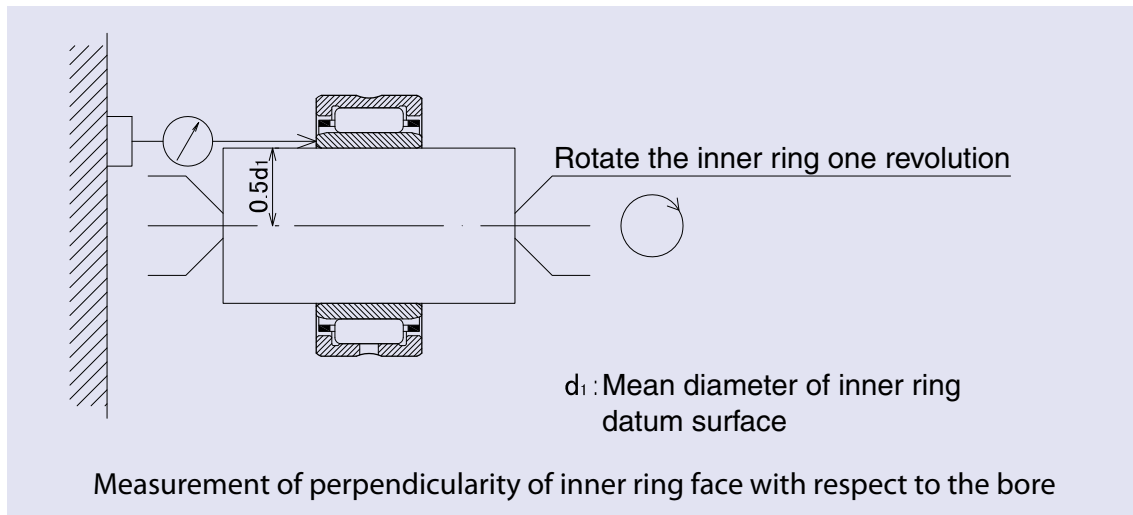

Measurement of perpendicularity of outer ring outside surface with respect to the face (S_D)

Support the reference face of the outer ring on a surface plate leaving the inner ring, if an assembled bearing, free. Locate the outer ring cylindrical outside surface against two supports set at 90° to each other to centre the outer ring.

Position the indicator directly above one support. The indicator and the two supports are axially located at the extremes of the measurement zone.

Take indicator readings while rotating the outer ring one revolution.

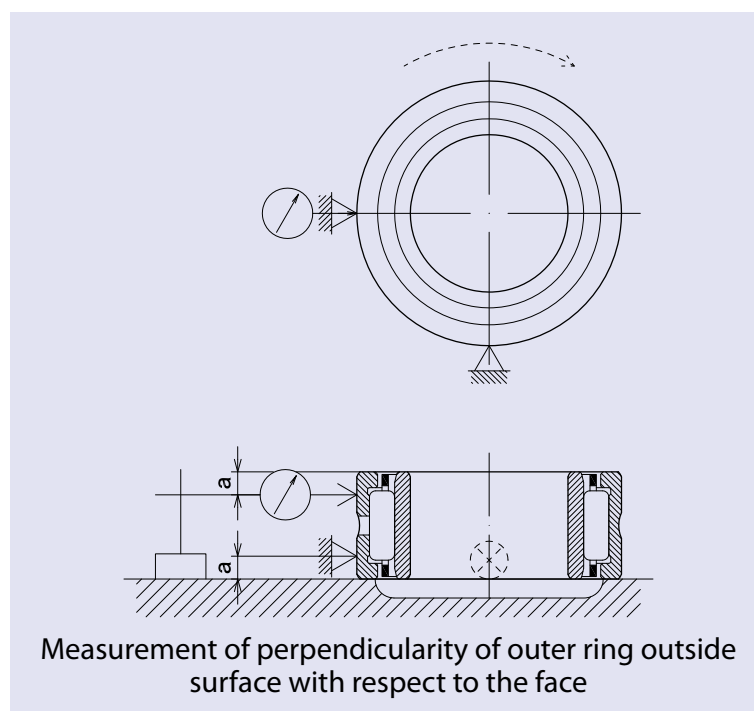

Measurement of radial runout of inner ring (K_{ia})

Use a precision arbor having a taper of approximately 1:5000 on diameter.

Mount the bearing assembly on the tapered arbor and place the arbor between two centres so that it can be accurately rotated.

Position the indicator against the outside surface of the outer ring as close as possible to the middle of the outer ring raceway.

Hold the outer ring to prevent rotation but ensure its weight is supported by the rolling elements. Take indicator readings while rotating the arbor one revolution.

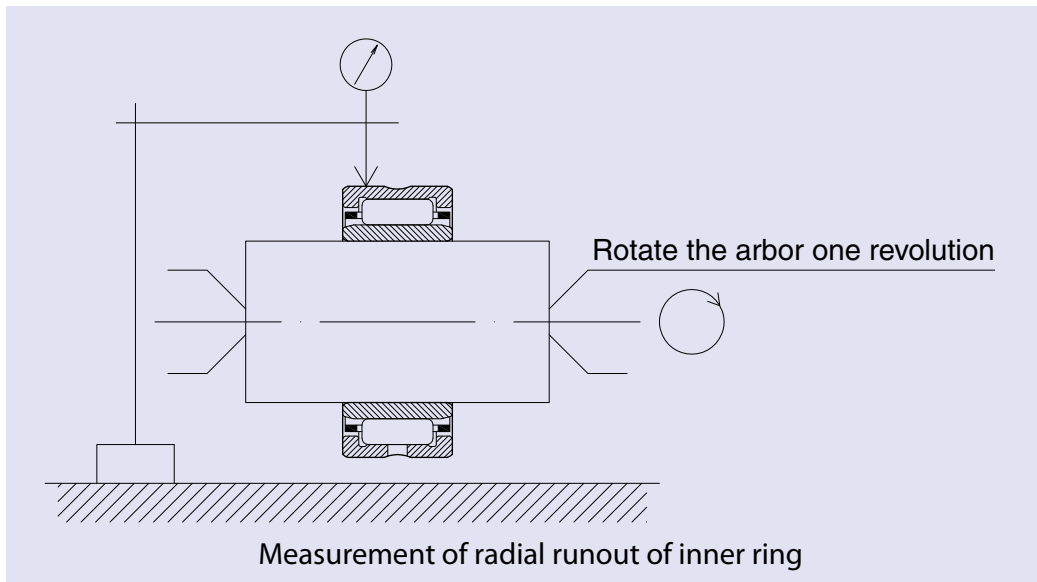

Measurement of radial runout of outer ring (K_{ea})

Use a precision arbor having a taper of approximately 1:5000 on diameter.

Mount the bearing assembly on the tapered arbor and place the arbor between two centres so that it can be accurately rotated.

Position the indicator against the outside surface of the outer ring as close as possible to the middle of the outer ring raceway.

Hold the inner ring stationary. Take indicator readings while rotating the outer ring one revolution.

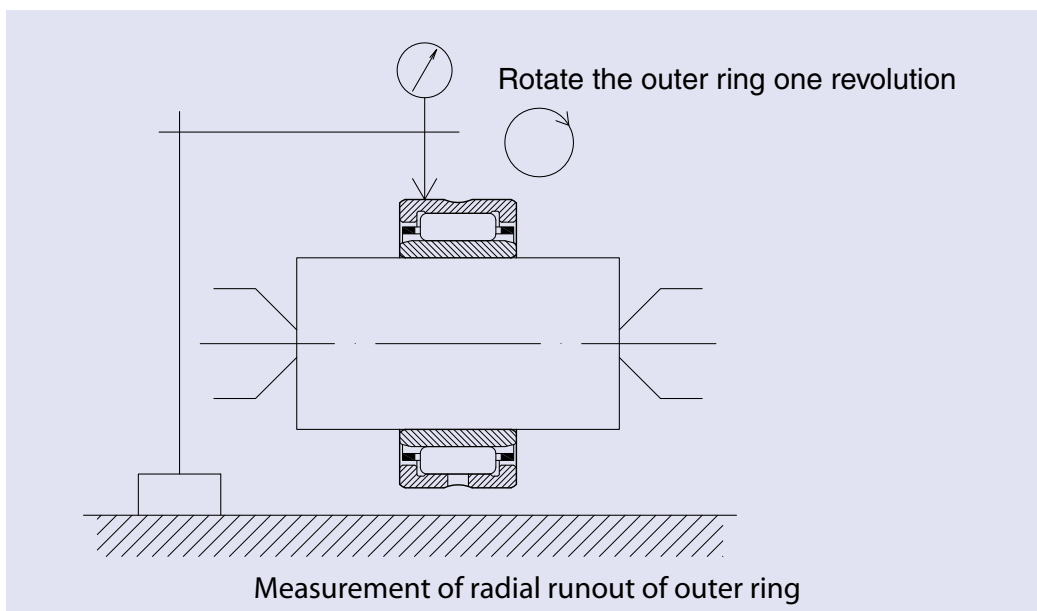

4 Internal clearance of bearing

4-1 Radial internal clearance of bearing

Radial internal clearance of bearing means a displacement of either inner ring or outer ring, which is free side, when the specified measurement load is applied to it alternatively in radial direction while locking the opposite component in the condition before mounting the bearing on shaft or housing. This measurement loads are quite small and they are specified in JIS B 1515:2006 (Rolling bearings - Tolerances). Radial internal clearance of needle bearing with inner ring is specified in JIS B 1520:1995 (radial internal clearance of bearing). Clearances shown in Table-18 are categorized in group C2, CN, C3, C4, C5 starting from smaller clearance and group CN is applied to general application.

■ Radial internal clearance of bearing

Table-18 Internal clearance of radial bearing

Category	Description
C2	Radial clearance smaller than standard clearance
CN clearance	Standard radial clearance
C3, C4, C5	Radial clearance larger than standard clearance

Table-19 Value of radial internal clearance of needle bearing

Unit: μm

d Nominal bearing bore diameter (mm)		Clearance category									
		C2		CN		C3		C4		C5	
Over	Incl.	min.	max.	min.	max.	min.	max.	min.	max.	min.	max.
-	10	0	25	20	45	35	60	50	75	-	-
10	24	0	25	20	45	35	60	50	75	65	90
24	30	0	25	20	45	35	60	50	75	70	95
30	40	5	30	25	50	45	70	60	85	80	105
40	50	5	35	30	60	50	80	70	100	95	125
50	65	10	40	40	70	60	90	80	110	110	140
65	80	10	45	40	75	65	100	90	125	130	165
80	100	15	50	50	85	75	110	105	140	155	190
100	120	15	55	50	90	85	125	125	165	180	220
120	140	15	60	60	105	100	145	145	190	200	245
140	160	20	70	70	120	115	165	165	215	225	275
160	180	25	75	75	125	120	170	170	220	250	300
180	200	35	90	90	145	140	195	195	250	275	330
200	225	45	105	105	165	160	220	220	280	305	365
225	250	45	110	110	175	170	235	235	300	330	395

Remark Nominal number C2,C3,C4 are displayed as part code suffix for these bearings (excluding CN clearance). Example) NA 4903 C2

4-2 Selection of radial internal clearance of bearing

Selection of clearance

Radial internal clearance of needle bearing in operation may generally become smaller than initial radial internal clearance. Temperature difference between inner and outer bearing during operation and fit cause this change. The radial internal clearance has a significant impact to life, vibration and heat generation of bearing.

Typically, larger radial internal clearance causes increase of vibration and smaller one results in heat generation or reduction of life due to excessive force between rolling element and track. Initial radial internal clearance may be selected as slightly larger than zero clearance in consideration for the internal clearance during operation. Bearing is designed to have suitable radial clearance by selecting CN clearance for general application.

Reduction of radial internal clearance due to fits

When bearing is installed to shaft or housing, radial internal clearance reduces due to expansion or shrinking of track with elastic deformation.

Reduction of radial clearance due to temperature difference between inner and outer ring

Friction heat generated by rotation of bearing will be released to outside through shaft and/or housing. In general application, radial internal clearance may be reduced as much as the difference of amount of thermal expansion between inner and outer ring since outer ring becomes cooler than inner ring due to larger heat release from housing than that from shaft.

5 Fits

5-1 Purpose of fits

Purpose of "fits" for a bearing is to fixate a bearing with sufficient "interference" between inner ring and shaft or between outer ring and housing. Insufficient "fits" may cause harmful phenomena which result in damaging bearing or shortening its life such as abnormal wear in fitting surface, abnormal heat by abrasion powder, abnormal rotation and vibration due to slip of fitting surface. Therefore, it is imperative to select proper fits for application.

5-2 Selection of fits

Condition for selection of fits

Selection of bearing "fits" needs to consider following points. Properties and size of load in application, condition of temperature, accuracy of rotation, material, finish, wall thickness of shaft and housing and easiness of assembling/disassembling.

"Fits" as shown in Table-20 is generally determined based on properties of load and condition of rotation.

Table-20 Properties of radial load and fits

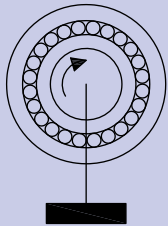
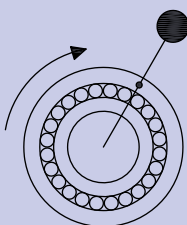
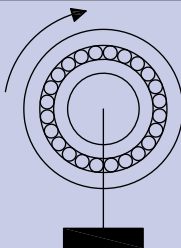
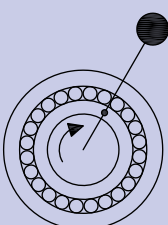
Properties of bearing load			Fits	
			Inner ring	Outer ring
Load with rotating inner ring Load with stationary outer ring		Inner ring: rotation Outer ring: stationary Loading direction: constant	Tight fit	Loose fit
		Inner ring: stationary Outer ring: rotation Loading direction: rotate together with outer ring		
Load with rotating outer ring Load with stationary inner ring		Inner ring: stationary Outer ring: rotation Loading direction: constant	Loose fit	Tight fit
		Inner ring: rotation Outer ring: stationary Loading direction: rotate together with inner ring		
Load in inconsistent direction	Direction of load is inconsistent due to varying load direction or including unbalanced load	Inner ring: rotation or stationary Outer ring: rotation or stationary Loading direction: inconsistent	Tight fit	Tight fit

Selection of fits

It is necessary to take condition of temperature and material of shaft and housing into consideration in addition to properties of load and rotation condition for selection of "fits" as mentioned above. Yet, it is common practice to determine "fits" based on reference to experience and past record because of difficulty for recognizing whole conditions. Table-21 and Table-22 show "fits" for general application and Table-23 shows "fits" for needle bearing without inner ring against shaft.

Table-21 Fits between needle bearing and housing hole

Conditions		Tolerance grade for housing
Load with stationary outer ring	Standard and heavy load	J7
	Split housing with standard load	H7
Load in inconsistent direction	Light load	J7
	Standard load	K7
	Heavy load and impact shock load	M7
Load with rotating outer ring	Light load	M7
	Standard load	N7
	Heavy load and impact shock load	P7
Light load and high rotation accuracy		K6

Table-22 Fits between needle bearing with inner ring and shaft

Conditions		Shaft diameter (mm)		Tolerance grade
		Over	Incl.	
Load with rotating inner ring or Load in inconsistent direction	Light load	—	50	j5
		50	100	k5
	Standard load	—	50	k5
		50	150	m5·m6
		150~		m6·n6
		~150		m6·n6
Heavy load and impact shock load	150~		n6·p6	
	All dimension		g6	
Load with stationary inner ring	Mid to low speed, light load	All dimension		h6
	Mid to low speed, standard load or heavy load	All dimension		h6
	With precision rotation accuracy	All dimension		h5

Remark Light load $P_r \leq 0.06C_r$, Standard load $0.06C_r < P_r \leq 0.12C_r$, Heavy load $P_r > 0.12C_r$,
 P_r : Dynamic equivalent radial load C_r : Basic dynamic load rating

Table-23 Fits between needle bearing without inner ring and shaft

Nominal diameter of inscribed circle F_w (mm)		Radial internal clearance		
		Clearance smaller than CN clearance	CN clearance	Clearance larger than CN clearance
Over	Incl.	Tolerance group grade for shaft		
-	65	k5	h5	g6
65	80	k5	h5	f6
80	160	k5	g5	f6
160	180	k5	g5	e6
180	200	j5	g5	e6
200	250	j5	f6	e6
250	315	h5	f6	e6

Remark Tight fit with housing hole smaller than k7 shall be modified with smaller shaft size in considering diameter shrink of inscribed circle of roller after assembly.

5-3 Table for shaft and housing fits

Table-24 Tolerances for shafts

Nominal bearing bore diameter and nominal diameter of shaft d (mm)		Tolerance grade for shaft																															
		b12		c12		d6		e6		e7		f5		f6		g5		g6		h5		h6		h7		h8		h9		h10		h11	
Over	Incl.	high	low	high	low	high	low	high	low	high	low	high	low	high	low	high	low	high	low	high	low	high	low	high	low	high	low	high	low	high	low		
—	3	-140	-240	-60	-160	-20	-26	-14	-20	-14	-24	-6	-10	-6	-12	-2	-6	-2	-8	0	-4	0	-6	0	-10	0	-14	0	-25	0	-40	0	-60
3	6	-140	-260	-70	-190	-30	-38	-20	-28	-20	-32	-10	-15	-10	-18	-4	-9	-4	-12	0	-5	0	-8	0	-12	0	-18	0	-30	0	-48	0	-75
6	10	-150	-300	-80	-230	-40	-49	-25	-34	-25	-40	-13	-19	-13	-22	-5	-11	-5	-14	0	-6	0	-9	0	-15	0	-22	0	-36	0	-58	0	-90
10	18	-150	-330	-95	-275	-50	-61	-32	-43	-32	-50	-16	-24	-16	-27	-6	-14	-6	-17	0	-8	0	-11	0	-18	0	-27	0	-43	0	-70	0	-110
18	30	-160	-370	-110	-320	-65	-78	-40	-53	-40	-61	-20	-29	-20	-33	-7	-16	-7	-20	0	-9	0	-13	0	-21	0	-33	0	-52	0	-84	0	-130
30	40	-170	-420	-120	-370	-80	-96	-50	-66	-50	-75	-25	-36	-25	-41	-9	-20	-9	-25	0	-11	0	-16	0	-25	0	-39	0	-62	0	-100	0	-160
40	50	-180	-430	-130	-380																												
50	65	-190	-490	-140	-440	-100	-119	-60	-79	-60	-90	-30	-43	-30	-49	-10	-23	-10	-29	0	-13	0	-19	0	-30	0	-46	0	-74	0	-120	0	-190
65	80	-200	-500	-150	-450																												
80	100	-220	-570	-170	-520	-120	-142	-72	-94	-72	-107	-36	-51	-36	-58	-12	-27	-12	-34	0	-15	0	-22	0	-35	0	-54	0	-87	0	-140	0	-220
100	120	-240	-590	-180	-530																												
120	140	-260	-660	-200	-600	-145	-170	-85	-110	-85	-125	-43	-61	-43	-68	-14	-32	-14	-39	0	-18	0	-25	0	-40	0	-63	0	-100	0	-160	0	-250
140	160	-280	-680	-210	-610																												
160	180	-310	-710	-230	-630	-170	-199	-100	-129	-100	-146	-50	-70	-50	-79	-15	-35	-15	-44	0	-20	0	-29	0	-46	0	-72	0	-115	0	-185	0	-290
180	200	-340	-800	-240	-700																												
200	225	-380	-840	-260	-720	-190	-222	-110	-142	-110	-162	-56	-79	-56	-88	-17	-40	-17	-49	0	-23	0	-32	0	-52	0	-81	0	-130	0	-210	0	-320
225	250	-420	-880	-280	-740																												
250	280	-480	-1000	-300	-820	-190	-222	-110	-142	-110	-162	-56	-79	-56	-88	-17	-40	-17	-49	0	-23	0	-32	0	-52	0	-81	0	-130	0	-210	0	-320
280	315	-540	-1060	-330	-850																												

Table-25 Tolerances for holes

Nominal bearing outer diameter and nominal diameter of hole D(mm)		Housing tolerances and resulting fits																													
		B12		E7		E8		E9		F6		F7		G6		G7		H6		H7		H8		H9		H10		H11			
Over	Incl.	high	low	high	low	high	low	high	low	high	low	high	low	high	low	high	low	high	low	high	low	high	low	high	low	high	low	high	low	high	low
—	3	+240	+140	+24	+14	+28	+14	+39	+14	+12	+6	+16	+6	+8	+2	+12	+2	+6	0	+10	0	+14	0	+25	0	+40	0	+60	0		
3	6	+260	+140	+32	+20	+38	+20	+50	+20	+18	+10	+22	+10	+12	+4	+16	+4	+8	0	+12	0	+18	0	+30	0	+48	0	+75	0		
6	10	+300	+150	+40	+25	+47	+25	+61	+25	+22	+13	+28	+13	+14	+5	+20	+5	+9	0	+15	0	+22	0	+36	0	+58	0	+90	0		
10	18	+330	+150	+50	+32	+59	+32	+75	+32	+27	+16	+34	+16	+17	+6	+24	+6	+11	0	+18	0	+27	0	+43	0	+70	0	+110	0		
18	30	+370	+160	+61	+40	+73	+40	+92	+40	+33	+20	+41	+20	+20	+7	+28	+7	+13	0	+21	0	+33	0	+52	0	+84	0	+130	0		
30	40	+420	+170	+75	+50	+89	+50	+112	+50	+41	+25	+50	+25	+25	+9	+34	+9	+16	0	+25	0	+39	0	+62	0	+100	0	+160	0		
40	50	+430	+180																												
50	65	+490	+190	+90	+60	+106	+60	+134	+60	+49	+30	+60	+30	+29	+10	+40	+10	+19	0	+30	0	+46	0	+74	0	+120	0	+190	0		
65	80	+500	+200																												
80	100	+570	+220	+107	+72	+126	+72	+159	+72	+58	+36	+71	+36	+34	+12	+47	+12	+22	0	+35	0	+54	0	+87	0	+140	0	+220	0		
100	120	+590	+240																												
120	140	+660	+260	+125	+85	+148	+85	+185	+85	+68	+43	+83	+43	+39	+14	+54	+14	+25	0	+40	0	+63	0	+100	0	+160	0	+250	0		
140	160	+680	+280																												
160	180	+710	+310	+146	+100	+172	+100	+215	+100	+79	+50	+96	+50	+44	+15	+61	+15	+29	0	+46	0	+72	0	+115	0	+185	0	+290	0		
180	200	+800	+340																												
200	225	+840	+380	+162	+110	+191	+110	+240	+110	+88	+56	+108	+56	+49	+17	+69	+17	+32	0	+52	0	+81	0	+130	0	+210	0	+320	0		
225	250	+880	+420																												
250	280	+1000	+480	+162	+110	+191	+110	+240	+110	+88	+56	+108	+56	+49	+17	+69	+17	+32	0	+52	0	+81	0	+130	0	+210	0	+320	0		
280	315	+1060	+540																												

Unit: μm

Tolerance grade for shaft																								Nominal bearing bore diameter and nominal diameter of shaft d (mm)			
h12		js5		j5		js6		j6		j7		k5		k6		m5		m6		n5		n6				p6	
high	low	high	low	high	low	high	low	high	low	high	low	high	low	high	low	high	low	high	low	high	low	high	low	high	low	Over	Incl.
0	-100	+2	-2	+2	-2	+3	-3	+4	-2	+6	-4	+4	0	+6	0	+6	+2	+8	+2	+8	+4	+10	+4	+12	+6	—	3
0	-120	+2.5	-2.5	+3	-2	+4	-4	+6	-2	+8	-4	+6	+1	+9	+1	+9	+4	+12	+4	+13	+8	+16	+8	+20	+12	3	6
0	-150	+3	-3	+4	-2	+4.5	-4.5	+7	-2	+10	-5	+7	+1	+10	+1	+12	+6	+15	+6	+16	+10	+19	+10	+24	+15	6	10
0	-180	+4	-4	+5	-3	+5.5	-5.5	+8	-3	+12	-6	+9	+1	+12	+1	+15	+7	+18	+7	+20	+12	+23	+12	+29	+18	10	18
0	-210	+4.5	-4.5	+5	-4	+6.5	-6.5	+9	-4	+13	-8	+11	+2	+15	+2	+17	+8	+21	+8	+24	+15	+28	+15	+35	+22	18	30
0	-250	+5.5	-5.5	+6	-5	+8	-8	+11	-5	+15	-10	+13	+2	+18	+2	+20	+9	+25	+9	+28	+17	+33	+17	+42	+26	30	40
																										40	50
0	-300	+6.5	-6.5	+6	-7	+9.5	-9.5	+12	-7	+18	-12	+15	+2	+21	+2	+24	+11	+30	+11	+33	+20	+39	+20	+51	+32	50	65
																										65	80
0	-350	+7.5	-7.5	+6	-9	+11	-11	+13	-9	+20	-15	+18	+3	+25	+3	+28	+13	+35	+13	+38	+23	+45	+23	+59	+37	80	100
																										100	120
0	-400	+9	-9	+7	-11	+12.5	-12.5	+14	-11	+22	-18	+21	+3	+28	+3	+33	+15	+40	+15	+45	+27	+52	+27	+68	+43	120	140
																										140	160
																										160	180
0	-460	+10	-10	+7	-13	+14.5	-14.5	+16	-13	+25	-21	+24	+4	+33	+4	+37	+17	+46	+17	+51	+31	+60	+31	+79	+50	180	200
																										200	225
																										225	250
0	-520	+11.5	-11.5	+7	-16	+16	-16	+16	-16	+26	-26	+27	+4	+36	+4	+43	+20	+52	+20	+57	+34	+66	+34	+88	+56	250	280
																										280	315

Unit: μm

Housing tolerances and resulting fits																								Nominal bearing outer diameter and nominal diameter of hole d (mm)									
JS6		J6		JS7		J7		K5		K6		K7		M6		M7		N6		N7		P6				P7		R7		S7			
high	low	high	low	high	low	high	low	high	low	high	low	high	low	high	low	high	low	high	low	high	low	high	low	high	low	high	low	high	low	Over	Incl.		
+3	-3	+2	-4	+5	-5	+4	-6	0	-4	0	-6	0	-10	-2	-8	-2	-12	-4	-10	-4	-14	-6	-12	-6	-16	-10	-20	-14	-24	—	3		
+4	-4	+5	-3	+6	-6	+6	-6	0	-5	+2	-6	+3	-9	-1	-9	0	-12	-5	-13	-4	-16	-9	-17	-8	-20	-11	-23	-15	-27	3	6		
+4.5	-4.5	+5	-4	+7.5	-7.5	+8	-7	+1	-5	+2	-7	+5	-10	-3	-12	0	-15	-7	-16	-4	-19	-12	-21	-9	-24	-13	-28	-17	-32	6	10		
+5.5	-5.5	+6	-5	+9	-9	+10	-8	+2	-6	+2	-9	+6	-12	-4	-15	0	-18	-9	-20	-5	-23	-15	-26	-11	-29	-16	-34	-21	-39	10	18		
+6.5	-6.5	+8	-5	+10.5	-10.5	+12	-9	+1	-8	+2	-11	+6	-15	-4	-17	0	-21	-11	-24	-7	-28	-18	-31	-14	-35	-20	-41	-27	-48	18	30		
+8	-8	+10	-6	+12.5	-12.5	+14	-11	+2	-9	+3	-13	+7	-18	-4	-20	0	-25	-12	-28	-8	-33	-21	-37	-17	-42	-25	-50	-34	-59	30	40		
																														40	50		
+9.5	-9.5	+13	-6	+15	-15	+18	-12	+3	-10	+4	-15	+9	-21	-5	-24	0	-30	-14	-33	-9	-39	-26	-45	-21	-51	-30	-60	-42	-72	50	65		
																														65	80		
+11	-11	+16	-6	+17.5	-17.5	+22	-13	+2	-13	+4	-18	+10	-25	-6	-28	0	-35	-16	-38	-10	-45	-30	-52	-24	-59	-38	-73	-58	-93	80	100		
																														100	120		
+12.5	-12.5	+18	-7	+20	-20	+26	-14	+3	-15	+4	-21	+12	-28	-8	-33	0	-40	-20	-45	-12	-52	-36	-61	-28	-68	-48	-88	-77	-117	120	140		
																														140	160		
																														160	180		
+14.5	-14.5	+22	-7	+23	-23	+30	-16	+2	-18	+5	-24	+13	-33	-8	-37	0	-46	-22	-51	-14	-60	-41	-70	-33	-79	-60	-106	-105	-151	180	200		
																														200	225		
																														225	250		
+16	-16	+25	-7	+26	-26	+36	-16	+3	-20	+5	-27	+16	-36	-9	-41	0	-52	-25	-57	-14	-66	-47	-79	-36	-88	-74	-126	-138	-190	250	280		
																														280	315		

6 Design of shaft and housing

6-1 Accuracy of fitting surface

Correct design and manufacturing of shaft or housing to which needle bearing is assembled are vital for adequate bearing performance since the needle bearing has thinner track ring compared to other types of rolling bearings. Table-26 shows dimension accuracy and geometric accuracy of "fitting" part of shaft and housing in standard application condition, surface roughness and tolerance of runout of shoulder against fitting surface.

Table-26 Accuracy of shaft and housing (recommended)

Item	Shaft	Housing
Roundness tolerance	IT3~IT4	IT4~IT5
Cylindricity tolerance	IT3~IT4	IT4~IT5
Shoulder runout tolerance	IT3	IT3~IT4
Roughness of fitting surface	0.8a	1.6a

6-2 Accuracy of track surface

Needle bearing can be directly attached to shaft or housing as track for compact bearing structure. In this case, accuracy and roughness of track surface must be equivalent to that of bearing track surface in order to ensure bearing life with high rotation accuracy. Since accuracy and roughness of shaft and housing may affect life and the cause of abnormality of the bearing.

Table-27 shows specification for accuracy and roughness of track surface.

Table-27 Accuracy of track surface (recommended)

Item	Shaft	Housing
Roundness tolerance	IT3	IT3
Cylindricity tolerance	IT3	IT3
Shoulder runout tolerance	IT3	IT3
Surface roughness	0.2a	

6-3 Material and heat treatment of track surface

Surface hardness of shaft and housing must be HRC58 to 64 in order to obtain sufficient loading capacity in the case of using them as direct track surface. Table-28 shows recommended heat treatment for their material.

Table-28 Material for track

Type of steel	Representative example	Related standards
High carbon-chromium bearing steel	SUJ2	JIS G 4805
Chromium molybdenum steel	SCM415~435	JIS G 4053
Carbon tool steel	SK85	JIS G 4401
Stainless steel	SUS440C	JIS G 4303

6-4 Skew of bearing

Skew between inner ring and outer ring generated by deflection of shaft due to external force or mounting error may result in reduction of life caused by abnormal wear or heat. While permissive amount of skew varies depending on type of bearing, load and bearing internal clearance, it is recommended to be 1/2000 or less for general application.

6-5 Mounting dimension for bearing

Dimension of shaft and housing for mounting needle bearing (Figure-8) is shown in dimension table for respective bearings.

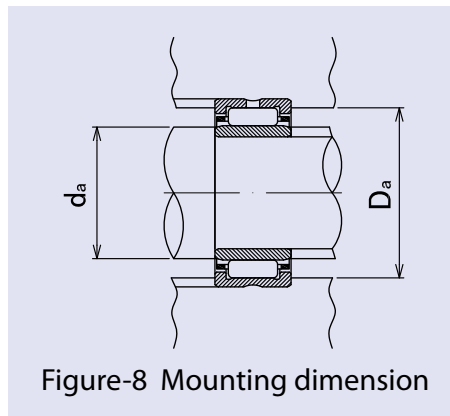

Fillet radius and height of shoulder for shaft and housing

Maximum permissive radius ($r_{as\ max}$) of fillet radius for shaft and housing to which needle bearings are assembled corresponds to minimum permissive chamfer dimension ($r_{s\ min}$) of the bearings.

Minimum value of shoulder diameter of the shaft (d_a) shall be nominal bore diameter (d) of bearing plus its shoulder height (h) multiplied by 2. Maximum value of shoulder diameter of the housing (D_a) shall be outer diameter (D) of bearing minus height of its shoulder multiplied by 2.

Table-29 Maximum permissive actual radius of corner R of shaft and housing $r_{as\ max}$

Unit: mm

$r_{s\ min}$ Minimum permissive chamfer dimension	$r_{as\ max}$ Maximum permissive actual radius of corner R of shaft and housing	<p>Height of shoulder and corner R</p>
0.1	0.1	
0.15	0.15	
0.2	0.2	
0.3	0.3	
0.4	0.4	
0.6	0.6	
1	1	
1.1	1	
1.5	1.5	
2	2	
2.1	2	
2.5	2	
3	2.5	
4	3	
5	4	

Table-30 Value of tolerance class IT for reference dimension

Unit: μm

Reference dimension mm		Tolerance class					
Over	Incl.	IT2	IT3	IT4	IT5	IT6	IT7
3	6	1.5	2.5	4	5	8	12
6	10	1.5	2.5	4	6	9	15
10	18	2	3	5	8	11	18
18	30	2.5	4	6	9	13	21
30	50	2.5	4	7	11	16	25
50	80	3	5	8	13	19	30
80	120	4	6	10	15	22	35
120	180	5	8	12	18	25	40
180	250	7	10	14	20	29	46
250	315	8	12	16	23	32	52

7 Lubrication

7-1 Purpose of lubrication

Purpose of bearing lubrication is to prevent its heat-seizure by mitigating friction and abrasion of rolling surface and slipping surface. Followings are the detailed explanation.

(1) Mitigation of friction and abrasion

It prevents direct contact between track, rolling element and cage.

It also mitigates friction and abrasion as a result of slip on track surface.

(2) Removal of frictional heat

Lubricant removes abrasion heat inside of bearing or heat propagated from outside to prevent excessive heat-up of the bearing.

(3) Extension of bearing life

Separating rolling element and track by oil film results in extension of bearing life.

(4) Prevention of rust

Oil film of lubricant mitigates oxidation inside and surface of bearing to prevent corrosion.

(5) Prevention of dust

Packed grease in the case of grease lubrication prevent invasion of foreign matter.

Efficient performance of these effects requires using lubrication method suitable for the application as well as selection of proper lubricant, its adequate amount, prevention against invasion of external foreign matter and optimal sealing structure in order to avoid leakage of the lubricant.

7-2 Comparison of grease and oil lubrication

Lubrication method

Lubrication method of bearing consists of grease lubrication and oil lubrication.

Grease lubrication is so popular for broad type of bearing because of its cost efficiency due to its simple sealing structure and a long duration of operating period with single filling. However, its disadvantage is larger flow resistance than oil lubrication in light of efficiency to large cooling capability and high speed application.

Oil lubrication has advantage in large cooling capability and high speed application due to its good flow characteristics. However, it demands design with consideration to sealing structure and leakage prevention.

The Table-31 compares the two lubrication methods as a guidance for lubrication method selection.

Table-31 Comparison of grease and oil lubrication

Item \ Lubrication method	Grease	Oil
Replacement of lubricant	△	○
Lubrication performance	○	◎
Cooling efficiency	×	○
Sealing structure	○	△
Power loss	△	○
Maintenance	○	△
High speed operation	×	○

7-3 Grease lubrication

Filling amount of grease

Grease shall be packed up to volume approximately one-third to one-half of internal space of bearing or housing. Excessive grease may cause degraded lubrication performance due to leakage of softened grease or oxidation as a result of increased temperature inside of bearing. This should be critical especially in high speed operation.

Figure-9 shows an example of grease replenishment plan from side way using a ring with grease hole. Arranging grease holes evenly on circumference of the ring allows simultaneous entry of replenished grease into bearing for replacing old grease with new one. However, this design also allows standing old grease in opposite side space, which needs to be removed periodically by removing the cover.

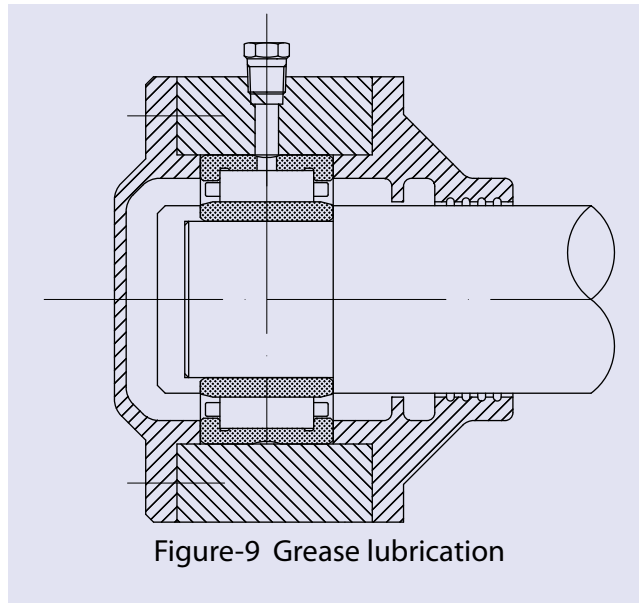

Lubrication grease

Grease is a semi-solid lubricant consisting of a base oil (liquid lubrication agent) and a thickener, which are combined on heating.

Table-32 Type and properties of grease (reference)

Name	Lithium grease			Sodium grease	Calcium base grease	Aluminum grease	Non-soap grease	
Thickener	Li soap			Na soap	Ca + Na soap Ca + Li soap	Al soap	Bentonite,urea,etc	
Base oil	Mineral oil	Diester oil	Silicon oil	Mineral oil	Mineral oil	Mineral oil	Mineral oil	Synthetic oil
Dropping point °C	170~190	170~190	200~250	150~180	150~180	70~90	250 or more	250 or more
Working temperature °C	-25~+120	-50~+120	-50~+160	-20~+120	-20~+120	-10~+80	-10~+130	-50~+200
Mechanical stability	Good	Fair	Fair	Good~Fair	Good~Fair	Fair~Poor	Fair	Fair
Pressure resistance	Fair	Fair	Poor	Fair	Good~Fair	Fair	Fair	Fair
Water resistance	Fair	Fair	Fair	Fair~Poor	Fair~Poor	Fair	Fair	Fair
Application	Most various Versatile rolling bearing grease	Superior in low temperature, friction properties	Suitable for high and low temperature Unsuitable for high load due to low oil film strength	Subject to emulsifying by mixing with water Relatively good properties to high temperature	Superior in water resistance and mechanical stability Suitable for bearing being subjected to vibration	Superior in viscosity Suitable for bearing being subjected to vibration	Vast application from low to high temperature It includes types showing superior properties in resistance to high and low temperature, and to chemical by combination with base oil and thickener Versatile rolling bearing grease	

Remark Working temperature range is for general properties only and NOT for guarantee purpose.

1) Base oil

Mineral oil and mixed oil are used for base oil of grease.

Diester oil and silicone oil are used as mixed oil.

Lubrication performance depends on viscosity of the base oil, and generally, low viscosity base oil is suitable for low temperature environment and high speed application, and high viscosity is for high temperature and high load application.

2) Thickener

Thickener is a material to keep grease in semi-solid state. Type of thickener has impact to maximum working temperature, water resistance and mechanical stability.

Metal-soap base is popular for material of thickener. In addition, there are thickeners such as urea base thickener with high heat resistance, and sodium soap-base thickener with poor water resistance due to easiness to emulsifying by mixing with water.

3) Consistency

Consistency refers to the “softness” of grease and it is used as a guideline for showing flow characteristics. The larger the ASTM penetration No. is, the softer the grease is. Table-33 shows typical relationship between consistency of grease and its operating conditions.

Table-33 Consistency of grease and its operating conditions

NLGI Grade No.	ASTM Penetration (1/10mm)	Operating conditions
0	355~385	Centralized lubrication Oscillating application
1	310~340	
2	265~295	General application
3	220~250	General, high temperature application
4	175~205	Grease with sealed application

4) Additives

Additives are material to improve performance of grease, which include antioxidants and extreme pressure additives added as necessary. Condition to use grease for long period without any replenishment requires added antioxidants to prevent oxidation.

Also, grease in operating conditions with heavy load or impact shock shall be selected from those with extreme pressure additives added.

5) Mixing different type greases

In principle, different brands of grease must not be mixed. Mixing different type grease is subject to negative impact each other due to change of consistency and difference of additives.

Table-34 Brand of lubricant grease (reference)

Category	Brand	Manufacturer	Thickener or soap-base	Consistency	Dropping point °C	Working temperature °C	Remark
General purpose	Alvania Grease S1	Showa Shell Sekiyu	Lithium soap	323	180	-35~120	General purpose
	Alvania Grease S2	Showa Shell Sekiyu	Lithium soap	283	181	-25~120	General purpose
	Alvania Grease S3	Showa Shell Sekiyu	Lithium soap	242	182	-20~135	General purpose
Wide working temperature	Fomblin RT-15	Solvay Solexis	PTFE	NO.2	300 or more	-20~250	High temperature
	Fomblin Y-VAC1	Solvay Solexis	PTFE	NO.1	300 or more	-20~250	High vacuum (soft)
	Fomblin Y-VAC2	Solvay Solexis	PTFE	NO.2	300 or more	-20~250	High vacuum (normal)
	Fomblin Y-VAC3	Solvay Solexis	PTFE	NO.3	300 or more	-20~250	High vacuum (rigid)
Low temperature	Multemp PS No.2	KYODO YUSHI	Lithium soap	NO.2	190	-50~130	Low temperature
Other	LOR#101	OIL CENTER RESEARCH	PTFE	295	198	-40~188	Superior in abrasion resistance, load resistance, water resistance and chemical resistance
	HP300	Dow Corning	PTFE	280	-	-65~250	Load resistance, oil resistance, solvent resistance, chemical resistance
	BARRIERTA SUPER IS/V	NOK KLUBER	PTFE	No.2	-	-35~260	High vacuum
	BARRIERTA IEL/V	NOK KLUBER	PTFE	No.2	-	-65~200	High vacuum
	ISO FLEX TOPAS NB 52	NOK KLUBER	Barium soap	No.2	240 or more	-50~150	Superior in heat resistance, load resistance, water resistance and high speed
	DEMNUM L-200	DAIKIN	PTFE	280	-	-60~300	High temperature stability
	DEMNUM L-65	DAIKIN	PTFE	280	-	-70~200	High temperature stability
	G1/3Grease	The Orelube Corporation	Non-soap grease	No.2	-	-23~180	High temperature, high load
	Shell Cassida Grease RLS2	Showa Shell Sekiyu	Aluminium complex	No.2	240 or more	-30~120	Superior in water resistance, oxidation stability and mechanical stability
	Super Lube item number 82329	Henkel	PTFE	No.2	-	-42~232	Extreme pressure, high temperature
Castrol Microcote 296	Castrol	PTFE	No.2	256	-50~204	Heat stability, low volatility, shear stability, high vacuum	

7-4 Oil lubrication

Oil lubrication is more suitable than grease for high speed rotation with superior cooling efficiency. It is suitable for application that requests emission of heat to outside that are generated in bearing or added to the bearing.

1) Oil bath lubrication

Oil bath lubrication is the most popular method used in medium to low speeds. Amount of oil needs to be properly controlled with oil gauge. Most proper oil amount may be with oil level at the center of the lowest needle roller of bearing. Housing design with less variation of oil level is preferable.

2) Oil drop lubrication

Oil drop lubrication is broadly used in application with high speed and medium load due to its better cooling efficiency than oil bath lubrication. Oil dripping through oiler in this method removes friction heat in a method to lubricate with oil fog filling inside of housing by hitting rotating objects such as shafts and nuts. While amount of oil varies depending on type of bearing and speed, general amount should be a couple of drops per minute.

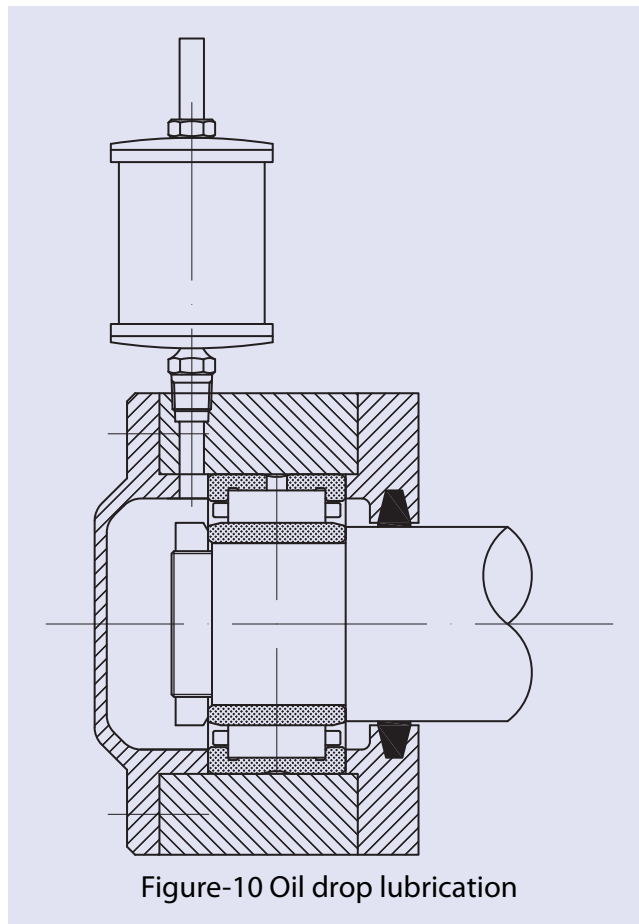

3) Oil splash lubrication

Oil splash lubrication is a method to splash oil with rotation of gear or disc. Unlike oil bath lubrication, it is applicable for relatively higher speed without having bearing in direct soak in oil.

4) Oil circulating lubrication

Oil circulating lubrication is widely used in application whose purpose is in cost efficiency for automatic lubrication with large number of lubrication spots, or is in cooling bearing. This lubrication method enables cooling or maintaining cleanness of lubricant with oil cooler and filters installed in oil circulation system. As shown in Figure-11, to make sure that lubrication oil is drained off certainly, it is important to have as much large outlet port as practical or forced outlet, setting inlet and outlet port of lubrication oil to opposite side each other to bearing.

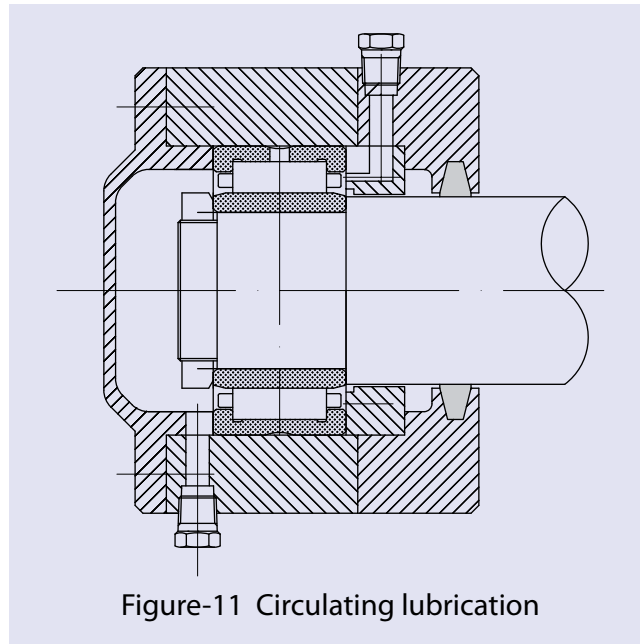

Lubrication oil

Highly refined mineral oil such as spindle oil, machine oil or turbine oil, or mixed oil are used as lubrication oil for bearing. Additives such as antioxidants, extreme pressure additives or deparant are selectively used as necessary in accordance with application.

It is important to select oil with proper viscosity for operation temperature. Too low viscosity causes insufficient formation of oil film which results in abrasion or heat-seizure. Too high viscosity causes heat generation or loss of power due to viscosity resistance. In general, oil with higher viscosity is used for higher load and lower viscosity for higher speeds.

8 Bearing handling

8-1 Precaution

Bearings are an extremely precision mechanical components. Exercise great care for its handling. Followings are precautions for the handling.

1) Keep bearings and surroundings clean

Foreign matters invaded inside of bearings such as dust and dirt have harmful effect in rotation or operation life on the bearings. Take extra precaution to maintain cleanness of bearing, surrounding components, work tools, lubricants, lubrications oil and working environment.

2) Handle bearings carefully

Shocks such as caused by falling bearing may result in damage or impressions on track or rolling elements. They can be a cause of failure so that handle bearings carefully.

3) Use proper tools

Make it sure to use work tools properly for bearing type for assembling and disassembling.

4) Pay attention to rust

Although bearings are applied with anti-rust oil, handling with bare hands may cause generation of rust with perspiration from hands. Exercise care and use rubber gloves or apply mineral oil to hands when handling with bare hands.

8-2 Mounting

Preparation

Bearings should be mounted in clean and dry circumstance. Dirt on mounting tools should be removed prior to mounting work, then verify that dimension accuracy, shaft and housing roughness and geometric accuracy are within designed tolerance.

Packing of bearings should be opened just before start mounting. Fill lubrication grease without washing bearing in the case of grease lubrication. Washing is generally not required for oil lubrication as well. Still it is recommended to thoroughly wash out oil and grease when application demands high accuracy or lubricating performance is degraded by mixing lubricant and anti-rust agents.

Mounting method

1) Press fitting

In mounting bearings from small to medium sizes which don't need large forces, press fittings in room temperature are conducted widely. In this case, use pressing fixture as shown in Figure-12 to apply force evenly at side of bearing and press it in carefully. Applying high viscosity oil on fitting surface during work may reduce friction on the surface.

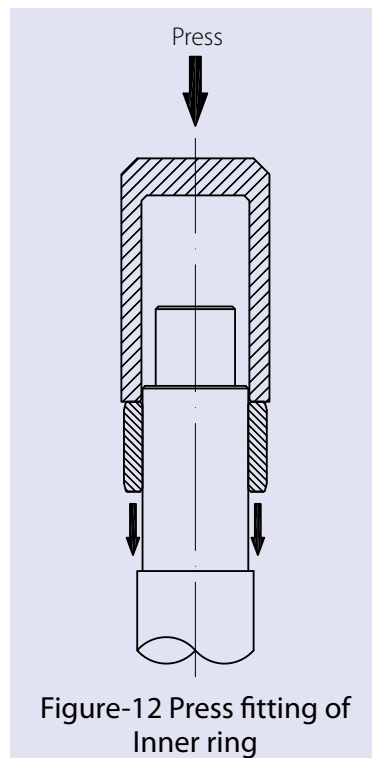

2) Shrink fitting

Shrink fitting is broadly used for tighter interference or mounting large size bearing. How to fit is heating housing for outer ring and inner ring for shaft respectively with pure mineral oil with less corrosivity in order to expand their inner diameter for mounting onto the shaft. Heating temperature must not exceed 120° C. During mounting, inner ring could expand toward shaft direction so that it needs to be pressed against shoulder until completion of cool down to avoid gap between the inner ring and the shoulder.

8-3 Operation inspection

Operation inspection needs to be performed in order to confirm that bearings is properly mounted. Power operation at given speed without operation inspection may result in damage of bearings or heat-seizure due to lubrication failure in the case that mounting is insufficient. Shaft or housing should be rotated by hand after bearing mounting to confirm if there is no abnormality followed by check (or inspection) in stepping increase of speed from no load, low speed operation with power up to loaded operation.

Followings are typical abnormal items and major causes that can be checked in the operation inspection.

1) Check item in operation by hand

- Fluctuation in rotation torque, Insufficient mounting
- Sticks and abnormal noise, Impression, damage, invasion of dirt or foreign matters in track surface
- Excessive torque, Insufficiently small clearance

2) Check item in operation by power

- Abnormal noise, vibration ····· Impression, invasion of dirt or foreign matters in track surface, excessive clearance
- Abnormal temperature ······· Insufficient lubrication, insufficient mounting, insufficiently small clearance

8-4 Removing

Bearing may be removed for periodical machine maintenance or repair for trouble. Bearing and other components should be carefully disassembled in the same manner as the mounting in the case of re-using disassembled bearing or researching trouble condition.

Bearings should be carried out in an appropriate manner in accordance with type of bearing and condition of fits. Structure design should take disassembling work into consideration at planning stage of construction around the bearing since it would be difficult to disassemble especially the tight fit bearing.

Removing outer ring

Installing bolts for disassembling outer ring at several locations in circumference of housing will allow removing outer ring assembled with tight fits easily by tightening-up the screws evenly as shown in Figure-13.

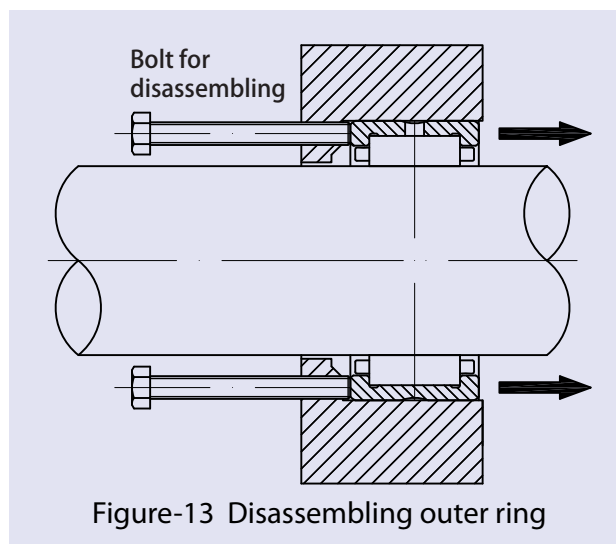
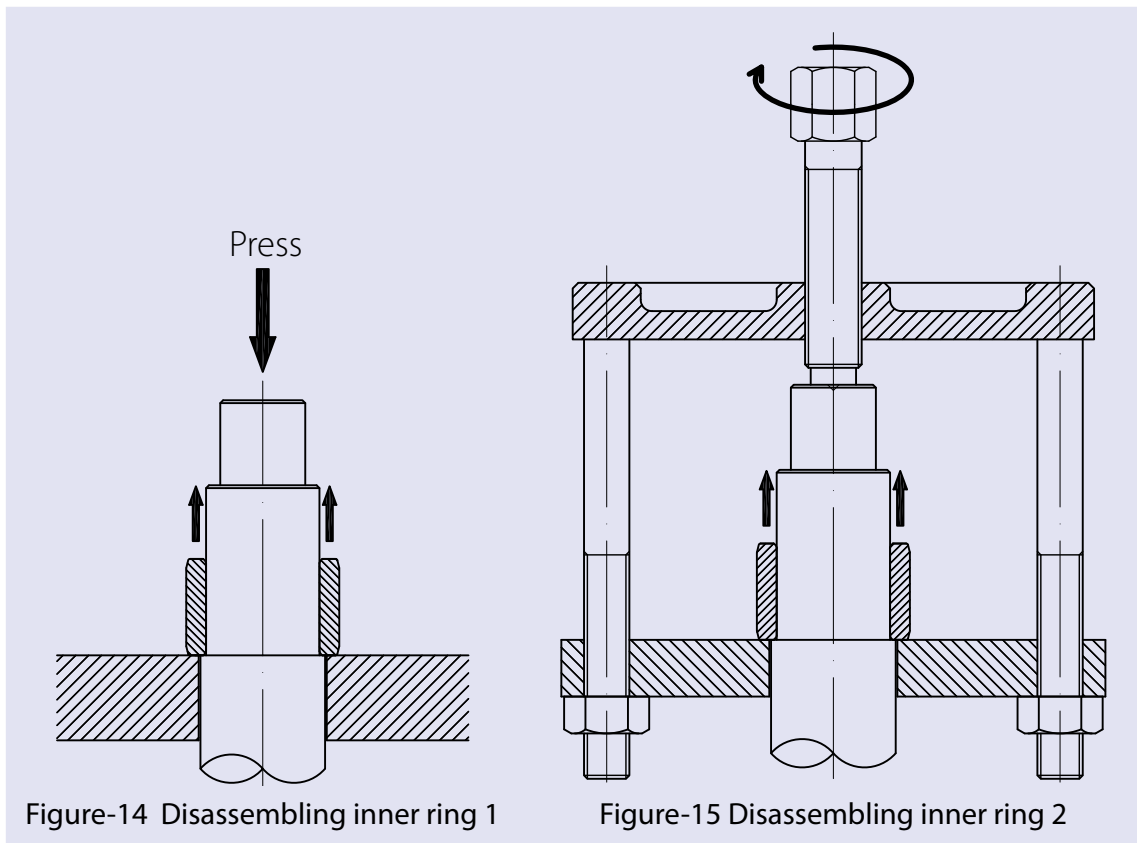

Figure-13 Disassembling outer ring

Disassembling inner ring

Inner rings can be carried out most easily by pulling out by press (Figure-14). Dedicated removal tool (Figure-15) designed in accordance with dimension of the bearing is in use as well.



8-5 Maintenance and inspection

Periodical maintenance and inspection are essential for maximizing performance and prolonged usage of bearing as well as early discovery of abnormality of the bearings. Inspection items of bearings under operation include temperature, operation sound, vibration of bearings and condition of lubricant, whose observation enables judging timing of lubricant replenishment and replacement of components.

MACHINED RING NEEDLE ROLLER BEARINGS

WITHOUT INNER RING

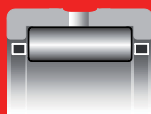

RNA, NK

RNA49, RNA59, RNA69, RNA48, NK TYPE

Shaft Diameter (mm)	Designation					Dimensions (mm)				
	RNA 49	RNA 59	RNA 69	RNA 48	NK	Fw	D	C	r/s min	
5	—	—	—	—	NK5/10 NK5/12	5 +0.018 5 +0.010	10 10	10 12	0.15 0.15	
6	—	—	—	—	NK6/10 NK6/12	6 +0.018 6 +0.010	12 12	10 12	0.015 0.15	
7	RNA 495 — —	— — —	— — —	— — —	— NK7/10 NK7/12	7 7 +0.022 7 +0.013	13 14 14	10 10 12	0.15 0.3 0.3	
8	RNA 496 — —	— — —	— — —	— — —	— NK8/12 NK8/16	8 8 +0.022 8 +0.013	15 15 15	10 12 16	0.15 0.3 0.3	
9	— — RNA 497	— — —	— — —	— — —	NK9/12 NK9/16 —	9 9 +0.022 9 +0.013	16 16 17	12 16 10	0.3 0.3 0.15	
10	— — RNA 498	— — —	— — —	— — —	NK10/12 NK10/16 —	10 10 +0.022 10 +0.013	17 17 19	12 16 11	0.3 0.3 0.2	
12	— — RNA 499	— — —	— — —	— — —	NK12/12 NK12/16 —	12 12 +0.027 12 +0.016	19 19 20	12 16 11	0.3 0.3 0.3	

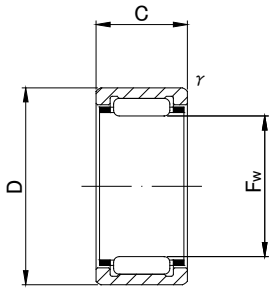

NK($F_w \leq 10$)

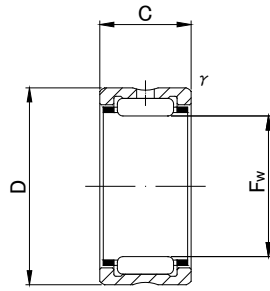

RNA49, RNA59, RNA69($F_w \leq 35$), NK

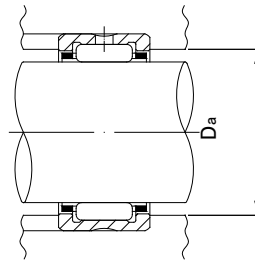

Standard mounting dimensions (mm)	Basic dynamic load rating	Basic static load rating	Limiting speed *	Mass	Usable bearing designation	
Da MAX	Cr N	Cor N	rpm	g (approx)	INNER RING	WITH INNER RING
6.5	2 420	1 950	40 000	3.4	—	—
6.5	3 080	2 660	40 000	4.2	—	—
7.5	2 700	2 320	37 000	5.3	—	—
7.5	3 440	3 170	37 000	6.4	—	—
8.5	2 960	2 690	34 000	5.9	IR5710	NA495
8.5	3 600	2 960	34 000	6.9	—	—
8.5	4 610	4 050	34 000	8.3	—	—
13.8	3 900	3 400	32 000	7.3	IR6810	NA496
13	5 100	4 700	32 000	9	IR5812	NKI 5/12
13	7 100	7 300	32 000	13	IR5816	NKI 5/16
14	5 500	5 300	30 000	10	IR6912	NKI 6/12
14	7 600	8 200	30 000	13.2	IR6916	NKI 6/16
15.8	4 500	3 600	30 000	9.3	IR7910	NA497
15	5 900	6 000	28 000	10.7	IR71012	NKI 7/12
15	8 200	9 200	28 000	14.3	IR71016	NKI 7/16
17.4	6 200	5 000	28 000	12.6	IR81011	NA498
17	6 600	7 300	26 000	12.2	IR91212	NKI 9/12
17	9 200	11 200	26 000	16.3	IR91216	NKI 9/16
18	6 600	6 300	26 000	13.6	IR91211	NA499

* Suitable for oil lubrication. In case of grease lubrication, down to 60% of this value.

MACHINED RING NEEDLE ROLLER BEARINGS

WITHOUT INNER RING

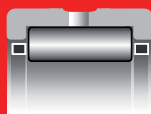

RNA, NK

RNA49, RNA59, RNA69, RNA48, NK TYPE

Shaft Diameter (mm)	Designation					Dimensions (mm)			
	RNA 49	RNA 59	RNA 69	RNA 48	NK	Fw	D	C	r/s min
14	RNA 4900 — —	— — —	— — —	— — —	— NK14/16 NK14/20	14 14 +0.027 14 +0.016	22 22 22	13 16 20	0.3 0.3 0.3
15	— —	— —	— —	— —	NK15/16 NK15/20	15 +0.027 15 +0.016	23 23	16 20	0.3 0.3
16	RNA 4901 — — —	— — — —	— — — RNA 6901	— — — —	— NK16/16 NK16/20 —	16 16 +0.027 16 +0.016 16	24 24 24 24	13 16 20 22	0.3 0.3 0.3 0.3
17	— —	— —	— —	— —	NK17/16 NK17/20	17 +0.027 17 +0.016	25 25	16 20	0.3 0.3
18	— —	— —	— —	— —	NK18/16 NK18/20	18 +0.027 18 +0.016	26 26	16 20	0.3 0.3
19	— —	— —	— —	— —	NK19/16 NK19/20	19 +0.033 19 +0.020	27 27	16 20	0.3 0.3
20	RNA 4902 — — — —	— — RNA 5902 — —	— — — RNA 6902	— — — —	— NK20/16 — NK20/20 —	20 20 20 +0.033 20 +0.020 20	28 28 28 28 28	13 16 18 20 23	0.3 0.3 0.3 0.3 0.3

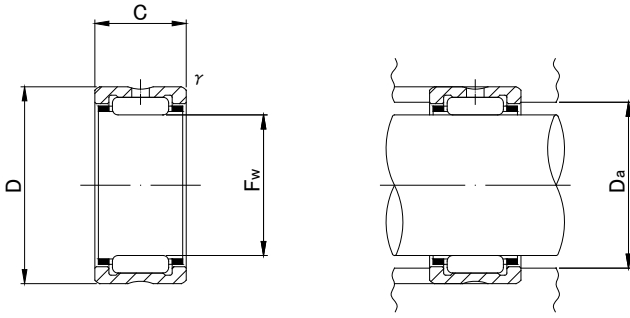

RNA49, RNA59, RNA69 ($F_w \leq 35$), NK



Standard mounting dimensions (mm)	Basic dynamic load rating	Basic static load rating	Limiting speed *	Mass	Usable bearing designation	
Da MAX	Cr N	Cor N	rpm	g (approx)	INNER RING	WITH INNER RING
20	9 200	10 100	24 000	16.5	IR101413	NA4900
20	11 800	13 700	24 000	21	IR101416	NKI 10/16
20	14 800	18 500	24 000	26.5	IR101420	NKI 10/20
21	12 400	14 900	23 000	22.5	—	—
21	15 600	20 200	23 000	28	—	—
22	9 700	11 100	23 000	18.1	IR121613	NA4901
22	12 300	15 100	23 000	23	IR121616	NKI 12/16
22	15 600	20 400	23 000	29	IR121620	NKI 12/20
22	17 100	23 000	23 000	30	IR121622	NA6901
23	12 800	16 300	22 000	24.5	—	—
23	16 300	22 100	22 000	30.5	—	—
24	13 400	17 500	21 000	25.5	—	—
24	17 000	23 600	21 000	32	—	—
25	14 000	18 700	21 000	27	IR151916	NKI 15/16
25	17 700	25 300	21 000	34	IR151920	NKI 15/20
26	10 900	13 800	20 000	21.5	IR152013	NA4902
26	13 900	18 700	20 000	27.5	—	—
26	15 700	22 100	20 000	33	IR152018	NA5902
26	17 600	25 400	20 000	35.5	—	—
26	19 300	28 700	20 000	37	IR152023	NA6902

* Suitable for oil lubrication. In case of grease lubrication, down to 60% of this value.

MACHINED RING NEEDLE ROLLER BEARINGS

WITHOUT INNER RING

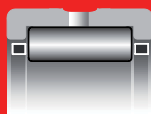

RNA, NK

RNA49, RNA59, RNA69, RNA48, NK TYPE

Shaft Diameter (mm)	Designation					Dimensions (mm)				
	RNA 49	RNA 59	RNA 69	RNA 48	NK	Fw	D	C	r/s min	
21	—	—	—	—	NK21/16 NK21/20	21 +0.033 21 +0.020	29 29	16 20	0.3 0.3	
22	RNA 4903 — — — —	— — RNA 5903 — —	— — — — RNA 6903	— — — —	— NK22/16 — NK22/20 —	22 22 22 +0.033 22 +0.020 22	30 30 30 30 30	13 16 18 20 23	0.3 0.3 0.3 0.3 0.3	
24	—	—	—	—	NK24/16 NK24/20	24 +0.033 24 +0.020	32 32	16 20	0.3 0.3	
25	— — RNA 4904 — —	— — — RNA 5904 —	— — — — RNA 6904	— — — —	NK25/16 NK25/20 — — —	25 25 25 +0.033 25 +0.020 25	33 33 37 37 37	16 20 17 23 30	0.3 0.3 0.3 0.3 0.3	
26	—	—	—	—	NK26/16 NK26/20	26 +0.033 26 +0.020	34 34	16 20	0.3 0.3	
28	— — RNA 49/22 — —	— — — RNA 59/22 —	— — — — RNA 69/22	— — — —	NK28/20 NK28/30 — — —	28 28 28 +0.033 28 +0.020 28	37 37 39 39 39	20 30 17 23 30	0.3 0.3 0.3 0.3 0.3	
29	—	—	—	—	NK29/20 NK29/30	29 +0.033 29 +0.020	38 38	20 30	0.3 0.3	

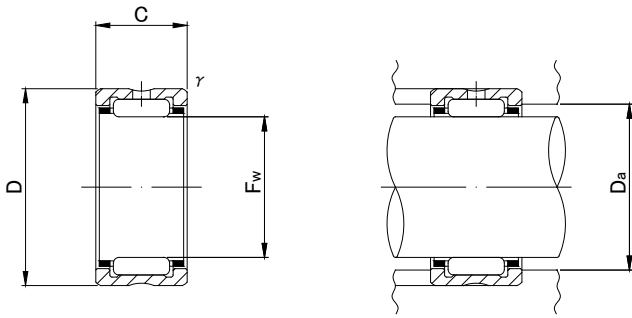

RNA49, RNA59, RNA69 ($F_w \leq 35$), NK



Standard mounting dimensions (mm)	Basic dynamic load rating	Basic static load rating	Limiting speed *	Mass	Usable bearing designation	
Da MAX	Cr N	Cor N	rpm	g (approx)	INNER RING	WITH INNER RING
27	14 400	20 000	19 000	29	IR172116	NKI 17/16
27	18 200	27 100	19 000	36	IR172120	NKI 17/20
28	11 800	15 600	18 000	23.5	IR172213	NA4903
28	14 900	21 200	18 000	30	—	—
28	16 900	24 900	18 000	35	IR172218	NA5903
28	18 900	28 700	18 000	37.5	—	—
28	20 800	32 500	18 000	40.5	IR172223	NA6903
30	15 300	22 600	17 000	32	IR202416	NKI 20/16
30	19 400	30 500	17 000	40.5	IR202420	NKI 20/20
31	15 800	23 700	16 000	33.5	—	—
31	20 000	32 200	16 000	42	—	—
35	21 000	25 000	16 000	55.5	IR202517	NA4904
35	29 400	38 600	16 000	84	IR202523	NA5904
35	35 400	48 800	16 000	95.5	IR202530	NA6904
32	16 300	24 900	15 000	34.5	IR222616	NKI 22/16
32	20 600	33 700	15 000	43.5	IR222620	NKI 22/20
35	21 700	37 100	14 000	51.5	—	—
35	31 100	58 900	14 000	83.5	—	—
37	21 400	28 800	14 000	56.5	IR222817	NA49/22
37	29 800	44 400	14 000	92	IR222823	NA59/22
37	36 300	56 900	14 000	97.5	IR222830	NA69/22
36	21 600	37 200	14 000	57	IR252920	NKI 25/20
36	30 900	59 000	14 000	85	IR252930	NKI 25/30

* Suitable for oil lubrication. In case of grease lubrication, down to 60% of this value.

MACHINED RING NEEDLE ROLLER BEARINGS WITHOUT INNER RING

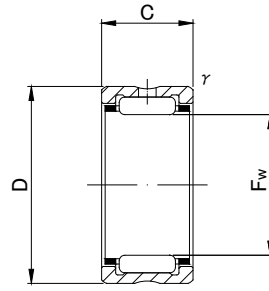
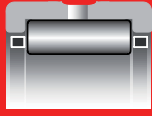

RNA49, RNA59, RNA69 ($F_w \leq 35$), NK

RNA49, RNA59, RNA69, RNA48, NK TYPE

Shaft Diameter (mm)	Designation					Dimensions (mm)				
	RNA 49	RNA 59	RNA 69	RNA 48	NK	F _w	D	C	r _s min	
30	—	—	—	—	NK30/20	30	+0.033 +0.020	40	20	0.3
	—	—	—	—	NK30/30	30		40	30	0.3
	RNA 4905	—	—	—	—	30		42	17	0.3
	—	RNA 5905	—	—	—	30		42	23	0.3
	—	—	RNA 6905	—	—	30		42	30	0.3
32	—	—	—	—	NK32/20	32	+0.041 +0.025	42	20	0.3
	—	—	—	—	NK32/30	32		42	30	0.3
	RNA 49/28	—	—	—	—	32		45	17	0.3
	—	RNA 59/28	—	—	—	32		45	23	0.3
35	—	—	—	—	NK35/20	35	+0.041 +0.025	45	20	0.3
	—	—	—	—	NK35/30	35		45	30	0.3
	RNA 4906	—	—	—	—	35		47	17	0.3
	—	RNA 5906	—	—	—	35		47	23	0.3
37	—	—	—	—	NK37/20	37	+0.041 +0.025	47	20	0.3
	—	—	—	—	NK37/30	37		47	30	0.3
	—	—	—	—	—	—		—	—	—
38	—	—	—	—	NK38/20	38	+0.041 +0.025	48	20	0.3
	—	—	—	—	NK38/30	38		48	30	0.3
40	—	—	—	—	NK40/20	40	+0.041 +0.025	50	20	0.3
	—	—	—	—	NK40/30	40		50	30	0.3
	RNA 49/32	—	—	—	—	40		52	20	0.6
	—	RNA 59/32	—	—	—	40		52	27	0.6
42	—	—	—	—	NK42/20	42	+0.041 +0.025	52	20	0.3
	—	—	—	—	NK42/30	42		52	30	0.3
	RNA 4907	—	—	—	—	42		55	20	0.6
	—	RNA 5907	—	—	—	42		55	27	0.6
	—	—	RNA 6907	—	—	42		55	36	0.6

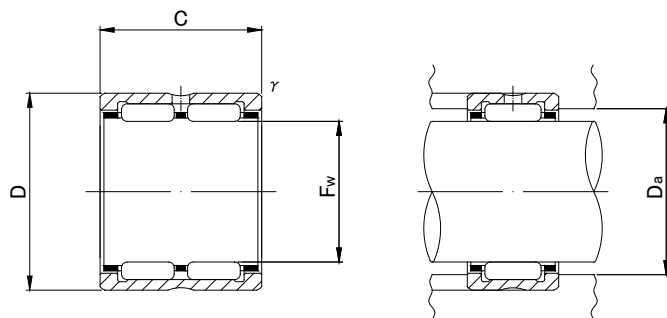

RNA69



Standard mounting dimensions (mm)	Basic dynamic load rating	Basic static load rating	Limiting speed *	Mass	Usable bearing designation	
Da MAX	Cr N	Cor N	rpm	g (approx)	INNER RING	WITH INNER RING
38	25 100	40 100	13 000	64.5	—	—
38	36 000	63 800	13 000	97.5	—	—
40	23 700	30 700	13 000	64	IR253017	NA4905
40	33 200	47 500	13 000	101	IR253023	NA5905
40	42 100	64 200	13 000	111	IR253030	NA6905
40	25 700	42 200	13 000	68	IR283220	NKI 28/20
40	36 900	67 100	13 000	102	IR283230	NKI 28/30
43	24 500	32 700	13 000	76.5	IR283217	NA49/28
43	34 300	50 500	13 000	108	IR283223	NA59/28
43	41 800	64 700	13 000	133	IR283230	NA69/28
43	27 000	46 200	11 000	73.5	IR303520	NKI 30/20
43	38 600	73 500	11 000	112	IR303530	NKI 30/30
45	25 200	34 700	11 000	72.5	IR303517	NA4906
45	35 200	53 700	11 000	108	IR303523	NA5906
45	43 100	69 000	11 000	125	IR303530	NA6906
45	28 200	50 100	11 000	77.5	IR323720	NKI 32/20
45	40 500	79 800	11 000	117	IR323730	NKI 32/30
46	28 100	50 200	11 000	79	—	—
46	40 300	80 000	11 000	119	—	—
48	29 400	54 100	10 000	83	IR354020	NKI 35/20
48	42 300	86 100	10 000	125	IR354030	NKI 35/30
48	31 300	47 900	10 000	96	IR324020	NA49/32
48	41 900	69 900	10 000	149	IR324027	NA59/32
48	53 500	95 700	10 000	172	IR324036	NA69/32
50	29 900	56 200	9 500	86.5	—	—
50	43 000	89 500	9 500	130	—	—
51	32 000	50 200	9 500	113	IR354220	NA4907
51	42 900	73 200	9 500	176	IR354227	NA5907
51	54 800	100 000	9 500	200	IR354236	NA6907

* Suitable for oil lubrication. In case of grease lubrication, down to 60% of this value.

MACHINED RING NEEDLE ROLLER BEARINGS WITHOUT INNER RING

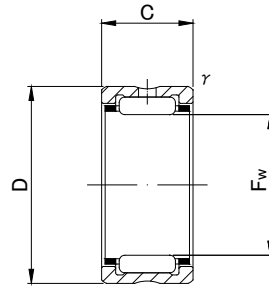
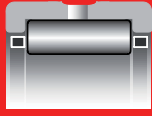

RNA49, RNA59, RNA48, NK

RNA49, RNA59, RNA69, RNA48, NK TYPE

Shaft Diameter (mm)	Designation					Dimensions (mm)					
	RNA 49	RNA 59	RNA 69	RNA 48	NK	F _w	D	C	r's min		
43	—	—	—	—	NK43/20	43 +0.041	53	20	0.3		
	—	—	—	—		43 +0.025				30	0.3
45	—	—	—	—	NK45/20	45 +0.041	55	20	0.3		
	—	—	—	—		45 +0.025				30	0.3
47	—	—	—	—	NK47/20	47 +0.041	57	20	0.3		
	—	—	—	—		47 +0.025				30	0.3
48	RNA 4908	—	—	—	—	48 +0.041	62	22	0.6		
	—	RNA 5908	—	—		48 +0.025				30	0.6
	—	—	RNA 6908	—		48				40	0.6
50	—	—	—	—	NK50/25	50 +0.041	62	25	0.6		
	—	—	—	—		50 +0.025				35	0.6
52	RNA 4909	—	—	—	—	52 +0.049	68	22	0.6		
	—	RNA 5909	—	—		52 +0.030				30	0.6
	—	—	RNA 6909	—		52				40	0.6
55	—	—	—	—	NK55/25	55 +0.049	68	25	0.6		
	—	—	—	—		55 +0.030				35	0.6

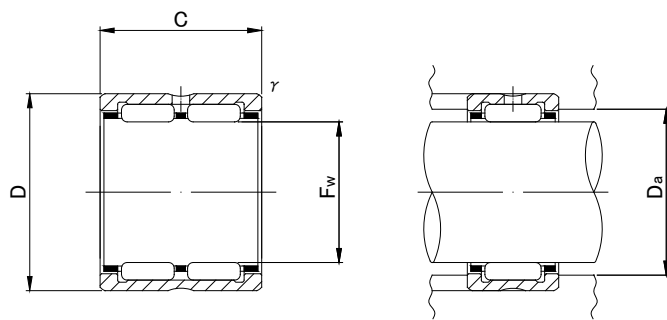

RNA69



Standard mounting dimensions (mm)	Basic dynamic load rating	Basic static load rating	Limiting speed *	Mass	Usable bearing designation	
Da MAX	Cr N	Cor N	rpm	g (approx)	INNER RING	WITH INNER RING
51 51	30 500 43 700	58 100 92 500	9 500 9 500	88.5 133	IR384320 IR384330	NKI 38/20 NKI 38/30
53 53	31 100 44 500	60 100 95 700	9 000 9 000	92 138	IR404520 IR404530	NKI 40/20 NKI 40/30
55 55	31 500 45 200	62 300 99 000	8 500 8 500	95 144	IR424720 IR424730	NKI 42/20 NKI 42/30
58 58 58	41 600 58 000 71 300	67 400 103 000 134 400	8 500 8 500 8 500	152 225 275	IR404822 IR404830 IR404840	NA4908 NA5908 NA6908
58 58	43 000 58 100	85 200 125 500	8 000 8 000	159 225	IR455025 IR455035	NKI 45/25 NKI 45/35
64 64 64	43 500 60 700 74 600	73 400 112 000 147 100	7 500 7 500 7 500	197 232 355	IR455222 IR455230 IR455240	NA4909 NA5909 NA6909
64 64	45 400 61 300	94 100 138 300	7 500 7 500	193 255	IR505525 IR505535	NKI 50/25 NKI 50/35

* Suitable for oil lubrication. In case of grease lubrication, down to 60% of this value.

MACHINED RING NEEDLE ROLLER BEARINGS WITHOUT INNER RING

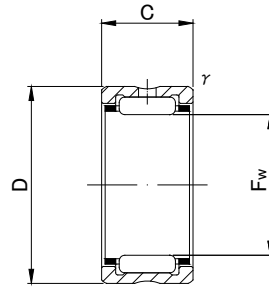
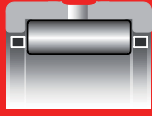

RNA49, RNA59, RNA48, NK

RNA49, RNA59, RNA69, RNA48, NK TYPE

Shaft Diameter (mm)	Designation					Dimensions (mm)			
	RNA 49	RNA 59	RNA 69	RNA 48	NK	F _w	D	C	r/s min
58	RNA 4910 — —	— RNA 5910 —	— — RNA 6910	— — —	— — —	58 58 +0.049 58 +0.030	72 72 72	22 30 40	0.6 0.6 0.6
60	— —	— —	— —	— —	NK60/25 NK60/35	60 +0.049 60 +0.030	72 72	25 35	0.6 0.6
63	RNA 4911 — —	— RNA 5911 —	— — RNA 6911	— — —	— — —	63 63 +0.049 63 +0.030	80 80 80	25 34 45	1 1 1
65	— —	— —	— —	— —	NK65/25 NK65/35	65 +0.049 65 +0.030	78 78	25 35	0.6 0.6
68	— — RNA 4912 — —	— — — RNA 5912 —	— — — — RNA 6912	— — — — —	NK68/25 NK68/35 — — —	68 68 68 +0.049 68 +0.030 68	82 82 85 85 85	25 35 25 34 45	0.6 0.6 1 1 1
70	— —	— —	— —	— —	NK70/25 NK70/35	70 +0.049 70 +0.030	85 85	25 35	0.6 0.6
72	RNA 4913 — —	— RNA 5913 —	— — RNA 6913	— — —	— — —	72 72 +0.049 72 +0.030	90 90 90	25 34 45	1 1 1

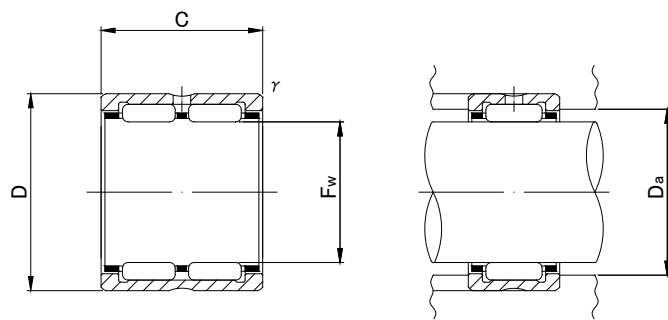

RNA69



Standard mounting dimensions (mm)	Basic dynamic load rating	Basic static load rating	Limiting speed *	Mass	Usable bearing designation	
Da MAX	Cr N	Cor N	rpm	g (approx)	INNER RING	WITH INNER RING
68	46 200	82 100	7 000	179	IR505822	NA4910
68	64 400	126 000	7 000	289	IR505830	NA5910
68	79 100	163 800	7 000	320	IR505840	NA6910
68	47 500	103 000	6 500	187	IR556025	NKI 55/25
68	64 100	151 000	6 500	260	IR556035	NKI 55/35
75	57 600	97 300	6 500	265	IR556325	NA4911
75	82 600	154 000	6 500	367	IR556334	NA5911
75	99 000	194 200	6 500	475	IR556345	NA6911
74	49 600	111 800	6 000	225	—	—
74	67 000	164 800	6 000	315	—	—
78	54 800	116 700	6 000	250	IR606825	NKI 60/25
78	72 100	165 700	6 000	350	IR606835	NKI 60/35
80	60 100	104 900	6 000	285	IR606825	NA4912
80	86 100	167 000	6 000	408	IR606834	NA5912
80	103 000	210 800	6 000	510	IR606845	NA6912
81	55 500	120 600	5 500	280	—	—
81	73 000	170 600	5 500	395	—	—
85	62 800	113 800	5 500	325	IR657225	NA4913
85	89 900	180 000	5 500	462	IR657234	NA5913
85	107 900	226 500	5 500	585	IR657245	NA6913

* Suitable for oil lubrication. In case of grease lubrication, down to 60% of this value.

MACHINED RING NEEDLE ROLLER BEARINGS WITHOUT INNER RING

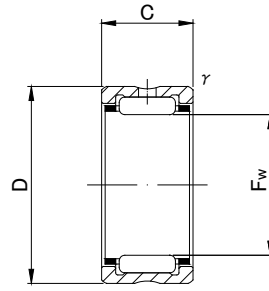
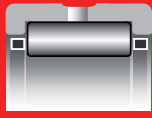

RNA49, RNA59, RNA48, NK

RNA49, RNA59, RNA69, RNA48, NK TYPE

Shaft Diameter (mm)	Designation					Dimensions (mm)				
	RNA 49	RNA 59	RNA 69	RNA 48	NK	F _w	D	C	r _s min	
73	—	—	—	—	NK73/25	73 +0.049	90	25	0.6	
	—	—	—	—	NK73/35	73 +0.030	90	35	0.6	
75	—	—	—	—	NK75/25	75 +0.049	92	25	0.6	
	—	—	—	—	NK75/35	75 +0.030	92	35	0.6	
80	—	—	—	—	NK80/25	80 +0.049 +0.030	95	25	1	
	—	—	—	—	NK80/35		95	35	1	
	RNA 4914	—	—	—	—		100	30	1	
	—	RNA 5914	—	—	—		100	40	1	
	—	—	RNA 6914	—	—		100	54	1	
85	—	—	—	—	NK85/25	85 +0.058 +0.036	105	25	1	
	RNA 4915	—	—	—	—		105	30	1	
	—	—	—	—	NK85/35		105	35	1	
	—	RNA 5915	—	—	—		105	40	1	
	—	—	RNA 6915	—	—		105	54	1	
90	—	—	—	—	NK90/25	90 +0.058 +0.036	110	25	1	
	RNA 4916	—	—	—	—		110	30	1	
	—	—	—	—	NK90/35		110	35	1	
	—	RNA 5916	—	—	—		110	40	1	
	—	—	RNA 6916	—	—		110	54	1	
95	—	—	—	—	NK95/26	95 +0.058	115	26	1	
	—	—	—	—	NK95/36	95 +0.036	115	36	1	
100	—	—	—	—	NK100/26	100 +0.058 +0.036	120	26	1	
	RNA 4917	—	—	—	—		120	35	1.1	
	—	—	—	—	NK100/36		120	36	1	
	—	RNA 5917	—	—	—		120	46	1.1	
	—	—	RNA 6917	—	—		120	63	1.1	

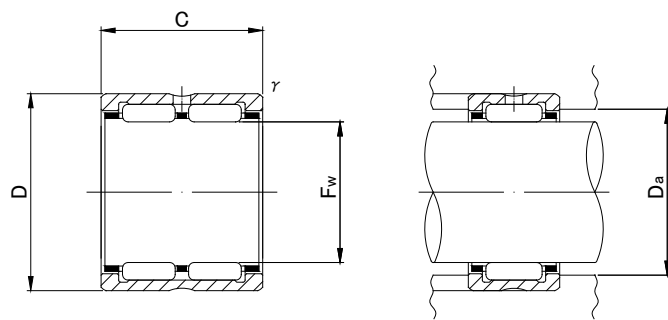

RNA69



Standard mounting dimensions (mm)	Basic dynamic load rating	Basic static load rating	Limiting speed *	Mass	Usable bearing designation	
Da MAX	Cr N	Cor N	rpm	g (approx)	INNER RING	WITH INNER RING
86 86	61 100 80 400	126 500 180 400	5 500 5 500	335 475	— IR657335	— NKI 65/35
88 88	62 200 82 700	130 400 186 300	5 500 5 500	345 485	— —	— —
90 90 95 95 95	59 400 78 100 83 200 112 000 133 400	137 300 194 200 157 900 232 000 310 900	5 000 5 000 5 000 5 000 5 000	315 445 495 706 910	IR708025 IR708035 IR708030 IR708040 IR708054	NKI 70/25 NKI 70/35 NA4914 NA5914 NA6914
100 100 100 100 100	76 400 86 200 102 000 116 000 138 300	145 100 169 700 209 900 249 000 330 500	4 500 4 500 4 500 4 500 4 500	435 525 610 745 960	IR758525 IR758530 IR758535 IR758540 IR758554	NKI 75/25 NA4915 NKI 75/35 NA5915 NA6915
105 105 105 105 105	77 400 87 400 103 000 117 000 143 200	150 000 174 600 216 700 257 000 350 100	4 500 4 500 4 500 4 500 4 500	456 550 640 787 1 010	IR809025 IR809030 IR809035 IR809040 IR809054	NKI 80/25 NA4916 NKI 80/35 NA5916 NA6916
110 110	79 700 106 900	158 900 230 500	4 200 4 200	495 690	IR859526 IR859536	NKI 85/26 NKI 85/36
115 113.5 115 113.5 113.5	82 500 109 800 109 800 144 000 172 600	168 700 244 200 244 200 346 000 466 800	4 000 4 000 4 000 4 000 4 000	525 705 725 1 000 1 300	IR9010026 IR8510035 IR9010036 IR8510046 IR8510063	NKI 90/26 NA4917 NKI 90/36 NA5917 NA6917

* Suitable for oil lubrication. In case of grease lubrication, down to 60% of this value.

MACHINED RING NEEDLE ROLLER BEARINGS WITHOUT INNER RING

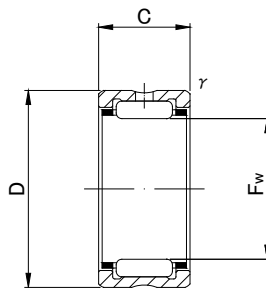
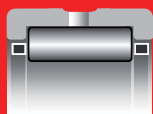

RNA49, RNA59, RNA48, NK

RNA49, RNA59, RNA69, RNA48, NK TYPE

Shaft Diameter (mm)	Designation					Dimensions (mm)			
	RNA 49	RNA 59	RNA 69	RNA 48	NK	F _w	D	C	r/s min
105	—	—	—	—	NK105/26	105	125	26	1
	RNA 4918	—	—	—	—	105	125	35	1.1
	—	—	—	—	NK105/36	105 ^{+0.058}	125	36	1
	—	RNA 5918	—	—	—	105 ^{+0.036}	125	46	1.1
	—	—	RNA 6918	—	—	105	125	63	1.1
110	—	—	—	—	NK110/30	110	130	30	1.1
	RNA 4919	—	—	—	—	110	130	35	1.1
	—	—	—	—	NK110/40	110 ^{+0.058}	130	40	1.1
	—	RNA 5919	—	—	—	110 ^{+0.036}	130	46	1.1
	—	—	RNA 6919	—	—	110	130	63	1.1
115	RNA 4920	—	—	—	—	115 ^{+0.058}	140	40	1.1
120	—	—	—	RNA 4822	—	120 ^{+0.058}	140	30	1
125	RNA 4922	—	—	—	—	125 ^{+0.068}	150	40	1.1
130	—	—	—	RNA 4824	—	130 ^{+0.068}	150	30	1
135	RNA 4924	—	—	—	—	135 ^{+0.068}	165	45	1.1

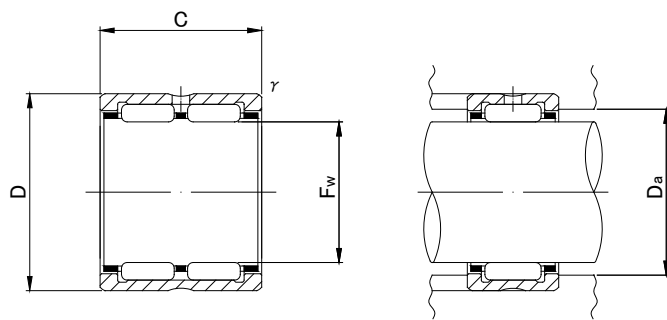

RNA69



Standard mounting dimensions (mm)	Basic dynamic load rating	Basic static load rating	Limiting speed *	Mass	Usable bearing designation	
Da MAX	Cr N	Cor N	rpm	g (approx)	INNER RING	WITH INNER RING
120	84 700	177 500	3 800	545	IR9510526	NKI 95/26
118.5	112 800	257 900	3 800	740	IR9010535	NA4918
120	112 800	257 900	3 800	760	IR9510536	NKI 95/36
118.5	148 000	365 000	3 800	1 040	IR9010546	NA5918
118.5	177 500	490 300	3 800	1 360	IR9010563	NA6918
123.5	105 900	239 300	3 600	660	IR10011030	NKI 100/30
123.5	116 700	270 700	3 600	770	IR9511035	NA4919
123.5	133 400	323 600	3 600	880	IR10011040	NKI 100/40
123.5	152 000	384 000	3 600	1 130	IR9511046	NA5919
1 123.5	182 400	514 800	3 600	1 420	IR9511063	NA6919
133.5	145 000	329 000	3 500	1 190	IR10011540	NA4920
135	93 000	239 000	3 500	790	IR11012030	NA4822
143.5	152 000	357 000	3 000	1 280	IR11012540	NA4922
145	97 000	259 000	3 000	850	IR12013030	NA4824
158.5	187 000	435 000	3 000	1 930	IR12013545	NA4924

* Suitable for oil lubrication. In case of grease lubrication, down to 60% of this value.

MACHINED RING NEEDLE ROLLER BEARINGS WITHOUT INNER RING

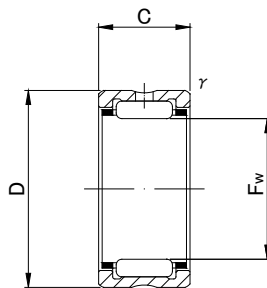
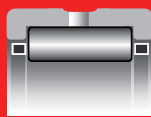

RNA49, RNA59, RNA48, NK

RNA49, RNA59, RNA69, RNA48, NK TYPE

Shaft Diameter (mm)	Designation					Dimensions (mm)			
	RNA 49	RNA 59	RNA 69	RNA 48	NK	F _w	D	C	r's min
145	—	—	—	RNA 4826	—	145 ^{+0.068} / _{+0.043}	165	35	1.1
150	RNA 4926	—	—	—	—	150 ^{+0.068} / _{+0.043}	180	50	1.5
155	—	—	—	RNA 4828	—	155 ^{+0.068} / _{+0.043}	175	35	1.1
160	RNA 4928	—	—	—	—	160 ^{+0.068} / _{+0.043}	190	50	1.5
165	—	—	—	RNA 4830	—	165 ^{+0.068} / _{+0.043}	190	40	1.1
175	—	—	—	RNA 4832	—	175 ^{+0.068} / _{+0.043}	200	40	1.1

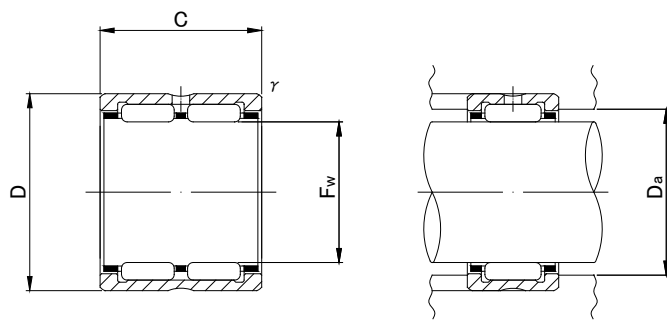

RNA69



Standard mounting dimensions (mm)	Basic dynamic load rating	Basic static load rating	Limiting speed *	Mass	Usable bearing designation	
Da MAX	Cr N	Cor N	rpm	g (approx)	INNER RING	WITH INNER RING
158.5	117 000	340 000	3 000	1 100	IR13014535	NA4826
172	216 000	540 000	2 500	2 360	IR13015050	NA4926
168.5	121 000	363 000	2 500	1 170	IR14015535	NA4828
182	224 000	580 000	2 500	2 500	IR14016050	NA4928
183.5	168 000	446 000	2 500	1 750	IR15016540	NA4830
193.5	173 000	474 000	2 500	1 850	IR16017540	NA4832

* Suitable for oil lubrication. In case of grease lubrication, down to 60% of this value.

MACHINED RING NEEDLE ROLLER BEARINGS WITH INNER RING

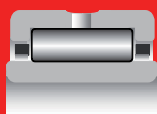

NA, NKI



■ NA49,NA59,NA69,NA48,NKI TYPE

Shaft Diameter (mm)	Designation					Dimensions (mm)			
	NA 49	NA 59	NA 69	NA 48	NKI	d	D	C	
5	NA495 — —	— — —	— — —	— — —	— NKI 5/12 NKI 5/16	5 5 ⁰ 5 ^{-0.008}	13 15 15	10 12 16	
6	NA 496 — —	— — —	— — —	— — —	— NKI 6/12 NKI 6/16	6 6 ⁰ 6 ^{-0.008}	15 16 16	10 12 16	
7	NA 497 — —	— — —	— — —	— — —	— NKI 7/12 NKI 7/16	7 7 ⁰ 7 ^{-0.008}	17 17 17	10 12 16	
8	NA 498	—	—	—	—	8 ⁰ 8 ^{-0.008}	19	11	
9	— — NA 499	— — —	— — —	— — —	NKI 9/12 NKI 9/16 —	9 9 ⁰ 9 ^{-0.008}	19 19 20	12 16 11	
10	NA 4900 — —	— — —	— — —	— — —	— NKI 10/16 NKI 10/20	10 10 ⁰ 10 ^{-0.008}	22 22 22	13 16 20	
12	NA 4901 — — —	— — — —	— — — NA 6901	— — — —	— NKI 12/16 NKI 12/20 —	12 12 ⁰ 12 ^{-0.008} 12	24 24 24 24	13 16 20 22	

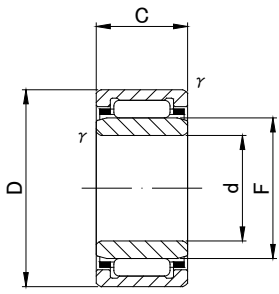

NKI($d \leq 8$)

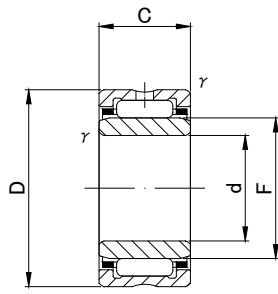

NA49,NA59,NA69($d \leq 30$),NKI

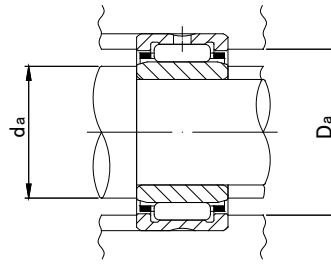

NA, NKI



		Standard mounting dimensions (mm)			Basic dynamic load rating	Basic static load rating	Limiting speed*	Mass	Usable bearing designation	
f's min	F	da		Da MAX	Cr N	Cor N	rpm	g (approx)	OUTER RING	INNER RING
		MIN	MAX							
0.15	7	6.2	6.7	11.8	2 960	2 690	34 000	7.3	RNA495	IR5710
0.3	8	7	7.7	13	5 100	4 700	32 000	11.9	NK8/12	IR5812
0.3	8	7	7.7	13	7 100	7 300	32 000	16.7	NK8/16	IR5816
0.15	8	7.2	7.7	13.8	3 900	3 400	32 000	9.1	RNA496	IR6810
0.3	9	8	8.7	14	5 500	5 300	30 000	13	NK9/12	IR6912
0.3	9	8	8.7	14	7 600	8 200	30 000	17.5	NK9/16	IR6916
0.15	9	8.2	8.7	15.8	4 500	3 600	30 000	11.2	RNA497	IR7910
0.3	10	9	9.7	15	5 900	6 000	28 000	14.3	NK10/12	IR71012
0.3	10	9	9.7	15	8 200	9 200	28 000	19.2	NK10/16	IR71016
0.2	10	9.2	9.7	17.4	6 200	5 000	28 000	15	RNA498	IR81011
0.3	12	11	11.5	17	6 600	7 300	26 000	16.7	NK12/12	IR91212
0.3	12	11	11.5	17	9 200	11 200	26 000	22.5	NK12/16	IR91216
0.3	12	11	11.5	18	6 600	6 300	26 000	16.7	RNA499	IR91211
0.3	14	12	13	20	9 200	10 100	24 000	24	RNA4900	IR101413
0.3	14	12	13	20	11 800	13 700	24 000	30	NK14/16	IR101416
0.3	14	12	13	20	14 800	18 500	24 000	38	NK14/20	IR101420
0.3	16	14	15	22	9 700	11 100	23 000	26.5	RNA4901	IR121613
0.3	16	14	15	22	12 300	15 100	23 000	33.5	NK16/16	IR121616
0.3	16	14	15	22	15 600	20 400	23 000	42.5	NK16/20	IR121620
0.3	16	14	15	22	17 100	23 000	23 000	44.5	RNA6901	IR121622

* Suitable for oil lubrication. In case of grease lubrication, down to 60% of this value.

MACHINED RING NEEDLE ROLLER BEARINGS WITH INNER RING

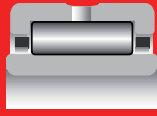

NA, NKI



■ NA49,NA59,NA69,NA48,NKI TYPE

Shaft Diameter (mm)	Designation					Dimensions (mm)			
	NA 49	NA 59	NA 69	NA 48	NKI	d	D	C	
15	— — NA 4902 — —	— — — NA 5902 —	— — — — NA 6902	— — — — —	NKI 15/16 NKI 15/20 — — —	15 15 15 ⁰ _{-0.008} 15 15	27 27 28 28 28	16 20 13 18 23	
17	— — NA 4903 — —	— — — NA 5903 —	— — — — NA 6903	— — — — —	NKI 17/16 NKI 17/20 — — —	17 17 17 ⁰ _{-0.008} 17 17	29 29 30 30 30	16 20 13 18 23	
20	— — NA 4904 — —	— — — NA 5904 —	— — — — NA 6904	— — — — —	NKI 20/16 NKI 20/20 — — —	20 20 20 ⁰ _{-0.010} 20 20	32 32 37 37 37	16 20 17 23 30	
22	— — NA 49/22 — —	— — — NA 59/22 —	— — — — NA 69/22	— — — — —	NKI 22/16 NKI 22/20 — — —	22 22 22 ⁰ _{-0.010} 22 22	34 34 39 39 39	16 20 17 23 30	
25	— — NA 4905 — —	— — — NA 5905 —	— — — — NA 6905	— — — — —	NKI 25/20 NKI 25/30 — — —	25 25 25 ⁰ _{-0.010} 25 25	38 38 42 42 42	20 30 17 23 30	
28	— — NA 49/28 — —	— — — NA 59/28 —	— — — — NA 69/28	— — — — —	NKI 28/20 NKI 28/30 — — —	28 28 28 ⁰ _{-0.010} 28 28	42 42 45 45 45	20 30 17 23 30	
30	— — NA 4906 — —	— — — NA 5906 —	— — — — NA 6906	— — — — —	NKI 30/20 NKI 30/30 — — —	30 30 30 ⁰ _{-0.010} 30 30	45 45 47 47 47	20 30 17 23 30	

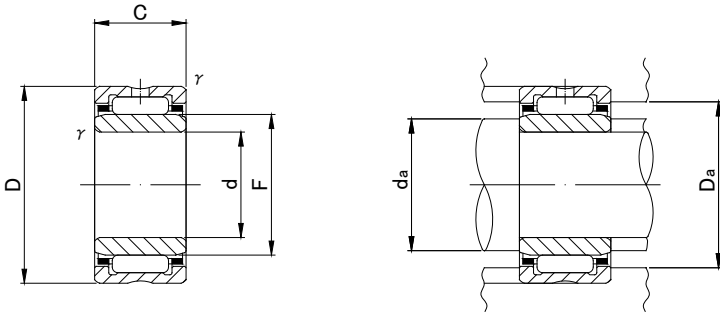

NA49,NA59,NA69($d \leq 30$),NKI



		Standard mounting dimensions (mm)			Basic dynamic load rating	Basic static load rating	Limiting speed*	Mass	Usable bearing designation	
r/s min	F	da		Da	Cr	Cor	rpm	g (approx)	OUTER RING	INNER RING
		MIN	MAX	MAX	N	N				
0.3	19	17	18	25	14 000	18 700	21 000	39.5	NK19/16	IR151916
0.3	19	17	18	25	17 700	25 300	21 000	50	NK19/20	IR151920
0.3	20	17	19	26	10 900	13 800	20 000	35	RNA4902	IR152013
0.3	20	17	19	26	15 700	22 100	20 000	52	RNA5902	IR152018
0.3	20	17	19	26	19 300	28 700	20 000	61	RNA6902	IR152023
0.3	21	19	20	27	14 400	20 000	19 000	43.5	NK21/16	IR172116
0.3	21	19	20	27	18 200	27 100	19 000	54	NK21/20	IR172120
0.3	22	19	21	28	11 800	15 600	18 000	39	RNA4903	IR172213
0.3	22	19	21	28	16 900	24 900	18 000	56	RNA5903	IR172218
0.3	22	19	21	28	20 800	32 500	18 000	67	RNA6903	IR172223
0.3	24	22	23	30	15 300	22 600	17 000	48.5	NK24/16	IR202416
0.3	24	22	23	30	19 400	30 500	17 000	61	NK24/20	IR202420
0.3	25	22	24	35	21 000	25 000	16 000	78.5	RNA4904	IR202517
0.3	25	22	24	35	29 400	38 600	16 000	115	RNA5904	IR202523
0.3	25	22	24	35	35 400	48 800	16 000	136	RNA6904	IR202530
0.3	26	24	25	32	16 300	24 900	15 000	52	NK26/16	IR222616
0.3	26	24	25	32	20 600	33 700	15 000	67.5	NK26/20	IR222620
0.3	28	24	27	37	21 400	28 800	14 000	87	RNA49/22	IR222817
0.3	28	24	27	37	29 800	44 400	14 000	134	RNA59/22	IR222823
0.3	28	24	27	37	36 300	56 900	14 000	152	RNA69/22	IR222830
0.3	29	27	28	36	21 600	37 200	14 000	82	NK29/20	IR252920
0.3	29	27	28	36	30 900	59 000	14 000	123	NK29/30	IR252930
0.3	30	27	29	40	23 700	30 700	13 000	92.5	RNA4905	IR253017
0.3	30	27	29	40	33 200	47 500	13 000	139	RNA5905	IR253023
0.3	30	27	29	40	42 100	64 200	13 000	160	RNA6905	IR253030
0.3	32	30	31	40	25 700	42 200	13 000	96.5	NK32/20	IR283220
0.3	32	30	31	40	36 900	67 100	13 000	145	NK32/30	IR283230
0.3	32	30	31	43	24 500	32 700	13 000	101	RNA49/28	IR283217
0.3	32	30	31	43	34 300	50 500	13 000	142	RNA59/28	IR283223
0.3	32	30	31	43	41 800	64 700	13 000	176	RNA69/28	IR283230
0.3	35	32	34	43	27 000	46 200	11 000	112	NK35/20	IR303520
0.3	35	32	34	43	38 600	73 500	11 000	171	NK35/30	IR303530
0.3	35	32	34	45	25 200	34 700	11 000	106	RNA4906	IR303517
0.3	35	32	34	45	35 200	53 700	11 000	152	RNA5906	IR303523
0.3	35	32	34	45	43 100	69 000	11 000	184	RNA6906	IR303530

* Suitable for oil lubrication. In case of grease lubrication, down to 60% of this value.

MACHINED RING NEEDLE ROLLER BEARINGS WITH INNER RING

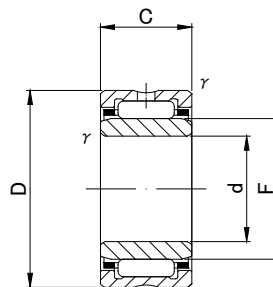
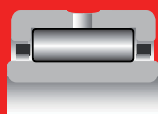

NA49,NA59,NA69(d ≤ 30),NKI

NA, NKI

NA49,NA59,NA69,NA48,NKI TYPE

Shaft Diameter (mm)	Designation					Dimensions (mm)			
	NA 49	NA 59	NA 69	NA48	NKI	d	D	C	
32	— — NA 49/32 — —	— — — NA 59/32 —	— — — — NA 69/32	— — — — —	NKI 32/20 NKI 32/30 — — —	32 32 32 ⁰ _{-0.012} 32 32	47 47 52 52 52	20 30 20 27 36	
35	— — NA 4907 — —	— — — NA 5907 —	— — — — NA 6907	— — — — —	NKI 35/20 NKI 35/30 — — —	35 35 35 ⁰ _{-0.012} 35 35	50 50 55 55 55	20 30 20 27 36	
38	— —	— —	— —	— —	NKI 38/20 NKI 38/30	38 ⁰ 38 _{-0.012}	53 53	20 30	
40	— — NA 4908 — —	— — — NA 5908 —	— — — — NA 6908	— — — — —	NKI 40/20 NKI 40/30 — — —	40 40 40 ⁰ _{-0.012} 40 40	55 55 62 62 62	20 30 22 30 40	
42	— —	— —	— —	— —	NKI 42/20 NKI 42/30	42 ⁰ 42 _{-0.012}	57 57	20 30	
45	— — NA 4909 — —	— — — NA 5909 —	— — — — NA 6909	— — — — —	NKI 45/25 NKI 45/35 — — —	45 45 45 ⁰ _{-0.012} 45 45	62 62 68 68 68	25 35 22 30 40	
50	— — NA 4910 — —	— — — NA 5910 —	— — — — NA 6910	— — — — —	NKI 50/25 NKI 50/35 — — —	50 50 50 ⁰ _{-0.012} 50 50	68 68 72 72 72	25 35 22 30 40	

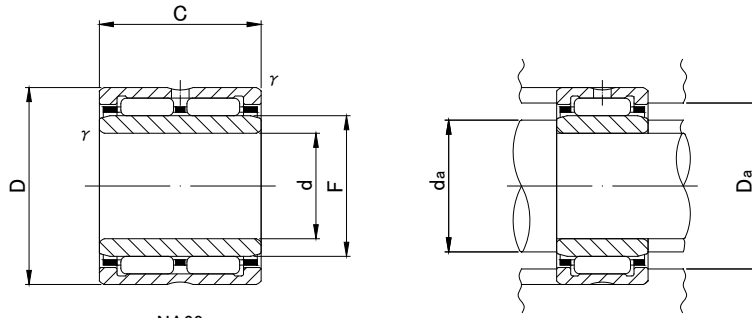

NA69



		Standard mounting dimensions (mm)			Basic dynamic load rating	Basic static load rating	Limiting speed*	Mass	Usable bearing designation	
r/s min	F	da		Da	Cr	Cor	rpm	g (approx)	OUTER RING	INNER RING
		MIN	MAX	MAX	N	N				
0.3	37	34	36	45	28 200	50 100	11 000	121	NK37/20	IR323720
0.3	37	34	36	45	40 500	79 800	11 000	180	NK37/30	IR323730
0.6	40	36	39	48	31 300	47 900	10 000	165	RNA49/32	IR324020
0.6	40	36	39	48	41 900	69 900	10 000	241	RNA59/32	IR324027
0.6	40	36	39	48	53 500	95 700	10 000	295	RNA69/32	IR324036
0.3	40	37	39	48	29 400	54 100	10 000	129	NK40/20	IR354020
0.3	40	37	39	48	42 300	86 100	10 000	192	NK40/30	IR354030
0.6	42	39	41	51	32 000	50 200	9 500	178	RNA4907	IR354220
0.6	42	39	41	51	42 900	73 200	9 500	256	RNA5907	IR354227
0.6	42	39	41	51	54 800	100 000	9 500	320	RNA6907	IR354236
0.3	43	40	42	51	30 500	58 100	9 500	136	NK43/20	IR384320
0.3	43	40	42	51	43 700	92 500	9 500	205	NK43/30	IR384330
0.3	45	42	44	53	31 100	60 100	9 000	143	NK45/20	IR404520
0.3	45	42	44	53	44 500	95 700	9 000	215	NK45/30	IR404530
0.6	48	44	47	58	41 600	67 400	8 500	245	RNA4908	IR404822
0.6	48	44	47	58	58 000	103 000	8 500	348	RNA5908	IR404830
0.6	48	44	47	58	71 300	134 400	8 500	440	RNA6908	IR404840
0.3	47	44	46	55	31 500	62 300	8 500	149	NK47/20	IR424720
0.3	47	44	46	55	45 200	99 000	8 500	225	NK47/30	IR424730
0.6	50	49	49.5	58	43 000	85 200	8 000	230	NK50/25	IR455025
0.6	50	49	49.5	58	58 100	125 500	8 000	320	NK50/35	IR455035
0.6	52	49	51	64	43 500	73 400	7 500	285	RNA4909	IR455222
0.6	52	49	51	64	60 700	112 000	7 500	396	RNA5909	IR455230
0.6	52	49	51	64	74 600	147 100	7 500	520	RNA6909	IR455240
0.6	55	54	54.5	64	45 400	94 100	7 500	270	NK55/25	IR505525
0.6	55	54	54.5	64	61 300	138 300	7 500	365	NK55/35	IR505535
0.6	58	54	57	68	46 200	82 100	7 000	295	RNA4910	IR505822
0.6	58	54	57	68	64 400	126 000	7 000	498	RNA5910	IR505830
0.6	58	54	57	68	79 100	163 800	7 000	530	RNA6910	IR505840

* Suitable for oil lubrication. In case of grease lubrication, down to 60% of this value.

MACHINED RING NEEDLE ROLLER BEARINGS WITH INNER RING

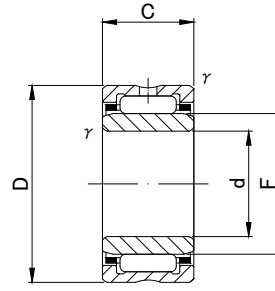
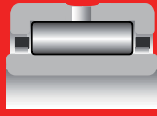

NA49,NA59,NKI

■ NA49,NA59,NA69,NA48,NKI TYPE

Shaft Diameter (mm)	Designation					Dimensions (mm)			
	NA 49	NA 59	NA 69	NA48	NKI	d	D	C	
55	— — NA 4911 — —	— — — NA 5911 —	— — — — NA 6911	— — — — —	NKI 55/25 NKI 55/35 — — —	55 55 55 ⁰ _{-0.015} 55 55	72 72 80 80 80	25 35 25 34 45	
60	— — NA 4912 — —	— — — NA 5912 —	— — — — NA 6912	— — — — —	NKI 60/25 NKI 60/35 — — —	60 60 60 ⁰ _{-0.015} 60 60	82 82 85 85 85	25 35 25 34 45	
65	NA 4913 — — —	— NA 5913 — —	— — — NA 6913	— — — —	— — NKI 65/35 —	65 65 ⁰ _{-0.015} 65 65	90 90 90 90	25 34 35 45	
70	— — NA 4914 — —	— — — NA 5914 —	— — — — NA 6914	— — — — —	NKI 70/25 NKI 70/35 — — —	70 70 70 ⁰ _{-0.015} 70 70	95 95 100 100 100	25 35 30 40 54	
75	— NA 4915 — — —	— — — NA 5915 —	— — — — NA 6915	— — — — —	NKI 75/25 — NKI 75/35 — —	75 75 75 ⁰ _{-0.015} 75 75	105 105 105 105 105	25 30 35 40 54	
80	— NA 4916 — — —	— — — NA 5916 —	— — — — NA 6916	— — — — —	NKI 80/25 — NKI 80/35 — —	80 80 80 ⁰ _{-0.015} 80 80	110 110 110 110 110	25 30 35 40 54	
85	— — NA 4917 — —	— — — NA 5917 —	— — — — NA 6917	— — — — —	NKI 85/26 NKI 85/36 — — —	85 85 85 ⁰ _{-0.020} 85 85	115 115 120 120 120	26 36 35 46 63	

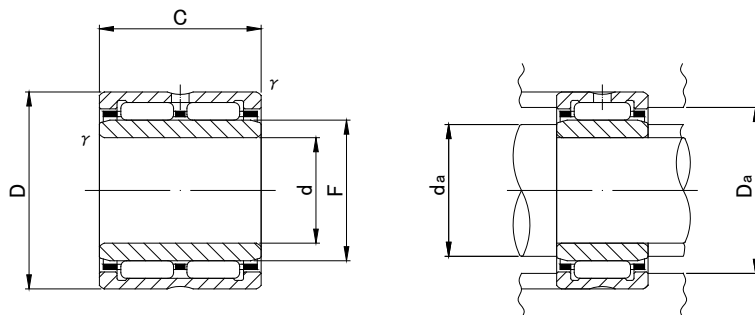

NA69

NA, NKI



		Standard mounting dimensions (mm)			Basic dynamic load rating	Basic static load rating	Limiting speed*	Mass	Usable bearing designation	
/s min	F	da		Da	Cr	Cor	rpm	g (approx)	OUTER RING	INNER RING
		MIN	MAX	MAX	N	N				
0.6	60	59	59.5	68	47 500	103 000	6 500	275	NK60/25	IR556025
0.6	60	59	59.5	68	64 100	151 000	6 500	380	NK60/35	IR556035
1	63	60	61	75	57 600	97 300	6 500	410	RNA4911	IR556325
1	63	60	61	75	82 600	154 000	6 500	559	RNA5911	IR556334
1	63	60	61	75	99 000	194 200	6 500	730	RNA6911	IR556345
0.6	68	64	66	78	54 800	116 700	6 000	395	NK68/25	IR606825
0.6	68	64	66	78	72 100	165 700	6 000	560	NK68/35	IR606835
1	68	64	66	80	60 100	104 900	6 000	440	RNA4912	IR606825
1	68	65	66	80	86 100	167 000	6 000	614	RNA5912	IR606834
1	68	65	66	80	103 000	210 800	6 000	785	RNA6912	IR606845
1	72	70	70.5	85	62 800	113 800	5 500	470	RNA4913	IR657225
1	72	70	70.5	85	89 900	180 000	5 500	655	RNA5913	IR657234
0.6	73	69	71	86	80 400	180 400	5 500	710	NK73/35	IR657335
1	72	70	70.5	85	107 900	226 500	5 500	840	RNA6913	IR657245
1	80	75	78	90	59 400	137 300	5 000	540	NK80/25	IR708025
1	80	75	78	90	78 100	194 200	5 000	755	NK80/35	IR708035
1	80	75	78	95	83 200	157 900	5 000	765	RNA4914	IR708030
1	80	75	78	95	112 000	232 000	5 000	1 060	RNA5914	IR708040
1	80	75	78	95	133 400	310 900	5 000	1 400	RNA6914	IR708054
1	85	80	83	100	76 400	145 100	4 500	675	NK85/25	IR758525
1	85	80	83	100	86 200	169 700	4 500	810	RNA4915	IR758530
1	85	80	83	100	102 000	209 900	4 500	945	NK85/35	IR758535
1	85	80	83	100	116 000	249 000	4 500	1 130	RNA5915	IR758540
1	85	80	83	100	138 300	330 500	4 500	1 480	RNA6915	IR758554
1	90	85	88	105	77 400	150 000	4 500	710	NK90/25	IR809025
1	90	85	88	105	87 400	174 600	4 500	855	RNA4916	IR809030
1	90	85	88	105	103 000	216 700	4 500	995	NK90/35	IR809035
1	90	85	88	105	117 000	257 000	4 500	1 150	RNA5916	IR809040
1	90	85	88	105	143 200	350 100	4 500	1 560	RNA6916	IR809054
1	95	90	93	110	79 700	158 900	4 200	775	NK95/26	IR859526
1	95	90	93	110	106 900	230 500	4 200	1 080	NK95/36	IR859536
1.1	100	91.5	98	133.5	109 800	244 200	4 000	1 280	RNA4917	IR8510035
1.1	100	91.5	98	133.5	144 000	346 000	4 000	1 760	RNA5917	IR8510046
1.1	100	91.5	98	133.5	172 600	466 800	4 000	2 340	RNA6917	IR8510063

* Suitable for oil lubrication. In case of grease lubrication, down to 60% of this value.

MACHINED RING NEEDLE ROLLER BEARINGS WITH INNER RING

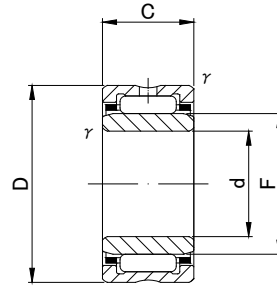
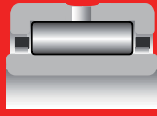

NA49,NA59,NA48,NKI

NA49,NA59,NA69,NA48,NKI TYPE

Shaft Diameter (mm)	Designation					Dimensions (mm)			
	NA 49	NA 59	NA 69	NA 48	NKI	d	D	C	
90	— — NA 4918 — —	— — — NA 5918 —	— — — — NA 6918	— — — — —	NKI 90/26 NKI 90/36 — — —	90 90 90 ⁰ _{-0.020} 90 90	120 120 125 125 125	26 36 35 46 63	
95	— — NA 4919 — —	— — — — NA 5919 —	— — — — — NA 6919	— — — — —	NKI 95/26 NKI 95/36 — — —	95 95 95 ⁰ _{-0.020} 95 95	125 125 130 130 130	26 36 35 46 63	
100	— — NA 4920	— — —	— — —	— — —	NKI 100/30 NKI 100/40 —	100 100 ⁰ _{-0.020} 100	130 130 140	30 40 40	
110	— NA 4922	— —	— —	NA 4822 —	— —	110 ⁰ _{-0.020} 110	140 150	30 40	
120	— NA 4924	— —	— —	NA 4824 —	— —	120 ⁰ _{-0.020} 120	150 165	30 45	
130	— NA 4926	— —	— —	NA 4826 —	— —	130 ⁰ _{-0.025} 130	165 180	35 50	
140	— NA 4928	— —	— —	NA 4828 —	— —	140 ⁰ _{-0.025} 140	175 190	35 50	
150	—	—	—	NA 4830	—	150 ⁰ _{-0.025}	190	40	
160	—	—	—	NA 4832	—	160 ⁰ _{-0.025}	200	40	

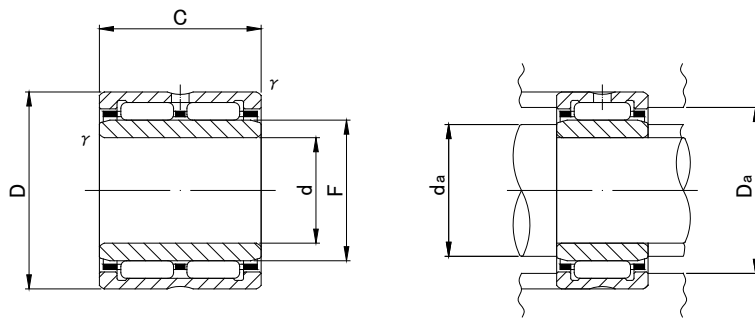

NA69



		Standard mounting dimensions (mm)			Basic dynamic load rating	Basic static load rating	Limiting speed*	Mass	Usable bearing designation	
/s min	F	da		Da	Cr	Cor	rpm	g (approx)	OUTER RING	INNER RING
		MIN	MAX	MAX	N	N				
1	100	95	98	135	82 500	168 700	4 000	820	NK100/26	IR9010026
1	100	95	98	135	109 800	244 200	4 000	1 140	NK100/36	IR9010036
1.1	105	96.5	103	118.5	112 800	257 900	3 800	1 350	RNA4918	IR9010535
1.1	105	96.5	103	118.5	148 000	365 000	3 800	1 840	RNA5918	IR9010546
1.1	105	96.5	103	118.5	177 500	490 300	3 800	2 460	RNA6918	IR9010563
1	105	100	103	120	84 700	177 500	3 800	860	NK105/26	IR9510526
1	105	100	103	120	112 800	257 900	3 800	1 190	NK105/36	IR9510536
1.1	110	101.5	108	123.5	116 700	270 700	3 600	1 420	RNA4919	IR9511035
1.1	110	101.5	108	123.5	152 000	384 000	3 600	1 980	RNA5919	IR9511046
1.1	110	101.5	108	123.5	182 400	514 800	3 600	2 580	RNA6919	IR9511063
1.1	110	106.5	108	123.5	105 900	239 300	3 600	1 040	NK110/30	IR10011030
1.1	110	106.5	108	123.5	133 400	323 600	3 600	1 380	NK110/40	IR10011040
1.1	115	106.5	113	133.5	145 000	329 000	3 500	1 960	RNA4920	IR10011540
1	120	115	118	135	93 000	239 000	3 500	1 200	RNA4822	IR11012030
1.1	125	116.5	123	143.5	152 000	357 000	3 000	2 120	RNA4922	IR11012540
1	130	125	128	145	97 000	259 000	3 000	1 300	RNA4824	IR12013030
1.1	135	126.5	133	158.5	187 000	435 000	3 000	2 960	RNA4924	IR12013545
1.1	145	136.5	143	158.5	117 000	340 000	3 000	1 960	RNA4826	IR13014535
1.5	150	138	148	172	216 000	540 000	2 500	4 030	RNA4926	IR13015050
1.1	155	146.5	153	168.5	121 000	363 000	2 500	2 100	RNA4828	IR14015535
1.5	160	148	158	182	224 000	580 000	2 500	4 290	RNA4928	IR14016050
1.1	165	156.5	163	183.5	168 000	446 000	2 500	2 880	RNA4830	IR15016540
1.1	175	166.5	173	193.5	173 000	474 000	2 500	3 050	RNA4832	IR16017540

* Suitable for oil lubrication. In case of grease lubrication, down to 60% of this value.

MACHINED RING NEEDLE ROLLER BEARINGS

SEALED, WITHOUT INNER RING

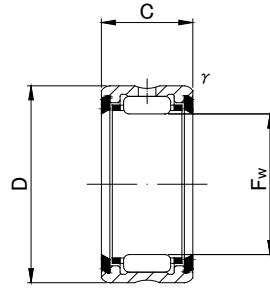
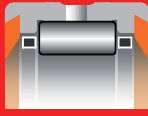

RNA49UU, RNA69UU ($F_w \leq 35$)

RNA49UU, RNA69UU, SEALED TYPE

Shaft Diameter (mm)	Designation		Dimensions (mm)				Standard mounting dimensions (mm)
	RNA 49UU	RNA 69UU	F_w	D	C	r_s min	Da MAX
14	RNA 4900UU	—	14 $+0.027$ 14 $+0.016$	22	13	0.3	20
16	RNA 4901UU	—	16 $+0.027$	24	13	0.3	22
	—	RNA 6901UU	16 $+0.016$	24	22	0.3	22
20	RNA 4902UU	—	20 $+0.033$	28	13	0.3	26
	—	RNA 6902UU	20 $+0.020$	28	23	0.3	26
22	RNA 4903UU	—	22 $+0.033$	30	13	0.3	28
	—	RNA 6903UU	22 $+0.020$	30	23	0.3	28
25	RNA 4904UU	—	25 $+0.033$	37	17	0.3	35
	—	RNA 6904UU	25 $+0.020$	37	30	0.3	35
30	RNA 4905UU	—	30 $+0.033$	42	17	0.3	40
	—	RNA 6905UU	30 $+0.020$	42	30	0.3	40
35	RNA 4906UU	—	35 $+0.041$	47	17	0.3	45
	—	RNA 6906UU	35 $+0.025$	47	30	0.3	45
42	RNA 4907UU	—	42 $+0.041$	55	20	0.6	51
	—	RNA 6907UU	42 $+0.025$	55	36	0.6	51
48	RNA 4908UU	—	48 $+0.041$	62	22	0.6	58
	—	RNA 6908UU	48 $+0.025$	62	40	0.6	58
52	RNA 4909UU	—	52 $+0.049$	68	22	0.6	64
	—	RNA 6909UU	52 $+0.030$	68	40	0.6	64
58	RNA 4910UU	—	58 $+0.049$	72	22	0.6	68
	—	RNA 6910UU	58 $+0.030$	72	40	0.6	68

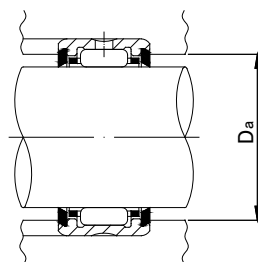
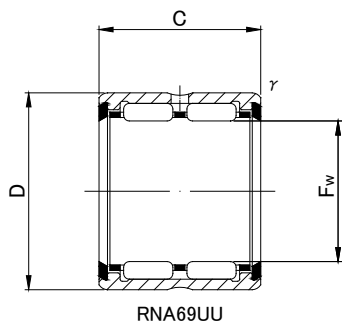

RNA69UU

Prepacked Grease

Basic dynamic load rating	Basic static load rating	Limiting speed (GREASE)	Mass	Usable bearing designation	
				INNER RING	WITH INNER RING
Cr N	Cor N	rpm	g (approx)		
8 000	8 500	14 000	16	IRZ101414	NA4900UU
8 400 15 600	9 300 20 400	12 000 12 000	18 30	IRZ121614 IRZ121623	NA4901UU NA6901UU
9 600 18 400	11 700 27 100	9 500 9 500	22 38	IRZ152014 IRZ152024	NA4902UU NA6902UU
10 300 19 800	13 100 30 600	8 500 8 500	23 40	IRZ172214 IRZ172224	NA4903UU NA6903UU
17 900 33 000	20 500 44 500	7 500 7 500	55 96	IRZ202518 IRZ202531	NA4904UU NA6904UU
20 300 39 200	25 100 58 600	6 500 6 500	63 110	IRZ253018 IRZ253031	NA4905UU NA6905UU
21 600 40 100	28 400 63 100	5 500 5 500	71 130	IRZ303518 IRZ303531	NA4906UU NA6906UU
30 100 51 600	46 300 92 600	4 500 4 500	110 200	IRZ354221 IRZ354237	NA4907UU NA6907UU
37 200 63 700	58 300 116 700	4 000 4 000	150 270	IRZ404823 IRZ404841	NA4908UU NA6908UU
38 800 66 700	63 400 126 500	3 500 3 500	190 355	IRZ455223 IRZ455241	NA4909UU NA6909UU
41 300 70 800	71 100 142 200	3 500 3 500	180 320	IRZ505823 IRZ505841	NA4910UU NA6910UU

RNA UU



MACHINED RING NEEDLE ROLLER BEARINGS

SEALED, WITH INNER RING

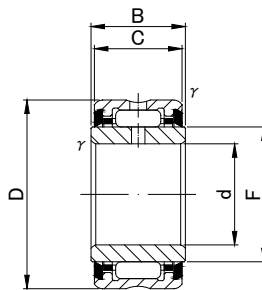
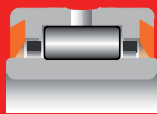

NA49UU,NA69UU($d \leq 30$)

NA UU



NA49UU,NA69UU,SEALED TYPE

Shaft Diameter (mm)	Designation		Dimensions (mm)					
	NA 49UU	NA 69UU	d	D	C	B	r/s min	F
10	NA 4900UU	—	10 ⁰ _{-0.008}	22	13	14	0.3	14
12	NA 4901UU —	— NA 6901UU	12 ⁰ _{-0.008} 12	24 24	13 22	14 23	0.3 0.3	16 16
15	NA 4902UU —	— NA 6902UU	15 ⁰ _{-0.008} 15	28 28	13 23	14 24	0.3 0.3	20 20
17	NA 4903UU —	— NA 6903UU	17 ⁰ _{-0.008} 17	30 30	13 23	14 24	0.3 0.3	22 22
20	NA 4904UU —	— NA 6904UU	20 ⁰ _{-0.010} 20	37 37	17 30	18 31	0.3 0.3	25 25
25	NA 4905UU —	— NA 6905UU	25 ⁰ _{-0.010} 25	42 42	17 30	18 31	0.3 0.3	30 30
30	NA 4906UU —	— NA 6906UU	30 ⁰ _{-0.010} 30	47 47	17 30	18 31	0.3 0.3	35 35
35	NA 4907UU —	— NA 6907UU	35 ⁰ _{-0.012} 35	55 55	20 36	21 37	0.6 0.6	42 42
40	NA 4908UU —	— NA 6908UU	40 ⁰ _{-0.012} 40	62 62	22 40	23 41	0.6 0.6	48 48
45	NA 4909UU —	— NA 6909UU	45 ⁰ _{-0.012} 45	68 68	22 40	23 41	0.6 0.6	52 52
50	NA 4910UU —	— NA 6910UU	50 ⁰ _{-0.012} 50	72 72	22 40	23 41	0.6 0.6	58 58

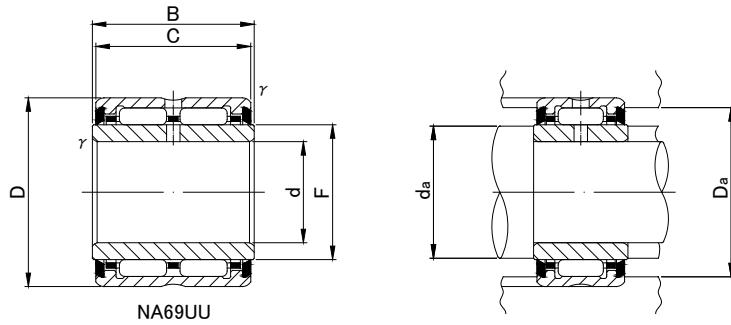

NA69UU

Prepacked Grease



Standard mounting dimensions (mm)		Basic dynamic load rating	Basic static load rating	Limiting speed (GREASE)	Mass	Usable bearing designation		
da		Da MAX	Cr N	Cor N	rpm	g (approx)	OUTER RING	INNER RING
MIN	MAX							
12	13	20	8 000	8 500	14 000	25	RNA4900UU	IRZ101414
14	15	22	8 400	9 300	12 000	28	RNA4901UU	IRZ121614
14	15	22	15 600	20 400	12 000	46	RNA6901UU	IRZ121623
17	19	26	9 600	11 700	9 500	36	RNA4902UU	IRZ152014
17	19	26	18 400	27 100	9 500	63	RNA6902UU	IRZ152024
19	21	28	10 300	13 100	8 500	40	RNA4903UU	IRZ172214
19	21	28	19 800	30 600	8 500	69	RNA6903UU	IRZ172224
22	24	35	17 900	20 500	7 500	78	RNA4904UU	IRZ202518
22	24	35	33 000	44 500	7 500	140	RNA6904UU	IRZ202531
27	29	40	20 300	25 100	6 500	93	RNA4905UU	IRZ253018
27	29	40	39 200	58 600	6 500	162	RNA6905UU	IRZ253031
32	34	45	21 600	28 400	5 500	106	RNA4906UU	IRZ303518
32	34	45	40 100	63 100	5 500	185	RNA6906UU	IRZ303531
39	41	51	30 100	46 300	4 500	179	RNA4907UU	IRZ354221
39	41	51	51 600	92 600	4 500	320	RNA6907UU	IRZ354237
44	47	58	37 200	58 300	4 000	245	RNA4908UU	IRZ404823
44	47	58	63 700	116 700	4 000	440	RNA6908UU	IRZ404841
49	51	64	38 800	63 400	3 500	290	RNA4909UU	IRZ455223
49	51	64	66 700	126 500	3 500	510	RNA6909UU	IRZ455241
54	57	68	41 300	71 100	3 500	300	RNA4910UU	IRZ505823
54	57	68	70 800	142 200	3 500	530	RNA6910UU	IRZ505841

MACHINED RING NEEDLE ROLLER BEARINGS WITHOUT INNER RING

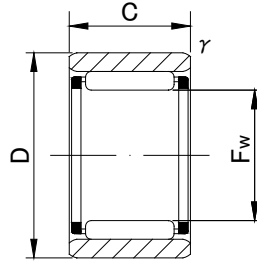
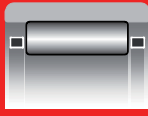

RNAF

RNAF(W)



RNAF(W) TYPE

Shaft Diameter (mm)	Designation	Dimensions (mm)				Standard mounting dimensions (mm)		
		Fw	D	C	r/s min	db	Da MAX	Db
5	RNAF5108	5 ^{+0.018} / _{+0.010}	10	8	0.2	6.7	8.4	5.4
6	RNAF6138	6 ^{+0.018} / _{+0.010}	13	8	0.3	8.4	11	6.4
7	RNAF7148	7 ^{+0.022} / _{+0.013}	14	8	0.3	9.4	12	7.4
8	RNAF81510	8 ^{+0.022} / _{+0.013}	15	10	0.3	10.4	13	8.4
	RNAFW81620	8 ^{+0.022} / _{+0.013}	16	20	0.3	10.8	14	8.4
10	RNAF101710	10 ^{+0.022} / _{+0.013}	17	10	0.3	12.4	15	10.4
	RNAF102012	10 ^{+0.022} / _{+0.013}	20	12	0.3	13.5	18	10.4
12	RNAF122212	12 ^{+0.027} / _{+0.016}	22	12	0.3	17.5	20	12.4
14	RNAF142213	14 ^{+0.027} / _{+0.016}	22	13	0.3	17.6	20	14.6
	RNAFW142220	14 ^{+0.027} / _{+0.016}	22	20	0.3	17.6	20	14.6
	RNAF142612	14 ^{+0.027} / _{+0.016}	26	12	0.3	19.4	24	14.6
15	RNAF152313	15 ^{+0.027} / _{+0.016}	23	13	0.3	18.6	21	15.6
	RNAFW152320	15 ^{+0.027} / _{+0.016}	23	20	0.3	18.6	21	15.6
16	RNAF162413	16 ^{+0.027} / _{+0.016}	24	13	0.3	19.6	22	16.6
	RNAFW162420	16 ^{+0.027} / _{+0.016}	24	20	0.3	19.6	22	16.6
	RNAF162812	16 ^{+0.027} / _{+0.016}	28	12	0.3	21.4	26	16.6
17	RNAF172513	17 ^{+0.027} / _{+0.016}	25	13	0.3	20.6	23	17.6
	RNAFW172520	17 ^{+0.027} / _{+0.016}	25	20	0.3	20.6	23	17.6
18	RNAF182613	18 ^{+0.027} / _{+0.016}	26	13	0.3	21.6	24	18.6
	RNAFW182620	18 ^{+0.027} / _{+0.016}	26	20	0.3	21.6	24	18.6
	RNAF183012	18 ^{+0.027} / _{+0.016}	30	12	0.3	23.4	28	18.6
	RNAFW183024	18 ^{+0.027} / _{+0.016}	30	24	0.3	23.4	28	18.6

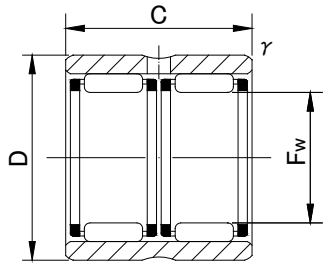

RNAFW

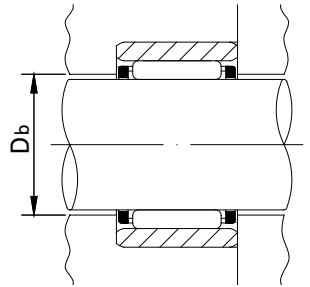
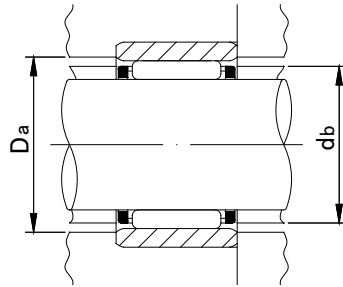

Basic dynamic load rating	Basic static load rating	Limiting speed*	Mass	Usable bearing designation	
				INNER RING	WITH INNER RING
Cr N	Cor N	rpm	g (approx)	INNER RING	WITH INNER RING
2 500	2 000	40 000	3	—	—
2 500	2 100	37 000	5.5	—	—
2 900	2 600	34 000	6	—	—
3 600 6 200	3 600 7 200	32 000 32 000	8 20	— —	— —
4 100 6 000	4 500 6 000	28 000 28 000	10 19	IR61010 IR71012	NAF61710 NAF72012
9 000	8 400	26 000	19	IR91212	NAF92212
7 800 10 800 9 800	9 400 14 200 9 700	24 000 24 000 24 000	18 28 29	IR101413 IR101420 IR101412	NAF102213 NAFW102220 NAF102612
8 200 11 400	10 200 15 400	23 000 23 000	20 31	— —	— —
8 600 11 900 10 500	11 000 16 700 10 900	23 000 23 000 23 000	21 32 32	IR121613 IR121620 IR121612	NAF122413 NAFW122420 NAF122812
9 000 12 400	11 900 17 900	22 000 22 000	22 33	— —	— —
9 300 12 800 11 800 20 200	12 700 19 100 13 000 26 200	21 000 21 000 21 000 21 000	23 35 35 70	— — — —	— — — —

* Suitable for oil lubrication. In case of grease lubrication, down to 50% of this value.

MACHINED RING NEEDLE ROLLER BEARINGS WITHOUT INNER RING

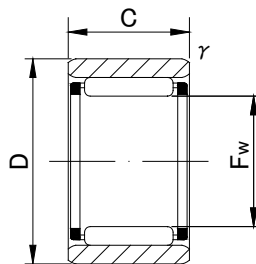
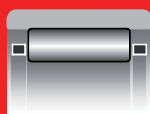

RNAF

RNAF(W)



RNAF(W) TYPE

Shaft Diameter (mm)	Designation	Dimensions (mm)				Standard mounting dimensions (mm)		
		Fw	D	C	r/s min	db	Da MAX	Db
20	RNAF202813	20	28	13	0.3	23.6	26	20.6
	RNAFW202826	20 +0.033	28	26	0.3	23.6	26	20.6
	RNAF203212	20 +0.020	32	12	0.3	25.4	30	20.6
	RNAFW203224	20	32	24	0.3	25.4	30	20.6
22	RNAF223013	22	30	13	0.3	25.6	28	22.6
	RNAFW223026	22 +0.033	30	26	0.3	25.6	28	22.6
	RNAF223516	22 +0.020	35	16	0.3	27.8	33	22.6
	RNAFW223532	22	35	32	0.3	27.8	33	22.6
25	RNAF253517	25	35	17	0.3	29.5	33	25.6
	RNAFW253526	25 +0.033	35	26	0.3	29.5	33	25.6
	RNAF253716	25 +0.020	37	16	0.3	30.4	35	25.6
	RNAFW253732	25	37	32	0.3	30.4	35	25.6
28	RNAF284016	28 +0.033	40	16	0.3	33.4	38	28.6
	RNAFW284032	28 +0.020	40	32	0.3	33.4	38	28.6
30	RNAF304017	30	40	17	0.3	34.5	38	30.6
	RNAFW304026	30 +0.033	40	26	0.3	34.5	38	30.6
	RNAF304216	30 +0.020	42	16	0.3	35.4	40	30.6
	RNAFW304232	30	42	32	0.3	35.4	40	30.6
35	RNAF354517	35	45	17	0.3	39.5	43	35.6
	RNAFW354526	35 +0.041	45	26	0.3	39.5	43	35.6
	RNAF354716	35 +0.025	47	16	0.3	40.4	45	35.6
	RNAFW354732	35	47	32	0.3	40.4	45	35.6
40	RNAF405017	40	50	17	0.3	43.5	48	40.8
	RNAFW405034	40 +0.041	50	34	0.3	43.5	48	40.8
	RNAF405520	40 +0.025	55	20	0.3	45.2	53	40.8
	RNAFW405540	40	55	40	0.3	45.2	53	40.8
45	RNAF455517	45	55	17	0.3	48.5	53	45.8
	RNAFW455534	45 +0.041	55	34	0.3	48.5	53	45.8
	RNAF456220	45 +0.025	62	20	0.3	50.9	60	45.8
	RNAFW456240	45	62	40	0.3	50.9	60	45.8
50	RNAF506220	50	62	20	0.3	54.2	60	50.8
	RNAFW506240	50 +0.041	62	40	0.3	54.2	60	50.8
	RNAF506520	50 +0.025	65	20	0.3	55.2	63	50.8
	RNAFW506540	50	65	40	0.6	55.2	61	50.8

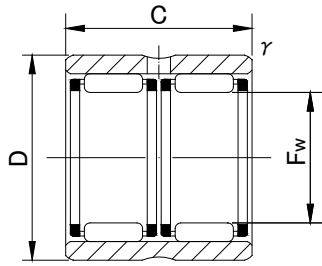

RNAFW

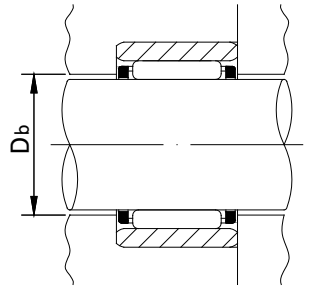
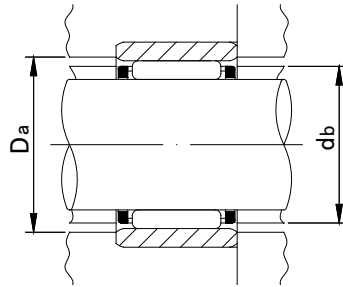

RNAFW(W)



Basic dynamic load rating	Basic static load rating	Limiting speed*	Mass	Usable bearing designation	
Cr N	Cor N	rpm	g (approx)	INNER RING	WITH INNER RING
9 600	13 500	20 000	25	IR152013	NAF152813
16 500	27 100	20 000	50	IR152026	NAFW152826
12 400	14 300	20 000	37	IR152012	NAF153212
21 200	28 600	20 000	75	—	—
10 200	15 200	18 000	27	IR172213	NAF173013
17 600	30 300	18 000	54	IR172226	NAFW173026
17 600	20 900	18 000	59	IR172216	NAF173516
30 200	41 900	18 000	117	IR172232	NAFW173532
17 300	26 600	16 000	51	IR202517	NAF203517
22 500	37 200	16 000	78	IR202526	NAFW203526
19 400	24 500	16 000	57	IR202516	NAF203716
33 200	49 000	16 000	114	IR202532	NAFW203732
20 100	26 500	14 000	63	—	—
34 400	53 000	14 000	125	—	—
18 600	31 100	13 000	59	IR253017	NAF254017
24 200	43 400	13 000	91	IR253026	NAFW254026
20 800	28 300	13 000	66	IR253016	NAF254216
35 700	56 800	13 000	132	IR253032	NAFW254232
20 500	36 900	11 000	68	IR303517	NAF304517
26 600	51 600	11 000	103	IR303526	NAFW304526
23 000	33 800	11 000	76	IR303516	NAF304716
39 500	67 800	11 000	151	IR303532	NAFW304732
22 200	42 700	10 000	75	IR354017	NAF355017
38 000	85 300	10 000	152	IR354034	NAFW355034
31 500	48 000	10 000	142	IR354020	NAF355520
53 900	96 000	10 000	280	IR354040	NAFW355540
23 200	47 200	10 000	84	IR404517	NAF405517
39 900	94 200	10 000	167	IR404534	NAFW405534
33 200	53 300	9 000	185	IR404520	NAF406220
57 000	106 900	9 000	370	IR404540	NAFW406240
27 100	59 300	8 000	139	IR455020	NAF456220
46 400	118 700	8 000	276	IR455040	NAFW456240
35 900	61 100	8 000	170	—	—
61 500	122 600	8 000	345	—	—

* Suitable for oil lubrication. In case of grease lubrication, down to 50% of this value.

MACHINED RING NEEDLE ROLLER BEARINGS WITHOUT INNER RING

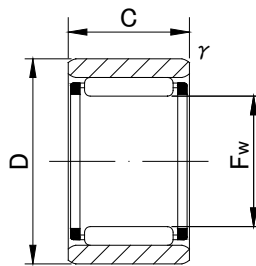
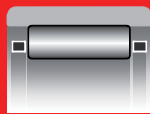

RNAF

RNAF(W)



RNAF(W) TYPE

Shaft Diameter (mm)	Designation	Dimensions (mm)				Standard mounting dimensions (mm)		
		Fw	D	C	r/s min	db	Da MAX	Db
55	RNAF556820	55	68	20	0.6	59.5	64	55.8
	RNAFW556840	55 +0.049	68	40	0.6	59.5	64	55.8
	RNAF557220	55 +0.030	72	20	0.6	60.9	68	55.8
	RNAFW557240	55	72	40	0.6	60.9	68	55.8
60	RNAF607820	60 +0.049	78	20	1	66.3	73	60.8
	RNAFW607840	60 +0.030	78	40	1	66.3	73	60.8
65	RNAF658530	65 +0.049	85	30	1	72	80	66
	RNAFW658560	65 +0.030	85	60	1	72	80	66
70	RNAF709030	70 +0.049	90	30	1	77	85	71
	RNAFW709060	70 +0.030	90	60	1	77	85	71
75	RNAF759530	75 +0.049	95	30	1	82	90	76
	RNAFW759560	75 +0.030	95	60	1	82	90	76
80	RNAF8010030	80 +0.049	100	30	1	87	95	81
	RNAFW8010060	80 +0.030	100	60	1	87	95	81
85	RNAF8510530	85 +0.058 +0.036	105	30	1	92	100	86
90	RNAF9011030	90 +0.058 +0.036	110	30	1	97	105	91
95	RNAF9511530	95 +0.058 +0.036	115	30	1	102	110	96
100	RNAF10012030	100 +0.058 +0.036	120	30	1	107	115	101

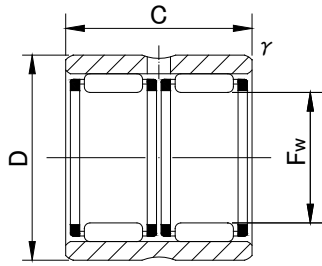

RNAFW

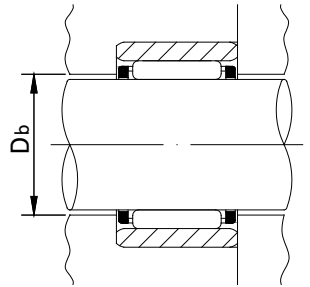
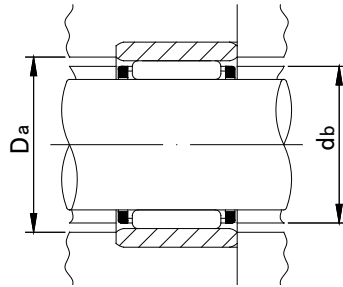

Basic dynamic load rating	Basic static load rating	Limiting speed*	Mass	Usable bearing designation	
Cr N	Cor N	rpm	g (approx)	INNER RING	WITH INNER RING
28 500	66 000	7 500	167	IR505520	NAF506820
48 900	132 400	7 500	330	IR505540	NAFW506840
37 400	66 400	7 500	215	IR455520	NAF457220
64 100	132 400	7 500	435	IR455540	NAFW457240
38 900	71 700	6 500	255	IR506020	NAF507820
66 700	143 200	6 500	510	IR506040	NAFW507840
59 300	127 500	6 000	465	IR556530	NAF558530
102 000	254 000	6 000	950	IR556560	NAFW558560
61 200	135 300	5 500	500	IR607030	NAF609030
104 900	271 600	5 500	1 000	IR607060	NAFW609060
63 200	144 200	5 500	530	IR657530	NAF659530
108 900	289 300	5 500	1 050	IR657560	NAFW659560
64 900	153 000	5 000	560	IR708030	NAF7010030
111 800	306 000	5 000	1 120	IR708060	NAFW7010060
66 600	160 800	4 800	590	IR758530	NAF7510530
69 500	173 600	4 500	620	IR809030	NAF8011030
70 900	182 400	4 200	650	IR859530	NAF8511530
72 600	191 200	4 000	690	IR9010030	NAF9012030

* Suitable for oil lubrication. In case of grease lubrication, down to 50% of this value.

MACHINED RING NEEDLE ROLLER BEARINGS WITH INNER RING

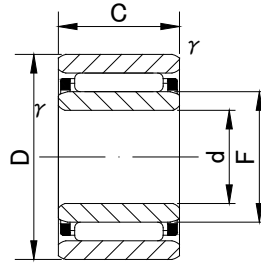
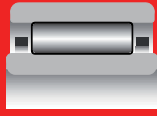

NAF

NAF(W)



NAF(W) TYPE

Shaft Diameter (mm)	Designation	Dimensions (mm)					Other Dimensions	
		d	D	C	r/s min	F	db	Da MAX
6	NAF 61710	6 ⁰ _{-0.008}	17	10	0.3	10	12.4	15
7	NAF 72012	7 ⁰ _{-0.008}	20	12	0.3	10	13.5	18
9	NAF 92212	9 ⁰ _{-0.008}	22	12	0.3	12	17.5	20
10	NAF 102213	10 ⁰ _{-0.008}	22	13	0.3	14	17.6	20
	NAFW 102220	10 ⁰ _{-0.008}	22	20	0.3	14	17.6	20
	NAF 102612	10 ⁰ _{-0.008}	26	12	0.3	14	19.4	24
12	NAF 122413	12 ⁰ _{-0.008}	24	13	0.3	16	19.6	22
	NAFW 122420	12 ⁰ _{-0.008}	24	20	0.3	16	19.6	22
	NAF 122812	12 ⁰ _{-0.008}	28	12	0.3	16	21.4	26
15	NAF 152813	15 ⁰ _{-0.008}	28	13	0.3	20	23.6	26
	NAFW 152826	15 ⁰ _{-0.008}	28	26	0.3	20	23.6	26
	NAF 153212	15 ⁰ _{-0.008}	32	12	0.3	20	25.4	30
17	NAF 173013	17 ⁰ _{-0.008}	30	13	0.3	22	25.6	28
	NAFW 173026	17 ⁰ _{-0.008}	30	26	0.3	22	25.6	28
	NAF 173516	17 ⁰ _{-0.008}	35	16	0.3	22	27.8	33
	NAFW 173532	17 ⁰ _{-0.008}	35	32	0.3	22	27.8	33
20	NAF 203517	20 ⁰ _{-0.010}	35	17	0.3	25	29.5	33
	NAFW 203526	20 ⁰ _{-0.010}	35	26	0.3	25	29.5	33
	NAF 203716	20 ⁰ _{-0.010}	37	16	0.3	25	30.4	35
	NAFW 203732	20 ⁰ _{-0.010}	37	32	0.3	25	30.4	35
25	NAF 254017	25 ⁰ _{-0.010}	40	17	0.3	30	34.5	38
	NAFW 254026	25 ⁰ _{-0.010}	40	26	0.3	30	34.5	38
	NAF 254216	25 ⁰ _{-0.010}	42	16	0.3	30	35.4	40
	NAFW 254232	25 ⁰ _{-0.010}	42	32	0.3	30	35.4	40
30	NAF 304517	30 ⁰ _{-0.010}	45	17	0.3	35	39.5	43
	NAFW 304526	30 ⁰ _{-0.010}	45	26	0.3	35	39.5	43
	NAF 304716	30 ⁰ _{-0.010}	47	16	0.3	35	40.4	45
	NAFW 304732	30 ⁰ _{-0.010}	47	32	0.3	35	40.4	45

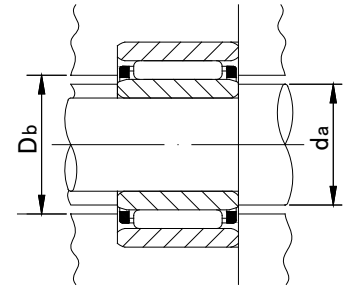
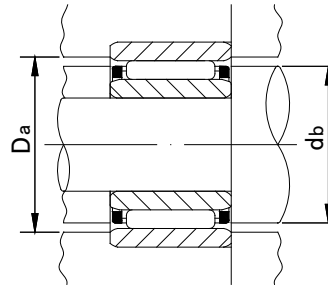
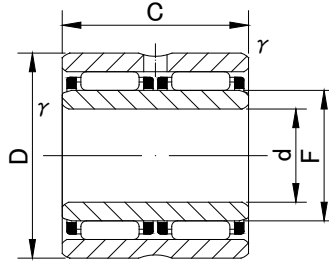

NAFW



Standard mounting dimensions (mm)		Basic dynamic load rating	Basic static load rating	Limiting speed*	Mass	Usable bearing designation		
da						Cr N	Cor N	rpm
MIN	MAX	Db						
8	9.7	10.4	4 100	4 500	28 000	14	RNAF101710	IR61010
9	9.7	10.4	6 000	6 000	28 000	23	RNAF102012	IR71012
11	11.5	12.4	9 000	8 400	26 000	24	RNAF122212	IR91212
12	13	14.6	7 800	9 400	24 000	26	RNAF142213	IR101413
12	13	14.6	10 800	14 200	24 000	40	RNAFW142220	IR101420
12	13	14.6	9 800	9 700	24 000	36	RNAF142612	IR101412
14	15	16.6	8 600	11 000	23 000	30	RNAF162413	IR121613
14	15	16.6	11 900	16 700	23 000	45	RNAFW162420	IR121620
14	15	16.6	10 500	10 900	23 000	40	RNAF162812	IR121612
17	19	20.6	9 600	13 500	20 000	37	RNAF202813	IR152013
17	19	20.6	16 500	27 100	20 000	76	RNAFW202826	IR152026
17	19	20.6	12 400	14 300	20 000	51	RNAF203212	IR152012
19	21	22.6	10 200	15 200	18 000	43	RNAF223013	IR172213
19	21	22.6	17 600	30 300	18 000	85	RNAFW223026	IR172226
19	21	22.6	17 600	20 900	18 000	77	RNAF223516	IR172216
19	21	22.6	30 200	41 900	18 000	155	RNAFW223532	IR172232
22	24	25.6	17 300	26 600	16 000	75	RNAF253517	IR202517
22	24	25.6	22 500	37 200	16 000	114	RNAFW253526	IR202526
22	24	25.6	19 400	24 500	16 000	80	RNAF253716	IR202516
22	24	25.6	33 200	49 000	16 000	158	RNAFW253732	IR202532
27	29	30.6	18 600	31 100	13 000	88	RNAF304017	IR253017
27	29	30.6	24 200	43 400	13 000	136	RNAFW304026	IR253026
27	29	30.6	20 800	28 300	13 000	94	RNAF304216	IR253016
27	29	30.6	35 700	56 800	13 000	187	RNAFW304232	IR253032
32	34	35.6	20 500	36 900	11 000	100	RNAF354517	IR303517
32	34	35.6	26 600	51 600	11 000	155	RNAFW354526	IR303526
32	34	35.6	23 000	33 800	11 000	108	RNAF354716	IR303516
32	34	35.6	39 500	67 800	11 000	215	RNAFW354732	IR303532

* Suitable for oil lubrication. In case of grease lubrication, down to 50% of this value.

MACHINED RING NEEDLE ROLLER BEARINGS WITH INNER RING

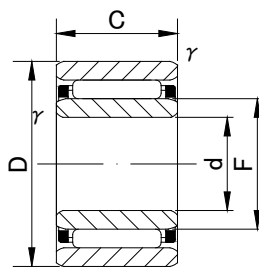
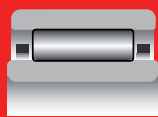

NAF

NAF(W)



NAF(W) TYPE

Shaft Diameter (mm)	Designation	Dimensions (mm)						
		d	D	C	r/s min	F	db	Da MAX
35	NAF 355017	35	50	17	0.3	40	43.5	48
	NAFW 355034	35 ₀	50	34	0.3	40	43.5	48
	NAF 355520	35 _{-0.012}	55	20	0.3	40	45.2	53
	NAFW 355540	35	55	40	0.3	40	45.2	53
40	NAF 405517	40	55	17	0.3	45	48.5	53
	NAFW 405534	40 ₀	55	34	0.3	45	48.5	53
	NAF 406220	40 _{-0.012}	62	20	0.3	45	50.9	60
	NAFW 406240	40	62	40	0.3	45	50.9	60
45	NAF 456220	45	62	20	0.3	50	54.2	60
	NAFW 456240	45 ₀	62	40	0.3	50	54.2	60
	NAF 457220	45 _{-0.012}	72	20	0.6	55	60.9	68
	NAFW 457240	45	72	40	0.6	55	60.9	68
50	NAF 506820	50	68	20	0.6	55	59.5	64
	NAFW 506840	50 ₀	68	40	0.6	55	59.5	64
	NAF 507820	50 _{-0.012}	78	20	1	60	66.3	73
	NAFW 507840	50	78	40	1	60	66.3	73
55	NAF 558530	55 ₀	85	30	1	65	72	80
	NAFW 558560	55 _{-0.015}	85	60	1	65	72	80
60	NAF 609030	60 ₀	90	30	1	70	77	85
	NAFW 609060	60 _{-0.015}	90	60	1	70	77	85
65	NAF 659530	65 ₀	95	30	1	75	82	90
	NAFW 659560	65 _{-0.015}	95	60	1	75	82	90
70	NAF 7010030	70 ₀	100	30	1	80	87	95
	NAFW 7010060	70 _{-0.015}	100	60	1	80	87	95
75	NAF 7510530	75 ₀ -0.015	105	30	1	85	92	100
80	NAF 8011030	80 ₀ -0.015	110	30	1	90	97	105
85	NAF 8511530	85 ₀ -0.020	115	30	1	95	102	110
90	NAF 9012030	90 ₀ -0.020	120	30	1	100	107	115

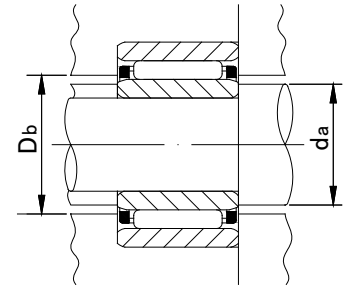
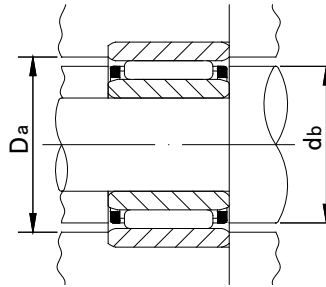
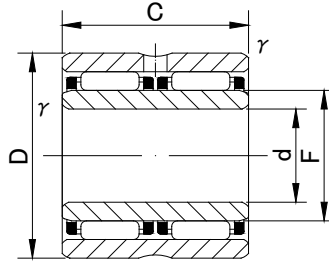

NAFW

NAF(W)



Standard mounting dimensions (mm)		Basic dynamic load rating	Basic static load rating	Limiting speed*	Mass	Usable bearing designation		
da		Db	Cr N	Cor N	rpm	g (approx)	OUTER RING	INNER RING
MIN	MAX							
37	39	40.8	22 200	42 700	10 000	115	RNAF405017	IR354017
37	39	40.8	38 000	85 300	10 000	230	RNAFW405034	IR354034
37	39	40.8	31 500	48 000	10 000	188	RNAF405520	IR354020
37	39	40.8	53 900	96 000	10 000	375	RNAFW405540	IR354040
42	44	45.8	23 200	47 200	10 000	129	RNAF455517	IR404517
42	44	45.8	39 900	94 200	10 000	255	RNAFW455534	IR404534
42	44	45.8	33 200	53 300	9 000	236	RNAF456220	IR404520
42	44	45.8	57 000	106 900	9 000	475	RNAFW456240	IR404540
47	49	50.8	27 100	59 300	8 000	197	RNAF506220	IR455020
49	49.5	50.8	46 400	118 700	8 000	389	RNAFW506240	IR455040
49	54	55.8	37 400	66 400	7 500	340	RNAF557220	IR455520
49	54	55.8	64 100	132 400	7 500	685	RNAFW557240	IR455540
54	54.5	55.8	28 500	66 000	7 500	230	RNAF556820	IR505520
54	54.5	55.8	48 900	132 400	7 500	465	RNAFW556840	IR505540
55	59	60.8	38 900	71 700	6 500	390	RNAF607820	IR506020
55	59	60.8	66 700	143 200	6 500	775	RNAFW607840	IR506040
60	63	66	59 300	127 500	6 000	680	RNAF658530	IR556530
60	63	66	102 000	254 000	6 000	1 380	RNAFW658560	IR556560
65	68	71	61 200	135 300	5 500	740	RNAF709030	IR607030
65	68	71	104 900	271 600	5 500	1 470	RNAFW709060	IR607060
70	73	76	63 200	144 200	5 500	800	RNAF759530	IR657530
70	73	76	108 900	289 300	5 500	1 570	RNAFW759560	IR657560
75	78	81	64 900	153 000	5 000	840	RNAF801003	IR708030
75	78	81	111 800	306 000	5 000	1 670	RNAFW8010060	IR708060
80	83	86	66 600	160 800	4 800	890	RNAF8510530	IR758530
85	88	91	69 500	173 600	4 500	930	RNAF9011030	IR809030
90	93	96	70 900	182 400	4 200	970	RNAF9511530	IR859530
95	98	101	72 600	191 200	4 000	1 040	RNAF10012030	IR9010030

* Suitable for oil lubrication. In case of grease lubrication, down to 50% of this value.

INNER RINGS

IR,IRZ

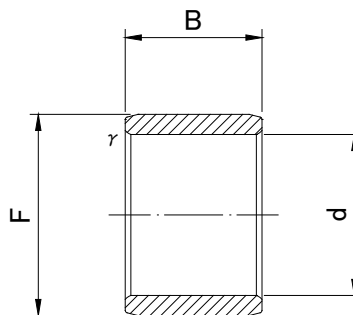

IR

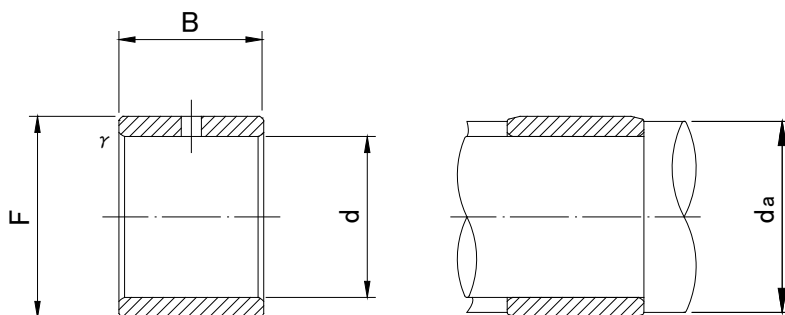

IR,IRZ TYPE

Shaft Diameter (mm)	Designation		Dimensions (mm)				Standard mounting dimensions (mm)	
						r/s min		
	IR	IRZ	d	F	B		MIN	MAX
5	IR 5812	—	5 ⁰	8	12	0.3	7	7.7
	IR 5816	—	5 ^{-0.008}	8	16	0.3	7	7.7
6	IR 6810	—	6 ⁰	8	10	0.15	7.2	7.7
	IR 6912	—	6 ⁰	9	12	0.3	8	8.7
	IR 6916	—	6 ^{-0.008}	9	16	0.3	8	8.7
	IR 61010	—	6	10	10	0.3	8	9.7
7	IR 7910	—	7	9	10	0.15	8.2	8.7
	IR 71010.5	—	7	10	10.5	0.3	9	9.7
	IR 71012	—	7 ⁰	10	12	0.3	9	9.7
	IR 71012.5	—	7 ^{-0.008}	10	12.5	0.3	9	9.7
	IR 71015.5	—	7	10	15.5	0.3	9	9.7
	IR 71016	—	7	10	16	0.3	9	9.7
8	IR 81011	—	8	10	11	0.15	9.2	9.7
	IR 81210	—	8	12	10	0.3	10	11
	IR 81210.5	—	8 ⁰	12	10.5	0.3	10	11
	IR 81212.5	—	8 ^{-0.008}	12	12.5	0.3	10	11
	IR 81215.5	—	8	12	15.5	0.3	10	11
9	IR 91211	—	9 ⁰	12	11	0.3	11	11.5
	IR 91212	—	9 ^{-0.008}	12	12	0.3	11	11.5
	IR 91216	—	9	12	16	0.3	11	11.5
10	IR 101312.5	—	10	13	12.5	0.3	12	12
	IR 101412	—	10	14	12	0.3	12	13
	IR 101412.5	—	10	14	12.5	0.3	12	13
	IR 101413	—	10	14	13	0.3	12	13
	—	IRZ 101414	10	14	14	0.3	12	13
	IR 101416	—	10	14	16	0.3	12	13
	IR 101416.5	—	10 ⁰	14	16.5	0.3	12	13
	IR 101420	—	10 ^{-0.008}	14	20	0.3	12	13
	IR 101420.5	—	10	14	20.5	0.3	12	13
	IR 101510.5	—	10	15	10.5	0.3	12	14
	IR 101515.5	—	10	15	15.5	0.3	12	14
	IR 101520.5	—	10	15	20.5	0.3	12	14
	IR 101525.5	—	10	15	25.5	0.3	12	14



IRZ



Mass	Usable bearing designation					
 g						
g (approx)	RNA 49	RNA 59	RNA 69	RNA 48	NK	RNAF
3	—	—	—	—	NK 8/12	—
4	—	—	—	—	NK 8/16	—
1.7	RNA 496	—	—	—	—	—
3.2	—	—	—	—	NK 9/12	—
4.3	—	—	—	—	NK 9/16	—
4	—	—	—	—	—	RNAF 101710
1.9	RNA 497	—	—	—	—	—
3.2	—	—	—	—	—	—
3.6	—	—	—	—	NK 10/12	RNAF 102012
3.9	—	—	—	—	—	—
4.8	—	—	—	—	—	—
5	—	—	—	—	NK 10/16	—
2.4	RNA 498	—	—	—	—	—
4.8	—	—	—	—	—	—
5.1	—	—	—	—	—	—
6	—	—	—	—	—	—
7.5	—	—	—	—	—	—
3.1	RNA 499	—	—	—	—	—
4.5	—	—	—	—	NK 12/12	RNAF 122212
6	—	—	—	—	NK 12/16	—
5.2	—	—	—	—	—	—
7	—	—	—	—	—	RNAF 142612
7.2	—	—	—	—	—	—
7.5	RNA 4900	—	—	—	—	RNAF 142213
8	RNA 4900UU	—	—	—	—	—
9	—	—	—	—	NK 14/16	—
9.6	—	—	—	—	—	—
11.5	—	—	—	—	NK 14/20	RNAFW 142220
11.9	—	—	—	—	—	—
7.9	—	—	—	—	—	—
11.7	—	—	—	—	—	—
15.5	—	—	—	—	—	—
19.3	—	—	—	—	—	—

INNER RINGS

IR,IRZ

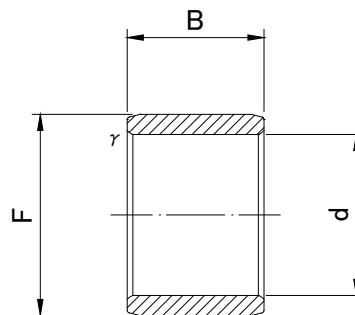

IR

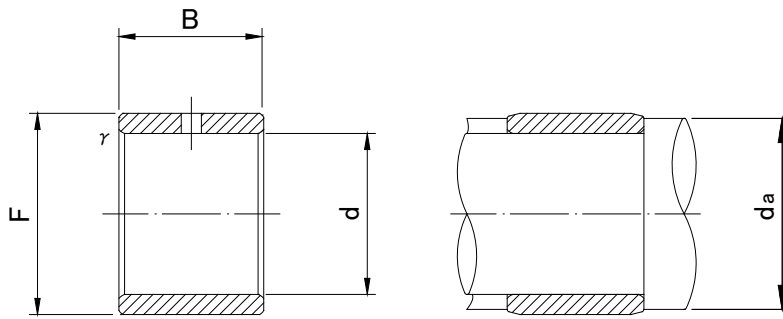

IR,IRZ TYPE

Shaft Diameter (mm)	Designation		Dimensions (mm)				Standard mounting dimensions (mm)		
						r/s min			
	IR	IRZ	d	F	B		MIN	MAX	
12	IR 121512.5	—	12	15	12.5	0.3	14	14	
	IR 121516	—	12	15	16	0.3	14	14	
	IR 121516.5	—	12	15	16.5	0.3	14	14	
	IR 121522.5	—	12	15	22.5	0.3	14	14	
	IR 121612	—	12	16	12	0.3	14	15	
	IR 121612.5	—	12	16	12.5	0.3	14	15	
	IR 121613	—	12	16	13	0.3	14	15	
	—	IRZ 121614	12	16	14	0.3	14	15	
	IR 121616	—	12 ⁰ _{-0.008}	16	16	16	0.3	14	15
	IR 121616.5	—	12	16	16.5	0.3	14	15	
	IR 121620	—	12	16	20	0.3	14	15	
	IR 121620.5	—	12	16	20.5	0.3	14	15	
	IR 121622	—	12	16	22	0.3	14	15	
	IR 121622.5	—	12	16	22.5	0.3	14	15	
	—	IRZ 121623	12	16	23	0.3	14	15	
	IR 121715.5	—	12	17	15.5	0.3	14	16	
IR 121720.5	—	12	17	20.5	0.3	14	16		
14	IR 141717	—	14 ⁰ _{-0.008}	17	17	0.3	16	16	
15	IR 151812.5	—	15	18	12.5	0.3	17	17	
	IR 151815.5	—	15	18	15.5	0.3	17	17	
	IR 151816.5	—	15	18	16.5	0.3	17	17	
	IR 151820.5	—	15	18	20.5	0.3	17	17	
	IR 151825.5	—	15	18	25.5	0.3	17	17	
	IR 151916	—	15	19	16	0.3	17	18	
	IR 151916.5	—	15	19	16.5	0.3	17	18	
	IR 151920	—	15	19	20	0.3	17	18	
	IR 151920.5	—	15 ⁰ _{-0.008}	19	20.5	0.3	17	18	
	IR 152012	—	15	20	12	0.3	17	19	
	IR 152013	—	15	20	13	0.3	17	19	
	—	IRZ 152014	15	20	14	0.3	17	19	
	IR 152015.5	—	15	20	15.5	0.3	17	19	
	IR 152018	—	15	20	18	0.3	17	19	
	IR 152020.5	—	15	20	20.5	0.3	17	19	
	IR 152023	—	15	20	23	0.3	17	19	
	—	IRZ 152024	15	20	24	0.3	17	19	
IR 152026	—	15	20	26	0.3	17	19		



IRZ



Mass	Usable bearing designation					
						
g (approx)	RNA 49	RNA 59	RNA 69	RNA 48	NK	RNAF
6.1	—	—	—	—	—	—
7.8	—	—	—	—	—	—
8.1	—	—	—	—	—	—
11	—	—	—	—	—	—
8	—	—	—	—	—	RNAF 162812
8.5	—	—	—	—	—	—
8.5	RNA 4901	—	—	—	—	RNAF 162413
9.6	RNA 4901UU	—	—	—	—	—
10.5	—	—	—	—	NK 16/16	—
11.2	—	—	—	—	—	—
13.5	—	—	—	—	NK 16/20	RNAFW 162420
13.9	—	—	—	—	—	—
14.5	—	—	RNA 6901	—	—	—
15.2	—	—	—	—	—	—
15.5	—	—	RNA 6901UU	—	—	—
13.6	—	—	—	—	—	—
18	—	—	—	—	—	—
9.5	—	—	—	—	—	—
7.5	—	—	—	—	—	—
9.3	—	—	—	—	—	—
9.9	—	—	—	—	—	—
12.3	—	—	—	—	—	—
15.2	—	—	—	—	—	—
12.5	—	—	—	—	NK 19/16	—
13.6	—	—	—	—	—	—
16	—	—	—	—	NK 19/20	—
12.3	—	—	—	—	—	—
12	—	—	—	—	—	RNAF 203212
13.5	RNA 4902	—	—	—	—	RNAF 202813
14.5	RNA 4902UU	—	—	—	—	—
16.4	—	—	—	—	—	—
19	—	RNA 5902	—	—	—	—
21.5	—	—	—	—	—	—
24	—	—	RNA 6902	—	—	—
25	—	—	RNA 6902UU	—	—	—
28	—	—	—	—	—	RNAFW 202826

INNER RINGS

IR,IRZ

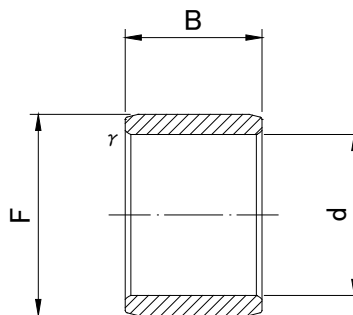

IR

IR,IRZ TYPE

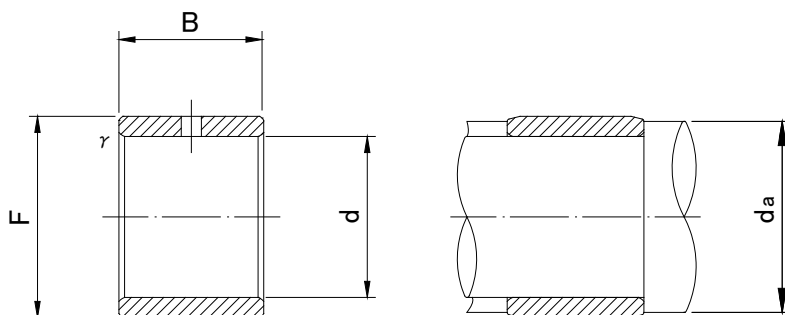

Shaft Diameter (mm)	Designation		Dimensions (mm)				Standard mounting dimensions (mm)		
						r/s min			
	IR	IRZ	d	F	B		MIN	MAX	
17	IR 172016.5	—	17	20	16.5	0.3	19	19	
	IR 172020	—	17	20	20	0.3	19	19	
	IR 172020.5	—	17	20	20.5	0.3	19	19	
	IR 172030.5	—	17	20	30.5	0.3	19	19	
	IR 172116	—	17	21	16	0.3	19	20	
	IR 172120	—	17	21	20	0.3	19	20	
	IR 172213	—	17	22	13	0.3	19	21	
	—	IRZ 172214	17	22	14	0.3	19	21	
	IR 172215.5	—	17	0 -0.008	22	15.5	0.3	19	21
	IR 172216	—	17		22	16	0.3	19	21
	IR 172216.5	—	17		22	16.5	0.3	19	21
	IR 172218	—	17		22	18	0.3	19	21
	IR 172223	—	17		22	23	0.3	19	21
	—	IRZ 172224	17		22	24	0.3	19	21
	IR 172225.5	—	17		22	25.5	0.3	19	21
	IR 172226	—	17		22	26	0.3	19	21
IR 172232	—	17	22		32	0.3	19	21	
20	IR 202416	—	20		24	16	0.3	22	23
	IR 202416.5	—	20		24	16.5	0.3	22	23
	IR 202420	—	20		24	20	0.3	22	23
	IR 202420.5	—	20		24	20.5	0.3	22	23
	IR 202510.5	—	20		25	10.5	0.3	22	24
	IR 202515.5	—	20		25	15.5	0.3	22	24
	IR 202516	—	20		25	16	0.3	22	24
	IR 202517	—	20	25	17	0.3	22	24	
	—	IRZ 202518	20	0 -0.010	25	18	0.3	22	24
	IR 202520	—	20		25	20	0.3	22	24
	IR 202520.5	—	20		25	20.5	0.3	22	24
	IR 202523	—	20		25	23	0.3	22	24
	IR 202525.5	—	20		25	25.5	0.3	22	24
	IR 202526	—	20		25	26	0.3	22	24
	IR 202526.5	—	20		25	26.5	0.3	22	24
	IR 202530	—	20		25	30	0.3	22	24
	—	IRZ 202531	20		25	31	0.3	22	24
	IR 202532	—	20		25	32	0.3	22	24



IRZ

IR,IRZ



Mass	Usable bearing designation					
						
g (approx)	RNA 49	RNA 59	RNA 69	RNA 48	NK	RNAF
11.1	—	—	—	—	—	—
14	—	—	—	—	—	—
13.7	—	—	—	—	—	—
20.5	—	—	—	—	—	—
14.5	—	—	—	—	NK 21/16	—
18	—	—	—	—	NK 21/20	—
15.5	RNA 4903	—	—	—	—	RNAF 223013
16.5	RNA 4903UU	—	—	—	—	—
18.3	—	—	—	—	—	—
19	—	—	—	—	—	RNAF 223516
19.4	—	—	—	—	—	—
21	—	RNA 5903	—	—	—	—
26.5	—	—	RNA 6903	—	—	—
28	—	—	RNA 6903UU	—	—	—
30	—	—	—	—	—	—
31	—	—	—	—	—	RNAFW 223026
38	—	—	—	—	—	RNAFW 223532
16.5	—	—	—	—	NK 24/16	—
17.5	—	—	—	—	—	—
20.5	—	—	—	—	NK 24/20	—
22	—	—	—	—	—	—
14.3	—	—	—	—	—	—
21	—	—	—	—	—	—
22	—	—	—	—	—	RNAF 253716
23	RNA 4904	—	—	—	—	RNAF 253517
24	RNA 4904UU	—	—	—	—	—
27	—	—	—	—	—	—
28	—	—	—	—	—	—
31	—	RNA 5904	—	—	—	—
34.5	—	—	—	—	—	—
36	—	—	—	—	—	RNAFW 253526
36	—	—	—	—	—	—
40.5	—	—	RNA 6904	—	—	—
41.5	—	—	RNA 6904UU	—	—	—
44	—	—	—	—	—	RNAFW 253732

INNER RINGS

IR,IRZ

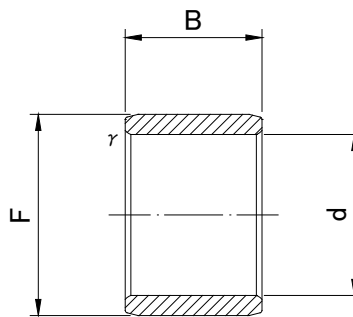

IR

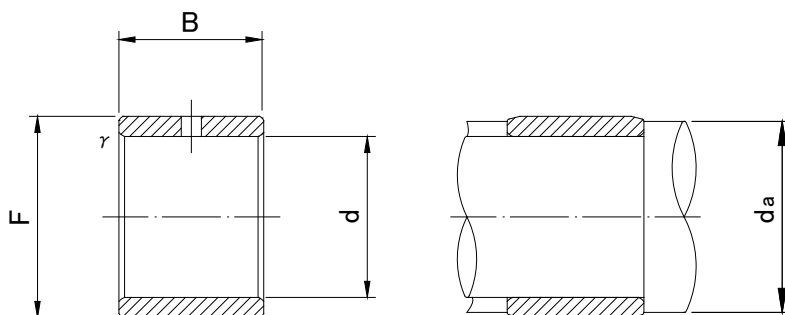

IR,IRZ TYPE

Shaft Diameter (mm)	Designation		Dimensions (mm)				Standard mounting dimensions (mm)	
						r/s min		
	IR	IRZ	d	F	B		MIN	MAX
22	IR 222616	—	22	26	16	0.3	24	25
	IR 222620	—	22	26	20	0.3	24	25
	IR 222817	—	22 ₀	28	17	0.3	24	27
	IR 222820.5	—	22 ^{-0.010}	28	20.5	0.3	24	27
	IR 222823	—	22	28	23	0.3	24	27
	IR 222830	—	22	28	30	0.3	24	27
25	IR 252920	—	25	29	20	0.3	27	28
	IR 252930	—	25	29	30	0.3	27	28
	IR 253015	—	25	30	15	0.3	24	29
	IR 253015.5	—	25	30	15.5	0.3	24	29
	IR 253016	—	25	30	16	0.3	27	29
	IR 253017	—	25	30	17	0.3	27	29
	—	IRZ 253018	25	30	18	0.3	27	29
	IR 253020	—	25	30	20	0.3	24	29
	IR 253020.5	—	25 ₀	30	20.5	0.3	24	29
	IR 253023	—	25 ^{-0.010}	30	23	0.3	27	29
	IR 253025.5	—	25	30	25.5	0.3	24	29
	IR 253026	—	25	30	26	0.3	27	29
	IR 253026.5	—	25	30	26.5	0.3	24	29
	IR 253030	—	25	30	30	0.3	27	29
	IR 253030.5	—	25	30	30.5	0.3	24	29
	—	IRZ 253031	25	30	31	0.3	27	29
	IR 253032	—	25	30	32	0.3	27	29
	IR 253038.5	—	25	30	38.5	0.3	24	29
28	IR 283217	—	28	32	17	0.3	30	31
	IR 283220	—	28	32	20	0.3	30	31
	IR 283220.5	—	28 ₀	32	20.5	0.3	30	31
	IR 283223	—	28 ^{-0.010}	32	23	0.3	30	31
	IR 283230	—	28	32	30	0.3	30	31
	IR 283230.5	—	28	32	30.5	0.3	30	31



IRZ



Mass	Usable bearing designation					
						
g (approx)	RNA 49	RNA 59	RNA 69	RNA 48	NK	RNAF
17.5	—	—	—	—	NK 26/16	—
24	—	—	—	—	NK 26/20	—
30.5	RNA 49/22	—	—	—	—	—
37	—	—	—	—	—	—
42	—	RNA 59/22	—	—	—	—
55	—	—	RNA 69/22	—	—	—
25	—	—	—	—	NK 29/20	—
38	—	—	—	—	NK 29/30	—
24.5	—	—	—	—	—	—
25.5	—	—	—	—	—	—
28	—	—	—	—	—	RNAF 304216
28.5	RNA 4905	—	—	—	—	RNAF 304017
29.5	RNA 4905UU	—	—	—	—	—
33	—	—	—	—	—	—
34	—	—	—	—	—	—
38	—	RNA 5905	—	—	—	—
42.5	—	—	—	—	—	—
44.5	—	—	—	—	—	RNAFW 304026
44	—	—	—	—	—	—
49	—	—	RNA 6905	—	—	—
50.5	—	—	—	—	—	—
51	—	—	RNA 6905UU	—	—	—
54	—	—	—	—	—	RNAFW 304232
64	—	—	—	—	—	—
24.5	RNA 49/28	—	—	—	—	—
28.5	—	—	—	—	NK 32/20	—
29.5	—	—	—	—	—	—
34	—	RNA 59/28	—	—	—	—
43	—	—	RNA 69/28	—	NK 32/30	—
44	—	—	—	—	—	—

INNER RINGS

IR,IRZ

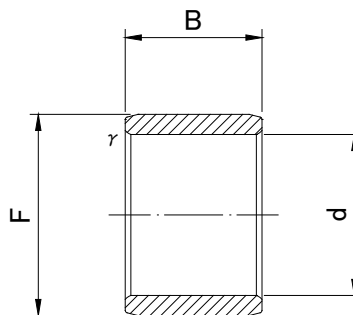

IR

IR,IRZ TYPE

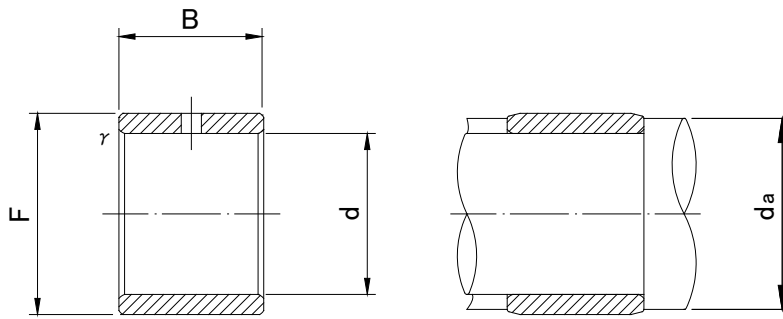

Shaft Diameter (mm)	Designation		Dimensions (mm)				Standard mounting dimensions (mm)	
						r/s min		
	IR	IRZ	d	F	B		MIN	MAX
30	IR 303516	—	30	35	16	0.3	32	34
	IR 303517	—	30	35	17	0.3	32	34
	—	IRZ 303518	30	35	18	0.3	32	34
	IR 303520	—	30	35	20	0.3	32	34
	IR 303520.5	—	30	35	20.5	0.3	34	34
	IR 303523	—	30	35	23	0.3	32	34
	IR 303525.5	—	30 ⁰ _{-0.010}	35	25.5	0.3	34	34
	IR 303526	—	30	35	26	0.3	32	34
	IR 303530	—	30	35	30	0.3	32	34
	IR 303530.5	—	30	35	30.5	0.3	34	34
	—	IRZ 303531	30	35	31	0.3	32	34
	IR 303532	—	30	35	32	0.3	32	34
	IR 303820	—	30	38	20	0.6	34	37
32	IR 323720	—	32	37	20	0.3	34	36
	IR 323730	—	32	37	30	0.3	34	36
	IR 324020	—	32 ⁰ _{-0.012}	40	20	0.6	36	39
	IR 324027	—	32	40	27	0.6	36	39
	IR 324036	—	32	40	36	0.6	36	39
35	IR 354017	—	35	40	17	0.3	37	39
	IR 354020	—	35	40	20	0.3	37	39
	IR 354020.5	—	35	40	20.5	0.3	39	39
	IR 354025.5	—	35	40	25.5	0.3	39	39
	IR 354030	—	35	40	30	0.3	37	39
	IR 354034	—	35 ⁰ _{-0.012}	40	34	0.3	37	39
	IR 354040	—	35	40	40	0.3	37	39
	IR 354220	—	35	42	20	0.6	39	41
	—	IRZ 354221	35	42	21	0.6	39	41
	IR 354227	—	35	42	27	0.6	39	41
	IR 354236	—	35	42	36	0.6	39	41
—	IRZ 354237	35	42	37	0.6	39	41	
38	IR 384320	—	38 ⁰ _{-0.012}	43	20	0.3	40	42
	IR 384330	—	38	43	30	0.3	40	42



IRZ

IR, IRZ



Mass	Usable bearing designation					
						
g (approx)	RNA 49	RNA 59	RNA 69	RNA 48	NK	RNAF
31.5	—	—	—	—	—	RNAF 354716
33.5	RNA 4906	—	—	—	—	RNAF 354517
35	RNA 4906UU	—	—	—	—	—
38.5	—	—	—	—	NK 35/20	—
40	—	—	—	—	—	—
44	—	RNA 5906	—	—	—	—
51	—	—	—	—	—	—
52	—	—	—	—	—	RNAFW 354526
59	—	—	RNA 6906	—	NK 35/30	—
60	—	—	—	—	—	—
61	—	—	RNA 6906UU	—	—	—
64	—	—	—	—	—	RNAFW 354732
65	—	—	—	—	—	—
43.5	—	—	—	—	NK 37/20	—
63	—	—	—	—	NK 37/30	—
69	RNA 49/32	—	—	—	—	—
92	—	RNA 59/32	—	—	—	—
123	—	—	RNA 69/32	—	—	—
39	—	—	—	—	—	RNAF 405017
46	—	—	—	—	NK 40/20	RNAF 405520
46.5	—	—	—	—	—	—
46	—	—	—	—	—	—
67	—	—	—	—	NK 40/30	—
78	—	—	—	—	—	RNAFW 405034
95	—	—	—	—	—	RNAFW 405540
65	RNA 4907	—	—	—	—	—
67	RNA 4907UU	—	—	—	—	—
80	—	RNA 5907	—	—	—	—
120	—	—	RNA 6907	—	—	—
120	—	—	RNA 6907UU	—	—	—
49.5	—	—	—	—	NK 43/20	—
72	—	—	—	—	NK 43/30	—

INNER RINGS

IR,IRZ

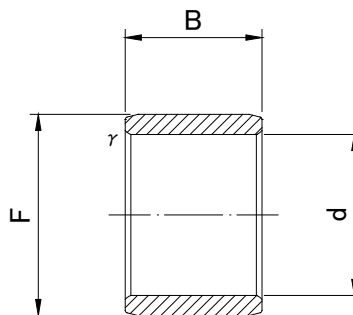

IR

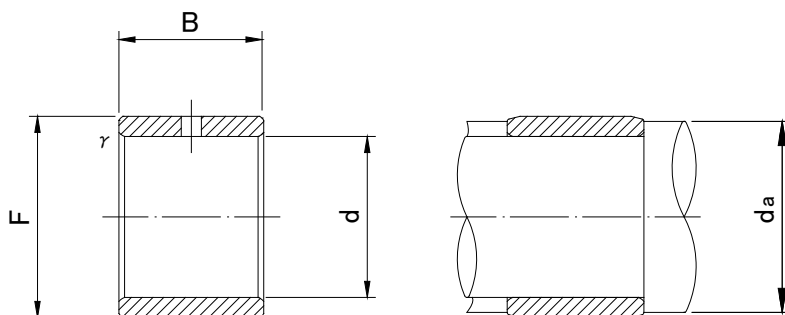

IR,IRZ TYPE

Shaft Diameter (mm)	Designation		Dimensions (mm)				Standard mounting dimensions (mm)		
						r/s min			
	IR	IRZ	d	F	B		MIN	MAX	
40	IR 404517	—	40	45	17	0.3	42	44	
	IR 404520	—	40	45	20	0.3	42	44	
	IR 404520.5	—	40	45	20.5	0.6	44	44	
	IR 404525.5	—	40	45	25.5	0.6	44	44	
	IR 404530	—	40	45	30	0.3	42	44	
	IR 404530.5	—	40	45	30.5	0.6	44	44	
	IR 404534	—	40	45	34	0.3	42	44	
	IR 404540	—	40 ⁰ _{-0.012}	45	40	40	0.3	42	44
	IR 404540.5	—	40	45	40.5	40.5	0.6	44	44
	IR 404822	—	40	48	22	22	0.6	44	47
	—	IRZ 404823	40	48	23	23	0.6	44	47
	IR 404830	—	40	48	30	30	0.6	44	47
	IR 404840	—	40	48	40	40	0.6	44	47
—	IRZ 404841	40	48	41	41	0.6	44	47	
42	IR 424720	—	42 ⁰ _{-0.012}	47	20	20	0.3	44	46
	IR 424730	—	42	47	30	30	0.3	44	46
45	IR 455020	—	45	50	20	20	0.3	47	49
	IR 455025	—	45	50	25	25	0.6	49	49.5
	IR 455025.5	—	45	50	25.5	25.5	0.6	44	49
	IR 455030.5	—	45	50	30.5	30.5	0.6	44	49
	IR 455035	—	45	50	35	35	0.6	49	49.5
	IR 455040	—	45	50	40	40	0.3	49	49.5
	IR 455222	—	45 ⁰ _{-0.012}	52	22	22	0.6	49	51
	—	IRZ 455223	45	52	23	23	0.6	49	51
	IR 455230	—	45	52	30	30	0.6	49	51
	IR 455240	—	45	52	40	40	0.6	49	51
	—	IRZ 455241	45	52	41	41	0.6	49	51
	IR 455520	—	45	55	20	20	0.6	49	54
IR 455522	—	45	55	22	22	1	50	54	
IR 455540	—	45	55	40	40	0.6	49	54	



IRZ



Mass	Usable bearing designation					
						
g (approx)	RNA 49	RNA 59	RNA 69	RNA 48	NK	RNAF
44.5	—	—	—	—	—	RNAF 45517
51	—	—	—	—	NK 45/20	RNAF 456220
52.5	—	—	—	—	—	—
65.5	—	—	—	—	—	—
77	—	—	—	—	NK 45/30	—
78.5	—	—	—	—	—	—
88	—	—	—	—	—	RNAFW 45534
105	—	—	—	—	—	RNAFW 456240
104	—	—	—	—	—	—
93	RNA 4908	—	—	—	—	—
95	RNA 4908UU	—	—	—	—	—
123	—	RNA 5908	—	—	—	—
165	—	—	RNA 6908	—	—	—
170	—	—	RNA 6908UU	—	—	—
54	—	—	—	—	NK 47/20	—
81	—	—	—	—	NK 47/30	—
58	—	—	—	—	—	RNAF 506220
71	—	—	—	—	NK 50/25	—
73	—	—	—	—	—	—
87.5	—	—	—	—	—	—
95	—	—	—	—	NK 50/35	—
115	—	—	—	—	—	RNAFW 506240
88	RNA 4909	—	—	—	—	—
93	RNA 4909UU	—	—	—	—	—
123	—	RNA 5909	—	—	—	—
165	—	—	RNA 6909	—	—	—
170	—	—	RNA 6909UU	—	—	—
120	—	—	—	—	—	RNAF 557220
130	—	—	—	—	—	—
245	—	—	—	—	—	RNAFW 557240

INNER RINGS

IR,IRZ

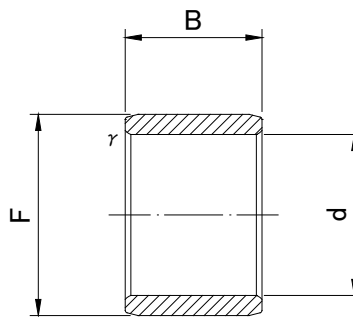

IR

IR,IRZ TYPE

Shaft Diameter (mm)	Designation		Dimensions (mm)				Standard mounting dimensions (mm)	
						r/s min		
	IR	IRZ	d	F	B		MIN	MAX
50	IR 505520	—	50	55	20	0.6	54	54.5
	IR 505525	—	50	55	25	0.6	54	54.5
	IR 505535	—	50	55	35	0.6	54	54.5
	IR 505540	—	50	55	40	0.6	54	54.5
	IR 505822	—	50	58	22	0.6	54	57
	—	IRZ 505823	50 ⁰	58	23	0.6	54	57
	IR 505830	—	50 ^{-0.012}	58	30	0.6	54	57
	IR 505840	—	50	58	40	0.6	54	57
	—	IRZ 505841	50	58	41	0.6	54	57
	IR 506020	—	50	60	20	1	55	59
	IR 506025	—	50	60	25	1	55	59
IR 506040	—	50	60	40	1	55	59	
55	IR 556025	—	55	60	25	0.6	59	59.5
	IR 556035	—	55	60	35	0.6	59	59.5
	IR 556325	—	55	63	25	1	60	61
	IR 556334	—	55 ⁰	63	34	1	60	61
	IR 556345	—	55 ^{-0.015}	63	45	1	60	61
	IR 556530	—	55	65	30	1	60	63
	IR 556560	—	55	65	60	1	60	63
60	IR 606825	—	60	68	25	0.6	64	66
	IR 606834	—	60	68	34	1	65	66
	IR 606835	—	60	68	35	0.6	64	66
	IR 606845	—	60 ⁰	68	45	1	65	66
	IR 607025	—	60 ^{-0.015}	70	25	1	65	68
	IR 607030	—	60	70	30	1	65	68
	IR 607060	—	60	70	60	1	65	68
65	IR 657225	—	65	72	25	1	70	70.5
	IR 657234	—	65	72	34	1	70	70.5
	IR 657245	—	65 ⁰	72	45	1	70	70.5
	IR 657335	—	65 ^{-0.015}	73	35	0.6	69	71
	IR 657530	—	65	75	30	1	70	73
	IR 657560	—	65	75	60	1	70	73

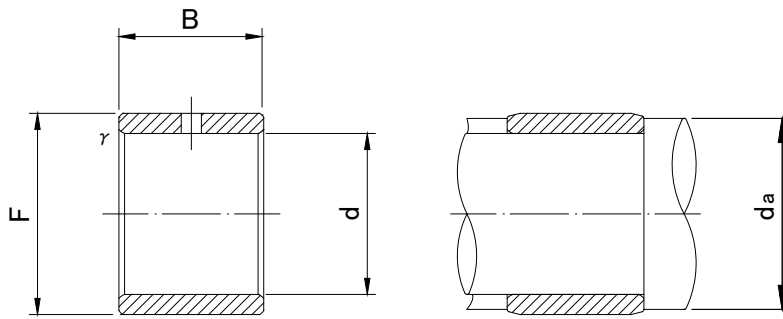

IRZ

IR,IRZ



Mass	Usable bearing designation					
 g						
g (approx)	RNA 49	RNA 59	RNA 69	RNA 48	NK	RNAF
63	—	—	—	—	—	RNAF 556820
77	—	—	—	—	NK 55/25	—
110	—	—	—	—	NK 55/35	—
130	—	—	—	—	—	RNAFW 556840
116	RNA 4910	—	—	—	—	—
118	RNA 4910UU	—	—	—	—	—
159	—	RNA 5910	—	—	—	—
210	—	—	RNA 6910	—	—	—
215	—	—	RNA 6910UU	—	—	—
135	—	—	—	—	—	RNAF 607820
163	—	—	—	—	—	—
265	—	—	—	—	—	RNAFW 607840
88	—	—	—	—	NK 60/25	—
120	—	—	—	—	NK 60/35	—
145	RNA 4911	—	—	—	—	—
192	—	RNA 5911	—	—	—	—
255	—	—	RNA 6911	—	—	—
220	—	—	—	—	—	RNAF 658530
435	—	—	—	—	—	RNAFW 658560
150	RNA 4912	—	—	—	NK 68/25	—
206	—	RNA 5912	—	—	—	—
210	—	—	—	—	NK 68/35	—
275	—	—	RNA 6912	—	—	—
195	—	—	—	—	—	—
240	—	—	—	—	—	RNAF 709030
480	—	—	—	—	—	RNAFW 709060
145	RNA 4913	—	—	—	—	—
193	—	RNA 5913	—	—	—	—
255	—	—	RNA 6913	—	—	—
235	—	—	—	—	NK 73/35	—
260	—	—	—	—	—	RNAF 759530
520	—	—	—	—	—	RNAFW 759560

INNER RINGS

IR,IRZ

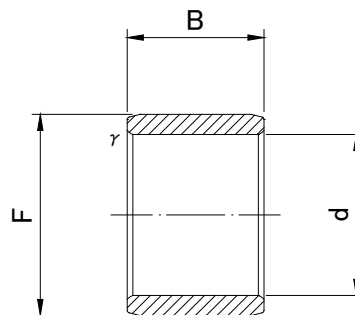

IR

IR,IRZ TYPE

Shaft Diameter (mm)	Designation		Dimensions (mm)				Standard mounting dimensions (mm)	
						r/s min		
	IR	IRZ	d	F	B		MIN	MAX
70	IR 708025	—	70	80	25	1	75	78
	IR 708030	—	70	80	30	1	75	78
	IR 708035	—	70 ₀	80	35	1	75	78
	IR 708040	—	70 ^{-0.015}	80	40	1	75	78
	IR 708054	—	70	80	54	1	75	78
	IR 708060	—	70	80	60	1	75	78
75	IR 758525	—	75	85	25	1	80	83
	IR 758530	—	75	85	30	1	80	83
	IR 758535	—	75 ₀	85	35	1	80	83
	IR 758540	—	75 ^{-0.015}	85	40	1	80	83
	IR 758554	—	75	85	54	1	80	83
80	IR 809025	—	80	90	25	1	85	88
	IR 809030	—	80	90	30	1	85	88
	IR 809035	—	80 ₀	90	35	1	85	88
	IR 809040	—	80 ^{-0.015}	90	40	1	85	88
	IR 809054	—	80	90	54	1	85	88
85	IR 859526	—	85	95	26	1	90	93
	IR 859530	—	85	95	30	1	90	93
	IR 859536	—	85 ₀	95	36	1	90	93
	IR 8510035	—	85 ^{-0.020}	100	35	1.1	91.5	98
	IR 8510046	—	85	100	46	1.1	91.5	98
	IR 8510063	—	85	100	63	1.1	91.5	98
90	IR 9010026	—	90	100	26	1	95	98
	IR 9010030	—	90	100	30	1	95	98
	IR 9010036	—	90 ₀	100	36	1	95	98
	IR 9010535	—	90 ^{-0.020}	105	35	1.1	96.5	103
	IR 9010546	—	90	105	46	1.1	96.5	103
	IR 9010563	—	90	105	63	1.1	96.5	103
95	IR 9510526	—	95	105	26	1	100	103
	IR 9510536	—	95	105	36	1	100	103
	IR 9511035	—	95 ₀	110	35	1.1	101.5	108
	IR 9511046	—	95 ^{-0.020}	110	46	1.1	101.5	108
	IR 9511063	—	95	110	63	1.1	101.5	108
100	IR 10011030	—	100	110	30	1.1	106.5	108
	IR 10011040	—	100 ₀	110	40	1.1	106.5	108
	IR 10011540	—	100 ^{-0.020}	115	40	1.1	106.5	113

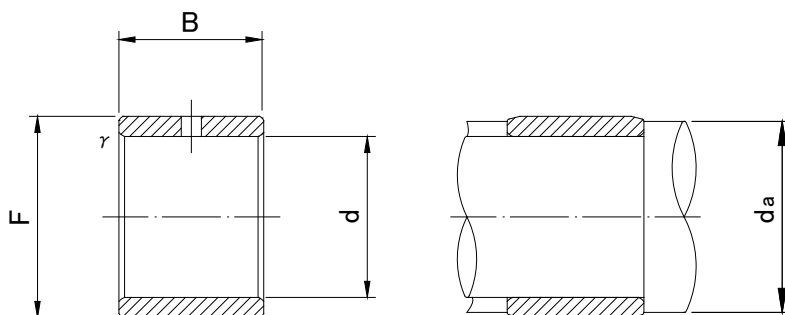

IRZ



Mass	Usable bearing designation					
						
g (approx)	RNA 49	RNA 59	RNA 69	RNA 48	NK	RNAF
225	—	—	—	—	NK 80/25	—
275	RNA 4914	—	—	—	—	RNAF 8010030
310	—	—	—	—	NK 80/35	—
358	—	RNA 5914	—	—	—	—
490	—	—	RNA 6914	—	—	—
560	—	—	—	—	—	RNAFW 8010060
240	—	—	—	—	NK 85/25	—
290	RNA 4915	—	—	—	—	RNAF 8510530
335	—	—	—	—	NK 85/35	—
385	—	RNA 5915	—	—	—	—
520	—	—	RNA 6915	—	—	—
255	—	—	—	—	NK 90/25	—
310	RNA 4916	—	—	—	—	RNAF 9011030
355	—	—	—	—	NK 90/35	—
408	—	RNA 5916	—	—	—	—
550	—	—	RNA 6916	—	—	—
280	—	—	—	—	NK 95/26	—
330	—	—	—	—	—	RNAF 9511530
390	—	—	—	—	NK 95/36	—
575	RNA 4917	—	—	—	—	—
760	—	RNA 5917	—	—	—	—
1 040	—	—	RNA 6917	—	—	—
295	—	—	—	—	NK 100/26	—
355	—	—	—	—	—	RNAF 10012030
415	—	—	—	—	NK 100/36	—
610	RNA 4918	—	—	—	—	—
800	—	RNA 5918	—	—	—	—
1 100	—	—	RNA 6918	—	—	—
315	—	—	—	—	NK 105/26	—
430	—	—	—	—	NK 105/36	—
650	RNA 4919	—	—	—	—	—
850	—	RNA 5919	—	—	—	—
1 160	—	—	RNA 6919	—	—	—
380	—	—	—	—	NK 110/30	—
500	—	—	—	—	NK 110/40	—
700	RNA 4920	—	—	—	—	—

INNER RINGS

IR,IRZ

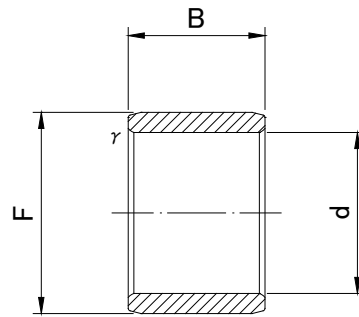

IR

IR,IRZ TYPE

Shaft Diameter (mm)	Designation		Dimensions (mm)				Standard mounting dimensions (mm)	
						r/s min		
	IR	IRZ	d	F	B		MIN	MAX
110	IR 11012030	—	110 ⁰	120	30	1.0	115	118
	IR 11012540	—	110 ^{-0.020}	125	40	1.1	116.5	123
120	IR 12013030	—	120 ⁰	130	30	1.0	125	128
	IR 12013545	—	120 ^{-0.020}	135	45	1.1	126.5	133
130	IR 13014535	—	130 ⁰	145	35	1.1	136.5	143
	IR 13015050	—	130 ^{-0.025}	150	50	1.5	138	148
140	IR 14015535	—	140 ⁰	155	35	1.1	146.5	153
	IR 14016050	—	140 ^{-0.025}	160	50	1.5	148	158
150	IR 15016540	—	150 ⁰ -0.025	165	40	1.1	156.5	163
160	IR 16017540	—	160 ⁰ -0.025	175	40	1.1	166.5	173

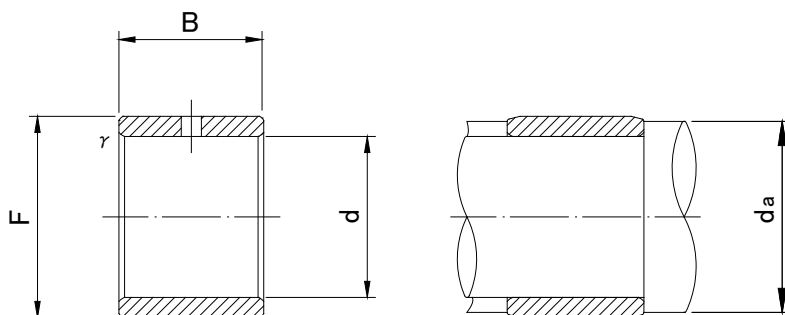

IRZ



Mass	Usable bearing designation					
g (approx)	RNA 49	RNA 59	RNA 69	RNA 48	NK	RNAF
410 840	— RNA 4922	— —	— —	RNA 4822 —	— —	— —
450 1 030	— RNA 4924	— —	— —	RNA 4824 —	— —	— —
860 1 670	— RNA 4926	— —	— —	RNA 4826 —	— —	— —
930 1 790	— RNA 4928	— —	— —	RNA 4828 —	— —	— —
1 130	—	—	—	RNA 4830	—	—
1 200	—	—	—	RNA 4832	—	—

CAM FOLLOWERS



Cam follower with pre-installed grease nipple

CF..AB

Standard type

CF..MAB

Stainless type

CFH..AB

Eccentric type

CFH..MAB

Eccentric stainless type

Ready use instantly after unpack the box thanks to pre-installed grease nipple.

•Conventional type: Need to fit a nipple

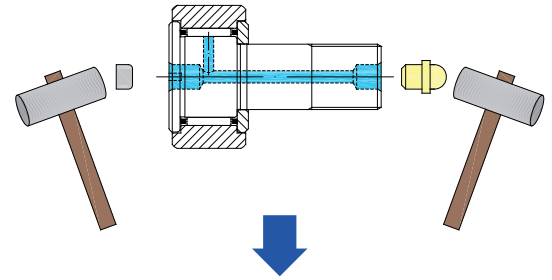

•Grease nipple fitted

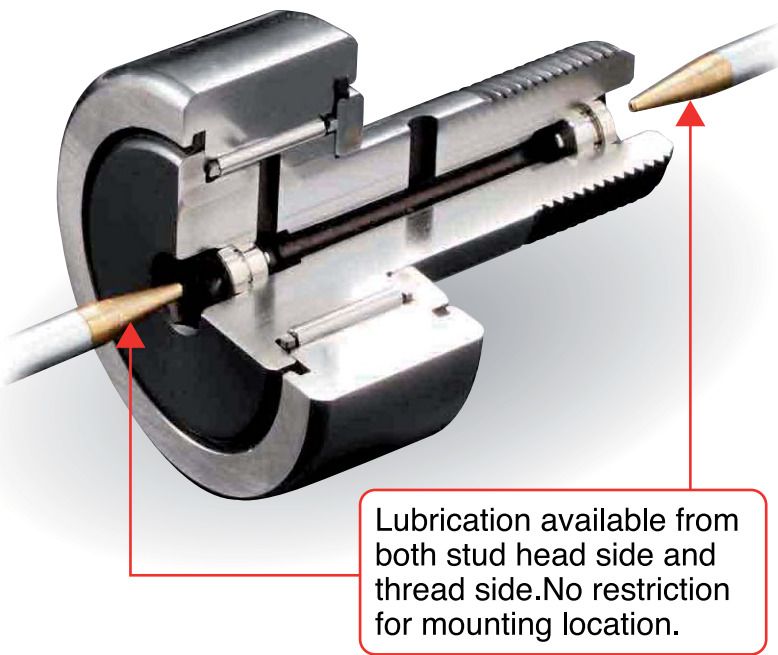
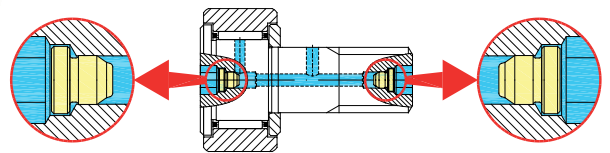

Lubrication available from both stud head side and thread side.No restriction for mounting location.

No restriction for mounting location thanks to hexagon socket shape in stud head and thread side.Easy mounting and removal is available thanks to having hexagon socket shape in both side.

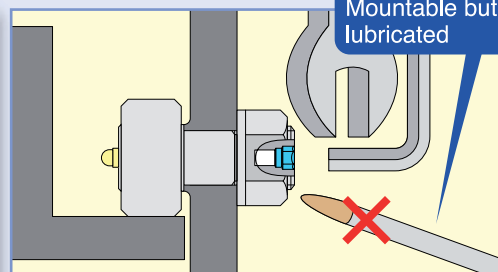

Conventional type (CF..B): Mountable but cannot be lubricated

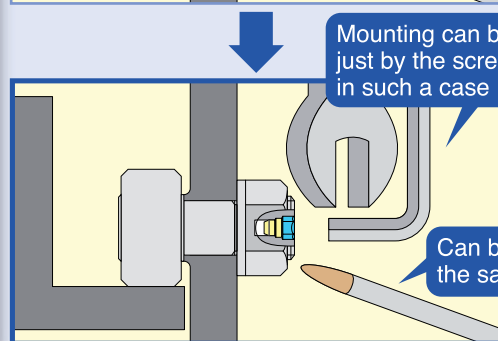

Mounting can be completed just by the screw side only in such a case

Can be greased in the same direction

Newly available versatile cam follower which has conquered disadvantages in traditional products!!

NUCF..AB Double-row cylindrical roller type

stud diameter
16 to 30mm

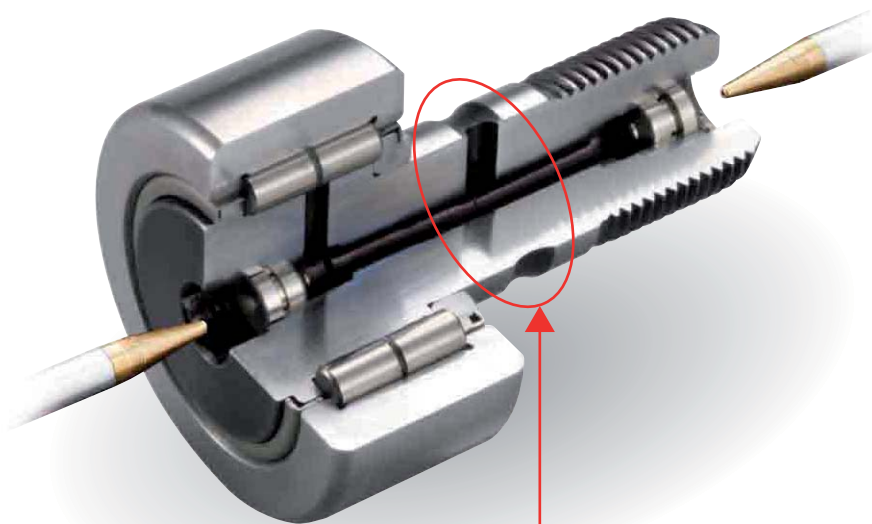

Lubrication area at the side of stud has an oil groove to eliminate bothersome groove machining process in the mounting side(NUCF type).

•Need to machine an internal oil groove

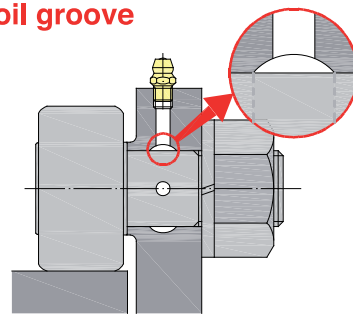

•Lubrication enabled only by vertical hole

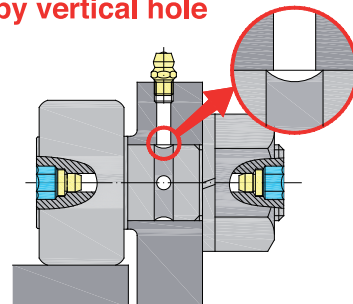

No restriction for mounting location thanks to hexagon socket shape in stud head and thread side. Easy mounting and removal is available thanks to having hexagon socket shape in both side.

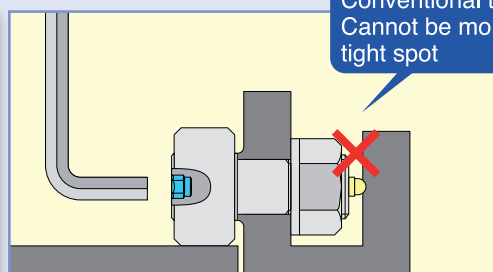

Conventional type (CF..A):
Cannot be mounted in a tight spot

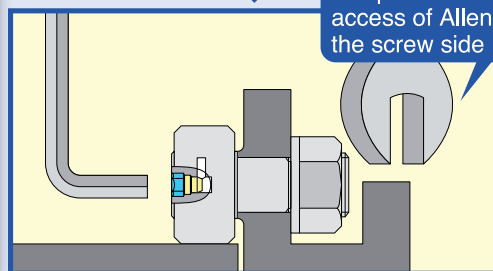

Installation can be completed even without any access of Allen wrench to the screw side

Type and Part Code

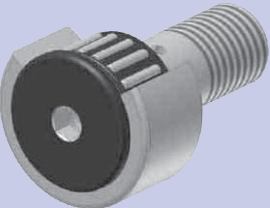
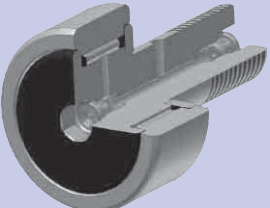
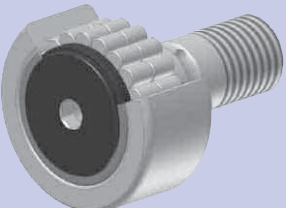
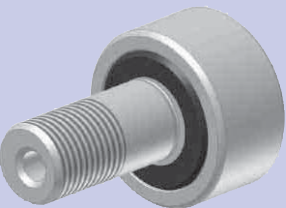
Type	Applicable axis diameter	Feature
 <p>CF</p>	$\phi 5 \sim \phi 30$	<p>General purpose cam follower with screwdriver groove on the stud head.</p> <p>Available with stainless steel type (code M) for higher durability.</p>
 <p>CF-A Hexagon hole</p>	$\phi 3 \sim \phi 30$	<p>Hexagon sockets at the head of stud.</p> <p>Easy mounting with hex-wrench.</p> <p>Available with hexagon sockets at thread side model(CF-B). (Applicable for shaft diameter 12 or more)</p> <p>Available with stainless steel type (code M) for higher corrosive resistance.</p>
 <p>CF-AB</p>	$\phi 10 \sim \phi 30$	<p>Both of stud head and thread ends have hexagon holes and integrated concave grease nipples. Available for mounting with either hexagon sockets and lubrication from both sides.</p> <p>Available with stainless steel type (code M) for higher corrosive resistance.</p>
 <p>NUCF-AB Double cylindrical roller</p>	$\phi 16 \sim \phi 30$	<p>Cam follower which allows high radial loading and moderate axial loading with integrated cylindrical roller in double rows.</p> <p>Integrated concave grease nipples and hexagon sockets in both sides allow mounting and lubrication from either side.</p>
 <p>CFH-A Hexagon socket, Eccentric</p>	$\phi 5 \sim \phi 30$	<p>Available for the same mounting hole as general type.</p> <p>Compact and high accuracy eccentric cam followers with integral structure enables easy fine positioning adjustment simply by rotating stud due to eccentric stud head shifting 0.2 to 1mm from stud mounting axis.</p> <p>Drastic reduction of machining and assembling process is enabled by eliminating positioning against cam groove or high accuracy machining of mounting holes.</p> <p>Available with stainless steel type (code M) for higher corrosive resistance.</p>

Part Code

V: Full complement
None: With cage

UU: With seal
None: With shield

CF 16 V M

UU

R

N

Type **M:** Stainless steel
None: High carbon steel

R: Crowned outer ring
None: Cylindrical outer ring

Option
(Dedicated grease nipple)

V: Full complement
None: With cage

UU: With seal
None: With shield

CF 16 V M

UU

R

R: Crowned outer ring
None: Cylindrical outer ring

A

N

Type **M:** Stainless steel
None: High carbon steel

A: with hexagon socket on the stud head
B: with hexagon socket on the thread side
(Applicable shaft diameter $\phi 12 \sim \phi 30$)

Option
(Dedicated grease nipple)

V: Full complement
None: With cage

UU: With seal
None: With shield

CF 16 V M

UU

R

AB

R: Crowned outer ring
None: Cylindrical outer ring

AB: with hexagon socket on both sides.
(With integrated concave nipple)

Type **M:** Stainless steel
None: High carbon steel

NUCF 16 R AB

Type

AB: with hexagon socket on both sides.
(With integrated concave nipple)

R: Crowned outer ring
None: Cylindrical outer rings

V: Full complement
None: With cage

UU: With seal
None: With shield

CFH 16 V M

UU



R

A

R: Crowned outer ring
None: Cylindrical outer ring

A: with hexagon socket on the stud head
B: with hexagon socket on the thread side
(Applicable shaft diameter $\phi 12 \sim \phi 30$)
None: Standard typed

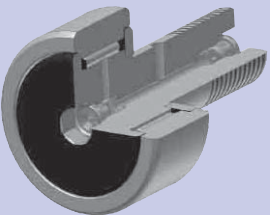
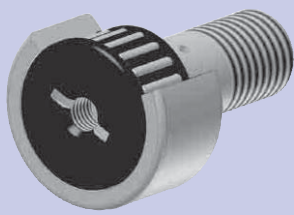
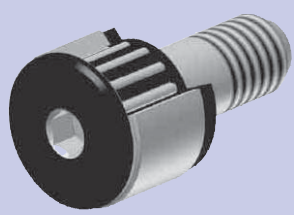
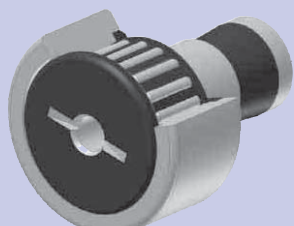
Type **M:** Stainless steel
None: High carbon steel

Type	Applicable axis diameter	Feature
 <p>CFH-AB</p>	$\phi 12 \sim \phi 30$	<p>Eccentric cam follower with integrated concave grease nipples on both sides. Available for mounting and lubrication with hexagon holes on both sides.</p> <p>Available with stainless steel type (code M) for higher corrosive resistance.</p>
 <p>CFT Lubrication tap hole</p>	$\phi 6 \sim \phi 30$	<p>Cam follower with tap for piping at stud head and thread of general type. Optimal for location that requires concentrated lubrication piping.</p> <p>Available with stainless steel type (code M) for higher corrosive resistance.</p>
 <p>CFS Compact outer ring</p>	$\phi 2.5 \sim \phi 6$	<p>Built-in very thin needle roller.</p> <p>Enables compact design due to very small outer ring diameter in comparison to stud diameter.</p> <p>Available with stainless steel type (code M) for higher corrosive resistance.</p>
 <p>CF-SFU Easy mounting</p>	$\phi 6 \sim \phi 20$	<p>A type with step on stud to allow easy mounting.</p> <p>Optimal for devices with limited space for stud tightening.</p> <p>Available with seal only.</p>
 <p>CR Inch type</p>	$\phi 4.826 \sim \phi 22.225$	Cam followers in inch dimension.

Part Code

V: Full complement
None: With cage

UU: With seal
None: With shield

R: Crowned outer ring
None: Cylindrical outer ring

CFH 16 V M

UU

R

AB

Type
M: Stainless steel
None: High carbon steel
AB: with hexagon socket on both sides (Applicable shaft diameter ϕ 12~ ϕ 30) (With integrated concave nipple)

V: Full complement
None: With cage

UU: With seal
None: With shield

R: Crowned outer ring
None: Cylindrical outer ring

CFT 16 V M

UU

R

A

CFT: Standard typed
CFHT: Eccentric type
M: Stainless steel
None: High carbon steel
A: with hexagon socket on the stud head (Applicable shaft diameter ϕ 12 ~ ϕ 30)
B: with hexagon socket on the thread side (Applicable shaft diameter ϕ 12 ~ ϕ 30)
None: Standard typed

CFS 6 V M A

Type
V: Full complement
None: With cage
M: Stainless steel
None: High carbon steel
A: with hexagon socket on the stud head

V: Full complement
None: With cage

CF-SFU 16 V R

16

V

R

Type
R: Crowned outer ring
None: Cylindrical outer ring

R: Crowned outer ring
None: Cylindrical outer ring

CR 16 UU R

UU

R

Type
UU: With seal
None: With shield

Structure and Features

Cam followers are compact and high rigid bearings with stud. It has a structure that an outer ring with built-in "roller" rolls over a track (raceway) and is utilized as guide roller for cam mechanism or linier motion. The cam follower is designed with a thick-walled outer ring in order to provide high rigidity to endure heavy load or impact load at contact portion with the track.

Outer rings have two shapes – crowned outer ring and cylindrical outer ring. The cylindrical outer ring is effective for heavy duty applications since it contacts with large contact area of the associated objects so that can mitigate the contact surface pressure. The crowned outer ring is suited for absorbing eccentric load since it absorbs angular misalignment due to a mount error. They have two internal structures – one with cage and one with full complement. Caged type cam followers are suited for high speed application, since the guiding feature of cage enables the rotation of "rollers" to be stable. Compared with caged type cam followers, full complement type is effective for applications with low-speed operation of heavy load due to its larger load rating. Full complement type also includes double-row cylindrical roller type which allows moderate axial loading.

Cam followers shall be fixed by tightening hexagon nut at stud thread by holding the stud with screw driver or hex-wrench.

Cam followers with eccentric axis on the stud thread have an advantage to adjust the variation of mounting position within its eccentric range, without requesting high machining accuracy of mounting hole position.

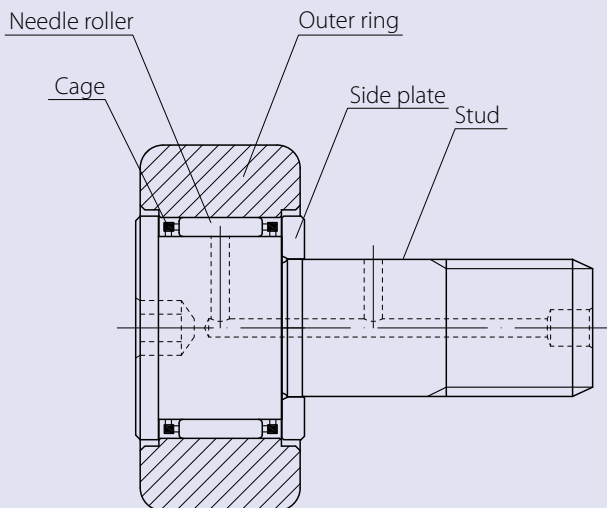

CF..Structure of type A

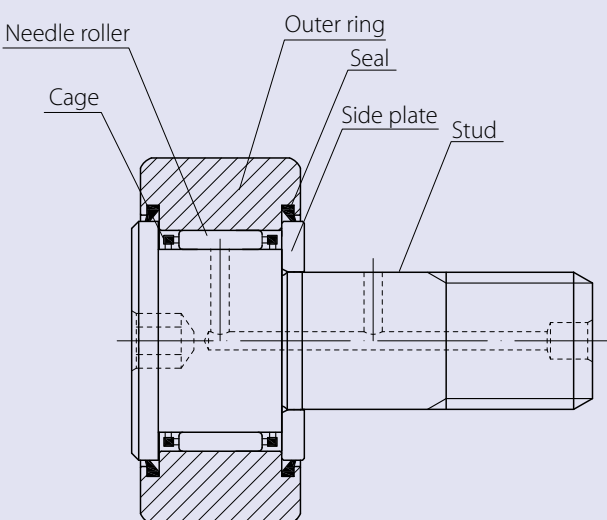

CF..UU Structure of type A

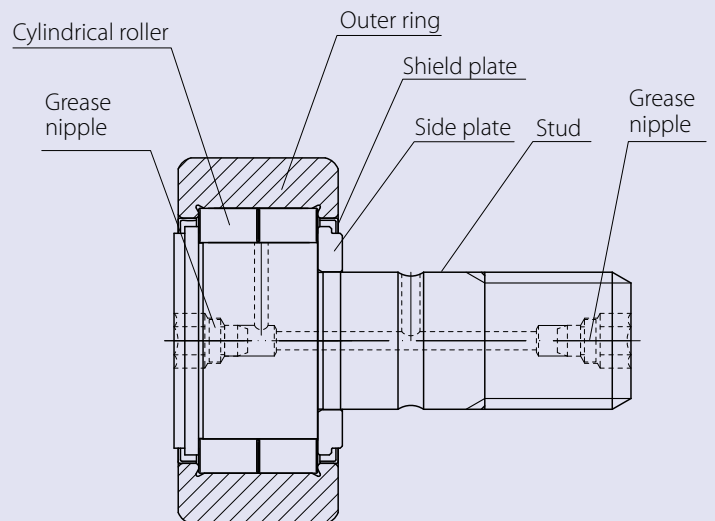

NUCF..Structure of type AB

Accuracy standard

Accuracy of cam follower is indicated in Table-1 and Table-2 below.

Table-1 Accuracy

Unit: μm

Name \ Category	Cam follower series in metric (CF--, NUCF--)		Compact type (CFS--)	Cam follower series in inch (CR--)	
	Crowned outer ring	Cylindrical outer ring	Cylindrical outer ring	Crowned outer ring	Cylindrical outer ring
Dimension tolerance of outer ring outer diameter (D)	0 -50	Refer to Table-2	Refer to Table-2	0 -50	0 -25
Dimension tolerance of stud diameter (d)	h7		h6	+25 0	
Dimension tolerance of outer ring width (C)	0 -120		0 -120	0 -130	

Table-2 Accuracy of outer ring (Metric series and compact type roller outer ring)

Unit: μm

Nominal outer ring outer diameter D (mm)		Dimension tolerance of mean outside diameter in a single plane Δ_{Dmp}		Radial runout of outer ring K_{ea}
Over	Incl.	high	low	max.
6 (5 or more)	18	0	-8	15
18	30	0	-9	15
30	50	0	-11	20
50	80	0	-13	25
80	120	0	-15	35

Radial internal clearance

Table below indicates radial internal clearance of cam follower.

Table-3 Radial internal clearance

Unit: μm

Part code				Radial internal clearance	
Cam follower series in metric (CF)	Compact type (CFS)	Double-row cylindrical roller cam follower (NUCF)	Inch type series (CR)	min.	max.
CF3 ~ 5	CFS2.5 ~ 5		CR8 ~ 8-1	3	17
CF6 ~ 8	CFS6		CR10 ~ 10-2	5	20
CF10 ~ 12-1			CR12 ~ 22	5	25
CF16 ~ 20-1			CR24 ~ 26	10	30
CF24 ~ 30-2				10	40
		NUCF16 ~ 24		0	25
		NUCF24-1 ~ 30-2		5	30

Fits

Cam followers require machining of mounting hole to eliminate play at fitting portion especially for the portion which is subjected to impact shock due to its application in cantilevered mounting. Table-4 indicates recommended fits between cam follower and its mounting hole.

Table-4 Dimension tolerance of stud mounting hole

Part code	Dimension tolerance of stud mounting hole
Cam follower series in metric (CF)	H7
Compact type (CFS)	H6
Double-row cylindrical roller cam follower (NUCF)	H7
Cam follower series in inch (CR)	F7

Maximum permissive load

Permissive load of cam follower is subjected to change in accordance with bending strength and shear strength of its stud in addition to standard rating load of needle bearing due to its design with stud. This load is indicated as maximum permissive load.

Track load capacity

Track load capacity means a permissive load under which the outer ring of cam follower and the mating surface are allowable to be used over a long period without causing any deformation nor compression mark. Track load capacity depicted in dimension table indicates a value for which hardness of steel mating material is assumed to be HRC40. In the case that the hardness of mating material is not HRC40, track load capacity in the dimension table shall be multiplied by value of track load factor obtained by Figure-1.

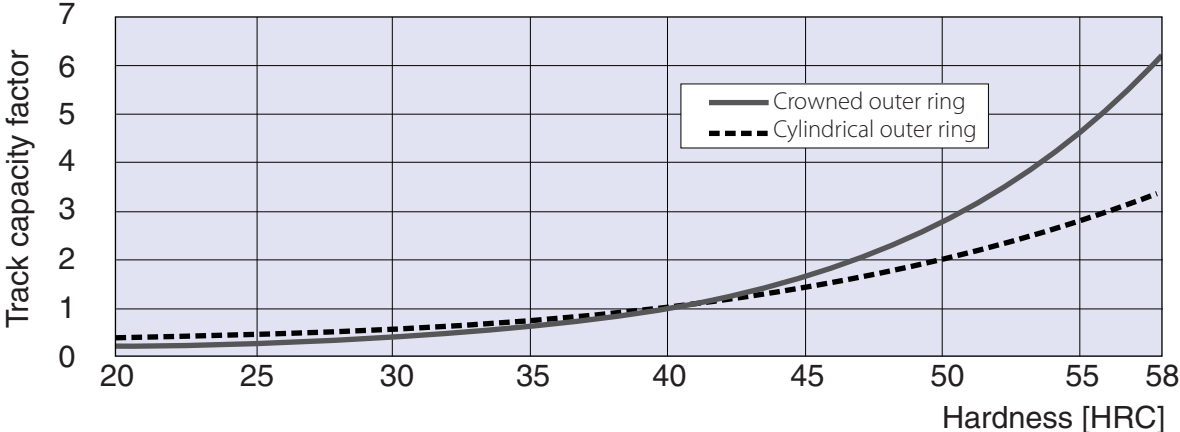

Figure-1 Track capacity factor

Lubrication

All the JNS cam followers are lubricated with pre-packed high quality lithium soap-based grease grade 2 (RoHS compliant) so that they are ready to use. For applications requiring high prevention measure against invasion of foreign matter or leakage of lubricant, products with seal(part conde--UU) which integrate special synthetic lubber with high abrasion resistance are also available.

Grease shall be packed up to volume approximately one-third to one-half of internal space of bearing. Lubrication interval varies depending on operation condition. Referential interval may be every six to twenty four months for cam followers with cages and every one to six months for full complement type with grease in the same type.

Some excessive grease may leak at the beginning of usage or immediately after re-greasing even for the products with seal. Aging operation period is recommended prior to application in which no contamination by grease is allowed in and around device. Wipe and clean any leaked extra grease after this operation.

Dedicated grease nipple shall be knocked in onto cam follower by pressing flange portion of the nipple using fixture shown in Figure-2.

Accessories

Accessories for cam follower of standard specification are shown in Table-5. Dedicated grease nipple is available upon customer request by ordering products with suffix "N" added to part code.

Also, type CF-AB and type NUCF-AB have integrated dedicated concave grease nipples installed at both sides.

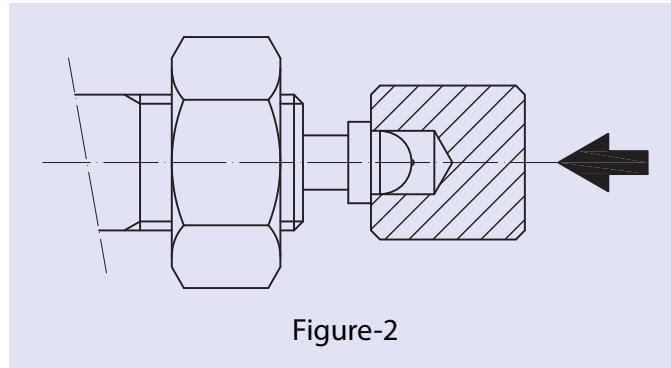





Figure-2

Example) CF 12 UUR -N
 └─ Dedicated grease nipple

Table-5 Accessories

Part code		 Stop plug ^{*1)}	 Resin plug ^{*2)}	 Hexagon nuts style 2	Grease
CF CFH CR	Without seal	Attached	Attached	Attached	Packed
	With seal	Attached	Attached	Attached	Packed
CFT	Without seal	—	—	Attached	Packed
	With seal	—	—	Attached	Packed
CFS		—	—	Attached	Packed
CF-SFU		Attached	Attached	—	Packed
NUCF		—	—	Attached	Packed

^{*1)} Stop plug is used for plugging unused lubrication hole(s).

^{*2)} Resin plug is used for preventing leakage of grease.

DIMENSIONS OF GREASE NIPPLES

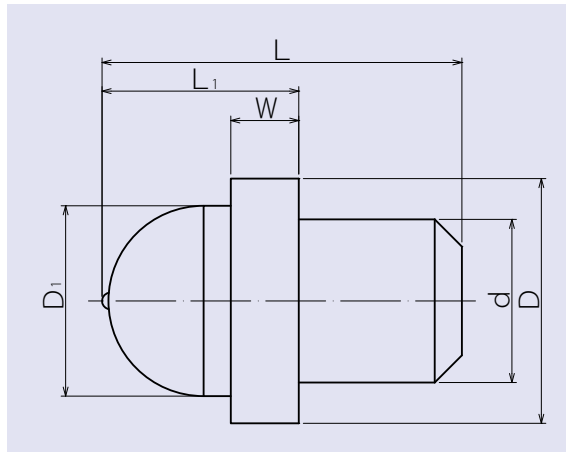

Table-6

Applicable part code	Nipple dimension					
	d	D	D ₁	L	L ₁	W
CF, CFH						
CF5	3.2	7.5	6	9	5.5	1.5
CF6 ~ CF10-1	4	7.5	6	10	5.5	1.5
CF12 ~ CF18	6	8	6	11	6	2
CF20 ~ CF30-2	8	10	6	16	7	3

Dimensions of supply nozzle for CF..AB type

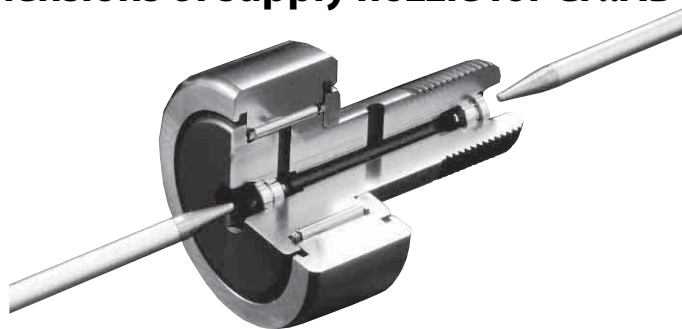

Table-7 Dimension of recommended lubrication nozzle (for CF..AB, NUCF..AB)

Type	Dimension and shape	Applied model number	
NPAB-1	<p>Technical drawing of the NPAB-1 nozzle. The total length is 135. The diameter of the main body is 6. The diameter of the tip is 1.5. The tip has a 20-degree taper. The nozzle has a threaded end with an Rc1/8 connection.</p>	CF10ABK(M10 × 1) CF10-1ABK(M10 × 1) CF12AB CF12-1AB CF16AB CF18AB	NUCF16AB NUCF18AB
NPAB-2	<p>Technical drawing of the NPAB-2 nozzle. The total length is 130. The diameter of the main body is 6. The nozzle has a threaded end with an Rc1/8 connection and a fillet with a radius of R2.5.</p>	CF20AB CF20-1AB CF24AB CF24-1AB CF30AB CF30-1AB CF30-2AB	NUCF20AB NUCF20-1AB NUCF24AB NUCF24-1AB NUCF30AB NUCF30-2AB

Mounting

Mounting part

Hole for stud shall be perpendicular to mounting surface so as to ensure even contact between outer ring and rolling surface of mating material. Corner chamfer of hole shall be as small as around C0.5. Counter bore diameter shall be dimension f or more as described in the dimension table.

Type CF-R with crowned outer ring is recommended in the case of application with insufficient contact between outer ring and rolling surface of mating material.

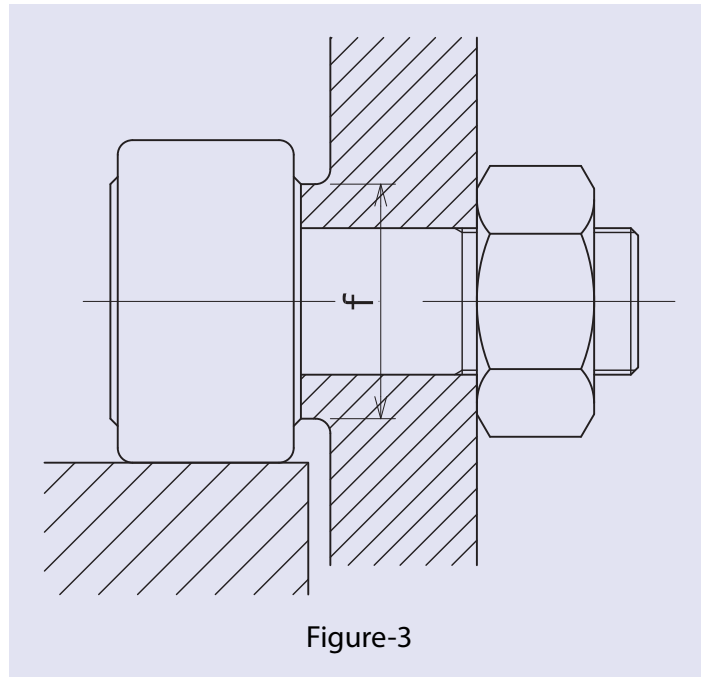

Figure-3

Mounting method

- Cam follower shall be mounted so as not to incline against direction of the motion.
- Mounting method to tighten cam follower directly to bracket by adding female thread to it without using nut as depicted in Figure-4 (A) is NOT recommended. This method may cause damage on stud due to concentration of bending stress in male thread portion in the event of loosening since it is difficult to tighten the stud sufficiently.

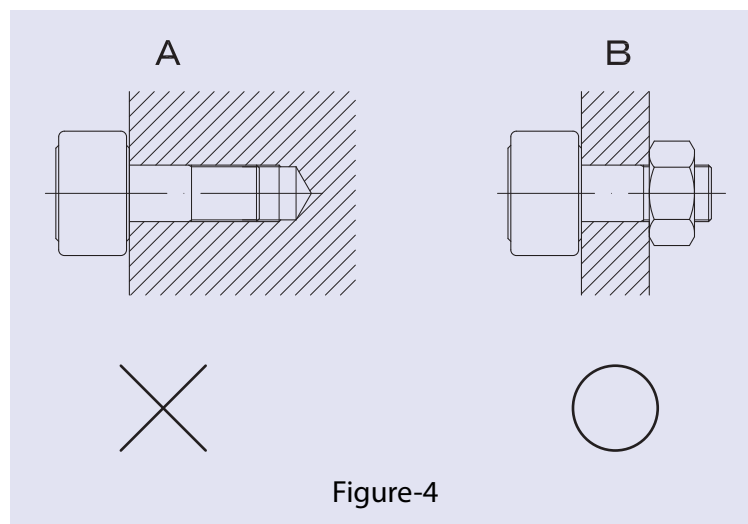
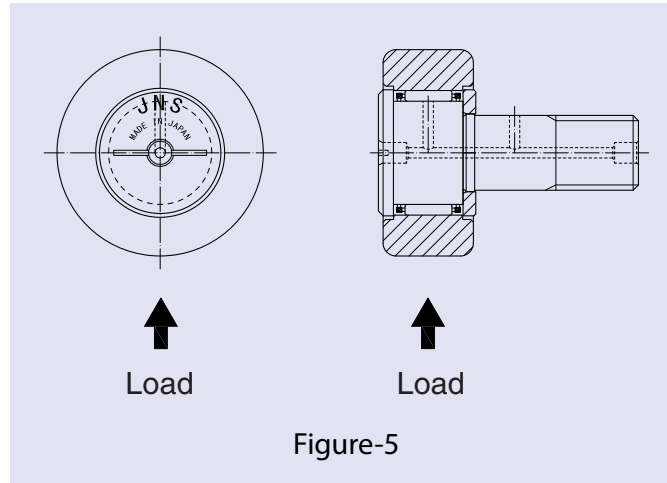

Figure-4

- For application with heavy load, lubrication hole of stud shall be located outside of loading range (on the side to receive load). Location of the lubrication hole is indicated by "JNS" marking on the side of stud flange. (Refer to Figure-5)

Hole at the center of stud is used as stopper for tightening or lubricant supply hole for grease lubrication.



Precaution for using spring washer

It is important to ensure that spring washer used for mounting cam follower has no burr or sharp edge. Debris scraped from nut or mounting bracket by burr or sharp edge of washer during tightening can invade stud thread and can cause insufficient tightness or damage to thread.

Tightening torque of stud

Stud of cam follower is subjected to bending stress or tensile stress by bearing load. Tightening torque shall be set not to exceed the value in the dimension table.

Using double spring washers, double thin nut of JIS B 1181 or special nut with locking feature is recommended in the case of possible loosening of mounting screw due to vibration or impact shock.

Mounting of eccentric cam follower

Adjustment of eccentric shall be performed in accordance with the following procedure.

- (1) Insert stud to mounting hole and tighten nut as the stud can turn loosely. Marking of stud shall face location indicated in Figure-6 in relation to direction of load.
- (2) Gap between cam follower and mating contact surface may be adjusted by turning stud using hexagon hole on the stud head.
- (3) After completing adjustment, tighten nut with holding rotation of stud. Make it sure not to exceed maximum tightening torque of the nut.

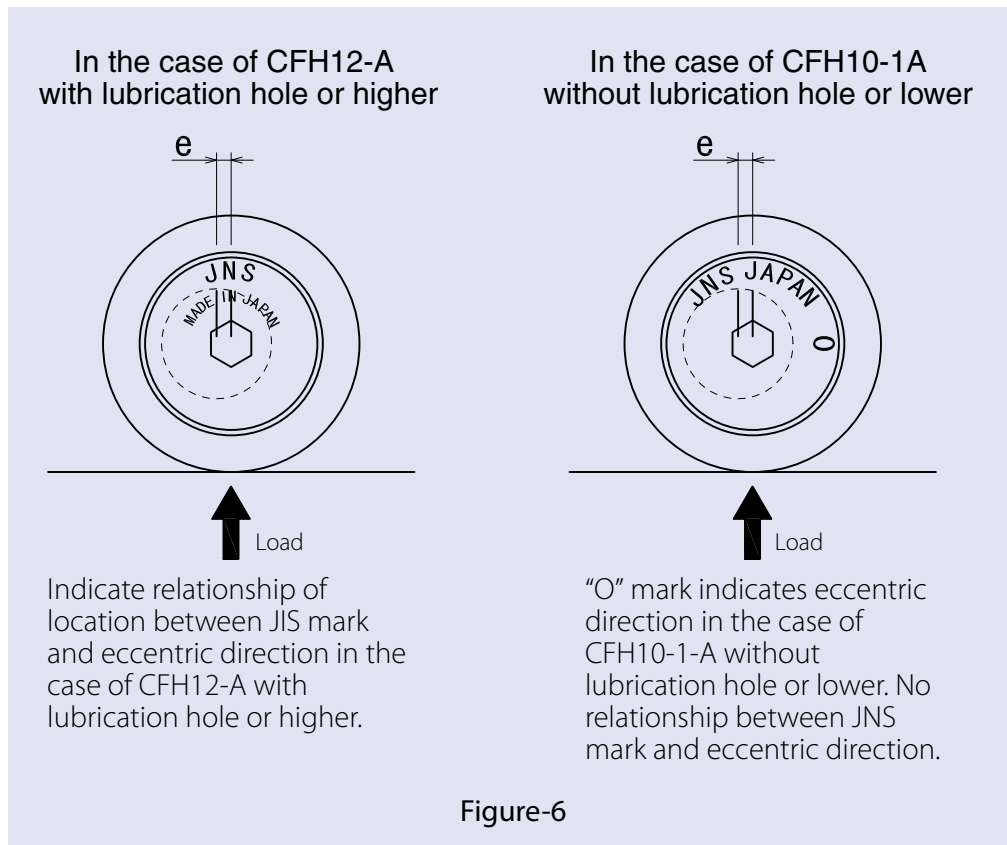

Mounting of CF-SFU type

Refer to Figure-7 for mounting method of easy mounting of CF-SFU type.

Type CF-SFU is NOT recommended for application in the part subjected to vibration or shock impact as much as its mounting is simple. Standard cam followers with nut are recommended for application with possible vibration or shock impact.

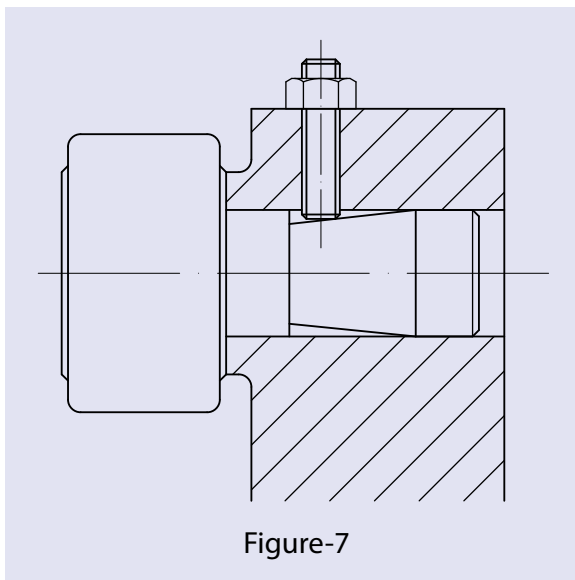

CAM FOLLOWERS

MINIATURE TYPE
HEXAGON SOCKET ON STUD HEAD

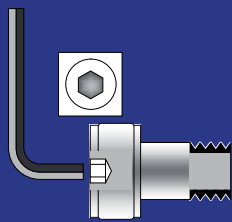

CFS..A



CFS..VA

CFS..A TYPE





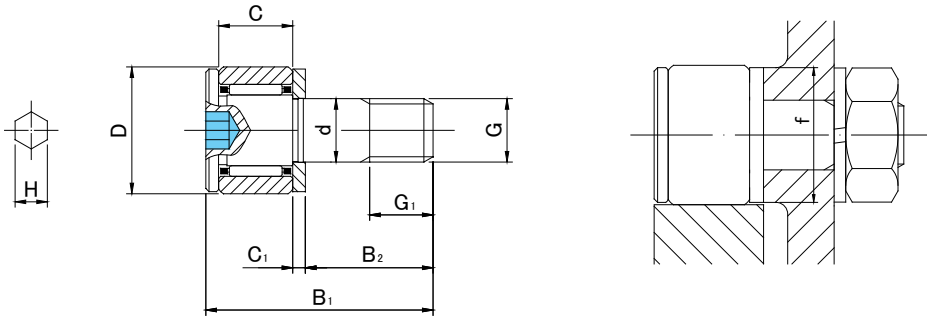

Stud diameter (mm)	Designation	Dimensions (mm)										
		Cylindrical outer ring										
h6 tolerance	With cage	Full roller	D	C	d	G	G1	B1	B2	C1	H	
2.5 0 -0.006	CFS 2.5A	—	5	3	2.5	M2.5×0.45	2.5	9.5	5	0.7	0.9	
	—	CFS 2.5VA										
3 0 -0.006	CFS 3A	—	6	4	3	M3×0.5	3	11.5	6	0.7	1.5	
	—	CFS 3VA										
4 0 -0.008	CFS 4A	—	8	5	4	M4×0.7	4	15	8	1	2	
	—	CFS 4VA										
5 0 -0.008	CFS 5A	—	10	6	5	M5×0.8	5	18	10	1	2.5	
	—	CFS 5VA										
6 0 -0.008	CFS 6A	—	12	7	6	M6×1	6	21.5	12	1.2	3	
	—	CFS 6VA										

OUTER RINGS TOLERANCE (μm)

TYPE	Cylindrical outer ring
CFS2.5,CFS3,CFS4,CFS5,CFS6	0/-8



Prepacked Grease

	Basic dynamic load rating	Basic static load rating	Largest permissible load	Max tightening torque	Mass
					
f min	Cr N	Cor N	N	N·m	g (approx)
4.8	410	335	260	0.2	1
	1 000	1 080	260		
5.8	630	610	360	0.3	2
	1 370	1 770	360		
7.7	1 080	1 080	780	0.6	4
	2 350	3 040	780		
9.6	1 570	1 860	1 420	1.3	7
	3 140	4 710	1 420		
11.6	2 060	2 160	2 110	2.3	13
	4 610	6 270	2 110		

CFS...A



ACCESSORIES

TYPE	
All types	NUT Attached

CAM FOLLOWERS

EASY MOUNTING TYPE
SCREWDRIVER SLOT HEAD

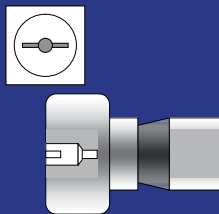

CF-SFU



CF-SFU.V

CF-SFU TYPE

Stud diameter (mm)	Designation R500(CF6~CF18) R1000(CF20≤)	Dimensions (mm)															Mounting dimensions (mm)																						
		Cylindrical outer ring		Crowned outer ring		D			C			d			B1			B2			C1			L1			L2			d1			e			r _{s min}			D1 Tolerance
h7 tolerance	With seals	With seals	D	C	d	B1	B2	C1	L1	L2	d1	e	r _{s min}	D1 Tolerance																									
6	CF-SFU-6	CF-SFU-6R	16	11	6	32	20	0.6	5	10	4	0.3	0.3	6 ⁰ _{+0.012}																									
	CF-SFU-6V	CF-SFU-6VR																																					
8	CF-SFU-8	CF-SFU-8R	19	11	8	32	20	0.6	5	10	4	0.5	0.3	8 ⁰ _{+0.015}																									
	CF-SFU-8V	CF-SFU-8VR																																					
10	CF-SFU-10	CF-SFU-10R	22	12	10	33	20	0.6	5	10	4	0.5	0.3	10 ⁰ _{+0.015}																									
	CF-SFU-10V	CF-SFU-10VR																																					
10	CF-SFU-10-1	CF-SFU-10-1R	26	12	10	33	20	0.6	5	10	4	0.5	0.3	10 ⁰ _{+0.015}																									
	CF-SFU-10-1V	CF-SFU-10-1VR																																					
12	CF-SFU-12	CF-SFU-12R	30	14	12	35	20	0.6	5	10	6	1	0.6	12 ⁰ _{+0.018}																									
	CF-SFU-12V	CF-SFU-12VR																																					
12	CF-SFU-12-1	CF-SFU-12-1R	32	14	12	35	20	0.6	5	10	6	1	0.6	12 ⁰ _{+0.018}																									
	CF-SFU-12-1V	CF-SFU-12-1VR																																					
16	CF-SFU-16	CF-SFU-16R	35	18	16	44.5	25	0.8	10	10	6	1	0.6	16 ⁰ _{+0.018}																									
	CF-SFU-16V	CF-SFU-16VR																																					
18	CF-SFU-18	CF-SFU-18R	40	20	18	46.5	25	0.8	10	10	6	1	1	18 ⁰ _{+0.018}																									
	CF-SFU-18V	CF-SFU-18VR																																					
20	CF-SFU-20	CF-SFU-20R	52	24	20	50.5	25	0.8	10	10	8	1	1	20 ⁰ _{+0.021}																									
	CF-SFU-20V	CF-SFU-20VR																																					
20	CF-SFU-20-1	CF-SFU-20-1R	47	24	20	50.5	25	0.8	10	10	8	1	1	20 ⁰ _{+0.021}																									
	CF-SFU-20-1V	CF-SFU-20-1VR																																					

OUTER RINGS TOLERANCE (μm)

TYPE	Cylindrical outer ring	Crowned outer ring
CF6	0/-8	0/-50
CF8,CF10,CF10-1,CF12	0/-9	0/-50
CF12-1,CF16,CF18,CF20-1	0/-11	0/-50
CF20	0/-13	0/-50

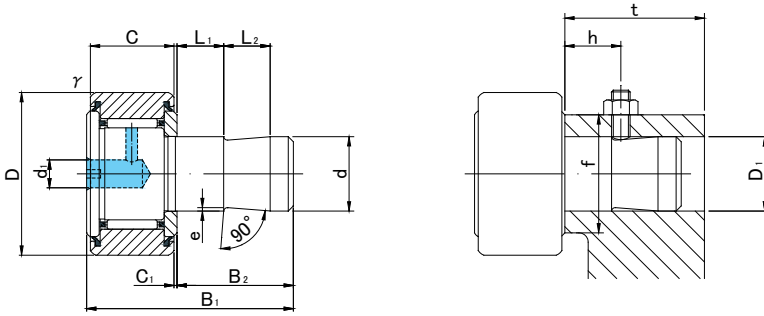

Prepacked Grease

			Basic dynamic load rating	Basic static load rating	Largest permissible load	Track load capacity		Mass
t Min	f Min	h (Ref)	Cr N	Cor N	N	Cylindrical outer ring N	Crowned outer ring N	g (approx)
20	11	10	3 630	3 630	2 110	3 430	1 080	19
			6 960	8 530	2 110	3 430	1 080	
20	13	10	4 310	4 710	4 710	4 020	1 370	28.5
			8 130	11 170	4 710	4 020	1 370	
20	15	10	5 390	6 860	6 860	4 700	1 670	43
			9 510	14 500	7 450	4 700	1 670	
20	15	10	5 390	6 860	6 860	5 490	2 060	58.5
			9 510	14 500	7 450	5 490	2 060	
20	20	10	7 940	9 800	9 800	7 060	2 450	93
			13 430	19 700	11 270	7 060	2 450	
20	20	10	7 940	9 800	9 800	7 450	2 740	103
			13 430	19 700	11 270	7 450	2 740	
25	24	15	12 050	18 330	18 330	11 200	3 140	164
			20 680	37 630	19 800	11 200	3 140	
25	26	15	14 700	25 200	25 200	14 400	3 720	235
			25 280	51 350	26 560	14 400	3 720	
25	36	15	20 680	34 600	32 140	23 200	8 230	436
			33 120	64 480	32 140	23 200	8 230	
25	36	15	20 680	34 600	32 140	21 000	7 150	361
			32 120	64 480	32 140	21 000	7 150	

ACCESSORIES

TYPE		
	STOP PLUG	RESIN PLUG
CF6/CF8/CF10/CF10-1	—	φ 4 Attached
CF12/CF12-1/CF16/CF18	φ 6 Attached	φ 6 Attached
CF20/CF20-1	φ 8 Attached	φ 8 Attached



CAM FOLLOWERS

HEXAGON SOCKET ON STUD HEAD

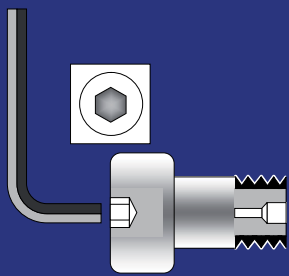

CF..A



CF..VA

CF..A TYPE

CF..A



Stud diameter (mm)	h7 tolerance	Designation				Dimensions (mm)						
		Cylindrical outer ring		Crowned outer ring R250(≤ CF5) R500(CF6 ~ CF10)		D	C	d	G	G1	B1	B2
		Without seals	With seals	Without seals	With seals							
3	0 -0.010	CF 3A	CF 3UUA	CF 3RA	CF 3UURA	10	7	3	M3×0.5	5	17	9
		CF 3VA	CF 3VUUA	CF 3VRA	CF 3VUURA							
4	0 -0.012	CF 4A	CF 4UUA	CF 4RA	CF 4UURA	12	8	4	M4×0.7	6	20	11
		CF 4VA	CF 4VUUA	CF 4VRA	CF 4VUURA							
5	0 -0.012	CF 5A	CF 5UUA	CF 5RA	CF 5UURA	13	9	5	M5×0.8	7.5	23	13
		CF 5VA	CF 5VUUA	CF 5VRA	CF 5VUURA							
6	0 -0.012	CF 6A	CF 6UUA	CF 6RA	CF 6UURA	16	11	6	M6×1	8	28	16
		CF 6VA	CF 6VUUA	CF 6VRA	CF 6VUURA							
8	0 -0.015	CF 8A	CF 8UUA	CF 8RA	CF 8UURA	19	11	8	M8×1.25	10	32	20
		CF 8VA	CF 8VUUA	CF 8VRA	CF 8VUURA							
10	0 -0.015	CF10A	CF10UUA	CF10RA	CF10UURA	22	12	10	M10×1.25	12	36	23
		CF10VA	CF10VUUA	CF10VRA	CF10VUURA							
10	0 -0.015	CF10-1A	CF10-1UUA	CF10-1RA	CF10-1UURA	26	12	10	M10×1.25	12	36	23
		CF10-1VA	CF10-1VUUA	CF10-1VRA	CF10-1VUURA							
10	0 -0.015	CF10AK	CF10UUAk	CF10RAk	CF10UURAK	22	12	10	M10×1	12	36	23
		CF10VAK	CF10VUUAk	CF10VRAk	CF10VUURAK							
10	0 -0.015	CF10-1AK	CF10-1UUAk	CF10-1RAk	CF10-1UURAK	26	12	10	M10×1	12	36	23
		CF10-1VAK	CF10-1VUUAk	CF10-1VRAk	CF10-1VUURAK							

* Without seals, suitable for grease lubrication. In case of oil lubrication, up to 130% of this value shall be permissible, and 70% of this value shall apply for types with seals.

OUTER RINGS TOLERANCE (μm)

TYPE	Cylindrical outer ring	Crowned outer ring
CF3,CF4,CF5,CF6	0/-8	0/-50
CF8,CF10,CF10-1,CF12	0/-9	0/-50
CF12-1,CF16,CF18,CF20-1	0/-11	0/-50
CF20,CF24,CF24-1,CF30	0/-13	0/-50
CF30-1,CF30-2	0/-15	0/-50

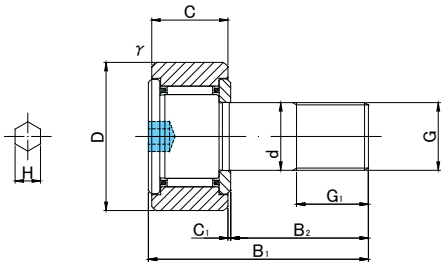

CF3(V)A~CF10-1(V)A

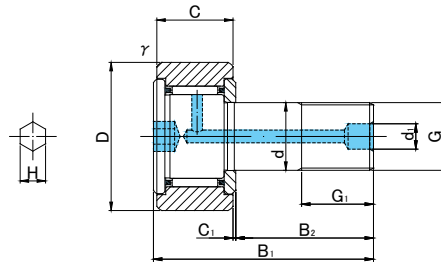

CF10(V)AK~CF10-1(V)AK

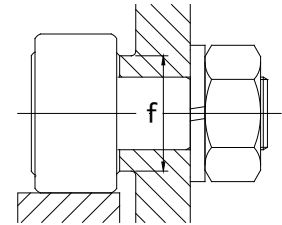

Prepacked Grease

							Basic dynamic load rating	Basic static load rating	Largest permissible load	Limiting speed *	Track load capacity		Max tightening torque	Mass
B3	C1	d1	d2	H	r_s min	f min	Cr N	Cor N	N	rpm	Cylindrical outer ring N	Crowned outer ring N	N-m	g (approx)
—	0.5	—	—	2	0.2	6.8	1 470	1 180	360	47 000	1 370	540	0.4	4.5
							2 800	2 500	360	18 800				
—	0.5	—	—	2.5	0.3	8.6	2 060	2 050	780	37 000	1 760	690	1	7.5
							4 000	4 300	780	14 800				
—	0.5	—	—	3	0.3	9.7	3 140	2 770	1 420	29 000	2 250	780	2	10.5
							5 100	5 500	1 420	11 600				
—	0.6	—	—	3	0.3	11	3 630	3 630	2 110	25 000	3 430	1 080	3	18.5
							6 960	8 530	2 110	12 000				
—	0.6	—	—	4	0.3	13	4 310	4 710	4 710	20 000	4 020	1 370	8	28.5
							8 130	11 170	4 710	9 000				
—	0.6	—	—	5	0.3	15	5 390	6 860	6 860	17 000	4 700	1 670	15	45
							9 510	14 500	7 450	7 500				
—	0.6	—	—	5	0.3	15	5 390	6 860	6 860	17 000	5 490	2 060	15	60
							9 510	14 500	7 450	7 500				
—	0.6	4	—	5	0.3	15	5 390	6 860	6 860	17 000	4 700	1 670	15	45
							9 510	14 500	7 450	7 500				
—	0.6	4	—	5	0.3	15	5 390	6 860	6 860	17 000	5 490	2 060	15	60
							9 510	14 500	7 450	7 500				

CF..A



ACCESSORIES

TYPE			
CF3/CF4/CF5/CF6/CF8/CF10/CF10-1	—	—	Attached
CF10K/CF10-1K	φ 4 Attached	φ 4 Attached	Attached
CF12/CF12-1/CF16/CF18	φ 6 Attached	φ 6 Attached	Attached
CF20/CF20-1/CF24/CF24-1/CF30/CF30-1/CF30-2	φ 8 Attached	φ 8 Attached	Attached

CAM FOLLOWERS

HEXAGON SOCKET ON STUD HEAD

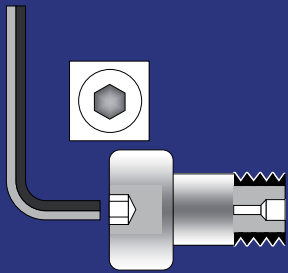

CF..A



CF..VA

CF..A TYPE

Stud diameter (mm)	h7 tolerance	Designation				Dimensions (mm)						
		Cylindrical outer ring		Crowned outer ring R500(CF12 ~ CF18) R1000(CF20 ≤)		D	C	d	G	G1	B1	B2
		Without seals	With seals	Without seals	With seals							
12	0 -0.018	CF12A	CF12UUA	CF12RA	CF12UURA	30	14	12	M12×1.5	13	40	25
		CF12VA	CF12VUUA	CF12VRA	CF12VUURA							
12	0 -0.018	CF12-1A	CF12-1UUA	CF12-1RA	CF12-1UURA	32	14	12	M12×1.5	13	40	25
		CF12-1VA	CF12-1VUUA	CF12-1VRA	CF12-1VUURA							
16	0 -0.018	CF16A	CF16UUA	CF16RA	CF16UURA	35	18	16	M16×1.5	17	52	32.5
		CF16VA	CF16VUUA	CF16VRA	CF16VUURA							
18	0 -0.018	CF18A	CF18UUA	CF18RA	CF18UURA	40	20	18	M18×1.5	19	58	36.5
		CF18VA	CF18VUUA	CF18VRA	CF18VUURA							
20	0 -0.021	CF20A	CF20UUA	CF20RA	CF20UURA	52	24	20	M20×1.5	21	66	40.5
		CF20VA	CF20VUUA	CF20VRA	CF20VUURA							
20	0 -0.021	CF20-1A	CF20-1UUA	CF20-1RA	CF20-1UURA	47	24	20	M20×1.5	21	66	40.5
		CF20-1VA	CF20-1VUUA	CF20-1VRA	CF20-1VUURA							
24	0 -0.021	CF24A	CF24UUA	CF24RA	CF24UURA	62	29	24	M24×1.5	25	80	49.5
		CF24VA	CF24VUUA	CF24VRA	CF24VUURA							
24	0 -0.021	CF24-1A	CF24-1UUA	CF24-1RA	CF24-1UURA	72	29	24	M24×1.5	25	80	49.5
		CF24-1VA	CF24-1VUUA	CF24-1VRA	CF24-1VUURA							
30	0 -0.021	CF30A	CF30UUA	CF30RA	CF30UURA	80	35	30	M30×1.5	32	100	63
		CF30VA	CF30VUUA	CF30VRA	CF30VUURA							
30	0 -0.021	CF30-1A	CF30-1UUA	CF30-1RA	CF30-1UURA	85	35	30	M30×1.5	32	100	63
		CF30-1VA	CF30-1VUUA	CF30-1VRA	CF30-1VUURA							
30	0 -0.021	CF30-2A	CF30-2UUA	CF30-2RA	CF30-2UURA	90	35	30	M30×1.5	32	100	63
		CF30-2VA	CF30-2VUUA	CF30-2VRA	CF30-2VUURA							

* Without seals, suitable for grease lubrication. In case of oil lubrication, up to 130% of this value shall be permissible, and 70% of this value shall apply for types with seals.

OUTER RINGS TOLERANCE (μm)

TYPE	Cylindrical outer ring	Crowned outer ring
CF3,CF4,CF5,CF6	0/-8	0/-50
CF8,CF10,CF10-1,CF12	0/-9	0/-50
CF12-1,CF16,CF18,CF20-1	0/-11	0/-50
CF20,CF24,CF24-1,CF30	0/-13	0/-50
CF30-1,CF30-2	0/-15	0/-50

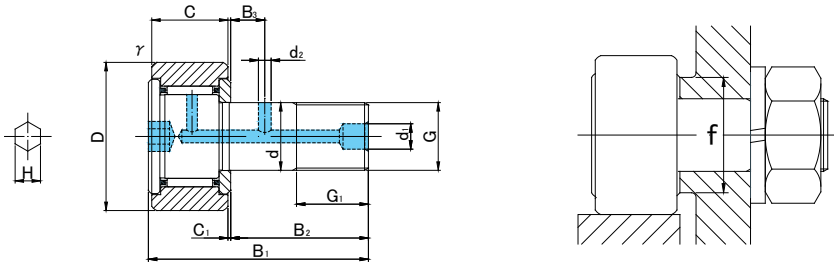

CF12(V)A~CF30-2(V)A

Prepacked Grease

							Basic dynamic load rating	Basic static load rating	Largest permissible load	Limiting speed *	Track load capacity		Max tightening torque	Mass
B3	C1	d1	d2	H	r_s min	f min	Cr N	Cor N	N	rpm	Cylindrical outer ring N	Crowned outer ring N	N·m	g (approx)
6	0.6	6	3	6	0.6	20	7 940	9 800	9 800	14 000	7 060	2 450	22	95
							13 430	19 700	11 270	6 000				
6	0.6	6	3	6	0.6	20	7 940	9 800	9 800	14 000	7 450	2 740	22	105
							13 430	19 700	11 270	6 000				
8	0.8	6	3	6	0.6	24	12 050	18 330	18 330	10 000	11 200	3 140	58	170
							20 680	37 630	19 800	4 500				
8	0.8	6	3	6	1	26	14 700	25 200	25 200	8 500	14 400	3 720	87	250
							25 280	51 350	26 560	3 500				
9	0.8	8	4	8	1	36	20 680	34 600	32 140	7 000	23 200	8 230	120	460
							33 120	64 480	32 140	3 500				
9	0.8	8	4	8	1	36	20 680	34 600	32 140	7 000	21 000	7 150	120	385
							33 120	64 480	32 140	3 500				
11	0.8	8	4	8	1	40	30 480	52 630	49 500	6 500	34 200	10 500	220	815
							46 550	92 020	49 500	3 000				
11	0.8	8	4	8	1	40	30 480	52 630	49 500	6 500	39 800	12 900	220	1 140
							46 550	92 020	49 500	3 000				
15	1	8	4	8	1	46	45 370	85 060	73 700	5 000	52 600	14 900	450	1 870
							67 620	144 060	73 700	2 200				
15	1	8	4	8	1	46	45 370	85 060	73 700	5 000	56 000	56 000	450	2 030
							67 620	144 060	73 700	2 200				
15	1	8	4	8	1	46	45 370	85 060	73 700	5 000	59 300	59 300	450	2 220
							67 620	144 060	73 700	2 200				

ACCESSORIES

TYPE			
	STOP PLUG	RESIN PLUG	NUT
CF3/CF4/CF5/CF6/CF8/CF10/CF10-1	—	—	Attached
CF10K/CF10-1K	φ 4 Attached	φ 4 Attached	Attached
CF12/CF12-1/CF16/CF18	φ 6 Attached	φ 6 Attached	Attached
CF20/CF20-1/CF24/CF24-1/CF30/CF30-1/CF30-2	φ 8 Attached	φ 8 Attached	Attached

CF..A



CAM FOLLOWERS

HEXAGON SOCKET ON BOTH SIDES
GREASE NIPPLE INSTALLED

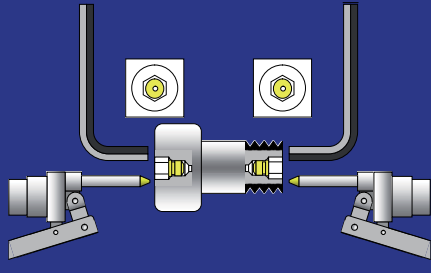

CF..AB



CF..VAB

CF..AB TYPE

Stud diameter (mm)	h7 tolerance	Designation				Dimensions (mm)							
		Cylindrical outer ring		Crowned outer ring R500(CF10 ~ CF18) R1000(CF20 ≤)		D	C	d	G	G1	B1	B2	
		Without seals	With seals	Without seals	With seals								
10	0 -0.015	CF10ABK	CF10UUABK	CF10RABK	CF10URABK	22	12	10	M10×1	12	36	23	
		CF10VABK	CF10VUUABK	CF10VRABK	CF10VURABK								
10	0 -0.015	CF10-1ABK	CF10-1UUABK	CF10-1RABK	CF10-1URABK	26	12	10	M10×1	12	36	23	
		CF10-1VABK	CF10-1VUUABK	CF10-1VRABK	CF10-1VURABK								
12	0 -0.018	CF12AB	CF12UUAB	CF12RAB	CF12URAB	30	14	12	M12×1.5	13	40	25	
		CF12VAB	CF12VUUAB	CF12VRAB	CF12VURAB								
12	0 -0.018	CF12-1AB	CF12-1UUAB	CF12-1RAB	CF12-1URAB	32	14	12	M12×1.5	13	40	25	
		CF12-1VAB	CF12-1VUUAB	CF12-1VRAB	CF12-1VURAB								
16	0 -0.018	CF16AB	CF16UUAB	CF16RAB	CF16URAB	35	18	16	M16×1.5	17	52	32.5	
		CF16VAB	CF16VUUAB	CF16VRAB	CF16VURAB								
18	0 -0.018	CF18AB	CF18UUAB	CF18RAB	CF18URAB	40	20	18	M18×1.5	19	58	36.5	
		CF18VAB	CF18VUUAB	CF18VRAB	CF18VURAB								
20	0 -0.021	CF20AB	CF20UUAB	CF20RAB	CF20URAB	52	24	20	M20×1.5	21	66	40.5	
		CF20VAB	CF20VUUAB	CF20VRAB	CF20VURAB								

CF..AB TYPE has oil holes (grease nipple) which are prepared in the stud head and thread side, also an oil hole is prepared in the outer surface of stud.

* Without seals, suitable for grease lubrication. In case of oil lubrication, up to 130% of this value shall be permissible, and 70% of this value shall apply for types with seals.

OUTER RINGS TOLERANCE (μm)

TYPE	Cylindrical outer ring	Crowned outer ring
CF10,CF10-1,CF12	0/-9	0/-50
CF12-1,CF16,CF18,CF20-1	0/-11	0/-50
CF20,CF24,CF24-1,CF30	0/-13	0/-50
CF30-1,CF30-2	0/-15	0/-50

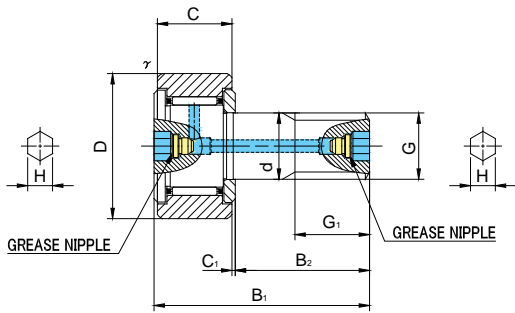

CF10(V)ABK~CF10-1(V)ABK

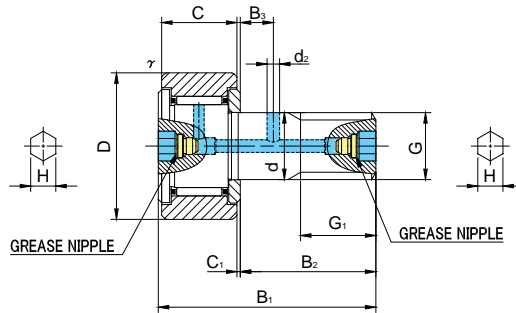

CF12(V)AB~CF18(V)AB

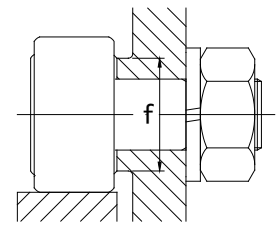

Packed Grease

						Basic dynamic load rating	Basic static load rating	Largest permissible load	Limiting speed *	Track load capacity		Max tightening torque	Mass
B3	C1	d2	H	r_s min	f min	Cr N	Cor N	N	rpm	Cylindrical outer ring N	Crowned outer ring N	N·m	g (approx)
—	0.6	—	5	0.3	15	5 390	6 860	6 860	17 000	4 700	1 670	15	45
						9 510	14 500	7 450	7 500				
—	0.6	—	5	0.3	15	5 390	6 860	6 860	17 000	5 490	2 060	15	60
						9 510	14 500	7 450	7 500				
6	0.6	3	6	0.6	20	7 940	9 800	9 800	14 000	7 060	2 450	22	95
						13 430	19 700	11 270	6 000				
6	0.6	3	6	0.6	20	7 940	9 800	9 800	14 000	7 450	2 740	22	105
						13 430	19 700	11 270	6 000				
8	0.8	3	6	0.6	24	12 050	18 330	18 330	10 000	11 200	3 140	58	170
						20 680	37 630	19 800	4 500				
8	0.8	3	6	1	26	14 700	25 200	25 200	8 500	14 400	3 720	87	250
						25 280	51 350	26 560	3 500				
9	0.8	4	8	1	36	20 680	34 600	32 140	7 000	23 200	8 230	120	460
						33 120	64 480	32 140	3 500				

ACCESSORIES

TYPE		
All types	Installed	Attached

CF..AB



CAM FOLLOWERS

HEXAGON SOCKET ON BOTH SIDES
GREASE NIPPLE INSTALLED

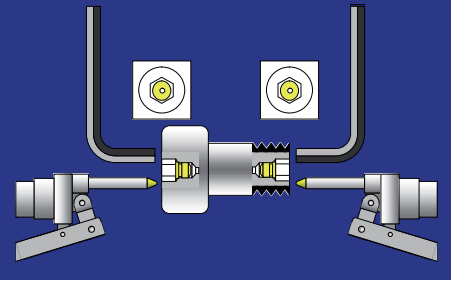

CF..AB



CF..VAB

CF..AB TYPE

Stud diameter (mm)	h7 tolerance	Designation				Dimensions (mm)							
		Cylindrical outer ring		Crowned outer ring R1000(CF20 ≤)		D	C	d	G	G1	B1	B2	
		Without seals	With seals	Without seals	With seals								
20	0 -0.021	CF20-1AB	CF20-1UUAB	CF20-1RAB	CF20-1UURAB	47	24	20	M20×1.5	21	66	40.5	
		CF20-1VAB	CF20-1VUUAB	CF20-1VRAB	CF20-1VUURAB								
24	0 -0.021	CF24AB	CF24UUAB	CF24RAB	CF24UURAB	62	29	24	M24×1.5	25	80	49.5	
		CF24VAB	CF24VUUAB	CF24VRAB	CF24VUURAB								
24	0 -0.021	CF24-1AB	CF24-1UUAB	CF24-1RAB	CF24-1UURAB	72	29	24	M24×1.5	25	80	49.5	
		CF24-1VAB	CF24-1VUUAB	CF24-1VRAB	CF24-1VUURAB								
30	0 -0.021	CF30AB	CF30UUAB	CF30RAB	CF30UURAB	80	35	30	M30×1.5	32	100	63	
		CF30VAB	CF30VUUAB	CF30VRAB	CF30VUURAB								
30	0 -0.021	CF30-1AB	CF30-1UUAB	CF30-1RAB	CF30-1UURAB	85	35	30	M30×1.5	32	100	63	
		CF30-1VAB	CF30-1VUUAB	CF30-1VRAB	CF30-1VUURAB								
30	0 -0.021	CF30-2AB	CF30-2UUAB	CF30-2RAB	CF30-2UURAB	90	35	30	M30×1.5	32	100	63	
		CF30-2VAB	CF30-2VUUAB	CF30-2VRAB	CF30-2VUURAB								

CF..AB TYPE has oil holes (grease nipple) which are prepared in the stud head and thread side, also an oil hole is prepared in the outer surface of stud.

* Without seals, suitable for grease lubrication. In case of oil lubrication, up to 130% of this value shall be permissible, and 70% of this value shall apply for types with seals.

OUTER RINGS TOLERANCE (μm)

TYPE	Cylindrical outer ring	Crowned outer ring
CF10,CF10-1,CF12	0/-9	0/-50
CF12-1,CF16,CF18,CF20-1	0/-11	0/-50
CF20,CF24,CF24-1,CF30	0/-13	0/-50
CF30-1,CF30-2	0/-15	0/-50

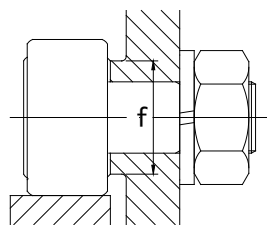
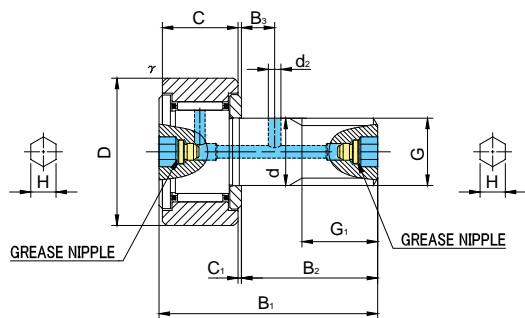

Prepacked Grease

						Basic dynamic load rating	Basic static load rating	Largest permissible load	Limiting speed *	Track load capacity		Max tightening torque	Mass
B3	C1	d2	H	r_s min	f min	Cr N	Cor N	N	rpm	Cylindrical outer ring N	Crowned outer ring N	N·m	g (approx)
9	0.8	4	8	1	36	20 680	34 600	32 140	7 000	21 000	7 150	120	385
						33 120	64 480	32 140	3 500				
11	0.8	4	8	1	40	30 480	52 630	49 500	6 500	34 200	10 500	220	815
						46 550	92 020	49 500	3 000				
11	0.8	4	8	1	40	30 480	52 630	49 500	6 500	39 800	12 900	220	1 140
						46 550	92 020	49 500	3 000				
15	1	4	8	1	46	45 370	85 060	73 700	5 000	52 600	14 900	450	1 870
						67 620	144 060	73 700	2 200				
15	1	4	8	1	46	45 370	85 060	73 700	5 000	56 000	16 100	450	2 030
						67 620	144 060	73 700	2 200				
15	1	4	8	1	46	45 370	85 060	73 700	5 000	59 300	17 300	450	2 220
						67 620	144 060	73 700	2 200				

ACCESSORIES

TYPE		
All types	Installed	Attached



CAM FOLLOWERS

FULL COMPLEMENT DOUBLE ROW
HEXAGON SOCKET ON BOTH SIDES
GREASE NIPPLE INSTALLED

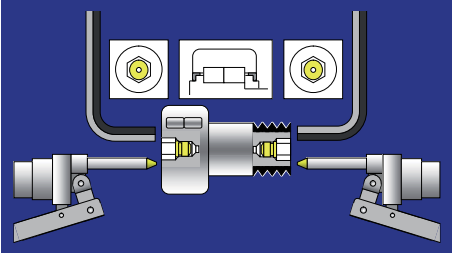

NUCF..AB

NUCF TYPE

Stud diameter (mm)	Designation	Dimensions (mm)											
		Cylindrical outer ring	Crowned outer ring R500(NUCF16~NUCF18) R1000(NUCF20≤)	D		C	d	G	G1	B1	B2	B3	C1
h7 tolerance	Without seals	With seals											
16	0 -0.018	NUCF16AB	NUCF16RAB	35	18	16	M16x1.5	17	52	32.5	7.8	0.8	
18	0 -0.018	NUCF18AB	NUCF18RAB	40	20	18	M18x1.5	19	58	36.5	8	0.8	
20	0 -0.021	NUCF20AB	NUCF20RAB	52	24	20	M20x1.5	21	66	40.5	9	0.8	
	0 -0.021	NUCF20-1AB	NUCF20-1RAB	47	24	20	M20x1.5	21	66	40.5	9	0.8	
24	0 -0.021	NUCF24AB	NUCF24RAB	62	28	24	M24x1.5	25	80	49.5	11	1.3	
	0 -0.021	NUCF24-1AB	NUCF24-1RAB	72	28	24	M24x1.5	25	80	49.5	11	1.3	
30	0 -0.021	NUCF30AB	NUCF30RAB	80	35	30	M30x1.5	32	100	63	15	1	
	0 -0.021	NUCF30-2AB	NUCF30-2RAB	90	35	30	M30x1.5	32	100	63	15	1	

OUTER RINGS TOLERANCE (μm)

TYPE	Cylindrical outer ring	Crowned outer ring
NUCF16,NUCF18,NUCF20-1	0/-11	0/-50
NUCF20,NUCF24,NUCF24-1,NUCF30	0/-13	0/-50
NUCF30-2	0/-15	0/-50

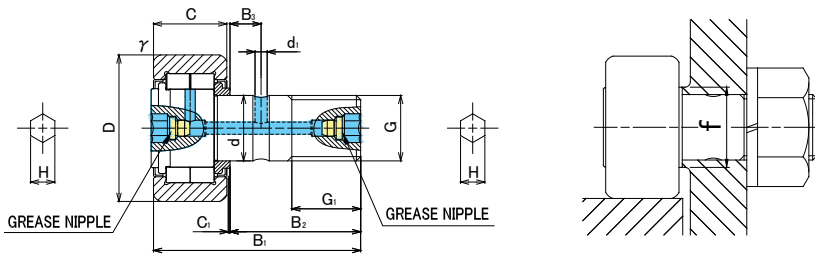

Prepacked Grease

				Basic dynamic load rating	Basic static load rating	Largest permissible load	Limiting speed	Track load capacity		Max tightening torque	Mass
D2	H	r/s min	f	Cr N	Cor N	N	rpm	Cylindrical outer ring N	Crowned outer ring N	N·m	g (approx)
3	6	0.6	20	23 400	27 200	11 900	5 200	11 200	3 140	58	167
3	6	1	22	25 200	30 900	22 200	4 700	14 400	3 720	87	248
4	8	1	31	43 000	58 100	25 700	3 300	23 200	8 230	120	461
4	8	1	27	38 900	48 900	25 300	3 800	21 000	7 150	120	390
4	8	1	38	57 600	74 300	35 000	2 800	32 000	10 500	220	789
4	8	1.1	44	63 300	87 500	53 700	2 300	37 200	12 900	220	1 020
4	8	1.1	47	94 800	135 700	73 700	2 100	52 600	14 900	450	1 630
4	8	1.1	47	94 800	135 700	73 700	2 100	59 300	17 300	450	1 990

ACCESSORIES

TYPE		
All types	Installed	Attached

NUCF



CAM FOLLOWERS

SCREWDRIVER SLOT HEAD

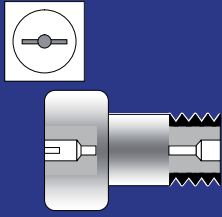

CF



CF.V

CF TYPE

Stud diameter (mm)	h7 tolerance	Designation				Dimensions (mm)							
		Cylindrical outer ring		Crowned outer ring R250(CF5) R500(CF6 ~ CF10-1)		D	C	d	G	G1	B1	B2	
		Without seals	With seals	Without seals	With seals								
5	0 -0.012	CF 5	CF 5UU	CF 5R	CF 5UUR	13	9	5	M5×0.8	7.5	23	13	
		CF 5V	CF 5VUU	CF 5VR	CF 5VUUR								
6	0 -0.012	CF 6	CF 6UU	CF 6R	CF 6UUR	16	11	6	M6×1	8	28	16	
		CF 6V	CF 6VUU	CF 6VR	CF 6VUUR								
8	0 -0.015	CF 8	CF 8UU	CF 8R	CF 8UUR	19	11	8	M8×1.25	10	32	20	
		CF 8V	CF 8VUU	CF 8VR	CF 8VUUR								
10	0 -0.015	CF10	CF10UU	CF10R	CF10UUR	22	12	10	M10×1.25	12	36	23	
		CF10V	CF10VUU	CF10VR	CF10VUUR								
10	0 -0.015	CF10-1	CF10-1UU	CF10-1R	CF10-1UUR	26	12	10	M10×1.25	12	36	23	
		CF10-1V	CF10-1VUU	CF10-1VR	CF10-1VUUR								
10	0 -0.015	CF10K	CF10UUK	CF10RK	CF10UURK	22	12	10	M10×1	12	36	23	
		CF10VK	CF10VUUK	CF10VRK	CF10VUURK								
10	0 -0.015	CF10-1K	CF10-1UUK	CF10-1RK	CF10-1UURK	26	12	10	M10×1	12	36	23	
		CF10-1VK	CF10-1VUUK	CF10-1VRK	CF10-1VUURK								

* Without seals, suitable for grease lubrication. In case of oil lubrication, up to 130% of this value shall be permissible, and 70% of this value shall apply for types with seals.

OUTER RINGS TOLERANCE

TYPE	Cylindrical outer ring	Crowned outer ring
CF5,CF6	0/-8	0/-50
CF8,CF10,CF10-1,CF12	0/-9	0/-50
CF12-1,CF16,CF18,CF20-1	0/-11	0/-50
CF20,CF24,CF24-1,CF30	0/-13	0/-50
CF30-1,CF30-2	0/-15	0/-50

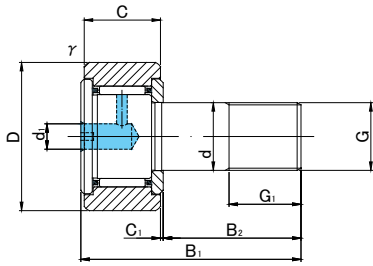

CF5(V)~CF10-1(V)

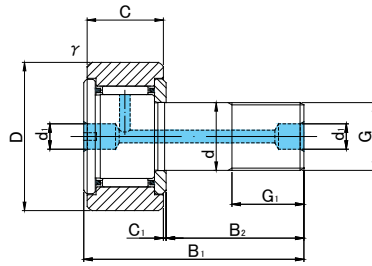

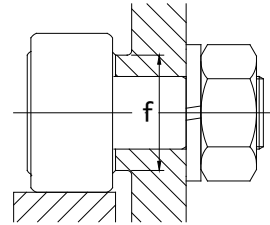

CF10(V)K~CF10-1(V)K



Prepacked Grease

B3	C1	d1	d2	fs min	f min	Basic dynamic load rating	Basic static load rating	Largest permissible load	Limiting speed *	Track load capacity		Max tightening torque	Mass
						Cr N	Cor N	N	rpm	Cylindrical outer ring N	Crowned outer ring N	N-m	g (approx)
—	0.5	3.1	—	0.3	9.7	3 140	2 770	1 420	29 000	2 250	780	2	10.5
						5 100	5 500	1 420	11 600				
—	0.6	4	—	0.3	11	3 630	3 630	2 110	25 000	3 430	1 080	3	18.5
						6 960	8 530	2 110	12 000				
—	0.6	4	—	0.3	13	4 310	4 710	4 710	20 000	4 020	1 370	8	28.5
						8 130	11 170	4 710	9 000				
—	0.6	4	—	0.3	15	5 390	6 860	6 860	17 000	4 700	1 670	15	45
						9 510	14 500	7 450	7 500				
—	0.6	4	—	0.3	15	5 390	6 860	6 860	17 000	5 490	2 060	15	60
						9 510	14 500	7 450	7 500				
—	0.6	4	—	0.3	15	5 390	6 860	6 860	17 000	4 700	1 670	15	45
						9 510	14 500	7 450	7 500				
—	0.6	4	—	0.3	15	5 390	6 860	6 860	17 000	5 490	2 060	15	60
						9 510	14 500	7 450	7 500				

ACCESSORIES

TYPE			
CF5	—	—	Attached
CF6/CF8/CF10/CF10-1	—	φ 4 Attached	Attached
CF12/CF12-1/CF16/CF18	φ 6 Attached	φ 6 Attached	Attached
CF20/CF20-1/CF24/CF24-1/CF30/CF30-1/CF30-2	φ 8 Attached	φ 8 Attached	Attached



CAM FOLLOWERS

SCREWDRIVER SLOT HEAD

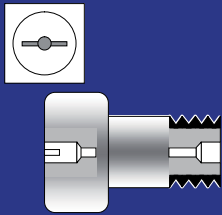

CF



CF.V

CF TYPE

Stud diameter (mm)	h7 tolerance	Designation				Dimensions (mm)							
		Cylindrical outer ring		Crowned outer ring R500(CF12 ~ CF18) R1000(CF20 ≤)		D	C	d	G	G1	B1	B2	
		Without seals	With seals	Without seals	With seals								
12	0 -0.018	CF12	CF12UU	CF12R	CF12UUR	30	14	12	M12×1.5	13	40	25	
		CF12V	CF12VUU	CF12VR	CF12VUUR								
12	0 -0.018	CF12-1	CF12-1UU	CF12-1R	CF12-1UUR	32	14	12	M12×1.5	13	40	25	
		CF12-1V	CF12-1VUU	CF12-1VR	CF12-1VUUR								
16	0 -0.018	CF16	CF16UU	CF16R	CF16UUR	35	18	16	M16×1.5	17	52	32.5	
		CF16V	CF16VUU	CF16VR	CF16VUUR								
18	0 -0.018	CF18	CF18UU	CF18R	CF18UUR	40	20	18	M18×1.5	19	58	36.5	
		CF18V	CF18VUU	CF18VR	CF18VUUR								
20	0 -0.021	CF20	CF20UU	CF20R	CF20UUR	52	24	20	M20×1.5	21	66	40.5	
		CF20V	CF20VUU	CF20VR	CF20VUUR								
20	0 -0.021	CF20-1	CF20-1UU	CF20-1R	CF20-1UUR	47	24	20	M20×1.5	21	66	40.5	
		CF20-1V	CF20-1VUU	CF20-1VR	CF20-1VUUR								
24	0 -0.021	CF24	CF24UU	CF24R	CF24UUR	62	29	24	M24×1.5	25	80	49.5	
		CF24V	CF24VUU	CF24VR	CF24VUUR								
24	0 -0.021	CF24-1	CF24-1UU	CF24-1R	CF24-1UUR	72	29	24	M24×1.5	25	80	49.5	
		CF24-1V	CF24-1VUU	CF24-1VR	CF24-1VUUR								
30	0 -0.021	CF30	CF30UU	CF30R	CF30UUR	80	35	30	M30×1.5	32	100	63	
		CF30V	CF30VUU	CF30VR	CF30VUUR								
30	0 -0.021	CF30-1	CF30-1UU	CF30-1R	CF30-1UUR	85	35	30	M30×1.5	32	100	63	
		CF30-1V	CF30-1VUU	CF30-1VR	CF30-1VUUR								
30	0 -0.021	CF30-2	CF30-2UU	CF30-2R	CF30-2UUR	90	35	30	M30×1.5	32	100	63	
		CF30-2V	CF30-2VUU	CF30-2VR	CF30-2VUUR								

* Without seals, suitable for grease lubrication. In case of oil lubrication, up to 130% of this value shall be permissible, and 70% of this value shall apply for types with seals.

OUTER RINGS TOLERANCE

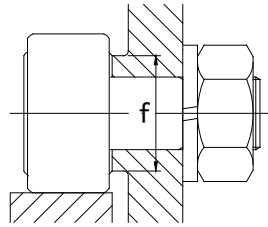
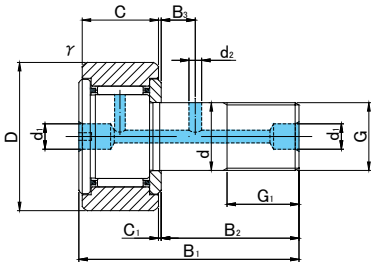

TYPE	Cylindrical outer ring	Crowned outer ring
CF5,CF6	0/-8	0/-50
CF8,CF10,CF10-1,CF12	0/-9	0/-50
CF12-1,CF16,CF18,CF20-1	0/-11	0/-50
CF20,CF24,CF24-1,CF30	0/-13	0/-50
CF30-1,CF30-2	0/-15	0/-50



Prepacked Grease

B3	C1	d1	d2	fs min	f min	Basic dynamic load rating	Basic static load rating	Largest permissible load	Limiting speed *	Track load capacity		Max tightening torque	Mass
						Cr N	Cor N	N	rpm	Cylindrical outer ring N	Crowned outer ring N	N-m	g (approx)
6	0.6	6	3	0.6	20	7 940	9 800	9 800	14 000	7 060	2 450	22	95
						13 430	19 700	11 270	6 000				
6	0.6	6	3	0.6	20	7 940	9 800	9 800	14 000	7 450	2 740	22	105
						13 430	19 700	11 270	6 000				
8	0.8	6	3	0.6	24	12 050	18 330	18 330	10 000	11 200	3 140	58	170
						20 680	37 630	19 800	4 500				
8	0.8	6	3	1	26	14 700	25 200	25 200	8 500	14 400	3 720	87	250
						25 280	51 350	26 560	3 500				
9	0.8	8	4	1	36	20 680	34 600	32 140	7 000	23 200	8 230	120	460
						33 120	64 480	32 140	3 500				
9	0.8	8	4	1	36	20 680	34 600	32 140	7 000	21 000	7 150	120	385
						33 120	64 480	32 140	3 500				
11	0.8	8	4	1	40	30 480	52 630	49 500	6 500	34 200	10 500	220	815
						46 550	92 020	49 500	3 000				
11	0.8	8	4	1	40	30 480	52 630	49 500	6 500	39 800	12 900	220	1 140
						46 550	92 020	49 500	3 000				
15	1	8	4	1	46	45 370	85 060	73 700	5 000	52 600	14 900	450	1 870
						67 620	144 060	73 700	2 200				
15	1	8	4	1	46	45 370	85 060	73 700	5 000	56 000	16 100	450	2 030
						67 620	144 060	73 700	2 200				
15	1	8	4	1	46	45 370	85 060	73 700	5 000	59 300	17 300	450	2 220
						67 620	144 060	73 700	2 200				

ACCESSORIES

TYPE			
CF5	—	—	Attached
CF6/CF8/CF10/CF10-1	—	φ 4 Attached	Attached
CF12/CF12-1/CF16/CF18	φ 6 Attached	φ 6 Attached	Attached
CF20/CF20-1/CF24/CF24-1/CF30/CF30-1/CF30-2	φ 8 Attached	φ 8 Attached	Attached



CAM FOLLOWERS

HEXAGON SOCKET ON THREAD SIDE
SCREWDRIVER SLOT HEAD

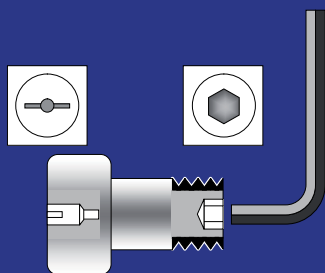

CF..B



CF..VB

CF..B TYPE

Stud diameter (mm)	h7 tolerance	Designation				Dimensions (mm)							
		Cylindrical outer ring		Crowned outer ring R500(CF12 ~ CF18) R1000(CF20 ≤)		D	C	d	G	G1	B1	B2	
		Without seals	With seals	Without seals	With seals								
12	0 -0.018	CF12B	CF12UUB	CF12RB	CF12UURB	30	14	12	M12×1.5	13	40	25	
		CF12VB	CF12VUUB	CF12VRB	CF12VUURB								
12	0 -0.018	CF12-1B	CF12-1UUB	CF12-1RB	CF12-1UURB	32	14	12	M12×1.5	13	40	25	
		CF12-1VB	CF12-1VUUB	CF12-1VRB	CF12-1VUURB								
16	0 -0.018	CF16B	CF16UUB	CF16RB	CF16UURB	35	18	16	M16×1.5	17	52	32.5	
		CF16VB	CF16VUUB	CF16VRB	CF16VUURB								
18	0 -0.018	CF18B	CF18UUB	CF18RB	CF18UURB	40	20	18	M18×1.5	19	58	36.5	
		CF18VB	CF18VUUB	CF18VRB	CF18VUURB								
20	0 -0.021	CF20B	CF20UUB	CF20RB	CF20UURB	52	24	20	M20×1.5	21	66	40.5	
		CF20VB	CF20VUUB	CF20VRB	CF20VUURB								
20	0 -0.021	CF20-1B	CF20-1UUB	CF20-1RB	CF20-1UURB	47	24	20	M20×1.5	21	66	40.5	
		CF20-1VB	CF20-1VUUB	CF20-1VRB	CF20-1VUURB								
24	0 -0.021	CF24B	CF24UUB	CF24RB	CF24UURB	62	29	24	M24×1.5	25	80	49.5	
		CF24VB	CF24VUUB	CF24VRB	CF24VUURB								
24	0 -0.021	CF24-1B	CF24-1UUB	CF24-1RB	CF24-1UURB	72	29	24	M24×1.5	25	80	49.5	
		CF24-1VB	CF24-1VUUB	CF24-1VRB	CF24-1VUURB								
30	0 -0.021	CF30B	CF30UUB	CF30RB	CF30UURB	80	35	30	M30×1.5	32	100	63	
		CF30VB	CF30VUUB	CF30VRB	CF30VUURB								
30	0 -0.021	CF30-1B	CF30-1UUB	CF30-1RB	CF30-1UURB	85	35	30	M30×1.5	32	100	63	
		CF30-1VB	CF30-1VUUB	CF30-1VRB	CF30-1VUURB								
30	0 -0.021	CF30-2B	CF30-2UUB	CF30-2RB	CF30-2UURB	90	35	30	M30×1.5	32	100	63	
		CF30-2VB	CF30-2VUUB	CF30-2VRB	CF30-2VUURB								

* Without seals, suitable for grease lubrication. In case of oil lubrication, up to 130% of this value shall be permissible, and 70% of this value shall apply for types with seals.

OUTER RINGS TOLERANCE (μm)

TYPE	Cylindrical outer ring	Crowned outer ring
CF12	0/-9	0/-50
CF12-1,CF16,CF18,CF20-1	0/-11	0/-50
CF20,CF24,CF24-1,CF30	0/-13	0/-50
CF30-1,CF30-2	0/-15	0/-50

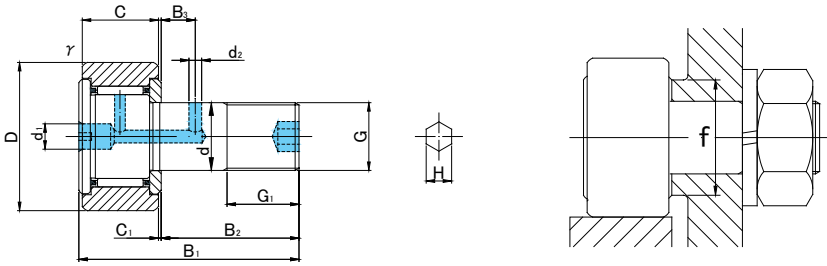

Prepacked Grease

								Basic dynamic load rating	Basic static load rating	Largest permissible load	Limiting speed *	Track load capacity		Max tightening torque	Mass
B3	C1	d1	d2	H	rs min	f min	Cr N	Cor N	N	rpm	Cylindrical outer ring N	Crowned outer ring N	N·m	g (approx)	
6	0.6	6	3	6	0.6	20	7 940	9 800	9 800	14 000	7 060	2 450	22	95	
							13 430	19 700	11 270	6 000					
6	0.6	6	3	6	0.6	20	7 940	9 800	9 800	14 000	7 450	2 740	22	105	
							13 430	19 700	11 270	6 000					
8	0.8	6	3	6	0.6	24	12 050	18 330	18 330	10 000	11 200	3 140	58	170	
							20 680	37 630	19 800	4 500					
8	0.8	6	3	6	1	26	14 700	25 200	25 200	8 500	14 400	3 720	87	250	
							25 280	51 350	26 560	3 500					
9	0.8	8	4	8	1	36	20 680	34 600	32 140	7 000	23 200	8 230	120	460	
							33 120	64 480	32 140	3 500					
9	0.8	8	4	8	1	36	20 680	34 600	32 140	7 000	21 000	7 150	120	385	
							33 120	64 480	32 140	3 500					
11	0.8	8	4	8	1	40	30 480	52 630	49 500	6 500	34 200	10 500	220	815	
							46 550	92 020	49 500	3 000					
11	0.8	8	4	8	1	40	30 480	52 630	49 500	6 500	39 800	12 900	220	1 140	
							46 550	92 020	49 500	3 000					
15	1	8	4	8	1	46	45 370	85 060	73 700	5 000	52 600	14 900	450	1 870	
							67 620	144 060	73 700	2 200					
15	1	8	4	8	1	46	45 370	85 060	73 700	5 000	56 000	16 100	450	2 030	
							67 620	144 060	73 700	2 200					
15	1	8	4	8	1	46	45 370	85 060	73 700	5 000	59 300	17 300	450	2 220	
							67 620	144 060	73 700	2 200					

ACCESSORIES

TYPE			
CF3/CF4/CF5	—	—	Attached
CF6/CF8/CF10/CF10-1	—	—	Attached
CF12/CF12-1/CF16/CF18	φ 6 Attached	φ 6 Attached	Attached
CF20/CF20-1/CF24/CF24-1/CF30/CF30-1/CF30-2	φ 8 Attached	φ 8 Attached	Attached



CAM FOLLOWERS

SOLID ECCENTRIC TYPE
HEXAGON SOCKET ON STUD HEAD

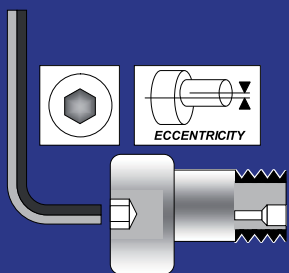

CFH..A

CFH..VA

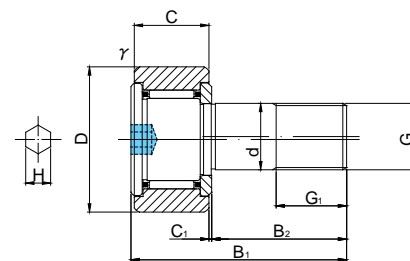

CFH5(V)A~CFH10-1(V)A

CFH..A TYPE

Stud diameter (mm)	h7 tolerance	Designation				Dimensions (mm)						
		Cylindrical outer ring		Crowned outer ring R250(CF5) R500(CF6 ~ CF12-1)		D	C	d	G	G1	B1	B2
		Without seals	With seals	Without seals	With seals							
5	0 -0.012	CFH 5A	CFH 5UUA	CFH 5RA	CFH 5UURA	13	9	5	M5×0.8	7.5	23	13
		CFH 5VA	CFH 5VUUA	CFH 5VRA	CFH 5VUURA							
6	0 -0.012	CFH 6A	CFH 6UUA	CFH 6RA	CFH 6UURA	16	11	6	M6×1	8	28	16
		CFH 6VA	CFH 6VUUA	CFH 6VRA	CFH 6VUURA							
8	0 -0.015	CFH 8A	CFH 8UUA	CFH 8RA	CFH 8UURA	19	11	8	M8×1.25	10	32	20
		CFH 8VA	CFH 8VUUA	CFH 8VRA	CFH 8VUURA							
10	0 -0.015	CFH10A	CFH10UUA	CFH10RA	CFH10UURA	22	12	10	M10×1.25	12	36	23
		CFH10VA	CFH10VUUA	CFH10VRA	CFH10VUURA							
10	0 -0.015	CFH10-1A	CFH10-1UUA	CFH10-1RA	CFH10-1UURA	26	12	10	M10×1.25	12	36	23
		CFH10-1VA	CFH10-1VUUA	CFH10-1VRA	CFH10-1VUURA							
12	0 -0.018	CFH12A	CFH12UUA	CFH12RA	CFH12UURA	30	14	12	M12×1.5	13	40	25
		CFH12VA	CFH12VUUA	CFH12VRA	CFH12VUURA							
12	0 -0.018	CFH12-1A	CFH12-1UUA	CFH12-1RA	CFH12-1UURA	32	14	12	M12×1.5	13	40	25
		CFH12-1VA	CFH12-1VUUA	CFH12-1VRA	CFH12-1VUURA							

* Without seals, suitable for grease lubrication. In case of oil lubrication, up to 130% of this value shall be permissible, and 70% of this value shall apply for types with seals.

OUTER RINGS TOLERANCE (μm)

TYPE	Cylindrical outer ring	Crowned outer ring
CF5,CF6	0/-8	0/-50
CF8,CF10,CF10-1,CF12	0/-9	0/-50
CF12-1,CF16,CF18,CF20-1	0/-11	0/-50
CF20,CF24,CF24-1,CF30	0/-13	0/-50
CF30-1,CF30-2	0/-15	0/-50



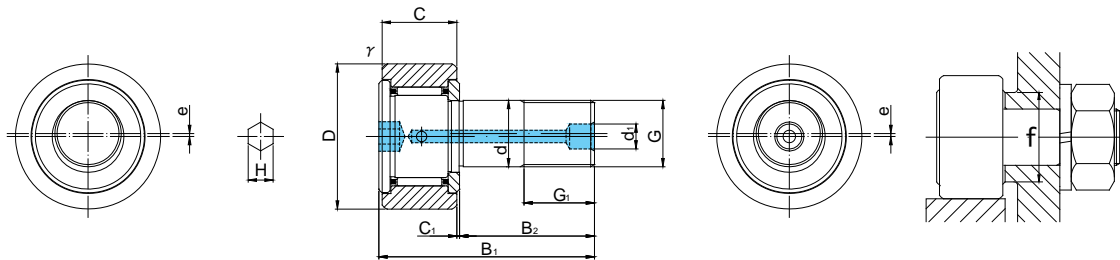



CFH12(V)A~CFH12-1(V)A

Prepacked Grease

C1	d1	H	fs min	e	f min	Basic load rating		Largest permissible load	Limiting speed *	Track load capacity		Max tightening torque	Mass
						Cr N	Cor N			Cylindrical outer ring N	Crowned outer ring N		
0.5	—	3	0.3	0.2	9.7	3 140	2 770	1 420	29 000	2 250	780	2	10.5
						5 100	5 500	1 420	11 600				
0.6	—	3	0.3	0.25	11	3 630	3 630	2 110	25 000	3 430	1 080	3	18.5
						6 960	8 530	2 110	12 000				
0.6	—	4	0.3	0.25	13	4 310	4 710	4 710	20 000	4 020	1 370	8	28.5
						8 130	11 170	4 710	9 000				
0.6	—	5	0.3	0.3	15	5 390	6 860	6 860	17 000	4 700	1 670	15	45
						9 510	14 500	7 450	7 500				
0.6	—	5	0.3	0.3	15	5 390	6 860	6 860	17 000	5 490	2 060	15	60
						9 510	14 500	7 450	7 500				
0.6	6	6	0.6	0.4	20	7 940	9 800	9 800	14 000	7 060	2 450	22	95
						13 430	19 700	11 270	6 000				
0.6	6	6	0.6	0.4	20	7 940	9 800	9 800	14 000	7 450	2 740	22	105
						13 430	19 700	11 270	6 000				

ACCESSORIES

TYPE			
CF5	—	—	Attached
CF6/CF8/CF10/CF10-1	—	—	Attached
CF12/CF12-1/CF16/CF18	φ 6 Attached	φ 6 Attached	Attached
CF20/CF20-1/CF24/CF24-1/CF30/CF30-1/CF30-2	φ 8 Attached	φ 8 Attached	Attached

CFH..A



CAM FOLLOWERS

SOLID ECCENTRIC TYPE
HEXAGON SOCKET ON STUD HEAD

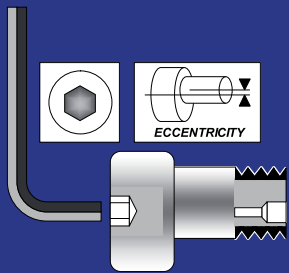

CFH..A



CFH..VA

CFH..A TYPE

Stud diameter (mm)	h7 tolerance	Designation				Dimensions (mm)						
		Cylindrical outer ring		Crowned outer ring R250(CF5) R500(CF6 ~ CF18) R1000(CF20 ≤)		D	C	d	G	G1	B1	B2
		Without seals	With seals	Without seals	With seals							
16	0 -0.018	CFH16A	CFH16UUA	CFH16RA	CFH16UURA	35	18	16	M16×1.5	17	52	32.5
		CFH16VA	CFH16VUUA	CFH16VRA	CFH16VUURA							
18	0 -0.018	CFH18A	CFH18UUA	CFH18RA	CFH18UURA	40	20	18	M18×1.5	19	58	36.5
		CFH18VA	CFH18VUUA	CFH18VRA	CFH18VUURA							
20	0 -0.021	CFH20A	CFH20UUA	CFH20RA	CFH20UURA	52	24	20	M20×1.5	21	66	40.5
		CFH20VA	CFH20VUUA	CFH20VRA	CFH20VUURA							
20	0 -0.021	CFH20-1A	CFH20-1UUA	CFH20-1RA	CFH20-1UURA	47	24	20	M20×1.5	21	66	40.5
		CFH20-1VA	CFH20-1VUUA	CFH20-1VRA	CFH20-1VUURA							
24	0 -0.021	CFH24A	CFH24UUA	CFH24RA	CFH24UURA	62	29	24	M24×1.5	25	80	49.5
		CFH24VA	CFH24VUUA	CFH24VRA	CFH24VUURA							
24	0 -0.021	CFH24-1A	CFH24-1UUA	CFH24-1RA	CFH24-1UURA	72	29	24	M24×1.5	25	80	49.5
		CFH24-1VA	CFH24-1VUUA	CFH24-1VRA	CFH24-1VUURA							
30	0 -0.021	CFH30A	CFH30UUA	CFH30RA	CFH30UURA	80	35	30	M30×1.5	32	100	63
		CFH30VA	CFH30VUUA	CFH30VRA	CFH30VUURA							
30	0 -0.021	CFH30-1A	CFH30-1UUA	CFH30-1RA	CFH30-1UURA	85	35	30	M30×1.5	32	100	63
		CFH30-1VA	CFH30-1VUUA	CFH30-1VRA	CFH30-1VUURA							
30	0 -0.021	CFH30-2A	CFH30-2UUA	CFH30-2RA	CFH30-2UURA	90	35	30	M30×1.5	32	100	63
		CFH30-2VA	CFH30-2VUUA	CFH30-2VRA	CFH30-2VUURA							

* Without seals, suitable for grease lubrication. In case of oil lubrication, up to 130% of this value shall be permissible, and 70% of this value shall apply for types with seals.

OUTER RINGS TOLERANCE (μm)

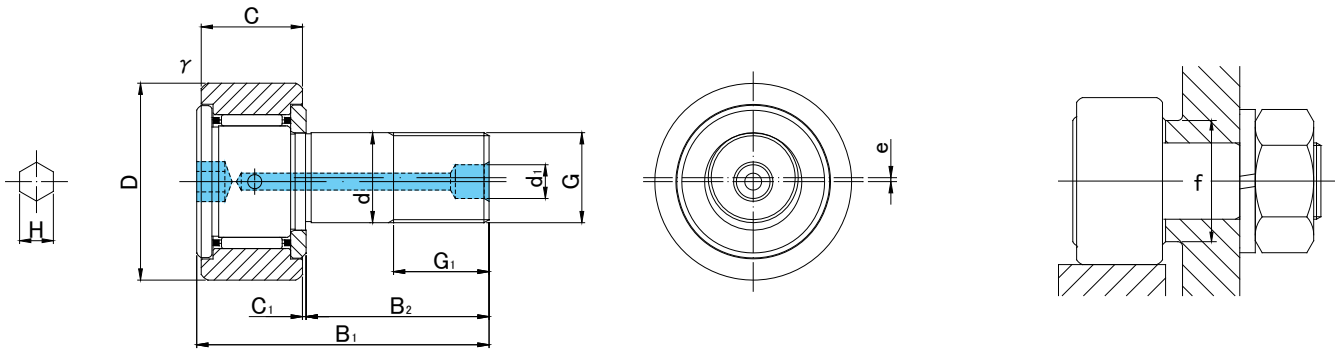

TYPE	Cylindrical outer ring	Crowned outer ring
CF5,CF6	0/-8	0/-50
CF8,CF10,CF10-1,CF12	0/-9	0/-50
CF12-1,CF16,CF18,CF20-1	0/-11	0/-50
CF20,CF24,CF24-1,CF30	0/-13	0/-50
CF30-1,CF30-2	0/-15	0/-50



Prepacked Grease

C1	d1	H	fs min	e	f min	Basic load ratings		Largest permissible load	Limiting speed *	Track load capacity		Max tightening torque	Mass
						Cr N	Cor N			Cylindrical outer ring N	Crowned outer ring N		
0.8	6	6	0.6	0.5	24	12 050	18 330	18 330	10 000	11 200	3 140	58	170
						20 680	37 630	19 800	4 500				
0.8	6	6	1	0.6	26	14 700	25 200	25 200	8 500	14 400	3 720	87	250
						25 280	51 350	26 560	3 500				
0.8	8	8	1	0.7	36	20 680	34 600	32 140	7 000	23 200	8 230	120	460
						33 120	64 480	32 140	3 500				
0.8	8	8	1	0.7	36	20 680	34 600	32 140	7 000	21 000	7 150	120	385
						33 120	64 480	32 140	3 500				
0.8	8	8	1	0.8	40	30 480	52 630	49 500	6 500	34 200	10 500	220	815
						46 550	92 020	49 500	3 000				
0.8	8	8	1	0.8	40	30 480	52 630	49 500	6 500	39 800	12 900	220	1 140
						46 550	92 020	49 500	3 000				
1	8	8	1	1	46	45 370	85 060	73 700	5 000	52 600	14 900	450	1 870
						67 620	144 060	73 700	2 200				
1	8	8	1	1	46	45 370	85 060	73 700	5 000	56 000	16 100	450	2 030
						67 620	144 060	73 700	2 200				
1	8	8	1	1	46	45 370	85 060	73 700	5 000	59 300	17 300	450	2 220
						67 620	144 060	73 700	2 200				

ACCESSORIES

TYPE			
CF5	—	—	Attached
CF6/CF8/CF10/CF10-1	—	—	Attached
CF12/CF12-1/CF16/CF18	φ 6 Attached	φ 6 Attached	Attached
CF20/CF20-1/CF24/CF24-1/CF30/CF30-1/CF30-2	φ 8 Attached	φ 8 Attached	Attached



CAM FOLLOWERS

SOLID ECCENTRIC TYPE
HEXAGON SOCKET ON BOTH SIDES
GREASE NIPPLE INSTALLED

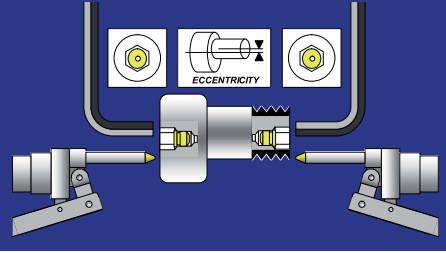

CFH..AB



CFH..VAB

CFH..AB TYPE

Stud diameter (mm)	Designation	Dimensions (mm)																			
		Cylindrical outer ring				Crowned outer ring R500(CF10 ~ CF18) R1000(CF20 ≤)				D		C		d		G		G1		B1	
h7 tolerance	Without seals	With seals	Without seals	With seals	D	C	d	G	G1	B1	B2										
12	CFH12AB	CFH12UUAB	CFH12RAB	CFH12UURAB	30	14	12	M12×1.5	13	40	25										
	CFH12VAB	CFH12VUUAB	CFH12VRAB	CFH12VUURAB																	
12	CFH12-1AB	CFH12-1UUAB	CFH12-1RAB	CFH12-1UURAB	32	14	12	M12×1.5	13	40	25										
	CFH12-1VAB	CFH12-1VUUAB	CFH12-1VRAB	CFH12-1VUURAB																	
16	CFH16AB	CFH16UUAB	CFH16RAB	CFH16UURAB	35	18	16	M16×1.5	17	52	32.5										
	CFH16VAB	CFH16VUUAB	CFH16VRAB	CFH16VUURAB																	
18	CFH18AB	CFH18UUAB	CFH18RAB	CFH18UURAB	40	20	18	M18×1.5	19	58	36.5										
	CFH18VAB	CFH18VUUAB	CFH18VRAB	CFH18VUURAB																	
20	CFH20AB	CFH20UUAB	CFH20RAB	CFH20UURAB	52	24	20	M20×1.5	21	66	40.5										
	CFH20VAB	CFH20VUUAB	CFH20VRAB	CFH20VUURAB																	
20	CFH20-1AB	CFH20-1UUAB	CFH20-1RAB	CFH20-1UURAB	47	24	20	M20×1.5	21	66	40.5										
	CFH20-1VAB	CFH20-1VUUAB	CFH20-1VRAB	CFH20-1VUURAB																	

CFH..AB TYPE has oil holes (grease nipple) which are prepared in the stud head and thread side, also an oil hole is prepared outer surface of stud.

* Without seals, suitable for grease lubrication. In case of oil lubrication, up to 130% of this value shall be permissible, and 70% of this value shall apply for types with seals.

OUTER RINGS TOLERANCE (μm)

TYPE	Cylindrical outer ring	Crowned outer ring
CF12	0/-9	0/-50
CF12-1,CF16,CF18,CF20-1	0/-11	0/-50
CF20,CF24,CF24-1,CF30	0/-13	0/-50
CF30-1,CF30-2	0/-15	0/-50

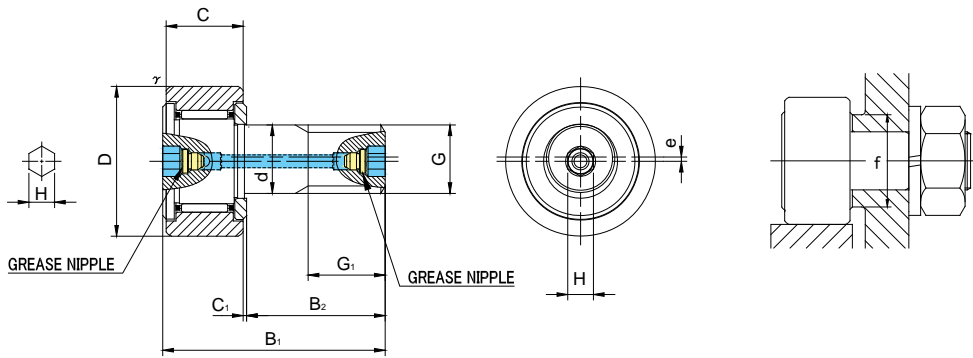

Prepacked Grease

					Basic dynamic load rating	Basic static load rating	Largest permissible load	Limiting speed *	Track load capacity		Max tightening torque	Mass
C1	H	f_s min	e	f min	Cr N	Cor N	N	rpm	Cylindrical outer ring N	Crowned outer ring N	N-m	g (approx)
0.6	6	0.6	0.4	20	7 940	9 800	9 800	14 000	7 060	2 450	22	95
					13 430	19 700	11 270	6 000				
0.6	6	0.6	0.4	20	7 940	9 800	9 800	14 000	7 450	2 740	22	105
					13 430	19 700	11 270	6 000				
0.8	6	0.6	0.5	24	12 050	18 330	18 330	10 000	11 200	3 140	58	170
					20 680	37 630	19 800	4 500				
0.8	6	1	0.6	26	14 700	25 200	25 200	8 500	14 400	3 720	87	250
					25 280	51 350	26 560	3 500				
0.8	8	1	0.7	36	20 680	34 600	32 140	7 000	23 200	8 230	120	460
					33 120	64 480	32 140	3 500				
0.8	8	1	0.7	36	20 680	34 600	32 140	7 000	21 000	7 150	120	385
					33 120	64 480	32 140	3 500				

ACCESSORIES

TYPE		
All types	Installed	Attached



CAM FOLLOWERS

SOLID ECCENTRIC TYPE
HEXAGON SOCKET ON BOTH SIDES
GREASE NIPPLE INSTALLED

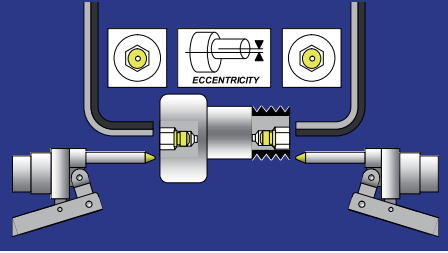

CFH..AB



CFH..VAB

CFH..AB TYPE

Stud diameter (mm)	Designation	Dimensions (mm)										
		Cylindrical outer ring				Crowned outer ring R1000(CF24 ≤)				Other dimensions		
h7 tolerance	Without seals	With seals	Without seals	With seals	D	C	d	G	G1	B1	B2	
24	CFH24AB	CFH24UUAB	CFH24RAB	CFH24UURAB	62	29	24	M24×1.5	25	80	49.5	
	CFH24VAB	CFH24VUUAB	CFH24VRAB	CFH24VUURAB								
24	CFH24-1AB	CFH24-1UUAB	CFH24-1RAB	CFH24-1UURAB	72	29	24	M24×1.5	25	80	49.5	
	CFH24-1VAB	CFH24-1VUUAB	CFH24-1VRAB	CFH24-1VUURAB								
30	CFH30AB	CFH30UUAB	CFH30RAB	CFH30UURAB	80	35	30	M30×1.5	32	100	63	
	CFH30VAB	CFH30VUUAB	CFH30VRAB	CFH30VUURAB								
30	CFH30-1AB	CFH30-1UUAB	CFH30-1RAB	CFH30-1UURAB	85	35	30	M30×1.5	32	100	63	
	CFH30-1VAB	CFH30-1VUUAB	CFH30-1VRAB	CFH30-1VUURAB								
30	CFH30-2AB	CFH30-2UUAB	CFH30-2RAB	CFH30-2UURAB	90	35	30	M30×1.5	32	100	63	
	CFH30-2VAB	CFH30-2VUUAB	CFH30-2VRAB	CFH30-2VUURAB								

CFH..AB TYPE has oil holes (grease nipple) which are prepared in the stud head and thread side, also an oil hole is prepared outer surface of stud.

* Without seals, suitable for grease lubrication. In case of oil lubrication, up to 130% of this value shall be permissible, and 70% of this value shall apply for types with seals.

OUTER RINGS TOLERANCE (μm)

TYPE	Cylindrical outer ring	Crowned outer ring
CF12	0/-9	0/-50
CF12-1,CF16,CF18,CF20-1	0/-11	0/-50
CF20,CF24,CF24-1,CF30	0/-13	0/-50
CF30-1,CF30-2	0/-15	0/-50

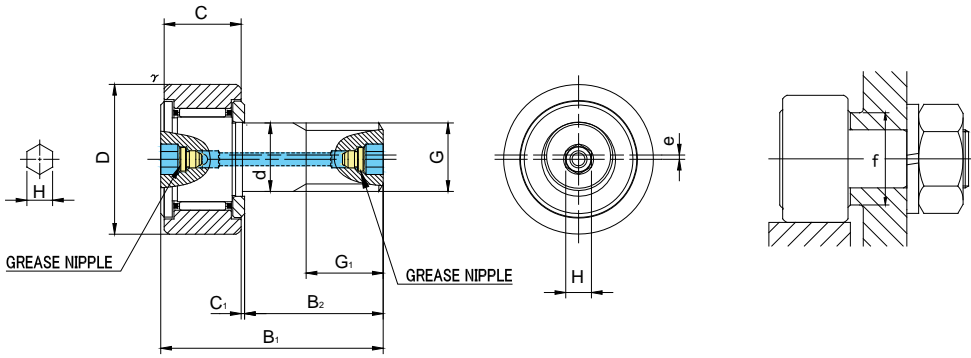

Prepacked Grease

					Basic dynamic load rating	Basic static load rating	Largest permissible load	Limiting speed *	Track load capacity		Max tightening torque	Mass
C1	H	f_s min	e	f min	Cr N	Cor N	N	rpm	Cylindrical outer ring N	Crowned outer ring N	N-m	g (approx)
0.8	8	1	0.8	40	30 480	52 630	49 500	6 500	34 200	10 500	220	815
					46 550	92 020	49 500	3 000				
0.8	8	1	0.8	40	30 480	52 630	49 500	6 500	39 800	12 900	220	1 140
					46 550	92 020	49 500	3 000				
1	8	1	1	46	45 370	85 060	73 700	5 000	52 600	14 900	450	1 870
					67 620	144 060	73 700	2 200				
1	8	1	1	46	45 370	85 060	73 700	5 000	56 000	16 100	450	2 030
					67 620	144 060	73 700	2 200				
1	8	1	1	46	45 370	85 060	73 700	5 000	59 300	17 300	450	2 220
					67 620	144 060	73 700	2 200				

ACCESSORIES

TYPE		
All types	Installed	Attached



CAM FOLLOWERS

SOLID ECCENTRIC TYPE
SCREWDRIVER SLOT HEAD

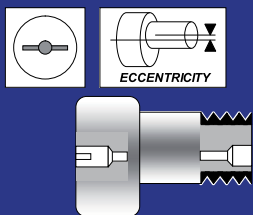

CFH



CFH.V

CFH TYPE

Stud diameter (mm)	h7 tolerance	Designation				Dimensions (mm)							
		Cylindrical outer ring		Crowned outer ring R250(CF5) R500 (CF6 ~ CF16)		D	C	d	G	G1	B1	B2	
		Without seals	With seals	Without seals	With seals								
5	0 -0.012	CFH 5	CFH 5UU	CFH 5R	CFH 5UUR	13	9	5	M5×0.8	7.5	23	13	
		CFH 5V	CFH 5VUU	CFH 5VR	CFH 5VUUR								
6	0 -0.012	CFH 6	CFH 6UU	CFH 6R	CFH 6UUR	16	11	6	M6×1	8	28	16	
		CFH 6V	CFH 6VUU	CFH 6VR	CFH 6VUUR								
8	0 -0.015	CFH 8	CFH 8UU	CFH 8R	CFH 8UUR	19	11	8	M8×1.25	10	32	20	
		CFH 8V	CFH 8VUU	CFH 8VR	CFH 8VUUR								
10	0 -0.015	CFH10	CFH10UU	CFH10R	CFH10UUR	22	12	10	M10×1.25	12	36	23	
		CFH10V	CFH10VUU	CFH10VR	CFH10VUUR								
10	0 -0.015	CFH10-1	CFH10-1UU	CFH10-1R	CFH10-1UUR	26	12	10	M10×1.25	12	36	23	
		CFH10-1V	CFH10-1VUU	CFH10-1VR	CFH10-1VUUR								
12	0 -0.018	CFH12	CFH12UU	CFH12R	CFH12UUR	30	14	12	M12×1.5	13	40	25	
		CFH12V	CFH12VUU	CFH12VR	CFH12VUUR								
12	0 -0.018	CFH12-1	CFH12-1UU	CFH12-1R	CFH12-1UUR	32	14	12	M12×1.5	13	40	25	
		CFH12-1V	CFH12-1VUU	CFH12-1VR	CFH12-1VUUR								
16	0 -0.018	CFH16	CFH16UU	CFH16R	CFH16UUR	35	18	16	M16×1.5	17	52	32.5	
		CFH16V	CFH16VUU	CFH16VR	CFH16VUUR								

* Without seals, suitable for grease lubrication. In case of oil lubrication, up to 130% of this value shall be permissible, and 70% of this value shall apply for types with seals.

OUTER RINGS TOLERANCE (μm)

TYPE	Cylindrical outer ring	Crowned outer ring
CF5,CF6	0/-8	0/-50
CF8,CF10,CF10-1,CF12	0/-9	0/-50
CF12-1,CF16,CF18,CF20-1	0/-11	0/-50
CF20,CF24,CF24-1,CF30	0/-13	0/-50
CF30-1,CF30-2	0/-15	0/-50

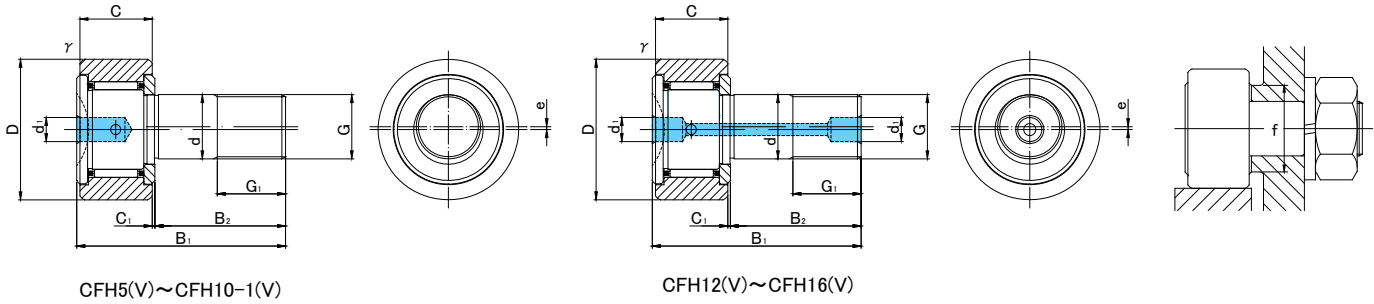

Prepacked Grease

					Basic dynamic load rating	Basic static load rating	Largest permissible load	Limiting speed *	Track load capacity		Max tightening torque	Mass
C1	d1	<i>r</i> s min	e	f min	Cr N	Cor N	N	rpm	Cylindrical outer ring N	Crowned outer ring N	N·m	g (approx)
0.5	3.1	0.3	0.2	9.7	3 140	2 770	1 420	29 000	2 250	780	2	10.5
					5,100	5,500	1 420	11,600				
0.6	4	0.3	0.25	11	3 630	3 630	2 110	25 000	3 430	1 080	3	18.5
					6 960	8 530	2 110	12 000				
0.6	4	0.3	0.25	13	4 310	4 710	4 710	20 000	4 020	1 370	8	28.5
					8 130	11 170	4 710	9 000				
0.6	4	0.3	0.3	15	5 390	6 860	6 860	17 000	4 700	1 670	15	45
					9 510	14 500	7 450	7 500				
0.6	4	0.3	0.3	15	5 390	6 860	6 860	17 000	5 490	2 060	15	60
					9 510	14 500	7 450	7 500				
0.6	6	0.6	0.4	20	7 940	9 800	9 800	14 000	7 060	2 450	22	95
					13 430	19 700	11 270	6 000				
0.6	6	0.6	0.4	20	7 940	9 800	9 800	14 000	7 450	2 740	22	105
					13 430	19 700	11 270	6 000				
0.8	6	0.6	0.5	24	12 050	18 330	18 330	10 000	11 200	3 140	58	170
					20 680	37 630	19 800	4 500				

ACCESSORIES

TYPE			
	STOP PLUG	RESIN PLUG	NUT
CF5	—	—	Attached
CF6/CF8/CF10/CF10-1	—	φ 4 Attached	Attached
CF12/CF12-1/CF16/CF18	φ 6 Attached	φ 6 Attached	Attached
CF20/CF20-1/CF24/CF24-1/CF30/CF30-1/CF30-2	φ 8 Attached	φ 8 Attached	Attached



CAM FOLLOWERS

SOLID ECCENTRIC TYPE
SCREWDRIVER SLOT HEAD

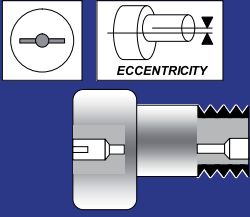

CFH



CFH.V

CFH TYPE

Stud diameter (mm)	h7 tolerance	Designation				Dimensions (mm)							
		Cylindrical outer ring		Crowned outer ring R500(CF18) R1000(CF20 ≤)		D	C	d	G	G1	B1	B2	
		Without seals	With seals	Without seals	With seals								
18	0 -0.018	CFH18	CFH18UU	CFH18R	CFH18UUR	40	20	18	M18×1.5	19	58	36.5	
		CFH18V	CFH18VUU	CFH18VR	CFH18VUUR								
20	0 -0.021	CFH20	CFH20UU	CFH20R	CFH20UUR	52	24	20	M20×1.5	21	66	40.5	
		CFH20V	CFH20VUU	CFH20VR	CFH20VUUR								
20	0 -0.021	CFH20-1	CFH20-1UU	CFH20-1R	CFH20-1UUR	47	24	20	M20×1.5	21	66	40.5	
		CFH20-1V	CFH20-1VUU	CFH20-1VR	CFH20-1VUUR								
24	0 -0.021	CFH24	CFH24UU	CFH24R	CFH24UUR	62	29	24	M24×1.5	25	80	49.5	
		CFH24V	CFH24VUU	CFH24VR	CFH24VUUR								
24	0 -0.021	CFH24-1	CFH24-1UU	CFH24-1R	CFH24-1UUR	72	29	24	M24×1.5	25	80	49.5	
		CFH24-1V	CFH24-1VUU	CFH24-1VR	CFH24-1VUUR								
30	0 -0.021	CFH30	CFH30UU	CFH30R	CFH30UUR	80	35	30	M30×1.5	32	100	63	
		CFH30V	CFH30VUU	CFH30VR	CFH30VUUR								
30	0 -0.021	CFH30-1	CFH30-1UU	CFH30-1R	CFH30-1UUR	85	35	30	M30×1.5	32	100	63	
		CFH30-1V	CFH30-1VUU	CFH30-1VR	CFH30-1VUUR								
30	0 -0.021	CFH30-2	CFH30-2UU	CFH30-2R	CFH30-2UUR	90	35	30	M30×1.5	32	100	63	
		CFH30-2V	CFH30-2VUU	CFH30-2VR	CFH30-2VUUR								

* Without seals, suitable for grease lubrication. In case of oil lubrication, up to 130% of this value shall be permissible, and 70% of this value shall apply for types with seals.

OUTER RINGS TOLERANCE (μm)

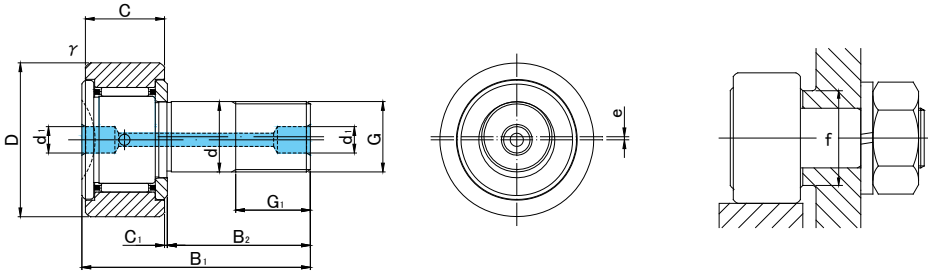

TYPE	Cylindrical outer ring	Crowned outer ring
CF5,CF6	0/-8	0/-50
CF8,CF10,CF10-1,CF12	0/-9	0/-50
CF12-1,CF16,CF18,CF20-1	0/-11	0/-50
CF20,CF24,CF24-1,CF30	0/-13	0/-50
CF30-1,CF30-2	0/-15	0/-50



Prepacked Grease

C1	d1	fs min	e	f min	Basic dynamic load rating	Basic static load rating	Largest permissible load	Limiting speed *	Track load capacity		Max tightening torque	Mass
					Cr N	Cor N	N	rpm	Cylindrical outer ring N	Crowned outer ring N	N·m	g (approx)
0.8	6	1	0.6	26	14 700	25 200	25 200	8 500	14 400	3 720	87	250
					25 280	51 350	26 560	3 500				
0.8	8	1	0.7	36	20 680	34 600	32 140	7 000	23 200	8 230	120	460
					33 120	64 480	32 140	3 500				
0.8	8	1	0.7	36	20 680	34 600	32 140	7 000	21 000	7 150	120	385
					33 120	64 480	32 140	3 500				
0.8	8	1	0.8	40	30 480	52 630	49 500	6 500	34 200	10 500	220	815
					46 550	92 020	49 500	3 000				
0.8	8	1	0.8	40	30 480	52 630	49 500	6 500	39 800	12 900	220	1 140
					46 550	92 020	49 500	3 000				
1	8	1	1	46	45 370	85 060	73 700	5 000	52 600	14 900	450	1 870
					67 620	144 060	73 700	2 200				
1	8	1	1	46	45 370	85 060	73 700	5 000	56 000	16 100	450	2 030
					67 620	144 060	73 700	2 200				
1	8	1	1	46	45 370	85 060	73 700	5 000	59 300	17 300	450	2 220
					67 620	144 060	73 700	2 200				

ACCESSORIES

TYPE			
CF5	—	—	Attached
CF6/CF8/CF10/CF10-1	—	φ 4 Attached	Attached
CF12/CF12-1/CF16/CF18	φ 6 Attached	φ 6 Attached	Attached
CF20/CF20-1/CF24/CF24-1/CF30/CF30-1/CF30-2	φ 8 Attached	φ 8 Attached	Attached



CAM FOLLOWERS

SOLID ECCENTRIC TYPE
HEXAGON SOCKET ON THREAD SIDE
SCREWDRIVER SLOT HEAD

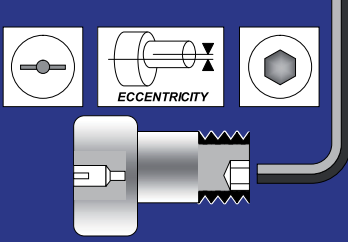

CFH..B



CFH..VB

CFH..B TYPE

Stud diameter (mm)	h7 tolerance	Designation				Dimensions (mm)						
		Cylindrical outer ring		Crowned outer ring R500(CF12 ~ CF18) R1000(CF20 ≤)		D	C	d	G	G1	B1	B2
		Without seals	With seals	Without seals	With seals							
12	0 -0.018	CFH12B	CFH12UUB	CFH12RB	CFH12URB	30	14	12	M12×1.5	13	40	25
		CFH12VB	CFH12VUUB	CFH12VRB	CFH12VURB							
12	0 -0.018	CFH12-1B	CFH12-1UUB	CFH12-1RB	CFH12-1URB	32	14	12	M12×1.5	13	40	25
		CFH12-1VB	CFH12-1VUUB	CFH12-1VRB	CFH12-1VURB							
16	0 -0.018	CFH16B	CFH16UUB	CFH16RB	CFH16URB	35	18	16	M16×1.5	17	52	32.5
		CFH16VB	CFH16VUUB	CFH16VRB	CFH16VURB							
18	0 -0.018	CFH18B	CFH18UUB	CFH18RB	CFH18URB	40	20	18	M18×1.5	19	58	36.5
		CFH18VB	CFH18VUUB	CFH18VRB	CFH18VURB							
20	0 -0.021	CFH20B	CFH20UUB	CFH20RB	CFH20URB	52	24	20	M20×1.5	21	66	40.5
		CFH20VB	CFH20VUUB	CFH20VRB	CFH20VURB							
20	0 -0.021	CFH20-1B	CFH20-1UUB	CFH20-1RB	CFH20-1URB	47	24	20	M20×1.5	21	66	40.5
		CFH20-1VB	CFH20-1VUUB	CFH20-1VRB	CFH20-1VURB							
24	0 -0.021	CFH24B	CFH24UUB	CFH24RB	CFH24URB	62	29	24	M24×1.5	25	80	49.5
		CFH24VB	CFH24VUUB	CFH24VRB	CFH24VURB							
24	0 -0.021	CFH24-1B	CFH24-1UUB	CFH24-1RB	CFH24-1URB	72	29	24	M24×1.5	25	80	49.5
		CFH24-1VB	CFH24-1VUUB	CFH24-1VRB	CFH24-1VURB							
30	0 -0.021	CFH30B	CFH30UUB	CFH30RB	CFH30URB	80	35	30	M30×1.5	32	100	63
		CFH30VB	CFH30VUUB	CFH30VRB	CFH30VURB							
30	0 -0.021	CFH30-1B	CFH30-1UUB	CFH30-1RB	CFH30-1URB	85	35	30	M30×1.5	32	100	63
		CFH30-1VB	CFH30-1VUUB	CFH30-1VRB	CFH30-1VURB							
30	0 -0.021	CFH30-2B	CFH30-2UUB	CFH30-2RB	CFH30-2URB	90	35	30	M30×1.5	32	100	63
		CFH30-2VB	CFH30-2VUUB	CFH30-2VRB	CFH30-2VURB							

* Without seals, suitable for grease lubrication. In case of oil lubrication, up to 130% of this value shall be permissible, and 70% of this value shall apply for types with seals.

OUTER RINGS TOLERANCE (μm)

TYPE	Cylindrical outer ring	Crowned outer ring
CF12	0/-9	0/-50
CF12-1,CF16,CF18,CF20-1	0/-11	0/-50
CF20,CF24,CF24-1,CF30	0/-13	0/-50
CF30-1,CF30-2	0/-15	0/-50

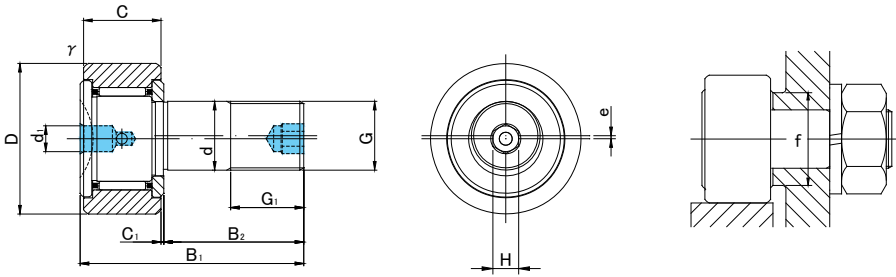

Prepacked Grease

C1	d1	H	rs min	e	f min	Basic dynamic load rating		Largest permissible load	Limiting speed *	Track load capacity		Max tightening torque	Mass
						Cr N	Cor N			Cylindrical outer ring N	Crowned outer ring N		
0.6	6	6	0.6	0.4	20	7 940	9 800	9 800	14 000	7 060	2 450	22	95
						13 430	19 700	11 270	6 000				
0.6	6	6	0.6	0.4	20	7 940	9 800	9 800	14 000	7 450	2 740	22	105
						13 430	19 700	11 270	6 000				
0.8	6	6	0.6	0.5	24	12 050	18 330	18 330	10 000	11 200	3 140	58	170
						20 680	37 630	19 800	4 500				
0.8	6	6	1	0.6	26	14 700	25 200	25 200	8 500	14 400	3 720	87	250
						25 280	51 350	26 560	3 500				
0.8	8	8	1	0.7	36	20 680	34 600	32 140	7 000	23 200	8 230	120	460
						33 120	64 480	32 140	3 500				
0.8	8	8	1	0.7	36	20 680	34 600	32 140	7 000	21 000	7 150	120	385
						33 120	64 480	32 140	3 500				
0.8	8	8	1	0.8	40	30 480	52 630	49 500	6 500	34 200	10 500	220	815
						46 550	92 020	49 500	3 000				
0.8	8	8	1	0.8	40	30 480	52 630	49 500	6 500	39 800	12 900	220	1 140
						46 550	92 020	49 500	3 000				
1	8	8	1	1	46	45 370	85 060	73 700	5 000	52 600	14 900	450	1 870
						67 620	144 060	73 700	2 200				
1	8	8	1	1	46	45 370	85 060	73 700	5 000	56 000	16 100	450	2 030
						67 620	144 060	73 700	2 200				
1	8	8	1	1	46	45 370	85 060	73 700	5 000	59 300	17 300	450	2 220
						67 620	144 060	73 700	2 200				

ACCESSORIES

TYPE			
CF12/CF12-1/CF16/CF18	φ 6 Attached	φ 6 Attached	Attached
CF20/CF20-1/CF24/CF24-1/CF30/CF30-2	φ 8 Attached	φ 8 Attached	Attached



CAM FOLLOWERS

TAP HOLE FOR PIPING
SCREWDRIVER SLOT HEAD

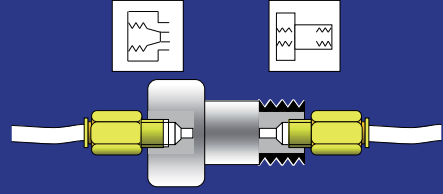

CFT



CFT.V

CFT TYPE

Stud diameter (mm)	h7 tolerance	Designation				Dimensions (mm)								
		Cylindrical outer ring		Crowned outer ring R500(CF6 ~ CF18)		D	C	d	G	G1	B1	B2	B3	C1
		Without seals	With seals	Without seals	With seals									
6	0 -0.012	CFT 6	CFT 6UU	CFT 6R	CFT 6UUR	16	11	6	M6×1	8	28	16	—	0.6
		CFT 6V	CFT 6VUU	CFT 6VR	CFT 6VUUR									
8	0 -0.015	CFT 8	CFT 8UU	CFT 8R	CFT 8UUR	19	11	8	M8×1.25	10	32	20	—	0.6
		CFT 8V	CFT 8VUU	CFT 8VR	CFT 8VUUR									
10	0 -0.015	CFT10	CFT10UU	CFT10R	CFT10UUR	22	12	10	M10×1.25	12	36	23	—	0.6
		CFT10V	CFT10VUU	CFT10VR	CFT10VUUR									
10	0 -0.015	CFT10-1	CFT10-1UU	CFT10-1R	CFT10-1UUR	26	12	10	M10×1.25	12	36	23	—	0.6
		CFT10-1V	CFT10-1VUU	CFT10-1VR	CFT10-1VUUR									
12	0 -0.018	CFT12	CFT12UU	CFT12R	CFT12UUR	30	14	12	M12×1.5	13	40	25	6	0.6
		CFT12V	CFT12VUU	CFT12VR	CFT12VUUR									
12	0 -0.018	CFT12-1	CFT12-1UU	CFT12-1R	CFT12-1UUR	32	14	12	M12×1.5	13	40	25	6	0.6
		CFT12-1V	CFT12-1VUU	CFT12-1VR	CFT12-1VUUR									
16	0 -0.018	CFT16	CFT16UU	CFT16R	CFT16UUR	35	18	16	M16×1.5	17	52	32.5	8	0.8
		CFT16V	CFT16VUU	CFT16VR	CFT16VUUR									
18	0 -0.018	CFT18	CFT18UU	CFT18R	CFT18UUR	40	20	18	M18×1.5	19	58	36.5	8	0.8
		CFT18V	CFT18VUU	CFT18VR	CFT18VUUR									

* Without seals, suitable for grease lubrication. In case of oil lubrication, up to 130% of this value shall be permissible, and 70% of this value shall apply for types with seals.

OUTER RINGS TOLERANCE (μm)

TYPE	Cylindrical outer ring	Crowned outer ring
CF6	0/-8	0/-50
CF8,CF10,CF10-1,CF12	0/-9	0/-50
CF12-1,CF16,CF18,CF20-1	0/-11	0/-50
CF20,CF24,CF24-1,CF30	0/-13	0/-50
CF30-1,CF30-2	0/-15	0/-50

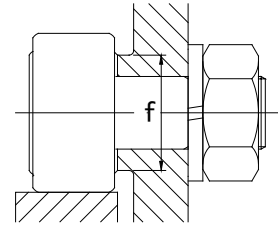
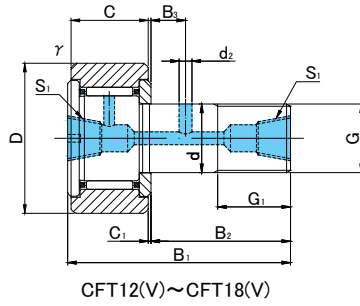
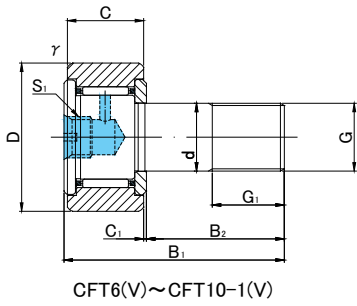

Prepacked Grease

				Basic dynamic load rating	Basic static load rating	Largest permissible load	Limiting speed *	Track load capacity		Max tightening torque	Mass
S1	d2	f/s min	f min	Cr N	Cor N	N	rpm	Cylindrical outer ring N	Crowned outer ring N	N·m	g (approx)
M6×0.75	—	0.3	11	3 630	3 630	2 110	25 000	3 430	1 080	3	18.5
				6 960	8 530	2 110	12 000				
M6×0.75	—	0.3	13	4 310	4 710	4 710	20 000	4 020	1 370	8	28.5
				8 130	11 170	4 710	9 000				
M6×0.75	—	0.3	15	5 390	6 860	6 860	17 000	4 700	1 670	15	45
				9 510	14 500	7 450	7 500				
M6×0.75	—	0.3	15	5 390	6 860	6 860	17 000	5 490	2 060	15	60
				9 510	14 500	7 450	7 500				
M6×0.75	3	0.6	20	7 940	9 800	9 800	14 000	7 060	2 450	22	95
				13 430	19 700	11 270	6 000				
M6×0.75	3	0.6	20	7 940	9 800	9 800	14 000	7 450	2 740	22	105
				13 430	19 700	11 270	6 000				
Rc1/8	3	0.6	24	12 050	18 330	18 330	10 000	11 200	3 140	58	170
				20 680	37 630	19 800	4 500				
Rc1/8	3	1	26	14 700	25 200	25 200	8 500	14 400	3 720	87	250
				25 280	51 350	26 560	3 500				

ACCESSORIES

TYPE	
All types	Attached



CAM FOLLOWERS

TAP HOLE FOR PIPING
SCREWDRIVER SLOT HEAD

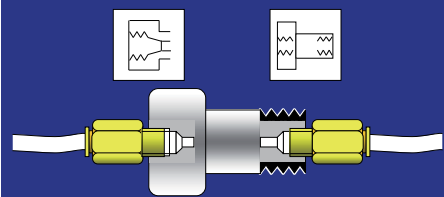

CFT



CFT.V

CFT TYPE

Stud diameter (mm)	h7 tolerance	Designation				Dimensions (mm)								
		Cylindrical outer ring		Crowned outer ring R1000(CF20 ≤)		D	C	d	G	G1	B1	B2	B3	C1
		Without seals	With seals	Without seals	With seals									
20	0 -0.021	CFT20	CFT20UU	CFT20R	CFT20UUR	52	24	20	M20×1.5	21	66	40.5	9	0.8
		CFT20V	CFT20VUU	CFT20VR	CFT20VUUR									
20	0 -0.021	CFT20-1	CFT20-1UU	CFT20-1R	CFT20-1UUR	47	24	20	M20×1.5	21	66	40.5	9	0.8
		CFT20-1V	CFT20-1VUU	CFT20-1VR	CFT20-1VUUR									
24	0 -0.021	CFT24	CFT24UU	CFT24R	CFT24UUR	62	29	24	M24×1.5	25	80	49.5	11	0.8
		CFT24V	CFT24VUU	CFT24VR	CFT24VUUR									
24	0 -0.021	CFT24-1	CFT24-1UU	CFT24-1R	CFT24-1UUR	72	29	24	M24×1.5	25	80	49.5	11	0.8
		CFT24-1V	CFT24-1VUU	CFT24-1VR	CFT24-1VUUR									
30	0 -0.021	CFT30	CFT30UU	CFT30R	CFT30UUR	80	35	30	M30×1.5	32	100	63	15	1
		CFT30V	CFT30VUU	CFT30VR	CFT30VUUR									
30	0 -0.021	CFT30-1	CFT30-1UU	CFT30-1R	CFT30-1UUR	85	35	30	M30×1.5	32	100	63	15	1
		CFT30-1V	CFT30-1VUU	CFT30-1VR	CFT30-1VUUR									
30	0 -0.021	CFT30-2	CFT30-2UU	CFT30-2R	CFT30-2UUR	90	35	30	M30×1.5	32	100	63	15	1
		CFT30-2V	CFT30-2VUU	CFT30-2VR	CFT30-2VUUR									

* Without seals, suitable for grease lubrication. In case of oil lubrication, up to 130% of this value shall be permissible, and 70% of this value shall apply for types with seals.

OUTER RINGS TOLERANCE (μm)

TYPE	Cylindrical outer ring	Crowned outer ring
CF6	0/-8	0/-50
CF8,CF10,CF10-1,CF12	0/-9	0/-50
CF12-1,CF16,CF18,CF20-1	0/-11	0/-50
CF20,CF24,CF24-1,CF30	0/-13	0/-50
CF30-1,CF30-2	0/-15	0/-50

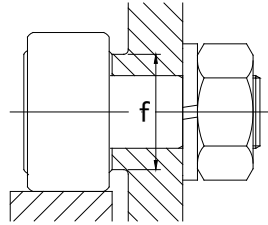
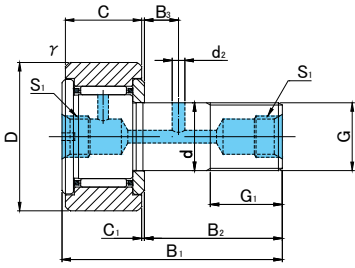

Prepacked Grease

				Basic dynamic load rating	Basic static load rating	Largest permissible load	Limiting speed *	Track load capacity		Max tightening torque	Mass
S1	d2	f/s min	f min	Cr N	Cor N	N	rpm	Cylindrical outer ring N	Crowned outer ring N	N·m	g (approx)
Rc1/8	4	1	36	20 680	34 600	32 140	7 000	23 200	8 230	120	460
				33 120	64 480	32 140	3 500				
Rc1/8	4	1	36	20 680	34 600	32 140	7 000	21 000	7 150	120	385
				33 120	64 480	32 140	3 500				
Rc1/8	4	1	40	30 480	52 630	49 500	6 500	34 200	10 500	220	815
				46 550	92 020	49 500	3 000				
Rc1/8	4	1	40	30 480	52 630	49 500	6 500	39 800	12 900	220	1 140
				46 550	92 020	49 500	3 000				
Rc1/8	4	1	46	45 370	85 060	73 700	5 000	52 600	14 900	450	1 870
				67 620	144 060	73 700	2 200				
Rc1/8	4	1	46	45 370	85 060	73 700	5 000	56 000	56 000	450	2 030
				67 620	144 060	73 700	2 200				
Rc1/8	4	1	46	45 370	85 060	73 700	5 000	59 300	59 300	450	2 220
				67 620	144 060	73 700	2 200				

ACCESSORIES

TYPE	
All types	NUT Attached



CAM FOLLOWERS

TAP HOLE FOR PIPING
HEXAGON SOCKET ON STUD HEAD

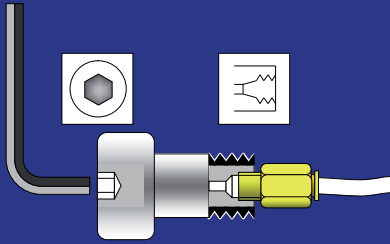

CFT..A



CFT..VA

CFT..A TYPE

Stud diameter (mm)	Designation	Dimensions (mm)											
		Cylindrical outer ring				Crowned outer ring R500(CF12 ~ CF18) R1000(CF20 ≤)							
h7 tolerance	Without seals	With seals	Without seals	With seals	D	C	d	G	G1	B1	B2	B3	C1
12	CFT12A	CFT12UUA	CFT12RA	CFT12UURA	30	14	12	M12×1.5	13	40	25	6	0.6
	CFT12VA	CFT12VUUA	CFT12VRA	CFT12VUURA									
12	CFT12-1A	CFT12-1UUA	CFT12-1RA	CFT12-1UURA	32	14	12	M12×1.5	13	40	25	6	0.6
	CFT12-1VA	CFT12-1VUUA	CFT12-1VRA	CFT12-1VUURA									
16	CFT16A	CFT16UUA	CFT16RA	CFT16UURA	35	18	16	M16×1.5	17	52	32.5	8	0.8
	CFT16VA	CFT16VUUA	CFT16VRA	CFT16VUURA									
18	CFT18A	CFT18UUA	CFT18RA	CFT18UURA	40	20	18	M18×1.5	19	58	36.5	8	0.8
	CFT18VA	CFT18VUUA	CFT18VRA	CFT18VUURA									
20	CFT20A	CFT20UUA	CFT20RA	CFT20UURA	52	24	20	M20×1.5	21	66	40.5	9	0.8
	CFT20VA	CFT20VUUA	CFT20VRA	CFT20VUURA									
20	CFT20-1A	CFT20-1UUA	CFT20-1RA	CFT20-1UURA	47	24	20	M20×1.5	21	66	40.5	9	0.8
	CFT20-1VA	CFT20-1VUUA	CFT20-1VRA	CFT20-1VUURA									
24	CFT24A	CFT24UUA	CFT24RA	CFT24UURA	62	29	24	M24×1.5	25	80	49.5	11	0.8
	CFT24VA	CFT24VUUA	CFT24VRA	CFT24VUURA									
24	CFT24-1A	CFT24-1UUA	CFT24-1RA	CFT24-1UURA	72	29	24	M24×1.5	25	80	49.5	11	0.8
	CFT24-1VA	CFT24-1VUUA	CFT24-1VRA	CFT24-1VUURA									
30	CFT30A	CFT30UUA	CFT30RA	CFT30UURA	80	35	30	M30×1.5	32	100	63	15	1
	CFT30VA	CFT30VUUA	CFT30VRA	CFT30VUURA									
30	CFT30-1A	CFT30-1UUA	CFT30-1RA	CFT30-1UURA	85	35	30	M30×1.5	32	100	63	15	1
	CFT30-1VA	CFT30-1VUUA	CFT30-1VRA	CFT30-1VUURA									
30	CFT30-2A	CFT30-2UUA	CFT30-2RA	CFT30-2UURA	90	35	30	M30×1.5	32	100	63	15	1
	CFT30-2VA	CFT30-2VUUA	CFT30-2VRA	CFT30-2VUURA									

* Without seals, suitable for grease lubrication. In case of oil lubrication, up to 130% of this value shall be permissible, and 70% of this value shall apply for types with seals.

OUTER RINGS TOLERANCE

TYPE	Cylindrical outer ring	Crowned outer ring
CF12	0/-9	0/-50
CF12-1,CF16,CF18,CF20-1	0/-11	0/-50
CF20,CF24,CF24-1,CF30	0/-13	0/-50
CF30-1,CF30-2	0/-15	0/-50

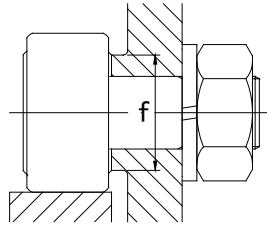
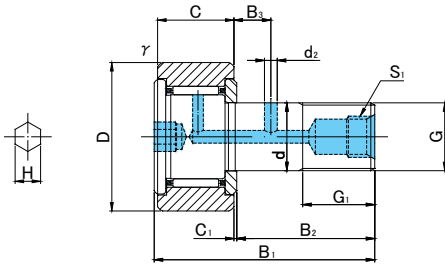

Prepacked Grease

					Basic dynamic load rating	Basic static load rating	Largest permissible load	Limiting speed *	Track load capacity		Max tightening torque	Mass
S1	d2	H	f_s min	f min	Cr N	Cor N	N	rpm	Cylindrical outer ring N	Crowned outer ring N	N·m	g (approx)
M6×0.75	3	6	0.6	20	7 940	9 800	9 800	14 000	7 060	2 450	22	95
					13 430	19 700	11 270	6 000				
M6×0.75	3	6	0.6	20	7 940	9 800	9 800	14 000	7 450	2 740	22	105
					13 430	19 700	11 270	6 000				
Rc1/8	3	6	0.6	24	12 050	18 330	18 330	10 000	11 200	3 140	58	170
					20 680	37 630	19 800	4 500				
Rc1/8	3	6	1	26	14 700	25 200	25 200	8 500	14 400	3 720	87	250
					25 280	51 350	26 560	3 500				
Rc1/8	4	8	1	36	20 680	34 600	32 140	7 000	23 200	8 230	120	460
					33 120	64 480	32 140	3 500				
Rc1/8	4	8	1	36	20 680	34 600	32 140	7 000	21 000	7 150	120	385
					33 120	64 480	32 140	3 500				
Rc1/8	4	8	1	40	30 480	52 630	49 500	6 500	34 200	10 500	220	815
					46 550	92 020	49 500	3 000				
Rc1/8	4	8	1	40	30 480	52 630	49 500	6 500	39 800	12 900	220	1 140
					46 550	92 020	49 500	3 000				
Rc1/8	4	8	1	46	45 370	85 060	73 700	5 000	52 600	14 900	450	1 870
					67 620	144 060	73 700	2 200				
Rc1/8	4	8	1	46	45 370	85 060	73 700	5 000	56 000	56 000	450	2 030
					67 620	144 060	73 700	2 200				
Rc1/8	4	8	1	46	45 370	85 060	73 700	5 000	59 300	59 300	450	2 220
					67 620	144 060	73 700	2 200				

ACCESSORIES

TYPE	
All types	Attached

CFT...A



CAM FOLLOWERS

INCH DIMENSION
SCREWDRIVER SLOT HEAD

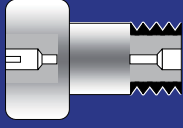

CR

CR TYPE

Stud diameter	Designation				Dimensions (inch/mm)										
	Cylindrical outer ring		Crowned outer ring R250(≤ CR8-1) R500(CR10 ≤)		D		C		d		G	G1	B1		
	Without seals	With seals	Without seals	With seals											
4.826 (-)	CR8	CR8UU	CR8R	CR8UUR	1/2	12.7	11/32	8.731	—	4.826	No.10-32	1/4	6.35	7/8	22.225
	CR8-1	CR8-1UU	CR8-1R	CR8-1UUR			3/8	9.525						1 1/32	26.194
6.350 (1/4)	CR10	CR10UU	CR10R	CR10UUR	5/8	15.875	13/32	10.319	1/4	6.35	1/4 - 28	5/16	7.938	1 1/16	26.988
	CR10-1	CR10-1UU	CR10-1R	CR10-1UUR			7/16	11.112						1 7/32	30.956
9.525 (3/8)	CR12	CR12UU	CR12R	CR12UUR	3/4	19.05	1/2	12.7	3/8	9.525	3/8 - 24	3/8	9.525	1 13/32	35.719
	CR14	CR14UU	CR14R	CR14UUR	7/8	22.225									
11.112 (7/16)	CR16	CR16UU	CR16R	CR16UUR	1	25.4	5/8	15.875	7/16	11.112	7/16 - 20	1/2	12.7	1 21/32	42.069
	CR18	CR18UU	CR18R	CR18UUR	1 1/8	28.575									
12.700 (1/2)	CR20	CR20UU	CR20R	CR20UUR	1 1/4	31.75	3/4	19.05	1/2	12.7	1/2 - 20	5/8	15.875	2 1/32	51.594
	CR22	CR22UU	CR22R	CR22UUR	1 3/8	34.925									
15.875 (5/8)	CR24	CR24UU	CR24R	CR24UUR	1 1/2	38.1	7/8	22.225	5/8	15.875	5/8 - 18	3/4	19.05	2 13/32	61.119
	CR26	CR26UU	CR26R	CR26UUR	1 5/8	41.275									
19.05 (3/4)	CR28	CR28UU	CR28R	CR28UUR	1 3/4	44.45	1	25.4	3/4	19.05	3/4 - 16	7/8	22.225	2 25/32	70.644
	CR30	CR30UU	CR30R	CR30UUR	1 7/8	47.625									
22.225 (7/8)	CR32	CR32UU	CR32R	CR32UUR	2	50.8	1 1/4	31.75	7/8	22.225	7/8 - 14	1	25.4	3 9/32	83.344
	CR36	CR36UU	CR36R	CR36UUR	2 1/4	57.15									

* Without seals, suitable for grease lubrication. In case of oil lubrication, up to 130% of this value shall be permissible, and 70% of this value shall apply for types with seals.

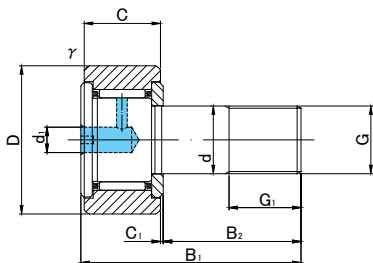

CR8~CR10-1

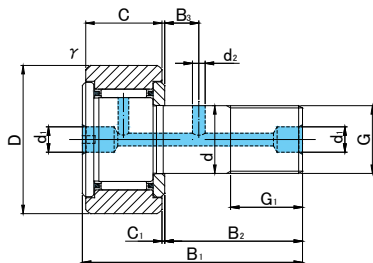

CR12~CR36

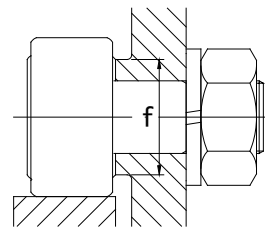

Prepacked Grease

												Basic dynamic load rating	Basic static load rating	Limiting speed *	Track load capacity		Max tightening torque	Mass	
B2		B3		C1	d1		d2		r		f		Cr N	Cor N	rpm	Cylindrical outer ring N	Crowned outer ring N	N·m	g (approx)
1/2	12.7	—	—	0.8	1/8	3.175	—	—	1/64	0.397	21/64	8.334	2 550	2 160	28 000	2 160	730	2	9
5/8	15.875	—	—	0.8	1/8	3.175	—	—	1/64	0.397	29/64	11.509	3 630	3 630	21 000	3 430	1 180	3	19
3/4	19.05	—	—	0.8	1/8	3.175	—	—	1/64	0.397	29/64	11.509	3 630	3 630	21 000	3 430	1 180	3	21
7/8	22.225	1/4	6.35	0.8	3/16	4.762	3/32	2.381	1/32	0.794	17/32	13.494	4 410	5 100	15 000	4 510	1 270	17	35
											19/32	15.081	4 800	5 780	14 000	5 290	1 760		
1	25.4	1/4	6.35	0.8	3/16	4.762	1/8	3.175	3/64	1.191	45/64	17.859	8 820	10 780	13 000	7 250	1 960	20	73
											1/16	1.588	3/4	19.05	9 210	11 560	12 000		
1 1/4	31.75	5/16	7.938	0.8	3/16	4.762	1/8	3.175	1/16	1.588	55/64	21.828	14 210	15 970	11 000	10 680	2 840	28	132
																11 760	2 940		
1 1/2	38.1	3/8	9.525	0.8	3/16	4.762	5/32	3.969	1/16	1.588	1 3/64	26.196	18 520	24 210	8 500	15 390	3 820	64	225
																16 660	3 820		
1 3/4	44.45	7/16	11.112	0.8	3/16	4.762	5/32	3.969	1/16	1.588	1 9/32	32.543	25 090	38 220	7 000	20 970	3 820	117	365
																22 440	4 700		
2	50.8	1/2	12.7	0.8	3/16	4.762	3/16	4.762	1/16	1.588	1 15/32	37.306	32 440	63 800	5 500	30 870	4 900	186	615
																34 690	5 980		

ACCESSORIES



TYPE			
CR8, CR8-1, CR10, CR10-1	—	—	Attached
CR12, CR14, CR16, CR18, CR20, CR22	φ 4.8 Attached	φ 4.8 Attached	Attached
CR24, CR26, CR28, CR30, CR32, CR36	φ 4.8 Attached	φ 4.8 Attached	Attached



ROLLER FOLLOWERS

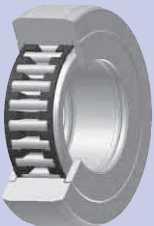
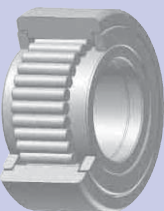
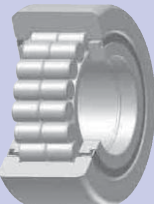

Type and Part Code

Type	Applicable shaft diameter	Feature
 <p>RNAST (Separable type)</p>	$\phi 7 \sim \phi 60$	<p>RNAST type without inner ring. Available with stainless steel type (code M) for higher corrosive resistance.</p>
 <p>NAST (Separable type)</p>	$\phi 6 \sim \phi 50$	<p>Thick wall outer ring, inner ring. Separable bearing with combined needle roller with precision cage. Available with stainless steel type (code M) for higher corrosive resistance.</p>
 <p>NAST-ZZ (Separable type)</p>	$\phi 6 \sim \phi 50$	<p>Separable bearing in which labyrinth seal is formed with combined side plate at both sides of inner ring of NAST type. (NAST-ZZUU type comes with seal) Available with stainless steel type (code M) for higher corrosive resistance.</p>
 <p>NART-R (Non-separable type)</p>	$\phi 5 \sim \phi 50$	<p>Non-separable bearing with fixed side plate at inner ring. Mitigate eccentric load with spherical shape at outer diameter of outer ring (Code R). (NART-UUR type comes with seal) Available with stainless steel type (code M) for higher corrosive resistance.</p>
 <p>NURT-R (Double-row cylindrical roller)</p>	$\phi 15 \sim \phi 50$	<p>Bearing which allows high radial loading and moderate axial loading with integrated cylindrical roller in double rows. Mitigate eccentric load with spherical shape at outer diameter of outer ring (Code R).</p>

Part Code

RNAST

↑
Type

15 M

↑
M: Stainless steel
None: High Carbon steel

R

↑
R: Crowned outer ring
None: Cylindrical outer ring

NAST

↑
Type

15 M

↑
M: Stainless steel
None: High Carbon steel

R

↑
R: Crowned outer ring
None: Cylindrical outer ring

NAST

↑
Type

15 M

↑
M: Stainless steel
None: High Carbon steel

ZZ

↑
ZZ: With shield

UU

↑
UU: With seal
None: With shield

R

↑
R: Crowned outer ring
None: Cylindrical outer ring

NART

↑
Type

15 M

↑
M: Stainless steel
None: High Carbon steel

UU

↑
UU: With seal
None: With shield

V

↑
V: Full complement
None: With cage

R

↑
R: Crowned outer ring
X: Cylindrical outer ring

NURT

↑
Type

15

R

↑
R: Crowned outer ring
X: Cylindrical outer ring

Structure and Features

Roller follower is a bearing with integrated "roller" featuring high rigidity. Its primary application is in a guide roller to have its contacting member travel in linear motion in direction of tangent using rotation of outer ring.

Outer ring of the roller follower is designed with thick ring in order to provide high rigidity to endure heavy load or impact load at portion to contact with the associated objects.

Type of roller follower mainly consists of separate type, which have separated inner ring and outer ring, and non-separate type, whose inner ring has fixed side plate.

Also, various types with shapes and structures are available in accordance with application. Outer rings have two types – crowned outer ring and cylindrical outer ring. The crowned outer ring is suited for absorbing eccentric load since it absorbs angular misalignment due to a mount error. Cylindrical outer ring is effective for heavy duty since it contacts with large contact area of the associated objects so that can mitigate the contact surface pressure. They have two internal mechanism – one with cage and one with full complement. A roller follower with cage is suitable for high speed application since the guiding feature of cage enables the rotation of "rollers" to be stable. Compared with cage type, full complement type is effective for applications with low-speed operation of heavy load due to its larger load rating. Full complement type also includes double-row cylindrical roller type which allows moderate axial loading.

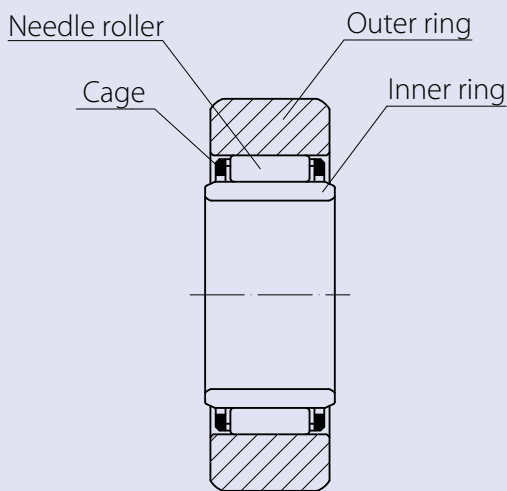

Structure of type NAST

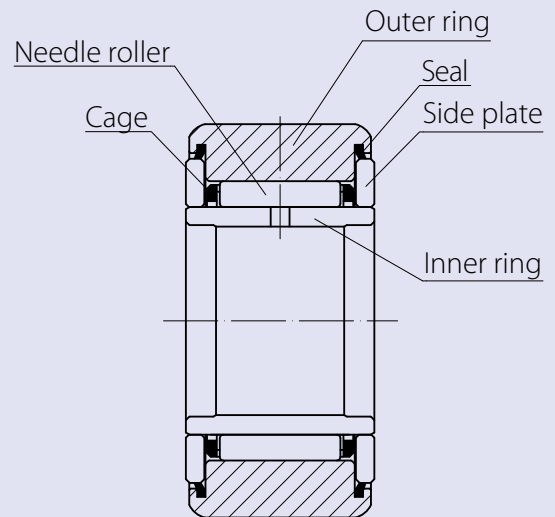

Structure of type NART..UUR

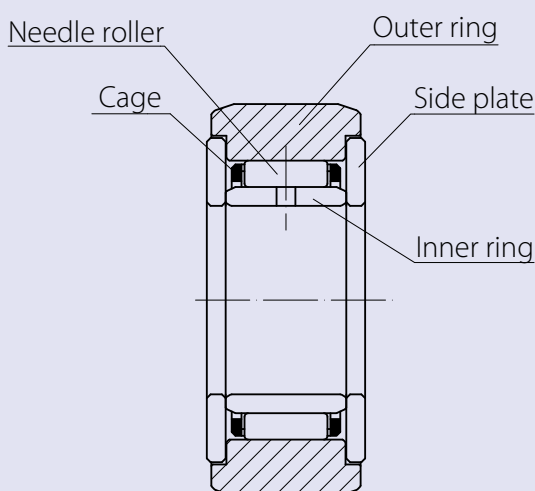

Structure of type NAST..ZZ

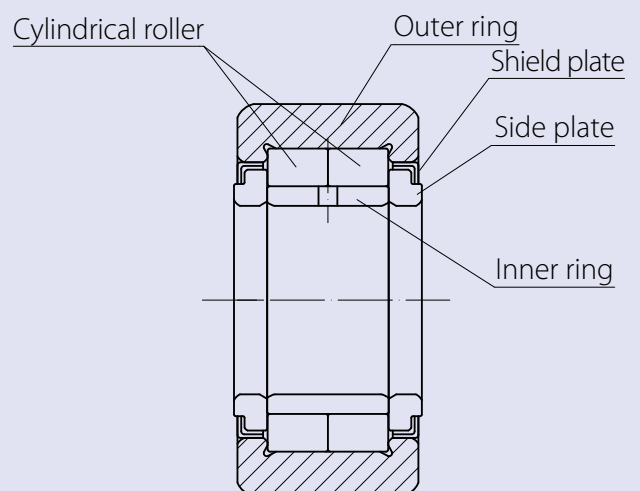

Structure of type NURT

Accuracy standard

Roller followers are manufactured in accordance with the following accuracies.

Table-1 Accuracy

Unit: μm

Name	Category	Crowned outer ring	Cylindrical outer ring
Dimension tolerance of outer ring outer diameter (D)		0 -50	Refer to Table-3
Dimension tolerance of outer ring width (C)		0 -120	
Tolerance of inner ring width (B)	Separable	0 -120	
Tolerance of bearing width (B)	Non-separable	h12	—
Fw	Separable	Refer to Table-11 on page 23	

Table-2 Accuracy of inner ring

Unit: μm

Nominal inner ring bore diameter d (mm)		Deviation of mean bore diameter in a single plane Δ_{dmp}		Tolerance of radial runout of inner ring
Over	Incl.	high	low	max.
2.5	10	0	-8	10
10	18	0	-9	10
18	30	0	-10	13
30	50	0	-12	15

Table-3 Accuracy of outer ring

Unit: μm

Nominal outer ring bore diameter D (mm)		Deviation of mean outer diameter in a single plane Δ_{Dmp}		Tolerance of radial runout of outer ring (max.)
Over	Incl.	high	low	max.
6	18	0	-8	15
18	30	0	-9	15
30	50	0	-11	20
50	80	0	-13	25
80	120	0	-15	35

Radial internal clearance

Table below indicates radial internal clearance of roller follower.

Table-4 Radial internal clearance

Unit: μm

Part code			Radial internal clearance	
Separable	Non-separable	Double row cylindrical roller	min.	max.
NAST6	NART5R ~ 6R		5	20
NAST8 ~ 12	NART8R ~ 12R		5	25
NAST15 ~ 25	NART15R ~ 25R		10	30
NAST30 ~ 40	NART30R ~ 40R		10	40
NAST45 ~ 50	NART45R ~ 50R		15	50
		NURT15R ~ 30-1R	0	25
		NURT35R ~ 40-1R	5	30
		NURT45R ~ 50-1R	5	35

Fits

Table below indicates recommended fits between roller follower and its mounting shaft.

Table-5 Shaft fits

Type		Tolerance grade
Separable	Without inner ring	k5,k6
	With inner ring	g6,h6
Non-separable		
Double row cylindrical roller		

Track load capacity

Track load capacity means a permissive load under which the outer ring of cam follower and the mating surface are allowable to be used over a long period without causing any deformation nor compression mark. Track load capacity depicted in dimension table indicates a value for which hardness of contacting steel member is assumed to be HRC40. In the case that the hardness of contacting member is not HRC40, track load capacity in the dimension table shall be multiplied by value of track capacity factor obtained by Figure-1.

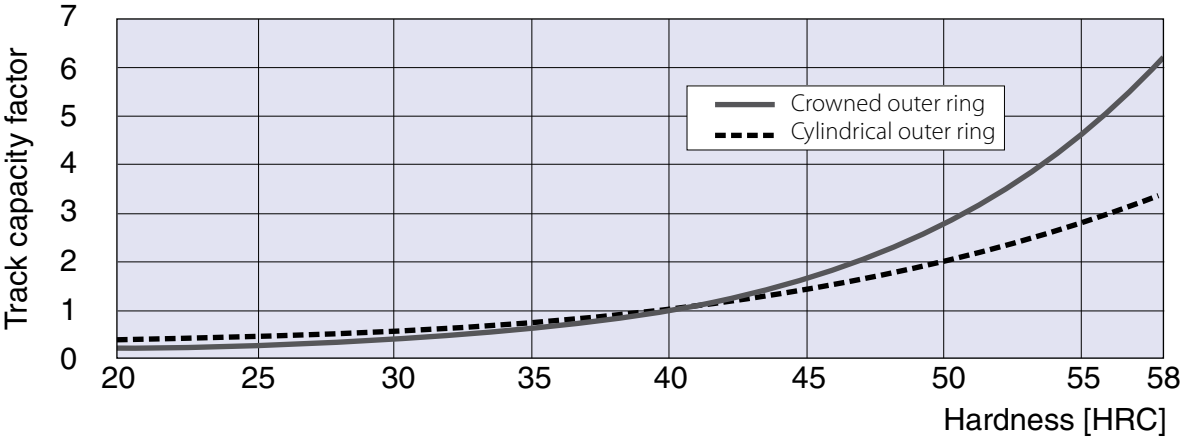

Figure-1 Track capacity factor

Lubrication

All the JNS roller followers are lubricated with pre-packed high quality lithium soap-based grease grade 2 (RoHS compliant) so that they are ready to use. For applications requiring high prevention measure against invasion of foreign matter or leakage of lubricant, products with seal (part code--UU) which integrate special synthetic lubber with high abrasion resistance are also available.

Grease shall be packed up to volume approximately one-third to one-half of internal space of bearing. Lubrication interval varies depending on operation condition. Referential interval may be every six to twenty four months for roller followers with cages and every one to six months for full complement type with grease in the same type.

Some excessive grease may leak at the beginning of usage or immediately after re-greasing even for the products with seal. Aging operation period is recommended prior to application in which no contamination by grease is allowed in and around device. Wipe and clean any leaked extra grease after this operation.

Mounting

Mounting part

- Thrust load may cause damage to side plate, outer ring or roller follower since it is designed so as to support load in radial direction. It is recommended to design and assemble to avoid thrust load.
- Application with roller follower without inner ring requires heat treatment and grinding finish of shaft. Surface hardness of the shaft shall be HRC58 to 64, and surface roughness shall be R_a 0.2 μ m or less for this application.
- Side plate of non-separate type roller follower is pressed-in to fix it. Application in a manner to push the side plate shall be avoided in order to prevent risk of abnormal rotation under external force.
- Crowned outer ring is recommended in the case that contact between the outer ring and contacting member track surface is not smooth and even.
- When mounting NART, NAST-ZZ and NURT type, dimension "a" must be more than it described in dimension table in order to protect the side plate.

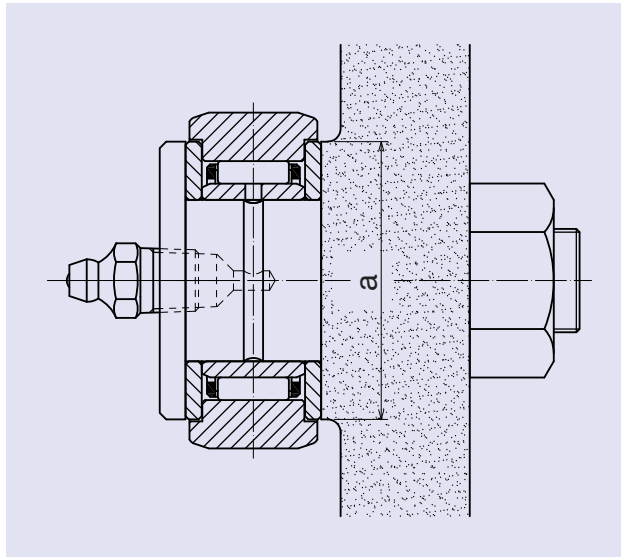

Mounting method

To prevent pre-mature failure of roller follower, lubrication hole of inner ring shall be located outside of loading range (on the side to receive load).

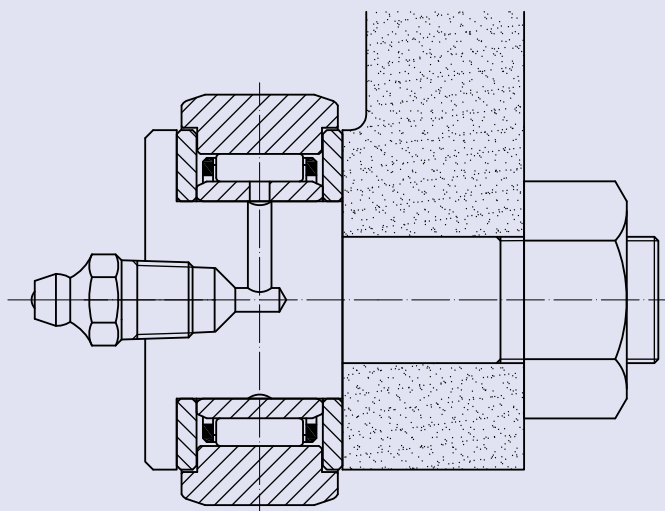

NAST..ZZ Example of mounting

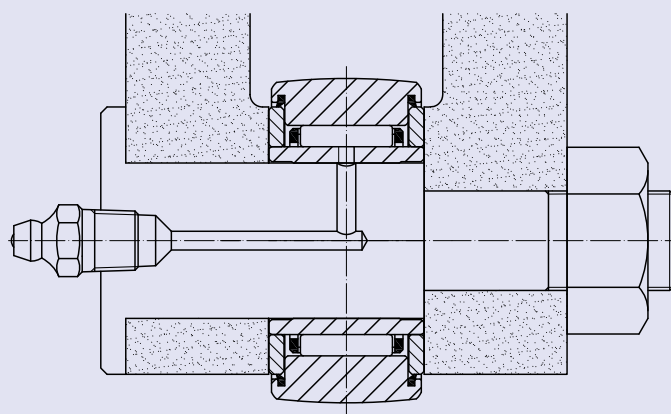

NART..UUR Example of mounting

ROLLER FOLLOWERS

SEPARABLE WITHOUT INNER RING



RNAS T

RNAS T TYPE

Shaft Diameter (mm)	Designation		Dimensions (mm)			
	Cylindrical outer ring	Crowned outer ring (R500)	Fw	D	C	
7	RNAS T 5	RNAS T 5R	7 +0.022 +0.013	16	7.8	
10	RNAS T 6	RNAS T 6R	10 +0.027 +0.016	19	9.8	
12	RNAS T 8	RNAS T 8R	12 +0.027 +0.016	24	9.8	
14	RNAS T10	RNAS T10R	14 +0.027 +0.016	30	11.8	
16	RNAS T12	RNAS T12R	16 +0.027 +0.016	32	11.8	
20	RNAS T15	RNAS T15R	20 +0.033 +0.020	35	11.8	
22	RNAS T17	RNAS T17R	22 +0.033 +0.020	40	15.8	
25	RNAS T20	RNAS T20R	25 +0.033 +0.020	47	15.8	
30	RNAS T25	RNAS T25R	30 +0.033 +0.020	52	15.8	
38	RNAS T30	RNAS T30R	38 +0.041 +0.025	62	19.8	
42	RNAS T35	RNAS T35R	42 +0.041 +0.025	72	19.8	
50	RNAS T40	RNAS T40R	50 +0.041 +0.025	80	19.8	
55	RNAS T45	RNAS T45R	55 +0.049 +0.030	85	19.8	
60	RNAS T50	RNAS T50R	60 +0.049 +0.030	90	19.8	

* Suitable for grease lubrication. In case of oil lubrication, up to 130% of this value shall be permissible.

OUTER RINGS TOLERANCE (µm)

TYPE	Cylindrical outer ring	Crowned outer ring
RNAS T5	0/-8	0/-50
RNAS T6,RNAS T8,RNAS T10	0/-9	0/-50
RNAS T12,RNAS T15,RNAS T17,RNAS T20	0/-11	0/-50
RNAS T25,RNAS T30,RNAS T35,RNAS T40	0/-13	0/-50
RNAS T45,RNAS T50	0/-15	0/-50



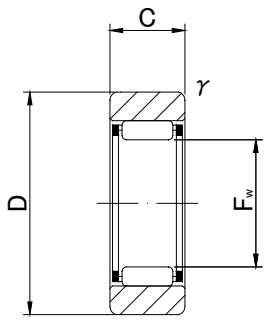



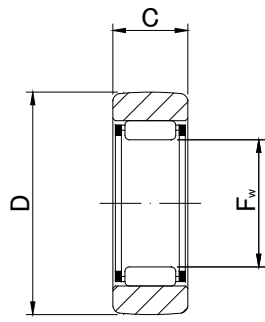



RNAS T



RNAS T..R

Prepacked Grease

f's min	Basic dynamic load rating	Basic static load rating	Track load capacity		Limiting speed *	Mass
	 Cr N	 Cor N	 Cylindrical outer ring N	 Crowned outer ring N	 rpm	 g (approx)
0.3	2 740	2 390	2 350	1 080	30 000	8.9
0.3	4 120	4 550	3 530	1 370	20 000	13.9
0.6	5 680	5 890	4 020	1 860	17 000	23.5
1	9 700	9 670	5 590	2 450	15 000	42.5
1	10 400	10 900	5 980	2 740	13 000	49.5
1	12 300	14 300	6 570	3 140	10 000	50
1	17 400	20 900	10 900	3 720	9 500	90
1	19 200	24 500	12 700	4 610	8 500	135
1	20 700	28 400	14 100	5 290	7 000	152
1	30 300	45 400	22 100	6 660	5 500	255
1	32 200	50 600	25 700	8 130	5 000	375
1.5	35 700	61 100	26 900	9 310	4 000	420
1.5	37 100	66 400	28 500	10 100	4 000	460
1.5	38 700	71 800	30 200	11 000	3 500	500

RNAS T



ROLLER FOLLOWERS

SEPARABLE WITH INNER RING



NAST

NAST TYPE

Shaft Diameter (mm)	Designation		Dimensions (mm)				
	Cylindrical outer ring	Crowned outer ring (R500)	d	D	B	C	r _s min
6	NAST 6	NAST 6R	6 ⁰ _{-0.008}	19	10	9.8	0.3
8	NAST 8	NAST 8R	8 ⁰ _{-0.008}	24	10	9.8	0.6
10	NAST10	NAST10R	10 ⁰ _{-0.008}	30	12	11.8	1
12	NAST12	NAST12R	12 ⁰ _{-0.008}	32	12	11.8	1
15	NAST15	NAST15R	15 ⁰ _{-0.008}	35	12	11.8	1
17	NAST17	NAST17R	17 ⁰ _{-0.010}	40	16	15.8	1
20	NAST20	NAST20R	20 ⁰ _{-0.010}	47	16	15.8	1
25	NAST25	NAST25R	25 ⁰ _{-0.010}	52	16	15.8	1
30	NAST30	NAST30R	30 ⁰ _{-0.010}	62	20	19.8	1
35	NAST35	NAST35R	35 ⁰ _{-0.012}	72	20	19.8	1
40	NAST40	NAST40R	40 ⁰ _{-0.012}	80	20	19.8	1.5
45	NAST45	NAST45R	45 ⁰ _{-0.012}	85	20	19.8	1.5
50	NAST50	NAST50R	50 ⁰ _{-0.012}	90	20	19.8	1.5

* Suitable for grease lubrication. In case of oil lubrication, up to 130% of this value shall be permissible.

OUTER RINGS TOLERANCE (Outside diameter) (μm)

TYPE	Cylindrical outer ring	Crowned outer ring
NAST6,NAST8,NAST10	0/-9	0/-50
NAST12,NAST15,NAST17,NAST20	0/-11	0/-50
NAST25,NAST30,NAST35,NAST40	0/-13	0/-50
NAST45,NAST50	0/-15	0/-50



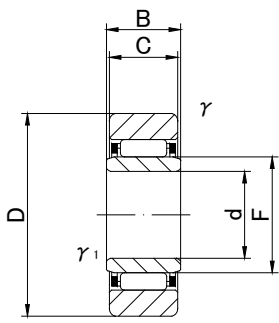

NAST

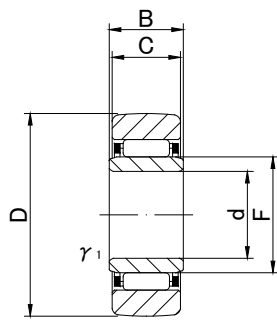

NAST..R

Prepacked Grease

		Basic dynamic load rating	Basic static load rating	Track load capacity		Limiting speed *	Mass
<i>r</i> 1s min	F	Cr N	Cor N	Cylindrical outer ring N	Crowned outer ring N	rpm	g (approx)
0.3	10	4 120	4 550	3 530	1 370	20 000	17.8
0.3	12	5 680	5 890	4 020	1 860	17 000	28
0.3	14	9 700	9 670	5 590	2 450	15 000	50
0.3	16	10 400	10 900	5 980	2 740	13 000	58
0.3	20	12 300	14 300	6 570	3 140	10 000	62
0.3	22	17 400	20 900	10 900	3 720	9 500	110
0.3	25	19 200	24 500	12 700	4 610	8 500	155
0.3	30	20 700	28 400	14 100	5 290	7 000	180
0.6	38	30 300	45 400	22 100	6 660	5 500	320
0.6	42	32 200	50 600	25 700	8 130	5 000	440
1	50	35 700	61 100	26 900	9 310	4 000	530
1	55	37 100	66 400	28 500	10 100	4 000	580
1	60	38 700	71 800	30 200	11 000	3 500	635



ROLLER FOLLOWERS

SEPARABLE
WITH INNER RING
WITH SHIELD

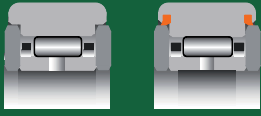

NAST..ZZ

NAST..ZZ TYPE

Shaft Diameter (mm)	Designation				Dimensions (mm)					
	Cylindrical outer ring		Crowned outer ring (R500)		d	D	B	C	a	
	Without seals	With seals	Without seals	With seals						
6	NAST 6ZZ	NAST 6ZZUU	NAST 6ZZR	NAST 6ZZUUR	6 ⁰ _{-0.008}	19	14	13.8	14	
8	NAST 8ZZ	NAST 8ZZUU	NAST 8ZZR	NAST 8ZZUUR	8 ⁰ _{-0.008}	24	14	13.8	17.5	
10	NAST10ZZ	NAST10ZZUU	NAST10ZZR	NAST10ZZUUR	10 ⁰ _{-0.008}	30	16	15.8	23.5	
12	NAST12ZZ	NAST12ZZUU	NAST12ZZR	NAST12ZZUUR	12 ⁰ _{-0.008}	32	16	15.8	25.5	
15	NAST15ZZ	NAST15ZZUU	NAST15ZZR	NAST15ZZUUR	15 ⁰ _{-0.008}	35	16	15.8	29	
17	NAST17ZZ	NAST17ZZUU	NAST17ZZR	NAST17ZZUUR	17 ⁰ _{-0.010}	40	20	19.8	32.5	
20	NAST20ZZ	NAST20ZZUU	NAST20ZZR	NAST20ZZUUR	20 ⁰ _{-0.010}	47	20	19.8	38	
25	NAST25ZZ	NAST25ZZUU	NAST25ZZR	NAST25ZZUUR	25 ⁰ _{-0.010}	52	20	19.8	43	
30	NAST30ZZ	NAST30ZZUU	NAST30ZZR	NAST30ZZUUR	30 ⁰ _{-0.010}	62	25	24.8	50.5	
35	NAST35ZZ	NAST35ZZUU	NAST35ZZR	NAST35ZZUUR	35 ⁰ _{-0.012}	72	25	24.8	53.5	
40	NAST40ZZ	NAST40ZZUU	NAST40ZZR	NAST40ZZUUR	40 ⁰ _{-0.012}	80	26	25.8	61.5	
45	NAST45ZZ	NAST45ZZUU	NAST45ZZR	NAST45ZZUUR	45 ⁰ _{-0.012}	85	26	25.8	66.5	
50	NAST50ZZ	NAST50ZZUU	NAST50ZZR	NAST50ZZUUR	50 ⁰ _{-0.012}	90	26	25.8	76	

* Without seals, suitable for grease lubrication. In case of oil lubrication, up to 130% of this value shall be permissible, and 70% of this value shall apply for types with seals.

OUTER RINGS TOLERANCE (Outside diameter) (μm)

TYPE	Cylindrical outer ring	Crowned outer ring
NAST6,NAST8,NAST10	0/-9	0/-50
NAST12,NAST15,NAST17,NAST20	0/-11	0/-50
NAST25,NAST30,NAST35,NAST40	0/-13	0/-50
NAST45,NAST50	0/-15	0/-50

NAST..ZZ



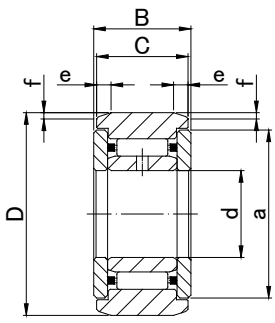

NAST..ZZ

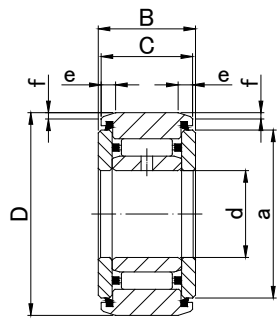

NAST..ZZUU

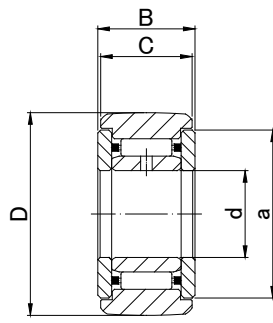

NAST..ZZR

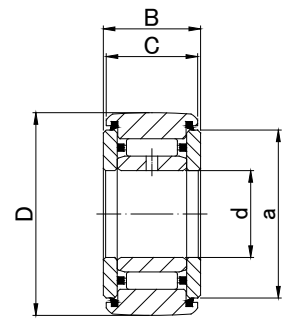

NAST..ZZUUR

Prepacked Grease

			Basic dynamic load rating	Basic static load rating	Track load capacity		Limiting speed *	Mass
e	f	r/s min	Cr N	Cor N	Cylindrical outer ring N	Crowned outer ring N	rpm	g (approx)
2.5	0.8	0.3	4 120	4 550	3 530	1 370	20 000	24.5
2.5	0.8	0.6	5 680	5 890	4 510	1 860	17 000	39
2.5	0.8	1	9 700	9 670	6 860	2 450	15 000	65
2.5	0.8	1	10 400	10 900	7 350	2 740	13 000	75
2.5	0.8	1	12 300	14 300	8 040	3 140	10 000	83
3	1	1	17 400	20 900	11 800	3 720	9 500	135
3	1	1	19 200	24 500	13 800	4 610	8 500	195
3	1	1	20 700	28 400	15 300	5 290	7 000	225
4	1.2	1	30 300	45 400	22 100	6 660	5 500	400
4	1.2	1	32 200	50 600	25 700	8 130	5 000	550
4	1.2	1.5	35 700	61 100	30 300	9 310	4 000	710
4	1.2	1.5	37 100	66 400	31 100	10 100	4 000	760
4	1.2	1.5	38 700	71 800	34 000	11 000	3 500	830

NAST..ZZ



ROLLER FOLLOWERS

NON SEPARABLE WITH INNER RING

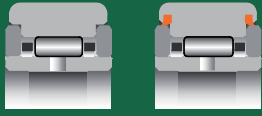

NART..R

NART..VR

NART TYPE

Shaft Diameter (mm)	Designation				Dimensions (mm)					
	Crowned outer ring R500(≤ NART17) R1000(NART20 ≤)		Cylindrical outer ring		d	D	B	C	a	
	Without seals	With seals	Without seals	With seals						
5	NART 5R NART 5VR	NART 5UUR NART 5UUVR	NART 5X NART 5VX	NART 5UUX NART 5UUVX	5 0 5 -0.008	16	12	11	12	
6	NART 6R NART 6VR	NART 6UUR NART 6UUVR	NART 6X NART 6VX	NART 6UUX NART 6UUVX	6 0 6 -0.008	19	12	11	14	
8	NART 8R NART 8VR	NART 8UUR NART 8UUVR	NART 8X NART 8VX	NART 8UUX NART 8UUVX	8 0 8 -0.008	24	15	14	17.5	
10	NART10R NART10VR	NART10UUR NART10UUVR	NART10X NART10VX	NART10UUX NART10UUVX	10 0 10 -0.008	30	15	14	23.5	
12	NART12R NART12VR	NART12UUR NART12UUVR	NART12X NART12VX	NART12UUX NART12UUVX	12 0 12 -0.008	32	15	14	25.5	
15	NART15R NART15VR	NART15UUR NART15UUVR	NART15X NART15VX	NART15UUX NART15UUVX	15 0 15 -0.008	35	19	18	29	
17	NART17R NART17VR	NART17UUR NART17UUVR	NART17X NART17VX	NART17UUX NART17UUVX	17 0 17 -0.008	40	21	20	32.5	
20	NART20R NART20VR	NART20UUR NART20UUVR	NART20X NART20VX	NART20UUX NART20UUVX	20 0 20 -0.010	47	25	24	38	
25	NART25R NART25VR	NART25UUR NART25UUVR	NART25X NART25VX	NART25UUX NART25UUVX	25 0 25 -0.010	52	25	24	43	
30	NART30R NART30VR	NART30UUR NART30UUVR	NART30X NART30VX	NART30UUX NART30UUVX	30 0 30 -0.010	62	29	28	50.5	
35	NART35R NART35VR	NART35UUR NART35UUVR	NART35X NART35VX	NART35UUX NART35UUVX	35 0 35 -0.012	72	29	28	53.5	
40	NART40R NART40VR	NART40UUR NART40UUVR	NART40X NART40VX	NART40UUX NART40UUVX	40 0 40 -0.012	80	32	30	61.5	
45	NART45R NART45VR	NART45UUR NART45UUVR	NART45X NART45VX	NART45UUX NART45UUVX	45 0 45 -0.012	85	32	30	66.5	
50	NART50R NART50VR	NART50UUR NART50UUVR	NART50X NART50VX	NART50UUX NART50UUVX	50 0 50 -0.012	90	32	30	76	

* Without seals, suitable for grease lubrication. In case of oil lubrication, up to 130% of this value shall be permissible, and 70% of this value shall apply for types with seals.

OUTER RINGS TOLERANCE (Outside diameter) (μm)

TYPE	Crowned outer ring	Cylindrical outer ring
NART5	0/-50	0/-8
NART6,NART8,NART10	0/-50	0/-9
NART12,NART15,NART17,NART20	0/-50	0/-11
NART25,NART30,NART35,NART40	0/-50	0/-13
NART45,NART50	0/-50	0/-15

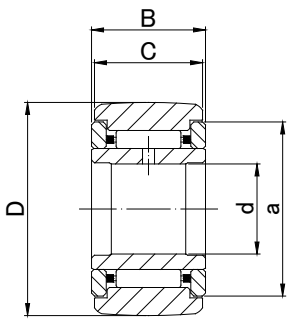

NART..R
NART..X

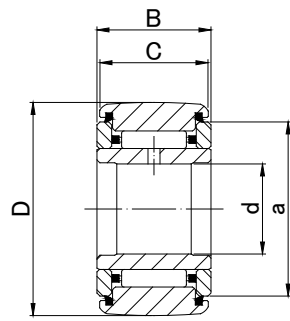

NART..UUR
NART..UUX

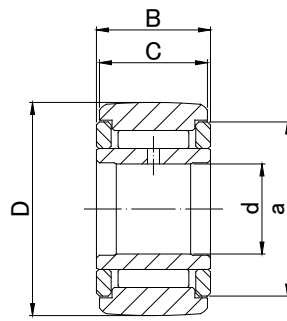



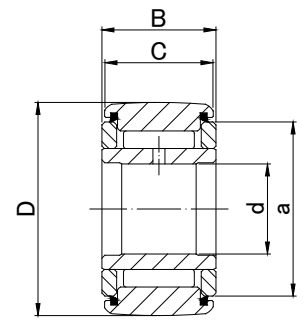



NART..VR
NART..VX



NART..UUVR
NART..UUVX

Prepacked Grease

f's min	Basic dynamic load rating	Basic static load rating	Track load capacity		Limiting speed *	Mass
						
	Cr N	Cor N	Crowned outer ring N	Cylindrical outer ring N	rpm	g (approx)
0.3	3 620 6 760	3 720 8 340	1 080	3 430	25 000 8 500	14.5 15.1
0.3	4 200 7 640	4 700 10 300	1 370	4 020	20 000 7 000	20.5 21.5
0.3	6 600 11 800	7 300 15 600	1 860	5 950	17 000 5 500	41.5 42.5
0.6	8 600 15 600	8 300 18 100	2 450	7 060	15 000 5 000	64.5 66.5
0.6	9 100 16 800	9 200 20 500	2 740	7 450	13 000 4 500	71 73
0.6	14 400 25 100	17 600 36 400	3 140	11 200	10 000 3 500	102 106
1	18 600 32 000	22 500 46 200	3 720	14 400	9 500 3 000	149 155
1	24 100 41 700	32 700 67 300	7 150	21 000	8 000 2 500	250 255
1	25 800 45 500	37 500 79 000	8 230	23 200	7 000 2 500	285 295
1	36 200 59 800	56 900 110 400	10 500	33 000	5 500 1 800	470 485
1	38 200 63 000	62 800 121 500	12 900	38 000	5 000 1 700	640 655
1	46 200 76 200	84 700 164 200	14 900	44 400	4 000 1 400	845 865
1	49 300 80 200	95 200 181 100	16 100	47 000	4 000 1 300	915 935
1	51 100 84 100	102 300 198 000	17 300	50 000	3 500 1 200	980 1 010

NART



ROLLER FOLLOWERS

FULL COMPLEMENT DOUBLE ROW
NON SEPARABLE
WITH INNER RING



NURT

NURT TYPE

Shaft Diameter (mm)	Designation		Dimensions (mm)					
	Crowned outer ring R500(\leq NURT17-1) R1000(NURT20 \leq)	Cylindrical outer ring	d	D	B	C	a	
15	NURT15R	NURT15X	15 ⁰	35	19	18	20	
	NURT15-1R	NURT15-1X	15 ^{-0.008}	42	19	18	20	
17	NURT17R	NURT17X	17 ⁰	40	21	20	22	
	NURT17-1R	NURT17-1X	17 ^{-0.008}	47	21	20	22	
20	NURT20R	NURT20X	20 ⁰	47	25	24	27	
	NURT20-1R	NURT20-1X	20 ^{-0.010}	52	25	24	27	
25	NURT25R	NURT25X	25 ⁰	52	25	24	31	
	NURT25-1R	NURT25-1X	25 ^{-0.010}	62	25	24	31	
30	NURT30R	NURT30X	30 ⁰	62	29	28	38	
	NURT30-1R	NURT30-1X	30 ^{-0.010}	72	29	28	38	
35	NURT35R	NURT35X	35 ⁰	72	29	28	44	
	NURT35-1R	NURT35-1X	35 ^{-0.012}	80	29	28	44	
40	NURT40R	NURT40X	40 ⁰	80	32	30	51	
	NURT40-1R	NURT40-1X	40 ^{-0.012}	90	32	30	51	
45	NURT45R	NURT45X	45 ⁰	85	32	30	55	
	NURT45-1R	NURT45-1X	45 ^{-0.012}	100	32	30	55	
50	NURT50R	NURT50X	50 ⁰	90	32	30	60	
	NURT50-1R	NURT50-1X	50 ^{-0.012}	110	32	30	60	

OUTER RINGS TOLERANCE (Outside diameter) (μm)

TYPE	Crowned outer ring	Cylindrical outer ring
NURT15, NURT15-1, NURT17, NURT17-1, NURT20	0/-50	0/-11
NURT20-1, NURT25, NURT25-1, NURT30, NURT30-1, NURT35, NURT35-1, NURT40	0/-50	0/-13
NURT40-1, NURT45, NURT45-1, NURT50, NURT50-1	0/-50	0/-15



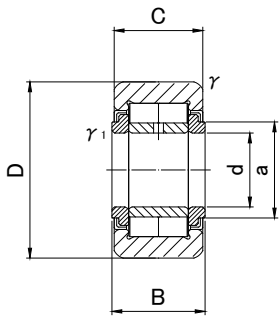

NURT..R
NURT..X

Prepacked Grease

		Basic dynamic load rating	Basic static load rating	Track load capacity		Limiting speed	Mass
r/s min	$r1/s$ min	Cr N	Cor N	Crowned outer ring N	Cylindrical outer ring N	rpm	g (approx)
0.6	0.3	23 400	27 200	3 140	11 200	5 200	100
0.6	0.3	23 400	27 200	3 930	13 900	5 200	160
1	0.5	25 200	30 900	3 720	14 400	4 700	147
1	0.5	25 200	30 900	4 550	17 300	4 700	222
1	0.5	38 900	48 900	7 150	21 000	3 800	245
1	0.5	38 900	48 900	8 230	23 200	3 800	321
1	0.5	43 000	58 100	8 230	23 200	3 300	281
1	0.5	43 000	58 100	10 500	27 400	3 300	450
1	0.5	57 500	74 300	10 500	32 000	2 800	466
1	0.5	57 500	74 300	12 900	37 200	2 800	697
1.1	0.6	63 300	87 500	12 900	37 200	2 300	630
1.1	0.6	63 300	87 500	14 900	41 300	2 300	840
1.1	0.6	86 900	124 600	14 900	44 300	1 900	817
1.1	0.6	86 900	124 600	17 300	49 800	1 900	1 130
1.1	0.6	91 700	137 100	16 100	47 100	1 700	883
1.1	0.6	91 700	137 100	19 840	55 400	1 700	1 400
1.1	0.6	96 300	149 700	17 300	49 800	1 500	950
1.1	0.6	96 300	149 700	22 530	60 900	1 500	1 690



NEEDLE ROLLER BEARINGS

STAINLESS STEEL



MACHINED RING NEEDLE ROLLER BEARINGS STAINLESS STEEL WITHOUT INNER RING

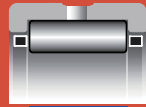

SUS/INOX



RNA49..M , NK..M

RNA49..M NK..M TYPE

Shaft Diameter (mm)	Designation		Dimensions (mm)			
	RNA49..M	NK..M	Fw	D	C	r _s min
5	— —	NK5/10M NK5/12M	5 +0.018 5 +0.010	10 10	10 12	0.15 0.15
6	— —	NK6/10M NK6/12M	6 +0.018 6 +0.010	12 12	10 12	0.015 0.15
7	RNA495M — —	— NK7/10M NK7/12M	7 +0.022 7 +0.013 7 —	13 14 14	10 10 12	0.15 0.3 0.3
8	RNA496M — —	— NK8/12M NK8/16M	8 +0.022 8 +0.013 8	15 15 15	10 12 16	0.15 0.3 0.3
9	— — RNA497M	NK9/12M NK9/16M —	9 +0.022 9 +0.013 9	16 16 17	12 16 10	0.3 0.3 0.15
10	— — RNA498M	NK10/12M NK10/16M —	10 +0.022 10 +0.013 10	17 17 19	12 16 11	0.3 0.3 0.2
12	— — RNA499M	NK12/12M NK12/16M —	12 +0.027 12 +0.016 12	19 19 20	12 16 11	0.3 0.3 0.3
14	RNA4900M — —	— NK14/16M NK14/20M	14 +0.027 14 +0.016 14	22 22 22	13 16 20	0.3 0.3 0.3
15	— —	NK15/16M NK15/20M	15 +0.027 15 +0.016	23 23	16 20	0.3 0.3

RNA..M NK..M



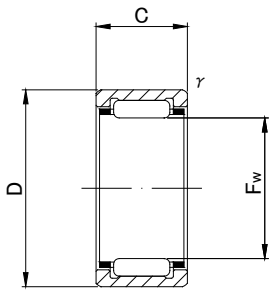

NK..M(Fw ≤ 10)

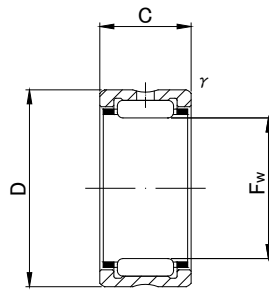

RNA49..M,NK..M

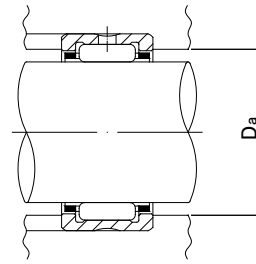

Standard mounting dimensions (mm)	Basic dynamic load rating	Basic static load rating	Limiting speed *	Mass	Usable bearing designation	
					INNER RING	WITH INNER RING
Da MAX	Cr N	Cor N	rpm	g (approx)	INNER RING	WITH INNER RING
6.5	2 200	1 700	40 000	3.4	—	—
6.5	2 800	2 400	40 000	4.2	—	—
7.5	2 400	2 100	37 000	5.3	—	—
7.5	3 100	2 900	37 000	6.4	—	—
8.5	2 700	2 400	34 000	5.9	—	—
8.5	3 300	2 700	34 000	6.9	—	—
8.5	4 200	3 700	34 000	8.3	—	—
13.8	3 500	3 100	32 000	7.3	IR6810M	NA496M
13	4 600	4 300	32 000	9	IR5812M	NKI 5/12M
13	6 500	6 700	32 000	13	IR5816M	NKI 5/16M
14	5 000	4 800	30 000	10	IR6912M	NKI 6/12M
14	6 900	7 500	30 000	13.2	IR6916M	NKI 6/16M
15.8	4 100	3 300	30 000	9.3	IR7910M	NA497M
15	5 400	5 500	28 000	10.7	IR71012M	NKI 7/12M
15	7 500	8 400	28 000	14.3	IR71016M	NKI 7/16M
17.4	5 700	4 600	28 000	12.6	IR81011M	NA498M
17	6 000	6 700	26 000	12.2	IR91212M	NKI 9/12M
17	8 400	10 300	26 000	16.3	IR91216M	NKI 9/16M
18	6 000	5 700	26 000	13.6	IR91211M	NA499M
20	8 400	9 200	24 000	16.5	IR101413M	NA4900M
20	10 800	12 600	24 000	21	IR101416M	NKI 10/16
20	13 600	17 000	24 000	26.5	IR101420M	NKI 10/20
21	11 400	13 700	23 000	22.5	—	—
21	14 300	18 500	23 000	28	—	—

* Suitable for oil lubrication. In case of grease lubrication, down to 60% of this value.

RNA..M NK..M



MACHINED RING NEEDLE ROLLER BEARINGS STAINLESS STEEL WITHOUT INNER RING

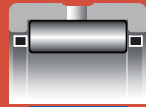

SUS/INOX



RNA49..M , NK..M

RNA49..M NK..M TYPE

Shaft Diameter (mm)	Designation		Dimensions (mm)			
	RNA49..M	NK..M	Fw	D	C	f's min
16	RNA4901M	—	16	24	13	0.3
	—	NK16/16M	16 +0.027	24	16	0.3
	—	NK16/20M	16 +0.016	24	20	0.3
17	—	NK17/16M	17 +0.027	25	16	0.3
	—	NK17/20M	17 +0.016	25	20	0.3
18	—	NK18/16M	18 +0.027	26	16	0.3
	—	NK18/20M	18 +0.016	26	20	0.3
19	—	NK19/16M	19 +0.033	27	16	0.3
	—	NK19/20M	19 +0.020	27	20	0.3
20	RNA4902M	—	20 +0.033 +0.020	28	13	0.3
22	RNA4903M	—	22 +0.033 +0.020	30	13	0.3
25	RNA4904M	—	25 +0.033 +0.020	37	17	0.3
30	RNA4905M	—	30 +0.033 +0.020	42	17	0.3

RNA..M NK..M



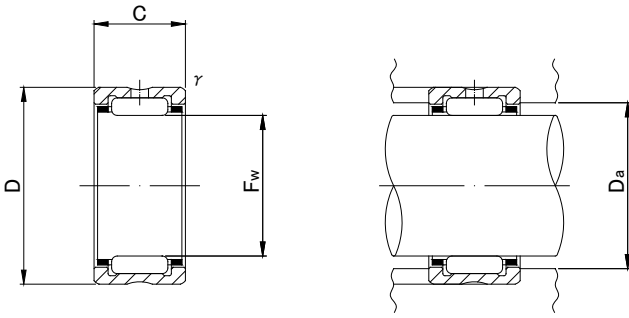

RNA49..M,NK..M

Standard mounting dimensions (mm)	Basic dynamic load rating	Basic static load rating	Limiting speed *	Mass	Usable bearing designation	
					INNER RING	WITH INNER RING
Da MAX	Cr N	Cor N	rpm	g (approx)		
22 22 22	8 900 11 300 14 300	10 200 13 800 18 700	23 000 23 000 23 000	18.1 23 29	IR121613M IR121616M IR121620M	NA4901M NKI 12/16M NKI 12/20M
23 23	11 700 14 900	14 900 20 300	22 000 22 000	24.5 30.5	— —	— —
24 24	12 300 15 600	16 100 21 700	21 000 21 000	25.5 32	— —	— —
25 25	12 800 16 200	17 200 23 200	21 000 21 000	27 34	IR151916M IR151920M	NKI 15/16M NKI 15/20M
26	10 000	12 600	20 000	21.5	IR152013M	NA4902M
28	10 800	14 300	18 000	23.5	IR172213M	NA4903M
35	19 300	23 000	16 000	55.5	IR202517M	NA4904M
40	21 800	28 200	13 000	64	IR253017M	NA4905M

* Suitable for oil lubrication. In case of grease lubrication, down to 60% of this value.

RNA..M NK..M



MACHINED RING NEEDLE ROLLER BEARINGS STAINLESS STEEL

WITH INNER RING

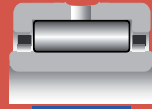

SUS/INOX



NA49..M ,NKI..M

NA49..M ,NKI..M TYPE

Shaft Diameter (mm)	Designation		Dimensions (mm)				
	NA49..M	NKI..M	d	D	C	r _s min	F
5	NA495M	—	5	13	10	0.15	7
	—	NKI 5/12M	5 ⁰ _{-0.008}	15	12	0.3	8
	—	NKI 5/16M	5	15	16	0.3	8
6	NA496M	—	6	15	10	0.15	8
	—	NKI 6/12M	6 ⁰ _{-0.008}	16	12	0.3	9
	—	NKI 6/16M	6	16	16	0.3	9
7	NA497M	—	7	17	10	0.15	9
	—	NKI 7/12M	7 ⁰ _{-0.008}	17	12	0.3	10
	—	NKI 7/16M	7	17	16	0.3	10
8	NA498M	—	8 ⁰ _{-0.008}	19	11	0.2	10
9	—	NKI 9/12M	9	19	12	0.3	12
	—	NKI 9/16M	9 ⁰ _{-0.008}	19	16	0.3	12
	NA499M	—	9	20	11	0.3	12
10	NA4900M	—	10	22	13	0.3	14
	—	NKI 10/16M	10 ⁰ _{-0.008}	22	16	0.3	14
	—	NKI 10/20M	10	22	20	0.3	14
12	NA4901M	—	12	24	13	0.3	16
	—	NKI 12/16M	12 ⁰ _{-0.008}	24	16	0.3	16
	—	NKI 12/20M	12	24	20	0.3	16
15	—	NKI 15/16M	15	27	16	0.3	19
	—	NKI 15/20M	15 ⁰ _{-0.008}	27	20	0.3	19
	NA4902M	—	15	28	13	0.3	20
17	NA4903M	—	17 ⁰ _{-0.008}	30	13	0.3	22
20	NA4904M	—	20 ⁰ _{-0.010}	37	17	0.3	25
25	NA4905M	—	25 ⁰ _{-0.010}	42	17	0.3	30

NA..M ,NKI..M



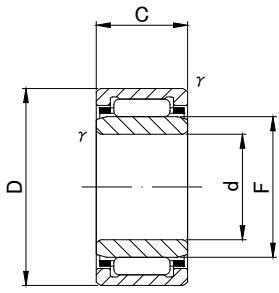

NKI..M($d \leq 8$)

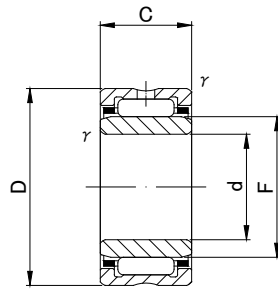

NA49..M,NKI..M

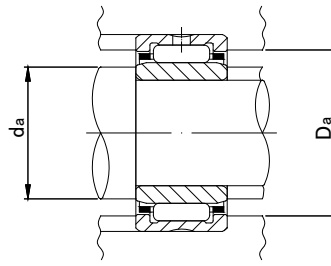

Standard mounting dimensions (mm)			Basic dynamic load rating	Basic static load rating	Limiting speed *	Mass	Usable bearing designation	
da		Da MAX	Cr N	Cor N	rpm	g (approx)	OUTER RING	INNER RING
MIN	MAX							
6.2	6.7	11.8	2 700	2 400	34 000	7.3	RNA495M	IR5710M
7	7.7	13	4 600	4 300	32 000	11.9	NK8/12M	IR5812M
7	7.7	13	6 500	6 700	32 000	16.7	NK8/16M	IR5816M
7.2	7.7	13.8	3 500	3 100	32 000	9.1	RNA496M	IR6810M
8	8.7	14	5 000	4 800	30 000	13	NK9/12M	IR6912M
8	8.7	14	6 900	7 500	30 000	17.5	NK9/16M	IR6916M
8.2	8.7	15.8	4 100	3 300	30 000	11.2	RNA497M	IR7910M
9	9.7	15	5 400	5 500	28 000	14.3	NK10/12M	IR71012M
9	9.7	15	7 500	8 400	28 000	19.2	NK10/16M	IR71016M
9.2	9.7	17.4	5 700	4 600	28 000	15	RNA498M	IR81011M
11	11.5	17	6 000	6 700	26 000	16.7	NK12/12M	IR91212M
11	11.5	17	8 400	10 300	26 000	22.5	NK12/16M	IR91216M
11	11.5	18	6 000	5 700	26 000	16.7	RNA499M	IR91211M
12	13	20	8 400	9 200	24 000	24	RNA4900M	IR101413M
12	13	20	10 800	12 600	24 000	30	NK14/16M	IR101416M
12	13	20	13 600	17 000	24 000	38	NK14/20M	IR101420M
14	15	22	8 900	10 200	23 000	26.5	RNA4901M	IR121613M
14	15	22	11 300	13 800	23 000	33.5	NK16/16M	IR121616M
14	15	22	14 300	18 700	23 000	42.5	NK16/20M	IR121620M
17	18	25	12 800	17 200	21 000	39.5	NK19/16M	IR151916M
17	18	25	16 200	23 200	21 000	50	NK19/20M	IR151920M
17	19	26	10 000	12 600	20 000	35	RNA4902M	IR152013M
19	21	28	10 800	14 300	18 000	39	RNA4903M	IR172213M
22	24	35	19 300	23 000	16 000	78.5	RNA4904M	IR202517M
27	29	40	21 800	28 200	13 000	92.5	RNA4905M	IR253017M

* Suitable for oil lubrication. In case of grease lubrication, down to 60% of this value.

NA..M, NKI..M



INNER RINGS STAINLESS STEEL



SUS/INOX



IR..M

IR..M TYPE



Shaft Diameter (mm)	Designation	Dimensions (mm)				Standard mounting dimensions (mm)	
		d	F	B	f/s min	da	
						MIN	MAX
5	IR 5710M	5 ⁰	7	10	0.15	6.2	6.7
	IR 5812M	5 ^{-0.008}	8	12	0.3	7	7.7
	IR 5816M	5	8	16	0.3	7	7.7
6	IR 6810M	6 ⁰	8	10	0.15	7.2	7.7
	IR 6912M	6 ^{-0.008}	9	12	0.3	8	8.7
	IR 6916M	6	9	16	0.3	8	8.7
	IR 61010M	6	10	10	0.3	8	9.7
7	IR 7910M	7 ⁰	9	10	0.15	8.2	8.7
	IR 71012M	7 ^{-0.008}	10	12	0.3	9	9.7
	IR 71016M	7	10	16	0.3	9	9.7
8	IR 81011M	8 ⁰	10	11	0.15	9.2	9.7
	IR 81210M	8 ^{-0.008}	12	10	0.3	10	11
9	IR 91211M	9 ⁰	12	11	0.3	11	11.5
	IR 91212M	9 ^{-0.008}	12	12	0.3	11	11.5
	IR 91216M	9	12	16	0.3	11	11.5
10	IR 101412M	10 ⁰	14	12	0.3	12	13
	IR 101413M	10 ^{-0.008}	14	13	0.3	12	13
	IR 101416M	10	14	16	0.3	12	13
	IR 101420M	10	14	20	0.3	12	13
12	IR 121612M	12 ⁰	16	12	0.3	14	15
	IR 121613M	12 ^{-0.008}	16	13	0.3	14	15
	IR 121616M	12	16	16	0.3	14	15
	IR 121620M	12	16	20	0.3	14	15
15	IR 151916M	15 ⁰	19	16	0.3	17	18
	IR 151920M	15 ^{-0.008}	19	20	0.3	17	18
	IR 152012M	15	20	12	0.3	17	19
	IR 152013M	15	20	13	0.3	17	19
17	IR 172213M	17 ⁰	22	13	0.3	19	21
	IR 172216M	17 ^{-0.008}	22	16	0.3	19	21

IR..M

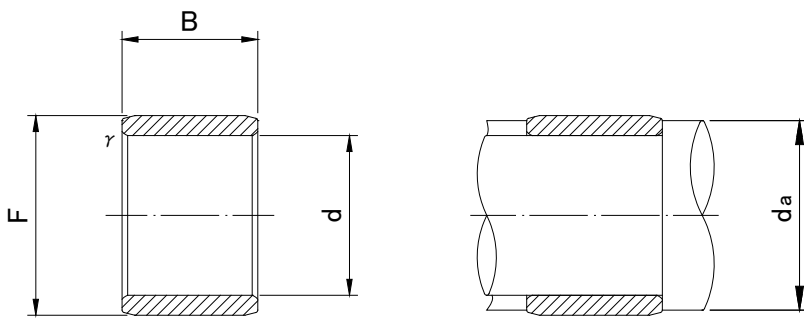



IR..M

Mass	Usable bearing designation	
		
g (approx)	RNA49..M	NK..M
1.4	RNA495M	—
3	—	NK8/12M
4	—	NK8/16M
1.7	RNA496M	—
3.2	—	NK9/12M
4.3	—	NK9/16M
4	—	—
1.9	RNA497M	—
3.6	—	NK10/12M
5	—	NK10/16M
2.4	RNA498M	—
4.8	—	—
3.1	RNA499M	—
4.5	—	NK12/12M
6	—	NK12/16M
7	—	—
7.5	RNA4900M	—
9	—	NK14/16M
11.5	—	NK14/20M
8	—	—
8.5	RNA4901M	—
10.5	—	NK16/16M
13.5	—	NK16/20M
12.5	—	NK19/16M
16	—	NK19/20M
12	—	—
13.5	RNA4902M	—
15.5	RNA4903M	—
19	—	—

IR..M



INNER RINGS STAINLESS STEEL



SUS/INOX



IR..M

IR..M TYPE



Shaft Diameter (mm)	Designation	Dimensions (mm)				Standard mounting dimensions (mm)	
		IR..M	d	F	B	r's min	MIN
20	IR 202516M	20 ⁰	25	16	0.3	22	24
	IR 202517M	20 ^{-0.010}	25	17	0.3	22	24
25	IR 253016M	25 ⁰	30	16	0.3	27	29
	IR253017M	25 ^{-0.010}	30	17	0.3	27	29
30	IR 303820M	30 ⁰	38	20	0.6	34	37
35	IR 354220M	35 ⁰	42	20	0.6	39	41
50	IR 506020M	50 ⁰	60	20	1	55	59

IR..M

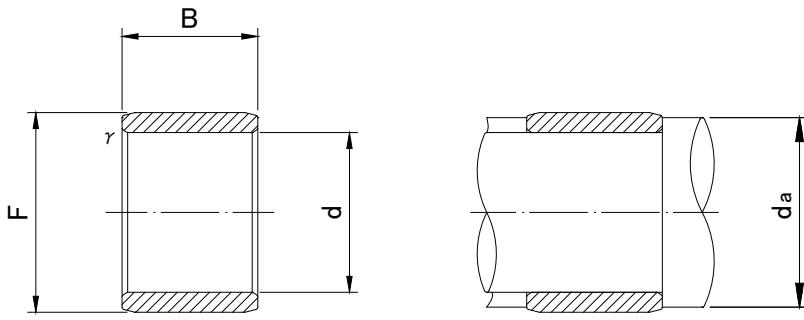



IR..M

Mass 	Usable bearing designation 	
g (approx)	RNA49..M	NK..M
22 23	— RNA4904M	— —
28 28.5	— RNA4905M	— —
65	—	—
65	—	—
135	—	—

IR..M



CAM FOLLOWERS

STAINLESS STEEL



CAM FOLLOWERS STAINLESS STEEL

MINIATURE TYPE
HEXAGON SOCKET ON STUD HEAD

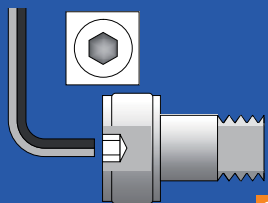

SUS/INOX



CFS..MA



CFS..VMA

CFS..MA TYPE





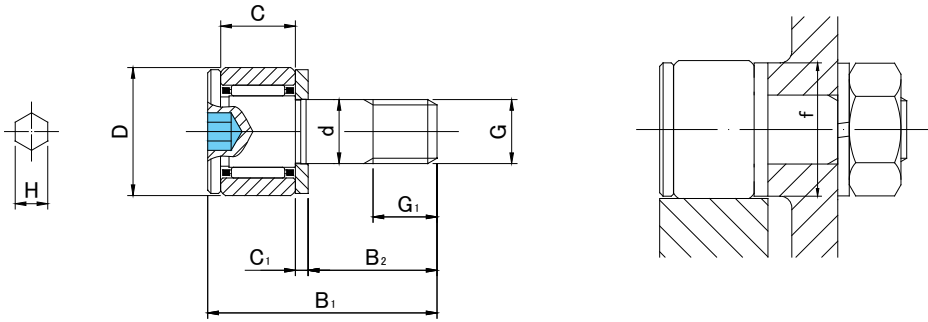

Stud diameter (mm)	Designation	Dimensions (mm)											
		Cylindrical outer ring		D		C	d	G	G1	B1	B2	C1	H
h6 tolerance	With cage	Full roller											
2.5	CFS 2.5MA	—	5	3	2.5	M2.5×0.45	2.5	9.5	5	0.7	0.9		
	—	CFS 2.5VMA											
3	CFS 3MA	—	6	4	3	M3×0.5	3	11.5	6	0.7	1.5		
	—	CFS 3VMA											
4	CFS 4MA	—	8	5	4	M4×0.7	4	15	8	1	2		
	—	CFS 4VMA											
5	CFS 5MA	—	10	6	5	M5×0.8	5	18	10	1	2.5		
	—	CFS 5VMA											
6	CFS 6MA	—	12	7	6	M6×1	6	21.5	12	1.2	3		
	—	CFS 6VMA											

OUTER RINGS TOLERANCE (μm)

TYPE	Cylindrical outer ring
CFS2.5M,CFS3M,CFS4M,CFS5M,CFS6M	0/-8



Prepacked Grease

	Basic dynamic load rating	Basic static load rating	Largest permissible load	Max tightening torque	Mass
					
f min	Cr N	Cor N	N	N·m	g (approx)
4.8	370	300	260	0.2	1
	920	990	260		
5.8	570	560	360	0.3	2
	1 260	1 620	360		
7.7	990	990	780	0.6	4
	2 160	2 790	780		
9.6	1 440	1 710	1 420	1.3	7
	2 880	4 330	1 420		
11.6	1 890	1 980	2 110	2.3	13
	4 240	5 760	2 110		

ACCESSORIES

TYPE	
All types	NUT Attached



CAM FOLLOWERS STAINLESS STEEL HEXAGON SOCKET ON STUD HEAD

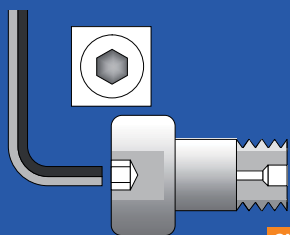

SUS/INOX



CF..MA



CF..VMA

CF..MA TYPE

Stud diameter (mm)	h7 tolerance	Designation				Dimensions (mm)							
		Cylindrical outer ring		Crowned outer ring R250(CF3 ~ CF5) R500(CF6 ~ CF10-1)		D	C	d	G	G1	B1	B2	
		Without seals	With seals	Without seals	With seals								
3	0 -0.010	CF 3MA	CF 3MUUA	CF 3MRA	CF 3MUURA	10	7	3	M3×0.5	5	17	9	
		CF 3VMA	CF 3VMUUA	CF 3VMRA	CF 3VMUURA								
4	0 -0.012	CF 4MA	CF 4MUUA	CF 4MRA	CF 4MUURA	12	8	4	M4×0.7	6	20	11	
		CF 4VMA	CF 4VMUUA	CF 4VMRA	CF 4VMUURA								
5	0 -0.012	CF 5MA	CF 5MUUA	CF 5MRA	CF 5MUURA	13	9	5	M5×0.8	7.5	23	13	
		CF 5VMA	CF 5VMUUA	CF 5VMRA	CF 5VMUURA								
6	0 -0.012	CF 6MA	CF 6MUUA	CF 6MRA	CF 6MUURA	16	11	6	M6×1	8	28	16	
		CF 6VMA	CF 6VMUUA	CF 6VMRA	CF 6VMUURA								
8	0 -0.015	CF 8MA	CF 8MUUA	CF 8MRA	CF 8MUURA	19	11	8	M8×1.25	10	32	20	
		CF 8VMA	CF 8VMUUA	CF 8VMRA	CF 8VMUURA								
10	0 -0.015	CF10MA	CF10MUUA	CF10MRA	CF10MUURA	22	12	10	M10×1.25	12	36	23	
		CF10VMA	CF10VMUUA	CF10VMRA	CF10VMUURA								
10	0 -0.015	CF10-1MA	CF10-1MUUA	CF10-1MRA	CF10-1MUURA	26	12	10	M10×1.25	12	36	23	
		CF10-1VMA	CF10-1VMUUA	CF10-1VMRA	CF10-1VMUURA								
10	0 -0.015	CF10MAK	CF10MUUAK	CF10MRAK	CF10MUURAK	22	12	10	M10×1	12	36	23	
		CF10VMAK	CF10VMUAK	CF10VMRAK	CF10VMUURAK								
10	0 -0.015	CF10-1MAK	CF10-1MUAK	CF10-1MRAK	CF10-1MUURAK	26	12	10	M10×1	12	36	23	
		CF10-1VMAK	CF10-1VMUAK	CF10-1VMRAK	CF10-1VMUURAK								

* Without seals, suitable for grease lubrication. In case of oil lubrication, up to 130% of this value shall be permissible, and 70% of this value shall apply for types with seals.

OUTER RINGS TOLERANCE (μm)

TYPE	Cylindrical outer ring	Crowned outer ring
CF3M,CF4M,CF5M,CF6M	0/-8	0/-50
CF8M,CF10M,CF10-1M,CF12M	0/-9	0/-50
CF12-1M,CF16M,CF18M,CF20-1M	0/-11	0/-50
CF20M,CF24M,CF24-1M,CF30M	0/-13	0/-50
CF30-1M,CF30-2M	0/-15	0/-50

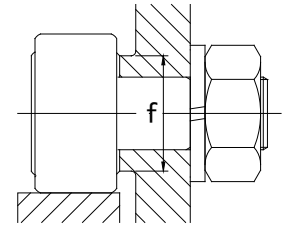
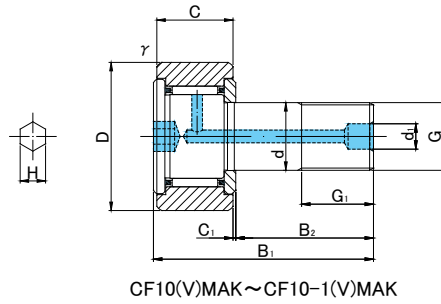
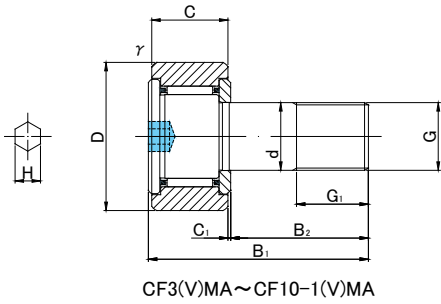

Prepacked Grease

							Basic dynamic load rating	Basic static load rating	Largest permissible load	Limiting speed *	Track load capacity		Max tightening torque	Mass
B3	C1	d1	d2	H	r/s min	f min	Cr N	Cor N	N	rpm	Cylindrical outer ring N	Crowned outer ring N	N·m	g (approx)
—	0.5	—	—	1.5	0.2	6.8	1 350	1 080	360	47 000	1 370	540	0.4	4.5
							2 570	2 300	360	18 800				
—	0.5	—	—	2	0.3	8.6	1 890	1 880	780	37 000	1 760	690	1	7.5
							3 680	3 950	780	14 800				
—	0.5	—	—	2.5	0.3	9.7	2 880	2 540	1 420	29 000	2 250	780	2	10.5
							4 690	5 060	1 420	11 600				
—	0.6	—	—	3	0.3	11	3 330	3 330	2 110	25 000	3 430	1 080	3	18.5
							6 400	7 840	2 110	12 000				
—	0.6	—	—	4	0.3	13	3 960	4 330	4 710	20 000	4 020	1 370	8	28.5
							7 470	10 270	4 710	9 000				
—	0.6	—	—	5	0.3	15	4 950	6 310	6 860	17 000	4 700	1 670	15	45
							8 740	13 340	7 450	7 500				
—	0.6	—	—	5	0.3	15	4 950	6 310	6 860	17 000	5 490	2 060	15	60
							8 740	13 340	7 450	7 500				
—	0.6	4	—	5	0.3	15	4 950	6 310	6 860	17 000	4 700	1 670	15	45
							8 740	13 340	7 450	7 500				
—	0.6	4	—	5	0.3	15	4 950	6 310	6 860	17 000	5 490	2 060	15	60
							8 740	13 340	7 450	7 500				

CF..MA



ACCESSORIES

TYPE			
CF3M/CF4M/CF5M/CF6M/CF8M/CF10M/CF10-1M	—	—	Attached
CF10MK/CF10-1MK	φ 4 Attached	φ 4 Attached	Attached
CF12M/CF12-1M/CF16M/CF18M	φ 6 Attached	φ 6 Attached	Attached
CF20M/CF20-1M/CF24M/CF24-1M/CF30M/CF30-1M/CF30-2M	φ 8 Attached	φ 8 Attached	Attached

CAM FOLLOWERS STAINLESS STEEL HEXAGON SOCKET ON STUD HEAD

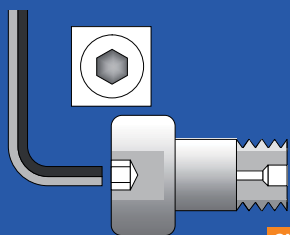

SUS/INOX



CF..MA



CF..VMA

CF..MA TYPE

Stud diameter (mm)	h7 tolerance	Designation				Dimensions (mm)						
		Cylindrical outer ring		Crowned outer ring R500(CF12 ~ CF18) R1000(CF20 ≤)		D	C	d	G	G1	B1	B2
		Without seals	With seals	Without seals	With seals							
12	0 -0.018	CF12MA	CF12MUUA	CF12MRA	CF12MUURA	30	14	12	M12×1.5	13	40	25
		CF12VMA	CF12VMUUA	CF12VMRA	CF12VMUURA							
12	0 -0.018	CF12-1MA	CF12-1MUUA	CF12-1MRA	CF12-1MUURA	32	14	12	M12×1.5	13	40	25
		CF12-1VMA	CF12-1VMUUA	CF12-1VMRA	CF12-1VMUURA							
16	0 -0.018	CF16MA	CF16MUUA	CF16MRA	CF16MUURA	35	18	16	M16×1.5	17	52	32.5
		CF16VMA	CF16VMUUA	CF16VMRA	CF16VMUURA							
18	0 -0.018	CF18MA	CF18MUUA	CF18MRA	CF18MUURA	40	20	18	M18×1.5	19	58	36.5
		CF18VMA	CF18VMUUA	CF18VMRA	CF18VMUURA							
20	0 -0.021	CF20MA	CF20MUUA	CF20MRA	CF20MUURA	52	24	20	M20×1.5	21	66	40.5
		CF20VMA	CF20VMUUA	CF20VMRA	CF20VMUURA							
20	0 -0.021	CF20-1MA	CF20-1MUUA	CF20-1MRA	CF20-1MUURA	47	24	20	M20×1.5	21	66	40.5
		CF20-1VMA	CF20-1VMUUA	CF20-1VMRA	CF20-1VMUURA							
24	0 -0.021	CF24MA	CF24MUUA	CF24MRA	CF24MUURA	62	29	24	M24×1.5	25	80	49.5
		CF24VMA	CF24VMUUA	CF24VMRA	CF24VMUURA							
24	0 -0.021	CF24-1MA	CF24-1MUUA	CF24-1MRA	CF24-1MUURA	72	29	24	M24×1.5	25	80	49.5
		CF24-1VMA	CF24-1VMUUA	CF24-1VMRA	CF24-1VMUURA							
30	0 -0.021	CF30MA	CF30MUUA	CF30MRA	CF30MUURA	80	35	30	M30×1.5	32	100	63
		CF30VMA	CF30VMUUA	CF30VMRA	CF30VMUURA							
30	0 -0.021	CF30-1MA	CF30-1MUUA	CF30-1MRA	CF30-1MUURA	85	35	30	M30×1.5	32	100	63
		CF30-1VMA	CF30-1VMUUA	CF30-1VMRA	CF30-1VMUURA							
30	0 -0.021	CF30-2MA	CF30-2MUUA	CF30-2MRA	CF30-2MUURA	90	35	30	M30×1.5	32	100	63
		CF30-2VMA	CF30-2VMUUA	CF30-2VMRA	CF30-2VMUURA							

* Without seals, suitable for grease lubrication. In case of oil lubrication, up to 130% of this value shall be permissible, and 70% of this value shall apply for types with seals.

OUTER RINGS TOLERANCE (μm)

TYPE	Cylindrical outer ring	Crowned outer ring
CF3M,CF4M,CF5M,CF6M	0/-8	0/-50
CF8M,CF10M,CF10-1M,CF12M	0/-9	0/-50
CF12-1M,CF16M,CF18M,CF20-1M	0/-11	0/-50
CF20M,CF24M,CF24-1M,CF30M	0/-13	0/-50
CF30-1M,CF30-2M	0/-15	0/-50



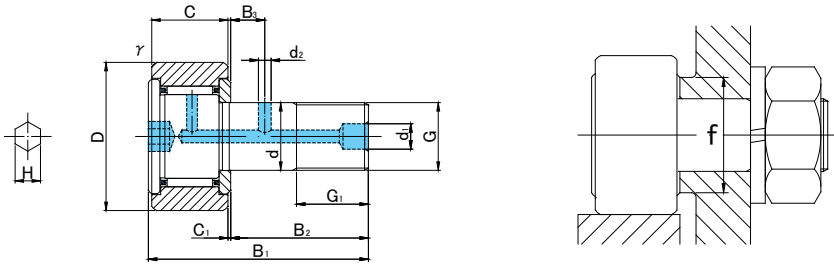

Prepacked Grease

							Basic dynamic load rating	Basic static load rating	Largest permissible load	Limiting speed *	Track load capacity		Max tightening torque	Mass
B3	C1	d1	d2	H	r/s min	f min	Cr N	Cor N	N	rpm	Cylindrical outer ring N	Crowned outer ring N	N·m	g (approx)
6	0.6	6	3	6	0.6	20	7 300	9 010	9 800	14 000	7 060	2 450	22	95
							12 350	18 120	11 270	6 000				
6	0.6	6	3	6	0.6	20	7 300	9 010	9 800	14 000	7 450	2 740	22	105
							12 350	18 120	11 270	6 000				
8	0.8	6	3	6	0.6	24	11 080	16 860	18 330	10 000	11 200	3 140	58	170
							19 020	34 610	19 800	4 500				
8	0.8	6	3	6	1	26	13 520	23 180	25 200	8 500	14 400	3 720	87	250
							23 250	47 240	26 560	3 500				
9	0.8	8	4	8	1	36	19 020	31 830	32 140	7 000	23 200	8 230	120	460
							30 470	59 320	32 140	3 500				
9	0.8	8	4	8	1	36	19 020	31 830	32 140	7 000	21 000	7 150	120	385
							30 470	59 320	32 140	3 500				
11	0.8	8	4	8	1	40	28 040	48 410	49 500	6 500	34 200	10 500	220	815
							42 820	84 650	49 500	3 000				
11	0.8	8	4	8	1	40	28 040	48 410	49 500	6 500	39 800	12 900	220	1 140
							42 820	84 650	49 500	3 000				
15	1	8	4	8	1	46	41 740	78 250	73 700	5 000	52 600	14 900	450	1 870
							62 210	132 530	73 700	2 200				
15	1	8	4	8	1	46	41 740	78 250	73 700	5 000	56 000	56 000	450	2 030
							62 210	132 530	73 700	2 200				
15	1	8	4	8	1	46	41 740	78 250	73 700	5 000	59 300	59 300	450	2 220
							62 210	132 530	73 700	2 200				

CF..MA



ACCESSORIES

TYPE			
CF3M/CF4M/CF5M/CF6M/CF8M/CF10M/CF10-1M	—	—	Attached
CF10MK/CF10-1MK	φ 4 Attached	φ 4 Attached	Attached
CF12M/CF12-1M/CF16M/CF18M	φ 6 Attached	φ 6 Attached	Attached
CF20M/CF20-1M/CF24M/CF24-1M/CF30M/CF30-1M/CF30-2M	φ 8 Attached	φ 8 Attached	Attached

CAM FOLLOWERS STAINLESS STEEL

HEXAGON SOCKET ON BOTH SIDES
GREASE NIPPLE INSTALLED

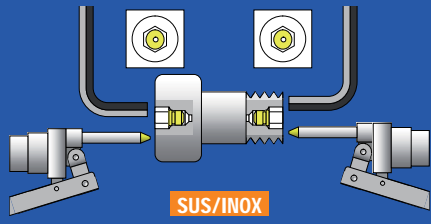

CF..MAB



CF..VMAB

CF..MAB TYPE

Stud diameter (mm)	Designation	Dimensions (mm)																			
		Cylindrical outer ring				Crowned outer ring R500(CF10 ~ CF18)				D		C		d		G		G1		B1	
h7 tolerance	Without seals	With seals	Without seals	With seals	D	C	d	G	G1	B1	B2										
10	CF10MABK	CF10MUABK	CF10MRABK	CF10MUURABK	22	12	10	M10×1	12	36	23										
	CF10VMABK	CF10VMUABK	CF10VMRABK	CF10VMUURABK																	
10	CF10-1MABK	CF10-1MUABK	CF10-1MRABK	CF10-1MUURABK	26	12	10	M10×1	12	36	23										
	CF10-1VMABK	CF10-1VMUABK	CF10-1VMRABK	CF10-1VMUURABK																	
12	CF12MAB	CF12MUAB	CF12MRAB	CF12MUURAB	30	14	12	M12×1.5	13	40	25										
	CF12VMAB	CF12VMUAB	CF12VMRAB	CF12VMUURAB																	
12	CF12-1MAB	CF12-1MUAB	CF12-1MRAB	CF12-1MUURAB	32	14	12	M12×1.5	13	40	25										
	CF12-1VMAB	CF12-1VMUAB	CF12-1VMRAB	CF12-1VMUURAB																	
16	CF16MAB	CF16MUAB	CF16MRAB	CF16MUURAB	35	18	16	M16×1.5	17	52	32.5										
	CF16VMAB	CF16VMUAB	CF16VMRAB	CF16VMUURAB																	
18	CF18MAB	CF18MUAB	CF18MRAB	CF18MUURAB	40	20	18	M18×1.5	19	58	36.5										
	CF18VMAB	CF18VMUAB	CF18VMRAB	CF18VMUURAB																	

CF..MAB TYPE has oil holes (grease nipple) which are prepared in the stud head and thread side, also an oil hole is prepared outer surface of stud.

* Without seals, suitable for grease lubrication. In case of oil lubrication, up to 130% of this value shall be permissible, and 70% of this value shall apply for types with seals.

OUTER RINGS TOLERANCE (μm)

TYPE	Cylindrical outer ring	Crowned outer ring
CF10,CF10-1,CF12	0/-9	0/-50
CF12-1,CF16,CF18,CF20-1	0/-11	0/-50
CF20,CF24,CF24-1,CF30	0/-13	0/-50
CF30-1,CF30-2	0/-15	0/-50

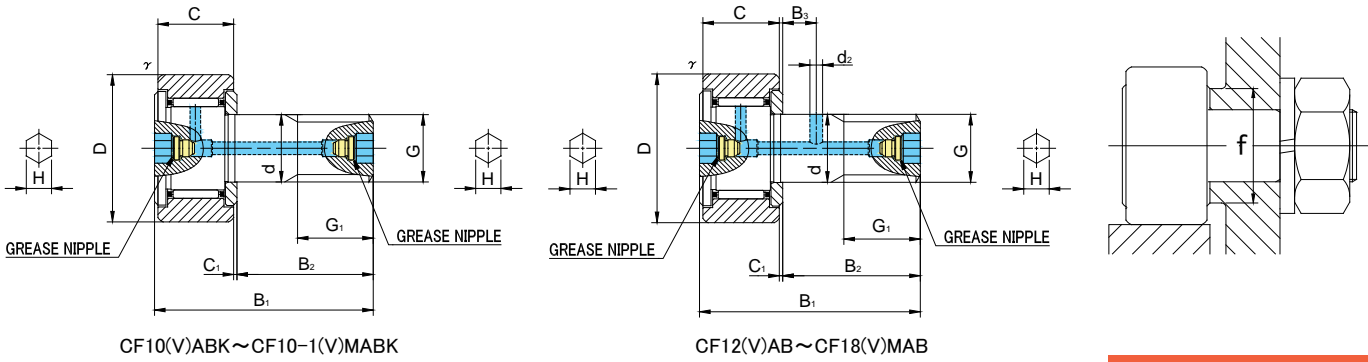

Prepacked Grease

						Basic dynamic load rating	Basic static load rating	Largest permissible load	Limiting speed *	Track load capacity		Max tightening torque	Mass
B3	C1	d2	H	r_s min	f min	Cr N	Cor N	N	rpm	Cylindrical outer ring N	Crowned outer ring N	N·m	g (approx)
—	0.6	—	5	0.3	15	4 950	6 310	6 860	17 000	4 700	1 670	15	45
						8 740	13 340	7 450	7 500				
—	0.6	—	5	0.3	15	4 950	6 310	6 860	17 000	5 490	2 060	15	60
						8 740	13 340	7 450	7 500				
6	0.6	3	6	0.6	20	7 300	9 010	9 800	14 000	7 060	2 450	22	95
						12 350	18 120	11 270	6 000				
6	0.6	3	6	0.6	20	7 300	9 010	9 800	14 000	7 450	2 740	22	105
						12 350	18 120	11 270	6 000				
8	0.8	3	6	0.6	24	11 080	16 860	18 330	10 000	11 200	3 140	58	170
						19 020	34 610	19 800	4 500				
8	0.8	3	6	1	26	13 520	23 180	25 200	8 500	14 400	3 720	87	250
						23 250	47 240	26 560	3 500				

CF..MAB



ACCESSORIES

TYPE		
All types	Installed	Attached

CAM FOLLOWERS STAINLESS STEEL

HEXAGON SOCKET ON BOTH SIDES
GREASE NIPPLE INSTALLED

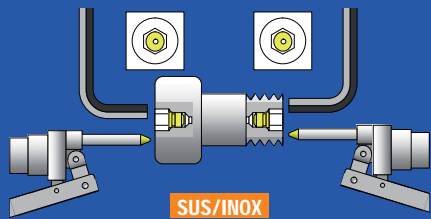

CF..MAB



CF..VMAB

CF..MAB TYPE

Stud diameter (mm)	h7 tolerance	Designation				Dimensions (mm)							
		Cylindrical outer ring		Crowned outer ring R1000(CF20 ≤)		D	C	d	G	G1	B1	B2	
		Without seals	With seals	Without seals	With seals								
20	0 -0.021	CF20MAB	CF20MUAB	CF20MRAB	CF20MUURAB	52	24	20	M20×1.5	21	66	40.5	
		CF20VMAB	CF20VMUAB	CF20VMRAB	CF20VMUURAB								
20	0 -0.021	CF20-1MAB	CF20-1MUAB	CF20-1MRAB	CF20-1MUURAB	47	24	20	M20×1.5	21	66	40.5	
		CF20-1VMAB	CF20-1VMUAB	CF20-1VMRAB	CF20-1VMUURAB								
24	0 -0.021	CF24MAB	CF24MUAB	CF24MRAB	CF24MUURAB	62	29	24	M24×1.5	25	80	49.5	
		CF24VMAB	CF24VMUAB	CF24VMRAB	CF24VMUURAB								
24	0 -0.021	CF24-1MAB	CF24-1MUAB	CF24-1MRAB	CF24-1MUURAB	72	29	24	M24×1.5	25	80	49.5	
		CF24-1VMAB	CF24-1VMUAB	CF24-1VMRAB	CF24-1VMUURAB								
30	0 -0.021	CF30MAB	CF30MUAB	CF30MRAB	CF30MUURAB	80	35	30	M30×1.5	32	100	63	
		CF30VMAB	CF30VMUAB	CF30VMRAB	CF30VMUURAB								
30	0 -0.021	CF30-1MAB	CF30-1MUAB	CF30-1MRAB	CF30-1MUURAB	85	35	30	M30×1.5	32	100	63	
		CF30-1VMAB	CF30-1VMUAB	CF30-1VMRAB	CF30-1VMUURAB								
30	0 -0.021	CF30-2MAB	CF30-2MUAB	CF30-2MRAB	CF30-2MUURAB	90	35	30	M30×1.5	32	100	63	
		CF30-2VMAB	CF30-2VMUAB	CF30-2VMRAB	CF30-2VMUURAB								

CF..MAB TYPE has oil holes (grease nipple) which are prepared in the stud head and thread side, also an oil hole is prepared outer surface of stud.

* Without seals, suitable for grease lubrication. In case of oil lubrication, up to 130% of this value shall be permissible, and 70% of this value shall apply for types with seals.

OUTER RINGS TOLERANCE (μm)

TYPE	Cylindrical outer ring	Crowned outer ring
CF10,CF10-1,CF12	0/-9	0/-50
CF12-1,CF16,CF18,CF20-1	0/-11	0/-50
CF20,CF24,CF24-1,CF30	0/-13	0/-50
CF30-1,CF30-2	0/-15	0/-50

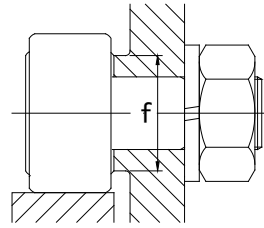
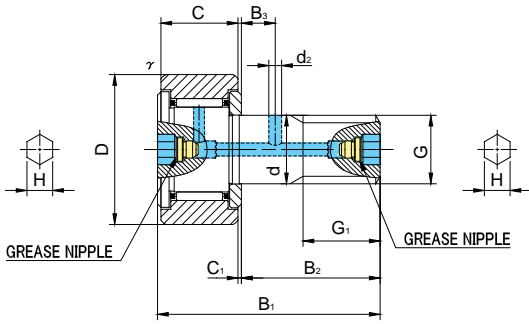

Prepacked Grease

						Basic dynamic load rating	Basic static load rating	Largest permissible load	Limiting speed *	Track load capacity		Max tightening torque	Mass
B3	C1	d2	H	r_s min	f min	Cr N	Cor N	N	rpm	Cylindrical outer ring N	Crowned outer ring N	N·m	g (approx)
9	0.8	4	8	1	36	19 020	31 830	32 140	7 000	23 200	8 230	120	460
						30 470	59 320	32 140	3 500				
9	0.8	4	8	1	36	19 020	31 830	32 140	7 000	21 000	7 150	120	385
						30 470	59 320	32 140	3 500				
11	0.8	4	8	1	40	28 040	48 410	49 500	6 500	34 200	10 500	220	815
						42 820	84 650	49 500	3 000				
11	0.8	4	8	1	40	28 040	48 410	49 500	6 500	39 800	12 900	220	1 140
						42 820	84 650	49 500	3 000				
15	1	4	8	1	46	41 740	78 250	73 700	5 000	52 600	14 900	450	1 870
						62 210	132 530	73 700	2 200				
15	1	4	8	1	46	41 740	78 250	73 700	5 000	56 000	16 100	450	2 030
						62 210	132 530	73 700	2 200				
15	1	4	8	1	46	41 740	78 250	73 700	5 000	59 300	17 300	450	2 220
						62 210	132 530	73 700	2 200				

CF..MAB



ACCESSORIES

TYPE		
All types	Installed	Attached

CAM FOLLOWERS STAINLESS STEEL SCREWDRIVER SLOT HEAD

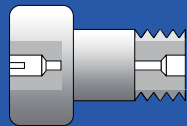

SUS/INOX



CF..M



CF..VM

CF..M TYPE

Stud diameter (mm)	h7 tolerance	Designation				Dimensions (mm)							
		Cylindrical outer ring		Crowned outer ring R250(CF5) R500(CF6 ~ CF10-1)		D	C	d	G	G1	B1	B2	
		Without seals	With seals	Without seals	With seals								
5	0 -0.012	CF 5M	CF 5MUU	CF 5MR	CF 5MUUR	13	9	5	M5×0.8	7.5	23	13	
		CF 5VM	CF 5VMUU	CF 5VMR	CF 5VMUUR								
6	0 -0.012	CF 6M	CF 6MUU	CF 6MR	CF 6MUUR	16	11	6	M6×1	8	28	16	
		CF 6VM	CF 6VMUU	CF 6VMR	CF 6VMUUR								
8	0 -0.015	CF 8M	CF 8MUU	CF 8MR	CF 8MUUR	19	11	8	M8×1.25	10	32	20	
		CF 8VM	CF 8VMUU	CF 8VMR	CF 8VMUUR								
10	0 -0.015	CF10M	CF10MUU	CF10MR	CF10MUUR	22	12	10	M10×1.25	12	36	23	
		CF10VM	CF10VMUU	CF10VMR	CF10VMUUR								
10	0 -0.015	CF10-1M	CF10-1MUU	CF10-1MR	CF10-1MUUR	26	12	10	M10×1.25	12	36	23	
		CF10-1VM	CF10-1VMUU	CF10-1VMR	CF10-1VMUUR								
10	0 -0.015	CF10MK	CF10MUUK	CF10MRK	CF10MUURK	22	12	10	M10×1	12	36	23	
		CF10VMK	CF10VMUUK	CF10VMRK	CF10VMUURK								
10	0 -0.015	CF10-1MK	CF10-1MUUK	CF10-1MRK	CF10-1MUURK	26	12	10	M10×1	12	36	23	
		CF10-1VMK	CF10-1VMUUK	CF10-1VMRK	CF10-1VMUURK								

* Without seals, suitable for grease lubrication. In case of oil lubrication, up to 130% of this value shall be permissible, and 70% of this value shall apply for types with seals.

OUTER RINGS TOLERANCE (μm)

TYPE	Cylindrical outer ring	Crowned outer ring
CF5M,CF6M	0/-8	0/-50
CF8M,CF10M,CF10-1M,CF12M	0/-9	0/-50
CF12-1M,CF16M,CF18M,CF20-1M	0/-11	0/-50
CF20M,CF24M,CF24-1M,CF30M	0/-13	0/-50
CF30-1M,CF30-2M	0/-15	0/-50

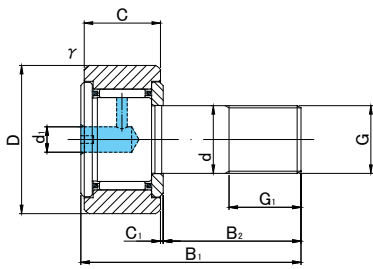

CF5(V)M~CF10-1(V)M

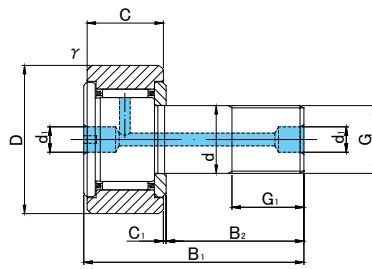

CF10(V)MK~CF10-1(V)MK

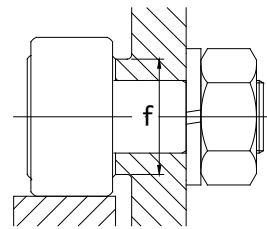

Prepacked Grease

						Basic dynamic load rating	Basic static load rating	Largest permissible load	Limiting speed *	Track load capacity		Max tightening torque	Mass
B3	C1	d1	d2	r_s min	f min	Cr N	Cor N	N	rpm	Cylindrical outer ring N	Crowned outer ring N	N·m	g (approx)
—	0.5	3.1	—	0.3	9.7	2 880	2 540	1 420	29 000	2 250	780	2	10.5
						4 690	5 060	1 420	11 600				
—	0.6	4	—	0.3	11	3 330	3 330	2 110	25 000	3 430	1 080	3	18.5
						6 400	7 840	2 110	12 000				
—	0.6	4	—	0.3	13	3 960	4 330	4 710	20 000	4 020	1 370	8	28.5
						7 470	10 270	4 710	9 000				
—	0.6	4	—	0.3	15	4 950	6 310	6 860	17 000	4 700	1 670	15	45
						8 740	13 340	7 450	7 500				
—	0.6	4	—	0.3	15	4 950	6 310	6 860	17 000	5 490	2 060	15	60
						8 740	13 340	7 450	7 500				
—	0.6	4	—	0.3	15	4 950	6 310	6 860	17 000	4 700	1 670	15	45
						8 740	13 340	7 450	7 500				
—	0.6	4	—	0.3	15	4 950	6 310	6 860	17 000	5 490	2 060	15	60
						8 740	13 340	7 450	7 500				

CF..M



ACCESSORIES

TYPE			
	STOP PLUG	RESIN PLUG	NUT
CF5M	—	—	Attached
CF6M/CF8M/CF10M/CF10-1M	—	φ 4 Attached	Attached
CF10MK/CF10-1MK	φ 4 Attached	φ 4 Attached	Attached
CF12M/CF12-1M/CF16M/CF18M	φ 6 Attached	φ 6 Attached	Attached
CF20M/CF20-1M/CF24M/CF24-1M/CF30M/CF30-1M/CF30-2M	φ 8 Attached	φ 8 Attached	Attached

CAM FOLLOWERS STAINLESS STEEL SCREWDRIVER SLOT HEAD

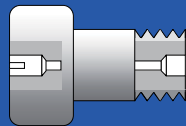

SUS/INOX



CF..M



CF..VM

CF..M TYPE

Stud diameter (mm)	h7 tolerance	Designation				Dimensions (mm)							
		Cylindrical outer ring		Crowned outer ring R500(CF12 ~ CF18) R1000(CF20 ≤)		D	C	d	G	G1	B1	B2	
		Without seals	With seals	Without seals	With seals								
12	0 -0.018	CF12M	CF12MUU	CF12MR	CF12MUUR	30	14	12	M12×1.5	13	40	25	
		CF12VM	CF12VMUU	CF12VMR	CF12VMUUR								
12	0 -0.018	CF12-1M	CF12-1MUU	CF12-1MR	CF12-1MUUR	32	14	12	M12×1.5	13	40	25	
		CF12-1VM	CF12-1VMUU	CF12-1VMR	CF12-1VMUUR								
16	0 -0.018	CF16M	CF16MUU	CF16MR	CF16MUUR	35	18	16	M16×1.5	17	52	32.5	
		CF16VM	CF16VMUU	CF16VMR	CF16VMUUR								
18	0 -0.018	CF18M	CF18MUU	CF18MR	CF18MUUR	40	20	18	M18×1.5	19	58	36.5	
		CF18VM	CF18VMUU	CF18VMR	CF18VMUUR								
20	0 -0.021	CF20M	CF20MUU	CF20MR	CF20MUUR	52	24	20	M20×1.5	21	66	40.5	
		CF20VM	CF20VMUU	CF20VMR	CF20VMUUR								
20	0 -0.021	CF20-1M	CF20-1MUU	CF20-1MR	CF20-1MUUR	47	24	20	M20×1.5	21	66	40.5	
		CF20-1VM	CF20-1VMUU	CF20-1VMR	CF20-1VMUUR								
24	0 -0.021	CF24M	CF24MUU	CF24MR	CF24MUUR	62	29	24	M24×1.5	25	80	49.5	
		CF24VM	CF24VMUU	CF24VMR	CF24VMUUR								
24	0 -0.021	CF24-1M	CF24-1MUU	CF24-1MR	CF24-1MUUR	72	29	24	M24×1.5	25	80	49.5	
		CF24-1VM	CF24-1VMUU	CF24-1VMR	CF24-1VMUUR								
30	0 -0.021	CF30M	CF30MUU	CF30MR	CF30MUUR	80	35	30	M30×1.5	32	100	63	
		CF30VM	CF30VMUU	CF30VMR	CF30VMUUR								
30	0 -0.021	CF30-1M	CF30-1MUU	CF30-1MR	CF30-1MUUR	85	35	30	M30×1.5	32	100	63	
		CF30-1VM	CF30-1VMUU	CF30-1VMR	CF30-1VMUUR								
30	0 -0.021	CF30-2M	CF30-2MUU	CF30-2MR	CF30-2MUUR	90	35	30	M30×1.5	32	100	63	
		CF30-2VM	CF30-2VMUU	CF30-2VMR	CF30-2VMUUR								

* Without seals, suitable for grease lubrication. In case of oil lubrication, up to 130% of this value shall be permissible, and 70% of this value shall apply for types with seals.

OUTER RINGS TOLERANCE (μm)

TYPE	Cylindrical outer ring	Crowned outer ring
CF5M,CF6M	0/-8	0/-50
CF8M,CF10M,CF10-1M,CF12M	0/-9	0/-50
CF12-1M,CF16M,CF18M,CF20-1M	0/-11	0/-50
CF20M,CF24M,CF24-1M,CF30M	0/-13	0/-50
CF30-1M,CF30-2M	0/-15	0/-50



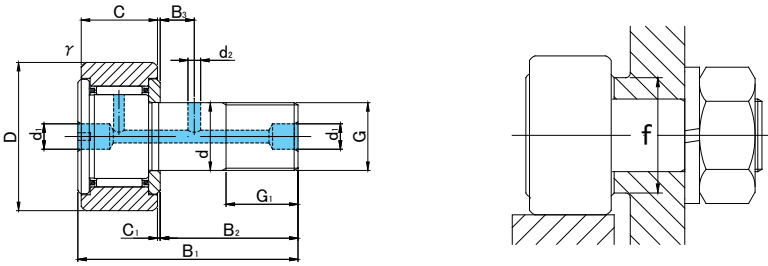

Prepacked Grease

						Basic dynamic load rating	Basic static load rating	Largest permissible load	Limiting speed *	Track load capacity		Max tightening torque	Mass
B3	C1	d1	d2	r_s min	f min	Cr N	Cor N	N	rpm	Cylindrical outer ring N	Crowned outer ring N	N·m	g (approx)
6	0.6	6	3	0.6	20	7 300	9 010	9 800	14 000	7 060	2 450	22	95
						12 350	18 120	11 270	6 000				
6	0.6	6	3	0.6	20	7 300	9 010	9 800	14 000	7 450	2 740	22	105
						12 350	18 120	11 270	6 000				
8	0.8	6	3	0.6	24	11 080	16 860	18 330	10 000	11 200	3 140	58	170
						19 020	34 610	19 800	4 500				
8	0.8	6	3	1	26	13 520	23 180	25 200	8 500	14 400	3 720	87	250
						23 250	47 240	26 560	3 500				
9	0.8	8	4	1	36	19 020	31 830	32 140	7 000	23 200	8 230	120	460
						30 470	59 320	32 140	3 500				
9	0.8	8	4	1	36	19 020	31 830	32 140	7 000	21 000	7 150	120	385
						30 470	59 320	32 140	3 500				
11	0.8	8	4	1	40	28 040	48 410	49 500	6 500	34 200	10 500	220	815
						42 820	84 650	49 500	3 000				
11	0.8	8	4	1	40	28 040	48 410	49 500	6 500	39 800	12 900	220	1 140
						42 820	84 650	49 500	3 000				
15	1	8	4	1	46	41 740	78 250	73 700	5 000	52 600	14 900	450	1 870
						62 210	132 530	73 700	2 200				
15	1	8	4	1	46	41 740	78 250	73 700	5 000	56 000	16 100	450	2 030
						62 210	132 530	73 700	2 200				
15	1	8	4	1	46	41 740	78 250	73 700	5 000	59 300	17 300	450	2 220
						62 210	132 530	73 700	2 200				

CF.M

ACCESSORIES

TYPE			
	STOP PLUG	RESIN PLUG	NUT
CF5M	—	—	Attached
CF6M/CF8M/CF10M/CF10-1M	—	φ 4 Attached	Attached
CF10MK/CF10-1MK	φ 4 Attached	φ 4 Attached	Attached
CF12M/CF12-1M/CF16M/CF18M	φ 6 Attached	φ 6 Attached	Attached
CF20M/CF20-1M/CF24M/CF24-1M/CF30M/CF30-1M/CF30-2M	φ 8 Attached	φ 8 Attached	Attached

CAM FOLLOWERS STAINLESS STEEL

HEXAGON SOCKET ON THREAD SIDE
SCREWDRIVER SLOT HEAD

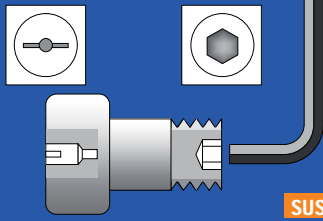

SUS/INOX



CF..MB



CF..VMB

CF..MB TYPE

Stud diameter (mm)		Designation				Dimensions (mm)					
		Cylindrical outer ring		Crowned outer ring R500 (CF12 ~ CF18) R1000 (CF20 ≤)		D	C	G	G1	B1	B2
d	h7 tolerance	Without seals	With seals	Without seals	With seals						
12	0 -0.018	CF12MB	CF12MUUB	CF12MRB	CF12MUURB	30	14	M12×1.5	13	40	25
		CF12VMB	CF12VMUUB	CF12VMRB	CF12VMUURB						
12	0 -0.018	CF12-1MB	CF12-1MUUB	CF12-1MRB	CF12-1MUURB	32	14	M12×1.5	13	40	25
		CF12-1VMB	CF12-1VMUUB	CF12-1VMRB	CF12-1VMUURB						
16	0 -0.018	CF16MB	CF16MUUB	CF16MRB	CF16MUURB	35	18	M16×1.5	17	52	32.5
		CF16VMB	CF16VMUUB	CF16VMRB	CF16VMUURB						
18	0 -0.018	CF18MB	CF18MUUB	CF18MRB	CF18MUURB	40	20	M18×1.5	19	58	36.5
		CF18VMB	CF18VMUUB	CF18VMRB	CF18VMUURB						
20	0 -0.021	CF20MB	CF20MUUB	CF20MRB	CF20MUURB	52	24	M20×1.5	21	66	40.5
		CF20VMB	CF20VMUUB	CF20VMRB	CF20VMUURB						
20	0 -0.021	CF20-1MB	CF20-1MUUB	CF20-1MRB	CF20-1MUURB	47	24	M20×1.5	21	66	40.5
		CF20-1VMB	CF20-1VMUUB	CF20-1VMRB	CF20-1VMUURB						
24	0 -0.021	CF24MB	CF24MUUB	CF24MRB	CF24MUURB	62	29	M24×1.5	25	80	49.5
		CF24VMB	CF24VMUUB	CF24VMRB	CF24VMUURB						
24	0 -0.021	CF24-1MB	CF24-1MUUB	CF24-1MRB	CF24-1MUURB	72	29	M24×1.5	25	80	49.5
		CF24-1VMB	CF24-1VMUUB	CF24-1VMRB	CF24-1VMUURB						
30	0 -0.021	CF30MB	CF30MUUB	CF30MRB	CF30MUURB	80	35	M30×1.5	32	100	63
		CF30VMB	CF30VMUUB	CF30VMRB	CF30VMUURB						
30	0 -0.021	CF30-1MB	CF30-1MUUB	CF30-1MRB	CF30-1MUURB	85	35	M30×1.5	32	100	63
		CF30-1VMB	CF30-1VMUUB	CF30-1VMRB	CF30-1VMUURB						
30	0 -0.021	CF30-2MB	CF30-2MUUB	CF30-2MRB	CF30-2MUURB	90	35	M30×1.5	32	100	63
		CF30-2VMB	CF30-2VMUUB	CF30-2VMRB	CF30-2VMUURB						

CF..MB



* Without seals, suitable for grease lubrication. In case of oil lubrication, up to 130% of this value shall be permissible, and 70% of this value shall apply for types with seals.

OUTER RINGS TOLERANCE (μm)

TYPE	Cylindrical outer ring	Crowned outer ring
CF12M	0/-9	0/-50
CF12-1M, CF16M, CF18M, CF20-1M	0/-11	0/-50
CF20M, CF24M, CF24-1M, CF30M	0/-13	0/-50
CF30-1M, CF30-2M	0/-15	0/-50

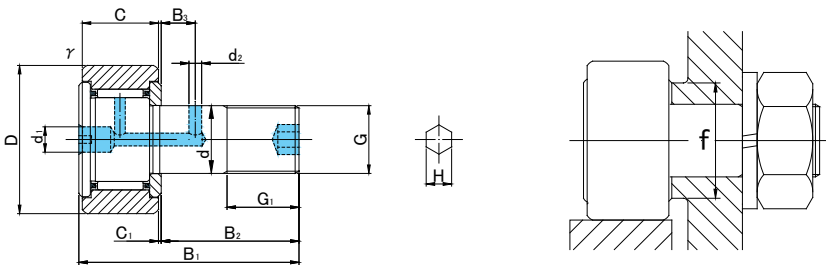

Prepacked Grease

							Basic dynamic load rating	Basic static load rating	Largest permissible load	Limiting speed *	Track load capacity		Max tightening torque	Mass
B3	C1	d1	d2	H	rs min	f min	Cr N	Cor N	N	rpm	Cylindrical outer ring N	Crowned outer ring N	N·m	g (approx)
6	0.6	6	3	6	0.6	20	7 300	9 010	9 800	14 000	7 060	2 450	22	95
							12 350	18 120	11 270	6 000				
6	0.6	6	3	6	0.6	20	7 300	9 010	9 800	14 000	7 450	2 740	22	105
							12 350	18 120	11 270	6 000				
8	0.8	6	3	6	0.6	24	11 080	16 860	18 330	10 000	11 200	3 140	58	170
							19 020	34 610	19 800	4 500				
8	0.8	6	3	6	1	26	13 520	23 180	25 200	8 500	14 400	3 720	87	250
							23 250	47 240	26 560	3 500				
9	0.8	8	4	8	1	36	19 020	31 830	32 140	7 000	23 200	8 230	120	460
							30 470	59 320	32 140	3 500				
9	0.8	8	4	8	1	36	19 020	31 830	32 140	7 000	21 000	7 150	120	385
							30 470	59 320	32 140	3 500				
11	0.8	8	4	8	1	40	28 040	48 410	49 500	6 500	34 200	10 500	220	815
							42 820	84 650	49 500	3 000				
11	0.8	8	4	8	1	40	28 040	48 410	49 500	6 500	39 800	12 900	220	1 140
							42 820	84 650	49 500	3 000				
15	1	8	4	8	1	46	41 740	78 250	73 700	5 000	52 600	14 900	450	1 870
							62 210	132 530	73 700	2 200				
15	1	8	4	8	1	46	41 740	78 250	73 700	5 000	56 000	16 100	450	2 030
							62 210	132 530	73 700	2 200				
15	1	8	4	8	1	46	41 740	78 250	73 700	5 000	59 300	17 300	450	2 220
							62 210	132 530	73 700	2 200				

CF..MB



ACCESSORIES

TYPE			
CF3M/CF4M/CF5M	—	—	Attached
CF6M/CF8M/CF10M/CF10-1M	—	—	Attached
CF12M/CF12-1M/CF16M/CF18M	φ 6 Attached	φ 6 Attached	Attached
CF20M/CF20-1M/CF24M/CF24-1M/CF30M/CF30-1M/CF30-2M	φ 8 Attached	φ 8 Attached	Attached

CAM FOLLOWERS STAINLESS STEEL

SOLID ECCENTRIC TYPE
HEXAGON SOCKET ON STUD HEAD

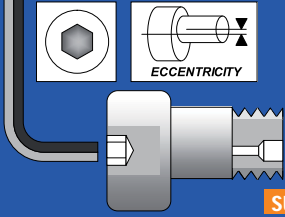

CFH..MA



CFH..VMA

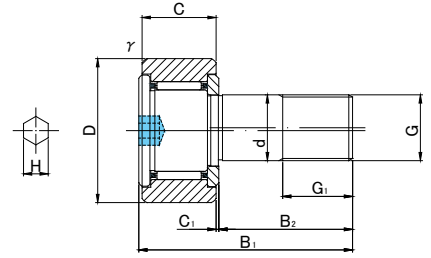

CFH5(V)MA~CFH10-1(V)MA

CFH..MA TYPE

Stud diameter (mm)	h7 tolerance	Designation				Dimensions (mm)						
		Cylindrical outer ring		Crowned outer ring R500(CF5 ~ CF12)		D	C	d	G	G1	B1	B2
5	0 -0.012	CFH 5MA	CFH 5MUUA	CFH 5MRA	CFH 5MUURA	13	9	5	M5×0.8	7.5	23	13
		CFH 5VMA	CFH 5VMUUA	CFH 5VMRA	CFH 5VMUURA							
6	0 -0.012	CFH 6MA	CFH 6MUUA	CFH 6MRA	CFH 6MUURA	16	11	6	M6×1	8	28	16
		CFH 6VMA	CFH 6VMUUA	CFH 6VMRA	CFH 6VMUURA							
8	0 -0.015	CFH 8MA	CFH 8MUUA	CFH 8MRA	CFH 8MUURA	19	11	8	M8×1.25	10	32	20
		CFH 8VMA	CFH 8VMUUA	CFH 8VMRA	CFH 8VMUURA							
10	0 -0.015	CFH10MA	CFH10MUUA	CFH10MRA	CFH10MUURA	22	12	10	M10×1.25	12	36	23
		CFH10VMA	CFH10VMUUA	CFH10VMRA	CFH10VMUURA							
10	0 -0.015	CFH10-1MA	CFH10-1MUUA	CFH10-1MRA	CFH10-1MUURA	26	12	10	M10×1.25	12	36	23
		CFH10-1VMA	CFH10-1VMUUA	CFH10-1VMRA	CFH10-1VMUURA							
12	0 -0.018	CFH12MA	CFH12MUUA	CFH12MRA	CFH12MUURA	30	14	12	M12×1.5	13	40	25
		CFH12VMA	CFH12VMUUA	CFH12VMRA	CFH12VMUURA							
12	0 -0.018	CFH12-1MA	CFH12-1MUUA	CFH12-1MRA	CFH12-1MUURA	32	14	12	M12×1.5	13	40	25
		CFH12-1VMA	CFH12-1VMUUA	CFH12-1VMRA	CFH12-1VMUURA							

* Without seals, suitable for grease lubrication. In case of oil lubrication, up to 130% of this value shall be permissible, and 70% of this value shall apply for types with seals.

OUTER RINGS TOLERANCE (μm)

TYPE	Cylindrical outer ring	Crowned outer ring
CF5M,CF6M	0/-8	0/-50
CF8M,CF10M,CF10-1M,CF12M	0/-9	0/-50
CF12-1M,CF16M,CF18M,CF20-1M	0/-11	0/-50
CF20M,CF24M,CF24-1M,CF30M	0/-13	0/-50
CF30-1M,CF30-2M	0/-15	0/-50



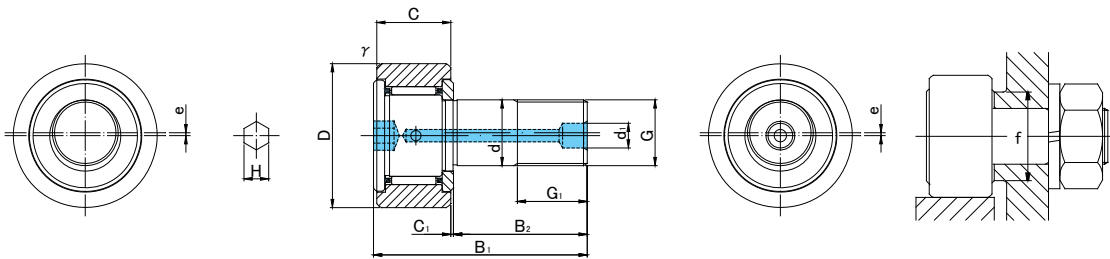

CFH12(V)MA~CFH12-1(V)MA

Prepacked Grease

						Basic dynamic load rating	Basic static load rating	Largest permissible load	Limiting speed *	Track load capacity		Max tightening torque	Mass
C1	d1	H	r/s min	e	f min	Cr N	Cor N	N	rpm	Cylindrical outer ring N	Crowned outer ring N	N·m	g (approx)
0.5	—	2.5	0.3	0.2	9.7	2 880	2 540	1 420	29 000	2 250	780	2	10.5
						4 690	5 060	1 420	11 600				
0.6	—	3	0.3	0.25	11	3 330	3 330	2 110	25 000	3 430	1 080	3	18.5
						6 400	7 840	2 110	12 000				
0.6	—	4	0.3	0.25	13	3 960	4 330	4 710	20 000	4 020	1 370	8	28.5
						7 470	10 270	4 710	9 000				
0.6	—	5	0.3	0.3	15	4 950	6 310	6 860	17 000	4 700	1 670	15	45
						8 740	13 340	7 450	7 500				
0.6	—	5	0.3	0.3	15	4 950	6 310	6 860	17 000	5 490	2 060	15	60
						8 740	13 340	7 450	7 500				
0.6	6	6	0.6	0.4	20	7 300	9 010	9 800	14 000	7 060	2 450	22	95
						12 350	18 120	11 270	6 000				
0.6	6	6	0.6	0.4	20	7 300	9 010	9 800	14 000	7 450	2 740	22	105
						12 350	18 120	11 270	6 000				

CFH..MA



ACCESSORIES

TYPE			
CF3M/CF4M/CF5M	—	—	Attached
CF6M/CF8M/CF10M/CF10-1M	—	—	Attached
CF12M/CF12-1M/CF16M/CF18M	φ 6 Attached	φ 6 Attached	Attached
CF20M/CF20-1M/CF24M/CF24-1M/CF30M/CF30-1M/CF30-2M	φ 8 Attached	φ 8 Attached	Attached

CAM FOLLOWERS STAINLESS STEEL

SOLID ECCENTRIC TYPE
HEXAGON SOCKET ON STUD HEAD

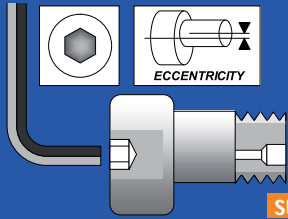

CFH..MA



CFH..VMA

CFH..MA TYPE

Stud diameter (mm)	h7 tolerance	Designation				Dimensions (mm)						
		Cylindrical outer ring		Crowned outer ring R500(CF16 ~ CF18) R1000(CF20 ≤)		D	C	d	G	G1	B1	B2
		Without seals	With seals	Without seals	With seals							
16	0 -0.018	CFH16MA	CFH16MUUA	CFH16MRA	CFH16MUURA	35	18	16	M16×1.5	17	52	32.5
		CFH16VMA	CFH16VMUUA	CFH16VMRA	CFH16VMUURA							
18	0 -0.018	CFH18MA	CFH18MUUA	CFH18MRA	CFH18MUURA	40	20	18	M18×1.5	19	58	36.5
		CFH18VMA	CFH18VMUUA	CFH18VMRA	CFH18VMUURA							
20	0 -0.021	CFH20MA	CFH20MUUA	CFH20MRA	CFH20MUURA	52	24	20	M20×1.5	21	66	40.5
		CFH20VMA	CFH20VMUUA	CFH20VMRA	CFH20VMUURA							
20	0 -0.021	CFH20-1MA	CFH20-1MUUA	CFH20-1MRA	CFH20-1MUURA	47	24	20	M20×1.5	21	66	40.5
		CFH20-1VMA	CFH20-1VMUUA	CFH20-1VMRA	CFH20-1VMUURA							
24	0 -0.021	CFH24MA	CFH24MUUA	CFH24MRA	CFH24MUURA	62	29	24	M24×1.5	25	80	49.5
		CFH24VMA	CFH24VMUUA	CFH24VMRA	CFH24VMUURA							
24	0 -0.021	CFH24-1MA	CFH24-1MUUA	CFH24-1MRA	CFH24-1MUURA	72	29	24	M24×1.5	25	80	49.5
		CFH24-1VMA	CFH24-1VMUUA	CFH24-1VMRA	CFH24-1VMUURA							
30	0 -0.021	CFH30MA	CFH30MUUA	CFH30MRA	CFH30MUURA	80	35	30	M30×1.5	32	100	63
		CFH30VMA	CFH30VMUUA	CFH30VMRA	CFH30VMUURA							
30	0 -0.021	CFH30-1MA	CFH30-1MUUA	CFH30-1MRA	CFH30-1MUURA	85	35	30	M30×1.5	32	100	63
		CFH30-1VMA	CFH30-1VMUUA	CFH30-1VMRA	CFH30-1VMUURA							
30	0 -0.021	CFH30-2MA	CFH30-2MUUA	CFH30-2MRA	CFH30-2MUURA	90	35	30	M30×1.5	32	100	63
		CFH30-2VMA	CFH30-2VMUUA	CFH30-2VMRA	CFH30-2VMUURA							

* Without seals, suitable for grease lubrication. In case of oil lubrication, up to 130% of this value shall be permissible, and 70% of this value shall apply for types with seals.

OUTER RINGS TOLERANCE (μm)

TYPE	Cylindrical outer ring	Crowned outer ring
CF5M,CF6M	0/-8	0/-50
CF8M,CF10M,CF10-1M,CF12M	0/-9	0/-50
CF12-1M,CF16M,CF18M,CF20-1M	0/-11	0/-50
CF20M,CF24M,CF24-1M,CF30M	0/-13	0/-50
CF30-1M,CF30-2M	0/-15	0/-50



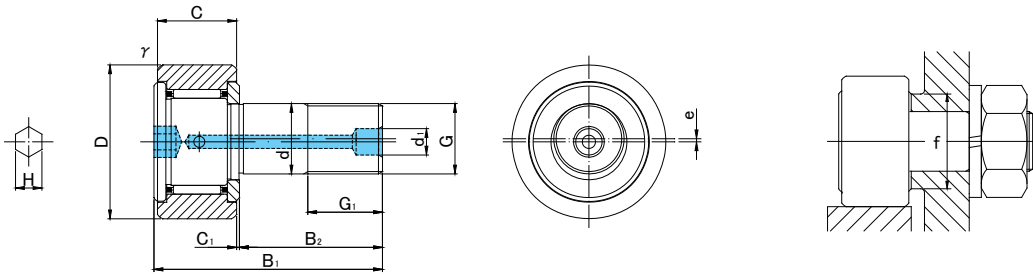

Prepacked Grease

						Basic dynamic load rating	Basic static load rating	Largest permissible load	Limiting speed *	Track load capacity		Max tightening torque	Mass
C1	d1	H	r/s min	e	f min	Cr N	Cor N	N	rpm	Cylindrical outer ring N	Crowned outer ring N	N·m	g (approx)
0.8	6	6	0.6	0.5	24	11 080	16 860	18 330	10 000	11 200	3 140	58	170
						19 020	34 610	19 800	4 500				
0.8	6	6	1	0.6	26	13 520	23 180	25 200	8 500	14 400	3 720	87	250
						23 250	47 240	26 560	3 500				
0.8	8	8	1	0.7	36	19 020	31 830	32 140	7 000	23 200	8 230	120	460
						30 470	59 320	32 140	3 500				
0.8	8	8	1	0.7	36	19 020	31 830	32 140	7 000	21 000	7 150	120	385
						30 470	59 320	32 140	3 500				
0.8	8	8	1	0.8	40	28 040	48 410	49 500	6 500	34 200	10 500	220	815
						42 820	84 650	49 500	3 000				
0.8	8	8	1	0.8	40	28 040	48 410	49 500	6 500	39 800	12 900	220	1 140
						42 820	84 650	49 500	3 000				
1	8	8	1	1	46	41 740	78 250	73 700	5 000	52 600	14 900	450	1 870
						62 210	132 530	73 700	2 200				
1	8	8	1	1	46	41 740	78 250	73 700	5 000	56 000	16 100	450	2 030
						62 210	132 530	73 700	2 200				
1	8	8	1	1	46	41 740	78 250	73 700	5 000	59 300	17 300	450	2 220
						62 210	132 530	73 700	2 200				

CFH..MA



ACCESSORIES

TYPE			
CF3M/CF4M/CF5M	—	—	Attached
CF6M/CF8M/CF10M/CF10-1M	—	—	Attached
CF12M/CF12-1M/CF16M/CF18M	φ 6 Attached	φ 6 Attached	Attached
CF20M/CF20-1M/CF24M/CF24-1M/CF30M/CF30-1M/CF30-2M	φ 8 Attached	φ 8 Attached	Attached

CAM FOLLOWERS STAINLESS STEEL

SOLID ECCENTRIC TYPE
HEXAGON SOCKET ON BOTH SIDES
GREASE NIPPLE INSTALLED

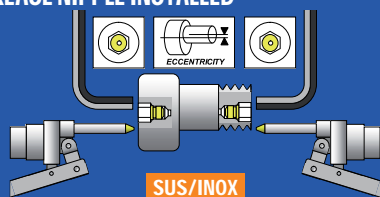

CFH..MAB



CFH..VMAB

CFH..MAB TYPE

Stud diameter (mm)	h7 tolerance	Designation				Dimensions (mm)							
		Cylindrical outer ring		Crowned outer ring R500(CF12 ~ CF18) R1000(CF20 ≤)		D	C	d	G	G1	B1	B2	
		Without seals	With seals	Without seals	With seals								
12	0 -0.018	CFH12MAB	CFH12MUAB	CFH12MRAB	CFH12MUURAB	30	14	12	M12×1.5	13	40	25	
		CFH12VMAB	CFH12VMUAB	CFH12VMRAB	CFH12VMURAB								
12	0 -0.018	CFH12-1MAB	CFH12-1MUAB	CFH12-1MRAB	CFH12-1MUURAB	32	14	12	M12×1.5	13	40	25	
		CFH12-1VMAB	CFH12-1VMUAB	CFH12-1VMRAB	CFH12-1VMURAB								
16	0 -0.018	CFH16MAB	CFH16MUAB	CFH16MRAB	CFH16MUURAB	35	18	16	M16×1.5	17	52	32.5	
		CFH16VMAB	CFH16VMUAB	CFH16VMRAB	CFH16VMURAB								
18	0 -0.018	CFH18MAB	CFH18MUAB	CFH18MRAB	CFH18MUURAB	40	20	18	M18×1.5	19	58	36.5	
		CFH18VMAB	CFH18VMUAB	CFH18VMRAB	CFH18VMURAB								
20	0 -0.021	CFH20MAB	CFH20MUAB	CFH20MRAB	CFH20MUURAB	52	24	20	M20×1.5	21	66	40.5	
		CFH20VMAB	CFH20VMUAB	CFH20VMRAB	CFH20VMURAB								
20	0 -0.021	CFH20-1MAB	CFH20-1MUAB	CFH20-1MRAB	CFH20-1MUURAB	47	24	20	M20×1.5	21	66	40.5	
		CFH20-1VMAB	CFH20-1VMUAB	CFH20-1VMRAB	CFH20-1VMURAB								

CFH..MAB TYPE has oil holes (grease nipple) which are prepared in the stud head and thread side, also an oil hole is prepared outer surface of stud.

* Without seals, suitable for grease lubrication. In case of oil lubrication, up to 130% of this value shall be permissible, and 70% of this value shall apply for types with seals.

OUTER RINGS TOLERANCE (μm)

TYPE	Cylindrical outer ring	Crowned outer ring
CF12	0/-9	0/-50
CF12-1,CF16,CF18,CF20-1	0/-11	0/-50
CF20,CF24,CF24-1,CF30	0/-13	0/-50
CF30-1,CF30-2	0/-15	0/-50



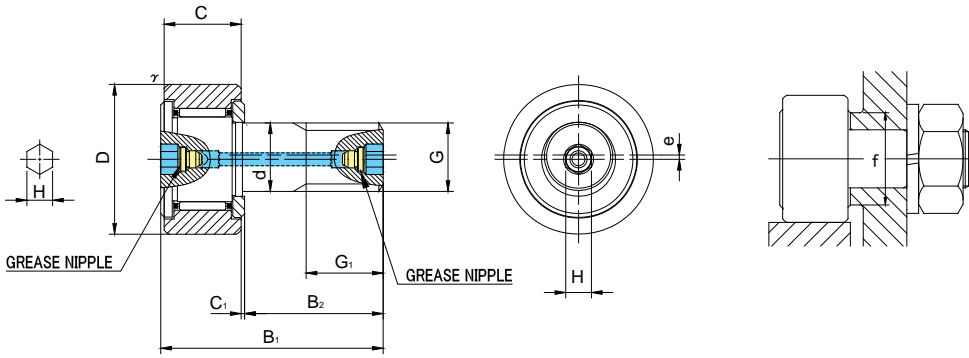

Prepacked Grease

					Basic dynamic load rating	Basic static load rating	Largest permissible load	Limiting speed *	Track load capacity		Max tightening torque	Mass
C1	H	f/s min	e	f min	Cr N	Cor N	N	rpm	Cylindrical outer ring N	Crowned outer ring N	N·m	g (approx)
0.6	6	0.6	0.4	20	7 300	9 010	9 800	14 000	7 060	2 450	22	95
					12 350	18 120	11 270	6 000				
0.6	6	0.6	0.4	20	7 300	9 010	9 800	14 000	7 450	2 740	22	105
					12 350	18 120	11 270	6 000				
0.8	6	0.6	0.5	24	11 080	16 860	18 330	10 000	11 200	3 140	58	170
					19 020	34 610	19 800	4 500				
0.8	6	1	0.6	26	13 520	23 180	25 200	8 500	14 400	3 720	87	250
					23 250	47 240	26 560	3 500				
0.8	8	1	0.7	36	19 020	31 830	32 140	7 000	23 200	8 230	120	460
					30 470	59 320	32 140	3 500				
0.8	8	1	0.7	36	19 020	31 830	32 140	7 000	21 000	7 150	120	385
					30 470	59 320	32 140	3 500				

CFH...MAB



ACCESSORIES

TYPE		
All types	Installed	Attached

CAM FOLLOWERS STAINLESS STEEL

SOLID ECCENTRIC TYPE
HEXAGON SOCKET ON BOTH SIDES
GREASE NIPPLE INSTALLED

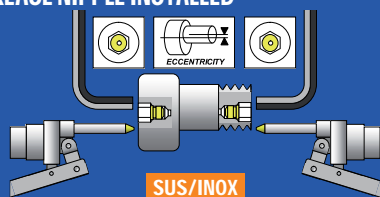

CFH..MAB



CFH..VMAB

CFH..MAB TYPE

Stud diameter (mm)	h7 tolerance	Designation				Dimensions (mm)							
		Cylindrical outer ring		Crowned outer ring R1000(CF24 ≤)		D	C	d	G	G1	B1	B2	
		Without seals	With seals	Without seals	With seals								
24	0 -0.021	CFH24MAB	CFH24MUAB	CFH24MRAB	CFH24MUURAB	62	29	24	M24×1.5	25	80	49.5	
		CFH24VMAB	CFH24VMUAB	CFH24VMRAB	CFH24VMUURAB								
24	0 -0.021	CFH24-1MAB	CFH24-1MUAB	CFH24-1MRAB	CFH24-1MUURAB	72	29	24	M24×1.5	25	80	49.5	
		CFH24-1VMAB	CFH24-1VMUAB	CFH24-1VMRAB	CFH24-1VMUURAB								
30	0 -0.021	CFH30MAB	CFH30MUAB	CFH30MRAB	CFH30MUURAB	80	35	30	M30×1.5	32	100	63	
		CFH30VMAB	CFH30VMUAB	CFH30VMRAB	CFH30VMUURAB								
30	0 -0.021	CFH30-1MAB	CFH30-1MUAB	CFH30-1MRAB	CFH30-1MUURAB	85	35	30	M30×1.5	32	100	63	
		CFH30-1VMAB	CFH30-1VMUAB	CFH30-1VMRAB	CFH30-1VMUURAB								
30	0 -0.021	CFH30-2MAB	CFH30-2MUAB	CFH30-2MRAB	CFH30-2MUURAB	90	35	30	M30×1.5	32	100	63	
		CFH30-2VMAB	CFH30-2VMUAB	CFH30-2VMRAB	CFH30-2VMUURAB								

CFH..MAB TYPE has oil holes (grease nipple) which are prepared in the stud head and thread side, also an oil hole is prepared outer surface of stud.

* Without seals, suitable for grease lubrication. In case of oil lubrication, up to 130% of this value shall be permissible, and 70% of this value shall apply for types with seals.

OUTER RINGS TOLERANCE (μm)

TYPE	Cylindrical outer ring	Crowned outer ring
CF12	0/-9	0/-50
CF12-1,CF16,CF18,CF20-1	0/-11	0/-50
CF20,CF24,CF24-1,CF30	0/-13	0/-50
CF30-1,CF30-2	0/-15	0/-50



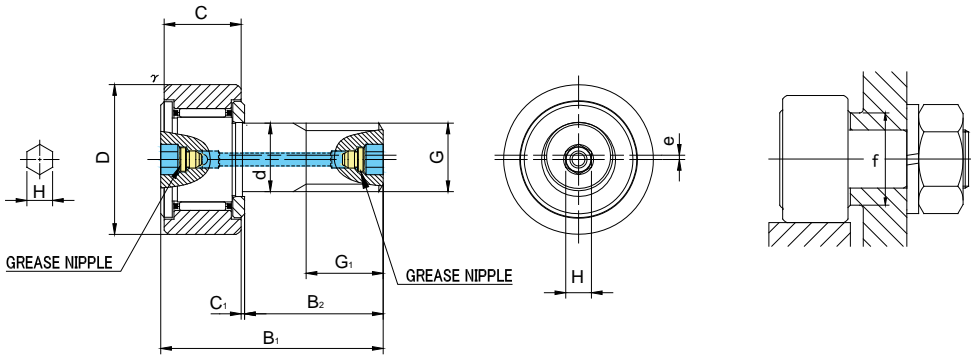

Prepacked Grease

					Basic dynamic load rating	Basic static load rating	Largest permissible load	Limiting speed *	Track load capacity		Max tightening torque	Mass
C1	H	f_s min	e	f min	Cr N	Cor N	N	rpm	Cylindrical outer ring N	Crowned outer ring N	N·m	g (approx)
0.8	8	1	0.8	40	28 040	48 410	49 500	6 500	34 200	10 500	220	815
					42 820	84 650	49 500	3 000				
0.8	8	1	0.8	40	28 040	48 410	49 500	6 500	39 800	12 900	220	1 140
					42 820	84 650	49 500	3 000				
1	8	1	1	46	41 740	78 250	73 700	5 000	52 600	14 900	450	1 870
					62 210	132 530	73 700	2 200				
1	8	1	1	46	41 740	78 250	73 700	5 000	56 000	16 100	450	2 030
					62 210	132 530	73 700	2 200				
1	8	1	1	46	41 740	78 250	73 700	5 000	59 300	17 300	450	2 220
					62 210	132 530	73 700	2 200				

CFH...MAB



ACCESSORIES

TYPE		
All types	Installed	Attached

CAM FOLLOWERS STAINLESS STEEL

SOLID ECCENTRIC TYPE
SCREWDRIVER SLOT HEAD

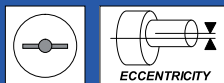

ECCENTRICITY

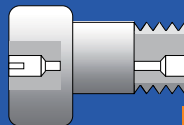

SUS/INOX



CFH..M



CFH..VM

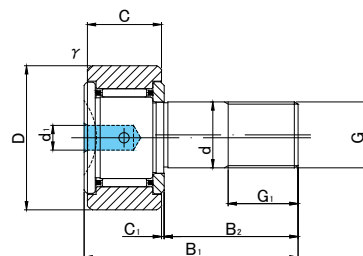

CFH5(V)M~CFH10-1(V)M

CFH..M TYPE

Stud diameter (mm)	h7 tolerance	Designation				Dimensions (mm)						
		Cylindrical outer ring		Crowned outer ring R250(CF5) R500(CF6 ~ CF18)		D	C	d	G	G1	B1	B2
		Without seals	With seals	Without seals	With seals							
5	0 -0.012	CFH 5M	CFH 5MUU	CFH 5MR	CFH 5MUUR	13	9	5	M5×0.8	7.5	23	13
		CFH 5VM	CFH 5VMUU	CFH 5VMR	CFH 5VMUUR							
6	0 -0.012	CFH 6M	CFH 6MUU	CFH 6MR	CFH 6MUUR	16	11	6	M6×1	8	28	16
		CFH 6VM	CFH 6VMUU	CFH 6VMR	CFH 6VMUUR							
8	0 -0.015	CFH 8M	CFH 8MUU	CFH 8MR	CFH 8MUUR	19	11	8	M8×1.25	10	32	20
		CFH 8VM	CFH 8VMUU	CFH 8VMR	CFH 8VMUUR							
10	0 -0.015	CFH10M	CFH10MUU	CFH10MR	CFH10MUUR	22	12	10	M10×1.25	12	36	23
		CFH10VM	CFH10VMUU	CFH10VMR	CFH10VMUUR							
10	0 -0.015	CFH10-1M	CFH10-1MUU	CFH10-1MR	CFH10-1MUUR	26	12	10	M10×1.25	12	36	23
		CFH10-1VM	CFH10-1VMUU	CFH10-1VMR	CFH10-1VMUUR							
12	0 -0.018	CFH12M	CFH12MUU	CFH12MR	CFH12MUUR	30	14	12	M12×1.5	13	40	25
		CFH12VM	CFH12VMUU	CFH12VMR	CFH12VMUUR							
12	0 -0.018	CFH12-1M	CFH12-1MUU	CFH12-1MR	CFH12-1MUUR	32	14	12	M12×1.5	13	40	25
		CFH12-1VM	CFH12-1VMUU	CFH12-1VMR	CFH12-1VMUUR							
16	0 -0.018	CFH16M	CFH16MUU	CFH16MR	CFH16MUUR	35	18	16	M16×1.5	17	52	32.5
		CFH16VM	CFH16VMUU	CFH16VMR	CFH16VMUUR							
18	0 -0.018	CFH18M	CFH18MUU	CFH18MR	CFH18MUUR	40	20	18	M18×1.5	19	58	36.5
		CFH18VM	CFH18VMUU	CFH18VMR	CFH18VMUUR							

* Without seals, suitable for grease lubrication. In case of oil lubrication, up to 130% of this value shall be permissible, and 70% of this value shall apply for types with seals.

OUTER RINGS TOLERANCE (μm)





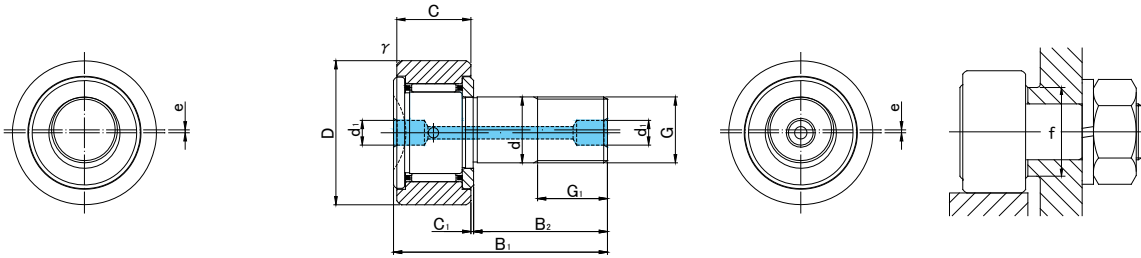





TYPE	Cylindrical outer ring	Crowned outer ring
CF5M,CF6M	0/-8	0/-50
CF8M,CF10M,CF10-1M,CF12M	0/-9	0/-50
CF12-1M,CF16M,CF18M,CF20-1M	0/-11	0/-50
CF20M,CF24M,CF24-1M,CF30M	0/-13	0/-50
CF30-1M,CF30-2M	0/-15	0/-50





CFH12(V)M~CFH18(V)M

Prepacked Grease

					Basic dynamic load rating	Basic static load rating	Largest permissible load	Limiting speed *	Track load capacity		Max tightening torque	Mass
 												
C1	d1	<i>r</i> s min	e	f min	Cr N	Cor N	N	rpm	Cylindrical outer ring N	Crowned outer ring N	N·m	g (approx)
0.5	3.1	0.3	0.2	9.7	2 880	2 540	1 420	29 000	2 250	780	2	10.5
					4 690	5 060	1 420	11 600				
0.6	4	0.3	0.25	11	3 330	3 330	2 110	25 000	3 430	1 080	3	18.5
					6 400	7 840	2 110	12 000				
0.6	4	0.3	0.25	13	3 960	4 330	4 710	20 000	4 020	1 370	8	28.5
					7 470	10 270	4 710	9 000				
0.6	4	0.3	0.3	15	4 950	6 310	6 860	17 000	4 700	1 670	15	45
					8 740	13 340	7 450	7 500				
0.6	4	0.3	0.3	15	4 950	6 310	6 860	17 000	5 490	2 060	15	60
					8 740	13 340	7 450	7 500				
0.6	6	0.6	0.4	20	7 300	9 010	9 800	14 000	7 060	2 450	22	95
					12 350	18 120	11 270	6 000				
0.6	6	0.6	0.4	20	7 300	9 010	9 800	14 000	7 450	2 740	22	105
					12 350	18 120	11 270	6 000				
0.8	6	0.6	0.5	24	11 080	16 860	18 330	10 000	11 200	3 140	58	170
					19 020	34 610	19 800	4 500				
0.8	6	1	0.6	26	13 520	23 180	25 200	8 500	14 400	3 720	87	250
					23 250	47 240	26 560	3 500				

CFH..M



ACCESSORIES

TYPE	 STOP PLUG	 RESIN PLUG	 NUT
CF5M	—	—	Attached
CF6M/CF8M/CF10M/CF10-1M	—	φ 4 Attached	Attached
CF12M/CF12-1M/CF16M/CF18M	φ 6 Attached	φ 6 Attached	Attached
CF20M/CF20-1M/CF24M/CF24-1M/CF30M/CF30-1M/CF30-2M	φ 8 Attached	φ 8 Attached	Attached

CAM FOLLOWERS STAINLESS STEEL

SOLID ECCENTRIC TYPE
SCREWDRIVER SLOT HEAD

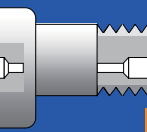
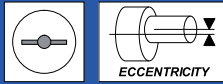

SUS/INOX



CFH..M



CFH..VM

CFH..M TYPE

Stud diameter (mm)	h7 tolerance	Designation				Dimensions (mm)						
		Cylindrical outer ring		Crowned outer ring R1000(CF20 ≤)		D	C	d	G	G1	B1	B2
		Without seals	With seals	Without seals	With seals							
20	0 -0.021	CFH20M	CFH20MUU	CFH20MR	CFH20MUUR	52	24	20	M20×1.5	21	66	40.5
		CFH20VM	CFH20VMUU	CFH20VMR	CFH20VMUUR							
20	0 -0.021	CFH20-1M	CFH20-1MUU	CFH20-1MR	CFH20-1MUUR	47	24	20	M20×1.5	21	66	40.5
		CFH20-1VM	CFH20-1VMUU	CFH20-1VMR	CFH20-1VMUUR							
24	0 -0.021	CFH24M	CFH24MUU	CFH24MR	CFH24MUUR	62	29	24	M24×1.5	25	80	49.5
		CFH24VM	CFH24VMUU	CFH24VMR	CFH24VMUUR							
24	0 -0.021	CFH24-1M	CFH24-1MUU	CFH24-1MR	CFH24-1MUUR	72	29	24	M24×1.5	25	80	49.5
		CFH24-1VM	CFH24-1VMUU	CFH24-1VMR	CFH24-1VMUUR							
30	0 -0.021	CFH30M	CFH30MUU	CFH30MR	CFH30MUUR	80	35	30	M30×1.5	32	100	63
		CFH30VM	CFH30VMUU	CFH30VMR	CFH30VMUUR							
30	0 -0.021	CFH30-1M	CFH30-1MUU	CFH30-1MR	CFH30-1MUUR	85	35	30	M30×1.5	32	100	63
		CFH30-1VM	CFH30-1VMUU	CFH30-1VMR	CFH30-1VMUUR							
30	0 -0.021	CFH30-2M	CFH30-2MUU	CFH30-2MR	CFH30-2MUUR	90	35	30	M30×1.5	32	100	63
		CFH30-2VM	CFH30-2VMUU	CFH30-2VMR	CFH30-2VMUUR							

* Without seals, suitable for grease lubrication. In case of oil lubrication, up to 130% of this value shall be permissible, and 70% of this value shall apply for types with seals.

OUTER RINGS TOLERANCE (μm)

TYPE	Cylindrical outer ring	Crowned outer ring
CF5M,CF6M	0/-8	0/-50
CF8M,CF10M,CF10-1M,CF12M	0/-9	0/-50
CF12-1M,CF16M,CF18M,CF20-1M	0/-11	0/-50
CF20M,CF24M,CF24-1M,CF30M	0/-13	0/-50
CF30-1M,CF30-2M	0/-15	0/-50



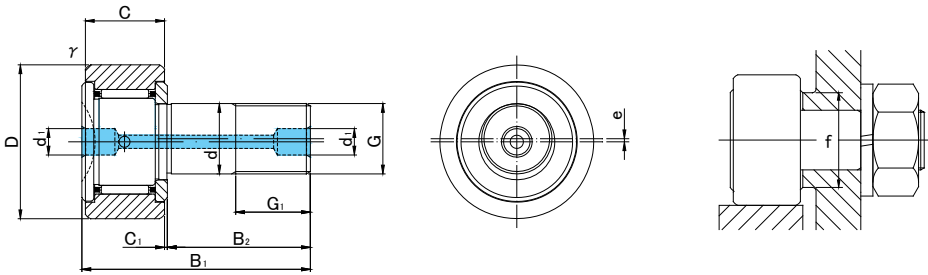

Prepacked Grease

					Basic dynamic load rating	Basic static load rating	Largest permissible load	Limiting speed *	Track load capacity		Max tightening torque	Mass
C1	d1	<i>r</i> s min	e	f min	Cr N	Cor N	N	rpm	Cylindrical outer ring N	Crowned outer ring N	N·m	g (approx)
0.8	8	1	0.7	36	19 020	31 830	32 140	7 000	23 200	8 230	120	460
					30 470	59 320	32 140	3 500				
0.8	8	1	0.7	36	19 020	31 830	32 140	7 000	21 000	7 150	120	385
					30 470	59 320	32 140	3 500				
0.8	8	1	0.8	40	28 040	48 410	49 500	6 500	34 200	10 500	220	815
					42 820	84 650	49 500	3 000				
0.8	8	1	0.8	40	28 040	48 410	49 500	6 500	39 800	12 900	220	1 140
					42 820	84 650	49 500	3 000				
1	8	1	1	46	41 740	78 250	73 700	5 000	52 600	14 900	450	1 870
					62 210	132 530	73 700	2 200				
1	8	1	1	46	41 740	78 250	73 700	5 000	56 000	16 100	450	2 030
					62 210	132 530	73 700	2 200				
1	8	1	1	46	41 740	78 250	73 700	5 000	59 300	17 300	450	2 220
					62 210	132 530	73 700	2 200				

CFH..M

ACCESSORIES

TYPE			
	STOP PLUG	RESIN PLUG	NUT
CF5M	—	—	Attached
CF6M/CF8M/CF10M/CF10-1M	—	φ 4 Attached	Attached
CF12M/CF12-1M/CF16M/CF18M	φ 6 Attached	φ 6 Attached	Attached
CF20M/CF20-1M/CF24M/CF24-1M/CF30M/CF30-1M/CF30-2M	φ 8 Attached	φ 8 Attached	Attached

CAM FOLLOWERS STAINLESS STEEL

SOLID ECCENTRIC TYPE
HEXAGON SOCKET ON THREAD SIDE
SCREWDRIVER SLOT HEAD

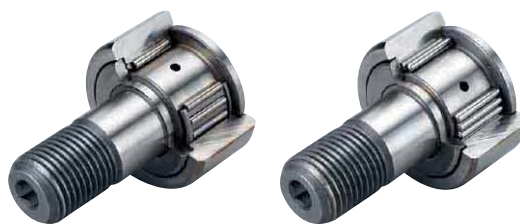
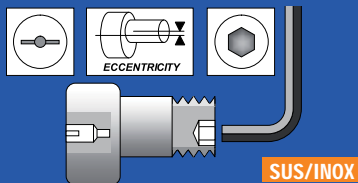

CFH..MB

CFH..VMB

CFH..MB TYPE

Stud diameter (mm)	Designation					Dimensions (mm)							
	h7 tolerance	Cylindrical outer ring		Crowned outer ring R500(CF12 ~ CF18) R1000(CF20 ≤)		D	C	d	G	G1	B1	B2	
		Without seals	With seals	Without seals	With seals								
12	0 -0.018	CFH12MB	CFH12MUUB	CFH12MRB	CFH12MUURB	30	14	12	M12×1.5	13	40	25	
		CFH12VMB	CFH12VMUUB	CFH12VMRB	CFH12VMUURB								
12	0 -0.018	CFH12-1MB	CFH12-1MUUB	CFH12-1MRB	CFH12-1MUURB	32	14	12	M12×1.5	13	40	25	
		CFH12-1VMB	CFH12-1VMUUB	CFH12-1VMRB	CFH12-1VMUURB								
16	0 -0.018	CFH16MB	CFH16MUUB	CFH16MRB	CFH16MUURB	35	18	16	M16×1.5	17	52	32.5	
		CFH16VMB	CFH16VMUUB	CFH16VMRB	CFH16VMUURB								
18	0 -0.018	CFH18MB	CFH18MUUB	CFH18MRB	CFH18MUURB	40	20	18	M18×1.5	19	58	36.5	
		CFH18VMB	CFH18VMUUB	CFH18VMRB	CFH18VMUURB								
20	0 -0.021	CFH20MB	CFH20MUUB	CFH20MRB	CFH20MUURB	52	24	20	M20×1.5	21	66	40.5	
		CFH20VMB	CFH20VMUUB	CFH20VMRB	CFH20VMUURB								
20	0 -0.021	CFH20-1MB	CFH20-1MUUB	CFH20-1MRB	CFH20-1MUURB	47	24	20	M20×1.5	21	66	40.5	
		CFH20-1VMB	CFH20-1VMUUB	CFH20-1VMRB	CFH20-1VMUURB								
24	0 -0.021	CFH24MB	CFH24MUUB	CFH24MRB	CFH24MUURB	62	29	24	M24×1.5	25	80	49.5	
		CFH24VMB	CFH24VMUUB	CFH24VMRB	CFH24VMUURB								
24	0 -0.021	CFH24-1MB	CFH24-1MUUB	CFH24-1MRB	CFH24-1MUURB	72	29	24	M24×1.5	25	80	49.5	
		CFH24-1VMB	CFH24-1VMUUB	CFH24-1VMRB	CFH24-1VMUURB								
30	0 -0.021	CFH30MB	CFH30MUUB	CFH30MRB	CFH30MUURB	80	35	30	M30×1.5	32	100	63	
		CFH30VMB	CFH30VMUUB	CFH30VMRB	CFH30VMUURB								
30	0 -0.021	CFH30-1MB	CFH30-1MUUB	CFH30-1MRB	CFH30-1MUURB	85	35	30	M30×1.5	32	100	63	
		CFH30-1VMB	CFH30-1VMUUB	CFH30-1VMRB	CFH30-1VMUURB								
30	0 -0.021	CFH30-2MB	CFH30-2MUUB	CFH30-2MRB	CFH30-2MUURB	90	35	30	M30×1.5	32	100	63	
		CFH30-2VMB	CFH30-2VMUUB	CFH30-2VMRB	CFH30-2VMUURB								

* Without seals, suitable for grease lubrication. In case of oil lubrication, up to 130% of this value shall be permissible, and 70% of this value shall apply for types with seals.

OUTER RINGS TOLERANCE (μm)

TYPE	Cylindrical outer ring	Crowned outer ring
CF12M	0/-9	0/-50
CF12-1M,CF16M,CF18M,CF20-1M	0/-11	0/-50
CF20M,CF24M,CF24-1M,CF30M	0/-13	0/-50
CF30-1M,CF30-2M	0/-15	0/-50



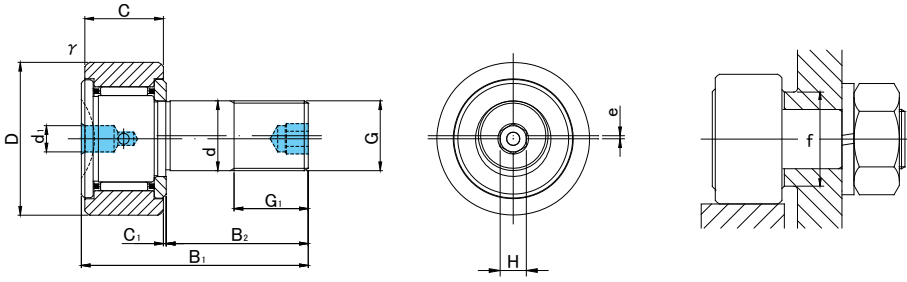

Prepacked Grease

						Basic dynamic load rating	Basic static load rating	Largest permissible load	Limiting speed *	Track load capacity		Max tightening torque	Mass
C1	d1	H	r/s min	e	f min	Cr N	Cor N	N	rpm	Cylindrical outer ring N	Crowned outer ring N	N·m	g (approx)
0.6	6	6	0.6	0.4	20	7 300	9 010	9 800	14 000	7 060	2 450	22	95
						12 350	18 120	11 270	6 000				
0.6	6	6	0.6	0.4	20	7 300	9 010	9 800	14 000	7 450	2 740	22	105
						12 350	18 120	11 270	6 000				
0.8	6	6	0.6	0.5	24	11 080	16 860	18 330	10 000	11 200	3 140	58	170
						19 020	34 610	19 800	4 500				
0.8	6	6	1	0.6	26	13 520	23 180	25 200	8 500	14 400	3 720	87	250
						23 250	47 240	26 560	3 500				
0.8	8	8	1	0.7	36	19 020	31 830	32 140	7 000	23 200	8 230	120	460
						30 470	59 320	32 140	3 500				
0.8	8	8	1	0.7	36	19 020	31 830	32 140	7 000	21 000	7 150	120	385
						30 470	59 320	32 140	3 500				
0.8	8	8	1	0.8	40	28 040	48 410	49 500	6 500	34 200	10 500	220	815
						42 820	84 650	49 500	3 000				
0.8	8	8	1	0.8	40	28 040	48 410	49 500	6 500	39 800	12 900	220	1 140
						42 820	84 650	49 500	3 000				
1	8	8	1	1	46	41 740	78 250	73 700	5 000	52 600	14 900	450	1 870
						62 210	132 530	73 700	2 200				
1	8	8	1	1	46	41 740	78 250	73 700	5 000	56 000	16 100	450	2 030
						62 210	132 530	73 700	2 200				
1	8	8	1	1	46	41 740	78 250	73 700	5 000	59 300	17 300	450	2 220
						62 210	132 530	73 700	2 200				

CFH..MB



ACCESSORIES

TYPE			
CF12M/CF12-1M/CF16M/CF18M	φ 6 Attached	φ 6 Attached	Attached
CF20M/CF20-1M/CF24M/CF24-1M/CF30M/CF30-1M/CF30-2M	φ 8 Attached	φ 8 Attached	Attached

CAM FOLLOWERS STAINLESS STEEL

TAP HOLE FOR PIPING
SCREWDRIVER SLOT HEAD

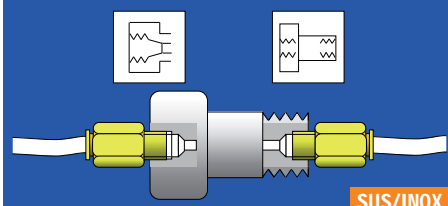

CFT..M



CFT..VM

CFT..M TYPE

Stud diameter (mm)	h7 tolerance	Designation				Dimensions (mm)							
		Cylindrical outer ring		Crowned outer ring R500(CF6 ~ CF18)		D	C	d	G	G1	B1	B2	B3
		Without seals	With seals	Without seals	With seals								
6	0 -0.012	CFT 6M	CFT 6MUU	CFT 6MR	CFT 6MUUR	16	11	6	M6×1	8	28	16	—
		CFT 6VM	CFT 6VMUU	CFT 6VMR	CFT 6VMUUR								
8	0 -0.015	CFT 8M	CFT 8MUU	CFT 8MR	CFT 8MUUR	19	11	8	M8×1.25	10	32	20	—
		CFT 8VM	CFT 8VMUU	CFT 8VMR	CFT 8VMUUR								
10	0 -0.015	CFT10M	CFT10MUU	CFT10MR	CFT10MUUR	22	12	10	M10×1.25	12	36	23	—
		CFT10VM	CFT10VMUU	CFT10VMR	CFT10VMUUR								
10	0 -0.015	CFT10-1M	CFT10-1MUU	CFT10-1MR	CFT10-1MUUR	26	12	10	M10×1.25	12	36	23	—
		CFT10-1VM	CFT10-1VMUU	CFT10-1VMR	CFT10-1VMUUR								
12	0 -0.018	CFT12M	CFT12MUU	CFT12MR	CFT12MUUR	30	14	12	M12×1.5	13	40	25	6
		CFT12VM	CFT12VMUU	CFT12VMR	CFT12VMUUR								
12	0 -0.018	CFT12-1M	CFT12-1MUU	CFT12-1MR	CFT12-1MUUR	32	14	12	M12×1.5	13	40	25	6
		CFT12-1VM	CFT12-1VMUU	CFT12-1VMR	CFT12-1VMUUR								
16	0 -0.018	CFT16M	CFT16MUU	CFT16MR	CFT16MUUR	35	18	16	M16×1.5	17	52	32.5	8
		CFT16VM	CFT16VMUU	CFT16VMR	CFT16VMUUR								
18	0 -0.018	CFT18M	CFT18MUU	CFT18MR	CFT18MUUR	40	20	18	M18×1.5	19	58	36.5	8
		CFT18VM	CFT18VMUU	CFT18VMR	CFT18VMUUR								

* Without seals, suitable for grease lubrication. In case of oil lubrication, up to 130% of this value shall be permissible, and 70% of this value shall apply for types with seals.

OUTER RINGS TOLERANCE (μm)

TYPE	Cylindrical outer ring	Crowned outer ring
CF6M	0/-8	0/-50
CF8M,CF10M,CF10-1M,CF12M	0/-9	0/-50
CF12-1M,CF16M,CF18M,CF20-1M	0/-11	0/-50
CF20M,CF24M,CF24-1M,CF30M	0/-13	0/-50
CF30-1M,CF30-2M	0/-15	0/-50



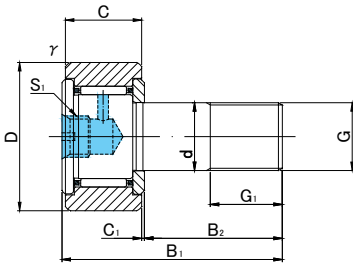

CFT6(V)M~CFT10-1(V)M

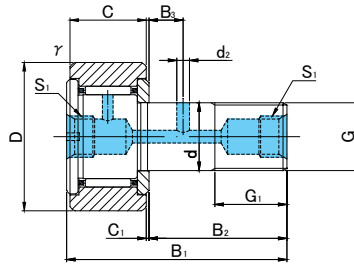

CFT12(V)M~CFT18(V)M

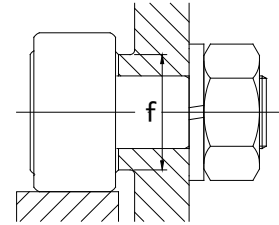

Prepacked Grease

					Basic dynamic load rating	Basic static load rating	Largest permissible load	Limiting speed *	Track load capacity		Max tightening torque	Mass
C1	S1	d2	f/s min	f min	Cr N	Cor N	N	rpm	Cylindrical outer ring N	Crowned outer ring N	N·m	g (approx)
0.6	M6×0.75	—	0.3	11	3 330	3 330	2 110	25 000	3 430	1 080	3	18.5
					6 400	7 840	2 110	12 000				
0.6	M6×0.75	—	0.3	13	3 960	4 330	4 710	20 000	4 020	1 370	8	28.5
					7 470	10 270	4 710	9 000				
0.6	M6×0.75	—	0.3	15	4 950	6 310	6 860	17 000	4 700	1 670	15	45
					8 740	13 340	7 450	7 500				
0.6	M6×0.75	—	0.3	15	4 950	6 310	6 860	17 000	5 490	2 060	15	60
					8 740	13 340	7 450	7 500				
0.6	M6×0.75	3	0.6	20	7 300	9 010	7 840	14 000	7 060	2 450	22	95
					12 350	18 120	9 010	6 000				
0.6	M6×0.75	3	0.6	20	7 300	9 010	7 840	14 000	7 450	2 740	22	105
					12 350	18 120	9 010	6 000				
0.8	Rc1/8	3	0.6	24	11 080	16 860	14 660	10 000	11 200	3 140	58	170
					19 020	34 610	15 840	4 500				
0.8	Rc1/8	3	1	26	13 520	23 180	20 160	8 500	14 400	3 720	87	250
					23 250	47 240	21 240	3 500				

CFT..M



ACCESSORIES

TYPE	
All types	Attached

CAM FOLLOWERS STAINLESS STEEL

TAP HOLE FOR PIPING
SCREWDRIVER SLOT HEAD

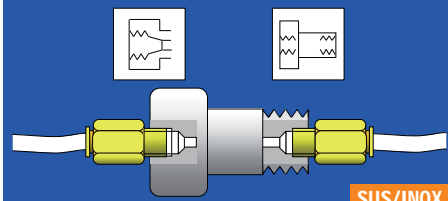

CFT..M



CFT..VM

CFT..M TYPE

Stud diameter (mm)	h7 tolerance	Designation				Dimensions (mm)							
		Cylindrical outer ring		Crowned outer ring R1000(CF20 ≤)		D	C	d	G	G1	B1	B2	B3
		Without seals	With seals	Without seals	With seals								
20	0 -0.021	CFT20M	CFT20MUU	CFT20MR	CFT20MUUR	52	24	20	M20×1.5	21	66	40.5	9
		CFT20VM	CFT20VMUU	CFT20VMR	CFT20VMUUR								
20	0 -0.021	CFT20-1M	CFT20-1MUU	CFT20-1MR	CFT20-1MUUR	47	24	20	M20×1.5	21	66	40.5	9
		CFT20-1VM	CFT20-1VMUU	CFT20-1VMR	CFT20-1VMUUR								
24	0 -0.021	CFT24M	CFT24MUU	CFT24MR	CFT24MUUR	62	29	24	M24×1.5	25	80	49.5	11
		CFT24VM	CFT24VMUU	CFT24VMR	CFT24VMUUR								
24	0 -0.021	CFT24-1M	CFT24-1MUU	CFT24-1MR	CFT24-1MUUR	72	29	24	M24×1.5	25	80	49.5	11
		CFT24-1VM	CFT24-1VMUU	CFT24-1VMR	CFT24-1VMUUR								
30	0 -0.021	CFT30M	CFT30MUU	CFT30MR	CFT30MUUR	80	35	30	M30×1.5	32	100	63	15
		CFT30VM	CFT30VMUU	CFT30VMR	CFT30VMUUR								
30	0 -0.021	CFT30-1M	CFT30-1MUU	CFT30-1MR	CFT30-1MUUR	85	35	30	M30×1.5	32	100	63	15
		CFT30-1VM	CFT30-1VMUU	CFT30-1VMR	CFT30-1VMUUR								
30	0 -0.021	CFT30-2M	CFT30-2MUU	CFT30-2MR	CFT30-2MUUR	90	35	30	M30×1.5	32	100	63	15
		CFT30-2VM	CFT30-2VMUU	CFT30-2VMR	CFT30-2VMUUR								

* Without seals, suitable for grease lubrication. In case of oil lubrication, up to 130% of this value shall be permissible, and 70% of this value shall apply for types with seals.

OUTER RINGS TOLERANCE (μm)

TYPE	Cylindrical outer ring	Crowned outer ring
CF6M	0/-8	0/-50
CF8M,CF10M,CF10-1M,CF12M	0/-9	0/-50
CF12-1M,CF16M,CF18M,CF20-1M	0/-11	0/-50
CF20M,CF24M,CF24-1M,CF30M	0/-13	0/-50
CF30-1M,CF30-2M	0/-15	0/-50

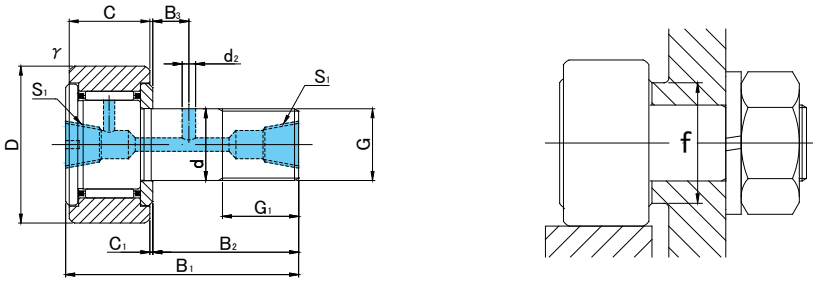

Prepacked Grease

					Basic dynamic load rating	Basic static load rating	Largest permissible load	Limiting speed *	Track load capacity		Max tightening torque	Mass
C1	S1	d2	f/s min	f min	Cr N	Cor N	N	rpm	Cylindrical outer ring N	Crowned outer ring N	N·m	g (approx)
0.8	Rc1/8	4	1	36	19 020	31 830	25 710	7 000	23 200	8 230	120	460
					30 470	59 320	25 710	3 500				
0.8	Rc1/8	4	1	36	19 020	31 830	25 710	7 000	21 000	7 150	120	385
					30 470	59 320	25 710	3 500				
0.8	Rc1/8	4	1	40	28 040	48 410	39 600	6 500	34 200	10 500	220	815
					42 820	84 650	39 600	3 000				
0.8	Rc1/8	4	1	40	28 040	48 410	39 600	6 500	39 800	12 900	220	1 140
					42 820	84 650	39 600	3 000				
1	Rc1/8	4	1	46	41 740	78 250	58 960	5 000	52 600	14 900	450	1 870
					62 210	132 530	58 960	2 200				
1	Rc1/8	4	1	46	41 740	78 250	58 960	5 000	56 000	56 000	450	2 030
					62 210	132 530	58 960	2 200				
1	Rc1/8	4	1	46	41 740	78 250	58 960	5 000	59 300	59 300	450	2 220
					62 210	132 530	58 960	2 200				

CFT..M



ACCESSORIES

TYPE	
All types	NUT Attached

CAM FOLLOWERS STAINLESS STEEL

TAP HOLE FOR PIPING
HEXAGON SOCKET ON STUD HEAD

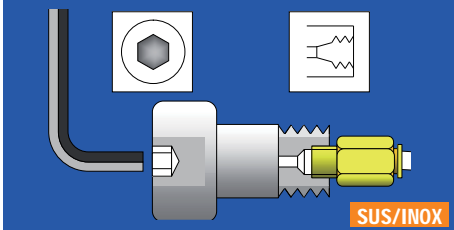

SUS/INOX



CFT..MA



CFT..VMA

CFT..MA TYPE

Stud diameter (mm)	h7 tolerance	Designation				Dimensions (mm)							
		Cylindrical outer ring		Crowned outer ring R500(CF12 ~ CF18) R1000(CF20 ≤)		D	C	d	G	G1	B1	B2	B3
		Without seals	With seals	Without seals	With seals								
12	0 -0.018	CFT12MA	CFT12MUUA	CFT12MRA	CFT12MUURA	30	14	12	M12×1.5	13	40	25	6
		CFT12VMA	CFT12VMUUA	CFT12VMRA	CFT12VMUURA								
12	0 -0.018	CFT12-1MA	CFT12-1MUUA	CFT12-1MRA	CFT12-1MUURA	32	14	12	M12×1.5	13	40	25	6
		CFT12-1VMA	CFT12-1VMUUA	CFT12-1VMRA	CFT12-1VMUURA								
16	0 -0.018	CFT16MA	CFT16MUUA	CFT16MRA	CFT16MUURA	35	18	16	M16×1.5	17	52	32.5	8
		CFT16VMA	CFT16VMUUA	CFT16VMRA	CFT16VMUURA								
18	0 -0.018	CFT18MA	CFT18MUUA	CFT18MRA	CFT18MUURA	40	20	18	M18×1.5	19	58	36.5	8
		CFT18VMA	CFT18VMUUA	CFT18VMRA	CFT18VMUURA								
20	0 -0.021	CFT20MA	CFT20MUUA	CFT20MRA	CFT20MUURA	52	24	20	M20×1.5	21	66	40.5	9
		CFT20VMA	CFT20VMUUA	CFT20VMRA	CFT20VMUURA								
20	0 -0.021	CFT20-1MA	CFT20-1MUUA	CFT20-1MRA	CFT20-1MUURA	47	24	20	M20×1.5	21	66	40.5	9
		CFT20-1VMA	CFT20-1VMUUA	CFT20-1VMRA	CFT20-1VMUURA								
24	0 -0.021	CFT24MA	CFT24MUUA	CFT24MRA	CFT24MUURA	62	29	24	M24×1.5	25	80	49.5	11
		CFT24VMA	CFT24VMUUA	CFT24VMRA	CFT24VMUURA								
24	0 -0.021	CFT24-1MA	CFT24-1MUUA	CFT24-1MRA	CFT24-1MUURA	72	29	24	M24×1.5	25	80	49.5	11
		CFT24-1VMA	CFT24-1VMUUA	CFT24-1VMRA	CFT24-1VMUURA								
30	0 -0.021	CFT30MA	CFT30MUUA	CFT30MRA	CFT30MUURA	80	35	30	M30×1.5	32	100	63	15
		CFT30VMA	CFT30VMUUA	CFT30VMRA	CFT30VMUURA								
30	0 -0.021	CFT30-1MA	CFT30-1MUUA	CFT30-1MRA	CFT30-1MUURA	85	35	30	M30×1.5	32	100	63	15
		CFT30-1VMA	CFT30-1VMUUA	CFT30-1VMRA	CFT30-1VMUURA								
30	0 -0.021	CFT30-2MA	CFT30-2MUUA	CFT30-2MRA	CFT30-2MUURA	90	35	30	M30×1.5	32	100	63	15
		CFT30-2VMA	CFT30-2VMUUA	CFT30-2VMRA	CFT30-2VMUURA								

* Without seals, suitable for grease lubrication. In case of oil lubrication, up to 130% of this value shall be permissible, and 70% of this value shall apply for types with seals.

OUTER RINGS TOLERANCE (μm)

TYPE	Cylindrical outer ring	Crowned outer ring
CF12M	0/-9	0/-50
CF12-1M,CF16M,CF18M,CF20-1M	0/-11	0/-50
CF20M,CF24M,CF24-1M,CF30M	0/-13	0/-50
CF30-1M,CF30-2M	0/-15	0/-50



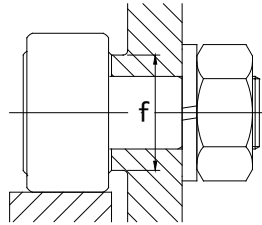
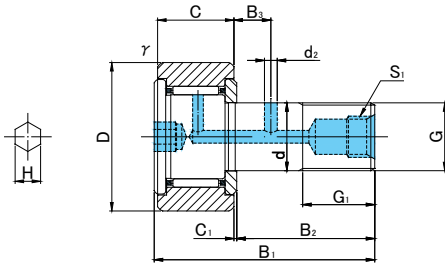

Prepacked Grease

						Basic dynamic load rating	Basic static load rating	Largest permissible load	Limiting speed *	Track load capacity		Max tightening torque	Mass
C1	S1	d2	H	r/s min	f min	Cr N	Cor N	N	rpm	Cylindrical outer ring N	Crowned outer ring N	N·m	g (approx)
0.6	M6×0.75	3	6	0.6	20	7 300	9 010	7 840	14 000	7 060	2 450	22	95
						12 350	18 120	9 010	6 000				
0.6	M6×0.75	3	6	0.6	20	7 300	9 010	7 840	14 000	7 450	2 740	22	105
						12 350	18 120	9 010	6 000				
0.8	Rc1/8	3	6	0.6	24	11 080	16 860	14 660	10 000	11 200	3 140	58	170
						19 020	34 610	15 840	4 500				
0.8	Rc1/8	3	6	1	26	13 520	23 180	20 160	8 500	14 400	3 720	87	250
						23 250	47 240	21 240	3 500				
0.8	Rc1/8	4	8	1	36	19 020	31 830	25 710	7 000	23 200	8 230	120	460
						30 470	59 320	25 710	3 500				
0.8	Rc1/8	4	8	1	36	19 020	31 830	25 710	7 000	21 000	7 150	120	385
						30 470	59 320	25 710	3 500				
0.8	Rc1/8	4	8	1	40	28 040	48 410	39 600	6 500	34 200	10 500	220	815
						42 820	84 650	39 600	3 000				
0.8	Rc1/8	4	8	1	40	28 040	48 410	39 600	6 500	39 800	12 900	220	1 140
						42 820	84 650	39 600	3 000				
1	Rc1/8	4	8	1	46	41 740	78 250	58 960	5 000	52 600	14 900	450	1 870
						62 210	132 530	58 960	2 200				
1	Rc1/8	4	8	1	46	41 740	78 250	58 960	5 000	56 000	56 000	450	2 030
						62 210	132 530	58 960	2 200				
1	Rc1/8	4	8	1	46	41 740	78 250	58 960	5 000	59 300	59 300	450	2 220
						62 210	132 530	58 960	2 200				

CFT..MA



ACCESSORIES

TYPE	
All types	NUT Attached

ROLLER FOLLOWERS

STAINLESS STEEL



ROLLER FOLLOWERS STAINLESS STEEL

SEPARABLE
WITHOUT INNER RING







SUS/INOX



RNAST..M

RNAST..M TYPE

Shaft Diameter (mm)	Designation		Dimensions (mm)			
	Cylindrical outer ring 	Crowned outer ring (R500) 				
7	RNAST 5M	RNAST 5MR	7 $\begin{matrix} +0.022 \\ +0.013 \end{matrix}$	16	7.8	
10	RNAST 6M	RNAST 6MR	10 $\begin{matrix} +0.027 \\ +0.016 \end{matrix}$	19	9.8	
12	RNAST 8M	RNAST 8MR	12 $\begin{matrix} +0.027 \\ +0.016 \end{matrix}$	24	9.8	
14	RNAST10M	RNAST10MR	14 $\begin{matrix} +0.027 \\ +0.016 \end{matrix}$	30	11.8	
16	RNAST12M	RNAST12MR	16 $\begin{matrix} +0.027 \\ +0.016 \end{matrix}$	32	11.8	
20	RNAST15M	RNAST15MR	20 $\begin{matrix} +0.033 \\ +0.020 \end{matrix}$	35	11.8	
22	RNAST17M	RNAST17MR	22 $\begin{matrix} +0.033 \\ +0.020 \end{matrix}$	40	15.8	
25	RNAST20M	RNAST20MR	25 $\begin{matrix} +0.033 \\ +0.020 \end{matrix}$	47	15.8	
30	RNAST25M	RNAST25MR	30 $\begin{matrix} +0.033 \\ +0.020 \end{matrix}$	52	15.8	
38	RNAST30M	RNAST30MR	38 $\begin{matrix} +0.041 \\ +0.025 \end{matrix}$	62	19.8	
42	RNAST35M	RNAST35MR	42 $\begin{matrix} +0.041 \\ +0.025 \end{matrix}$	72	19.8	
50	RNAST40M	RNAST40MR	50 $\begin{matrix} +0.041 \\ +0.025 \end{matrix}$	80	19.8	
55	RNAST45M	RNAST45MR	55 $\begin{matrix} +0.049 \\ +0.030 \end{matrix}$	85	19.8	
60	RNAST50M	RNAST50MR	60 $\begin{matrix} +0.049 \\ +0.030 \end{matrix}$	90	19.8	

* Suitable for grease lubrication. In case of oil lubrication, up to 130% of this value shall be permissible.

OUTER RINGS TOLERANCE

TYPE	Cylindrical outer ring	Crowned outer ring
RNAST5M	0/-8	0/-50
RNAST6M,RNAST8M,RNAST10M	0/-9	0/-50
RNAST12M,RNAST15M,RNAST17M,RNAST20M	0/-11	0/-50
RNAST25M,RNAST30M,RNAST35M,RNAST40M	0/-13	0/-50
RNAST45M,RNAST50M	0/-15	0/-50



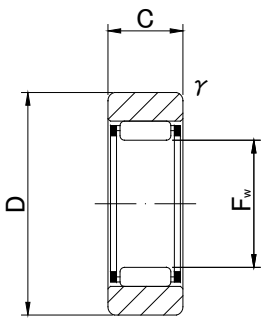



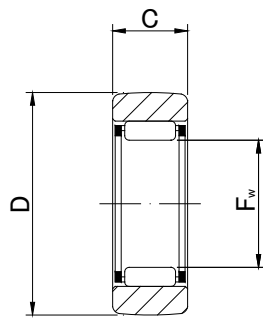



RNAST..M



RNAST..MR

Prepacked Grease

f's min	Basic dynamic load rating	Basic static load rating	Track load capacity		Limiting speed *	Mass
	 Cr N	 Cor N	 Cylindrical outer ring N	 Crowned outer ring N	 rpm	 g (approx)
0.3	2 520	2 190	2 350	1 080	30 000	8.9
0.3	3 790	4 180	3 530	1 370	20 000	13.9
0.6	5 220	5 410	4 020	1 860	17 000	23.5
1	8 920	8 890	5 590	2 450	15 000	42.5
1	9 560	10 020	5 980	2 740	13 000	49.5
1	11 310	13 150	6 570	3 140	10 000	50
1	16 000	19 220	10 900	3 720	9 500	90
1	17 660	22 540	12 700	4 610	8 500	135
1	19 040	26 120	14 100	5 290	7 000	135
1	27 870	41 760	22 100	6 660	5 500	255
1	29 620	46 550	25 700	8 130	5 000	375
1.5	32 840	56 210	26 900	9 310	4 000	420
1.5	34 130	61 080	28 500	10 100	4 000	460
1.5	35 600	66 050	30 200	11 000	3 500	500

RNAST..M



ROLLER FOLLOWERS STAINLESS STEEL

SEPARABLE
WITH INNER RING



SUS/INOX



NAST..M

NAST..M TYPE

Shaft Diameter (mm)	Designation		Dimensions (mm)					
	Cylindrical outer ring	Crowned outer ring (R500)						
			d	D	B	C	r's min	
6	NAST 6M	NAST 6MR	6 ⁰ _{-0.008}	19	10	9.8	0.3	
8	NAST 8M	NAST 8MR	8 ⁰ _{-0.008}	24	10	9.8	0.6	
10	NAST10M	NAST10MR	10 ⁰ _{-0.008}	30	12	11.8	1	
12	NAST12M	NAST12MR	12 ⁰ _{-0.008}	32	12	11.8	1	
15	NAST15M	NAST15MR	15 ⁰ _{-0.008}	35	12	11.8	1	
17	NAST17M	NAST17MR	17 ⁰ _{-0.010}	40	16	15.8	1	
20	NAST20M	NAST20MR	20 ⁰ _{-0.010}	47	16	15.8	1	
25	NAST25M	NAST25MR	25 ⁰ _{-0.010}	52	16	15.8	1	
30	NAST30M	NAST30MR	30 ⁰ _{-0.010}	62	20	19.8	1	
35	NAST35M	NAST35MR	35 ⁰ _{-0.012}	72	20	19.8	1	
40	NAST40M	NAST40MR	40 ⁰ _{-0.012}	80	20	19.8	1.5	
45	NAST45M	NAST45MR	45 ⁰ _{-0.012}	85	20	19.8	1.5	
50	NAST50M	NAST50MR	50 ⁰ _{-0.012}	90	20	19.8	1.5	

* Suitable for grease lubrication. In case of oil lubrication, up to 130% of this value shall be permissible.

OUTER RINGS TOLERANCE (Outside diameter) (μm)

TYPE	Cylindrical outer ring	Crowned outer ring
NAST6M,NAST8M,NAST10M	0/-9	0/-50
NAST12M,NAST15M,NAST17M,NAST20M	0/-11	0/-50
NAST25M,NAST30M,NAST35M,NAST40M	0/-13	0/-50
NAST45M,NAST50M	0/-15	0/-50



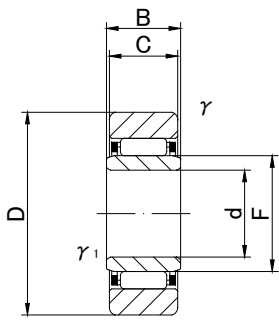

NAST..M

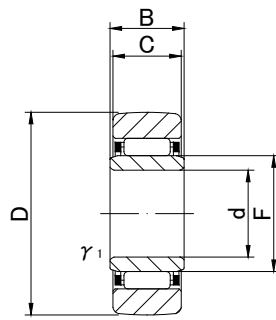

NAST..MR

Prepacked Grease

		Basic dynamic load rating	Basic static load rating	Track load capacity		Limiting speed *	Mass
<i>r</i> 1s min	F	Cr N	Cor N	Cylindrical outer ring N	Crowned outer ring N	rpm	g (approx)
0.3	10	3 790	4 180	3 530	1 370	20 000	17.8
0.3	12	5 220	5 410	4 020	1 860	17 000	28
0.3	14	8 920	8 890	5 590	2 450	15 000	50
0.3	16	9 560	10 020	5 980	2 740	13 000	58
0.3	20	11 310	13 150	6 570	3 140	10 000	62
0.3	22	16 000	19 220	10 900	3 720	9 500	110
0.3	25	17 660	22 540	12 700	4 610	8 500	155
0.3	30	19 040	26 120	14 100	5 290	7 000	180
0.6	38	27 870	41 760	22 100	6 660	5 500	320
0.6	42	29 620	46 550	25 700	8 130	5 000	440
1	50	32 840	56 210	26 900	9 310	4 000	530
1	55	34 130	61 080	28 500	10 100	4 000	580
1	60	35 600	66 050	30 200	11 000	3 500	635

NAST..M



ROLLER FOLLOWERS STAINLESS STEEL

SEPARABLE WITH INNER RING WITH SHIELD



SUS/INOX

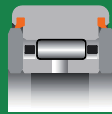

SUS/INOX



NAST..MZZ

NAST..MZZ TYPE

Shaft Diameter (mm)	Designation				Dimensions (mm)			
	Cylindrical outer ring		Crowned outer ring (R500)		d	D	B	C
	Without seals	With seals	Without seals	With seals				
6	NAST 6MZZ	NAST 6MZZUU	NAST 6MZZR	NAST 6MZZUUR	6 ⁰ _{-0.008}	19	14	13.8
8	NAST 8MZZ	NAST 8MZZUU	NAST 8MZZR	NAST 8MZZUUR	8 ⁰ _{-0.008}	24	14	13.8
10	NAST10MZZ	NAST10MZZUU	NAST10MZZR	NAST10MZZUUR	10 ⁰ _{-0.008}	30	16	15.8
12	NAST12MZZ	NAST12MZZUU	NAST12MZZR	NAST12MZZUUR	12 ⁰ _{-0.008}	32	16	15.8
15	NAST15MZZ	NAST15MZZUU	NAST15MZZR	NAST15MZZUUR	15 ⁰ _{-0.008}	35	16	15.8
17	NAST17MZZ	NAST17MZZUU	NAST17MZZR	NAST17MZZUUR	17 ⁰ _{-0.010}	40	20	19.8
20	NAST20MZZ	NAST20MZZUU	NAST20MZZR	NAST20MZZUUR	20 ⁰ _{-0.010}	47	20	19.8
25	NAST25MZZ	NAST25MZZUU	NAST25MZZR	NAST25MZZUUR	25 ⁰ _{-0.010}	52	20	19.8
30	NAST30MZZ	NAST30MZZUU	NAST30MZZR	NAST30MZZUUR	30 ⁰ _{-0.010}	62	25	24.8
35	NAST35MZZ	NAST35MZZUU	NAST35MZZR	NAST35MZZUUR	35 ⁰ _{-0.012}	72	25	24.8
40	NAST40MZZ	NAST40MZZUU	NAST40MZZR	NAST40MZZUUR	40 ⁰ _{-0.012}	80	26	25.8
45	NAST45MZZ	NAST45MZZUU	NAST45MZZR	NAST45MZZUUR	45 ⁰ _{-0.012}	85	26	25.8
50	NAST50MZZ	NAST50MZZUU	NAST50MZZR	NAST50MZZUUR	50 ⁰ _{-0.012}	90	26	25.8

* Without seals, suitable for grease lubrication. In case of oil lubrication, up to 130% of this value shall be permissible, and 70% of this value shall apply for types with seals.

OUTER RINGS TOLERANCE (Outside diameter) (μm)

TYPE	Cylindrical outer ring	Crowned outer ring
NAST6M, NAST8M, NAST10M	0/-9	0/-50
NAST12M, NAST15M, NAST17M, NAST20M	0/-11	0/-50
NAST25M, NAST30M, NAST35M, NAST40M	0/-13	0/-50
NAST45M, NAST50M	0/-15	0/-50



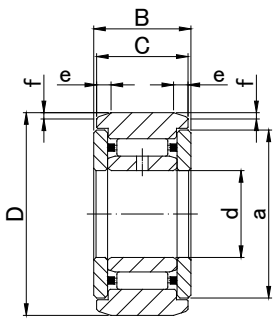

NAST..MZZ

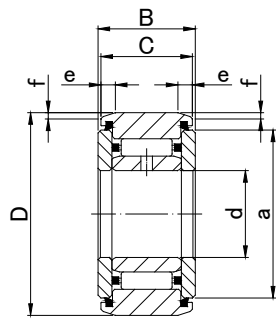

NAST..MZZUU

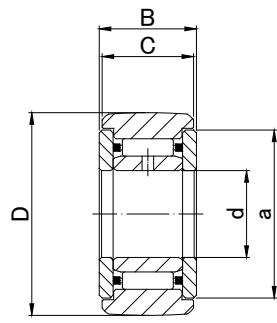

NAST..MZZR

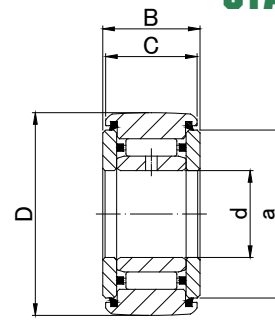

NAST..MZZUUR

Prepacked Grease

				Basic dynamic load rating	Basic static load rating	Track load capacity		Limiting speed *	Mass
a	e	f	r_s min	Cr N	Cor N	Cylindrical outer ring N	Crowned outer ring N	rpm	g (approx)
14	2.5	0.8	0.3	3 790	4 180	3 530	1 370	20 000	24.5
17.5	2.5	0.8	0.6	5 220	5 410	4 510	1 860	17 000	39
23.5	2.5	0.8	1	8 920	8 890	6 860	2 450	15 000	65
25.5	2.5	0.8	1	9 560	10 020	7 350	2 740	13 000	75
29	2.5	0.8	1	11 310	13 150	8 040	3 140	10 000	83
32.5	3	1	1	16 000	19 220	11 800	3 720	9 500	135
38	3	1	1	17 660	22 540	13 800	4 610	8 500	195
43	3	1	1	19 040	26 120	15 300	5 290	7 000	225
50.5	4	1.2	1	27 870	41 760	22 100	6 660	5 500	400
53.5	4	1.2	1	29 620	46 550	25 700	8 130	5 000	550
61.5	4	1.2	1.5	32 840	56 210	30 300	9 310	4 000	710
66.5	4	1.2	1.5	34 130	61 080	31 100	10 100	4 000	760
76	4	1.2	1.5	35 600	66 050	34 000	11 000	3 500	830

NAST..MZZ



ROLLER FOLLOWERS STAINLESS STEEL

NON SEPARABLE WITH INNER RING



SUS/INOX

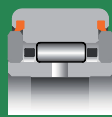

SUS/INOX



NART..MR



NART..VMR

NART.. M TYPE

Shaft Diameter (mm)	Designation				Dimensions (mm)			
	Crowned outer ring R500(≤ NART17R) R1000(NART20R ≤)		Cylindrical outer ring		d	D	B	C
	Without seals	With seals	Without seals	With seals				
5	NART 5MR	NART 5MUUR	NART 5MX	NART 5MUUX	5 0	16	12	11
	NART 5MVR	NART 5MUUVR	NART 5MVX	NART 5MUUVX	5 -0.008	16	12	11
6	NART 6MR	NART 6MUUR	NART 6MX	NART 6MUUX	6 0	19	12	11
	NART 6MVR	NART 6MUUVR	NART 6MVX	NART 6MUUVX	6 -0.008	19	12	11
8	NART 8MR	NART 8MUUR	NART 8MX	NART 8MUUX	8 0	24	15	14
	NART 8MVR	NART 8MUUVR	NART 8MVX	NART 8MUUVX	8 -0.008	24	15	14
10	NART10MR	NART10MUUR	NART10MX	NART10MUUX	10 0	30	15	14
	NART10MVR	NART10MUUVR	NART10MVX	NART10MUUVX	10 -0.008	30	15	14
12	NART12MR	NART12MUUR	NART12MX	NART12MUUX	12 0	32	15	14
	NART12MVR	NART12MUUVR	NART12MVX	NART12MUUVX	12 -0.008	32	15	14
15	NART15MR	NART15MUUR	NART15MX	NART15MUUX	15 0	35	19	18
	NART15MVR	NART15MUUVR	NART15MVX	NART15MUUVX	15 -0.008	35	19	18
17	NART17MR	NART17MUUR	NART17MX	NART17MUUX	17 0	40	21	20
	NART17MVR	NART17MUUVR	NART17MVX	NART17MUUVX	17 -0.008	40	21	20
20	NART20MR	NART20MUUR	NART20MX	NART20MUUX	20 0	47	25	24
	NART20MVR	NART20MUUVR	NART20MVX	NART20MUUVX	20 -0.010	47	25	24
25	NART25MR	NART25MUUR	NART25MX	NART25MUUX	25 0	52	25	24
	NART25MVR	NART25MUUVR	NART25MVX	NART25MUUVX	25 -0.010	52	25	24
30	NART30MR	NART30MUUR	NART30MX	NART30MUUX	30 0	62	29	28
	NART30MVR	NART30MUUVR	NART30MVX	NART30MUUVX	30 -0.010	62	29	28
35	NART35MR	NART35MUUR	NART35MX	NART35MUUX	35 0	72	29	28
	NART35MVR	NART35MUUVR	NART35MVX	NART35MUUVX	35 -0.012	72	29	28
40	NART40MR	NART40MUUR	NART40MX	NART40MUUX	40 0	80	32	30
	NART40MVR	NART40MUUVR	NART40MVX	NART40MUUVX	40 -0.012	80	32	30
45	NART45MR	NART45MUUR	NART45MX	NART45MUUX	45 0	85	32	30
	NART45MVR	NART45MUUVR	NART45MVX	NART45MUUVX	45 -0.012	85	32	30
50	NART50MR	NART50MUUR	NART50MX	NART50MUUX	50 0	90	32	30
	NART50MVR	NART50MUUVR	NART50MVX	NART50MUUVX	50 -0.012	90	32	30

* Without seals, suitable for grease lubrication. In case of oil lubrication, up to 130% of this value shall be permissible, and 70% of this value shall apply for types with seals.

OUTER RINGS TOLERANCE (Outside diameter) (μm)

TYPE	Crowned outer ring	Cylindrical outer ring
NART5M	0/-50	0/-8
NART6M,NART8M,NART10M	0/-50	0/-9
NART12M,NART15M,NART17M,NART20M	0/-50	0/-11
NART25M,NART30M,NART35M,NART40M	0/-50	0/-13
NART45M,NART50M	0/-50	0/-15



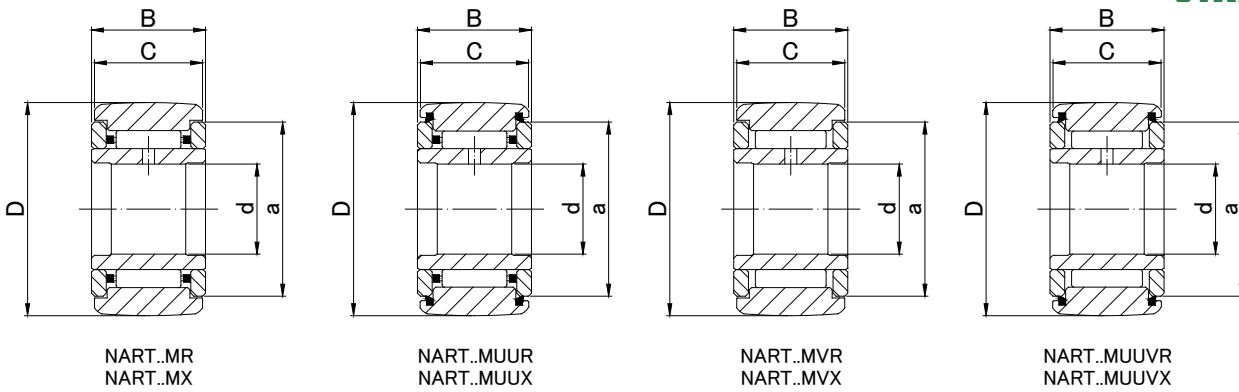

Prepacked Grease

		Basic dynamic load rating	Basic static load rating	Track load capacity		Limiting speed *	Mass
a	r/s min	Cr N	Cor N	Crowned outer ring N	Cylindrical outer ring N	rpm	g (approx)
12	0.3	3 330	3 420	1 080	3 430	25 000	14.5
12	0.3	6 210	7 670	1 080	3 430	8 500	15.1
14	0.3	3 860	4 320	1 370	4 020	20 000	20.5
14	0.3	7 020	9 470	1 370	4 020	7 000	21.5
17.5	0.3	6 070	6 710	1 860	5 950	17 000	41.5
17.5	0.3	10 850	14 350	1 860	5 950	5 500	42.5
23.5	0.6	7 910	7 630	2 450	7 060	15 000	64.5
23.5	0.6	14 350	16 650	2 450	7 060	5 000	66.5
25.5	0.6	8 370	8 460	2 740	7 450	13 000	71
25.5	0.6	15 450	18 860	2 740	7 450	4 500	73
29	0.6	13 240	16 190	3 140	11 200	10 000	102
29	0.6	23 090	33 480	3 140	11 200	3 500	106
32.5	1	17 110	20 700	3 720	14 400	9 500	149
32.5	1	29 440	42 500	3 720	14 400	3 000	155
38	1	22 170	30 080	7 150	21 000	8 000	250
38	1	38 360	61 910	7 150	21 000	2 500	255
43	1	23 730	34 500	8 230	23 200	7 000	285
43	1	41 860	72 680	8 230	23 200	2 500	295
50.5	1	33 300	52 340	10 500	33 000	5 500	470
50.5	1	55 010	101 560	10 500	33 000	1 800	485
53.5	1	35 140	57 770	12 900	38 000	5 000	640
53.5	1	57 960	111 780	12 900	38 000	1 700	655
61.5	1	42 500	77 920	14 900	44 400	4 000	845
61.5	1	70 100	151 060	14 900	44 000	1 400	865
66.5	1	45 350	87 580	16 100	47 000	4 000	915
66.5	1	73 780	166 610	16 100	47 000	1 300	935
76	1	47 010	94 110	17 300	50 000	3 500	980
76	1	77 370	182 160	17 300	50 000	1 200	1 010

NART..M



INTERCHANGE TABLE



MACHINED RING NEEDLE ROLLER BEARINGS WITH INNER RING WITHOUT INNER RING

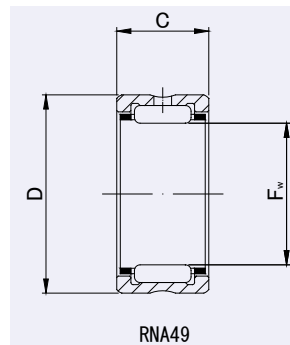
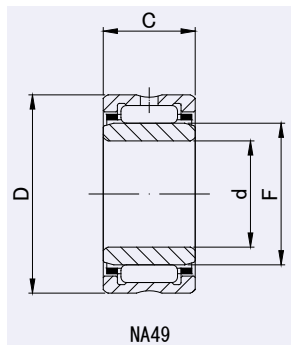

NA49, RNA49

DIMENSION TABLE

JNS NUMBER WITH INNER RING	Mass (Approx.)	JNS NUMBER WITHOUT INNER RING	Mass (Approx.)	JNS NUMBER Assembled INNER RING	Dimensions(mm)				Basic dynamic load rating	Basic static load rating
					d	Fw (F)	D	C		
NA 49	g	RNA 49	g	IR					Cr N	Cor N
NA 495	7.3	RNA 495	5.9	—	5	7	13	10	2 960	2 690
NA 496	9.1	RNA 496	7.3	IR6810	6	8	15	10	3 900	3 400
NA 497	11.2	RNA 497	9.3	IR7910	7	9	17	10	4 500	3 600
NA 498	15	RNA 498	12.6	IR81011	8	10	19	11	6 200	5 000
NA 499	16.7	RNA 499	13.6	IR91211	9	12	20	11	6 600	6 300
NA 4900	24	RNA 4900	16.5	IR101413	10	14	22	13	9 200	10 100
NA 4901	26.5	RNA 4901	18.1	IR121613	12	16	24	13	9 700	11 100
NA 4902	35	RNA 4902	21.5	IR152013	15	20	28	13	10 900	13 800
NA 4903	39	RNA 4903	23.5	IR172213	17	22	30	13	11 800	15 600
NA 4904	78.5	RNA 4904	55.5	IR202517	20	25	37	17	21 000	25 000
NA 49/22	87	RNA 49/22	56.5	IR222817	22	28	39	17	21 400	28 800
NA 4905	92.5	RNA 4905	64	IR253017	25	30	42	17	23 700	30 700
NA 49/28	101	RNA 49/28	76.5	IR283217	28	32	45	17	24 500	32 700
NA 4906	106	RNA 4906	72.5	IR303517	30	35	47	17	25 200	34 700
NA 49/32	165	RNA 49/32	96	IR324020	32	40	52	20	31 300	47 900
NA 4907	178	RNA 4907	113	IR354220	35	42	55	20	32 000	50 200
NA 4908	245	RNA 4908	152	IR404822	40	48	62	22	41 600	67 400
NA 4909	285	RNA 4909	197	IR455222	45	52	68	22	43 500	73 400
NA 4910	295	RNA 4910	179	IR505822	50	58	72	22	46 200	82 100
NA 4911	410	RNA 4911	265	IR556325	55	63	80	25	57 600	97 300
NA 4912	440	RNA 4912	285	IR606825	60	68	85	25	60 100	104 900
NA 4913	470	RNA 4913	325	IR657225	65	72	90	25	62 800	113 800
NA 4914	765	RNA 4914	495	IR708030	70	80	100	30	83 200	157 900
NA 4915	810	RNA 4915	525	IR758530	75	85	105	30	86 200	169 700
NA 4916	855	RNA 4916	550	IR809030	80	90	110	30	87 400	174 600
NA 4917	1 280	RNA 4917	705	IR8510035	85	100	120	35	109 800	244 200
NA 4918	1 350	RNA 4918	740	IR9010535	90	105	125	35	112 800	257 900
NA 4919	1 420	RNA 4919	770	IR9511035	95	110	130	35	116 700	270 700
NA 4920	1 960	RNA 4920	1 190	IR10011540	100	115	140	40	145 000	329 000
NA 4922	2 120	RNA 4922	1 280	IR11012540	110	125	150	40	152 000	357 000
NA 4924	2 960	RNA 4924	1 930	IR12013545	120	135	165	45	187 000	435 000
NA 4926	4 030	RNA 4926	2 360	IR13015050	130	150	180	50	216 000	540 000
NA 4928	4 290	RNA 4928	2 500	IR14016050	140	160	190	50	224 000	580 000



INTERCHANGE

INTERCHANGE TABLE

IKO		INA		NTN		TORRINGTON(KOYO)	
WITH INNER RING	WITHOUT INNER RING	WITH INNER RING	WITHOUT INNER RING	WITH INNER RING	WITHOUT INNER RING	WITH INNER RING	WITHOUT INNER RING
NA 49	RNA 49	NA 49	RNA 49	NA 49	RNA 49	NA 49	RNA 49
—	—	—	—	—	—	—	—
NA496	RNA496	NA496	—	NA496	RNA496	—	—
NA497	RNA497	NA497	—	NA497	RNA497	—	—
NA498	RNA498	NA498	—	NA498	RNA498	—	—
NA499	RNA499	NA499	—	NA499	RNA499	—	—
NA4900	RNA4900	NA4900	RNA4900	NA4900R	RNA4900R	NA4900	RNA4900
NA4901	RNA4901	NA4901	RNA4901	NA4901R	RNA4901R	NA4901	RNA4901
NA4902	RNA4902	NA4902	RNA4902	NA4902R	RNA4902R	NA4902	RNA4902
NA4903	RNA4903	NA4903	RNA4903	NA4903R	RNA4903R	NA4903	RNA4903
NA4904	RNA4904	NA4904	RNA4904	NA4904R	RNA4904R	NA4904	RNA4904
NA49/22	RNA49/22	NA49/22	RNA49/22	NA49/22R	RNA49/22R	NA49/22	RNA49/22
NA4905	RNA4905	NA4905	RNA4905	NA4905R	RNA4905R	NA4905	RNA4905
NA49/28	RNA49/28	NA49/28	RNA49/28	NA49/28R	RNA49/28R	—	—
NA4906	RNA4906	NA4906	RNA4906	NA4906R	RNA4906R	NA4906	RNA4906
NA49/32	RNA49/32	NA49/32	RNA49/32	NA49/32R	RNA49/32R	NA49/32	RNA49/32
NA4907	RNA4907	NA4907	RNA4907	NA4907R	RNA4907R	NA4907	RNA4907
NA4908	RNA4908	NA4908	RNA4908	NA4908R	RNA4908R	NA4908	RNA4908
NA4909	RNA4909	NA4909	RNA4909	NA4909R	RNA4909R	NA4909	RNA4909
NA4910	RNA4910	NA4910	RNA4910	NA4910R	RNA4910R	NA4910	RNA4910
NA4911	RNA4911	NA4911	RNA4911	NA4911R	RNA4911R	NA4911	RNA4911
NA4912	RNA4912	NA4912	RNA4912	NA4912R	RNA4912R	NA4912	RNA4912
NA4913	RNA4913	NA4913	RNA4913	NA4913R	RNA4913R	NA4913	RNA4913
NA4914	RNA4914	NA4914	RNA4914	NA4914R	RNA4914R	NA4914	RNA4914
NA4915	RNA4915	NA4915	RNA4915	NA4915R	RNA4915R	NA4915	RNA4915
NA4916	RNA4916	NA4916	RNA4916	NA4916R	RNA4916R	NA4916	RNA4916
NA4917	RNA4917	NA4917	RNA4917	NA4917R	RNA4917R	NA4917	RNA4917
NA4918	RNA4918	NA4918	RNA4918	NA4918R	RNA4918R	NA4918	RNA4918
NA4919	RNA4919	NA4919	RNA4919	NA4919R	RNA4919R	NA4919	RNA4919
NA4920	RNA4920	NA4920	RNA4920	NA4920	RNA4920	NA4920	RNA4920
NA4922	RNA4922	NA4922	RNA4922	NA4922	RNA4922	NA4922	RNA4922
NA4924	RNA4924	NA4924	RNA4924	NA4924	RNA4924	NA4924	RNA4924
NA4926	RNA4926	NA4926	RNA4926	NA4926	RNA4926	NA4926	RNA4926
NA4928	RNA4928	NA4928	RNA4928	NA4928	RNA4928	NA4928	RNA4928



INTERCHANGE

MACHINED RING NEEDLE ROLLER BEARINGS WITH INNER RING WITHOUT INNER RING

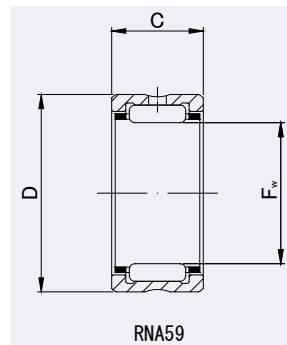
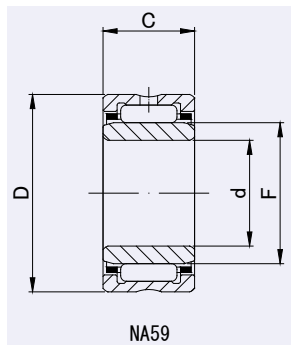

NA59, RNA59

DIMENSION TABLE

JNS NUMBER WITH INNER RING	Mass (Approx.)	JNS NUMBER WITHOUT INNER RING	Mass (Approx.)	JNS NUMBER Assembled INNER RING	Dimensions(mm)				Basic dynamic load rating	Basic static load rating
					d	Fw (F)	D	C		
NA 59	g	RNA 59	g	IR					Cr N	Cor N
NA 5902	52	RNA 5902	33	IR152018	15	20	28	18	15 700	22 100
NA 5903	56	RNA 5903	35	IR172218	17	22	30	18	16 900	24 900
NA 5904	115	RNA 5904	84	IR202523	20	25	37	23	29 400	38 600
NA 59/22	134	RNA 59/22	92	IR222823	22	28	39	23	29 800	44 400
NA 5905	139	RNA 5905	101	IR253023	25	30	42	23	33 200	47 500
NA 59/28	142	RNA 59/28	108	IR283223	28	32	45	23	34 300	50 500
NA 5906	152	RNA 5906	108	IR303523	30	35	47	23	35 200	53 700
NA 59/32	241	RNA 59/32	149	IR324027	32	40	52	27	41 900	69 900
NA 5907	256	RNA 5907	176	IR354227	35	42	55	27	42 900	73 200
NA 5908	348	RNA 5908	225	IR404830	40	48	62	30	58 000	103 000
NA 5909	396	RNA 5909	232	IR455230	45	52	68	30	60 700	112 000
NA 5910	498	RNA 5910	289	IR505830	50	58	72	30	64 400	126 000
NA 5911	559	RNA 5911	367	IR556334	55	63	80	34	82 600	154 000
NA 5912	614	RNA 5912	408	IR606834	60	68	85	34	86 100	167 000
NA 5913	655	RNA 5913	462	IR657234	65	72	90	34	89 900	180 000
NA 5914	1 060	RNA 5914	706	IR708040	70	80	100	40	112 000	232 000
NA 5915	1 130	RNA 5915	745	IR758540	75	85	105	40	116 000	249 000
NA 5916	1 150	RNA 5916	787	IR809040	80	90	110	40	117 000	257 000
NA 5917	1 760	RNA 5917	1 000	IR8510046	85	100	120	46	144 000	346 000
NA 5918	1 840	RNA 5918	1 040	IR9010546	90	105	125	46	148 000	365 000
NA 5919	1 980	RNA 5919	1 130	IR9511046	95	110	130	46	152 000	384 000



INTERCHANGE

INTERCHANGE TABLE

IKO		INA		NTN		TORRINGTON(KOYO)	
WITH INNER RING	WITHOUT INNER RING	WITH INNER RING	WITHOUT INNER RING	WITH INNER RING	WITHOUT INNER RING	WITH INNER RING	WITHOUT INNER RING
—	—	—	—	NA 59	RNA 59	—	—
—	—	—	—	NA5902	RNA5902	—	—
—	—	—	—	NA5903	RNA5903	—	—
—	—	—	—	NA5904	RNA5904	—	—
—	—	—	—	NA59/22	RNA59/22	—	—
—	—	—	—	NA5905	RNA5905	—	—
—	—	—	—	NA59/28	RNA59/28	—	—
—	—	—	—	NA5906	RNA5906	—	—
—	—	—	—	NA59/32	RNA59/32	—	—
—	—	—	—	NA5907	RNA5907	—	—
—	—	—	—	NA5908	RNA5908	—	—
—	—	—	—	NA5909	RNA5909	—	—
—	—	—	—	NA5910	RNA5910	—	—
—	—	—	—	NA5911	RNA5911	—	—
—	—	—	—	NA5912	RNA5912	—	—
—	—	—	—	NA5913	RNA5913	—	—
—	—	—	—	NA5914	RNA5914	—	—
—	—	—	—	NA5915	RNA5915	—	—
—	—	—	—	NA5916	RNA5916	—	—
—	—	—	—	NA5917	RNA5917	—	—
—	—	—	—	NA5918	RNA5918	—	—
—	—	—	—	NA5919	RNA5919	—	—



MACHINED RING NEEDLE ROLLER BEARINGS WITH INNER RING WITHOUT INNER RING

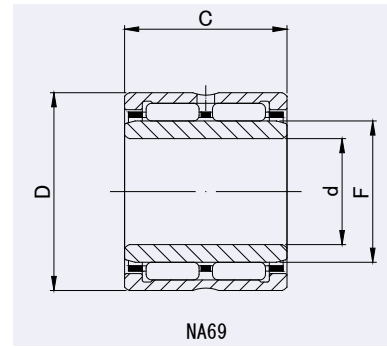
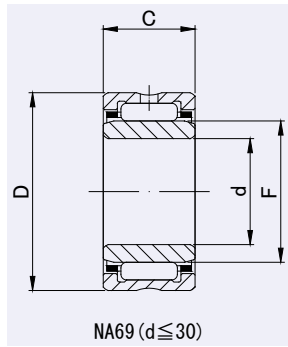

NA69, RNA69

DIMENSION TABLE

JNS NUMBER WITH INNER RING	Mass (Approx.)	JNS NUMBER WITHOUT INNER RING	Mass (Approx.)	JNS NUMBER Assembled INNER RING	Dimensions(mm)				Basic dynamic load rating	Basic static load rating
					d	Fw (F)	D	C		
NA 69	g	RNA 69	g	IR					Cr N	Cor N
NA 6901	44.5	RNA 6901	30	IR121622	12	16	24	22	17 100	23 000
NA 6902	61	RNA 6902	37	IR152023	15	20	28	23	19 300	28 700
NA 6903	67	RNA 6903	40.5	IR172223	17	22	30	23	20 800	32 500
NA 6904	136	RNA 6904	95.5	IR202530	20	25	37	30	35 400	48 800
NA 69/22	152	RNA 69/22	97.5	IR222830	22	28	39	30	36 300	56 900
NA 6905	160	RNA 6905	111	IR253030	25	30	42	30	42 100	64 200
NA 69/28	176	RNA 69/28	133	IR283230	28	32	45	30	41 800	64 700
NA 6906	184	RNA 6906	125	IR303530	30	35	47	30	43 100	69 000
NA 69/32	295	RNA 69/32	172	IR324036	32	40	52	36	53 500	95 700
NA 6907	320	RNA 6907	200	IR354236	35	42	55	36	54 800	100 000
NA 6908	440	RNA 6908	275	IR404840	40	48	62	40	71 300	134 400
NA 6909	520	RNA 6909	355	IR455240	45	52	68	40	74 600	147 100
NA 6910	530	RNA 6910	320	IR505840	50	58	72	40	79 100	163 800
NA 6911	730	RNA 6911	475	IR556345	55	63	80	45	99 000	194 200
NA 6912	785	RNA 6912	510	IR606845	60	68	85	45	103 000	210 800
NA 6913	840	RNA 6913	585	IR657245	65	72	90	45	107 900	226 500
NA 6914	1 400	RNA 6914	910	IR708054	70	80	100	54	133 400	310 900
NA 6915	1 480	RNA 6915	960	IR758554	75	85	105	54	138 300	330 500
NA 6916	1 560	RNA 6916	1 010	IR809054	80	90	110	54	143 200	350 100
NA 6917	2 340	RNA 6917	1 300	IR8510063	85	100	120	63	172 600	466 800
NA 6918	2 460	RNA 6918	1 360	IR9010563	90	105	125	63	177 500	490 300
NA 6919	2 580	RNA 6919	1 420	IR9511063	95	110	130	63	182 400	514 800



INTERCHANGE

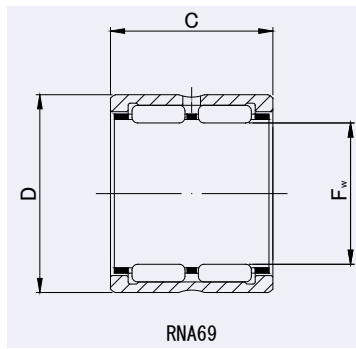
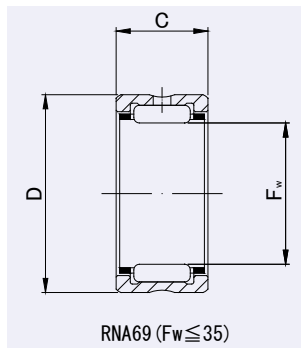

INTERCHANGE TABLE

IKO		INA		NTN		TORRINGTON(KOYO)	
WITH INNER RING	WITHOUT INNER RING	WITH INNER RING	WITHOUT INNER RING	WITH INNER RING	WITHOUT INNER RING	WITH INNER RING	WITHOUT INNER RING
NA 69	RNA 69	NA 69	RNA 69	NA 69	RNA 69	NA 69	RNA 69
NA6901	RNA6901	NA6901	RNA6901	NA6901R	RNA6901R	NA6901	RNA6901
NA6902	RNA6902	NA6902	RNA6902	NA6902R	RNA6902R	NA6902	RNA6902
NA6903	RNA6903	NA6903	RNA6903	NA6903R	RNA6903R	NA6903	RNA6903
NA6904	RNA6904	NA6904	RNA6904	NA6904R	RNA6904R	NA6904	RNA6904
NA69/22	RNA69/22	NA69/22	RNA69/22	NA69/22R	RNA69/22R	NA69/22	RNA69/22
NA6905	RNA6905	NA6905	RNA6905	NA6905R	RNA6905R	NA6905	RNA6905
NA69/28	RNA69/28	NA69/28	RNA69/28	NA69/28R	RNA69/28R	NA69/28	RNA69/28
NA6906	RNA6906	NA6906	RNA6906	NA6906R	RNA6906R	NA6906	RNA6906
NA69/32	RNA69/32	NA69/32	RNA69/32	NA69/32R	RNA69/32R	NA69/32	RNA69/32
NA6907	RNA6907	NA6907	RNA6907	NA6907R	RNA6907R	NA6907	RNA6907
NA6908	RNA6908	NA6908	RNA6908	NA6908R	RNA6908R	NA6908	RNA6908
NA6909	RNA6909	NA6909	RNA6909	NA6909R	RNA6909R	NA6909	RNA6909
NA6910	RNA6910	NA6910	RNA6910	NA6910R	RNA6910R	NA6910	RNA6910
NA6911	RNA6911	NA6911	RNA6911	NA6911R	RNA6911R	NA6911	RNA6911
NA6912	RNA6912	NA6912	RNA6912	NA6912R	RNA6912R	NA6912	RNA6912
NA6913	RNA6913	NA6913	RNA6913	NA6913R	RNA6913R	NA6913	RNA6913
NA6914	RNA6914	NA6914	RNA6914	NA6914R	RNA6914R	NA6914	RNA6914
NA6915	RNA6915	NA6915	RNA6915	NA6915R	RNA6915R	NA6915	RNA6915
NA6916	RNA6916	NA6916	RNA6916	NA6916R	RNA6916R	NA6916	RNA6916
NA6917	RNA6917	NA6917	RNA6917	NA6917R	RNA6917R	NA6917	RNA6917
NA6918	RNA6918	NA6918	RNA6918	NA6918R	RNA6918R	NA6918	RNA6918
NA6919	RNA6919	NA6919	RNA6919	NA6919R	RNA6919R	NA6919	RNA6919



INTERCHANGE

MACHINED RING NEEDLE ROLLER BEARINGS WITH INNER RING WITHOUT INNER RING

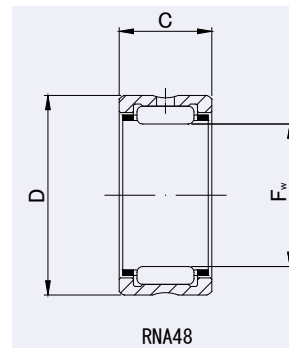
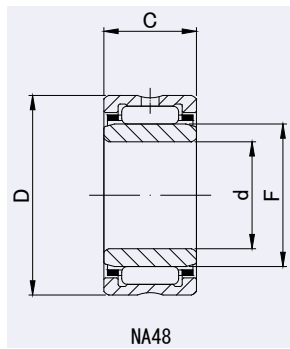

NA48, RNA48

DIMENSION TABLE

JNS NUMBER WITH INNER RING	Mass (Approx.)	JNS NUMBER WITHOUT INNER RING	Mass (Approx.)	JNS NUMBER Assembled INNER RING	Dimensions(mm)				Basic dynamic load rating	Basic static load rating
					d	Fw (F)	D	C		
NA 48	g	RNA 48	g	IR					Cr N	Cor N
NA 4822	1 200	RNA4822	790	IR11012030	110	120	140	30	93 000	239 000
NA 4824	1 300	RNA4824	850	IR12013030	120	130	150	30	97 000	259 000
NA 4826	1 960	RNA4826	1 100	IR13014535	130	145	165	35	117 000	340 000
NA 4828	2 100	RNA4828	1 170	IR14015535	140	155	175	35	121 000	363 000
NA 4830	2 880	RNA4830	1 750	IR15016540	150	165	190	40	168 000	446 000
NA 4832	3 050	RNA4832	1 850	IR16017540	160	175	200	40	173 000	474 000



INTERCHANGE

INTERCHANGE TABLE

IKO		INA		NTN		TORRINGTON(KOYO)	
WITH INNER RING	WITHOUT INNER RING	WITH INNER RING	WITHOUT INNER RING	WITH INNER RING	WITHOUT INNER RING	WITH INNER RING	WITHOUT INNER RING
NA 48	RNA 48	NA 48	RNA 48	NA 48	RNA 48	NA 48	RNA 48
NA4822	RNA4822	NA4822	RNA4822	NA4822	RNA4822	NA4822	RNA4822
NA4824	RNA4824	NA4824	RNA4824	NA4824	RNA4824	NA4824	RNA4824
NA4826	RNA4826	NA4826	RNA4826	NA4826	RNA4826	NA4826	RNA4826
NA4828	RNA4828	NA4828	RNA4828	NA4828	RNA4828	NA4828	RNA4828
NA4830	RNA4830	NA4830	RNA4830	NA4830	RNA4830	NA4830	RNA4830
NA4832	RNA4832	NA4832	RNA4832	NA4832	RNA4832	NA4832	RNA4832



MACHINED RING NEEDLE ROLLER BEARINGS WITH INNER RING WITHOUT INNER RING

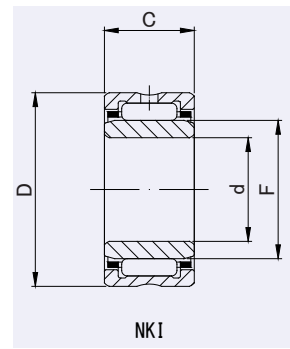
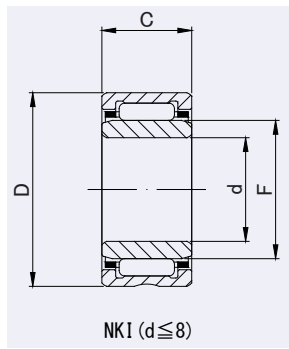

NK, NKI

DIMENSION TABLE

JNS NUMBER WITH INNER RING	Mass (Approx.)	JNS NUMBER WITHOUT INNER RING	Mass (Approx.)	JNS NUMBER Assembled INNER RING	Dimensions(mm)				Basic dynamic load rating	Basic static load rating
					d	Fw (F)	D	C		
NKI	g	NK	g	IR	d	Fw (F)	D	C	Cr N	Cor N
—	—	NK5/10	3.4	—	—	5	10	10	2 420	1 950
—	—	NK5/12	4.2	—	—	5	10	12	3 080	2 660
—	—	NK6/10	5.3	—	—	6	12	10	2 700	2 320
—	—	NK6/12	6.4	—	—	6	12	12	3 440	3 170
—	—	NK7/10	6.9	—	—	7	14	10	3 600	2 960
—	—	NK7/12	8.3	—	—	7	14	12	4 610	4 050
NKI 5/12	11.9	NK8/12	9	IR5812	5	8	15	12	5 100	4 700
NKI 5/16	16.7	NK8/16	13	IR5816	5	8	15	16	7 100	7 300
NKI 6/12	13	NK9/12	10	IR6912	6	9	16	12	5 500	5 300
NKI 6/16	17.5	NK9/16	13.2	IR6916	6	9	16	16	7 600	8 200
NKI 7/12	14.3	NK10/12	10.7	IR71012	7	10	17	12	5 900	6 000
NKI 7/16	19.2	NK10/16	14.3	IR71016	7	10	17	16	8 200	9 200
NKI 9/12	16.7	NK12/12	12.2	IR91212	9	12	19	12	6 600	7 300
NKI 9/16	22.5	NK12/16	16.3	IR91216	9	12	19	16	9 200	11 200
NKI 10/16	30	NK14/16	21	IR101416	10	14	22	16	11 800	13 700
NKI 10/20	38	NK14/20	26.5	IR101420	10	14	22	20	14 800	18 500
—	—	NK15/16	22.5	—	—	15	23	16	12 400	14 900
—	—	NK15/20	28	—	—	15	23	20	15 600	20 200
NKI 12/16	33.5	NK16/16	23	IR121616	12	16	24	16	12 300	15 100
NKI 12/20	42.5	NK16/20	29	IR121620	12	16	24	20	15 600	20 400
—	—	NK17/16	25	—	—	17	25	16	12 800	16 300
—	—	NK17/20	31	—	—	17	25	20	16 300	22 100
—	—	NK18/16	26	—	—	18	26	16	13 400	17 500
—	—	NK18/20	32	—	—	18	26	20	17 000	23 600
NKI 15/16	39.5	NK19/16	27	IR151916	15	19	27	16	14 000	18 700
NKI 15/20	50	NK19/20	34	IR151920	15	19	27	20	17 700	25 300
—	—	NK20/16	28	—	—	20	28	16	13 900	18 700
—	—	NK20/20	36	—	—	20	28	20	17 600	25 400
NKI 17/16	43.5	NK21/16	29	IR172116	17	21	29	16	14 400	20 000
NKI 17/20	54	NK21/20	36	IR172120	17	21	29	20	18 200	27 100
—	—	NK22/16	30	—	—	22	30	16	14 900	21 200
—	—	NK22/20	38	—	—	22	30	20	18 900	28 700
NKI 20/16	48.5	NK24/16	32	IR202416	20	24	32	16	15 300	22 600
NKI 20/20	61	NK24/20	41	IR202420	20	24	32	20	19 400	30 500

NK type of 10mm or less inscribed circle diameter (Fw) is without oil hole.
NKI type of 8mm or less inscribed circle diameter (d) is without oil hole.



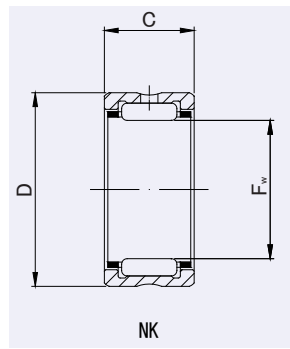
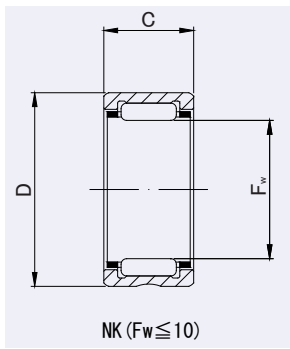

INTERCHANGE TABLE

IKO		INA		NTN		TORRINGTON(KOYO)	
WITH INNER RING	WITHOUT INNER RING	WITH INNER RING	WITHOUT INNER RING	WITH INNER RING	WITHOUT INNER RING	WITH INNER RING	WITHOUT INNER RING
TAFI	TAF	NKI	NK	NK+IR	NK	NKJ	NK
—	TAF51010	—	NK5/10 TN	—	NK5/10 T2	—	NK5/10 TN
—	TAF51012	—	NK5/12 TN	—	NK5/12 T2	—	NK5/12 TN
—	—	—	NK6/10 TN	—	NK6/10 T2	—	NK6/10
—	TAF61212	—	NK6/12 TN	—	NK6/12 T2	—	NK6/12 TN
—	TAF71410	—	NK7/10 TN	—	NK7/10 T2	—	NK7/10 TN
—	TAF71412	—	NK7/12 TN	—	NK7/12 T2	—	NK7/12 TN
TAFI 51512	TAF81512	NKI 5/12 TN	NK8/12 TN	NK8/12 T2 + IR5812	NK8/12 T2	NKJ 5/12	NK8/12
TAFI 51516	TAF81516	NKI 5/16 TN	NK8/16 TN	NK8/16 T2 + IR5816	NK8/16 T2	NKJ 5/16	NK8/16
TAFI 61612	TAF91612	NKI 6/12 TN	NK9/12 TN	NK9/12 T2 + IR6912	NK9/12 T2	NKJ 6/12	NK9/12
TAFI 61616	TAF91616	NKI 6/16 TN	NK9/16 TN	NK9/16 T2 + IR6916	NK9/16 T2	NKJ 6/16	NK9/16
TAFI 71712	TAF101712	NKI 7/12 TN	NK10/12 TN	NK10/12 T2 + IR71012	NK10/12 T2	NKJ 7/12	NK10/12
TAFI 71716	TAF101716	NKI 7/16 TN	NK10/16 TN	NK10/16 + IR71016	NK10/16	NKJ 7/16 TN	NK10/16 TN
TAFI 91912	TAF121912	NKI 9/12	NK12/12	NK12/12 + IR91212	NK12/12	NKJ 9/12	NK12/12
TAFI 91916	TAF121916	NKI 9/16	NK12/16	NK12/16 + IR91216	NK12/16	NKJ 9/16	NK12/16
TAFI 102216	TAF142216	NKI 10/16	NK14/16	NK14/16R + IR101416	NK14/16R	NKJ 10/16	NK14/16
TAFI 102220	TAF142220	NKI 10/20	NK14/20	NK14/20R + IR101420	NK14/20R	NKJ 10/20	NK14/20
—	TAF152316	—	NK15/16	—	NK15/16R	—	NK15/16
—	TAF152320	—	NK15/20	—	NK15/20R	—	NK15/20
TAFI 122416	TAF162416	NKI 12/16	NK16/16	NK16/16R + IR121616	NK16/16R	NKJ 12/16	NK16/16
TAFI 122420	TAF162420	NKI 12/20	NK16/20	NK16/20R + IR121620	NK16/20R	NKJ 12/20	NK16/20
—	TAF172516	—	NK17/16	—	NK17/16R	—	NK17/16
—	TAF172520	—	NK17/20	—	NK17/20R	—	NK17/20
—	TAF182616	—	NK18/16	—	NK18/16R	—	NK18/16
—	TAF182620	—	NK18/20	—	NK18/20R	—	NK18/20
TAFI 152716	TAF192716	NKI 15/16	NK19/16	NK19/16R + IR151916	NK19/16R	NKJ 15/16	NK19/16
TAFI 152720	TAF192720	NKI 15/20	NK19/20	NK19/20R + IR151920	NK19/20R	NKJ 15/20	NK19/20
—	TAF202816	—	NK20/16	—	NK20/16R	—	NK20/16
—	TAF202820	—	NK20/20	—	NK20/20R	—	NK20/20
TAFI 172916	TAF212916	NKI 17/16	NK21/16	NK21/16R + IR172116	NK21/16R	NKJ 17/16	NK21/16
TAFI 172920	TAF212920	NKI 17/20	NK21/20	NK21/20R + IR172120	NK21/20R	NKJ 17/20	NK21/20
—	TAF223016	—	NK22/16	—	NK22/16R	—	NK22/16
—	TAF223020	—	NK22/20	—	NK22/20R	—	NK22/20
TAFI 203216	TAF243216	NKI 20/16	NK24/16	NK24/16R + IR202416	NK24/16R	NKJ 20/16	NK24/16
TAFI 203220	TAF243220	NKI 20/20	NK24/20	NK24/20R + IR202420	NK24/20R	NKJ 20/20	NK24/20



INTERCHANGE

MACHINED RING NEEDLE ROLLER BEARINGS WITH INNER RING WITHOUT INNER RING

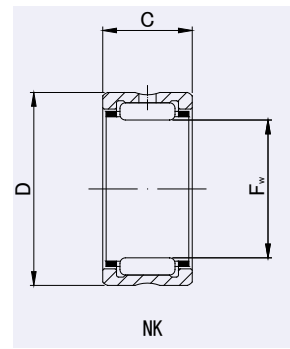
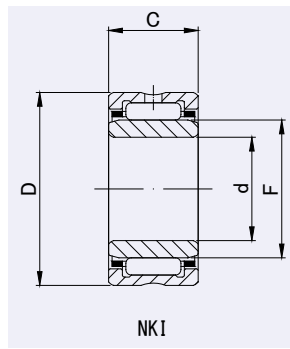

NK, NKI

DIMENSION TABLE

JNS NUMBER WITH INNER RING	Mass (Approx.)	JNS NUMBER WITHOUT INNER RING	Mass (Approx.)	JNS NUMBER Assembled INNER RING	Dimensions(mm)				Basic dynamic load rating	Basic static load rating
					d	Fw (F)	D	C		
NKI	g	NK	g	IR					Cr N	Cor N
—	—	NK25/16	34	—	—	25	33	16	15 800	23 700
—	—	NK25/20	42	—	—	25	33	20	20 000	32 200
NKI 22/16	52	NK26/16	35	IR222616	22	26	34	16	16 300	24 900
NKI 22/20	67.5	NK26/20	44	IR222620	22	26	34	20	20 600	33 700
—	—	NK28/20	52	—	—	28	37	20	21 700	37 100
—	—	NK28/30	84	—	—	28	37	30	31 100	58 900
NKI 25/20	82	NK29/20	57	IR252920	25	29	38	20	21 600	37 200
NKI 25/30	123	NK29/30	85	IR252930	25	29	38	30	30 900	59 000
—	—	NK30/20	65	—	—	30	40	20	25 100	40 100
—	—	NK30/30	98	—	—	30	40	30	36 000	63 800
NKI 28/20	96.5	NK32/20	68	IR283220	28	32	42	20	25 700	42 200
NKI 28/30	145	NK32/30	102	IR283230	28	32	42	30	36 900	67 100
NKI 30/20	112	NK35/20	74	IR303520	30	35	45	20	27 000	46 200
NKI 30/30	171	NK35/30	112	IR303530	30	35	45	30	38 600	73 500
NKI 32/20	121	NK37/20	78	IR323720	32	37	47	20	28 200	50 100
NKI 32/30	180	NK37/30	117	IR323730	32	37	47	30	40 500	79 800
—	—	NK38/20	79	—	—	38	48	20	28 100	50 200
—	—	NK38/30	119	—	—	38	48	30	40 300	80 000
NKI 35/20	129	NK40/20	83	IR354020	35	40	50	20	29 400	54 100
NKI 35/30	192	NK40/30	125	IR354030	35	40	50	30	42 300	86 100
—	—	NK42/20	87	—	—	42	52	20	29 900	56 200
—	—	NK42/30	130	—	—	42	52	30	43 000	89 500
NKI 38/20	136	NK43/20	89	IR384320	38	43	53	20	30 500	58 100
NKI 38/30	205	NK43/30	133	IR384330	38	43	53	30	43 700	92 500
NKI 40/20	143	NK45/20	92	IR404520	40	45	55	20	31 100	60 100
NKI 40/30	215	NK45/30	138	IR404530	40	45	55	30	44 500	95 700
NKI 42/20	149	NK47/20	95	IR424720	42	47	57	20	31 500	62 300
NKI 42/30	225	NK47/30	144	IR424730	42	47	57	30	45 200	99 000
NKI 45/25	230	NK50/25	159	IR455025	45	50	62	25	43 000	85 200
NKI 45/35	320	NK50/35	225	IR455035	45	50	62	35	58 100	125 500
NKI 50/25	270	NK55/25	193	IR505525	50	55	68	25	45 400	94 100
NKI 50/35	365	NK55/35	255	IR505535	50	55	68	35	61 300	138 300
NKI 55/25	275	NK60/25	187	IR556025	55	60	72	25	47 500	103 000
NKI 55/35	380	NK60/35	260	IR556035	55	60	72	35	64 100	151 000

NK type of 10mm or less inscribed circle diameter (Fw) is without oil hole.
NKI type of 8mm or less inscribed circle diameter (d) is without oil hole.



INTERCHANGE

INTERCHANGE TABLE

IKO		INA		NTN		TORRINGTON(KOYO)	
WITH INNER RING	WITHOUT INNER RING	WITH INNER RING	WITHOUT INNER RING	WITH INNER RING	WITHOUT INNER RING	WITH INNER RING	WITHOUT INNER RING
TAFI	TAF	NKI	NK	NK+IR	NK	NKJ	NK
—	TAF253316	—	NK25/16	—	NK25/16R	—	NK25/16
—	TAF253320	—	NK25/20	—	NK25/20R	—	NK25/20
TAFI 223416	TAF263416	NKI 22/16	NK26/16	NK26/16R + IR222616	NK26/16R	NKJ 22/16	NK26/16
TAFI 223420	TAF263420	NKI 22/20	NK26/20	NK26/20R + IR222620	NK26/20R	NKJ 22/20	NK26/20
—	TAF283720	—	NK28/20	—	NK28/20R	—	NK28/20
—	TAF283730	—	NK28/30	—	NK28/30R	—	NK28/30
TAFI 253820	TAF293820	NKI 25/20	NK29/20	NK29/20R + IR252920	NK29/20R	NKJ 25/20	NK29/20
TAFI 253830	TAF293830	NKI 25/30	NK29/30	NK29/30R + IR252930	NK29/30R	NKJ 25/30	NK29/30
—	TAF304020	—	NK30/20	—	NK30/20R	—	NK30/20
—	TAF304030	—	NK30/30	—	NK30/30R	—	NK30/30
TAFI 284220	TAF324220	NKI 28/20	NK32/20	NK32/20R + IR283220	NK32/20R	NKJ 28/20	NK32/20
TAFI 284230	TAF324230	NKI 28/30	NK32/30	NK32/30R + IR283230	NK32/30R	NKJ 28/30	NK32/30
TAFI 304520	TAF354520	NKI 30/20	NK35/20	NK35/20R + IR303520	NK35/20R	NKJ 30/20	NK35/20
TAFI 304530	TAF354530	NKI 30/30	NK35/30	NK35/30R + IR303530	NK35/30R	NKJ 30/30	NK35/30
TAFI 324720	TAF374720	NKI 32/20	NK37/20	NK37/20R + IR323720	NK37/20R	NKJ 32/20	NK37/20
TAFI 324730	TAF374730	NKI 32/30	NK37/30	NK37/30R + IR323730	NK37/30R	NKJ 32/30	NK37/30
—	TAF384820	—	NK38/20	—	NK38/20R	—	NK38/20
—	TAF384830	—	NK38/30	—	NK38/30R	—	NK38/30
TAFI 355020	TAF405020	NKI 35/20	NK40/20	NK40/20R + IR354020	NK40/20R	NKJ 35/20	NK40/20
TAFI 355030	TAF405030	NKI 35/30	NK40/30	NK40/30R + IR354030	NK40/30R	NKJ 35/30	NK40/30
—	TAF425220	—	NK42/20	—	NK42/20R	—	NK42/20
—	TAF425230	—	NK42/30	—	NK42/30R	—	NK42/30
TAFI 385320	TAF435320	NKI 38/20	NK43/20	NK43/20R + IR384320	NK43/20R	NKJ 38/20	NK43/20
TAFI 385330	TAF435330	NKI 38/30	NK43/30	NK43/30R + IR384330	NK43/30R	NKJ 38/30	NK43/30
TAFI 405520	TAF455520	NKI 40/20	NK45/20	NK45/20R + IR404520	NK45/20R	NKJ 40/20	NK45/20
TAFI 405530	TAF455530	NKI 40/30	NK45/30	NK45/30R + IR404530	NK45/30R	NKJ 40/30	NK45/30
TAFI 425720	TAF475720	NKI 42/20	NK47/20	NK47/20R + IR424720	NK47/20R	NKJ 42/20	NK47/20
TAFI 425730	TAF475730	NKI 42/30	NK47/30	NK47/30R + IR424730	NK47/30R	NKJ 42/30	NK47/30
TAFI 456225	TAF506225	NKI 45/25	NK50/25	NK50/25R + IR455025	NK50/25R	NKJ 45/25	NK50/25
TAFI 456235	TAF506235	NKI 45/35	NK50/35	NK50/35R + IR455035	NK50/35R	NKJ 45/35	NK50/35
TAFI 506825	TAF556825	NKI 50/25	NK55/25	NK55/25R + IR505525	NK55/25R	NKJ 50/25	NK55/25
TAFI 506835	TAF556835	NKI 50/35	NK55/35	NK55/35R + IR505535	NK55/35R	NKJ 50/35	NK55/35
TAFI 557225	TAF607225	NKI 55/25	NK60/25	NK60/25R + IR556025	NK60/25R	NKJ 55/25	NK60/25
TAFI 557235	TAF607235	NKI 55/35	NK60/35	NK60/35R + IR556035	NK60/35R	NKJ 55/35	NK60/35



INTERCHANGE

MACHINED RING NEEDLE ROLLER BEARINGS WITH INNER RING WITHOUT INNER RING

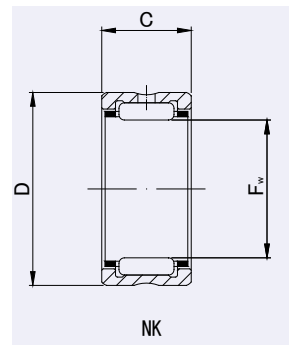
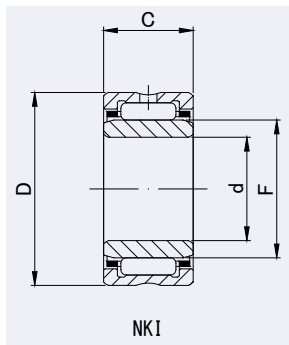

NK, NKI

DIMENSION TABLE

JNS NUMBER WITH INNER RING	Mass (Approx.)	JNS NUMBER WITHOUT INNER RING	Mass (Approx.)	JNS NUMBER Assembled INNER RING	Dimensions(mm)				Basic dynamic load rating	Basic static load rating
					d	Fw (F)	D	C		
NKI	g	NK	g	IR					Cr N	Cor N
—	—	NK65/25	225	—	—	65	78	25	49 600	111 800
—	—	NK65/35	315	—	—	65	78	35	67 000	164 800
NKI 60/25	395	NK68/25	250	IR606825	60	68	82	25	54 800	116 700
NKI 60/35	560	NK68/35	350	IR606835	60	68	82	35	72 100	165 700
—	—	NK70/25	280	—	—	70	85	25	55 500	120 600
—	—	NK70/35	395	—	—	70	85	35	73 000	170 600
—	—	NK73/25	335	—	—	73	90	25	61 100	126 500
NKI 65/35	710	NK73/35	475	IR657335	65	73	90	35	80 400	180 400
—	—	NK75/25	345	—	—	75	92	25	62 200	130 400
—	—	NK75/35	485	—	—	75	92	35	82 700	186 300
NKI 70/25	540	NK80/25	315	IR708025	70	80	95	25	59 400	137 300
NKI 70/35	755	NK80/35	445	IR708035	70	80	95	35	78 100	194 200
NKI 75/25	675	NK85/25	435	IR758525	75	85	105	25	76 400	145 100
NKI 75/35	945	NK85/35	610	IR758535	75	85	105	35	102 000	209 900
NKI 80/25	710	NK90/25	456	IR809025	80	90	110	25	77 400	150 000
NKI 80/35	995	NK90/35	640	IR809035	80	90	110	35	103 000	216 700
NKI 85/26	775	NK95/26	495	IR859526	85	95	115	26	79 700	158 900
NKI 85/36	1 080	NK95/36	690	IR859536	85	95	115	36	106 900	230 500
NKI 90/26	820	NK100/26	525	IR9010026	90	100	120	26	82 500	168 700
NKI 90/36	1 140	NK100/36	725	IR9010036	90	100	120	36	109 800	244 200
NKI 95/26	860	NK105/26	545	IR9510526	95	105	125	26	84 700	177 500
NKI 95/36	1 190	NK105/36	760	IR9510536	95	105	125	36	112 800	257 900
NKI 100/30	1 040	NK110/30	660	IR10011030	100	110	130	30	105 900	239 300
NKI 100/40	1 380	NK110/40	880	IR10011040	100	110	130	40	133 400	323 600

NK type of 10mm or less inscribed circle diameter (Fw) is without oil hole.
NKI type of 8mm or less inscribed circle diameter (d) is without oil hole.

INTERCHANGE TABLE

IKO		INA		NTN		TORRINGTON(KOYO)	
WITH INNER RING	WITHOUT INNER RING	WITH INNER RING	WITHOUT INNER RING	WITH INNER RING	WITHOUT INNER RING	WITH INNER RING	WITHOUT INNER RING
TAFI	TAF	NKI	NK	NK+IR	NK	NKJ	NK
—	TAF657825	—	NK65/25	—	NK65/25R	—	NK65/25
—	TAF657835	—	NK65/35	—	NK65/35R	—	NK65/35
TAFI 608225	TAF688225	NKI 60/25	NK68/25	NK68/25R + IR606825	NK68/25R	NKJ 60/25	NK68/25
TAFI 608235	TAF688235	NKI 60/35	NK68/35	NK68/35R + IR606835	NK68/35R	NKJ 60/35	NK68/35
—	TAF708525	—	NK70/25	—	NK70/25R	—	NK70/25
—	TAF708535	—	NK70/35	—	NK70/35R	—	NK70/35
—	TAF739025	—	NK73/25	—	NK73/25R	—	NK73/25
TAFI 659035	TAF739035	NKI 65/35	NK73/35	NK73/35R + IR657335	NK73/35R	NKJ 65/35	NK73/35
—	TAF759225	—	NK75/25	—	NK75/25R	—	NK75/25
—	TAF759235	—	NK75/35	—	NK75/35R	—	NK75/35
TAFI 709525	TAF809525	NKI 70/25	NK80/25	NK80/25R + IR708025	NK80/25R	NKJ 70/25	NK80/25
TAFI 709535	TAF809535	NKI 70/35	NK80/35	NK80/35R + IR708035	NK80/35R	NKJ 70/35	NK80/35
TAFI 7510525	TAF8510525	NKI 75/25	NK85/25	NK85/25R + IR758525	NK85/25R	NKJ 75/25	NK85/25
TAFI 7510535	TAF8510535	NKI 75/35	NK85/35	NK85/35R + IR758535	NK85/35R	NKJ 75/35	NK85/35
TAFI 8011025	TAF9011025	NKI 80/25	NK90/25	NK90/25R + IR809025	NK90/25R	NKJ 80/25	NK90/25
TAFI 8011035	TAF9011035	NKI 80/35	NK90/35	NK90/35R + IR809035	NK90/35R	NKJ 80/35	NK90/35
TAFI 8511526	TAF9511526	NKI 85/26	NK95/26	NK95/26R + IR859526	NK95/26R	NKJ 85/26	NK95/26
TAFI 8511536	TAF9511536	NKI 85/36	NK95/36	NK95/36R + IR859536	NK95/36R	NKJ 85/36	NK95/36
TAFI 9012026	TAF10012026	NKI 90/26	NK100/26	NK100/26R + IR9010026	NK100/26R	NKJ 90/26	NK100/26
TAFI 9012036	TAF10012036	NKI 90/36	NK100/36	NK100/36R + IR9010036	NK100/36R	NKJ 90/36	NK100/36
TAFI 9512526	TAF10512526	NKI 95/26	NK105/26	NK105/26R + IR9510526	NK105/26R	NKJ 95/26	NK105/26
TAFI 9512536	TAF10512536	NKI 95/36	NK105/36	NK105/36R + IR9510536	NK105/36R	NKJ 95/36	NK105/36
TAFI 10013030	TAF11013030	NKI 100/30	NK110/30	NK110/30R + IR10011030	NK110/30R	NKJ 100/30	NK110/30
TAFI 10013040	TAF11013040	NKI 100/40	NK110/40	NK110/40R + IR10011040	NK110/40R	NKJ 100/40	NK110/40



MACHINED RING NEEDLE ROLLER BEARINGS

SEALED, WITH INNER RING
SEALED, WITHOUT INNER RING

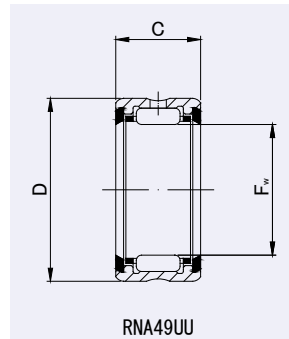
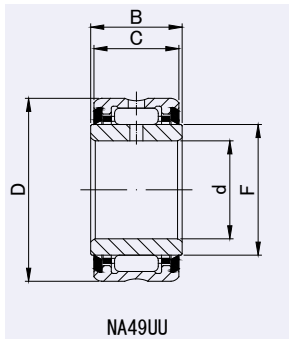

NA49UU, RNA49UU

DIMENSION TABLE

JNS NUMBER WITH INNER RING	Mass (Approx.)	JNS NUMBER WITHOUT INNER RING	Mass (Approx.)	JNS NUMBER Assembled INNER RING	Dimensions(mm)				Basic dynamic load rating	Basic static load rating
					d	Fw (F)	D	C		
NA 49UU	g	RNA 49UU	g	IRZ					Cr N	Cor N
NA 4900UU	25	RNA 4900UU	16	IRZ101414	10	14	22	13	8 000	8 500
NA 4901UU	28	RNA 4901UU	18	IRZ121614	12	16	24	13	8 400	9 300
NA 4902UU	36	RNA 4902UU	22	IRZ152014	15	20	28	13	9 600	11 700
NA 4903UU	40	RNA 4903UU	23	IRZ172214	17	22	30	13	10 300	13 100
NA 4904UU	78	RNA 4904UU	55	IRZ202518	20	25	37	17	17 900	20 500
NA 4905UU	93	RNA 4905UU	63	IRZ253018	25	30	42	17	20 300	25 100
NA 4906UU	106	RNA 4906UU	71	IRZ303518	30	35	47	17	21 600	28 400
NA 4907UU	179	RNA 4907UU	110	IRZ354221	35	42	55	20	30 100	46 300
NA 4908UU	245	RNA 4908UU	150	IRZ404823	40	48	62	22	37 200	58 300
NA 4909UU	290	RNA 4909UU	190	IRZ455223	45	52	68	22	38 800	63 400
NA 4910UU	300	RNA 4910UU	180	IRZ505823	50	58	72	22	41 300	71 100



INTERCHANGE

INTERCHANGE TABLE

IKO		INA		NTN		TORRINGTON(KOYO)	
WITH INNER RING	WITHOUT INNER RING	WITH INNER RING	WITHOUT INNER RING	WITH INNER RING	WITHOUT INNER RING	WITH INNER RING	WITHOUT INNER RING
NA 49UU	RNA 49UU	NA 49.2RS	RNA 49.2RS	NA 49LL	RNA 49LL	NA 49.2RS	RNA 49.2RS
NA4900UU	RNA4900UU	NA4900.2RS	RNA4900.2RS	NA4900LL	RNA4900LL	NA4900.2RS	RNA4900.2RS
NA4901UU	RNA4901UU	NA4901.2RS	RNA4901.2RS	NA4901LL	RNA4901LL	NA4901.2RS	RNA4901.2RS
NA4902UU	RNA4902UU	NA4902.2RS	RNA4902.2RS	NA4902LL	RNA4902LL	NA4902.2RS	RNA4902.2RS
NA4903UU	RNA4903UU	NA4903.2RS	RNA4903.2RS	NA4903LL	RNA4903LL	NA4903.2RS	RNA4903.2RS
NA4904UU	RNA4904UU	NA4904.2RS	RNA4904.2RS	NA4904LL	RNA4904LL	NA4904.2RS	RNA4904.2RS
NA4905UU	RNA4905UU	NA4905.2RS	RNA4905.2RS	NA4905LL	RNA4905LL	NA4905.2RS	RNA4905.2RS
NA4906UU	RNA4906UU	NA4906.2RS	RNA4906.2RS	NA4906LL	RNA4906LL	NA4906.2RS	RNA4906.2RS
NA4907UU	RNA4907UU	NA4907.2RS	RNA4907.2RS	NA4907LL	RNA4907LL	NA4907.2RS	RNA4907.2RS
NA4908UU	RNA4908UU	NA4908.2RS	RNA4908.2RS	NA4908LL	RNA4908LL	NA4908.2RS	RNA4908.2RS
NA4909UU	RNA4909UU	NA4909.2RS	RNA4909.2RS	NA4909LL	RNA4909LL	NA4909.2RS	RNA4909.2RS
NA4910UU	RNA4910UU	NA4910.2RS	RNA4910.2RS	NA4910LL	RNA4910LL	NA4910.2RS	RNA4910.2RS



INTERCHANGE

MACHINED RING NEEDLE ROLLER BEARINGS

SEALED, WITH INNER RING
SEALED, WITHOUT INNER RING

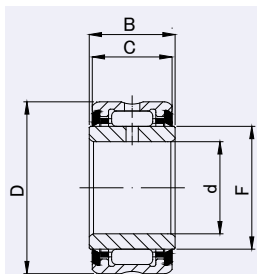

NA69UU($d \leq 30$)

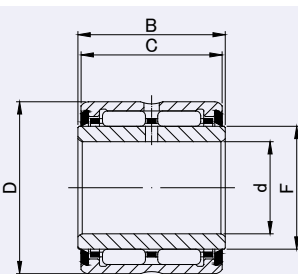

NA69UU

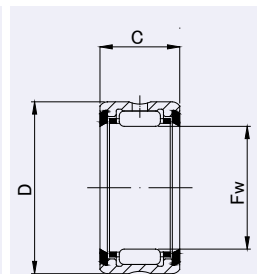

RNA69UU($F_w \leq 35$)

NA69UU, RNA69UU

DIMENSION TABLE

JNS NUMBER WITH INNER RING	Mass (Approx.)	JNS NUMBER WITHOUT INNER RING	Mass (Approx.)	JNS NUMBER Assembled INNER RING	Dimensions(mm)				Basic dynamic load rating	Basic static load rating
					d	Fw (F)	D	C		
NA 69UU	g	RNA 69UU	g	IRZ	d	Fw (F)	D	C	Cr N	Cor N
NA 6901UU	46	RNA 6901UU	30	IRZ121623	12	16	24	22	15 600	20 400
NA 6902UU	63	RNA 6902UU	38	IRZ152024	15	20	28	23	18 400	27 100
NA 6903UU	69	RNA 6903UU	40	IRZ172224	17	22	30	23	19 800	30 600
NA 6904UU	140	RNA 6904UU	96	IRZ202531	20	25	37	30	33 000	44 500
NA 6905UU	162	RNA 6905UU	110	IRZ253031	25	30	42	30	39 200	58 600
NA 6906UU	185	RNA 6906UU	130	IRZ303531	30	35	47	30	40 100	63 100
NA 6907UU	320	RNA 6907UU	200	IRZ354237	35	42	55	36	51 600	92 600
NA 6908UU	440	RNA 6908UU	270	IRZ404841	40	48	62	40	63 700	116 700
NA 6909UU	510	RNA 6909UU	355	IRZ455241	45	52	68	40	66 700	126 500
NA 6910UU	530	RNA 6910UU	320	IRZ505841	50	58	72	40	70 800	142 200



INTERCHANGE

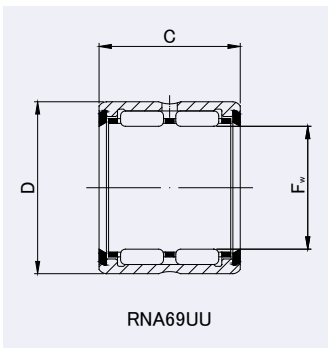

INTERCHANGE TABLE

IKO		INA		NTN		TORRINGTON(KOYO)	
WITH INNER RING	WITHOUT INNER RING	WITH INNER RING	WITHOUT INNER RING	WITH INNER RING	WITHOUT INNER RING	WITH INNER RING	WITHOUT INNER RING
NA 69UU	RNA 69UU	—	—	—	—	—	—
NA6901UU	RNA6901UU	—	—	—	—	—	—
NA6902UU	RNA6902UU	—	—	—	—	—	—
NA6903UU	RNA6903UU	—	—	—	—	—	—
NA6904UU	RNA6904UU	—	—	—	—	—	—
NA6905UU	RNA6905UU	—	—	—	—	—	—
NA6906UU	RNA6906UU	—	—	—	—	—	—
NA6907UU	RNA6907UU	—	—	—	—	—	—
NA6908UU	RNA6908UU	—	—	—	—	—	—
NA6909UU	RNA6909UU	—	—	—	—	—	—
NA6910UU	RNA6910UU	—	—	—	—	—	—



MACHINED RING NEEDLE ROLLER BEARINGS

WITH INNER RING
WITHOUT INNER RING

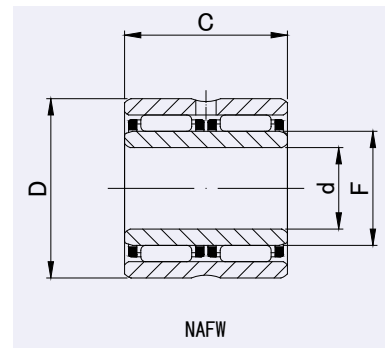
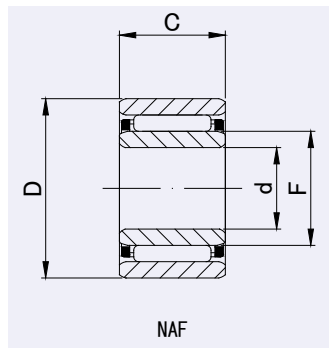

NAF, RNAF

DIMENSION TABLE

JNS NUMBER WITH INNER RING	Mass (Approx.)	JNS NUMBER WITHOUT INNER RING	Mass (Approx.)	JNS NUMBER Assembled INNER RING	Dimensions(mm)				Basic dynamic load rating	Basic static load rating
					d	Fw (F)	D	C		
NAF(W)	g	RNAF(W)	g	IR	d	Fw (F)	D	C	Cr N	Cor N
—	—	RNAF5108	3	—	—	5	10	8	2 500	2 000
—	—	RNAF6138	5.5	—	—	6	13	8	2 500	2 100
—	—	RNAF7148	6	—	—	7	14	8	2 900	2 600
—	—	RNAF81510	8	—	—	8	15	10	3 600	3 600
—	—	RNAFW81620	20	—	—	8	16	20	6 200	7 200
NAF61710	14	RNAF101710	10	IR61010	6	10	17	10	4 100	4 500
NAF72012	23	RNAF102012	19	IR71012	7	10	20	12	6 000	6 000
NAF92212	24	RNAF122212	19	IR91212	9	12	22	12	9 000	8 400
NAF102213	26	RNAF142213	18	IR101413	10	14	22	13	7 800	9 400
NAFW102220	40	RNAFW142220	28	IR101420	10	14	22	20	10 800	14 200
NAF102612	36	RNAF142612	29	IR101412	10	14	26	12	9 800	9 700
—	—	RNAF152313	20	—	—	15	23	13	8 200	10 200
—	—	RNAFW152320	31	—	—	15	23	20	11 400	15 400
NAF122413	30	RNAF162413	21	IR121613	12	16	24	13	8 600	11 000
NAFW122420	45	RNAFW162420	32	IR121620	12	16	24	20	11 900	16 700
NAF122812	40	RNAF162812	32	IR121612	12	16	28	12	10 500	10 900
—	—	RNAF172513	22	—	—	17	25	13	9 000	11 900
—	—	RNAFW172520	33	—	—	17	25	20	12 400	17 900
—	—	RNAF182613	23	—	—	18	26	13	9 300	12 700
—	—	RNAFW182620	35	—	—	18	26	20	12 800	19 100
—	—	RNAF183012	35	—	—	18	30	12	11 800	13 000
—	—	RNAFW183024	70	—	—	18	30	24	20 200	26 200
NAF152813	37	RNAF202813	25	IR152013	15	20	28	13	9 600	13 500
NAFW152826	76	RNAFW202826	50	IR152026	15	20	28	26	16 500	27 100
NAF153212	51	RNAF203212	37	IR152012	15	20	32	12	12 400	14 300
—	—	RNAFW203224	75	—	—	20	32	24	21 200	28 600
NAF173013	43	RNAF223013	27	IR172213	17	22	30	13	10 200	15 200
NAFW173026	85	RNAFW223026	54	IR172226	17	22	30	26	17 600	30 300
NAF173516	77	RNAF223516	59	IR172216	17	22	35	16	17 600	20 900
NAFW173532	155	RNAFW223532	117	IR172232	17	22	35	32	30 200	41 900
NAF203517	75	RNAF253517	51	IR202517	20	25	35	17	17 300	26 600
NAFW203526	114	RNAFW253526	78	IR202526	20	25	35	26	22 500	37 200
NAF203716	80	RNAF253716	57	IR202516	20	25	37	16	19 400	24 500
NAFW203732	158	RNAFW253732	114	IR202532	20	25	37	32	33 200	49 000
—	—	RNAF284016	63	—	—	28	40	16	20 100	26 500
—	—	RNAFW284032	125	—	—	28	40	32	34 400	53 000



INTERCHANGE

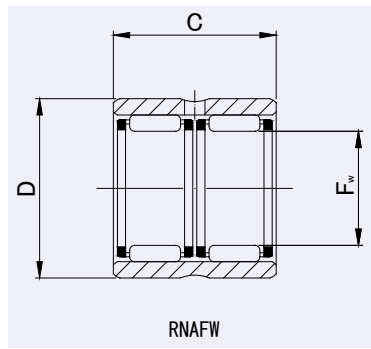
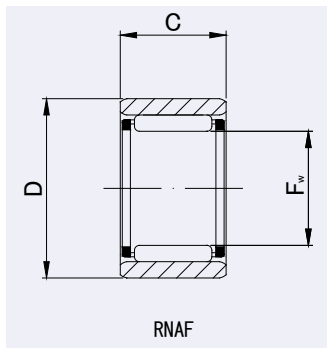

INTERCHANGE TABLE

INA		IKO		NTN		TORRINGTON(KOYO)	
WITH INNER RING	WITHOUT INNER RING	WITH INNER RING	WITHOUT INNER RING	WITH INNER RING	WITHOUT INNER RING	WITH INNER RING	WITHOUT INNER RING
NAO	RNAO	NAF(W)	RNAF(W)	NAO	RNAO	NAO	RNAO
—	RNAO5X10X8 TN	—	RNAF5108N	—	RNAO-5X10X8 T2	—	—
—	RNAO6X13X8 TN	—	RNAF6138N	—	RNAO-6X13X8 T2	—	RNAO6X13X8 TN
—	RNAO7X14X8 TN	—	RNAF7148N	—	RNAO-7X14X8 T2	—	RNAO7X14X8 TN
—	RNAO8X15X10 TN	—	RNAF81510	—	RNAO-8X15X10 T2	—	RNAO8X15X10
—	—	—	RNAFW81620	—	RNAO-8X16X20ZW T2	—	—
NAO6X17X10 TN	RNAO10X17X10 TN	NAF61710	RNAF101710	NAO-6X17X10 T2	RNAO-10X17X10 T2	NAO6X17X10	RNAO10X17X10
—	—	NAF72012	RNAF102012	NAO-7X20X12	RNAO-10X20X12	—	—
NAO9X22X12 TN	RNAO12X22X12 TN	NAF92212	RNAF122212	NAO-9X22X12	RNAO-12X22X12	—	—
—	—	NAF102213	RNAF142213	NAO-10X22X13	RNAO-14X22X13	NAO10X22X13	RNAO14X22X13
—	—	NAFW102220	RNAFW142220	NAO-10X22X20 ZW	RNAO-14X22X20ZW	NAO10X22X20	RNAO14X22X20
—	—	NAF102612	RNAF142612	NAO-10X26X12	RNAO-14X26X12	NAO10X26X12	RNAO14X26X12
—	RNAO15X23X13	—	RNAF152313	—	RNAO-15X23X13	—	RNAO15X23X13
—	—	—	RNAFW152320	—	RNAO-15X23X20ZW	—	RNAO15X23X20
NAO12X24X13	RNAO16X24X13	NAF122413	RNAF162413	NAO-12X24X13	RNAO-16X24X13	NAO12X24X13	RNAO16X24X13
NAO12X24X20	RNAO16X24X20	NAFW122420	RNAFW162420	NAO-12X24X20 ZW	RNAO-16X24X20ZW	NAO12X24X20	RNAO16X24X20
NAO12X28X12	RNAO16X28X12	NAF122812	RNAF162812	NAO-12X28X12	RNAO-16X28X12	NAO12X28X12	RNAO16X28X12
—	RNAO17X25X13	—	RNAF172513	—	RNAO-17X25X13	—	RNAO17X25X13
—	—	—	RNAFW172520	—	RNAO-17X25X20ZW	—	RNAO17X25X20
—	—	—	RNAF182613	—	RNAO-18X26X13	—	RNAO18X26X13
—	—	—	RNAFW182620	—	RNAO-18X26X20ZW	—	RNAO18X26X20
—	—	—	RNAF183012	—	RNAO-18X30X12	—	—
—	RNAO18X30X24	—	RNAFW183024	—	RNAO-18X30X24ZW	—	RNAO18X30X24
NAO15X28X13	RNAO20X28X13	NAF152813	RNAF202813	NAO-15X28X13	RNAO-20X28X13	NAO15X28X13	RNAO20X28X13
—	RNAO20X28X26	NAFW152826	RNAFW202826	NAO-15X28X26 ZW	RNAO-20X28X26ZW	NAO15X28X26	RNAO20X28X26
NAO15X32X12	RNAO20X32X12	NAF153212	RNAF203212	NAO-15X32X12	RNAO-20X32X12	NAO15X32X12	RNAO20X32X12
—	—	—	RNAFW203224	—	RNAO-20X32X24ZW	—	RNAO20X32X24
NAO17X30X13	RNAO22X30X13	NAF173013	RNAF223013	NAO-17X30X13	RNAO-22X30X13	NAO17X30X13	RNAO22X30X13
—	—	NAFW173026	RNAFW223026	NAO-17X30X26 ZW	RNAO-22X30X26ZW	NAO17X30X26	RNAO22X30X26
NAO17X35X16	RNAO22X35X16	NAF173516	RNAF223516	NAO-17X35X16	RNAO-22X35X16	NAO17X35X16	RNAO22X35X16
—	—	NAFW173532	RNAFW223532	NAO-17X35X32 ZW	RNAO-22X35X32ZW	NAO17X35X32	RNAO22X35X32
NAO20X35X17	RNAO25X35X17	NAF203517	RNAF253517	NAO-20X35X17	RNAO-25X35X17	NAO20X35X17	RNAO25X35X17
—	RNAO25X35X26	NAFW203526	RNAFW253526	NAO-20X35X26 ZW	RNAO-25X35X26ZW	NAO20X35X26	RNAO25X35X26
NAO20X37X16	RNAO25X37X16	NAF203716	RNAF253716	NAO-20X37X16	RNAO-25X37X16	NAO20X37X16	RNAO25X37X16
—	RNAO25X37X32	NAFW203732	RNAFW253732	NAO-20X37X32 ZW	RNAO-25X37X32ZW	NAO20X37X32	RNAO25X37X32
—	—	—	RNAF284016	—	RNAO-28X40X16	—	RNAO28X40X16
—	—	—	RNAFW284032	—	RNAO-28X40X32ZW	—	RNAO28X40X32



INTERCHANGE

MACHINED RING NEEDLE ROLLER BEARINGS WITH INNER RING WITHOUT INNER RING

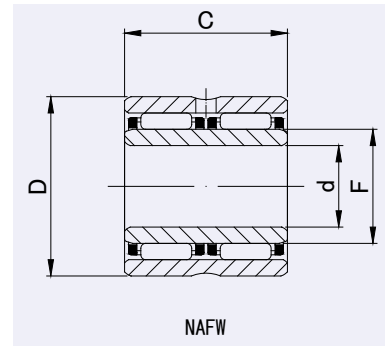
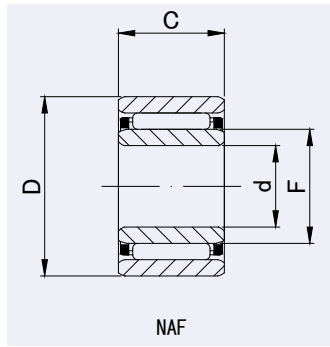

NAF, RNAF

DIMENSION TABLE

JNS NUMBER WITH INNER RING	Mass (Approx.)	JNS NUMBER WITHOUT INNER RING	Mass (Approx.)	JNS NUMBER Assembled INNER RING	Dimensions(mm)				Basic dynamic load rating	Basic static load rating
					d	Fw (F)	D	C		
NAF(W)	g	RNAF(W)	g	IR	d	Fw (F)	D	C	Cr N	Cor N
NAF254017	88	RNAF304017	59	IR253017	25	30	40	17	18 600	31 100
NAFW254026	136	RNAFW304026	91	IR253026	25	30	40	26	24 200	43 400
NAF254216	94	RNAF304216	66	IR253016	25	30	42	16	20 800	28 300
NAFW254232	187	RNAFW304232	132	IR253032	25	30	42	32	35 700	56 800
NAF304517	100	RNAF354517	68	IR303517	30	35	45	17	20 500	36 900
NAFW304526	155	RNAFW354526	103	IR303526	30	35	45	26	26 600	51 600
NAF304716	108	RNAF354716	76	IR303516	30	35	47	16	23 000	33 800
NAFW304732	215	RNAFW354732	151	IR303532	30	35	47	32	39 500	67 800
NAF355017	115	RNAF405017	75	IR354017	35	40	50	17	22 200	42 700
NAFW355034	230	RNAFW405034	152	IR354034	35	40	50	34	38 000	85 300
NAF355520	188	RNAF405520	142	IR354020	35	40	55	20	31 500	48 000
NAFW355540	375	RNAFW405540	280	IR354040	35	40	55	40	53 900	96 000
NAF405517	129	RNAF455517	84	IR404517	40	45	55	17	23 200	47 200
NAFW405534	255	RNAFW455534	167	IR404534	40	45	55	34	39 900	94 200
NAF406220	236	RNAF456220	185	IR404520	40	45	62	20	33 200	53 300
NAFW406240	475	RNAFW456240	370	IR404540	40	45	62	40	57 000	106 900
NAF456220	197	RNAF506220	139	IR455020	45	50	62	20	27 100	59 300
NAFW456240	389	RNAFW506240	276	IR455040	45	50	62	40	46 400	118 700
—	—	RNAF506520	170	—	—	50	65	20	35 900	61 100
—	—	RNAFW506540	345	—	—	50	65	40	61 500	122 600
NAF506820	230	RNAF556820	167	IR505520	50	55	68	20	28 500	66 000
NAFW506840	465	RNAFW556840	330	IR505540	50	55	68	40	48 900	132 400
NAF457220	340	RNAF557220	215	IR455520	45	55	72	20	37 400	66 400
NAFW457240	685	RNAFW557240	435	IR455540	45	55	72	40	64 100	132 400
NAF507820	390	RNAF607820	255	IR506020	50	60	78	20	38 900	71 700
NAFW507840	775	RNAFW607840	510	IR506040	50	60	78	40	66 700	143 200
NAF558530	680	RNAF658530	465	IR556530	55	65	85	30	59 300	127 500
NAFW558560	1 380	RNAFW658560	950	IR556560	55	65	85	60	102 000	254 000
NAF609030	740	RNAF709030	500	IR607030	60	70	90	30	61 200	135 300
NAFW609060	1 470	RNAFW709060	1 000	IR607060	60	70	90	60	104 900	271 600
NAF659530	800	RNAF759530	530	IR657530	65	75	95	30	63 200	144 200
NAFW659560	1 570	RNAFW759560	1 050	IR657560	65	75	95	60	108 900	289 300
NAF7010030	840	RNAF8010030	560	IR708030	70	80	100	30	64 900	153 000
NAFW7010060	1 670	RNAFW8010060	1 120	IR708060	70	80	100	60	111 800	306 000
NAF7510530	890	RNAF8510530	590	IR758530	75	85	105	30	66 600	160 800



INTERCHANGE

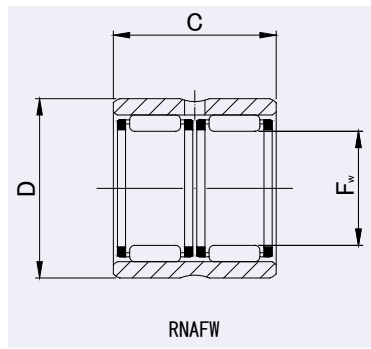
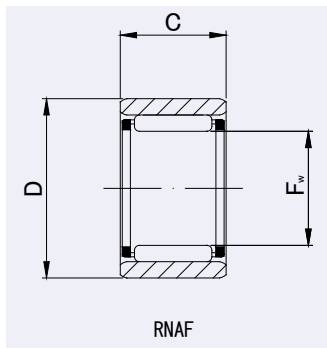

INTERCHANGE TABLE

INA		IKO		NTN		TORRINGTON(KOYO)	
WITH INNER RING	WITHOUT INNER RING	WITH INNER RING	WITHOUT INNER RING	WITH INNER RING	WITHOUT INNER RING	WITH INNER RING	WITHOUT INNER RING
NAO	RNAO	NAF(W)	RNAF(W)	NAO	RNAO	NAO	RNAO
NAO25X40X17	RNAO30X40X17	NAF254017	RNAF304017	NAO-25X40X17	RNAO-30X40X17	NAO25X40X17	RNAO30X40X17
—	RNAO30X40X26	NAFW254026	RNAFW304026	NAO-25X40X26 ZW	RNAO-30X40X26ZW	NAO25X40X26	RNAO30X40X26
NAO25X42X16	RNAO30X42X16	NAF254216	RNAF304216	NAO-25X42X16	RNAO-30X42X16	NAO25X42X16	RNAO30X42X16
NAO25X42X32	RNAO30X42X32	NAFW254232	RNAFW304232	NAO-25X42X32 ZW	RNAO-30X42X32ZW	NAO25X42X32	RNAO30X42X32
NAO30X45X17	RNAO35X45X17	NAF304517	RNAF354517	NAO-30X45X17	RNAO-35X45X17	NAO30X45X17	RNAO35X45X17
NAO30X45X26	RNAO35X45X26	NAFW304526	RNAFW354526	NAO-30X45X26 ZW	RNAO-35X45X26ZW	NAO30X45X26	RNAO35X45X26
NAO30X47X16	RNAO35X47X16	NAF304716	RNAF354716	NAO-30X47X16	RNAO-35X47X16	NAO30X47X16	RNAO35X47X16
—	RNAO35X47X32	NAFW304732	RNAFW354732	NAO-30X47X32 ZW	RNAO-35X47X32ZW	NAO30X47X32	RNAO35X47X32
NAO35X50X17	RNAO40X50X17	NAF355017	RNAF405017	NAO-35X50X17	RNAO-40X50X17	NAO35X50X17	RNAO40X50X17
—	RNAO40X50X34	NAFW355034	RNAFW405034	NAO-35X50X34 ZW	RNAO-40X50X34ZW	NAO35X50X34	RNAO40X50X34
NAO35X55X20	RNAO40X55X20	NAF355520	RNAF405520	NAO-35X55X20	RNAO-40X55X20	NAO35X55X20	RNAO40X55X20
—	RNAO40X55X40	NAFW355540	RNAFW405540	NAO-35X55X40 ZW	RNAO-40X55X40ZW	NAO35X55X40	RNAO40X55X40
NAO40X55X17	RNAO45X55X17	NAF405517	RNAF455517	NAO-40X55X17	RNAO-45X55X17	NAO40X55X17	RNAO45X55X17
—	—	NAFW405534	RNAFW455534	NAO-40X55X34 ZW	RNAO-45X55X34ZW	NAO40X55X34	RNAO45X55X34
—	—	NAF406220	RNAF456220	NAO-40X62X20	RNAO-45X62X20	NAO40X62X20	RNAO45X62X20
—	RNAO45X62X40	NAFW406240	RNAFW456240	NAO-40X62X40 ZW	RNAO-45X62X40ZW	NAO40X62X40	RNAO45X62X40
—	RNAO50X62X20	NAF456220	RNAF506220	NAO-45X62X20	RNAO-50X62X20	NAO45X62X20	RNAO50X62X20
—	—	NAFW456240	RNAFW506240	NAO-45X62X40 ZW	RNAO-50X62X40ZW	NAO45X62X40	RNAO50X62X40
—	RNAO50X65X20	—	RNAF506520	—	RNAO-50X65X20	—	RNAO50X65X20
—	RNAO50X65X40	—	RNAFW506540	—	RNAO-50X65X40ZW	—	RNAO50X65X40
NAO50X68X20	RNAO55X68X20	NAF506820	RNAF556820	NAO-50X68X20	RNAO-55X68X20	NAO50X68X20	RNAO55X68X20
—	—	NAFW506840	RNAFW556840	NAO-50X68X40 ZW	RNAO-55X68X40ZW	NAO50X68X40	RNAO55X68X40
—	—	NAF457220	RNAF557220	NAO-45X72X20	RNAO-55X72X20	NAO45X72X20	RNAO55X72X20
—	—	NAFW457240	RNAFW557240	NAO-45X72X40 ZW	RNAO-55X72X40ZW	NAO45X72X40	RNAO55X72X40
NAO50X78X20	RNAO60X78X20	NAF507820	RNAF607820	NAO-50X78X20	RNAO-60X78X20	NAO50X78X20	RNAO60X78X20
—	RNAO60X78X40	NAFW507840	RNAFW607840	NAO-50X78X40 ZW	RNAO-60X78X40ZW	NAO50X78X40	RNAO60X78X40
—	RNAO65X85X30	NAF558530	RNAF658530	NAO-55X85X30	RNAO-65X85X30	NAO55X85X30	RNAO65X85X30
—	—	NAFW558560	RNAFW658560	NAO-55X85X60 ZW	RNAO-65X85X60ZW	NAO55X85X60	RNAO65X85X60
—	RNAO70X90X30	NAF609030	RNAF709030	NAO-60X90X30	RNAO-70X90X30	NAO60X90X30	RNAO70X90X30
—	—	NAFW609060	RNAFW709060	NAO-60X90X60 ZW	RNAO-70X90X60ZW	NAO60X90X60	RNAO70X90X60
—	—	NAF659530	RNAF759530	NAO-65X95X30	RNAO-75X95X30	NAO65X95X30	RNAO75X95X30
—	—	NAFW659560	RNAFW759560	NAO-65X95X60 ZW	RNAO-75X95X60ZW	NAO65X95X60	RNAO75X95X60
NAO70X100X30	RNAO80X100X30	NAF7010030	RNAF8010030	NAO-70X100X30	RNAO-80X100X30	NAO70X100X30	RNAO80X100X30
—	—	NAFW7010060	RNAFW8010060	NAO-70X100X60 ZW	RNAO-80X100X60ZW	NAO70X100X60	RNAO80X100X60
—	—	NAF7510530	RNAF8510530	NAO-75X105X30	RNAO-85X105X30	—	RNAO85X105X30



INTERCHANGE

MACHINED RING NEEDLE ROLLER BEARINGS WITH INNER RING WITHOUT INNER RING

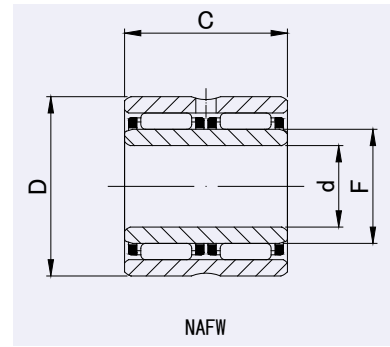
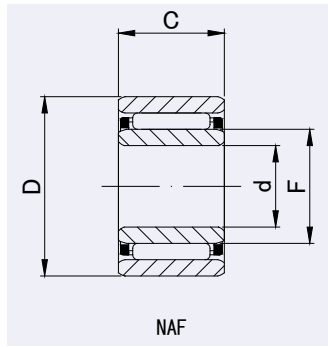

NAF, RNAF

DIMENSION TABLE

JNS NUMBER WITH INNER RING	Mass (Approx.)	JNS NUMBER WITHOUT INNER RING	Mass (Approx.)	JNS NUMBER Assembled INNER RING	Dimensions(mm)				Basic dynamic load rating	Basic static load rating
					d	Fw (F)	D	C		
NAF(W)	g	RNAF(W)	g	IR	d	Fw (F)	D	C	Cr N	Cor N
NAF8011030	930	RNAF9011030	620	IR809030	80	90	110	30	69 500	173 600
NAF8511530	970	RNAF9511530	650	IR859530	85	95	115	30	70 900	182 400
NAF9012030	1 040	RNAF10012030	690	IR9010030	90	100	120	30	72 600	191 200



INTERCHANGE

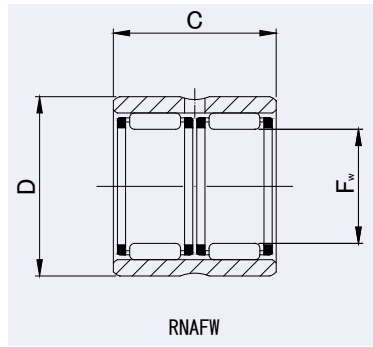
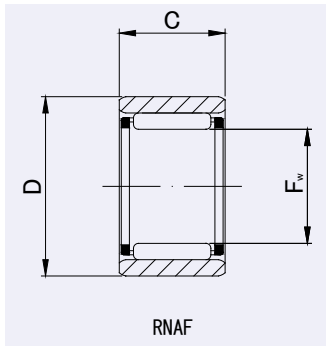

INTERCHANGE TABLE

INA		IKO		NTN		TORRINGTON(KOYO)	
WITH INNER RING	WITHOUT INNER RING	WITH INNER RING	WITHOUT INNER RING	WITH INNER RING	WITHOUT INNER RING	WITH INNER RING	WITHOUT INNER RING
NAO	RNAO	NAF(W)	RNAF(W)	NAO	RNAO	NAO	RNAO
NAO80X110X30	RNAO90X110X30	NAF8011030	RNAF9011030	NAO-80X110X30	RNAO-90X110X30	NAO80X110X30	—
—	—	NAF8511530	RNAF9511530	NAO-85X115X30	RNAO-95X115X30	NAO85X115X30	—
NAO90X120X30	RNAO100X120X30	NAF9012030	RNAF10012030	NAO-90X120X30	RNAO-100X120X30	NAO90X120X30	RNAO100X120X30



INNER RINGS

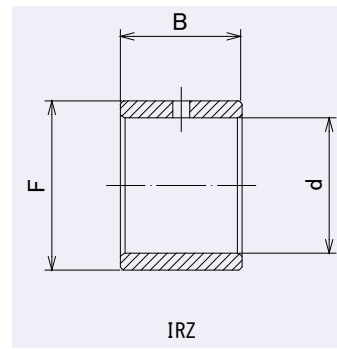
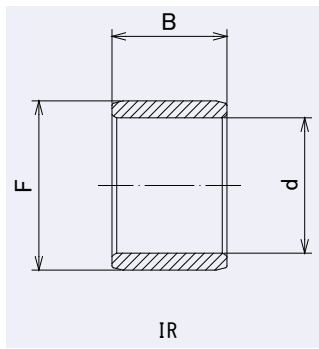

IR, IRZ

DIMENSION TABLE

INTERCHANGE TABLE

JNS NUMBER INNER RING	Mass (Approx.)	Dimensions(mm)			JNS USABLE BEARING NUMBER		IKO
		IR	IRZ	g			d
IR 5812	3	5	8	12	NK 8/12	—	LRT5812
IR 5816	4	5	8	16	NK 8/16	—	LRT5816
IR 6810	1.7	6	8	10	RNA 496	—	LRT6810
IR 6912	3.2	6	9	12	NK 9/12	—	LRT6912
IR 6916	4.3	6	9	16	NK 9/16	—	LRT6916
IR 61010	4	6	10	10	RNAF 101710	—	LRT61010
IR 7910	1.9	7	9	10	RNA 497	—	LRT7910
IR 71010.5	3.2	7	10	10.5	—	—	IRT710
IR 71012	3.6	7	10	12	NK 10/12	RNAF 102012	LRT71012
IR 71012.5	3.9	7	10	12.5	—	—	IRT712
IR 71015.5	4.8	7	10	15.5	—	—	IRT715
IR 71016	5	7	10	16	NK 10/16	—	LRT71016
IR 81011	2.4	8	10	11	RNA 498	—	LRT81011
IR 81210	4.8	8	12	10	—	—	—
IR 81210.5	5.1	8	12	10.5	—	—	IRT810
IR 81212.5	6	8	12	12.5	—	—	IRT812
IR 81215.5	7.5	8	12	15.5	—	—	IRT815
IR 91211	3.1	9	12	11	RNA 499	—	LRT91211
IR 91212	4.5	9	12	12	NK 12/12	RNAF 122212	LRT91212
IR 91216	6	9	12	16	NK 12/16	—	LRT91216
IR 101312.5	5.2	10	13	12.5	—	—	IRT1012
IR 101412	7	10	14	12	RNAF 142612	—	LRT101412
IR 101412.5	7.2	10	14	12.5	—	—	IRT1012-2
IR 101413	7.5	10	14	13	RNA 4900	RNAF 142213	LRT101413
IRZ 101414	8	10	14	14	RNA 4900UU	—	LRTZ101414
IR 101416	9	10	14	16	NK 14/16	—	LRT101416
IR 101416.5	9.6	10	14	16.5	—	—	IRT1016-2
IR 101420	11.5	10	14	20	NK 14/20	RNAFW 142220	LRT101420
IR 101420.5	11.9	10	14	20.5	—	—	IRT1020-2
IR 101510.5	7.9	10	15	10.5	—	—	IRT1010-1
IR 101515.5	11.7	10	15	15.5	—	—	IRT1015-1
IR 101520.5	15.5	10	15	20.5	—	—	IRT1020-1
IR 101525.5	19.3	10	15	25.5	—	—	IRT1025-1
IR 121512.5	6.1	12	15	12.5	—	—	IRT1212
IR 121516	7.8	12	15	16	—	—	—
IR 121516.5	8.1	12	15	16.5	—	—	LRT121516
IR 121522.5	11	12	15	22.5	—	—	IRT1222



INTERCHANGE

INA	NTN	TORRINGTON(KOYO)
IR	IR	JR JRZ
IR5X8X12	IR5X8X12	JR5X8X12
IR5X8X16	IR5X8X16	JR5X8X16
IR6X8X10	IR6X8X10	—
IR6X9X12	IR6X9X12	JR6X9X12
IR6X9X16	IR6X9X16	JR6X9X16
IR6X10X10	IR6X10X10	JR6X10X10
IR7X9X10	IR7X9X10	—
IR7X10X10.5	IR7X10X10.5	JR7X10X10.5
IR7X10X12	IR7X10X12	JR7X10X12
—	—	—
—	—	—
IR7X10X16	IR7X10X16	JR7X10X16
IR8X10X11	IR8X10X11	—
IR8X12X10	IR8X12X10	JR8X12X10
IR8X12X10.5	IR8X12X10.5	JR8X12X10.5
IR8X12X12.5	IR8X12X12.5	JR8X12X12.5
—	—	—
IR9X12X11	IR9X12X11	—
IR9X12X12	IR9X12X12	JR9X12X12
IR9X12X16	IR9X12X16	JR9X12X16
IR10X13X12.5	IR10X13X12.5	JR10X13X12.5
IR10X14X12	IR10X14X12	JR10X14X12
—	—	—
IR10X14X13	IR10X14X13	JR10X14X13
IR10X14X14	IR10X14X14D	JRZ10X14X14JS1
IR10X14X16	IR10X14X16	JR10X14X16
—	—	—
IR10X14X20	IR10X14X20	JR10X14X20
—	—	—
—	—	—
—	IR10X15X15.5	—
—	IR10X15X20.5	—
—	—	—
IR12X15X12.5	IR12X15X12.5	—
IR12X15X16	IR12X15X16	—
—	—	JR12X15X16.5
IR12X15X22.5	—	JR12X15X22.5



INTERCHANGE

INNER RINGS

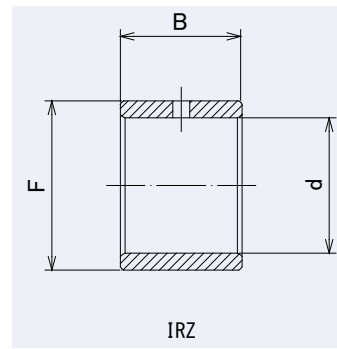
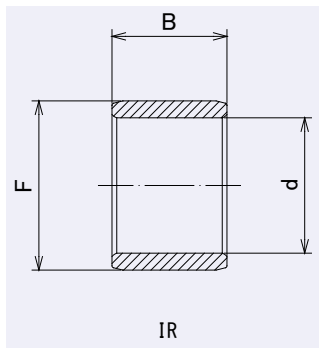

IR, IRZ

DIMENSION TABLE

INTERCHANGE TABLE

JNS NUMBER INNER RING	Mass (Approx.)	Dimensions(mm)			JNS USABLE BEARING NUMBER		IKO
		IR	IRZ	g			d
IR 121612	8	12	16	12	RNAF 162812	—	LRT121612
IR 121612.5	8.5	12	16	12.5	—	—	IRT1212-1
IR 121613	8.5	12	16	13	RNA 4901	RNAF 162413	LRT121613
IRZ 121614	9.6	12	16	14	RNA 4901UU	—	LRTZ121614
IR 121616	10.5	12	16	16	NK 16/16	—	LRT121616
IR 121616.5	11.2	12	16	16.5	—	—	IRT1216-1
IR 121620	13.5	12	16	20	NK 16/20	RNAFW 162420	LRT121620
IR 121620.5	13.9	12	16	20.5	—	—	IRT1220-1
IR 121622	14.5	12	16	22	RNA 6901	—	LRT121622
IR 121622.5	15.2	12	16	22.5	—	—	IRT1222-1
IRZ 121623	15.5	12	16	23	RNA 6901UU	—	LRTZ121623
IR 121715.5	13.6	12	17	15.5	—	—	IRT1215-2
IR 121720.5	18	12	17	20.5	—	—	IRT1220-2
IR 141717	9.5	14	17	17	—	—	LRT141717
IR 151812.5	7.5	15	18	12.5	—	—	IRT1512
IR 151815.5	9.3	15	18	15.5	—	—	IRT1515
IR 151816.5	9.9	15	18	16.5	—	—	IRT1516
IR 151820.5	12.3	15	18	20.5	—	—	IRT1520
IR 151825.5	15.2	15	18	25.5	—	—	IRT1525
IR 151916	12.5	15	19	16	NK 19/16	—	LRT151916
IR 151916.5	13.6	15	19	16.5	—	—	IRT1516-1
IR 151920	16	15	19	20	NK 19/20	—	LRT151920
IR 151920.5	12.3	15	19	20.5	—	—	IRT1520-1
IR 152012	12	15	20	12	RNAF 203212	—	LRT152012
IR 152013	13.5	15	20	13	RNA 4902	RNAF 202813	LRT152013
IRZ 152014	14.5	15	20	14	RNA 4902UU	—	LRTZ152014
IR 152015.5	16.4	15	20	15.5	—	—	IRT1515-2
IR 152018	19	15	20	18	RNA 5902	—	—
IR 152020.5	21.5	15	20	20.5	—	—	IRT1520-2
IR 152023	24	15	20	23	RNA 6902	—	LRT152023
IRZ 152024	25	15	20	24	RNA 6902UU	—	LRTZ152024
IR 152026	28	15	20	26	RNAFW 202826	—	LRT152026
IR 172016.5	11.1	17	20	16.5	—	—	IRT1716
IR 172020	14	17	20	20	—	—	—
IR 172020.5	13.7	17	20	20.5	—	—	IRT1720
IR 172030.5	20.5	17	20	30.5	—	—	IRT1730
IR 172215.5	18.3	17	22	15.5	—	—	IRT1715-2



INTERCHANGE

INA	NTN	TORRINGTON(KOYO)
IR	IR	JR JRZ
IR12X16X12	IR12X16X12	JR12X16X12
—	—	—
IR12X16X13	IR12X16X13	JR12X16X13
IR12X16X14	IR12X16X14D	JRZ12X16X14JS1
IR12X16X16	IR12X16X16	JR12X16X16
—	—	—
IR12X16X20	IR12X16X20	JR12X16X20
—	—	—
IR12X16X22	IR12X16X22	JR12X16X22
—	—	—
—	—	—
—	—	—
—	IR12X17X20.5	—
IR14X17X17	IR14X17X17	—
IR15X18X12.5	IR15X18X12.5	—
—	—	—
IR15X18X16.5	IR15X18X16.5	JR15X18X16.5
—	IR15X18X20.5	—
—	IR15X18X25.5	—
IR15X19X16	IR15X19X16	JR15X19X16
—	—	—
IR15X19X20	IR15X19X20	JR15X19X20
—	—	—
IR15X20X12	IR15X20X12	JR15X20X12
IR15X20X13	IR15X20X13	JR15X20X13
IR15X20X14	IR15X20X14D	JRZ15X20X14JS1
—	—	—
—	IR15X20X18	—
—	IR15X20X20.5	—
IR15X20X23	IR15X20X23	JR15X20X23
—	—	—
IR15X20X26	IR15X20X26	JR15X20X26
IR17X20X16.5	IR17X20X16.5	JR17X20X16.5
IR17X20X20	IR17X20X20	JR17X20X20
IR17X20X20.5	IR17X20X20.5	JR17X20X20.5
IR17X20X30.5	IR17X20X30.5	JR17X20X30.5
—	—	—



INTERCHANGE

INNER RINGS

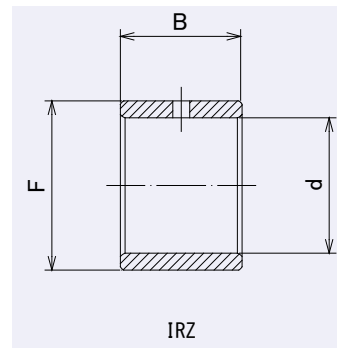
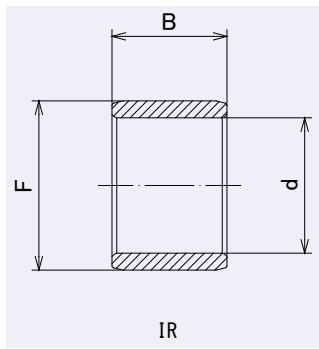

IR, IRZ

DIMENSION TABLE

INTERCHANGE TABLE

JNS NUMBER INNER RING	Mass (Approx.) g	Dimensions(mm)			JNS USABLE BEARING NUMBER		IKO
		d	F	B			LRT / IRT LRTZ
IR 172116	14.5	17	21	16	NK 21/16	—	LRT172116
IR 172216.5	19.4	17	22	16.5	—	—	IRT1716-2
IR 172120	18	17	21	20	NK 21/20	—	LRT172120
IR 172213	15.5	17	22	13	RNA 4903	RNAF 223013	LRT172213
IRZ 172214	16.5	17	22	14	RNA 4903UU	—	LRTZ172214
IR 172216	19	17	22	16	RNAF 223516	—	LRT172216
IR 172218	21	17	22	18	RNA 5903	—	—
IR 172223	26.5	17	22	23	RNA 6903	—	LRT172223
IRZ 172224	28	17	22	24	RNA 6903UU	—	LRTZ172224
IR 172225.5	30	17	22	25.5	—	—	IRT1725-2
IR 172226	31	17	22	26	RNAFW 223026	—	LRT172226
IR 172232	38	17	22	32	RNAFW 223532	—	LRT172232
IR 202416	16.5	20	24	16	NK 24/16	—	LRT202416
IR 202416.5	17.5	20	24	16.5	—	—	IRT2016
IR 202420	20.5	20	24	20	NK 24/20	—	LRT202420
IR 202420.5	22	20	24	20.5	—	—	IRT2020
IR 202510.5	14.3	20	25	10.5	—	—	IRT2010-1
IR 202515.5	21	20	25	15.5	—	—	IRT2015-1
IR 202516	22	20	25	16	RNAF 253716	—	LRT202516
IR 202517	23	20	25	17	RNA 4904	RNAF 253517	LRT202517
IRZ 202518	24	20	25	18	RNA 4904UU	—	LRTZ202518
IR 202520	27	20	25	20	—	—	—
IR 202520.5	28	20	25	20.5	—	—	LRT202520
IR 202523	31	20	25	23	RNA 5904	—	—
IR 202525.5	34.5	20	25	25.5	—	—	IRT2025-1
IR 202526	36	20	25	26	RNAFW 253526	—	LRT202526
IR 202526.5	36	20	25	26.5	—	—	IRT2026-1
IR 202530	40.5	20	25	30	RNA 6904	—	LRT202530
IRZ 202531	41.5	20	25	31	RNA 6904UU	—	LRTZ202531
IR 202532	44	20	25	32	RNAFW 253732	—	LRT202532
IR 222616	17.5	22	26	16	NK 26/16	—	LRT222616
IR 222620	24	22	26	20	NK 26/20	—	LRT222620
IR 222817	30.5	22	28	17	RNA 49/22	—	LRT222817
IR 222820.5	37	22	28	20.5	—	—	IRT2220-1
IR 222823	42	22	28	23	RNA 59/22	—	—
IR 222830	55	22	28	30	RNA 69/22	—	LRT222830
IR 252920	25	25	29	20	NK 29/20	—	LRT252920



INTERCHANGE

INA	NTN	TORRINGTON(KOYO)
IR	IR	JR JRZ
IR17X21X16	IR17X21X16	JR17X21X16
—	—	—
IR17X21X20	IR17X21X20	JR17X21X20
IR17X22X13	IR17X22X13	JR17X22X13
IR17X22X14	IR17X22X14D	JRZ17X22X14JS1
IR17X22X16	IR17X22X16	JR17X22X16
—	IR17X22X18	—
IR17X22X23	IR17X22X23	JR17X22X23
—	—	—
—	—	—
IR17X22X26	IR17X22X26	JR17X22X26
IR17X22X32	IR17X22X32	JR17X22X32
IR20X24X16	IR20X24X16	JR20X24X16
—	—	—
IR20X24X20	IR20X24X20	JR20X24X20
—	—	—
—	—	—
—	—	—
IR20X25X16	IR20X25X16	JR20X25X16
IR20X25X17	IR20X25X17	JR20X25X17
IR20X25X18	IR20X25X18D	JRZ20X25X18JS1
IR20X25X20	IR20X25X20	—
IR20X25X20.5	IR20X25X20.5	JR20X25X20.5
—	IR20X25X23	—
—	—	—
IR20X25X26	IR20X25X26	JR20X25X26
IR20X25X26.5	IR20X25X26.5	JR20X25X26.5
IR20X25X30	IR20X25X30	JR20X25X30
—	—	—
IR20X25X32	IR20X25X32	JR20X25X32
IR22X26X16	IR22X26X16	JR22X26X16
IR22X26X20	IR22X26X20	JR22X26X20
IR22X28X17	IR22X28X17	JR22X28X17
IR22X28X20.5	IR22X28X20.5	JR22X28X20.5
—	IR22X28X23	—
IR22X28X30	IR22X28X30	JR22X28X30
IR25X29X20	IR25X29X20	JR25X29X20



INTERCHANGE

INNER RINGS

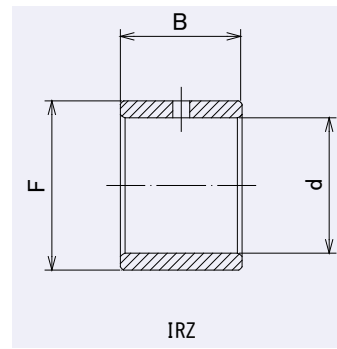
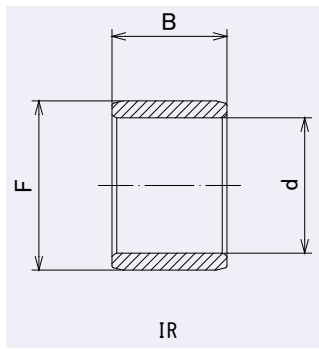

IR, IRZ

DIMENSION TABLE

INTERCHANGE TABLE

JNS NUMBER INNER RING	Mass (Approx.) g	Dimensions(mm)			JNS USABLE BEARING NUMBER		IKO
		d	F	B			LRT / IRT LRTZ
IR 252930	38	25	29	30	NK 29/30	—	LRT252930
IR 253015	24.5	25	30	15	—	—	—
IR 253015.5	25.5	25	30	15.5	—	—	IRT2515-1
IR 253016	28	25	30	16	RNAF 304216	—	LRT253016
IR 253017	28.5	25	30	17	RNA 4905	RNAF 304017	LRT253017
IRZ 253018	29.5	25	30	18	RNA 4905UU	—	LRTZ253018
IR 253020	33	25	30	20	—	—	—
IR 253020.5	34	25	30	20.5	—	—	LRT253020
IR 253023	38	25	30	23	RNA 5905	—	—
IR 253025.5	42.5	25	30	25.5	—	—	IRT2525-1
IR 253026	44.5	25	30	26	RNAFW 304026	—	LRT253016
IR 253026.5	44	25	30	26.5	—	—	IRT2526-1
IR 253030	49	25	30	30	RNA 6905	—	LRT253030
IR 253030.5	50.5	25	30	30.5	—	—	IRT2530-1
IRZ 253031	51	25	30	31	RNA 6905UU	—	LRTZ253031
IR 253032	54	25	30	32	RNAFW 304232	—	LRT253032
IR 253038.5	64	25	30	38.5	—	—	IRT2538-1
IR 283217	24.5	28	32	17	RNA 49/28	—	LRT283217
IR 283220	28.5	28	32	20	NK 32/20	—	LRT283220
IR 283220.5	29.5	28	32	20.5	—	—	IRT2820
IR 283223	34	28	32	23	RNA 59/28	—	—
IR 283230	43	28	32	30	RNA 69/28	NK 32/30	LRT283230
IR 283230.5	44	28	32	30.5	—	—	IRT2830
IR 303516	31.5	30	35	16	RNAF 354716	—	LRT303516
IR 303517	33.5	30	35	17	RNA 4906	RNAF 354517	LRT303517
IRZ 303518	35	30	35	18	RNA 4906UU	—	LRTZ303818
IR 303520	38.5	30	35	20	NK 35/20	—	LRT303520
IR 303520.5	40	30	35	20.5	—	—	IRT3020
IR 303523	44	30	35	23	RNA 5906	—	—
IR 303525.5	51	30	35	25.5	—	—	IRT3025
IR 303526	52	30	35	26	RNAFW 354526	—	LRT303526
IR 303530	59	30	35	30	RNA 6906	NK 35/30	LRT303530
IR 303530.5	60	30	35	30.5	—	—	IRT3030
IRZ 303531	61	30	35	31	RNA 6906UU	—	LRTZ303531
IR 303532	64	30	35	32	RNAFW 354732	—	LRT303532
IR 303820	65	30	38	20	—	—	—
IR 323720	43.5	32	37	20	NK 37/20	—	LRT323720



INTERCHANGE

INA	NTN	TORRINGTON(KOYO)
IR	IR	JR JRZ
IR25X29X30	IR25X29X30	JR25X29X30
—	—	—
—	—	—
IR25X30X16	IR25X30X16	JR25X30X16
IR25X30X17	IR25X30X17	JR25X30X17
IR25X30X18	IR25X30X18	JRZ25X30X18JS1
IR25X30X20	IR25X30X20	JR25X30X20
IR25X30X20.5	IR25X30X20.5	JR25X30X20.5
—	IR25X30X23	—
—	—	—
IR25X30X26	IR25X30X26	JR25X30X26
IR253026.5	—	JR25X30X26.5
IR25X30X30	IR25X30X30	JR25X30X30
—	—	—
—	—	—
IR25X30X32	IR25X30X32	JR25X30X32
IR25X30X38.5	—	JR25X30X38.5
IR28X32X17	IR28X32X17	JR28X32X17
IR28X32X20	IR28X32X20	JR28X32X20
—	—	—
—	IR28X32X23	—
IR28X32X30	IR28X32X30	JR28X32X30
—	—	—
IR30X35X16	IR30X35X16	JR30X35X16
IR30X35X17	IR30X35X17	JR30X35X17
IR30X35X18	IR30X35X18D	JRZ30X35X18JS1
IR30X35X20	IR30X35X20	JR30X35X20
IR30X35X20.5	IR30X35X20.5	JR30X35X20.5
—	IR30X35X23	—
—	—	—
IR30X35X26	IR30X35X26	JR30X35X26
IR30X35X30	IR30X35X30	JR30X35X30
—	—	—
IR30X35X31	—	—
IR30X35X32	IR30X35X32	JR30X35X32
IR30X38X20	IR30X38X20	—
IR32X37X20	IR32X37X20	JR32X37X20



INTERCHANGE

INNER RINGS

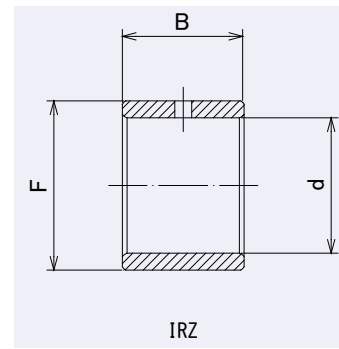
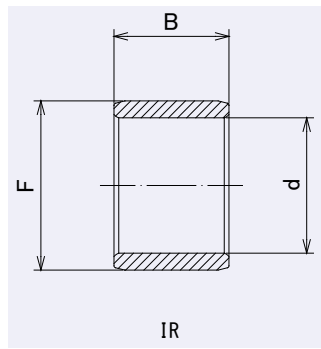

IR, IRZ

DIMENSION TABLE

INTERCHANGE TABLE

JNS NUMBER INNER RING	Mass (Approx.) g	Dimensions(mm)			JNS USABLE BEARING NUMBER		IKO
		d	F	B			LRT / IRT LRTZ
IR IRZ							
IR 323730	63	32	37	30	NK 37/30	—	LRT323730
IR 324020	69	32	40	20	RNA 49/32	—	LRT324020
IR 324027	92	32	40	27	RNA 59/32	—	—
IR 324036	123	32	40	36	RNA 69/32	—	LRT324036
IR 354017	39	35	40	17	RNAF 405017	—	LRT354017
IR 354020	46	35	40	20	NK 40/20	RNAF 405520	LRT354020
IR 354020.5	46.5	35	40	20.5	—	—	IRT3520
IR 354025.5	46	35	40	25.5	—	—	IRT3525
IR 354030	67	35	40	30	NK 40/30	—	LRT354030
IR 354034	78	35	40	34	RNAFW 405034	—	LRT354034
IR 354040	95	35	40	40	RNAFW 405540	—	LRT354040
IR 354220	65	35	42	20	RNA 4907	—	LRT354220
IRZ 354221	67	35	42	21	RNA 4907UU	—	LRTZ354221
IR 354227	80	35	42	27	RNA 5907	—	—
IR 354236	120	35	42	36	RNA 6907	—	LRT354236
IRZ 354237	120	35	42	37	RNA 6907UU	—	LRTZ354237
IR 384320	49.5	38	43	20	NK 43/20	—	LRT384320
IR 384330	72	38	43	30	NK 43/30	—	LRT384330
IR 404517	44.5	40	45	17	RNAF 455517	—	LRT404517
IR 404520	51	40	45	20	NK 45/20	RNAF 456220	LRT404520
IR 404520.5	52.5	40	45	20.5	—	—	IRT4020
IR 404525.5	65.5	40	45	25.5	—	—	IRT4025
IR 404530	77	40	45	30	NK 45/30	—	LRT404530
IR 404530.5	78.5	40	45	30.5	—	—	IRT4030
IR 404534	88	40	45	34	RNAFW 455534	—	LRT404534
IR 404540	105	40	45	40	RNAFW 456240	—	LRT404540
IR 404540.5	104	40	45	40.5	—	—	IRT4040
IR 404822	93	40	48	22	RNA 4908	—	LRT404822
IRZ 404823	95	40	48	23	RNA 4908UU	—	LRTZ404823
IR 404830	123	40	48	30	RNA 5908	—	—
IR 404840	165	40	48	40	RNA 6908	—	LRT404840
IRZ 404841	170	40	48	41	RNA 6908UU	—	LRTZ404841
IR 424720	54	42	47	20	NK 47/20	—	LRT424720
IR 424730	81	42	47	30	NK 47/30	—	LRT424730
IR 455020	58	45	50	20	RNAF 506220	—	LRT455020
IR 455025	71	45	50	25	NK 50/25	—	LRT455025
IR 455025.5	73	45	50	25.5	—	—	IRT4525



INTERCHANGE

INA	NTN	TORRINGTON(KOYO)
IR	IR	JR JRZ
IR32X37X30	IR32X37X30	JR32X37X30
IR32X40X20	IR32X40X20	JR32X40X20
—	IR32X40X27	—
IR32X40X36	IR32X40X36	JR32X40X36
IR35X40X17	IR35X40X17	JR35X40X17
IR35X40X20	IR35X40X20	JR35X40X20
IR35X40X20.5	IR35X40X20.5	JR35X40X20.5
—	—	—
IR35X40X30	IR35X40X30	JR35X40X30
IR35X40X34	IR35X40X34	JR35X40X34
IR35X40X40	IR35X40X40	JR35X40X40
IR35X42X20	IR35X42X20	JR35X42X20
IR35X42X21	—	—
—	IR35X42X27	—
IR35X42X36	IR35X42X36	JR35X42X36
—	—	—
IR38X43X20	IR38X43X20	JR38X43X20
IR38X43X30	—	—
IR40X45X17	IR40X45X17	JR40X45X17
IR40X45X20	IR40X45X20	JR40X45X20
IR40X45X20.5	IR40X45X20.5	JR40X45X20.5
—	—	—
IR40X45X30	IR40X45X30	JR40X45X30
—	—	—
IR40X45X34	IR40X45X34	JR40X45X34
IR40X45X40	IR40X45X40	JR40X45X40
—	—	—
IR40X48X22	IR40X48X22	JR40X48X22
IR40X48X23	—	—
—	IR40X48X30	—
IR40X48X40	IR40X48X40	JR40X48X40
—	—	—
IR42X47X20	IR42X47X20	JR42X47X20
IR42X47X30	IR42X47X30	JR42X47X30
IR45X50X20	IR45X50X20	JR45X50X20
IR45X50X25	IR45X50X25	JR45X50X25
IR45X50X25.5	IR45X50X25.5	JR45X50X25.5



INTERCHANGE

INNER RINGS

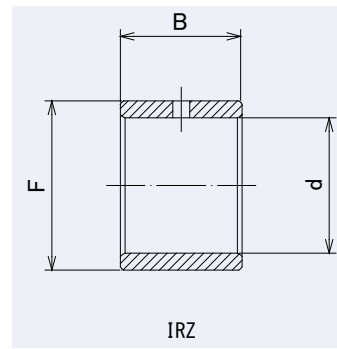
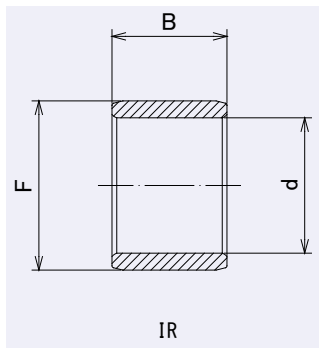

IR, IRZ

DIMENSION TABLE

INTERCHANGE TABLE

JNS NUMBER INNER RING	Mass (Approx.)	Dimensions(mm)			JNS USABLE BEARING NUMBER		IKO
		IR	IRZ	g			d
IR 455030.5	87.5	45	50	30.5	—	—	IRT4530
IR 455035	95	45	50	35	NK 50/35	—	LRT455035
IR 455040	115	45	50	40	RNAFW 506240	—	LRT455040
IR 455222	88	45	52	22	RNA 4909	—	LRT455222
IRZ 455223	93	45	52	23	RNA 4909UU	—	LRTZ455223
IR 455230	123	45	52	30	RNA 5909	—	—
IR 455240	165	45	52	40	RNA 6909	—	LRT455240
IRZ 455241	170	45	52	41	RNA 6909UU	—	LRTZ455241
IR 455520	120	45	55	20	RNAF 557220	—	LRT455520
IR 455522	130	45	55	22	—	—	—
IR 455540	245	45	55	40	RNAFW 557240	—	LRT455540
IR 505520	63	50	55	20	RNAF 556820	—	LRT505520
IR 505525	77	50	55	25	NK 55/25	—	LRT505525
IR 505535	110	50	55	35	NK 55/35	—	LRT505535
IR 505540	130	50	55	40	RNAFW 556840	—	LRT505540
IR 505822	116	50	58	22	RNA 4910	—	LRT505822
IRZ 505823	118	50	58	23	RNA 4910UU	—	LRTZ505823
IR 505830	159	50	58	30	RNA 5910	—	—
IR 505840	210	50	58	40	RNA 6910	—	LRT505840
IRZ 505841	215	50	58	41	RNA 6910UU	—	LRTZ505841
IR 506020	135	50	60	20	RNAF 607820	—	LRT506020
IR 506025	163	50	60	25	—	—	—
IR 506040	265	50	60	40	RNAFW 607840	—	LRT506040
IR 556025	88	55	60	25	NK 60/25	—	LRT556025
IR 556035	120	55	60	35	NK 60/35	—	LRT556035
IR 556325	145	55	63	25	RNA 4911	—	LRT556325
IR 556334	192	55	63	34	RNA 5911	—	—
IR 556345	255	55	63	45	RNA 6911	—	LRT556345
IR 556530	220	55	65	30	RNAF 658530	—	LRT556530
IR 556560	435	55	65	60	RNAFW 658560	—	LRT556560
IR 606825	150	60	68	25	RNA 4912	NK 68/25	LRT606825
IR 606834	206	60	68	34	RNA 5912	—	—
IR 606835	210	60	68	35	NK 68/35	—	LRT606835
IR 606845	275	60	68	45	RNA 6912	—	LRT606845
IR 607025	195	60	70	25	—	—	—
IR 607030	240	60	70	30	RNAF 709030	—	LRT607030
IR 607060	480	60	70	60	RNAFW 709060	—	LRT607060



INTERCHANGE

INA	NTN	TORRINGTON(KOYO)
IR	IR	JR JRZ
—	—	—
IR45X50X35	IR45X50X35	JR45X50X35
IR45X50X40	IR45X50X40	JR45X50X40
IR45X52X22	IR45X52X22	JR45X52X22
IR45X52X23	IR45X52X23D	JRZ45X52X23JS1
—	IR45X52X30	—
IR45X52X40	IR45X52X40	JR45X52X40
—	—	—
IR45X55X20	IR45X55X20	JR45X55X20
IR45X55X22	IR45X55X22	JR45X55X22
IR45X55X40	IR45X55X40	JR45X55X40
IR50X55X20	IR50X55X20	JR50X55X20
IR50X55X25	IR50X55X25	JR50X55X25
IR50X55X35	IR50X55X35	JR50X55X35
IR50X55X40	IR50X55X40	JR50X55X40
IR50X58X22	IR50X58X22	JR50X58X22
IR50X58X23	IR50X58X23D	JRZ50X58X23JS1
—	IR50X58X30	—
IR50X58X40	IR50X58X40	JR50X58X40
—	—	—
IR50X60X20	IR50X60X20	JR50X60X20
IR50X60X25	IR50X60X25	JR50X60X25
IR50X60X40	IR50X60X40	JR50X60X40
IR55X60X25	IR55X60X25	JR55X60X25
IR55X60X35	IR55X60X35	JR55X60X35
IR55X63X25	IR55X63X25	JR55X63X25
—	IR55X63X34	—
IR55X63X45	IR55X63X45	JR55X63X45
IR55X65X30	IR55X65X30	JR55X65X30
IR55X65X60	IR55X65X60	JR55X65X60
IR60X68X25	IR60X68X25	JR60X68X25
—	IR60X68X34	—
IR60X68X35	IR60X68X35	JR60X68X35
IR60X68X45	IR60X68X45	JR60X68X45
IR60X70X25	IR60X70X25	JR60X70X25
IR60X70X30	IR60X70X30	JR60X70X30
IR60X70X60	IR60X70X60	JR60X70X60



INTERCHANGE

INNER RINGS

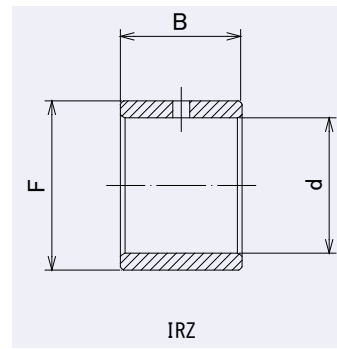
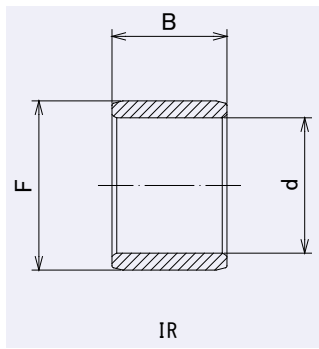

IR, IRZ

DIMENSION TABLE

INTERCHANGE TABLE

JNS NUMBER INNER RING	Mass (Approx.) g	Dimensions(mm)			JNS USABLE BEARING NUMBER		IKO
		d	F	B			LRT / IRT LRTZ
IR 657225	145	65	72	25	RNA 4913	—	LRT657225
IR 657234	193	65	72	34	RNA 5913	—	—
IR 657245	255	65	72	45	RNA 6913	—	LRT657245
IR 657335	235	65	73	35	NK 73/35	—	LRT657335
IR 657530	260	65	75	30	RNAF 759530	—	LRT657530
IR 657560	520	65	75	60	RNAFW 759560	—	LRT657560
IR 708025	225	70	80	25	NK 80/25	—	LRT708025
IR 708030	275	70	80	30	RNA 4914	RNAF 8010030	LRT708030
IR 708035	310	70	80	35	NK 80/35	—	LRT708035
IR 708040	358	70	80	40	RNA 5914	—	—
IR 708054	490	70	80	54	RNA 6914	—	LRT708054
IR 708060	560	70	80	60	RNAFW 8010060	—	LRT708060
IR 758525	240	75	85	25	NK 85/25	—	LRT758525
IR 758530	290	75	85	30	RNA 4915	RNAF 8510530	LRT758530
IR 758535	335	75	85	35	NK 85/35	—	LRT758535
IR 758540	385	75	85	40	RNA 5915	—	—
IR 758554	520	75	85	54	RNA 6915	—	LRT758554
IR 809025	255	80	90	25	NK 90/25	—	LRT809025
IR 809030	310	80	90	30	RNA 4916	RNAF 9011030	LRT809030
IR 809035	355	80	90	35	NK 90/35	—	LRT809035
IR 809040	408	80	90	40	RNA 5916	—	—
IR 809054	550	80	90	54	RNA 6916	—	LRT809054
IR 859526	280	85	95	26	NK 95/26	—	LRT859526
IR 859530	330	85	95	30	RNAF 9511530	—	LRT859530
IR 859536	390	85	95	36	NK 95/36	—	LRT859536
IR 8510035	575	85	100	35	RNA 4917	—	LRT8510035
IR 8510046	760	85	100	46	RNA 5917	—	—
IR 8510063	1 040	85	100	63	RNA 6917	—	LRT8510063
IR 9010026	295	90	100	26	NK 100/26	—	LRT9010026
IR 9010030	355	90	100	30	RNAF 10012030	—	LRT9010030
IR 9010036	415	90	100	36	NK 100/36	—	LRT9010036
IR 9010535	610	90	105	35	RNA 4918	—	LRT9010535
IR 9010546	800	90	105	46	RNA 5918	—	—
IR 9010563	1 100	90	105	63	RNA 6918	—	LRT9010563
IR 9510526	315	95	105	26	NK 105/26	—	LRT9510526
IR 9510536	430	95	105	36	NK 105/36	—	LRT9510536
IR 9511035	650	95	110	35	RNA 4919	—	LRT9511035



INTERCHANGE

INA	NTN	TORRINGTON(KOYO)
IR	IR	JR JRZ
IR65X72X25	IR65X72X25	JR65X72X25
—	IR65X72X34	—
IR65X72X45	IR65X72X45	JR65X72X45
IR65X73X35	IR65X73X35	JR65X73X35
IR65X75X30	IR65X75X30	JR65X75X30
IR65X75X60	IR65X75X60	JR65X75X60
IR70X80X25	IR70X80X25	JR70X80X25
IR70X80X30	IR70X80X30	JR70X80X30
IR70X80X35	IR70X80X35	JR70X80X35
—	IR70X80X40	—
IR70X80X54	IR70X80X54	JR70X80X54
IR70X80X60	IR70X80X60	JR70X80X60
IR75X85X25	IR75X85X25	JR75X85X25
IR75X85X30	IR75X85X30	JR75X85X30
IR75X85X35	IR75X85X35	JR75X85X35
—	IR75X85X40	—
IR75X85X54	IR75X85X54	JR75X85X54
IR80X90X25	IR80X90X25	JR80X90X25
IR80X90X30	IR80X90X30	JR80X90X30
IR80X90X35	IR80X90X35	JR80X90X35
—	IR80X90X40	—
IR80X90X54	IR80X90X54	JR80X90X54
IR85X95X26	IR85X95X26	JR85X95X26
IR85X95X30	IR85X95X30	JR85X95X30
IR85X95X36	IR85X95X36	JR85X95X36
IR85X100X35	IR85X100X35	JR85X100X35
—	IR85X100X46	—
IR85X100X63	IR85X100X63	JR85X100X63
IR90X100X26	IR90X100X26	JR90X100X26
IR90X100X30	IR90X100X30	JR90X100X30
IR90X100X36	IR90X100X36	JR90X100X36
IR90X105X35	IR90X105X35	JR90X105X35
—	IR90X105X46	—
IR90X105X63	IR90X105X63	JR90X105X63
IR95X105X26	IR95X105X26	JR95X105X26
IR95X105X36	IR95X105X36	JR95X105X36
IR95X110X35	IR95X110X35	JR95X110X35



INTERCHANGE

INNER RINGS

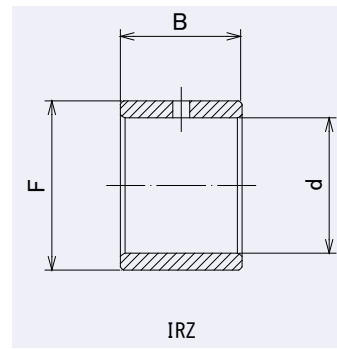
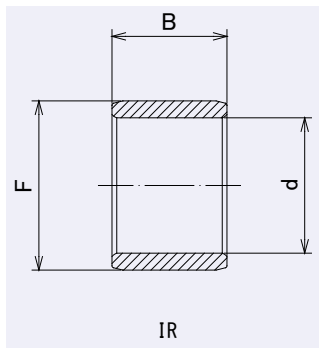

IR, IRZ

DIMENSION TABLE

INTERCHANGE TABLE

JNS NUMBER INNER RING	Mass (Approx.)	Dimensions(mm)			JNS USABLE BEARING NUMBER		IKO	
		IR	IRZ	g			d	
IR 9511046	850	95	110	46	RNA 5919	—	—	
IR 9511063	1 160	95	110	63	RNA 6919	—	LRT9511063	
IR 10011030	380	100	110	30	NK 110/30	—	LRT10011030	
IR 10011040	500	100	110	40	NK 110/40	—	LRT10011040	
IR 10011540	700	100	115	40	RNA 4920	—	LRT10011540	
IR 11012030	410	110	120	30	RNA 4822	—	LRT11012030	
IR 11012540	840	110	125	40	RNA 4922	—	LRT11012540	
IR 12013030	450	120	130	30	RNA 4824	—	LRT12013030	
IR 12013545	1 030	120	135	45	RNA 4924	—	LRT12013545	
IR 13014535	860	130	145	35	RNA 4826	—	LRT13014535	
IR 13015050	1 670	130	150	50	RNA 4926	—	LRT13015050	
IR 14015535	930	140	155	35	RNA 4828	—	LRT14015535	
IR 14016050	1 790	140	160	50	RNA 4928	—	LRT14016050	
IR 15016540	1 130	150	165	40	RNA 4830	—	LRT15016540	
IR 16017540	1 200	160	175	40	RNA 4832	—	LRT16017540	



INTERCHANGE

INA	NTN	TORRINGTON(KOYO)
IR	IR	JR JRZ
—	IR95X110X46	—
IR95X110X63	IR95X110X63	JR95X110X63
IR100X110X30	IR100X110X30	JR100X110X30
IR100X110X40	IR100X110X40	JR100X110X40
IR100X115X40	IR100X115X40	JR100X115X40
IR110X120X30	IR110X120X30	JR110X120X30
IR110X125X40	IR110X125X40	JR110X125X40
IR120X130X30	IR120X130X30	JR120X130X30
IR120X135X45	IR120X135X45	JR120X135X45
IR130X145X35	IR130X145X35	JR130X145X35
IR130X150X50	IR130X150X50	JR130X150X50
IR140X155X35	IR140X155X35	JR140X155X35
IR140X160X50	IR140X160X50	JR140X160X50
IR150X165X40	IR150X165X40	JR150X165X40
IR160X175X40	IR160X175X40	JR160X175X40



CAM FOLLOWERS

MINIATURE TYPE HEXAGON SOCKET ON STUD HEAD

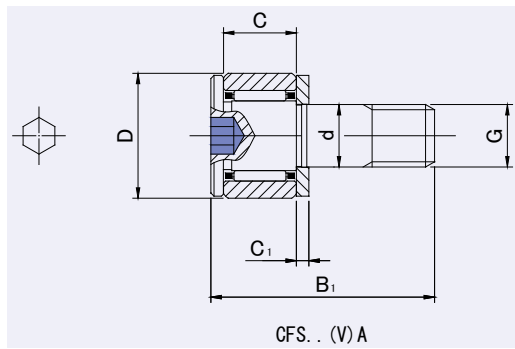

CFS..A

DIMENSION TABLE

JNS NUMBER CYLINDRICAL OUTER RING	Mass (Approx.)	Dimensions(mm)						Basic dynamic load rating	Basic static load rating	
		d	D	C	G	B1	C1			
CFS	g	d	D	C	G	B1	C1	Cr N	Cor N	
CFS 2.5A	1	2.5	5	3	M2.5×0.45	9.5	0.7	410	335	
CFS 2.5VA	1	2.5	5	3	M2.5×0.45	9.5	0.7	1 000	1 080	
CFS 3A	2	3	6	4	M3×0.5	11.5	0.7	630	610	
CFS 3VA	2	3	6	4	M3×0.5	11.5	0.7	1 370	1 770	
CFS 4A	4	4	8	5	M4×0.7	15	1	1 080	1 080	
CFS 4VA	4	4	8	5	M4×0.7	15	1	2 350	3 040	
CFS 5A	7	5	10	6	M5×0.8	18	1	1 570	1 860	
CFS 5VA	7	5	10	6	M5×0.8	18	1	3 140	4 710	
CFS 6A	13	6	12	7	M6×1	21.5	1.2	2 060	2 160	
CFS 6VA	13	6	12	7	M6×1	21.5	1.2	4 610	6 270	



INTERCHANGE

INTERCHANGE TABLE

INA	IKO	NTN	MCGILL
CYLINDRICAL OUTER RING	CYLINDRICAL OUTER RING	CYLINDRICAL OUTER RING	CYLINDRICAL OUTER RING
—	CFS	KRM	—
—	CFS2.5	KRM5XT2H/3A	—
—	CFS2.5V	KRMV5XT2H/3A	—
—	CFS3	KRM6XT2H/3A	—
—	CFS3V	KRMV6XT2H/3A	—
—	CFS4	KRM8XT2H/3A	—
—	CFS4V	KRMV8XT2H/3A	—
—	CFS5	KRM10XT2H/3A	—
—	CFS5V	KRMV10XT2H/3A	—
—	CFS6	KRM12XT2H/3A	—
—	CFS6V	KRMV12XT2H/3A	—

CAM FOLLOWERS

EASY MOUNTING TYPE
SCREWDRIVER SLOT HEAD

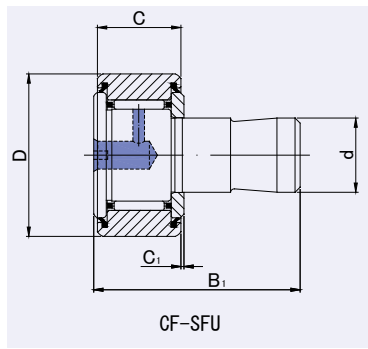

CF-SFU, R

DIMENSION TABLE

JNS NUMBER CYLINDRICAL OUTER RING	JNS NUMBER CROWNED OUTER RING	Mass (Approx.) g	Dimensions(mm)					Basic dynamic load rating Cr N	Basic static load rating Cor N
			d	D	C	B1	C1		
CF-SFU	CF-SFU..R		d	D	C	B1	C1	Cr N	Cor N
CF-SFU- 6	CF-SFU- 6R	19	6	16	11	32	0.6	3 630	3 630
CF-SFU- 6V	CF-SFU- 6VR	19	6	16	11	32	0.6	6 960	8 530
CF-SFU- 8	CF-SFU- 8R	28.5	8	19	11	32	0.6	4 310	4 710
CF-SFU- 8V	CF-SFU- 8VR	28.5	8	19	11	32	0.6	8 130	11 170
CF-SFU-10	CF-SFU-10R	43	10	22	12	33	0.6	5 390	6 860
CF-SFU-10V	CF-SFU-10VR	43	10	22	12	33	0.6	9 510	14 500
CF-SFU-10-1	CF-SFU-10-1R	58.5	10	26	12	33	0.6	5 390	6 860
CF-SFU-10-1V	CF-SFU-10-1VR	58.5	10	26	12	33	0.6	9 510	14 500
CF-SFU-12	CF-SFU-12R	93	12	30	14	35	0.6	7 940	9 800
CF-SFU-12V	CF-SFU-12VR	93	12	30	14	35	0.6	13 430	19 700
CF-SFU-12-1	CF-SFU-12-1R	103	12	32	14	35	0.6	7 940	9 800
CF-SFU-12-1V	CF-SFU-12-1VR	103	12	32	14	35	0.6	13 430	19 700
CF-SFU-16	CF-SFU-16R	163.5	16	35	18	44.5	0.8	12 050	18 330
CF-SFU-16V	CF-SFU-16VR	163.5	16	35	18	44.5	0.8	20 680	37 630
CF-SFU-18	CF-SFU-18R	235	18	40	20	46.5	0.8	14 700	25 200
CF-SFU-18V	CF-SFU-18VR	235	18	40	20	46.5	0.8	25 280	51 350
CF-SFU-20	CF-SFU-20R	436	20	52	24	50.5	0.8	20 680	34 600
CF-SFU-20V	CF-SFU-20VR	436	20	52	24	50.5	0.8	33 120	64 480
CF-SFU-20-1	CF-SFU-20-1R	361	20	47	24	50.5	0.8	20 680	34 600
CF-SFU-20-1V	CF-SFU-20-1VR	361	20	47	24	50.5	0.8	33 120	64 480



INTERCHANGE

INTERCHANGE TABLE

INA		IKO		NTN		MCGILL	
CYLINDRICAL OUTER RING	CROWNED OUTER RING	CYLINDRICAL OUTER RING	CROWNED OUTER RING	CYLINDRICAL OUTER RING	CROWNED OUTER RING	CYLINDRICAL OUTER RING	CROWNED OUTER RING
—	—	CF-SFU	—	KRX	KRX	—	—
—	—	CF-SFU- 6	—	KRX6X16X32-2	KRX6X16X32-4	—	—
—	—	—	—	—	—	—	—
—	—	CF-SFU- 8	—	KRX8X19X32-7	KRX8X19X32-9	—	—
—	—	—	—	—	—	—	—
—	—	CF-SFU-10	—	KRX10X22X33-1	KRX10X22X33-3	—	—
—	—	—	—	—	—	—	—
—	—	CF-SFU-10-1	—	KRX10X26X33-2	KRX10X26X33-4	—	—
—	—	—	—	—	—	—	—
—	—	CF-SFU-12	—	KRX12X30X35	KRX12X30X35-3	—	—
—	—	—	—	—	—	—	—
—	—	CF-SFU-12-1	—	KRX12X32X35-1	KRX12X32X35-3	—	—
—	—	—	—	—	—	—	—
—	—	CF-SFU-16	—	KRX16X35X44.5-3	KRX16X35X44.5-1	—	—
—	—	—	—	—	—	—	—
—	—	CF-SFU-18	—	KRX18X40X46.5-4	KRX18X40X46.5-6	—	—
—	—	—	—	—	—	—	—
—	—	CF-SFU-20	—	KRX20X47X50.5-3	KRX20X47X50.5-1	—	—
—	—	—	—	—	—	—	—
—	—	CF-SFU-20-1	—	KRX20X52X50.5-1	KRX20X52X50.5-3	—	—
—	—	—	—	—	—	—	—



INTERCHANGE

CAM FOLLOWERS

HEXAGON SOCKET ON STUD HEAD

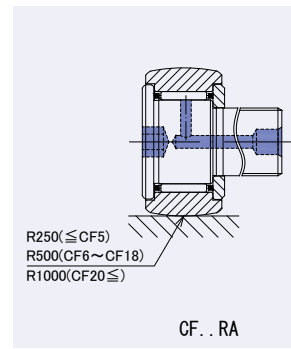
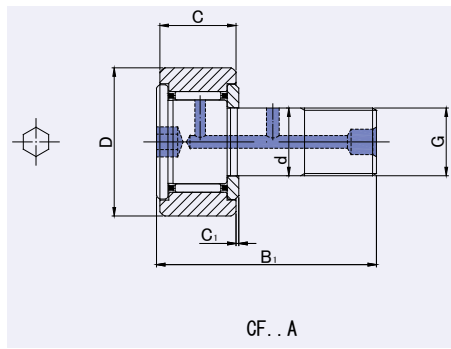

CF..A, RA

DIMENSION TABLE

JNS NUMBER CYLINDRICAL OUTER RING	JNS NUMBER CROWNED OUTER RING	Mass (Approx.) g	Dimensions(mm)						Basic dynamic load rating Cr N	Basic static load rating Cor N
			CF..A	CF..RA	d	D	C	G		
CF 3A	CF 3RA	4.5	3	10	7	M3×0.5	17	0.5	1 470	1 180
CF 3VA	CF 3RVA	4.5	3	10	7	M3×0.5	17	0.5	2 800	2 500
CF 4A	CF 4RA	7.5	4	12	8	M4×0.7	20	0.5	2 060	2 050
CF 4VA	CF 4RVA	7.5	4	12	8	M4×0.7	20	0.5	4 000	4 300
CF 5A	CF 5RA	10.5	5	13	9	M5×0.8	23	0.5	3 140	2 770
CF 5VA	CF 5VRA	10.5	5	13	9	M5×0.8	23	0.5	5 100	5 500
CF 6A	CF 6RA	18.5	6	16	11	M6×1	28	0.6	3 630	3 630
CF 6VA	CF 6VRA	18.5	6	16	11	M6×1	28	0.6	6 960	8 530
CF 8A	CF 8RA	28.5	8	19	11	M8×1.25	32	0.6	4 310	4 710
CF 8VA	CF 8VRA	28.5	8	19	11	M8×1.25	32	0.6	8 130	11 170
CF10A	CF10RA	45	10	22	12	M10×1.25	36	0.6	5 390	6 860
CF10VA	CF10VRA	45	10	22	12	M10×1.25	36	0.6	9 510	14 500
CF10AK	CF10RAK	45	10	22	12	M10×1	36	0.6	5 390	6 860
CF10VAK	CF10VRAK	45	10	22	12	M10×1	36	0.6	9 510	14 500
CF10-1A	CF10-1RA	60	10	26	12	M10×1.25	36	0.6	5 390	6 860
CF10-1VA	CF10-1VRA	60	10	26	12	M10×1.25	36	0.6	9 510	14 500
CF10-1AK	CF10-1RAK	60	10	26	12	M10×1	36	0.6	5 390	6 860
CF10-1VAK	CF10-1VRAK	60	10	26	12	M10×1	36	0.6	9 510	14 500
CF12A	CF12RA	95	12	30	14	M12×1.5	40	0.6	7 940	9 800
CF12VA	CF12VRA	95	12	30	14	M12×1.5	40	0.6	13 430	19 700
CF12-1A	CF12-1RA	105	12	32	14	M12×1.5	40	0.6	7 940	9 800
CF12-1VA	CF12-1VRA	105	12	32	14	M12×1.5	40	0.6	13 430	19 700
CF16A	CF16RA	170	16	35	18	M16×1.5	52	0.8	12 050	18 330
CF16VA	CF16VRA	170	16	35	18	M16×1.5	52	0.8	20 680	37 630
CF18A	CF18RA	250	18	40	20	M18×1.5	58	0.8	14 700	25 200
CF18VA	CF18VRA	250	18	40	20	M18×1.5	58	0.8	25 280	51 350
CF20A	CF20RA	460	20	52	24	M20×1.5	66	0.8	20 680	34 600
CF20VA	CF20VRA	460	20	52	24	M20×1.5	66	0.8	33 120	64 480
CF20-1A	CF20-1RA	385	20	47	24	M20×1.5	66	0.8	20 680	34 600
CF20-1VA	CF20-1VRA	385	20	47	24	M20×1.5	66	0.8	33 120	64 480
CF24A	CF24RA	815	24	62	29	M24×1.5	80	0.8	30 480	52 630
CF24VA	CF24VRA	815	24	62	29	M24×1.5	80	0.8	46 550	92 020
CF24-1A	CF24-1RA	1 140	24	72	29	M24×1.5	80	0.8	30 480	52 630
CF24-1VA	CF24-1VRA	1 140	24	72	29	M24×1.5	80	0.8	46 550	92 020

Stud diameter (d) 3 to 10mm : No grease refilling hole is provided (except "K" type)



INTERCHANGE

INTERCHANGE TABLE

INA		NTN		IKO		MCGILL	
CYLINDRICAL OUTER RING	CROWNED OUTER RING	CYLINDRICAL OUTER RING	CROWNED OUTER RING	CYLINDRICAL OUTER RING	CROWNED OUTER RING	CYLINDRICAL OUTER RING	CROWNED OUTER RING
KR-XSK	KR-SK	KR-XH	KR-H	CF-B	CF-BR	MCFR-BX	MCFR-B
—	—	KR10T2XH/3AS	KR10T2H/3AS	CF3B	CF3BR	—	—
—	—	KRV10T2XH/3AS	KRV10T2H/3AS	—	—	—	—
—	—	KR12T2XH/3AS	KR12T2H/3AS	CF4B	CF4BR	—	—
—	—	KRV12T2XH/3AS	KRV12T2H/3AS	—	—	—	—
—	—	KR13T2XH/3AS	KR13T2H/3AS	CF5B	CF5BR	MCFR-13BX	MCFR-13B
—	—	KRV13T2XH/3AS	KRV13T2H/3AS	—	—	MCF-13BX	MCF-13B
KR16X-SK	KR16-SK	KR16XH	KR16H	CF6B	CF6BR	MCFR-16BX	MCFR-16B
KRV16X-SK	KRV16-SK	KRV16XH/3AS	KRV16H/3AS	CF6VB	CF6VBR	MCF-16BX	MCF-16B
KR19X-SK	KR19-SK	KR19XH	KR19H	CF8B	CF8BR	MCFR-19BX	MCFR-19B
KRV19X-SK	KRV19-SK	KRV19XH/3AS	KRV19H/3AS	CF8VB	CF8VBR	MCF-19BX	MCF-19B
—	—	KR22XH	KR22H	CF10B	CF10BR	MCFR-22BXA	MCFR-22BA
—	—	KRV22XH/3AS	KRV22H/3AS	CF10VB	CF10VBR	MCF-22BXA	MCF-22BA
KR22X-SK	KR22-SK	—	—	CF10BM	CF10BRM	MCFR-22BX	MCFR-22B
KRV22X-SK	KRV22-SK	—	—	CF10VBM	CF10VBRM	MCF-22BX	MCF-22B
—	—	KR26XH	KR26H	CF10-1B	CF10-1BR	MCFR-26BXA	MCFR-26BA
—	—	KRV26XH/3AS	KRV26H/3AS	CF10-1VB	CF10-1VBR	MCF-26BXA	MCF-26BA
KR26X-SK	KR26-SK	—	—	CF10-1BM	CF10-1BRM	MCFR-26BX	MCFR-26B
KRV26X-SK	KRV26-SK	—	—	CF10-1VBM	CF10-1VBRM	MCF-26BX	MCF-26B
KR30X-SK	KR30-SK	KR30XH	KR30H	CF12B	CF12BR	MCFR-30BX	MCFR-30B
KRV30X-SK	KRV30-SK	KRV30XH/3AS	KRV30H/3AS	CF12VB	CF12VBR	MCF-30BX	MCF-30B
KR32X-SK	KR32-SK	KR32XH	KR32H	CF12-1B	CF12-1BR	MCFR-32BX	MCFR-32B
KRV32X-SK	KRV32-SK	KRV32XH/3AS	KRV32H/3AS	CF12-1VB	CF12-1VBR	MCF-32BX	MCF-32B
KR35X-SK	KR35-SK	KR35XH	KR35H	CF16B	CF16BR	MCFR-35BX	MCFR-35B
KRV35X-SK	KRV35-SK	KRV35XH/3AS	KRV35H/3AS	CF16VB	CF16VBR	MCF-35BX	MCF-35B
KR40X-SK	KR40-SK	KR40XH	KR40H	CF18B	CF18BR	MCFR-40BXA	MCFR-40BA
KRV40X-SK	KRV40-SK	KRV40XH/3AS	KRV40H/3AS	CF18VB	CF18VBR	MCF-40BXA	MCF-40BA
KR52X-SK	KR52-SK	KR52XH	KR52H	CF20B	CF20BR	MCFR-52BXA	MCFR-52BA
KRV52X-SK	KRV52-SK	KRV52XH/3AS	KRV52H/3AS	CF20VB	CF20VBR	MCF-52BXA	MCF-52BA
KR47X-SK	KR47-SK	KR47XH	KR47H	CF20-1B	CF20-1BR	MCFR-47BXA	MCFR-47BA
KRV47X-SK	KRV47-SK	KRV47XH/3AS	KRV47H/3AS	CF20-1VB	CF20-1VBR	MCF-47BXA	MCF-47BA
KR62X-SK	KR62-SK	KR62XH	KR62H	CF24B	CF24BR	MCFR-62BXA	MCFR-62BA
KRV62X-SK	KRV62-SK	KRV62XH/3AS	KRV62H/3AS	CF24VB	CF24VBR	MCF-62BXA	MCF-62BA
KR72X-SK	KR72-SK	KR72XH	KR72H	CF24-1B	CF24-1BR	MCFR-72BXA	MCFR-72BA
KRV72X-SK	KRV72-SK	KRV72XH/3AS	KRV72H/3AS	CF24-1VB	CF24-1VBR	MCF-72BXA	MCF-72BA



INTERCHANGE

CAM FOLLOWERS

HEXAGON SOCKET ON STUD HEAD

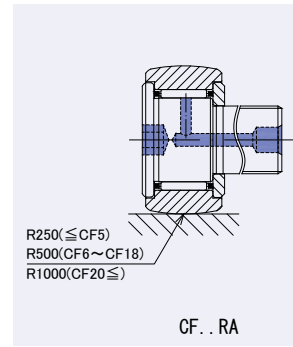
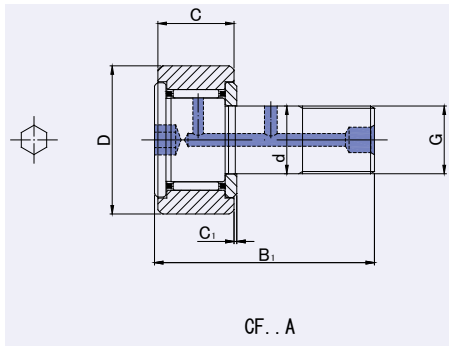

CF..A, RA

DIMENSION TABLE

JNS NUMBER CYLINDRICAL OUTER RING	JNS NUMBER CROWNED OUTER RING	Mass (Approx.) g	Dimensions(mm)						Basic dynamic load rating Cr N	Basic static load rating Cor N	
			CF..A	CF..RA	d	D	C	G			B1
CF30A	CF30RA	1 870		30	80	35	M30×1.5	100	1	45 370	85 060
CF30VA	CF30VRA	1 870		30	80	35	M30×1.5	100	1	67 620	144 060
CF30-1A	CF30-1RA	2 030		30	85	35	M30×1.5	100	1	45 370	85 060
CF30-1VA	CF30-1VRA	2 030		30	85	35	M30×1.5	100	1	67 620	144 060
CF30-2A	CF30-2RA	2 220		30	90	35	M30×1.5	100	1	45 370	85 060
CF30-2VA	CF30-2VRA	2 220		30	90	35	M30×1.5	100	1	67 620	144 060

Stud diameter (d) 3 to 10mm : No grease refilling hole is provided (except "K" type)



INTERCHANGE

INTERCHANGE TABLE

INA		NTN		IKO		MCGILL	
CYLINDRICAL OUTER RING	CROWNED OUTER RING	CYLINDRICAL OUTER RING	CROWNED OUTER RING	CYLINDRICAL OUTER RING	CROWNED OUTER RING	CYLINDRICAL OUTER RING	CROWNED OUTER RING
KR-XSK	KR-SK	KR-XH	KR-H	CF-B	CF-BR	MCFR-BX	MCFR-B
KR80X-SK	KR80-SK	KR80XH	KR80H	CF30B	CF30BR	MCFR-80BX	MCFR-80B
KRV80X-SK	KRV80-SK	KRV80XH/3AS	KRV80H/3AS	CF30VB	CF30VBR	MCF-80BX	MCF-80B
KR85X-SK	KR85-SK	—	—	CF30-1B	CF30-1BR	MCFR-85BX	MCFR-85B
KRV85X-SK	KRV85-SK	—	—	CF30-1VB	CF30-1VBR	MCF-85BX	MCF-85B
KR90X-SK	KR90-SK	KR90XH	KR90H	CF30-2B	CF30-2BR	MCFR-90BX	MCFR-90B
KRV90X-SK	KRV90-SK	KRV90XH/3AS	KRV90H/3AS	CF30-2VB	CF30-2VBR	MCF-90BX	MCF-90B



INTERCHANGE

CAM FOLLOWERS

HEXAGON SOCKET ON STUD HEAD

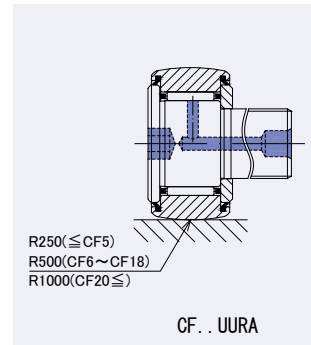
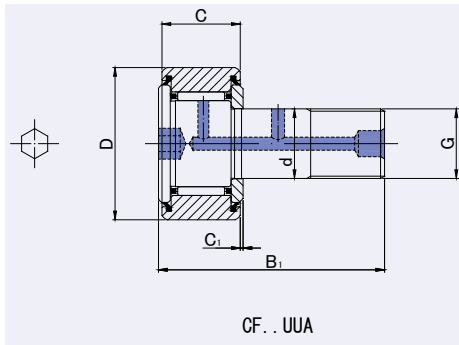

CF..UUA, UURA

DIMENSION TABLE

JNS NUMBER CYLINDRICAL OUTER RING	JNS NUMBER CROWNED OUTER RING	Mass (Approx.) g	Dimensions(mm)						Basic dynamic load rating Cr N	Basic static load rating Cor N
			CF..UUA	CF..UURA	d	D	C	G		
CF 3UUA	CF 3UURA	4.5	3	10	7	M3×0.5	17	0.5	1 470	1 180
CF 3VUUA	CF 3VUURA	4.5	3	10	7	M3×0.5	17	0.5	2 800	2 500
CF 4UUA	CF 4UURA	7.5	4	12	8	M4×0.7	20	0.5	2 060	2 050
CF 4VUUA	CF 4VUURA	7.5	4	12	8	M4×0.7	20	0.5	4 000	4 300
CF 5UUA	CF 5UURA	10.5	5	13	9	M5×0.8	23	0.5	3 140	2 770
CF 5VUUA	CF 5VUURA	10.5	5	13	9	M5×0.8	23	0.5	5 100	5 500
CF 6UUA	CF 6UURA	18.5	6	16	11	M6×1	28	0.6	3 630	3 630
CF 6VUUA	CF 6VUURA	18.5	6	16	11	M6×1	28	0.6	6 960	8 530
CF 8UUA	CF 8UURA	28.5	8	19	11	M8×1.25	32	0.6	4 310	4 710
CF 8VUUA	CF 8VUURA	28.5	8	19	11	M8×1.25	32	0.6	8 130	11 170
CF10UUA	CF10UURA	45	10	22	12	M10×1.25	36	0.6	5 390	6 860
CF10VUUA	CF10VUURA	45	10	22	12	M10×1.25	36	0.6	9 510	14 500
CF10UUA-K	CF10UURA-K	45	10	22	12	M10×1	36	0.6	5 390	6 860
CF10VUUA-K	CF10VUURA-K	45	10	22	12	M10×1	36	0.6	9 510	14 500
CF10-1UUA	CF10-1UURA	60	10	26	12	M10×1.25	36	0.6	5 390	6 860
CF10-1VUUA	CF10-1VUURA	60	10	26	12	M10×1.25	36	0.6	9 510	14 500
CF10-1UUA-K	CF10-1UURA-K	60	10	26	12	M10×1	36	0.6	5 390	6 860
CF10-1VUUA-K	CF10-1VUURA-K	60	10	26	12	M10×1	36	0.6	9 510	14 500
CF12UUA	CF12UURA	95	12	30	14	M12×1.5	40	0.6	7 940	9 800
CF12VUUA	CF12VUURA	95	12	30	14	M12×1.5	40	0.6	13 430	19 700
CF12-1UUA	CF12-1UURA	105	12	32	14	M12×1.5	40	0.6	7 940	9 800
CF12-1VUUA	CF12-1VUURA	105	12	32	14	M12×1.5	40	0.6	13 430	19 700
CF16UUA	CF16UURA	170	16	35	18	M16×1.5	52	0.8	12 050	18 330
CF16VUUA	CF16VUURA	170	16	35	18	M16×1.5	52	0.8	20 680	37 630
CF18UUA	CF18UURA	250	18	40	20	M18×1.5	58	0.8	14 700	25 200
CF18VUUA	CF18VUURA	250	18	40	20	M18×1.5	58	0.8	25 280	51 350
CF20UUA	CF20UURA	460	20	52	24	M20×1.5	66	0.8	20 680	34 600
CF20VUUA	CF20VUURA	460	20	52	24	M20×1.5	66	0.8	33 120	64 480
CF20-1UUA	CF20-1UURA	385	20	47	24	M20×1.5	66	0.8	20 680	34 600
CF20-1VUUA	CF20-1VUURA	385	20	47	24	M20×1.5	66	0.8	33 120	64 480
CF24UUA	CF24UURA	815	24	62	29	M24×1.5	80	0.8	30 480	52 630
CF24VUUA	CF24VUURA	815	24	62	29	M24×1.5	80	0.8	46 550	92 020
CF24-1UUA	CF24-1UURA	1 140	24	72	29	M24×1.5	80	0.8	30 480	52 630
CF24-1VUUA	CF24-1VUURA	1 140	24	72	29	M24×1.5	80	0.8	46 550	92 020
CF30UUA	CF30UURA	1 870	30	80	35	M30×1.5	100	1	45 370	85 060

Stud diameter (d) 3 to 10mm : No grease refilling hole is provided (except "K" type)

INTERCHANGE

INTERCHANGE TABLE

INA		NTN		IKO		MCGILL	
CYLINDRICAL OUTER RING	CROWNED OUTER RING	CYLINDRICAL OUTER RING	CROWNED OUTER RING	CYLINDRICAL OUTER RING	CROWNED OUTER RING	CYLINDRICAL OUTER RING	CROWNED OUTER RING
KR-XSKPP	KR-SKPP	KR-LLXH	KR-LLH	CF-BUU	CF-BUUR	MCFR-SBX	MCFR-SB
—	—	KR10LLT2XH/3AS	KR10LLT2H/3AS	CF3BUU	CF3BUUR	—	—
—	—	KRV10LLT2XH/3AS	KRV10LLT2H/3AS	—	—	—	—
—	—	KR12LLT2XH/3AS	KR12LLT2H/3AS	CF4BUU	CF4BUUR	—	—
—	—	KRV12LLT2XH/3AS	KRV12LLT2H/3AS	—	—	—	—
—	—	KR13LLT2XH/3AS	KR13LLT2H/3AS	CF5BUU	CF5BUUR	MCFR-13SBX	MCFR-13SB
—	—	KRV13LLT2XH/3AS	KRV13LLT2H/3AS	—	—	MCF-13SBX	MCF-13SB
KR16X-SK-PP	KR16-SK-PP	KR16XLLH	KR16LLH	CF6BUU	CF6BUUR	MCFR-16SBX	MCFR-16SB
KRV16X-SK-PP	KRV16-SK-PP	KRV16XLLH/3AS	KRV16LLH/3AS	CF6VBUU	CF6VBUUR	MCF-16SBX	MCF-16SB
KR19X-SK-PP	KR19-SK-PP	KR19XLLH	KR19LLH	CF8BUU	CF8BUUR	MCFR-19SBX	MCFR-19SB
KRV19X-SK-PP	KRV19-SK-PP	KRV19XLLH/3AS	KRV19LLH/3AS	CF8VBUU	CF8VBUUR	MCF-19SBX	MCF-19SB
—	—	KR22XLLH	KR22LLH	CF10BUU	CF10BUUR	MCFR-22SBXA	MCFR-22SBA
—	—	KRV22XLLH/3AS	KRV22LLH/3AS	CF10VBUU	CF10VBUUR	MCF-22SBXA	MCF-22SBA
KR22X-SK-PP	KR22-SK-PP	—	—	CF10BUUM	CF10BUURM	MCFR-22SBX	MCFR-22SB
KRV22X-SK-PP	KRV22-SK-PP	—	—	CF10VBUUM	CF10VBUURM	MCF-22SBX	MCF-22SB
—	—	KR26XLLH	KR26LLH	CF10-1BUU	CF10-1BUUR	MCFR-26SBXA	MCFR-26SBA
—	—	KRV26XLLH/3AS	KRV26LLH/3AS	CF10-1VBUU	CF10-1VBUUR	MCF-26SBXA	MCF-26SBA
KR26X-SK-PP	KR26-SK-PP	—	—	CF10-1BUUM	CF10-1BUURM	MCFR-26SBX	MCFR-26SB
KRV26X-SK-PP	KRV26-SK-PP	—	—	CF10-1VBUUM	CF10-1VBUURM	MCF-26SBX	MCF-26SB
KR30X-SK-PP	KR30-SK-PP	KR30XLLH	KR30LLH	CF12BUU	CF12BUUR	MCFR-30SBX	MCFR-30SB
KRV30X-SK-PP	KRV30-SK-PP	KRV30XLLH/3AS	KRV30LLH/3AS	CF12VBUU	CF12VBUUR	MCF-30SBX	MCF-30SB
KR32X-SK-PP	KR32-SK-PP	KR32XLLH	KR32LLH	CF12-1BUU	CF12-1BUUR	MCFR-32SBX	MCFR-32SB
KRV32X-SK-PP	KRV32-SK-PP	KRV32XLLH/3AS	KRV32LLH/3AS	CF12-1VBUU	CF12-1VBUUR	MCF-32SBX	MCF-32SB
KR35X-SK-PP	KR35-SK-PP	KR35XLLH	KR35LLH	CF16BUU	CF16BUUR	MCFR-35SBX	MCFR-35SB
KRV35X-SK-PP	KRV35-SK-PP	KRV35XLLH/3AS	KRV35LLH/3AS	CF16VBUU	CF16VBUUR	MCF-35SBX	MCF-35SB
KR40X-SK-PP	KR40-SK-PP	KR40XLLH	KR40LLH	CF18BUU	CF18BUUR	MCFR-40SBXA	MCFR-40SBA
KRV40X-SK-PP	KRV40-SK-PP	KRV40XLLH/3AS	KRV40LLH/3AS	CF18VBUU	CF18VBUUR	MCF-40SBXA	MCF-40SBA
KR52X-SK-PP	KR52-SK-PP	KR52XLLH	KR52LLH	CF20BUU	CF20BUUR	MCFR-52SBXA	MCFR-52SBA
KRV52X-SK-PP	KRV52-SK-PP	KRV52XLLH/3AS	KRV52LLH/3AS	CF20VBUU	CF20VBUUR	MCF-52SBXA	MCF-52SBA
KR47X-SK-PP	KR47-SK-PP	KR47XLLH	KR47LLH	CF20-1BUU	CF20-1BUUR	MCFR-47SBXA	MCFR-47SBA
KRV47X-SK-PP	KRV47-SK-PP	KRV47XLLH/3AS	KRV47LLH/3AS	CF20-1VBUU	CF20-1VBUUR	MCF-47SBXA	MCF-47SBA
KR62X-SK-PP	KR62-SK-PP	KR62XLLH	KR62LLH	CF24BUU	CF24BUUR	MCFR-62SBXA	MCFR-62SBA
KRV62X-SK-PP	KRV62-SK-PP	KRV62XLLH/3AS	KRV62LLH/3AS	CF24VBUU	CF24VBUUR	MCF-62SBXA	MCF-62SBA
KR72X-SK-PP	KR72-SK-PP	KR72XLLH	KR72LLH	CF24-1BUU	CF24-1BUUR	MCFR-72SBXA	MCFR-72SBA
KRV72X-SK-PP	KRV72-SK-PP	KRV72XLLH/3AS	KRV72LLH/3AS	CF24-1VBUU	CF24-1VBUUR	MCF-72SBXA	MCF-72SBA
KR80X-SK-PP	KR80-SK-PP	KR80XLLH	KR80LLH	CF30BUU	CF30BUUR	MCFR-80SBX	MCFR-80SB



INTERCHANGE

CAM FOLLOWERS

HEXAGON SOCKET ON STUD HEAD

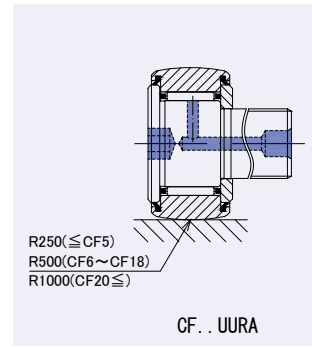
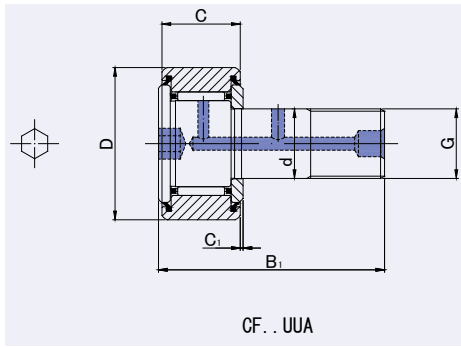

CF..UUA, UURA

DIMENSION TABLE

JNS NUMBER CYLINDRICAL OUTER RING	JNS NUMBER CROWNED OUTER RING	Mass (Approx.)	Dimensions(mm)						Basic dynamic load rating	Basic static load rating	
			CF..UUA	CF..UURA	g	d	D	C			G
CF30VUUA	CF30VUURA	1 870		30	80	35	M30×1.5	100	1	67 620	144 060
CF30-1UUA	CF30-1UURA	2 030		30	85	35	M30×1.5	100	1	45 370	85 060
CF30-1VUUA	CF30-1VUURA	2 030		30	85	35	M30×1.5	100	1	67 620	144 060
CF30-2UUA	CF30-2UURA	2 220		30	90	35	M30×1.5	100	1	45 370	85 060
CF30-2VUUA	CF30-2VUURA	2 220		30	90	35	M30×1.5	100	1	67 620	144 060

Stud diameter (d) 3 to 10mm : No grease refilling hole is provided (except "K" type)



INTERCHANGE

INTERCHANGE TABLE

INA		NTN		IKO		MCGILL	
CYLINDRICAL OUTER RING	CROWNED OUTER RING	CYLINDRICAL OUTER RING	CROWNED OUTER RING	CYLINDRICAL OUTER RING	CROWNED OUTER RING	CYLINDRICAL OUTER RING	CROWNED OUTER RING
KR-XSKPP	KR-SKPP	KR-LLXH	KR-LLH	CF-BUU	CF-BUUR	MCFR-SBX	MCFR-SB
KRV80X-SK-PP	KRV80-SK-PP	KRV80XLLH/3AS	KRV80LLH/3AS	CF30VBUU	CF30VBUUR	MCF-80SBX	MCF-80SB
KR85X-SK-PP	KR85-SK-PP	—	—	CF30-1BUU	CF30-1BUUR	MCFR-85SBX	MCFR-85SB
KRV85X-SK-PP	KRV85-SK-PP	—	—	CF30-1VBUU	CF30-1VBUUR	MCF-85SBX	MCF-85SB
KR90X-SK-PP	KR90-SK-PP	KR90XLLH	KR90LLH	CF30-2BUU	CF30-2BUUR	MCFR-90SBX	MCFR-90SB
KRV90X-SK-PP	KRV90-SK-PP	KRV90XLLH/3AS	KRV90LLH/3AS	CF30-2VBUU	CF30-2VBUUR	MCF-90SBX	MCF-90SB



INTERCHANGE

CAM FOLLOWERS

HEXAGON SOCKET ON BOTH SIDES
GREASE NIPPLE INSTALLED

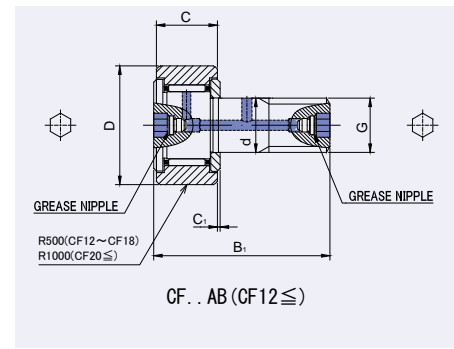
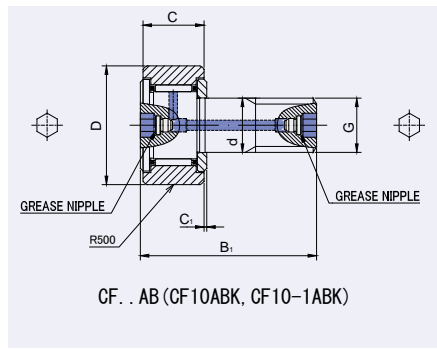

CF..AB, RAB, UUAB, UURAB

DIMENSION TABLE

JNS NUMBER CYLINDRICAL OUTER RING WITHOUT SEALS	JNS NUMBER CROWNED OUTER RING WITHOUT SEALS	JNS NUMBER CYLINDRICAL OUTER RING WITH SEALS	JNS NUMBER CROWNED OUTER RING WITH SEALS	Mass (Approx.) g	Dimensions(mm)						Basic dynamic load rating Cr N	Basic static load rating Cor N
					d	D	C	G	B1	C1		
CF10ABK	CF10RABK	CF10UUABK	CF10UURABK	45	10	22	12	M10×1	36	0.6	4 700	1 670
CF10VABK	CF10VRABK	CF10VUUABK	CF10VUURABK	45	10	22	12	M10×1	36	0.6	4 700	1 670
CF10-1ABK	CF10-1RABK	CF10-1UUABK	CF10-1UURABK	60	10	26	12	M10×1	36	0.6	5 490	2 060
CF10-1VABK	CF10-1VRABK	CF10-1VUUABK	CF10-1VUURABK	60	10	26	12	M10×1	36	0.6	5 490	2 060
CF12AB	CF12RAB	CF12UUAB	CF12UURAB	95	12	30	14	M12×1.5	40	0.6	7 060	2 450
CF12VAB	CF12VRAB	CF12VUUAB	CF12VUURAB	95	12	30	14	M12×1.5	40	0.6	7 060	2 450
CF12-1AB	CF12-1RAB	CF12-1UUAB	CF12-1UURAB	105	12	32	14	M12×1.5	40	0.6	7 450	2 740
CF12-1VAB	CF12-1VRAB	CF12-1VUUAB	CF12-1VUURAB	105	12	32	14	M12×1.5	40	0.6	7 450	2 740
CF16AB	CF16RAB	CF16UUAB	CF16UURAB	170	16	35	18	M16×1.5	52	0.8	11 200	3 140
CF16VAB	CF16VRAB	CF16VUUAB	CF16VUURAB	170	16	35	18	M16×1.5	52	0.8	11 200	3 140
CF18AB	CF18RAB	CF18UUAB	CF18UURAB	250	18	40	20	M18×1.5	58	0.8	14 400	3 720
CF18VAB	CF18VRAB	CF18VUUAB	CF18VUURAB	250	18	40	20	M18×1.5	58	0.8	14 400	3 720
CF20AB	CF20RAB	CF20UUAB	CF20UURAB	460	20	52	24	M20×1.5	66	0.8	23 200	8 230
CF20VAB	CF20VRAB	CF20VUUAB	CF20VUURAB	460	20	52	24	M20×1.5	66	0.8	23 200	8 230
CF20-1AB	CF20-1RAB	CF20-1UUAB	CF20-1UURAB	385	20	47	24	M20×1.5	66	0.8	21 000	7 150
CF20-1VAB	CF20-1VRAB	CF20-1VUUAB	CF20-1VUURAB	385	20	47	24	M20×1.5	66	0.8	21 000	7 150
CF24AB	CF24RAB	CF24UUAB	CF24UURAB	815	24	62	29	M24×1.5	80	0.8	34 200	10 500
CF24VAB	CF24VRAB	CF24VUUAB	CF24VUURAB	815	24	62	29	M24×1.5	80	0.8	34 200	10 500
CF24-1AB	CF24-1RAB	CF24-1UUAB	CF24-1UURAB	1 140	24	72	29	M24×1.5	80	0.8	39 800	12 900
CF24-1VAB	CF24-1VRAB	CF24-1VUUAB	CF24-1VUURAB	1 140	24	72	29	M24×1.5	80	0.8	39 800	12 900
CF30AB	CF30RAB	CF30UUAB	CF30UURAB	1 870	30	80	35	M30×1.5	100	1	52 600	14 900
CF30VAB	CF30VRAB	CF30VUUAB	CF30VUURAB	1 870	30	80	35	M30×1.5	100	1	52 600	14 900
CF30-1AB	CF30-1RAB	CF30-1UUAB	CF30-1UURAB	2 030	30	85	35	M30×1.5	100	1	56 000	16 100
CF30-1VAB	CF30-1VRAB	CF30-1VUUAB	CF30-1VUURAB	2 030	30	85	35	M30×1.5	100	1	56 000	16 100
CF30-2AB	CF30-2RAB	CF30-2UUAB	CF30-2UURAB	2 220	30	90	35	M30×1.5	100	1	59 300	17 300
CF30-2VAB	CF30-2VRAB	CF30-2VUUAB	CF30-2VUURAB	2 220	30	90	35	M30×1.5	100	1	59 300	17 300



INTERCHANGE

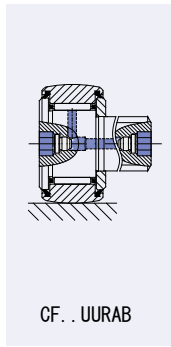
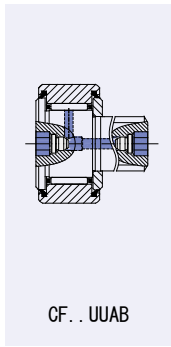
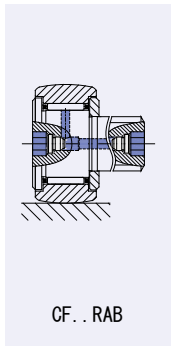
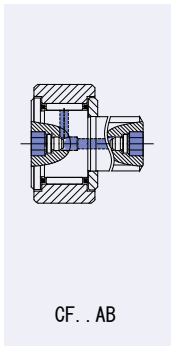

INTERCHANGE TABLE

INA				NTN		IKO		MCGILL	
CYLINDRICAL OUTER RING WITHOUT SEALS	CROWNED OUTER RING WITHOUT SEALS	CYLINDRICAL OUTER RING WITH SEALS	CROWNED OUTER RING WITH SEALS	CYLINDRICAL OUTER RING WITHOUT SEALS	CROWNED OUTER RING WITHOUT SEALS	CYLINDRICAL OUTER RING WITHOUT SEALS	CROWNED OUTER RING WITHOUT SEALS	CYLINDRICAL OUTER RING WITHOUT SEALS	CROWNED OUTER RING WITHOUT SEALS
KR-X	KR	KR-PPX	KR-PP	—	—	—	—	—	—
KR22X	KR22	KR22PPX	KR22PP	—	—	—	—	—	—
KRV22X	KRV22	KRV22PPX	KRV22PP	—	—	—	—	—	—
KR26X	KR26	KR26PPX	KR26PP	—	—	—	—	—	—
KRV26X	KRV26	KRV26PPX	KRV26PP	—	—	—	—	—	—
KR30X	KR30	KR30PPX	KR30PP	—	—	—	—	—	—
KRV30X	KRV30	KRV30PPX	KRV30PP	—	—	—	—	—	—
KR32X	KR32	KR32PPX	KR32PP	—	—	—	—	—	—
KRV32X	KRV32	KRV32PPX	KRV32PP	—	—	—	—	—	—
KR35X	KR35	KR35PPX	KR35PP	—	—	—	—	—	—
KRV35X	KRV35	KRV35PPX	KRV35PP	—	—	—	—	—	—
KR40X	KR40	KR40PPX	KR40PP	—	—	—	—	—	—
KRV40X	KRV40	KRV40PPX	KRV40PP	—	—	—	—	—	—
KR52X	KR52	KR52PPX	KR52PP	—	—	—	—	—	—
KRV52X	KRV52	KRV52PPX	KRV52PP	—	—	—	—	—	—
KR47X	KR47	KR47PPX	KR47PP	—	—	—	—	—	—
KRV47X	KRV47	KRV47PPX	KRV47PP	—	—	—	—	—	—
KR62X	KR62	KR62PPX	KR62PP	—	—	—	—	—	—
KRV62X	KRV62	KRV62PPX	KRV62PP	—	—	—	—	—	—
KR72X	KR72	KR72PPX	KR72PP	—	—	—	—	—	—
KRV72X	KRV72	KRV72PPX	KRV72PP	—	—	—	—	—	—
KR80X	KR80	KR80PPX	KR80PP	—	—	—	—	—	—
KRV80X	KRV80	KRV80PPX	KRV80PP	—	—	—	—	—	—
—	—	—	—	—	—	—	—	—	—
—	—	—	—	—	—	—	—	—	—
KR90X	KR90	KR90PPX	KR90PP	—	—	—	—	—	—
KRV90X	KRV90	KRV90PPX	KRV90PP	—	—	—	—	—	—



INTERCHANGE

CAM FOLLOWERS

FULL COMPLEMENT DOUBLE ROW
HEXAGON SOCKET ON BOTH SIDES
GREASE NIPPLE INSTALLED

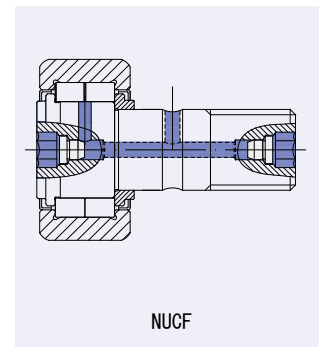
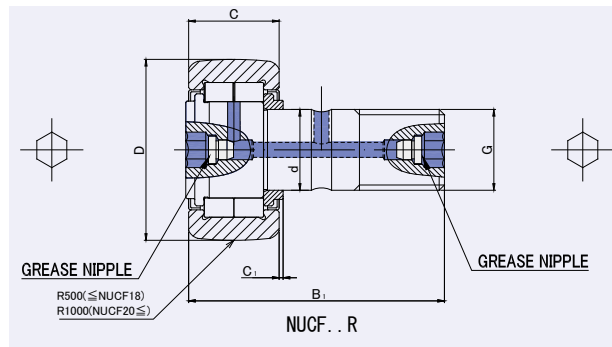

NUCF..AB, RAB

DIMENSION TABLE

JNS NUMBER CYLINDRICAL OUTER RING	JNS NUMBER CROWNED OUTER RING	Mass (Approx.)	Dimensions(mm)						Basic dynamic load rating	Basic static load rating
			d	D	C	G	B1	C1		
NUCF..AB	NUCF..RAB	g	d	D	C	G	B1	C1	Cr N	Cor N
NUCF16AB	NUCF16RAB	165	16	35	18	M16x1.5	32.5	0.8	22 300	25 700
NUCF18AB	NUCF18RAB	242	18	40	20	M18x1.5	36.5	0.8	24 100	29 100
NUCF20-1AB	NUCF20-1RAB	380	20	47	24	M20x1.5	40.5	0.8	38 500	48 000
NUCF20AB	NUCF20RAB	450	20	52	24	M20x1.5	40.5	0.8	42 500	57 500
NUCF24AB	NUCF24RAB	795	24	62	28	M24x1.5	49.5	1.3	56 500	72 500
NUCF24-1AB	NUCF24-1RAB	1 010	24	72	28	M24x1.5	49.5	1.3	62 000	85 500
NUCF30AB	NUCF30RAB	1 540	30	80	35	M30x1.5	63	1	101 000	151 000
NUCF30-2AB	NUCF30-2RAB	1 960	30	90	35	M30x1.5	63	1	101 000	151 000



INTERCHANGE

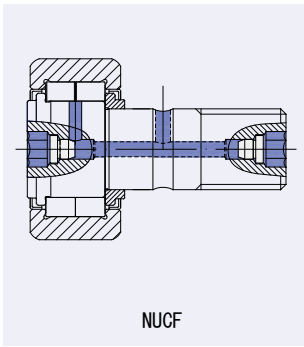

INTERCHANGE TABLE

INA		NTN		IKO		MCGILL	
CYLINDRICAL OUTER RING	CROWNED OUTER RING	CYLINDRICAL OUTER RING	CROWNED OUTER RING	CYLINDRICAL OUTER RING	CROWNED OUTER RING	CYLINDRICAL OUTER RING	CROWNED OUTER RING
—	NUKR	NUKR..X	NUKR	—	NUCF..R	MCFD..X	MCFD
—	NUKR35	NUKR35XH	NUKR35H	—	NUCF16BR	MCFD-35X	MCFD-35
—	NUKR40	NUKR40XH	NUKR40H	—	NUCF18BR	MCFD-40X	MCFD-40
—	NUKR47	NUKR47XH	NUKR47H	—	NUCF20-1BR	MCFD-47X	MCFD-47
—	NUKR52	NUKR52XH	NUKR52H	—	NUCF20BR	MCFD-52X	MCFD-52
—	NUKR62	NUKR62XH	NUKR62H	—	NUCF24BR	MCFD-62X	MCFD-62
—	NUKR72	NUKR72XH	NUKR72H	—	NUCF24-1BR	MCFD-72X	MCFD-72
—	NUKR80	NUKR80XH	NUKR80H	—	NUCF30BR	MCFD-80X	MCFD-80
—	NUKR90	NUKR90XH	NUKR90H	—	NUCF30-2BR	MCFD-90X	MCFD-90



CAM FOLLOWERS SCREWDRIVER SLOT HEAD

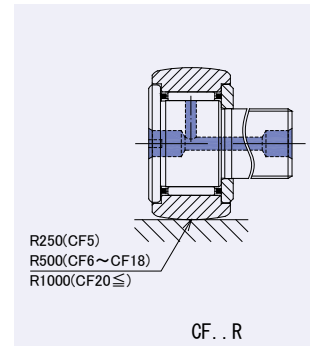
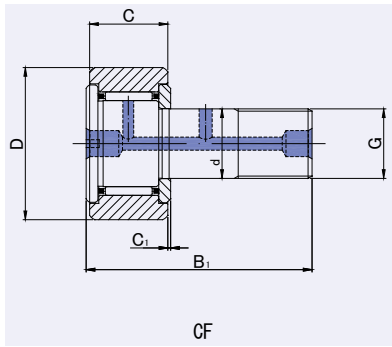

CF, R

DIMENSION TABLE

JNS NUMBER CYLINDRICAL OUTER RING	JNS NUMBER CROWNED OUTER RING	Mass (Approx.) g	Dimensions(mm)						Basic dynamic load rating Cr N	Basic static load rating Cor N
			d	D	C	G	B1	C1		
CF	CF..R									
CF5	CF5R	10.5	5	13	9	M5×0.8	23	0.5	3 140	2 770
CF5V	CF5VR	10.5	5	13	9	M5×0.8	23	0.5	5 100	5 500
CF6	CF6R	18.5	6	16	11	M6×1	28	0.6	3 630	3 630
CF6V	CF6VR	18.5	6	16	11	M6×1	28	0.6	6 960	8 530
CF8	CF8R	28.5	8	19	11	M8×1.25	32	0.6	4 310	4 710
CF8V	CF8VR	28.5	8	19	11	M8×1.25	32	0.6	8 130	11 170
CF10	CF10R	45	10	22	12	M10×1.25	36	0.6	5 390	6 860
CF10V	CF10VR	45	10	22	12	M10×1.25	36	0.6	9 510	14 500
CF10K	CF10RK	45	10	22	12	M10×1	36	0.6	5 390	6 860
CF10VK	CF10VRK	45	10	22	12	M10×1	36	0.6	9 510	14 500
CF10-1	CF10-1R	60	10	26	12	M10×1.25	36	0.6	5 390	6 860
CF10-1V	CF10-1VR	60	10	26	12	M10×1.25	36	0.6	9 510	14 500
CF10-1K	CF10-1RK	60	10	26	12	M10×1	36	0.6	5 390	6 860
CF10-1VK	CF10-1VRK	60	10	26	12	M10×1	36	0.6	9 510	14 500
CF12	CF12R	95	12	30	14	M12×1.5	40	0.6	7 940	9 800
CF12V	CF12VR	95	12	30	14	M12×1.5	40	0.6	13 430	19 700
CF12-1	CF12-1R	105	12	32	14	M12×1.5	40	0.6	7 940	9 800
CF12-1V	CF12-1VR	105	12	32	14	M12×1.5	40	0.6	13 430	19 700
CF16	CF16R	170	16	35	18	M16×1.5	52	0.8	12 050	18 330
CF16V	CF16VR	170	16	35	18	M16×1.5	52	0.8	20 680	37 630
CF18	CF18R	250	18	40	20	M18×1.5	58	0.8	14 700	25 200
CF18V	CF18VR	250	18	40	20	M18×1.5	58	0.8	25 280	51 350
CF20	CF20R	460	20	52	24	M20×1.5	66	0.8	20 680	34 600
CF20V	CF20VR	460	20	52	24	M20×1.5	66	0.8	33 120	64 480
CF20-1	CF20-1R	385	20	47	24	M20×1.5	66	0.8	20 680	34 600
CF20-1V	CF20-1VR	385	20	47	24	M20×1.5	66	0.8	33 120	64 480
CF24	CF24R	815	24	62	29	M24×1.5	80	0.8	30 480	52 630
CF24V	CF24VR	815	24	62	29	M24×1.5	80	0.8	46 550	92 020
CF24-1	CF24-1R	1 140	24	72	29	M24×1.5	80	0.8	30 480	52 630
CF24-1V	CF24-1VR	1 140	24	72	29	M24×1.5	80	0.8	46 550	92 020
CF30	CF30R	1 870	30	80	35	M30×1.5	100	1	45 370	85 060
CF30V	CF30VR	1 870	30	80	35	M30×1.5	100	1	67 620	144 060
CF30-1	CF30-1R	2 030	30	85	35	M30×1.5	100	1	45 370	85 060
CF30-1V	CF30-1VR	2 030	30	85	35	M30×1.5	100	1	67 620	144 060
CF30-2	CF30-2R	2 220	30	90	35	M30×1.5	100	1	45 370	85 060
CF30-2V	CF30-2VR	2 220	30	90	35	M30×1.5	100	1	67 620	144 060

Stud diameter (d) 5 to 10mm : Without oil hole in the thread side.(except "K" type)



INTERCHANGE

INTERCHANGE TABLE

INA		NTN		IKO		MCGILL	
CYLINDRICAL OUTER RING	CROWNED OUTER RING	CYLINDRICAL OUTER RING	CROWNED OUTER RING	CYLINDRICAL OUTER RING	CROWNED OUTER RING	CYLINDRICAL OUTER RING	CROWNED OUTER RING
KR-X	KR	KR-X	KR	CF	CF..R	MCFR-X	MCFR
—	—	—	—	CF5	CF5R	MCFR-13X	MCFR-13
—	—	—	—	CF5V	CF5VR	MCF-13X	MCF-13
KR16X	KR16	KR16X	KR16	CF6	CF6R	MCFR-16X	MCFR-16
KRV16X	KRV16	KRV16X	KRV16	CF6V	CF6VR	MCF-16X	MCF-16
KR19X	KR19	KR19X	KR19	CF8	CF8R	MCFR-19X	MCFR-19
KRV19X	KRV19	KRV19X	KRV19	CF8V	CF8VR	MCF-19X	MCF-19
—	—	KR22X	KR22	CF10	CF10R	MCFR-22XA	MCFR-22A
—	—	KRV22X	KRV22	CF10V	CF10VR	MCF-22XA	MCF-22A
—	—	—	—	CF10M	CF10RM	MCFR-22X	MCFR-22
—	—	—	—	CF10VM	CF10VRM	MCF-22X	MCF-22
—	—	KR26X	KR26	CF10-1	CF10-1R	MCFR-26XA	MCFR-26A
—	—	KRV26X	KRV26	CF10-1V	CF10-1VR	MCF-26XA	MCF-26A
—	—	—	—	CF10-1M	CF10-1RM	MCFR-26X	MCFR-26
—	—	—	—	CF10-1VM	CF10-1VRM	MCF-26X	MCF-26
—	—	KR30X	KR30	CF12	CF12R	MCFR-30X	MCFR-30
—	—	KRV30X	KRV30	CF12V	CF12VR	MCF-30X	MCF-30
—	—	KR32X	KR32	CF12-1	CF12-1R	MCFR-32X	MCFR-32
—	—	KRV32X	KRV32	CF12-1V	CF12-1VR	MCF-32X	MCF-32
—	—	KR35X	KR35	CF16	CF16R	MCFR-35X	MCFR-35
—	—	KRV35X	KRV35	CF16V	CF16VR	MCF-35X	MCF-35
—	—	KR40X	KR40	CF18	CF18R	MCFR-40XA	MCFR-40A
—	—	KRV40X	KRV40	CF18V	CF18VR	MCF-40XA	MCF-40A
—	—	KR52X	KR52	CF20	CF20R	MCFR-52XA	MCFR-52A
—	—	KRV52X	KRV52	CF20V	CF20VR	MCF-52XA	MCF-52A
—	—	KR47X	KR47	CF20-1	CF20-1R	MCFR-47XA	MCFR-47A
—	—	KRV47X	KRV47	CF20-1V	CF20-1VR	MCF-47XA	MCF-47A
—	—	KR62X	KR62	CF24	CF24R	MCFR-62XA	MCFR-62A
—	—	KRV62X	KRV62	CF24V	CF24VR	MCF-62XA	MCF-62A
—	—	KR72X	KR72	CF24-1	CF24-1R	MCFR-72XA	MCFR-72A
—	—	KRV72X	KRV72	CF24-1V	CF24-1VR	MCF-72XA	MCF-72A
—	—	KR80X	KR80	CF30	CF30R	MCFR-80X	MCFR-80
—	—	KRV80X	KRV80	CF30V	CF30VR	MCF-80X	MCF-80
—	—	KR85X	KR85	CF30-1	CF30-1R	MCFR-85X	MCFR-85
—	—	KRV85X	KRV85	CF30-1V	CF30-1VR	MCF-85X	MCF-85
—	—	KR90X	KR90	CF30-2	CF30-2R	MCFR-90X	MCFR-90
—	—	KRV90X	KRV90	CF30-2V	CF30-2VR	MCF-90X	MCF-90



INTERCHANGE

CAM FOLLOWERS SCREWDRIVER SLOT HEAD

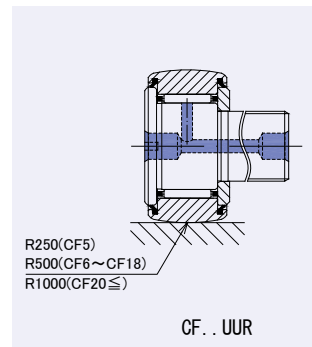
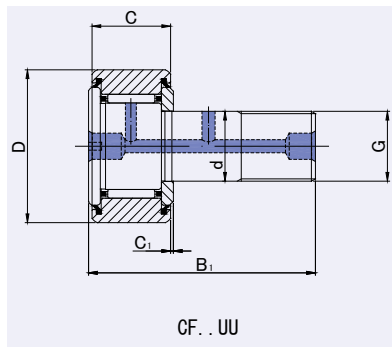

CF..UU, UUR

DIMENSION TABLE

JNS NUMBER CYLINDRICAL OUTER RING	JNS NUMBER CROWNED OUTER RING	Mass (Approx.) g	Dimensions(mm)						Basic dynamic load rating Cr N	Basic static load rating Cor N
			d	D	C	G	B1	C1		
CF5UU	CF5UUR	10.5	5	13	9	M5×0.8	23	0.5	3 140	2 770
CF5VUU	CF5VUUR	10.5	5	13	9	M5×0.8	23	0.5	5 100	5 500
CF6UU	CF6UUR	18.5	6	16	11	M6×1	28	0.6	3 630	3 630
CF6VUU	CF6VUUR	18.5	6	16	11	M6×1	28	0.6	6 960	8 530
CF8UU	CF8UUR	28.5	8	19	11	M8×1.25	32	0.6	4 310	4 710
CF8VUU	CF8VUUR	28.5	8	19	11	M8×1.25	32	0.6	8 130	11 170
CF10UU	CF10UUR	45	10	22	12	M10×1.25	36	0.6	5 390	6 860
CF10VUU	CF10VUUR	45	10	22	12	M10×1.25	36	0.6	9 510	14 500
CF10UUK	CF10UURK	45	10	22	12	M10×1	36	0.6	5 390	6 860
CF10VUUK	CF10VUURK	45	10	22	12	M10×1	36	0.6	9 510	14 500
CF10-1UU	CF10-1UUR	60	10	26	12	M10×1.25	36	0.6	5 390	6 860
CF10-1VUU	CF10-1VUUR	60	10	26	12	M10×1.25	36	0.6	9 510	14 500
CF10-1UUK	CF10-1UURK	60	10	26	12	M10×1	36	0.6	5 390	6 860
CF10-1VUUK	CF10-1VUURK	60	10	26	12	M10×1	36	0.6	9 510	14 500
CF12UU	CF12UUR	95	12	30	14	M12×1.5	40	0.6	7 940	9 800
CF12VUU	CF12VUUR	95	12	30	14	M12×1.5	40	0.6	13 430	19 700
CF12-1UU	CF12-1UUR	105	12	32	14	M12×1.5	40	0.6	7 940	9 800
CF12-1VUU	CF12-1VUUR	105	12	32	14	M12×1.5	40	0.6	13 430	19 700
CF16UU	CF16UUR	170	16	35	18	M16×1.5	52	0.8	12 050	18 330
CF16VUU	CF16VUUR	170	16	35	18	M16×1.5	52	0.8	20 680	37 630
CF18UU	CF18UUR	250	18	40	20	M18×1.5	58	0.8	14 700	25 200
CF18VUU	CF18VUUR	250	18	40	20	M18×1.5	58	0.8	25 280	51 350
CF20UU	CF20UUR	460	20	52	24	M20×1.5	66	0.8	20 680	34 600
CF20VUU	CF20VUUR	460	20	52	24	M20×1.5	66	0.8	33 120	64 480
CF20-1UU	CF20-1UUR	385	20	47	24	M20×1.5	66	0.8	20 680	34 600
CF20-1VUU	CF20-1VUUR	385	20	47	24	M20×1.5	66	0.8	33 120	64 480
CF24UU	CF24UUR	815	24	62	29	M24×1.5	80	0.8	30 480	52 630
CF24VUU	CF24VUUR	815	24	62	29	M24×1.5	80	0.8	46 550	92 020
CF24-1UU	CF24-1UUR	1 140	24	72	29	M24×1.5	80	0.8	30 480	52 630
CF24-1VUU	CF24-1VUUR	1 140	24	72	29	M24×1.5	80	0.8	46 550	92 020
CF30UU	CF30UUR	1 870	30	80	35	M30×1.5	100	1	45 370	85 060
CF30VUU	CF30VUUR	1 870	30	80	35	M30×1.5	100	1	67 620	144 060
CF30-1UU	CF30-1UUR	2 030	30	85	35	M30×1.5	100	1	45 370	85 060
CF30-1VUU	CF30-1VUUR	2 030	30	85	35	M30×1.5	100	1	67 620	144 060
CF30-2UU	CF30-2UUR	2 220	30	90	35	M30×1.5	100	1	45 370	85 060
CF30-2VUU	CF30-2VUUR	2 220	30	90	35	M30×1.5	100	1	67 620	144 060

Stud diameter (d) 5 to 10mm : Without oil hole in the thread side.(except "K" type)



INTERCHANGE

INTERCHANGE TABLE

INA		NTN		IKO		MCGILL	
CYLINDRICAL OUTER RING	CROWNED OUTER RING	CYLINDRICAL OUTER RING	CROWNED OUTER RING	CYLINDRICAL OUTER RING	CROWNED OUTER RING	CYLINDRICAL OUTER RING	CROWNED OUTER RING
KR-PPX	KR-PP	KR-LLX	KR-LL	CF	CF..R	MCFR-SX	MCFR-S
—	—	—	—	CF5UU	CF5UUR	MCFR-13SX	MCFR-13S
—	—	—	—	CF5VUU	CF5VUUR	MCF-13SX	MCF-13S
KR16PPX	KR16PP	KR16XLL	KR16LL	CF6UU	CF6UUR	MCFR-16SX	MCFR-16S
KRV16PPX	KRV16PP	KRV16XLL	KRV16LL	CF6VUU	CF6VUUR	MCF-16SX	MCF-16S
KR19PPX	KR19PP	KR19XLL	KR19LL	CF8UU	CF8UUR	MCFR-19SX	MCFR-19S
KRV19PPX	KRV19PP	KRV19XLL	KRV19LL	CF8VUU	CF8VUUR	MCF-19SX	MCF-19S
—	—	KR22XLL	KR22LL	CF10UU	CF10UUR	MCFR-22SXA	MCFR-22SA
—	—	KRV22XLL	KRV22LL	CF10VUU	CF10VUUR	MCF-22SXA	MCF-22SA
—	—	—	—	CF10UUM	CF10UURM	MCFR-22SX	MCFR-22S
—	—	—	—	CF10VUUM	CF10VUURM	MCF-22SX	MCF-22S
—	—	KR26XLL	KR26LL	CF10-1UU	CF10-1UUR	MCFR-26SXA	MCFR-26SA
—	—	KRV26XLL	KRV26LL	CF10-1VUU	CF10-1VUUR	MCF-26SXA	MCF-26SA
—	—	—	—	CF10-1UUM	CF10-1UURM	MCFR-26SX	MCFR-26S
—	—	—	—	CF10-1VUUM	CF10-1VUURM	MCF-26SX	MCF-26S
—	—	KR30XLL	KR30LL	CF12UU	CF12UUR	MCFR-30SX	MCFR-30S
—	—	KRV30XLL	KRV30LL	CF12VUU	CF12VUUR	MCF-30SX	MCF-30S
—	—	KR32XLL	KR32LL	CF12-1UU	CF12-1UUR	MCFR-32SX	MCFR-32S
—	—	KRV32XLL	KRV32LL	CF12-1VUU	CF12-1VUUR	MCF-32SX	MCF-32S
—	—	KR35XLL	KR35LL	CF16UU	CF16UUR	MCFR-35SX	MCFR-35S
—	—	KRV35XLL	KRV35LL	CF16VUU	CF16VUUR	MCF-35SX	MCF-35S
—	—	KR40XLL	KR40LL	CF18UU	CF18UUR	MCFR-40SXA	MCFR-40SA
—	—	KRV40XLL	KRV40LL	CF18VUU	CF18VUUR	MCF-40SXA	MCF-40SA
—	—	KR52XLL	KR52LL	CF20UU	CF20UUR	MCFR-52SXA	MCFR-52SA
—	—	KRV52XLL	KRV52LL	CF20VUU	CF20VUUR	MCF-52SXA	MCF-52SA
—	—	KR47XLL	KR47LL	CF20-1UU	CF20-1UUR	MCFR-47SXA	MCFR-47SA
—	—	KRV47XLL	KRV47LL	CF20-1VUU	CF20-1VUUR	MCF-47SXA	MCF-47SA
—	—	KR62XLL	KR62LL	CF24UU	CF24UUR	MCFR-62SXA	MCFR-62SA
—	—	KRV62XLL	KRV62LL	CF24VUU	CF24VUUR	MCF-62SXA	MCF-62SA
—	—	KR72XLL	KR72LL	CF24-1UU	CF24-1UUR	MCFR-72SXA	MCFR-72SA
—	—	KRV72XLL	KRV72LL	CF24-1VUU	CF24-1VUUR	MCF-72SXA	MCF-72SA
—	—	KR80XLL	KR80LL	CF30UU	CF30UUR	MCFR-80SX	MCFR-80S
—	—	KRV80XLL	KRV80LL	CF30VUU	CF30VUUR	MCF-80SX	MCF-80S
—	—	KR85XLL	KR85LL	CF30-1UU	CF30-1UUR	MCFR-85SX	MCFR-85S
—	—	KRV85XLL	KRV85LL	CF30-1VUU	CF30-1VUUR	MCF-85SX	MCF-85S
—	—	KR90XLL	KR90LL	CF30-2UU	CF30-2UUR	MCFR-90SX	MCFR-90S
—	—	KRV90XLL	KRV90LL	CF30-2VUU	CF30-2VUUR	MCF-90SX	MCF-90S



INTERCHANGE

CAM FOLLOWERS

HEXAGON SOCKET ON THREAD SIDE SCREWDRIVER SLOT HEAD

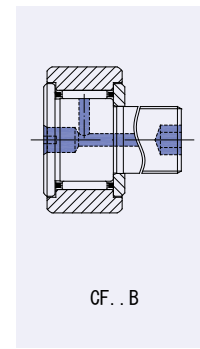
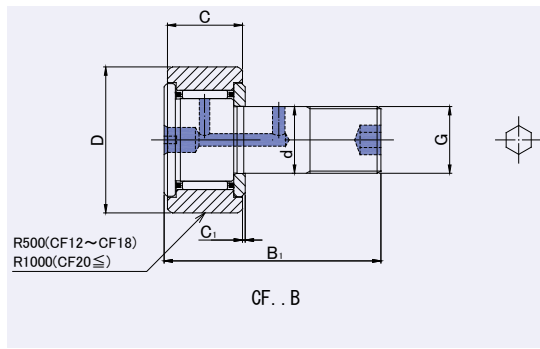

CF.B, RB, UUB, UURB

DIMENSION TABLE

JNS NUMBER CYLINDRICAL OUTER RING WITHOUT SEALS	JNS NUMBER CROWNED OUTER RING WITHOUT SEALS	JNS NUMBER CYLINDRICAL OUTER RING WITH SEALS	JNS NUMBER CROWNED OUTER RING WITH SEALS	Mass (Approx.) g	Dimensions(mm)						Basic dynamic load rating Cr N	Basic static load rating Cor N
					d	D	C	G	B1	C1		
CF12B	CF12RB	CF12UUB	CF12UURB	95	12	30	14	M12×1.5	40	0.6	7 940	9 800
CF12VB	CF12VRB	CF12VUUB	CF12VUURB	95	12	30	14	M12×1.5	40	0.6	13 430	19 700
CF12-1B	CF12-1RB	CF12-1UUB	CF12-1UURB	105	12	32	14	M12×1.5	40	0.6	7 940	9 800
CF12-1VB	CF12-1VRB	CF12-1VUUB	CF12-1VUURB	105	12	32	14	M12×1.5	40	0.6	13 430	19 700
CF16B	CF16RB	CF16UUB	CF16UURB	170	16	35	18	M16×1.5	52	0.8	12 050	18 330
CF16VB	CF16VRB	CF16VUUB	CF16VUURB	170	16	35	18	M16×1.5	52	0.8	20 680	37 630
CF18B	CF18RB	CF18UUB	CF18UURB	250	18	40	20	M18×1.5	58	0.8	14 700	25 200
CF18VB	CF18VRB	CF18VUUB	CF18VUURB	250	18	40	20	M18×1.5	58	0.8	25 280	51 350
CF20B	CF20RB	CF20UUB	CF20UURB	460	20	52	24	M20×1.5	66	0.8	20 680	34 600
CF20VB	CF20VRB	CF20VUUB	CF20VUURB	460	20	52	24	M20×1.5	66	0.8	33 120	64 480
CF20-1B	CF20-1RB	CF20-1UUB	CF20-1UURB	385	20	47	24	M20×1.5	66	0.8	20 680	34 600
CF20-1VB	CF20-1VRB	CF20-1VUUB	CF20-1VUURB	385	20	47	24	M20×1.5	66	0.8	33 120	64 480
CF24B	CF24RB	CF24UUB	CF24UURB	815	24	62	29	M20×1.5	80	0.8	30 480	52 630
CF24VB	CF24VRB	CF24VUUB	CF24VUURB	815	24	62	29	M24×1.5	80	0.8	46 550	92 020
CF24-1B	CF24-1RB	CF24-1UUB	CF24-1UURB	1 140	24	72	29	M20×1.5	80	0.8	30 480	52 630
CF24-1VB	CF24-1VRB	CF24-1VUUB	CF24-1VUURB	1 140	24	72	29	M24×1.5	80	0.8	46 550	92 020
CF30B	CF30RB	CF30UUB	CF30UURB	1 870	30	80	35	M30×1.5	100	1	45 370	85 060
CF30VB	CF30VRB	CF30VUUB	CF30VUURB	1 870	30	80	35	M30×1.5	100	1	67 620	144 060
CF30-1B	CF30-1RB	CF30-1UUB	CF30-1UURB	2 030	30	85	35	M30×1.5	100	1	45 370	85 060
CF30-1VB	CF30-1VRB	CF30-1VUUB	CF30-1VUURB	2 030	30	85	35	M30×1.5	100	1	67 620	144 060
CF30-2B	CF30-2RB	CF30-2UUB	CF30-2UURB	2 220	30	90	35	M30×1.5	100	1	45 370	85 060
CF30-2VB	CF30-2VRB	CF30-2VUUB	CF30-2VUURB	2 220	30	90	35	M30×1.5	100	1	67 620	144 060



INTERCHANGE

CAM FOLLOWERS

SOLID ECCENTRIC TYPE

HEXAGON SOCKET ON STUD HEAD

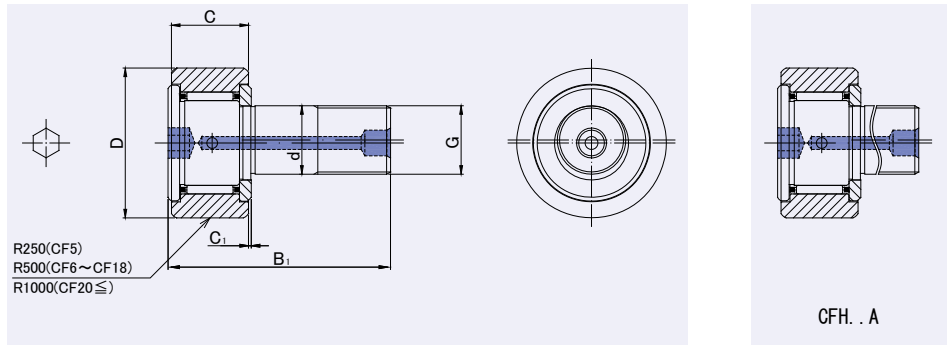

CFH..A, RA, UUA, UURA

DIMENSION TABLE

JNS NUMBER CYLINDRICAL OUTER RING WITHOUT SEALS	JNS NUMBER CROWNED OUTER RING WITHOUT SEALS	JNS NUMBER CYLINDRICAL OUTER RING WITH SEALS	JNS NUMBER CROWNED OUTER RING WITH SEALS	Mass (Approx.) g	Dimensions(mm)						Basic dynamic load rating Cr N	Basic static load rating Cor N
					d	D	C	G	B1	C1		
CFH5A	CFH5RA	CFH5UUA	CFH5UURA	10.5	5	13	9	M5×0.8	23	0.5	3 140	2 770
CFH5VA	CFH5VRA	CFH5VUUA	CFH5VUURA	10.5	5	13	9	M5×0.8	23	0.5	5 100	5 500
CFH6A	CFH6RA	CFH6UUA	CFH6UURA	18.5	6	16	11	M6×1	28	0.6	3 630	3 630
CFH6VA	CFH6VRA	CFH6VUUA	CFH6VUURA	18.5	6	16	11	M6×1	28	0.6	6 960	8 530
CFH8A	CFH8RA	CFH8UUA	CFH8UURA	28.5	8	19	11	M8×1.25	32	0.6	4 310	4 710
CFH8VA	CFH8VRA	CFH8VUUA	CFH8VUURA	28.5	8	19	11	M8×1.25	32	0.6	8 130	11 170
CFH10A	CFH10RA	CFH10UUA	CFH10UURA	45	10	22	12	M10×1.25	36	0.6	5 390	6 860
CFH10VA	CFH10VRA	CFH10VUUA	CFH10VUURA	45	10	22	12	M10×1.25	36	0.6	9 510	14 500
CFH10-1A	CFH10-1RA	CFH10-1UUA	CFH10-1UURA	60	10	26	12	M10×1.25	36	0.6	5 390	6 860
CFH10-1VA	CFH10-1VRA	CFH10-1VUUA	CFH10-1VUURA	60	10	26	12	M10×1.25	36	0.6	9 510	14 500
CFH12A	CFH12RA	CFH12UUA	CFH12UURA	95	12	30	14	M12×1.5	40	0.6	7 940	9 800
CFH12VA	CFH12VRA	CFH12VUUA	CFH12VUURA	95	12	30	14	M12×1.5	40	0.6	13 430	19 700
CFH12-1A	CFH12-1RA	CFH12-1UUA	CFH12-1UURA	105	12	32	14	M12×1.5	40	0.6	7 940	9 800
CFH12-1VA	CFH12-1VRA	CFH12-1VUUA	CFH12-1VUURA	105	12	32	14	M12×1.5	40	0.6	13 430	19 700
CFH16A	CFH16RA	CFH16UUA	CFH16UURA	170	16	35	18	M16×1.5	52	0.8	12 050	18 330
CFH16VA	CFH16VRA	CFH16VUUA	CFH16VUURA	170	16	35	18	M16×1.5	52	0.8	20 680	37 630
CFH18A	CFH18RA	CFH18UUA	CFH18UURA	250	18	40	20	M18×1.5	58	0.8	14 700	25 200
CFH18VA	CFH18VRA	CFH18VUUA	CFH18VUURA	250	18	40	20	M18×1.5	58	0.8	25 280	51 350
CFH20A	CFH20RA	CFH20UUA	CFH20UURA	460	20	52	24	M20×1.5	66	0.8	20 680	34 600
CFH20VA	CFH20VRA	CFH20VUUA	CFH20VUURA	460	20	52	24	M20×1.5	66	0.8	33 120	64 480
CFH20-1A	CFH20-1RA	CFH20-1UUA	CFH20-1UURA	385	20	47	24	M20×1.5	66	0.8	20 680	34 600
CFH20-1VA	CFH20-1VRA	CFH20-1VUUA	CFH20-1VUURA	385	20	47	24	M20×1.5	66	0.8	33 120	64 480
CFH24A	CFH24RA	CFH24UUA	CFH24UURA	815	24	62	29	M24×1.5	80	0.8	30 480	52 630
CFH24VA	CFH24VRA	CFH24VUUA	CFH24VUURA	815	24	62	29	M24×1.5	80	0.8	46 550	92 020
CFH24-1A	CFH24-1RA	CFH24-1UUA	CFH24-1UURA	1 140	24	72	29	M24×1.5	80	0.8	30 480	52 630
CFH24-1VA	CFH24-1VRA	CFH24-1VUUA	CFH24-1VUURA	1 140	24	72	29	M24×1.5	80	0.8	46 550	92 020
CFH30A	CFH30RA	CFH30UUA	CFH30UURA	1 870	30	80	35	M30×1.5	100	1	45 370	85 060
CFH30VA	CFH30VRA	CFH30VUUA	CFH30VUURA	1 870	30	80	35	M30×1.5	100	1	67 620	144 060
CFH30-1A	CFH30-1RA	CFH30-1UUA	CFH30-1UURA	2 030	30	85	35	M30×1.5	100	1	45 370	85 060
CFH30-1VA	CFH30-1VRA	CFH30-1VUUA	CFH30-1VUURA	2 030	30	85	35	M30×1.5	100	1	67 620	144 060
CFH30-2A	CFH30-2RA	CFH30-2UUA	CFH30-2UURA	2 220	30	90	35	M30×1.5	100	1	45 370	85 060
CFH30-2VA	CFH30-2VRA	CFH30-2VUUA	CFH30-2VUURA	2 220	30	90	35	M30×1.5	100	1	67 620	144 060

Stud diameter (d) 5 to 10mm : No grease refilling hole is provided



INTERCHANGE

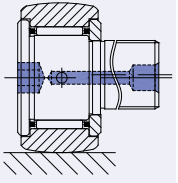

CFH. . RA

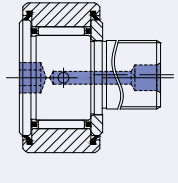

CFH. . UUA

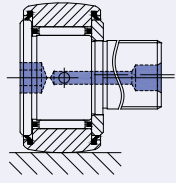

CFH. . UURA

INTERCHANGE TABLE

INA		NTN		IKO				MCGILL	
CYLINDRICAL OUTER RING WITHOUT SEALS	CROWNED OUTER RING WITHOUT SEALS	CYLINDRICAL OUTER RING WITHOUT SEALS	CROWNED OUTER RING WITHOUT SEALS	CYLINDRICAL OUTER RING WITH SEALS	CROWNED OUTER RING WITH SEALS	CYLINDRICAL OUTER RING WITHOUT SEALS	CROWNED OUTER RING WITHOUT SEALS	CYLINDRICAL OUTER RING WITHOUT SEALS	CROWNED OUTER RING WITHOUT SEALS
—	—	—	—	CFES-B	CFES-BR	CFES-BUU	CFES-BUUR	—	—
—	—	—	—	—	—	—	—	—	—
—	—	—	—	—	—	—	—	—	—
—	—	—	—	—	—	—	—	—	—
—	—	—	—	CFES6B	CFES6BR	CFES6BUU	CFES6BUUR	—	—
—	—	—	—	—	—	—	—	—	—
—	—	—	—	CFES8B	CFES8BR	CFES8BUU	CFES8BUUR	—	—
—	—	—	—	—	—	—	—	—	—
—	—	—	—	CFES10B	CFES10BR	CFES10BUU	CFES10BUUR	—	—
—	—	—	—	—	—	—	—	—	—
—	—	—	—	CFES10-1B	CFES10-1BR	CFES10-1BUU	CFES10-1BUUR	—	—
—	—	—	—	—	—	—	—	—	—
—	—	—	—	CFES12B	CFES12BR	CFES12BUU	CFES12BUUR	—	—
—	—	—	—	—	—	—	—	—	—
—	—	—	—	CFES12-1B	CFES12-1BR	CFES12-1BUU	CFES12-1BUUR	—	—
—	—	—	—	—	—	—	—	—	—
—	—	—	—	CFES16B	CFES16BR	CFES16BUU	CFES16BUUR	—	—
—	—	—	—	—	—	—	—	—	—
—	—	—	—	CFES18B	CFES18BR	CFES18BUU	CFES18BUUR	—	—
—	—	—	—	—	—	—	—	—	—
—	—	—	—	—	—	—	—	—	—
—	—	—	—	—	—	—	—	—	—
—	—	—	—	—	—	—	—	—	—
—	—	—	—	—	—	—	—	—	—
—	—	—	—	—	—	—	—	—	—
—	—	—	—	—	—	—	—	—	—
—	—	—	—	—	—	—	—	—	—
—	—	—	—	—	—	—	—	—	—
—	—	—	—	—	—	—	—	—	—
—	—	—	—	—	—	—	—	—	—
—	—	—	—	—	—	—	—	—	—
—	—	—	—	—	—	—	—	—	—
—	—	—	—	—	—	—	—	—	—
—	—	—	—	—	—	—	—	—	—
—	—	—	—	—	—	—	—	—	—
—	—	—	—	—	—	—	—	—	—
—	—	—	—	—	—	—	—	—	—
—	—	—	—	—	—	—	—	—	—
—	—	—	—	—	—	—	—	—	—
—	—	—	—	—	—	—	—	—	—
—	—	—	—	—	—	—	—	—	—
—	—	—	—	—	—	—	—	—	—
—	—	—	—	—	—	—	—	—	—
—	—	—	—	—	—	—	—	—	—
—	—	—	—	—	—	—	—	—	—



INTERCHANGE

CAM FOLLOWERS

SOLID ECCENTRIC TYPE
HEXAGON SOCKET ON BOTH SIDES
GREASE NIPPLE INSTALLED

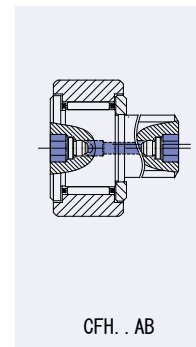
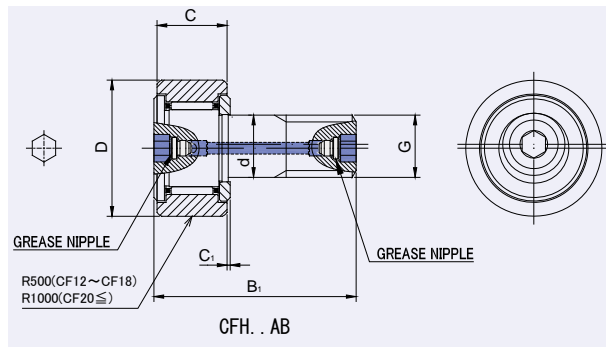

CFH..AB, RAB, UUAB, UURAB

DIMENSION TABLE

JNS NUMBER CYLINDRICAL OUTER RING WITHOUT SEALS	JNS NUMBER CROWNED OUTER RING WITHOUT SEALS	JNS NUMBER CYLINDRICAL OUTER RING WITH SEALS	JNS NUMBER CROWNED OUTER RING WITH SEALS	Mass (Approx.) g	Dimensions(mm)						Basic dynamic load rating Cr N	Basic static load rating Cor N
					d	D	C	G	B1	C1		
CFH12AB	CFH12RAB	CFH12UUAB	CFH12UURAB	95	12	30	14	M12×1.5	40	0.6	7 940	9 800
CFH12VAB	CFH12VRAB	CFH12VUUAB	CFH12VUURAB	95	12	30	14	M12×1.5	40	0.6	13 430	19 700
CFH12-1AB	CFH12-1RAB	CFH12-1UUAB	CFH12-1UURAB	105	12	32	14	M12×1.5	40	0.6	7 940	9 800
CFH12-1VAB	CFH12-1VRAB	CFH12-1VUUAB	CFH12-1VUURAB	105	12	32	14	M12×1.5	40	0.6	13 430	19 700
CFH16AB	CFH16RAB	CFH16UUAB	CFH16UURAB	170	16	35	18	M16×1.5	52	0.8	12 050	18 330
CFH16VAB	CFH16VRAB	CFH16VUUAB	CFH16VUURAB	170	16	35	18	M16×1.5	52	0.8	20 680	37 630
CFH18AB	CFH18RAB	CFH18UUAB	CFH18UURAB	250	18	40	20	M18×1.5	58	0.8	14 700	25 200
CFH18VAB	CFH18VRAB	CFH18VUUAB	CFH18VUURAB	250	18	40	20	M18×1.5	58	0.8	25 280	51 350
CFH20AB	CFH20RAB	CFH20UUAB	CFH20UURAB	460	20	52	24	M20×1.5	66	0.8	20 680	34 600
CFH20VAB	CFH20VRAB	CFH20VUUAB	CFH20VUURAB	460	20	52	24	M20×1.5	66	0.8	33 120	64 480
CFH20-1AB	CFH20-1RAB	CFH20-1UUAB	CFH20-1UURAB	385	20	47	24	M20×1.5	66	0.8	20 680	34 600
CFH20-1VAB	CFH20-1VRAB	CFH20-1VUUAB	CFH20-1VUURAB	385	20	47	24	M20×1.5	66	0.8	33 120	64 480
CFH24AB	CFH24RAB	CFH24UUAB	CFH24UURAB	815	24	62	29	M24×1.5	80	0.8	30 480	52 630
CFH24VAB	CFH24VRAB	CFH24VUUAB	CFH24VUURAB	815	24	62	29	M24×1.5	80	0.8	46 550	92 020
CFH24-1AB	CFH24-1RAB	CFH24-1UUAB	CFH24-1UURAB	1 140	24	72	29	M24×1.5	80	0.8	30 480	52 630
CFH24-1VAB	CFH24-1VRAB	CFH24-1VUUAB	CFH24-1VUURAB	1 140	24	72	29	M24×1.5	80	0.8	46 550	92 020
CFH30AB	CFH30RAB	CFH30UUAB	CFH30UURAB	1 870	30	80	35	M30×1.5	100	1	45 370	85 060
CFH30VAB	CFH30VRAB	CFH30VUUAB	CFH30VUURAB	1 870	30	80	35	M30×1.5	100	1	67 620	144 060
CFH30-1AB	CFH30-1RAB	CFH30-1UUAB	CFH30-1UURAB	2 030	30	85	35	M30×1.5	100	1	45 370	85 060
CFH30-1VAB	CFH30-1VRAB	CFH30-1VUUAB	CFH30-1VUURAB	2 030	30	85	35	M30×1.5	100	1	67 620	144 060
CFH30-2AB	CFH30-2RAB	CFH30-2UUAB	CFH30-2UURAB	2 220	30	90	35	M30×1.5	100	1	45 370	85 060
CFH30-2VAB	CFH30-2VRAB	CFH30-2VUUAB	CFH30-2VUURAB	2 220	30	90	35	M30×1.5	100	1	67 620	144 060



INTERCHANGE

CAM FOLLOWERS

SOLID ECCENTRIC TYPE SCREWDRIVER SLOT HEAD

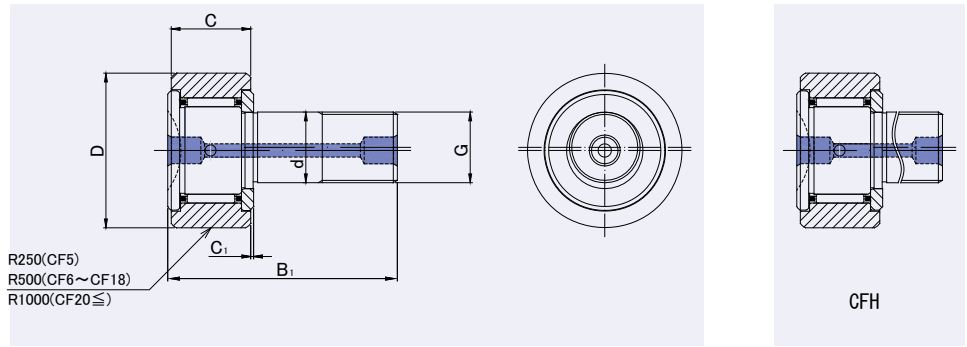

CFH, R, UU, UUR

DIMENSION TABLE

JNS NUMBER CYLINDRICAL OUTER RING WITHOUT SEALS	JNS NUMBER CROWNED OUTER RING WITHOUT SEALS	JNS NUMBER CYLINDRICAL OUTER RING WITH SEALS	JNS NUMBER CROWNED OUTER RING WITH SEALS	Mass (Approx.) g	Dimensions(mm)						Basic dynamic load rating Cr N	Basic static load rating Cor N	INA	
					d	D	C	G	B1	C1			CYLINDRICAL OUTER RING WITHOUT SEALS	
CFH	CFH..R	CFH..UU	CFH..UUR		d	D	C	G	B1	C1			—	
CFH5	CFH5R	CFH5UU	CFH5UUR	10.5	5	13	9	M5×0.8	23	0.5	3 140	2 770	—	
CFH5V	CFH5VR	CFH5VUU	CFH5VUUR	10.5	5	13	9	M5×0.8	23	0.5	5 100	5 500	—	
CFH6	CFH6R	CFH6UU	CFH6UUR	18.5	6	16	11	M6×1	28	0.6	3 630	3 630	—	
CFH6V	CFH6VR	CFH6VUU	CFH6VUUR	18.5	6	16	11	M6×1	28	0.6	6 960	8 530	—	
CFH8	CFH8R	CFH8UU	CFH8UUR	28.5	8	19	11	M8×1.25	32	0.6	4 310	4 710	—	
CFH8V	CFH8VR	CFH8VUU	CFH8VUUR	28.5	8	19	11	M8×1.25	32	0.6	8 130	11 170	—	
CFH10	CFH10R	CFH10UU	CFH10UUR	45	10	22	12	M10×1.25	36	0.6	5 390	6 860	—	
CFH10V	CFH10VR	CFH10VUU	CFH10VUUR	45	10	22	12	M10×1.25	36	0.6	9 510	14 500	—	
CFH10-1	CFH10-1R	CFH10-1UU	CFH10-1UUR	60	10	26	12	M10×1.25	36	0.6	5 390	6 860	—	
CFH10-1V	CFH10-1VR	CFH10-1VUU	CFH10-1VUUR	60	10	26	12	M10×1.25	36	0.6	9 510	14 500	—	
CFH12	CFH12R	CFH12UU	CFH12UUR	95	12	30	14	M12×1.5	40	0.6	7 940	9 800	—	
CFH12V	CFH12VR	CFH12VUU	CFH12VUUR	95	12	30	14	M12×1.5	40	0.6	13 430	19 700	—	
CFH12-1	CFH12-1R	CFH12-1UU	CFH12-1UUR	105	12	32	14	M12×1.5	40	0.6	7 940	9 800	—	
CFH12-1V	CFH12-1VR	CFH12-1VUU	CFH12-1VUUR	105	12	32	14	M12×1.5	40	0.6	13 430	19 700	—	
CFH16	CFH16R	CFH16UU	CFH16UUR	170	16	35	18	M16×1.5	52	0.8	12 050	18 330	—	
CFH16V	CFH16VR	CFH16VUU	CFH16VUUR	170	16	35	18	M16×1.5	52	0.8	20 680	37 630	—	
CFH18	CFH18R	CFH18UU	CFH18UUR	250	18	40	20	M18×1.5	58	0.8	14 700	25 200	—	
CFH18V	CFH18VR	CFH18VUU	CFH18VUUR	250	18	40	20	M18×1.5	58	0.8	25 280	51 350	—	
CFH20	CFH20R	CFH20UU	CFH20UUR	460	20	52	24	M20×1.5	66	0.8	20 680	34 600	—	
CFH20V	CFH20VR	CFH20VUU	CFH20VUUR	460	20	52	24	M20×1.5	66	0.8	33 120	64 480	—	
CFH20-1	CFH20-1R	CFH20-1UU	CFH20-1UUR	385	20	47	24	M20×1.5	66	0.8	20 680	34 600	—	
CFH20-1V	CFH20-1VR	CFH20-1VUU	CFH20-1VUUR	385	20	47	24	M20×1.5	66	0.8	33 120	64 480	—	
CFH24	CFH24R	CFH24UU	CFH24UUR	815	24	62	29	M24×1.5	80	0.8	30 480	52 630	—	
CFH24V	CFH24VR	CFH24VUU	CFH24VUUR	815	24	62	29	M24×1.5	80	0.8	46 550	92 020	—	
CFH24-1	CFH24-1R	CFH24-1UU	CFH24-1UUR	1 140	24	72	29	M24×1.5	80	0.8	30 480	52 630	—	
CFH24-1V	CFH24-1VR	CFH24-1VUU	CFH24-1VUUR	1 140	24	72	29	M24×1.5	80	0.8	46 550	92 020	—	
CFH30	CFH30R	CFH30UU	CFH30UUR	1 870	30	80	35	M30×1.5	100	1	45 370	85 060	—	
CFH30V	CFH30VR	CFH30VUU	CFH30VUUR	1 870	30	80	35	M30×1.5	100	1	67 620	144 060	—	
CFH30-1	CFH30-1R	CFH30-1UU	CFH30-1UUR	2 030	30	85	35	M30×1.5	100	1	45 370	85 060	—	
CFH30-1V	CFH30-1VR	CFH30-1VUU	CFH30-1VUUR	2 030	30	85	35	M30×1.5	100	1	67 620	144 060	—	
CFH30-2	CFH30-2R	CFH30-2UU	CFH30-2UUR	2 220	30	90	35	M30×1.5	100	1	45 370	85 060	—	
CFH30-2V	CFH30-2VR	CFH30-2VUU	CFH30-2VUUR	2 220	30	90	35	M30×1.5	100	1	67 620	144 060	—	

Stud diameter (d) 5 to 10mm : Without oil hole in the thread side.



INTERCHANGE

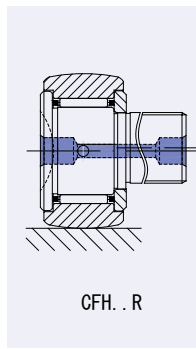

CFH. . R

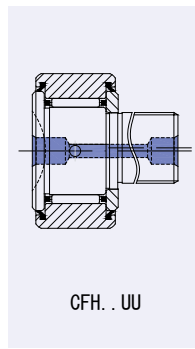

CFH. . UU

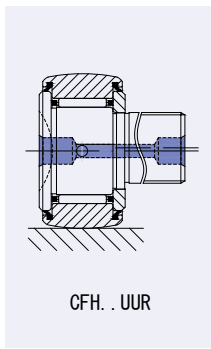

CFH. . UUR

INTERCHANGE TABLE

CROWNED OUTER RING WITHOUT SEALS	NTN				IKO				MCGILL	
	CYLINDRICAL OUTER RING WITHOUT SEALS	CROWNED OUTER RING WITHOUT SEALS	CYLINDRICAL OUTER RING WITH SEALS	CROWNED OUTER RING WITH SEALS	CYLINDRICAL OUTER RING WITHOUT SEALS	CROWNED OUTER RING WITHOUT SEALS	CYLINDRICAL OUTER RING WITH SEALS	CROWNED OUTER RING WITH SEALS	CYLINDRICAL OUTER RING WITHOUT SEALS	CROWNED OUTER RING WITHOUT SEALS
—	KRU..X	KRU	KRU..LLX	KRU..LL	CFES	CFES..R	CFES-UU	CFES-UUR	—	—
—	—	—	—	—	—	—	—	—	—	—
—	—	—	—	—	—	—	—	—	—	—
—	KRU16X	KRU16	KRU16LLX/3AS	KRU16LL/3AS/3AS	CFES6	CFES6R	CFES6UU	CFES6UUR	—	—
—	—	—	—	—	—	—	—	—	—	—
—	KRU19X	KRU19	KRU19LLX/3AS	KRU19LL/3AS/3AS	CFES8	CFES8R	CFES8UU	CFES8UUR	—	—
—	—	—	—	—	—	—	—	—	—	—
—	KRU22X	KRU22	KRU22LLX/3AS	KRU22LL/3AS/3AS	CFES10	CFES10R	CFES10UU	CFES10UUR	—	—
—	—	—	—	—	—	—	—	—	—	—
—	KRU26X	KRU26	KRU26LLX/3AS	KRU26LL/3AS/3AS	CFES10-1	CFES10-1R	CFES10-1UU	CFES10-1UUR	—	—
—	—	—	—	—	—	—	—	—	—	—
—	KRU30X	KRU30	KRU30LLX/3AS	KRU30LL/3AS/3AS	CFES12	CFES12R	CFES12UU	CFES12UUR	—	—
—	—	—	—	—	—	—	—	—	—	—
—	KRU32X	KRU32	KRU32LLX/3AS	KRU32LL/3AS/3AS	CFES12-1	CFES12-1R	CFES12-1UU	CFES12-1UUR	—	—
—	—	—	—	—	—	—	—	—	—	—
—	KRU35X	KRU35	KRU35LLX/3AS	KRU35LL/3AS/3AS	CFES16	CFES16R	CFES16UU	CFES16UUR	—	—
—	—	—	—	—	—	—	—	—	—	—
—	KRU40X	KRU40	KRU40LLX/3AS	KRU40LL/3AS/3AS	CFES18	CFES18R	CFES18UU	CFES18UUR	—	—
—	—	—	—	—	—	—	—	—	—	—
—	KRU52X	KRU52	KRU52LLX/3AS	KRU52LL/3AS/3AS	—	—	—	—	—	—
—	—	—	—	—	—	—	—	—	—	—
—	KRU47X	KRU47	KRU47LLX/3AS	KRU47LL/3AS/3AS	—	—	—	—	—	—
—	—	—	—	—	—	—	—	—	—	—
—	KRU62X	KRU62	KRU62LLX/3AS	KRU62LL/3AS/3AS	—	—	—	—	—	—
—	—	—	—	—	—	—	—	—	—	—
—	KRU72X	KRU72	KRU72LLX/3AS	KRU72LL/3AS/3AS	—	—	—	—	—	—
—	—	—	—	—	—	—	—	—	—	—
—	KRU80X	KRU80	KRU80LLX/3AS	KRU80LL/3AS/3AS	—	—	—	—	—	—
—	—	—	—	—	—	—	—	—	—	—
—	—	—	—	—	—	—	—	—	—	—
—	—	—	—	—	—	—	—	—	—	—
—	KRU90X	KRU90	KRU90LLX/3AS	KRU90LL/3AS/3AS	—	—	—	—	—	—
—	—	—	—	—	—	—	—	—	—	—



INTERCHANGE

CAM FOLLOWERS

TAP HOLE FOR PIPING SCREWDRIVER SLOT HEAD

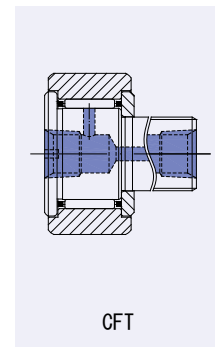
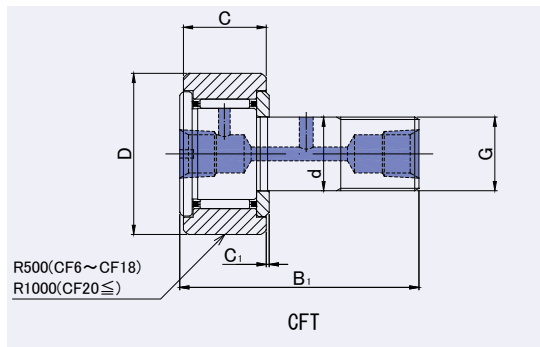

CFT, R, UU, UUR

DIMENSION TABLE

JNS NUMBER CYLINDRICAL OUTER RING WITHOUT SEALS	JNS NUMBER CROWNED OUTER RING WITHOUT SEALS	JNS NUMBER CYLINDRICAL OUTER RING WITH SEALS	JNS NUMBER CROWNED OUTER RING WITH SEALS	Mass (Approx.) g	Dimensions(mm)						Basic dynamic load rating Cr N	Basic static load rating Cor N
					d	D	C	G	B1	C1		
CFT	CFT..R	CFT..UU	CFT..UUR		d	D	C	G	B1	C1		
CFT6	CFT6R	CFT6UU	CFT6UUR	18.5	6	16	11	M6×1	28	0.6	3 630	3 630
CFT6V	CFT6VR	CFT6VUU	CFT6VUUR	18.5	6	16	11	M6×1	28	0.6	6 960	8 530
CFT8	CFT8R	CFT8UU	CFT8UUR	28.5	8	19	11	M8×1.25	32	0.6	4 310	4 710
CFT8V	CFT8VR	CFT8VUU	CFT8VUUR	28.5	8	19	11	M8×1.25	32	0.6	8 130	11 170
CFT10	CFT10R	CFT10UU	CFT10UUR	45	10	22	12	M10×1.25	36	0.6	5 390	6 860
CFT10V	CFT10VR	CFT10VUU	CFT10VUUR	45	10	22	12	M10×1.25	36	0.6	9 510	14 500
CFT10-1	CFT10-1R	CFT10-1UU	CFT10-1UUR	60	10	26	12	M10×1.25	36	0.6	5 390	6 860
CFT10-1V	CFT10-1VR	CFT10-1VUU	CFT10-1VUUR	60	10	26	12	M10×1.25	36	0.6	9 510	14 500
CFT12	CFT12R	CFT12UU	CFT12UUR	95	12	30	14	M12×1.5	40	0.6	7 940	9 800
CFT12V	CFT12VR	CFT12VUU	CFT12VUUR	95	12	30	14	M12×1.5	40	0.6	13 430	19 700
CFT12-1	CFT12-1R	CFT12-1UU	CFT12-1UUR	105	12	32	14	M12×1.5	40	0.6	7 940	9 800
CFT12-1V	CFT12-1VR	CFT12-1VUU	CFT12-1VUUR	105	12	32	14	M12×1.5	40	0.6	13 430	19 700
CFT16	CFT16R	CFT16UU	CFT16UUR	170	16	35	18	M16×1.5	52	0.8	12 050	18 330
CFT16V	CFT16VR	CFT16VUU	CFT16VUUR	170	16	35	18	M16×1.5	52	0.8	20 680	37 630
CFT18	CFT18R	CFT18UU	CFT18UUR	250	18	40	20	M18×1.5	58	0.8	14 700	25 200
CFT18V	CFT18VR	CFT18VUU	CFT18VUUR	250	18	40	20	M18×1.5	58	0.8	25 280	51 350
CFT20	CFT20R	CFT20UU	CFT20UUR	460	20	52	24	M20×1.5	66	0.8	20 680	34 600
CFT20V	CFT20VR	CFT20VUU	CFT20VUUR	460	20	52	24	M20×1.5	66	0.8	33 120	64 480
CFT20-1	CFT20-1R	CFT20-1UU	CFT20-1UUR	385	20	47	24	M20×1.5	66	0.8	20 680	34 600
CFT20-1V	CFT20-1VR	CFT20-1VUU	CFT20-1VUUR	385	20	47	24	M20×1.5	66	0.8	33 120	64 480
CFT24	CFT24R	CFT24UU	CFT24UUR	815	24	62	29	M24×1.5	80	0.8	30 480	52 630
CFT24V	CFT24VR	CFT24VUU	CFT24VUUR	815	24	62	29	M24×1.5	80	0.8	46 550	92 020
CFT24-1	CFT24-1R	CFT24-1UU	CFT24-1UUR	1 140	24	72	29	M24×1.5	80	0.8	30 480	52 630
CFT24-1V	CFT24-1VR	CFT24-1VUU	CFT24-1VUUR	1 140	24	72	29	M24×1.5	80	0.8	46 550	92 020
CFT30	CFT30R	CFT30UU	CFT30UUR	1 870	30	80	35	M30×1.5	100	1	45 370	85 060
CFT30V	CFT30VR	CFT30VUU	CFT30VUUR	1 870	30	80	35	M30×1.5	100	1	67 620	144 060
CFT30-1	CFT30-1R	CFT30-1UU	CFT30-1UUR	2 030	30	85	35	M30×1.5	100	1	45 370	85 060
CFT30-1V	CFT30-1VR	CFT30-1VUU	CFT30-1VUUR	2 030	30	85	35	M30×1.5	100	1	67 620	144 060
CFT30-2	CFT30-2R	CFT30-2UU	CFT30-2UUR	2 220	30	90	35	M30×1.5	100	1	45 370	85 060
CFT30-2V	CFT30-2VR	CFT30-2VUU	CFT30-2VUUR	2 220	30	90	35	M30×1.5	100	1	67 620	144 060

Stud diameter (d) 6 to 10mm : Without oil hole in the thread side.



INTERCHANGE

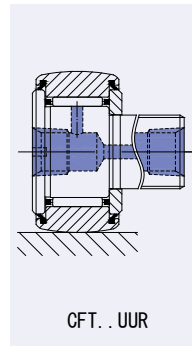
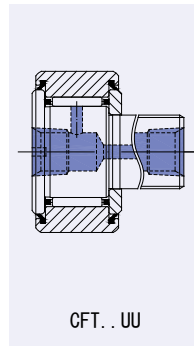
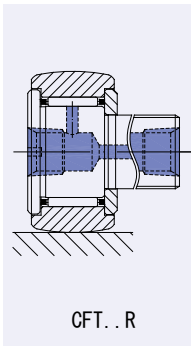

INTERCHANGE TABLE

INA		NTN				IKO				MCGILL	
CYLINDRICAL OUTER RING WITHOUT SEALS	CROWNED OUTER RING WITHOUT SEALS	CYLINDRICAL OUTER RING WITHOUT SEALS	CROWNED OUTER RING WITHOUT SEALS	CYLINDRICAL OUTER RING WITH SEALS	CROWNED OUTER RING WITH SEALS	CYLINDRICAL OUTER RING WITHOUT SEALS	CROWNED OUTER RING WITHOUT SEALS	CYLINDRICAL OUTER RING WITH SEALS	CROWNED OUTER RING WITH SEALS	CYLINDRICAL OUTER RING WITHOUT SEALS	CROWNED OUTER RING WITHOUT SEALS
—	—	KRT-X	KRT	KRT-XLL	KRT-LL	—	—	CF-FU1	CF-RU1	—	—
—	—	KRT16X	KRT16	KRT16XLL	KRT16LL	—	—	CF-FU1-6	CF-RU1-6	—	—
—	—	KRVT16X	KRVT16	KRVT16XLL	KRVT16LL	—	—	—	—	—	—
—	—	KRT19X	KRT19	KRT19XLL	KRT19LL	—	—	CF-FU1-8	CF-RU1-8	—	—
—	—	KRVT19X	KRVT19	KRVT19XLL	KRVT19LL	—	—	—	—	—	—
—	—	KRT22X	KRT22	KRT22XLL	KRT22LL	—	—	CF-FU1-10	CF-RU1-10	—	—
—	—	KRVT22X	KRVT22	KRVT22XLL	KRVT22LL	—	—	—	—	—	—
—	—	KRT26X	KRT26	KRT26XLL	KRT26LL	—	—	CF-FU1-10-1	CF-RU1-10-1	—	—
—	—	KRVT26X	KRVT26	KRVT26XLL	KRVT26LL	—	—	—	—	—	—
—	—	KRT30X	KRT30	KRT30XLL	KRT30LL	—	—	CF-FU1-12	CF-RU1-12	—	—
—	—	KRVT30X	KRVT30	KRVT30XLL	KRVT30LL	—	—	—	—	—	—
—	—	KRT32X	KRT32	KRT32XLL	KRT32LL	—	—	CF-FU1-12-1	CF-RU1-12-1	—	—
—	—	KRVT32X	KRVT32	KRVT32XLL	KRVT32LL	—	—	—	—	—	—
—	—	KRT35X	KRT35	KRT35XLL	KRT35LL	—	—	CF-FU1-16	CF-RU1-16	—	—
—	—	KRVT35X	KRVT35	KRVT35XLL	KRVT35LL	—	—	—	—	—	—
—	—	KRT40X	KRT40	KRT40XLL	KRT40LL	—	—	CF-FU1-18	CF-RU1-18	—	—
—	—	KRVT40X	KRVT40	KRVT40XLL	KRVT40LL	—	—	—	—	—	—
—	—	KRT52X	KRT52	KRT52XLL	KRT52LL	—	—	CF-FU1-20	CF-RU1-20	—	—
—	—	KRVT52X	KRVT52	KRVT52XLL	KRVT52LL	—	—	—	—	—	—
—	—	KRT47X	KRT47	KRT47XLL	KRT47LL	—	—	CF-FU1-20-1	CF-RU1-20-1	—	—
—	—	KRVT47X	KRVT47	KRVT47XLL	KRVT47LL	—	—	—	—	—	—
—	—	KRT62X	KRT62	KRT62XLL	KRT62LL	—	—	CF-FU1-24	CF-RU1-24	—	—
—	—	KRVT62X	KRVT62	KRVT62XLL	KRVT62LL	—	—	—	—	—	—
—	—	KRT72X	KRT72	KRT72XLL	KRT72LL	—	—	CF-FU1-24-1	CF-RU1-24-1	—	—
—	—	KRVT72X	KRVT72	KRVT72XLL	KRVT72LL	—	—	—	—	—	—
—	—	KRT80X	KRT80	KRT80XLL	KRT80LL	—	—	CF-FU1-30	CF-RU1-30	—	—
—	—	KRVT80X	KRVT80	KRVT80XLL	KRVT80LL	—	—	—	—	—	—
—	—	KRT85X	KRT85	KRT85XLL	KRT85LL	—	—	CF-FU1-30-1	CF-RU1-30-1	—	—
—	—	—	—	—	—	—	—	—	—	—	—
—	—	KRT90X	KRT90	KRT90XLL	KRT90LL	—	—	CF-FU1-30-2	CF-RU1-30-2	—	—
—	—	KRVT90X	KRVT90	KRVT90XLL	KRVT90LL	—	—	—	—	—	—



INTERCHANGE

CAM FOLLOWERS

TAP HOLE FOR PIPING
HEXAGON SOCKET ON STUD HEAD

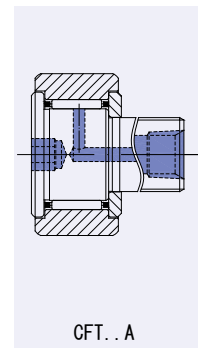
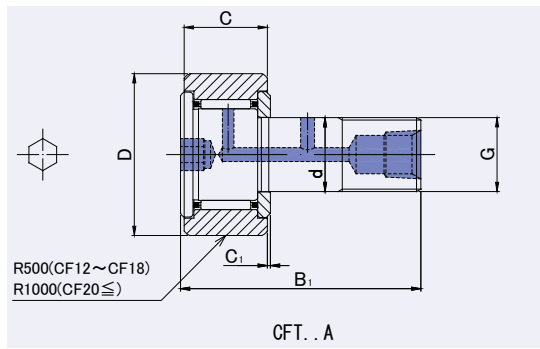

CFT..A, RA, UUA, UURA

DIMENSION TABLE

JNS NUMBER CYLINDRICAL OUTER RING WITHOUT SEALS	JNS NUMBER CROWNED OUTER RING WITHOUT SEALS	JNS NUMBER CYLINDRICAL OUTER RING WITH SEALS	JNS NUMBER CROWNED OUTER RING WITH SEALS	Mass (Approx.) g	Dimensions(mm)						Basic dynamic load rating Cr N	Basic static load rating Cor N
					d	D	C	G	B1	C1		
CFT12A	CFT12RA	CFT12UUA	CFT12UURA	95	12	30	14	M12×1.5	40	0.6	7 940	9 800
CFT12VA	CFT12VRA	CFT12VUUA	CFT12VUURA	95	12	30	14	M12×1.5	40	0.6	13 430	19 700
CFT12-1A	CFT12-1RA	CFT12-1UUA	CFT12-1UURA	105	12	32	14	M12×1.5	40	0.6	7 940	9 800
CFT12-1VA	CFT12-1VRA	CFT12-1VUUA	CFT12-1VUURA	105	12	32	14	M12×1.5	40	0.6	13 430	19 700
CFT16A	CFT16RA	CFT16UUA	CFT16UURA	170	16	35	18	M16×1.5	52	0.8	12 050	18 330
CFT16VA	CFT16VRA	CFT16VUUA	CFT16VUURA	170	16	35	18	M16×1.5	52	0.8	20 680	37 630
CFT18A	CFT18RA	CFT18UUA	CFT18UURA	250	18	40	20	M18×1.5	58	0.8	14 700	25 200
CFT18VA	CFT18VRA	CFT18VUUA	CFT18VUURA	250	18	40	20	M18×1.5	58	0.8	25 280	51 350
CFT20A	CFT20RA	CFT20UUA	CFT20UURA	460	20	52	24	M20×1.5	66	0.8	20 680	34 600
CFT20VA	CFT20VRA	CFT20VUUA	CFT20VUURA	460	20	52	24	M20×1.5	66	0.8	33 120	64 480
CFT20-1A	CFT20-1RA	CFT20-1UUA	CFT20-1UURA	385	20	47	24	M20×1.5	66	0.8	20 680	34 600
CFT20-1VA	CFT20-1VRA	CFT20-1VUUA	CFT20-1VUURA	385	20	47	24	M20×1.5	66	0.8	33 120	64 480
CFT24A	CFT24RA	CFT24UUA	CFT24UURA	815	24	62	29	M24×1.5	80	0.8	30 480	52 630
CFT24VA	CFT24VRA	CFT24VUUA	CFT24VUURA	815	24	62	29	M24×1.5	80	0.8	46 550	92 020
CFT24-1A	CFT24-1RA	CFT24-1UUA	CFT24-1UURA	1 140	24	72	29	M24×1.5	80	0.8	30 480	52 630
CFT24-1VA	CFT24-1VRA	CFT24-1VUUA	CFT24-1VUURA	1 140	24	72	29	M24×1.5	80	0.8	46 550	92 020
CFT30A	CFT30RA	CFT30UUA	CFT30UURA	1 870	30	80	35	M30×1.5	100	1	45 370	85 060
CFT30VA	CFT30VRA	CFT30VUUA	CFT30VUURA	1 870	30	80	35	M30×1.5	100	1	67 620	144 060
CFT30-1A	CFT30-1RA	CFT30-1UUA	CFT30-1UURA	2 030	30	85	35	M30×1.5	100	1	45 370	85 060
CFT30-1VA	CFT30-1VRA	CFT30-1VUUA	CFT30-1VUURA	2 030	30	85	35	M30×1.5	100	1	67 620	144 060
CFT30-2A	CFT30-2RA	CFT30-2UUA	CFT30-2UURA	2 220	30	90	35	M30×1.5	100	1	45 370	85 060
CFT30-2VA	CFT30-2VRA	CFT30-2VUUA	CFT30-2VUURA	2 220	30	90	35	M30×1.5	100	1	67 620	144 060



INTERCHANGE

ROLLER FOLLOWERS

SEPARABLE WITHOUT INNER RING

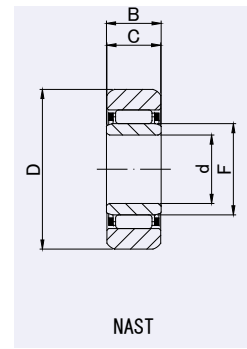
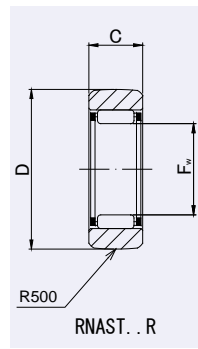
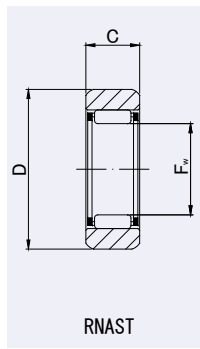

RNAS, RNAS..R, NAS, NAS..R

DIMENSION TABLE

INTERCHANGE TABLE

JNS NUMBER CYLINDRICAL OUTER RING	JNS NUMBER CROWNED OUTER RING	Weight	JNS	JNS	Weight	Dimensions(mm)					Basic dynamic load rating	Basic static load rating	INA			
			NUMBER CYLINDRICAL OUTER RING WITH INNER RING	NUMBER CROWNED OUTER RING WITH INNER RING		Fw (F)	D	d	C	B			Cr N	Cor N	CYLINDRICAL OUTER RING WITHOUT INNER RING	CROWNED OUTER RING WITHOUT INNER RING
RNAS	RNAS..R	g	NAS	NAS..R	g									RSTO-X	RSTO	STO-X
RNAS5	RNAS5R	8.9	—	—	—	7	16	—	7.8	—	2 740	2 390	RSTO5TNX	RSTO5TN	—	
RNAS6	RNAS6R	13.9	NAS6	NAS6R	17.8	10	19	6	9.8	10	4 120	4 550	RSTO6TNX	RSTO6TN	STO6TNX	
RNAS8	RNAS8R	23.5	NAS8	NAS8R	28	12	24	8	9.8	10	5 680	5 890	RSTO8TNX	RSTO8TN	STO8TNX	
RNAS10	RNAS10R	42.5	NAS10	NAS10R	50	14	30	10	11.8	12	9 700	9 670	RSTO10X	RSTO10	STO10X	
RNAS12	RNAS12R	49.5	NAS12	NAS12R	58	16	32	12	11.8	12	10 400	10 900	RSTO12X	RSTO12	STO12X	
RNAS15	RNAS15R	50	NAS15	NAS15R	62	20	35	15	11.8	12	12 300	14 300	RSTO15X	RSTO15	STO15X	
RNAS17	RNAS17R	90	NAS17	NAS17R	110	22	40	17	15.8	16	17 400	20 900	RSTO17X	RSTO17	STO17X	
RNAS20	RNAS20R	135	NAS20	NAS20R	155	25	47	20	15.8	16	19 200	24 500	RSTO20X	RSTO20	STO20X	
RNAS25	RNAS25R	152	NAS25	NAS25R	180	30	52	25	15.8	16	20 700	28 400	RSTO25X	RSTO25	STO25X	
RNAS30	RNAS30R	255	NAS30	NAS30R	320	38	62	30	19.8	20	30 300	45 400	RSTO30X	RSTO30	STO30X	
RNAS35	RNAS35R	375	NAS35	NAS35R	440	42	72	35	19.8	20	32 200	50 600	RSTO35X	RSTO35	STO35X	
RNAS40	RNAS40R	420	NAS40	NAS40R	530	50	80	40	19.8	20	35 700	61 100	RSTO40X	RSTO40	STO40X	
RNAS45	RNAS45R	460	NAS45	NAS45R	580	55	85	45	19.8	20	37 100	66 400	RSTO45X	RSTO45	STO45X	
RNAS50	RNAS50R	500	NAS50	NAS50R	635	60	90	50	19.8	20	38 700	71 800	RSTO50X	RSTO50	STO50X	



INTERCHANGE

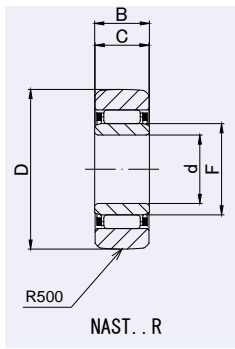

CROWNED OUTER RING WITH INNER RING	NTN				IKO				TORRINGTON(KOYO)			
	CYLINDRICAL OUTER RING WITHOUT INNER RING	CROWNED OUTER RING WITHOUT INNER RING	CYLINDRICAL OUTER RING WITH INNER RING	CROWNED OUTER RING WITH INNER RING	CYLINDRICAL OUTER RING WITHOUT INNER RING	CROWNED OUTER RING WITHOUT INNER RING	CYLINDRICAL OUTER RING WITH INNER RING	CROWNED OUTER RING WITH INNER RING	CYLINDRICAL OUTER RING WITHOUT INNER RING	CROWNED OUTER RING WITHOUT INNER RING	CYLINDRICAL OUTER RING WITH INNER RING	CROWNED OUTER RING WITH INNER RING
STO	RNAB-X	RNAB	NAB-X	NAB	RNAST	RNAST-R	NAST	NAST-R	RSTO-DZ	RSTO	STO-DZ	STO
—	RNAB2/5XT2	RNAB2/5T2	—	—	RNAST5	RNAST5R	—	—	RSTO5TN	RSTO5TN	—	—
STO6TN	RNAB2/6XT2	RNAB2/6T2	NAB2/6XT2	NAB2/6T2	RNAST6	RNAST6R	NAST6	NAST6R	RSTO6DZ	RSTO6	STO6DZ	STO6TN
STO8TN	RNAB2/8X	RNAB2/8	NAB2/8X	NAB2/8	RNAST8	RNAST8R	NAST8	NAST8R	RSTO8DZ	RSTO8	STO8DZ	STO8TN
STO10	RNAB200X	RNAB200	NAB200X	NAB200	RNAST10	RNAST10R	NAST10	NAST10R	RSTO10DZ	RSTO10	STO10DZ	STO10
STO12	RNAB201X	RNAB201	NAB201X	NAB201	RNAST12	RNAST12R	NAST12	NAST12R	RSTO12DZ	RSTO12	STO12DZ	STO12
STO15	RNAB202X	RNAB202	NAB202X	NAB202	RNAST15	RNAST15R	NAST15	NAST15R	RSTO15DZ	RSTO15	STO15DZ	STO15
STO17	RNAB203X	RNAB203	NAB203X	NAB203	RNAST17	RNAST17R	NAST17	NAST17R	RSTO17DZ	RSTO17	STO17DZ	STO17
STO20	RNAB204X	RNAB204	NAB204X	NAB204	RNAST20	RNAST20R	NAST20	NAST20R	RSTO20DZ	RSTO20	STO20DZ	STO20
STO25	RNAB205X	RNAB205	NAB205X	NAB205	RNAST25	RNAST25R	NAST25	NAST25R	RSTO25DZ	RSTO25	STO25DZ	STO25
STO30	RNAB206X	RNAB206	NAB206X	NAB206	RNAST30	RNAST30R	NAST30	NAST30R	RSTO30DZ	RSTO30	STO30DZ	STO30
STO35	RNAB207X	RNAB207	NAB207X	NAB207	RNAST35	RNAST35R	NAST35	NAST35R	RSTO35DZ	RSTO35	STO35DZ	STO35
STO40	RNAB208X	RNAB208	NAB208X	NAB208	RNAST40	RNAST40R	NAST40	NAST40R	RSTO40DZ	RSTO40	STO40DZ	STO40
STO45	RNAB209X	RNAB209	NAB209X	NAB209	RNAST45	RNAST45R	NAST45	NAST45R	RSTO45DZ	RSTO45	STO45DZ	STO45
STO50	RNAB210X	RNAB210	NAB210X	NAB210	RNAST50	RNAST50R	NAST50	NAST50R	RSTO50DZ	RSTO50	STO50DZ	STO50



INTERCHANGE

ROLLER FOLLOWERS

SEPARABLE WITH INNER RING WITH SHIELD

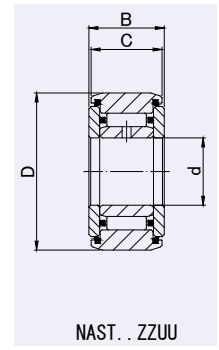
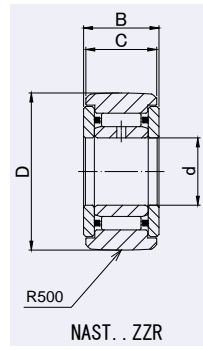
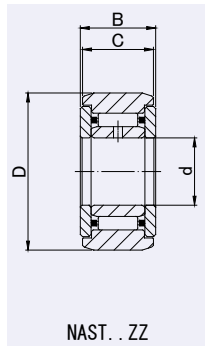

NAST..ZZ, ZZR, ZZUU, ZZUUR

DIMENSION TABLE

INTERCHANGE TABLE

JNS NUMBER CYLINDRICAL OUTER RING WITHOUT SEALS	JNS NUMBER CROWNED OUTER RING WITHOUT SEALS	JNS NUMBER CYLINDRICAL OUTER RING WITH SEALS	JNS NUMBER CROWNED OUTER RING WITH SEALS	Mass (Approx.) g	Dimensions(mm)				Basic dynamic load rating Cr N	Basic static load rating Cor N	INA	
					d	D	B	C			CYLINDRICAL OUTER RING	CROWNED OUTER RING
NAST..ZZ	NAST..ZZR	NAST..ZZUU	NAST..ZZUUR							—	—	
NAST6ZZ	NAST6ZZR	NAST6ZZUU	NAST6ZZUUR	24.5	6	19	14	13.8	4 120	4 550	—	—
NAST8ZZ	NAST8ZZR	NAST8ZZUU	NAST8ZZUUR	39	8	24	14	13.8	5 680	5 890	—	—
NAST10ZZ	NAST10ZZR	NAST10ZZUU	NAST10ZZUUR	65	10	30	16	15.8	9 700	9 670	—	—
NAST12ZZ	NAST12ZZR	NAST12ZZUU	NAST12ZZUUR	75	12	32	16	15.8	10 400	10 900	—	—
NAST15ZZ	NAST15ZZR	NAST15ZZUU	NAST15ZZUUR	83	15	35	16	15.8	12 300	14 300	—	—
NAST17ZZ	NAST17ZZR	NAST17ZZUU	NAST17ZZUUR	135	17	40	20	19.8	17 400	20 900	—	—
NAST20ZZ	NAST20ZZR	NAST20ZZUU	NAST20ZZUUR	195	20	47	20	19.8	19 200	24 500	—	—
NAST25ZZ	NAST25ZZR	NAST25ZZUU	NAST25ZZUUR	225	25	52	20	19.8	20 700	28 400	—	—
NAST30ZZ	NAST30ZZR	NAST30ZZUU	NAST30ZZUUR	400	30	62	25	24.8	30 300	45 400	—	—
NAST35ZZ	NAST35ZZR	NAST35ZZUU	NAST35ZZUUR	550	35	72	25	24.8	32 200	50 600	—	—
NAST40ZZ	NAST40ZZR	NAST40ZZUU	NAST40ZZUUR	710	40	80	26	25.8	35 700	61 100	—	—
NAST45ZZ	NAST45ZZR	NAST45ZZUU	NAST45ZZUUR	760	45	85	26	25.8	37 100	66 400	—	—
NAST50ZZ	NAST50ZZR	NAST50ZZUU	NAST50ZZUUR	830	50	90	26	25.8	38 700	71 800	—	—



INTERCHANGE

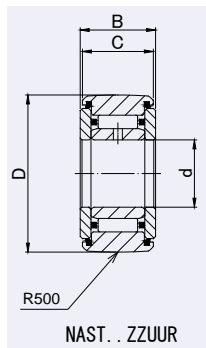

NTN		IKO				TORRINGTON(KOYO)			
CYLINDRICAL OUTER RING WITHOUT SEALS	CROWNED OUTER RING WITHOUT SEALS	CYLINDRICAL OUTER RING WITHOUT SEALS	CROWNED OUTER RING WITHOUT SEALS	CYLINDRICAL OUTER RING WITH SEALS	CROWNED OUTER RING WITH SEALS	CYLINDRICAL OUTER RING WITHOUT SEALS	CROWNED OUTER RING WITHOUT SEALS	CYLINDRICAL OUTER RING WITH SEALS	CROWNED OUTER RING WITH SEALS
—	—	NAST..ZZ	NAST..ZZR	NAST..ZZUU	NAST..ZZUUR	STO-ZZ.DZ	STO-ZZ	—	—
—	—	NAST6ZZ	NAST6ZZR	NAST6ZZUU	NAST6ZZUUR	STO6ZZ.DZ	STO6ZZ	—	—
—	—	NAST8ZZ	NAST8ZZR	NAST8ZZUU	NAST8ZZUUR	STO8ZZ.DZ	STO8ZZ	—	—
—	—	NAST10ZZ	NAST10ZZR	NAST10ZZUU	NAST10ZZUUR	STO10ZZ.DZ	STO10ZZ	—	—
—	—	NAST12ZZ	NAST12ZZR	NAST12ZZUU	NAST12ZZUUR	STO12ZZ.DZ	STO12ZZ	—	—
—	—	NAST15ZZ	NAST15ZZR	NAST15ZZUU	NAST15ZZUUR	STO15ZZ.DZ	STO15ZZ	—	—
—	—	NAST17ZZ	NAST17ZZR	NAST17ZZUU	NAST17ZZUUR	STO17ZZ.DZ	STO17ZZ	—	—
—	—	NAST20ZZ	NAST20ZZR	NAST20ZZUU	NAST20ZZUUR	STO20ZZ.DZ	STO20ZZ	—	—
—	—	NAST25ZZ	NAST25ZZR	NAST25ZZUU	NAST25ZZUUR	STO25ZZ.DZ	STO25ZZ	—	—
—	—	NAST30ZZ	NAST30ZZR	NAST30ZZUU	NAST30ZZUUR	STO30ZZ.DZ	STO30ZZ	—	—
—	—	NAST35ZZ	NAST35ZZR	NAST35ZZUU	NAST35ZZUUR	STO35ZZ.DZ	STO35ZZ	—	—
—	—	NAST40ZZ	NAST40ZZR	NAST40ZZUU	NAST40ZZUUR	STO40ZZ.DZ	STO40ZZ	—	—
—	—	NAST45ZZ	NAST45ZZR	NAST45ZZUU	NAST45ZZUUR	STO45ZZ.DZ	STO45ZZ	—	—
—	—	NAST50ZZ	NAST50ZZR	NAST50ZZUU	NAST50ZZUUR	STO50ZZ.DZ	STO50ZZ	—	—



INTERCHANGE

ROLLER FOLLOWERS

NON SEPARABLE WITH INNER RING

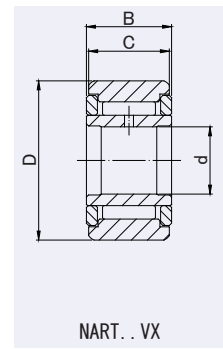
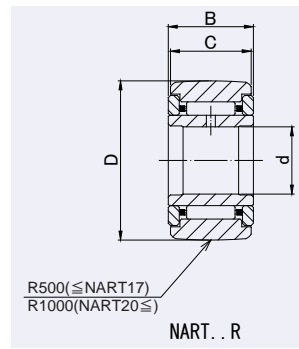
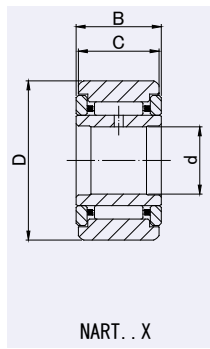

NART..X, R

DIMENSION TABLE

JNS NUMBER CYLINDRICAL OUTER RING	JNS NUMBER CROWNED OUTER RING	Mass (Approx.)	Dimensions(mm)				Basic dynamic load rating	Basic static load rating
			d	D	B	C		
NART..X	NART..R	g	d	D	B	C	Cr N	Cor N
NART5X	NART5R	14.5	5	16	12	11	3 620	3 720
NART5VX	NART5VR	15.1	5	16	12	11	6 760	8 340
NART6X	NART6R	20.5	6	19	12	11	4 200	4 700
NART6VX	NART6VR	21.5	6	19	12	11	7 640	10 300
NART8X	NART8R	41.5	8	24	15	14	6 600	7 300
NART8VX	NART8VR	42.5	8	24	15	14	11 800	15 600
NART10X	NART10R	64.5	10	30	15	14	8 600	8 300
NART10VX	NART10VR	66.5	10	30	15	14	15 600	18 100
NART12X	NART12R	71	12	32	15	14	9 100	9 200
NART12VX	NART12VR	73	12	32	15	14	16 800	20 500
NART15X	NART15R	102	15	35	19	18	14 400	17 600
NART15VX	NART15VR	106	15	35	19	18	25 100	36 400
NART17X	NART17R	149	17	40	21	20	18 600	22 500
NART17VX	NART17VR	155	17	40	21	20	32 000	46 200
NART20X	NART20R	250	20	47	25	24	24 100	32 700
NART20VX	NART20VR	255	20	47	25	24	41 700	67 300
NART25X	NART25R	285	25	52	25	24	25 800	37 500
NART25VX	NART25VR	295	25	52	25	24	45 500	79 000
NART30X	NART30R	470	30	62	29	28	36 200	56 900
NART30VX	NART30VR	485	30	62	29	28	59 800	110 400
NART35X	NART35R	640	35	72	29	28	38 200	62 800
NART35VX	NART35VR	655	35	72	29	28	63 000	121 500
NART40X	NART40R	845	40	80	32	30	46 200	84 700
NART40VX	NART40VR	865	40	80	32	30	76 200	164 200
NART45X	NART45R	915	45	85	32	30	49 300	95 200
NART45VX	NART45VR	935	45	85	32	30	80 200	181 100
NART50X	NART50R	980	50	90	32	30	51 100	102 300
NART50VX	NART50VR	1 010	50	90	32	30	84 100	198 000



INTERCHANGE

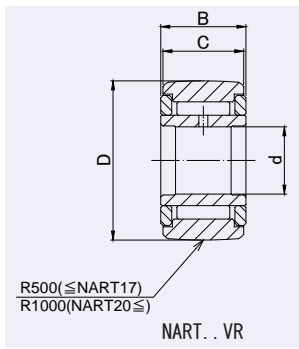

INTERCHANGE TABLE

INA		NTN		IKO		MCGILL	
CYLINDRICAL OUTER RING	CROWNED OUTER RING	CYLINDRICAL OUTER RING	CROWNED OUTER RING	CYLINDRICAL OUTER RING	CROWNED OUTER RING	CYLINDRICAL OUTER RING	CROWNED OUTER RING
NATR-X	NATR	NATR-X	NATR	—	NART-R	MCYRR-X	MCYRR
NATR5X	NATR5	NATR5X	NATR5	—	NART5R	MCYRR5X	MCYRR5
NATV5X	NATV5	NATV5X	NATV5	—	NART5VR	MCYR5X	MCYR5
NATR6X	NATR6	NATR6X	NATR6	—	NART6R	MCYRR6X	MCYRR6
NATV6X	NATV6	NATV6X	NATV6	—	NART6VR	MCYR6X	MCYR6
NATR8X	NATR8	NATR8X	NATR8	—	NART8R	MCYRR8X	MCYRR8
NATV8X	NATV8	NATV8X	NATV8	—	NART8VR	MCYR8X	MCYR8
NATR10X	NATR10	NATR10X	NATR10	—	NART10R	MCYRR10X	MCYRR10
NATV10X	NATV10	NATV10X	NATV10	—	NART10VR	MCYR10X	MCYR10
NATR12X	NATR12	NATR12X	NATR12	—	NART12R	MCYRR12X	MCYRR12
NATV12X	NATV12	NATV12X	NATV12	—	NART12VR	MCYR12X	MCYR12
NATR15X	NATR15	NATR15X	NATR15	—	NART15R	MCYRR15X	MCYRR15
NATV15X	NATV15	NATV15X	NATV15	—	NART15VR	MCYR15X	MCYR15
NATR17X	NATR17	NATR17X	NATR17	—	NART17R	MCYRR17X	MCYRR17
NATV17X	NATV17	NATV17X	NATV17	—	NART17VR	MCYR17X	MCYR17
NATR20X	NATR20	NATR20X	NATR20	—	NART20R	MCYRR20X	MCYRR20
NATV20X	NATV20	NATV20X	NATV20	—	NART20VR	MCYR20X	MCYR20
NATR25X	NATR25	NATR25X	NATR25	—	NART25R	MCYRR25X	MCYRR25
NATV25X	NATV25	NATV25X	NATV25	—	NART25VR	MCYR25X	MCYR25
NATR30X	NATR30	NATR30X	NATR30	—	NART30R	MCYRR30X	MCYRR30
NATV30X	NATV30	NATV30X	NATV30	—	NART30VR	MCYR30X	MCYR30
NATR35X	NATR35	NATR35X	NATR35	—	NART35R	MCYRR35X	MCYRR35
NATV35X	NATV35	NATV35X	NATV35	—	NART35VR	MCYR35X	MCYR35
NATR40X	NATR40	NATR40X	NATR40	—	NART40R	MCYRR40X	MCYRR40
NATV40X	NATV40	NATV40X	NATV40	—	NART40VR	MCYR40X	MCYR40
NATR45X	NATR45	NATR45X	NATR45	—	NART45R	MCYRR45X	MCYRR45
NATV45X	NATV45	NATV45X	NATV45	—	NART45VR	MCYR45X	MCYR45
NATR50X	NATR50	NATR50X	NATR50	—	NART50R	MCYRR50X	MCYRR50
NATV50X	NATV50	NATV50X	NATV50	—	NART50VR	MCYR50X	MCYR50



INTERCHANGE

ROLLER FOLLOWERS

NON SEPARABLE WITH INNER RING

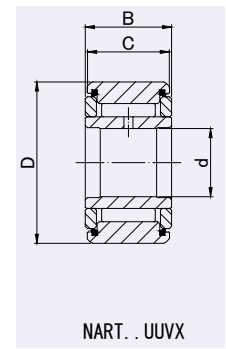
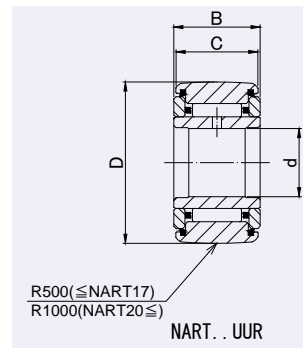
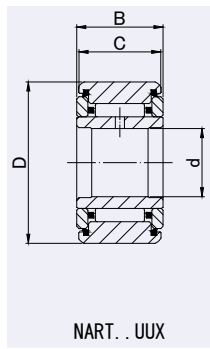

NART..UUX, UUR

DIMENSION TABLE

JNS NUMBER CYLINDRICAL OUTER RING	JNS NUMBER CROWNED OUTER RING	Mass (Approx.)	Dimensions(mm)				Basic dynamic load rating	Basic static load rating
			d	D	B	C		
NART..UUX	NART..UUR	g	d	D	B	C	Cr N	Cor N
NART5UUX	NART5UUR	14.5	5	16	12	11	3 620	3 720
NART5UUVX	NART5UUVR	15.1	5	16	12	11	6 760	8 340
NART6UUX	NART6UUR	20.5	6	19	12	11	4 200	4 700
NART6UUVX	NART6UUVR	21.5	6	19	12	11	7 640	10 300
NART8UUX	NART8UUR	41.5	8	24	15	14	6 600	7 300
NART8UUVX	NART8UUVR	42.5	8	24	15	14	11 800	15 600
NART10UUX	NART10UUR	64.5	10	30	15	14	8 600	8 300
NART10UUVX	NART10UUVR	66.5	10	30	15	14	15 600	18 100
NART12UUX	NART12UUR	71	12	32	15	14	9 100	9 200
NART12UUVX	NART12UUVR	73	12	32	15	14	16 800	20 500
NART15UUX	NART15UUR	102	15	35	19	18	14 400	17 600
NART15UUVX	NART15UUVR	106	15	35	19	18	25 100	36 400
NART17UUX	NART17UUR	149	17	40	21	20	18 600	22 500
NART17UUVX	NART17UUVR	155	17	40	21	20	32 000	46 200
NART20UUX	NART20UUR	250	20	47	25	24	24 100	32 700
NART20UUVX	NART20UUVR	255	20	47	25	24	41 700	67 300
NART25UUX	NART25UUR	285	25	52	25	24	25 800	37 500
NART25UUVX	NART25UUVR	295	25	52	25	24	45 500	79 000
NART30UUX	NART30UUR	470	30	62	29	28	36 200	56 900
NART30UUVX	NART30UUVR	485	30	62	29	28	59 800	110 400
NART35UUX	NART35UUR	640	35	72	29	28	38 200	62 800
NART35UUVX	NART35UUVR	655	35	72	29	28	63 000	121 500
NART40UUX	NART40UUR	845	40	80	32	30	46 200	84 700
NART40UUVX	NART40UUVR	865	40	80	32	30	76 200	164 200
NART45UUX	NART45UUR	915	45	85	32	30	49 300	95 200
NART45UUVX	NART45UUVR	935	45	85	32	30	80 200	181 100
NART50UUX	NART50UUR	980	50	90	32	30	51 100	102 300
NART50UUVX	NART50UUVR	1 010	50	90	32	30	84 100	198 000



INTERCHANGE

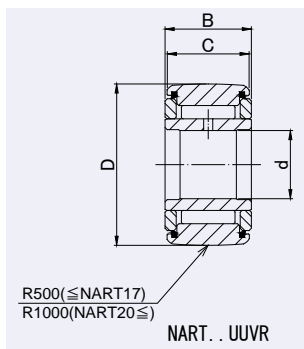

INTERCHANGE TABLE

INA		NTN		IKO		MCGILL	
CYLINDRICAL OUTER RING	CROWNED OUTER RING	CYLINDRICAL OUTER RING	CROWNED OUTER RING	CYLINDRICAL OUTER RING	CROWNED OUTER RING	CYLINDRICAL OUTER RING	CROWNED OUTER RING
NATR-PPX	NATR-PP	NATR-XLL	NATR-LL	—	NART-UUR	MCYRR-SX	MCYRR-S
NATR5PPX	NATR5PP	NATR5XLL	NATR5LL	—	NART5UUR	MCYRR5SX	MCYRR5S
NATV5PPX	NATV5PP	NATV5XLL	NATV5LL	—	NART5VUUR	MCYR5SX	MCYR5S
NATR6PPX	NATR6PP	NATR6XLL	NATR6LL	—	NART6UUR	MCYRR6SX	MCYRR6S
NATV6PPX	NATV6PP	NATV6XLL	NATV6LL	—	NART6VUUR	MCYR6SX	MCYR6S
NATR8PPX	NATR8PP	NATR8XLL	NATR8LL	—	NART8UUR	MCYRR8SX	MCYRR8S
NATV8PPX	NATV8PP	NATV8XLL	NATV8LL	—	NART8VUUR	MCYR8SX	MCYR8S
NATR10PPX	NATR10PP	NATR10XLL	NATR10LL	—	NART10UUR	MCYRR10SX	MCYRR10S
NATV10PPX	NATV10PP	NATV10XLL	NATV10LL	—	NART10VUUR	MCYR10SX	MCYR10S
NATR12PPX	NATR12PP	NATR12XLL	NATR12LL	—	NART12UUR	MCYRR12SX	MCYRR12S
NATV12PPX	NATV12PP	NATV12XLL	NATV12LL	—	NART12VUUR	MCYR12SX	MCYR12S
NATR15PPX	NATR15PP	NATR15XLL	NATR15LL	—	NART15UUR	MCYRR15SX	MCYRR15S
NATV15PPX	NATV15PP	NATV15XLL	NATV15LL	—	NART15VUUR	MCYR15SX	MCYR15S
NATR17PPX	NATR17PP	NATR17XLL	NATR17LL	—	NART17UUR	MCYRR17SX	MCYRR17S
NATV17PPX	NATV17PP	NATV17XLL	NATV17LL	—	NART17VUUR	MCYR17SX	MCYR17S
NATR20PPX	NATR20PP	NATR20XLL	NATR20LL	—	NART20UUR	MCYRR20SX	MCYRR20S
NATV20PPX	NATV20PP	NATV20XLL	NATV20LL	—	NART20VUUR	MCYR20SX	MCYR20S
NATR25PPX	NATR25PP	NATR25XLL	NATR25LL	—	NART25UUR	MCYRR25SX	MCYRR25S
NATV25PPX	NATV25PP	NATV25XLL	NATV25LL	—	NART25VUUR	MCYR25SX	MCYR25S
NATR30PPX	NATR30PP	NATR30XLL	NATR30LL	—	NART30UUR	MCYRR30SX	MCYRR30S
NATV30PPX	NATV30PP	NATV30XLL	NATV30LL	—	NART30VUUR	MCYR30SX	MCYR30S
NATR35PPX	NATR35PP	NATR35XLL	NATR35LL	—	NART35UUR	MCYRR35SX	MCYRR35S
NATV35PPX	NATV35PP	NATV35XLL	NATV35LL	—	NART35VUUR	MCYR35SX	MCYR35S
NATR40PPX	NATR40PP	NATR40XLL	NATR40LL	—	NART40UUR	MCYRR40SX	MCYRR40S
NATV40PPX	NATV40PP	NATV40XLL	NATV40LL	—	NART40VUUR	MCYR40SX	MCYR40S
NATR45PPX	NATR45PP	NATR45XLL	NATR45LL	—	NART45UUR	MCYRR45SX	MCYRR45S
NATV45PPX	NATV45PP	NATV45XLL	NATV45LL	—	NART45VUUR	MCYR45SX	MCYR45S
NATR50PPX	NATR50PP	NATR50XLL	NATR50LL	—	NART50UUR	MCYRR50SX	MCYRR50S
NATV50PPX	NATV50PP	NATV50XLL	NATV50LL	—	NART50VUUR	MCYR50SX	MCYR50S



INTERCHANGE

HEAVY DUTY TYPE ROLLER FOLLOWERS

NON SEPARABLE
WITH INNER RING

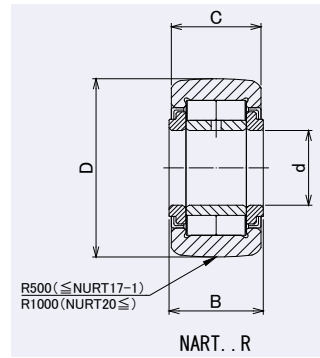
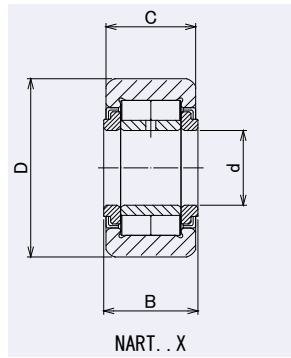

NURT..X, R

DIMENSION TABLE

JNS NUMBER CYLINDRICAL OUTER RING	JNS NUMBER CROWNED OUTER RING	Mass (Approx.)	Dimensions(mm)				Basic dynamic load rating	Basic static load rating
			d	D	B	C		
NURT..X	NURT..R	g	d	D	B	C	Cr N	Cor N
NURT15X	NURT15R	100	15	35	19	18	22 300	25 700
NURT15-1X	NURT15-1R	160	15	42	19	18	22 300	25 700
NURT17X	NURT17R	147	17	40	21	20	24 100	29 100
NURT17-1X	NURT17-1R	222	17	47	21	20	24 100	29 100
NURT20X	NURT20R	245	20	47	25	24	38 500	48 000
NURT20-1X	NURT20-1R	321	20	52	25	24	38 500	48 000
NURT25X	NURT25R	281	25	52	25	24	42 500	57 500
NURT25-1X	NURT25-1R	450	25	62	25	24	42 500	57 500
NURT30X	NURT30R	466	30	62	29	28	56 500	72 500
NURT30-1X	NURT30-1R	697	30	72	29	28	56 500	72 500
NURT35X	NURT35R	630	35	72	29	28	62 000	85 500
NURT35-1X	NURT35-1R	840	35	80	29	28	62 000	85 500
NURT40X	NURT40R	817	40	80	32	30	87 000	125 000
NURT40-1X	NURT40-1R	1 130	40	90	32	30	87 000	125 000
NURT45X	NURT45R	883	45	85	32	30	92 000	137 000
NURT45-1X	NURT45-1R	1 400	45	100	32	30	92 000	137 000
NURT50X	NURT50R	950	50	90	32	30	96 500	150 000
NURT50-1X	NURT50-1R	1 690	50	110	32	30	96 500	150 000



INTERCHANGE

INTERCHANGE TABLE

INA		NTN		IKO		MCGILL	
CYLINDRICAL OUTER RING	CROWNED OUTER RING	CYLINDRICAL OUTER RING	CROWNED OUTER RING	CYLINDRICAL OUTER RING	CROWNED OUTER RING	CYLINDRICAL OUTER RING	CROWNED OUTER RING
—	NUTR	NUTR-X	NUTR	NURT	NURT-R	MCYRD-X	MCYRD
—	NUTR15	NUTR202X	NUTR202	NURT15	NURT15R	MCYRD-15X	MCYRD-15
—	NUTR15 42	NUTR302X	NUTR302	NURT15-1	NURT15-1R	—	—
—	NUTR17	NUTR203X	NUTR203	NURT17	NURT17R	MCYRD-17X	MCYRD-17
—	NUTR17 47	NUTR303X	NUTR303	NURT17-1	NURT17-1R	—	—
—	NUTR20	NUTR204X	NUTR204	NURT20	NURT20R	MCYRD-20X	MCYRD-20
—	NUTR20 52	NUTR304X	NUTR304	NURT20-1	NURT20-1R	—	—
—	NUTR25	NUTR205X	NUTR205	NURT25	NURT25R	MCYRD-25X	MCYRD-25
—	NUTR25 62	NUTR305X	NUTR305	NURT25-1	NURT25-1R	—	—
—	NUTR30	NUTR206X	NUTR206	NURT30	NURT30R	MCYRD-30X	MCYRD-30
—	NUTR30 72	NUTR306X	NUTR306	NURT30-1	NURT30-1R	—	—
—	NUTR35	NUTR207X	NUTR207	NURT35	NURT35R	MCYRD-35X	MCYRD-35
—	NUTR35 80	NUTR307X	NUTR307	NURT35-1	NURT35-1R	—	—
—	NUTR40	NUTR208X	NUTR208	NURT40	NURT40R	MCYRD-40X	MCYRD-40
—	NUTR40 90	NUTR308X	NUTR308	NURT40-1	NURT40-1R	—	—
—	NUTR45	NUTR209X	NUTR209	NURT45	NURT45R	MCYRD-45X	MCYRD-45
—	NUTR45 100	NUTR309X	NUTR309	NURT45-1	NURT45-1R	—	—
—	NUTR50	NUTR210X	NUTR210	NURT50	NURT50R	MCYRD-50X	MCYRD-50
—	NUTR50 110	NUTR310X	NUTR310	NURT50-1	NURT50-1R	—	—



INTERCHANGE

INTERCHANGE TABLE

STAINLESS STEEL



**MACHINED RING NEEDLE
ROLLER BEARINGS
STAINLESS STEEL
WITH INNER RING
WITHOUT INNER RING**

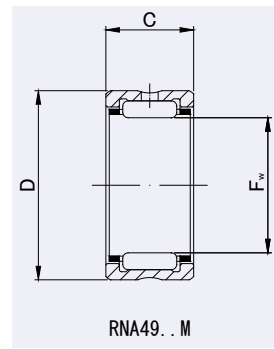
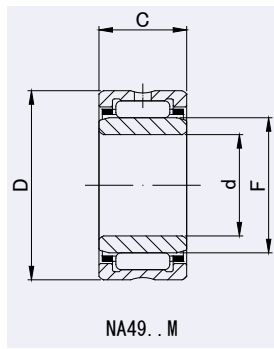

NA49M, RNA49M

DIMENSION TABLE

JNS NUMBER WITH INNER RING	Mass (Approx.)	JNS NUMBER WITHOUT INNER RING	Mass (Approx.)	JNS NUMBER Assembled INNER RING	Dimensions(mm)				Basic dynamic load rating	Basic static load rating
					d	Fw (F)	D	C		
NA 49M	g	RNA 49M	g	IR..M					Cr N	Cor N
NA495M	7.3	RNA495M	5.9	IR5710M	5	7	13	10	2 700	2 400
NA496M	9.1	RNA496M	7.3	IR6810M	6	8	15	10	3 500	3 100
NA497M	11.2	RNA497M	9.3	IR7910M	7	9	17	10	4 100	3 300
NA498M	15	RNA498M	12.6	IR81011M	8	10	19	11	5 700	4 600
NA499M	16.7	RNA499M	13.6	IR91211M	9	12	20	11	6 000	5 700
NA4900M	24	RNA4900M	16.5	IR101413M	10	14	22	13	8 400	9 200
NA4901M	26.5	RNA4901M	18.1	IR121613M	12	16	24	13	8 900	10 200
NA4902M	35	RNA4902M	21.5	IR152013M	15	20	28	13	10 000	12 600
NA4903M	39	RNA4903M	23.5	IR172213M	17	22	30	13	10 800	14 300
NA4904M	78.5	RNA4904M	55.5	IR202517M	20	25	37	17	19 300	23 000
NA49/22M	87	RNA49/22M	56.5	IR222817M	22	28	39	17	19 600	26 400
NA4905M	92.5	RNA4905M	64	IR253017M	25	30	42	17	21 800	28 200



INTERCHANGE

MACHINED RING NEEDLE ROLLER BEARINGS STAINLESS STEEL WITH INNER RING WITHOUT INNER RING

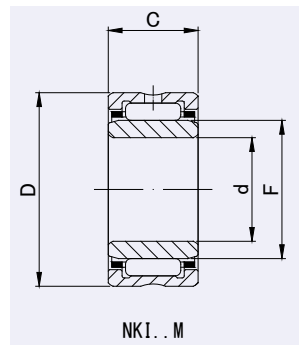
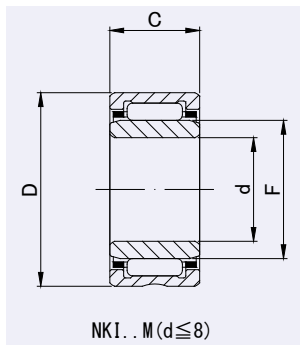

NK1..M, NK..M

DIMENSION TABLE

JNS NUMBER WITH INNER RING	Mass (Approx.)	JNS NUMBER WITHOUT INNER RING	Mass (Approx.)	JNS NUMBER Assembled INNER RING	Dimensions(mm)				Basic dynamic load rating	Basic static load rating
					d	Fw (F)	D	C		
NK1..M	g	NK..M	g	IR..M	d	Fw (F)	D	C	Cr N	Cor N
—	—	NK5/10M	3.4	—	—	5	10	10	2 200	1 700
—	—	NK5/12M	4.2	—	—	5	10	12	2 800	2 400
—	—	NK6/10M	5.3	—	—	6	12	10	2 400	2 100
—	—	NK6/12M	6.4	—	—	6	12	12	3 100	2 900
—	—	NK7/10M	6.9	—	—	7	14	10	3 300	2 700
—	—	NK7/12M	8.3	—	—	7	14	12	4 200	3 700
NKI 5/12M	11.9	NK8/12M	9	IR5812M	5	8	15	12	4 600	4 300
NKI 5/16M	16.7	NK8/16M	13	IR5816M	5	8	15	16	6 500	6 700
NKI 6/12M	13	NK9/12M	10	IR6912M	6	9	16	12	5 000	4 800
NKI 6/16M	17.5	NK9/16M	13.2	IR6916M	6	9	16	16	6 900	7 500
NKI 7/12M	14.3	NK10/12M	10.7	IR71012M	7	10	17	12	5 400	5 500
NKI 7/16M	19.2	NK10/16M	14.3	IR71016M	7	10	17	16	7 500	8 400
NKI 9/12M	16.7	NK12/12M	12.2	IR91212M	9	12	19	12	6 000	6 700
NKI 9/16M	22.5	NK12/16M	16.3	IR91216M	9	12	19	16	8 400	10 300
NKI 10/16M	30	NK14/16M	21	IR101416M	10	14	22	16	10 800	12 600
NKI 10/20M	38	NK14/20M	26.5	IR101420M	10	14	22	20	13 600	17 000
—	—	NK15/16M	22.5	—	—	15	23	16	11 400	13 700
—	—	NK15/20M	28	—	—	15	23	20	14 300	18 500
NKI 12/16M	33.5	NK16/16M	23	IR121616M	12	16	24	16	11 300	13 800
NKI 12/20M	42.5	NK16/20M	29	IR121620M	12	16	24	20	14 300	18 700
—	—	NK17/16M	24.5	—	—	17	25	16	11 700	14 900
—	—	NK17/20M	30.5	—	—	17	25	20	14 900	20 300
—	—	NK18/16M	25.5	—	—	18	26	16	12 300	16 100
—	—	NK18/20M	32	—	—	18	26	20	15 600	21 700
NKI 15/16M	39.5	NK19/16M	27	IR151916M	15	19	27	16	12 800	17 200
NKI 15/20M	50	NK19/20M	34	IR151920M	15	19	27	20	16 200	23 200

NK type of 10mm or less inscribed circle diameter (Fw) is without oil hole.

NKI type of 8mm or less inscribed circle diameter (d) is without oil hole.



INTERCHANGE

INNER RINGS STAINLESS STEEL

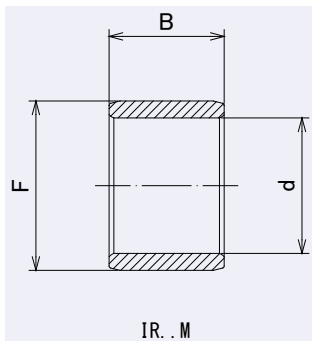

IR..M

DIMENSION TABLE

INTERCHANGE TABLE

JNS NUMBER WITH INNER RING	Mass (Approx.) g	Dimensions(mm)			JNS USABLE BEARING NUMBER	IKO
		d	F	B		
IR						—
IR5710M	1.4	5	7	10	RNA495M	—
IR5812M	3	5	8	12	NK8/12M	—
IR5816M	4	5	8	16	NK8/16M	—
IR6810M	1.7	6	8	10	RNA496M	—
IR6912M	3.2	6	9	12	NK9/12M	—
IR6916M	4.3	6	9	16	NK9/16M	—
IR61010M	4	6	10	10	—	—
IR7910M	1.9	7	9	10	RNA497M	—
IR71012M	3.6	7	10	12	NK10/12M	—
IR71016M	5	7	10	16	NK10/16M	—
IR81011M	2.4	8	10	11	RNA498M	—
IR81210M	4.8	8	12	10	—	—
IR91211M	3.1	9	12	11	RNA499M	—
IR91212M	4.5	9	12	12	NK12/12M	—
IR91216M	6	9	12	16	NK12/16M	—
IR101412M	7	10	14	12	—	—
IR101413M	7.5	10	14	13	RNA4900M	—
IR101416M	9	10	14	16	NK14/16M	—
IR101420M	11.5	10	14	20	NK14/20M	—
IR121612M	8	12	16	12	—	—
IR121613M	8.5	12	16	13	RNA4901M	—
IR121616M	10.5	12	16	16	NK16/16M	—
IR121620M	13.5	12	16	20	NK16/20M	—
IR151916M	12.5	15	19	16	NK19/16M	—
IR151920M	16	15	19	20	NK19/20M	—
IR152012M	12	15	20	12	—	—
IR152013M	13.5	15	20	13	RNA4902M	—
IR172213M	15.5	17	22	13	RNA4903M	—
IR172216M	19	17	22	16	—	—
IR202516M	22	20	25	16	—	—
IR202517M	23	20	25	17	RNA4904M	—
IR253016M	28	25	30	16	—	—
IR253017M	28.5	25	30	17	RNA4905M	—
IR 303820M	65	30	38	20	—	—
IR 354220M	65	35	42	20	—	—
IR 506020M	135	50	60	20	—	—



INTERCHANGE

**CAM FOLLOWERS
STAINLESS STEEL**
MINIATURE TYPE
HEXAGON SOCKET ON STUD HEAD

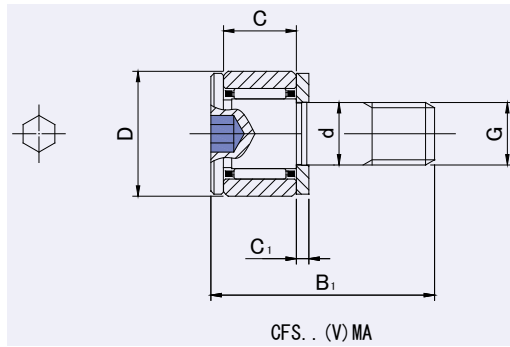

CFS..MA

DIMENSION TABLE

JNS NUMBER CYLINDRICAL OUTER RING	Mass (Approx.)	Dimensions(mm)						Basic dynamic load rating	Basic static load rating	
		CFS	g	d	D	C	G			
CFS 2.5MA	1	2.5	5	3	M2.5×0.45	9.5	0.7	370	300	
CFS 2.5VMA	1	2.5	5	3	M2.5×0.45	9.5	0.7	920	990	
CFS 3MA	2	3	6	4	M3×0.5	11.5	0.7	570	560	
CFS 3VMA	2	3	6	4	M3×0.5	11.5	0.7	1 260	1 620	
CFS 4MA	4	4	8	5	M4×0.7	15	1	990	990	
CFS 4VMA	4	4	8	5	M4×0.7	15	1	2 160	2 790	
CFS 5MA	7	5	10	6	M5×0.8	18	1	1 440	1 710	
CFS 5VMA	7	5	10	6	M5×0.8	18	1	2 880	4 330	
CFS 6MA	13	6	12	7	M6×1	21.5	1.2	1 890	1 980	
CFS 6VMA	13	6	12	7	M6×1	21.5	1.2	4 240	5 760	



INTERCHANGE

INTERCHANGE TABLE

INA	IKO	NTN	MCGILL
CYLINDRICAL OUTER RING	CYLINDRICAL OUTER RING	CYLINDRICAL OUTER RING	CYLINDRICAL OUTER RING
—	CFS-F	2F-KRM	—
—	CFS2.5F	2F-KRM5XT2H/3A	—
—	CFS2.5FV	2F-KRMV5XT2H/3A	—
—	CFS3F	2F-KRM6XT2H/3A	—
—	CFS3FV	2F-KRMV6XT2H/3A	—
—	CFS4F	2F-KRM8XT2H/3A	—
—	CFS4FV	2F-KRMV8XT2H/3A	—
—	CFS5F	2F-KRM10XT2H/3A	—
—	CFS5FV	2F-KRMV10XT2H/3A	—
—	CFS6F	2F-KRM12XT2H/3A	—
—	CFS6FV	2F-KRMV12XT2H/3A	—



CAM FOLLOWERS STAINLESS STEEL HEXAGON SOCKET ON STUD HEAD

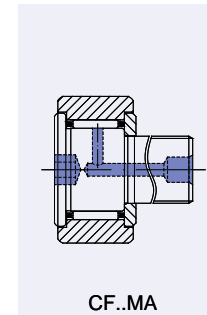
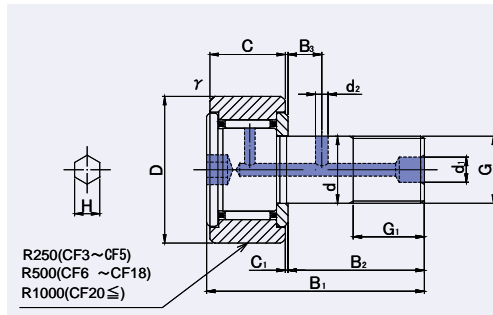

CF..MA, MRA, MUUA, MUURA

DIMENSION TABLE

JNS NUMBER CYLINDRICAL OUTER RING WITHOUT SEALS	JNS NUMBER CROWNED OUTER RING WITHOUT SEALS	JNS NUMBER CYLINDRICAL OUTER RING WITH SEALS	JNS NUMBER CROWNED OUTER RING WITH SEALS	Mass (Approx.)	Dimensions(mm)						Basic dynamic load rating	Basic static load rating
CF..MA	CF..MRA	CF..MUUA	CF..MUURA	g	d	D	C	G	B1	C1	Cr N	Cor N
CF3MA	CF3MRA	CF3MUUA	CF3MUURA	4.5	3	10	7	M3×0.5	17	0.5	1 350	1 080
CF3VMA	CF3VMRA	CF3VMUUA	CF3VMUURA	4.5	3	10	7	M3×0.5	17	0.5	2 570	2 300
CF4MA	CF4MRA	CF4MUUA	CF4MUURA	7.5	4	12	8	M4×0.7	20	0.5	1 890	1 880
CF4VMA	CF4VMRA	CF4VMUUA	CF4VMUURA	7.5	4	12	8	M4×0.7	20	0.5	3 680	3 950
CF5MA	CF5MRA	CF5MUUA	CF5MUURA	10.5	5	13	9	M5×0.8	23	0.5	2 880	2 540
CF5VMA	CF5VMRA	CF5VMUUA	CF5VMUURA	10.5	5	13	9	M5×0.8	23	0.5	4 690	5 060
CF6MA	CF6MRA	CF6MUUA	CF6MUURA	18.5	6	16	11	M6×1	28	0.6	3 330	3 330
CF6VMA	CF6VMRA	CF6VMUUA	CF6VMUURA	18.5	6	16	11	M6×1	28	0.6	6 400	7 840
CF8MA	CF8MRA	CF8MUUA	CF8MUURA	28.5	8	19	11	M8×1.25	32	0.6	3 960	4 330
CF8VMA	CF8VMRA	CF8VMUUA	CF8VMUURA	28.5	8	19	11	M8×1.25	32	0.6	7 470	10 270
CF10MA	CF10MRA	CF10MUUA	CF10MUURA	45	10	22	12	M10×1.25	36	0.6	4 950	6 310
CF10VMA	CF10VMRA	CF10VMUUA	CF10VMUURA	45	10	22	12	M10×1.25	36	0.6	8 740	13 340
CF10MAK	CF10MRAK	CF10MUUAK	CF10MUURAK	45	10	22	12	M10×1	36	0.6	4 950	6 310
CF10VMAK	CF10VMRAK	CF10VMUUAK	CF10VMUURAK	45	10	22	12	M10×1	36	0.6	8 740	13 340
CF10-1MA	CF10-1MRA	CF10-1MUUA	CF10-1MUURA	60	10	26	12	M10×1.25	36	0.6	4 950	6 310
CF10-1VMA	CF10-1VMRA	CF10-1VMUUA	CF10-1VMUURA	60	10	26	12	M10×1.25	36	0.6	8 740	13 340
CF10-1MAK	CF10-1MRAK	CF10-1MUUAK	CF10-1MUURAK	60	10	26	12	M10×1	36	0.6	4 950	6 310
CF10-1VMAK	CF10-1VMRAK	CF10-1VMUUAK	CF10-1VMUURAK	60	10	26	12	M10×1	36	0.6	8 740	13 340
CF12MA	CF12MRA	CF12MUUA	CF12MUURA	95	12	30	14	M12×1.5	40	0.6	7 300	9 010
CF12VMA	CF12VMRA	CF12VMUUA	CF12VMUURA	95	12	30	14	M12×1.5	40	0.6	12 350	18 120
CF12-1MA	CF12-1MRA	CF12-1MUUA	CF12-1MUURA	105	12	32	14	M12×1.5	40	0.6	7 300	9 010
CF12-1VMA	CF12-1VMRA	CF12-1VMUUA	CF12-1VMUURA	105	12	32	14	M12×1.5	40	0.6	12 350	18 120
CF16MA	CF16MRA	CF16MUUA	CF16MUURA	170	16	35	18	M16×1.5	52	0.8	11 080	16 860
CF16VMA	CF16VMRA	CF16VMUUA	CF16VMUURA	170	16	35	18	M16×1.5	52	0.8	19 020	34 610
CF18MA	CF18MRA	CF18MUUA	CF18MUURA	250	18	40	20	M18×1.5	58	0.8	13 520	23 180
CF18VMA	CF18VMRA	CF18VMUUA	CF18VMUURA	250	18	40	20	M18×1.5	58	0.8	23 250	47 240
CF20MA	CF20MRA	CF20MUUA	CF20MUURA	460	20	52	24	M20×1.5	66	0.8	19 020	31 830
CF20VMA	CF20VMRA	CF20VMUUA	CF20VMUURA	460	20	52	24	M20×1.5	66	0.8	30 470	59 320
CF20-1MA	CF20-1MRA	CF20-1MUUA	CF20-1MUURA	385	20	47	24	M20×1.5	66	0.8	19 020	31 830
CF20-1VMA	CF20-1VMRA	CF20-1VMUUA	CF20-1VMUURA	385	20	47	24	M20×1.5	66	0.8	30 470	59 320
CF24MA	CF24MRA	CF24MUUA	CF24MUURA	815	24	62	29	M24×1.5	80	0.8	28 040	48 410
CF24VMA	CF24VMRA	CF24VMUUA	CF24VMUURA	815	24	62	29	M24×1.5	80	0.8	42 820	84 650
CF24-1MA	CF24-1MRA	CF24-1MUUA	CF24-1MUURA	1 140	24	72	29	M24×1.5	80	0.8	28 040	48 410
CF24-1VMA	CF24-1VMRA	CF24-1VMUUA	CF24-1VMUURA	1 140	24	72	29	M24×1.5	80	0.8	42 820	84 650

Stud diameter (d) 3 to 10mm : No grease refilling hole is provided (except "K" type)



INTERCHANGE

CAM FOLLOWERS STAINLESS STEEL HEXAGON SOCKET ON STUD HEAD

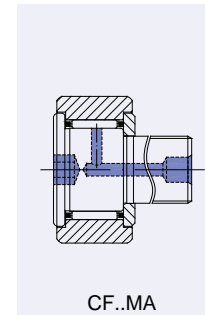
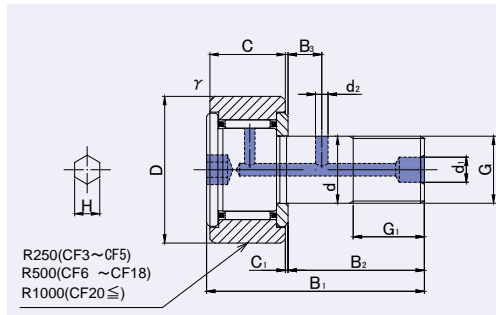

CF..MA, MRA, MUUA, MUURA

DIMENSION TABLE

JNS NUMBER CYLINDRICAL OUTER RING WITHOUT SEALS	JNS NUMBER CROWNED OUTER RING WITHOUT SEALS	JNS NUMBER CYLINDRICAL OUTER RING WITH SEALS	JNS NUMBER CROWNED OUTER RING WITH SEALS	Mass (Approx.) g	Dimensions(mm)						Basic dynamic load rating Cr N	Basic static load rating Cor N
					d	D	C	G	B1	C1		
CF..MA	CF..MRA	CF..MUUA	CF..MUURA		d	D	C	G	B1	C1	Cr N	Cor N
CF30MA	CF30MRA	CF30MUUA	CF30MUURA	1 870	30	80	35	M30×1.5	100	1	41 740	78 250
CF30VMA	CF30VMRA	CF30VMUUA	CF30VMUURA	1 870	30	80	35	M30×1.5	100	1	62 210	132 530
CF30-1MA	CF30-1MRA	CF30-1MUUA	CF30-1MUURA	2 030	30	85	35	M30×1.5	100	1	41 740	78 250
CF30-1VMA	CF30-1VMRA	CF30-1VMUUA	CF30-1VMUURA	2 030	30	85	35	M30×1.5	100	1	62 210	132 530
CF30-2MA	CF30-2MRA	CF30-2MUUA	CF30-2MUURA	2 220	30	90	35	M30×1.5	100	1	41 740	78 250
CF30-2VMA	CF30-2VMRA	CF30-2VMUUA	CF30-2VMUURA	2 220	30	90	35	M30×1.5	100	1	62 210	132 530

Stud diameter (d) 3 to 10mm : No grease refilling hole is provided (except "K" type)



INTERCHANGE

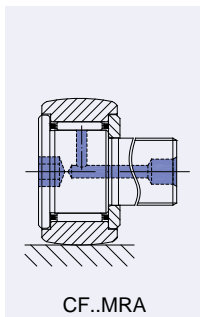

CF..MRA

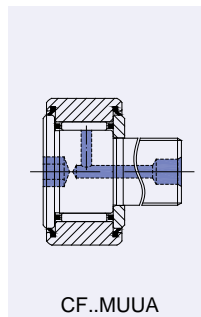

CF..MUUA

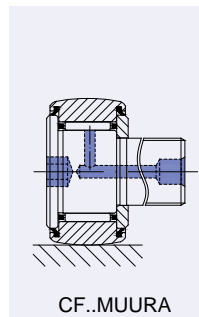

CF..MUURA

INTERCHANGE TABLE

INA		NTN		IKO				MCGILL	
CYLINDRICAL OUTER RING WITHOUT SEALS	CROWNED OUTER RING WITHOUT SEALS	CYLINDRICAL OUTER RING WITHOUT SEALS	CROWNED OUTER RING WITHOUT SEALS	CYLINDRICAL OUTER RING WITHOUT SEALS	CROWNED OUTER RING WITHOUT SEALS	CYLINDRICAL OUTER RING WITH SEALS	CROWNED OUTER RING WITH SEALS	CYLINDRICAL OUTER RING WITHOUT SEALS	CROWNED OUTER RING WITHOUT SEALS
—	—	—	—	—	—	—	—	—	—
—	—	—	—	—	—	—	—	—	—
—	—	—	—	—	—	—	—	—	—
—	—	—	—	—	—	—	—	—	—
—	—	—	—	—	—	—	—	—	—
—	—	—	—	—	—	—	—	—	—
—	—	—	—	—	—	—	—	—	—



CAM FOLLOWERS STAINLESS STEEL

HEXAGON SOCKET ON BOTH SIDES
GREASE NIPPLE INSTALLED

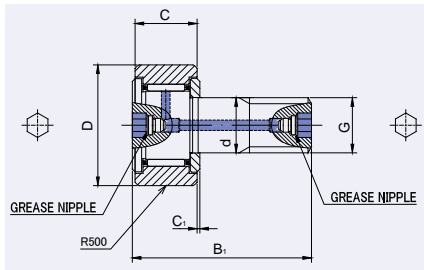

CF.. MAB (CF10MABK, CF10-1MABK)

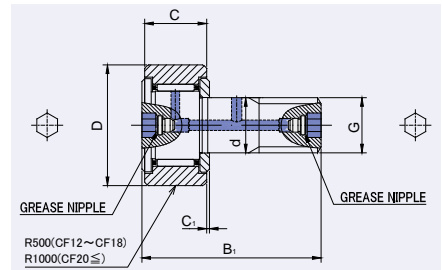

CF.. MAB (CF12 \leq)

CF..MAB, MRAB, MUUAB, MUURAB

DIMENSION TABLE

JNS NUMBER CYLINDRICAL OUTER RING WITHOUT SEALS	JNS NUMBER CROWNED OUTER RING WITHOUT SEALS	JNS NUMBER CYLINDRICAL OUTER RING WITH SEALS	JNS NUMBER CROWNED OUTER RING WITH SEALS	Mass (Approx.) g	Dimensions(mm)						Basic dynamic load rating Cr N	Basic static load rating Cor N
					d	D	C	G	B1	C1		
CF10MABK	CF10MRABK	CF10MUUABK	CF10MUURABK	45	10	22	12	M10×1	36	0.6	4 950	6 310
CF10VMABK	CF10VMRABK	CF10VMUUABK	CF10VMUURABK	45	10	22	12	M10×1	36	0.6	8 740	13 340
CF10-1MABK	CF10-1MRABK	CF10-1MUUABK	CF10-1MUURABK	60	10	26	12	M10×1	36	0.6	4 950	6 310
CF10-1VMABK	CF10-1VMRABK	CF10-1VMUUABK	CF10-1VMUURABK	60	10	26	12	M10×1	36	0.6	8 740	13 340
CF12MAB	CF12MRAB	CF12MUUAB	CF12MUURAB	95	12	30	14	M12×1.5	40	0.6	7 300	9 010
CF12VMAB	CF12VMRAB	CF12VMUUAB	CF12VMUURAB	95	12	30	14	M12×1.5	40	0.6	12 350	18 120
CF12-1MAB	CF12-1MRAB	CF12-1MUUAB	CF12-1MUURAB	105	12	32	14	M12×1.5	40	0.6	7 300	9 010
CF12-1VMAB	CF12-1VMRAB	CF12-1VMUUAB	CF12-1VMUURAB	105	12	32	14	M12×1.5	40	0.6	12 350	18 120
CF16MAB	CF16MRAB	CF16MUUAB	CF16MUURAB	170	16	35	18	M16×1.5	52	0.8	11 080	16 860
CF16VMAB	CF16VMRAB	CF16VMUUAB	CF16VMUURAB	170	16	35	18	M16×1.5	52	0.8	19 020	34 610
CF18MAB	CF18MRAB	CF18MUUAB	CF18MUURAB	250	18	40	20	M18×1.5	58	0.8	13 520	23 180
CF18VMAB	CF18VMRAB	CF18VMUUAB	CF18VMUURAB	250	18	40	20	M18×1.5	58	0.8	23 250	47 240
CF20MAB	CF20MRAB	CF20MUUAB	CF20MUURAB	460	20	52	24	M20×1.5	66	0.8	19 020	31 830
CF20VMAB	CF20VMRAB	CF20VMUUAB	CF20VMUURAB	460	20	52	24	M20×1.5	66	0.8	30 470	59 320
CF20-1MAB	CF20-1MRAB	CF20-1MUUAB	CF20-1MUURAB	385	20	47	24	M20×1.5	66	0.8	19 020	31 830
CF20-1VMAB	CF20-1VMRAB	CF20-1VMUUAB	CF20-1VMUURAB	385	20	47	24	M20×1.5	66	0.8	30 470	59 320
CF24MAB	CF24MRAB	CF24MUUAB	CF24MUURAB	815	24	62	29	M24×1.5	80	0.8	28 040	48 410
CF24VMAB	CF24VMRAB	CF24VMUUAB	CF24VMUURAB	815	24	62	29	M24×1.5	80	0.8	42 820	84 650
CF24-1MAB	CF24-1MRAB	CF24-1MUUAB	CF24-1MUURAB	1 140	24	72	29	M24×1.5	80	0.8	28 040	48 410
CF24-1VMAB	CF24-1VMRAB	CF24-1VMUUAB	CF24-1VMUURAB	1 140	24	72	29	M24×1.5	80	0.8	42 820	84 650
CF30MAB	CF30MRAB	CF30MUUAB	CF30MUURAB	1 870	30	80	35	M30×1.5	100	1	41 740	78 250
CF30VMAB	CF30VMRAB	CF30VMUUAB	CF30VMUURAB	1 870	30	80	35	M30×1.5	100	1	62 210	132 530
CF30-1MAB	CF30-1MRAB	CF30-1MUUAB	CF30-1MUURAB	2 030	30	85	35	M30×1.5	100	1	41 740	78 250
CF30-1VMAB	CF30-1VMRAB	CF30-1VMUUAB	CF30-1VMUURAB	2 030	30	85	35	M30×1.5	100	1	62 210	132 530
CF30-2MAB	CF30-2MRAB	CF30-2MUUAB	CF30-2MUURAB	2 220	30	90	35	M30×1.5	100	1	41 740	78 250
CF30-2VMAB	CF30-2VMRAB	CF30-2VMUUAB	CF30-2VMUURAB	2 220	30	90	35	M30×1.5	100	1	62 210	132 530



INTERCHANGE

CAM FOLLOWERS STAINLESS STEEL SCREWDRIVER SLOT HEAD

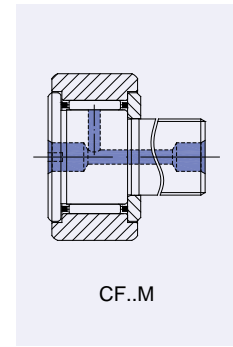
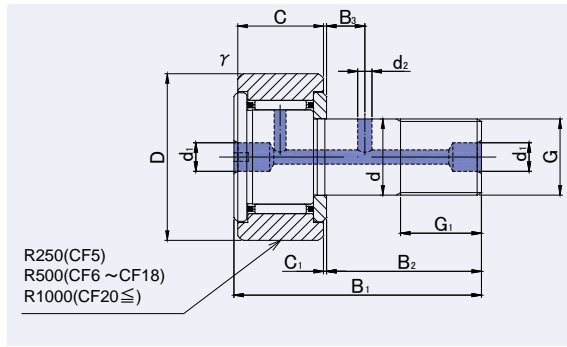

CF..M, MR, MUU, MUUR

DIMENSION TABLE

JNS NUMBER CYLINDRICAL OUTER RING WITHOUT SEALS	JNS NUMBER CROWNED OUTER RING WITHOUT SEALS	JNS NUMBER CYLINDRICAL OUTER RING WITH SEALS	JNS NUMBER CROWNED OUTER RING WITH SEALS	Mass (Approx.)	Dimensions(mm)						Basic dynamic load rating	Basic static load rating
CF..M	CF..MR	CF..MUU	CF..MUUR	g	d	D	C	G	B1	C1	Cr N	Cor N
CF5M	CF5MR	CF5MUU	CF5MUUR	10.5	5	13	9	M5×0.8	23	0.5	2 880	2 540
CF5VM	CF5VMR	CF5VMUU	CF5VMUUR	10.5	5	13	9	M5×0.8	23	0.5	4 690	5 060
CF6M	CF6MR	CF6MUU	CF6MUUR	18.5	6	16	11	M6×1	28	0.6	3 330	3 330
CF6VM	CF6VMR	CF6VMUU	CF6VMUUR	18.5	6	16	11	M6×1	28	0.6	6 400	7 840
CF8M	CF8MR	CF8MUU	CF8MUUR	28.5	8	19	11	M8×1.25	32	0.6	3 960	4 330
CF8VM	CF8VMR	CF8VMUU	CF8VMUUR	28.5	8	19	11	M8×1.25	32	0.6	7 470	10 270
CF10M	CF10MR	CF10MUU	CF10MUUR	45	10	22	12	M10×1.25	36	0.6	4 950	6 310
CF10VM	CF10VMR	CF10VMUU	CF10VMUUR	45	10	22	12	M10×1.25	36	0.6	8 740	13 340
CF10MK	CF10MRK	CF10MUUK	CF10MUURK	45	10	22	12	M10×1	36	0.6	4 950	6 310
CF10VMK	CF10VMRK	CF10VMUUK	CF10VMUURK	45	10	22	12	M10×1	36	0.6	8 740	13 340
CF10-1M	CF10-1MR	CF10-1MUU	CF10-1MUUR	60	10	26	12	M10×1.25	36	0.6	4 950	6 310
CF10-1VM	CF10-1VMR	CF10-1VMUU	CF10-1VMUUR	60	10	26	12	M10×1.25	36	0.6	8 740	13 340
CF10-1MK	CF10-1MRK	CF10-1MUUK	CF10-1MUURK	60	10	26	12	M10×1	36	0.6	4 950	6 310
CF10-1VMK	CF10-1VMRK	CF10-1VMUUK	CF10-1VMUURK	60	10	26	12	M10×1	36	0.6	8 740	13 340
CF12M	CF12MR	CF12MUU	CF12MUUR	95	12	30	14	M12×1.5	40	0.6	7 300	9 010
CF12VM	CF12VMR	CF12VMUU	CF12VMUUR	95	12	30	14	M12×1.5	40	0.6	12 350	18 120
CF12-1M	CF12-1MR	CF12-1MUU	CF12-1MUUR	105	12	32	14	M12×1.5	40	0.6	7 300	9 010
CF12-1VM	CF12-1VMR	CF12-1VMUU	CF12-1VMUUR	105	12	32	14	M12×1.5	40	0.6	12 350	18 120
CF16M	CF16MR	CF16MUU	CF16MUUR	170	16	35	18	M16×1.5	52	0.8	11 080	16 860
CF16VM	CF16VMR	CF16VMUU	CF16VMUUR	170	16	35	18	M16×1.5	52	0.8	19 020	34 610
CF18M	CF18MR	CF18MUU	CF18MUUR	250	18	40	20	M18×1.5	58	0.8	13 520	23 180
CF18VM	CF18VMR	CF18VMUU	CF18VMUUR	250	18	40	20	M18×1.5	58	0.8	23 250	47 240
CF20M	CF20MR	CF20MUU	CF20MUUR	460	20	52	24	M20×1.5	66	0.8	19 020	31 830
CF20VM	CF20VMR	CF20VMUU	CF20VMUUR	460	20	52	24	M20×1.5	66	0.8	30 470	59 320
CF20-1M	CF20-1MR	CF20-1MUU	CF20-1MUUR	385	20	47	24	M20×1.5	66	0.8	19 020	31 830
CF20-1VM	CF20-1VMR	CF20-1VMUU	CF20-1VMUUR	385	20	47	24	M20×1.5	66	0.8	30 470	59 320
CF24M	CF24MR	CF24MUU	CF24MUUR	815	24	62	29	M24×1.5	80	0.8	28 040	48 410
CF24VM	CF24VMR	CF24VMUU	CF24VMUUR	815	24	62	29	M24×1.5	80	0.8	42 820	84 650
CF24-1M	CF24-1MR	CF24-1MUU	CF24-1MUUR	1 140	24	72	29	M24×1.5	80	0.8	28 040	48 410
CF24-1VM	CF24-1VMR	CF24-1VMUU	CF24-1VMUUR	1 140	24	72	29	M24×1.5	80	0.8	42 820	84 650
CF30M	CF30MR	CF30MUU	CF30MUUR	1 870	30	80	35	M30×1.5	100	1	41 740	78 250
CF30VM	CF30VMR	CF30VMUU	CF30VMUUR	1 870	30	80	35	M30×1.5	100	1	62 210	132 530
CF30-1M	CF30-1MR	CF30-1MUU	CF30-1MUUR	2 030	30	85	35	M30×1.5	100	1	41 740	78 250
CF30-1VM	CF30-1VMR	CF30-1VMUU	CF30-1VMUUR	2 030	30	85	35	M30×1.5	100	1	62 210	132 530
CF30-2M	CF30-2MR	CF30-2MUU	CF30-2MUUR	2 220	30	90	35	M30×1.5	100	1	41 740	78 250
CF30-2VM	CF30-2VMR	CF30-2VMUU	CF30-2VMUUR	2 220	30	90	35	M30×1.5	100	1	62 210	132 530

Stud diameter (d) 5 to 10mm : Without oil hole in the thread side.(except "K" type)



INTERCHANGE

CAM FOLLOWERS STAINLESS STEEL

HEXAGON SOCKET ON THREAD SIDE
SCREWDRIVER SLOT HEAD

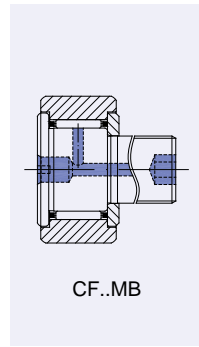
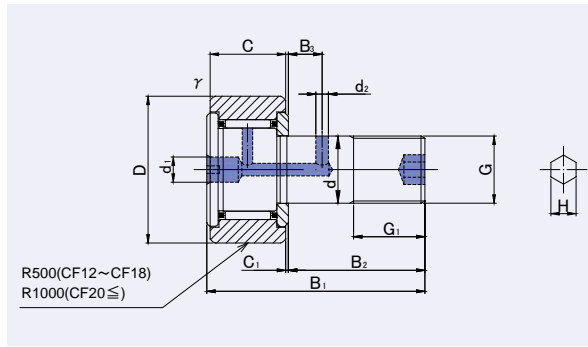

CF..MB, MRB, MUUB, MUURB

DIMENSION TABLE

JNS NUMBER CYLINDRICAL OUTER RING WITHOUT SEALS	JNS NUMBER CROWNED OUTER RING WITHOUT SEALS	JNS NUMBER CYLINDRICAL OUTER RING WITH SEALS	JNS NUMBER CROWNED OUTER RING WITH SEALS	Mass (Approx.)	Dimensions(mm)						Basic dynamic load rating	Basic static load rating
CF..MB	CF..MRB	CF..MUUB	CF..MUURB	g	d	D	C	G	B1	C1	Cr N	Cor N
CF12MB	CF12MRB	CF12MUUB	CF12MUURB	95	12	30	14	M12×1.5	40	0.6	7 300	9 010
CF12VMB	CF12VMRB	CF12VMUUB	CF12VMUURB	95	12	30	14	M12×1.5	40	0.6	12 350	18 120
CF12-1MB	CF12-1MRB	CF12-1MUUB	CF12-1MUURB	105	12	32	14	M12×1.5	40	0.6	7 300	9 010
CF12-1VMB	CF12-1VMRB	CF12-1VMUUB	CF12-1VMUURB	105	12	32	14	M12×1.5	40	0.6	12 350	18 120
CF16MB	CF16MRB	CF16MUUB	CF16MUURB	170	16	35	18	M16×1.5	52	0.8	11 080	16 860
CF16VMB	CF16VMRB	CF16VMUUB	CF16VMUURB	170	16	35	18	M16×1.5	52	0.8	19 020	34 610
CF18MB	CF18MRB	CF18MUUB	CF18MUURB	250	18	40	20	M18×1.5	58	0.8	13 520	23 180
CF18VMB	CF18VMRB	CF18VMUUB	CF18VMUURB	250	18	40	20	M18×1.5	58	0.8	23 250	47 240
CF20MB	CF20MRB	CF20MUUB	CF20MUURB	460	20	52	24	M20×1.5	66	0.8	19 020	31 830
CF20VMB	CF20VMRB	CF20VMUUB	CF20VMUURB	460	20	52	24	M20×1.5	66	0.8	30 470	59 320
CF20-1MB	CF20-1MRB	CF20-1MUUB	CF20-1MUURB	385	20	47	24	M20×1.5	66	0.8	19 020	31 830
CF20-1VMB	CF20-1VMRB	CF20-1VMUUB	CF20-1VMUURB	385	20	47	24	M20×1.5	66	0.8	30 470	59 320
CF24MB	CF24MRB	CF24MUUB	CF24MUURB	815	24	62	29	M24×1.5	80	0.8	28 040	48 410
CF24VMB	CF24VMRB	CF24VMUUB	CF24VMUURB	815	24	62	29	M24×1.5	80	0.8	42 820	84 650
CF24-1MB	CF24-1MRB	CF24-1MUUB	CF24-1MUURB	1 140	24	72	29	M24×1.5	80	0.8	28 040	48 410
CF24-1VMB	CF24-1VMRB	CF24-1VMUUB	CF24-1VMUURB	1 140	24	72	29	M24×1.5	80	0.8	42 820	84 650
CF30MB	CF30MRB	CF30MUUB	CF30MUURB	1 870	30	80	35	M30×1.5	100	1	41 740	78 250
CF30VMB	CF30VMRB	CF30VMUUB	CF30VMUURB	1 870	30	80	35	M30×1.5	100	1	62 210	132 530
CF30-1MB	CF30-1MRB	CF30-1MUUB	CF30-1MUURB	2 030	30	85	35	M30×1.5	100	1	41 740	78 250
CF30-1VMB	CF30-1VMRB	CF30-1VMUUB	CF30-1VMUURB	2 030	30	85	35	M30×1.5	100	1	62 210	132 530
CF30-2MB	CF30-2MRB	CF30-2MUUB	CF30-2MUURB	2 220	30	90	35	M30×1.5	100	1	41 740	78 250
CF30-2VMB	CF30-2VMRB	CF30-2VMUUB	CF30-2VMUURB	2 220	30	90	35	M30×1.5	100	1	62 210	132 530



INTERCHANGE

CAM FOLLOWERS STAINLESS STEEL SOLID ECCENTRIC TYPE HEXAGON SOCKET ON STUD HEAD

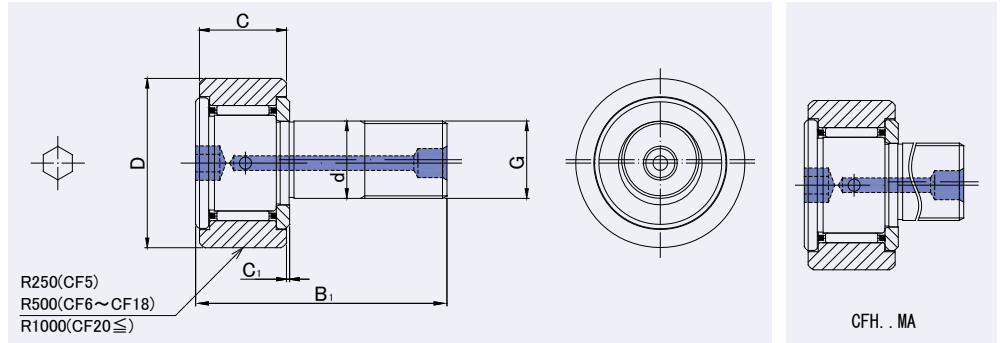

CFH..MA, MRA, MUUA, MUURA

DIMENSION TABLE

JNS NUMBER CYLINDRICAL OUTER RING WITHOUT SEALS	JNS NUMBER CROWNED OUTER RING WITHOUT SEALS	JNS NUMBER CYLINDRICAL OUTER RING WITH SEALS	JNS NUMBER CROWNED OUTER RING WITH SEALS	Mass (Approx.) g	Dimensions(mm)						Basic dynamic load rating Cr N	Basic static load rating Cor N
					d	D	C	G	B1	C1		
CFH5MA	CFH5MRA	CFH5MUUA	CFH5MUURA	10.5	5	13	9	M5×0.8	23	0.5	2 880	2 540
CFH5VMA	CFH5VMRA	CFH5VMUUA	CFH5VMUURA	10.5	5	13	9	M5×0.8	23	0.5	4 690	5 060
CFH6MA	CFH6MRA	CFH6MUUA	CFH6MUURA	18.5	6	16	11	M6×1	28	0.6	3 330	3 330
CFH6VMA	CFH6VMRA	CFH6VMUUA	CFH6VMUURA	18.5	6	16	11	M6×1	28	0.6	6 400	7 840
CFH8MA	CFH8MRA	CFH8MUUA	CFH8MUURA	28.5	8	19	11	M8×1.25	32	0.6	3 960	4 330
CFH8VMA	CFH8VMRA	CFH8VMUUA	CFH8VMUURA	28.5	8	19	11	M8×1.25	32	0.6	7 470	10 270
CFH10MA	CFH10MRA	CFH10MUUA	CFH10MUURA	45	10	22	12	M10×1.25	36	0.6	4 950	6 310
CFH10VMA	CFH10VMRA	CFH10VMUUA	CFH10VMUURA	45	10	22	12	M10×1.25	36	0.6	8 740	13 340
CFH10-1MA	CFH10-1MRA	CFH10-1MUUA	CFH10-1MUURA	60	10	26	12	M10×1.25	36	0.6	4 950	6 310
CFH10-1VMA	CFH10-1VMRA	CFH10-1VMUUA	CFH10-1VMUURA	60	10	26	12	M10×1.25	36	0.6	8 740	13 340
CFH12MA	CFH12MRA	CFH12MUUA	CFH12MUURA	95	12	30	14	M12×1.5	40	0.6	7 300	9 010
CFH12VMA	CFH12VMRA	CFH12VMUUA	CFH12VMUURA	95	12	30	14	M12×1.5	40	0.6	12 350	18 120
CFH12-1MA	CFH12-1MRA	CFH12-1MUUA	CFH12-1MUURA	105	12	32	14	M12×1.5	40	0.6	7 300	9 010
CFH12-1VMA	CFH12-1VMRA	CFH12-1VMUUA	CFH12-1VMUURA	105	12	32	14	M12×1.5	40	0.6	12 350	18 120
CFH16MA	CFH16MRA	CFH16MUUA	CFH16MUURA	170	16	35	18	M16×1.5	52	0.8	11 080	16 860
CFH16VMA	CFH16VMRA	CFH16VMUUA	CFH16VMUURA	170	16	35	18	M16×1.5	52	0.8	19 020	34 610
CFH18MA	CFH18MRA	CFH18MUUA	CFH18MUURA	250	18	40	20	M18×1.5	58	0.8	13 520	23 180
CFH18VMA	CFH18VMRA	CFH18VMUUA	CFH18VMUURA	250	18	40	20	M18×1.5	58	0.8	23 250	47 240
CFH20MA	CFH20MRA	CFH20MUUA	CFH20MUURA	460	20	52	24	M20×1.5	66	0.8	19 020	31 830
CFH20VMA	CFH20VMRA	CFH20VMUUA	CFH20VMUURA	460	20	52	24	M20×1.5	66	0.8	30 470	59 320
CFH20-1MA	CFH20-1MRA	CFH20-1MUUA	CFH20-1MUURA	385	20	47	24	M20×1.5	66	0.8	19 020	31 830
CFH20-1VMA	CFH20-1VMRA	CFH20-1VMUUA	CFH20-1VMUURA	385	20	47	24	M20×1.5	66	0.8	30 470	59 320
CFH24MA	CFH24MRA	CFH24MUUA	CFH24MUURA	815	24	62	29	M24×1.5	80	0.8	28 040	48 410
CFH24VMA	CFH24VMRA	CFH24VMUUA	CFH24VMUURA	815	24	62	29	M24×1.5	80	0.8	42 820	84 650
CFH24-1MA	CFH24-1MRA	CFH24-1MUUA	CFH24-1MUURA	1 140	24	72	29	M24×1.5	80	0.8	28 040	48 410
CFH24-1VMA	CFH24-1VMRA	CFH24-1VMUUA	CFH24-1VMUURA	1 140	24	72	29	M24×1.5	80	0.8	42 820	84 650
CFH30MA	CFH30MRA	CFH30MUUA	CFH30MUURA	1 870	30	80	35	M30×1.5	100	1	41 740	78 250
CFH30VMA	CFH30VMRA	CFH30VMUUA	CFH30VMUURA	1 870	30	80	35	M30×1.5	100	1	62 210	132 530
CFH30-1MA	CFH30-1MRA	CFH30-1MUUA	CFH30-1MUURA	2 030	30	85	35	M30×1.5	100	1	41 740	78 250
CFH30-1VMA	CFH30-1VMRA	CFH30-1VMUUA	CFH30-1VMUURA	2 030	30	85	35	M30×1.5	100	1	62 210	132 530
CFH30-2MA	CFH30-2MRA	CFH30-2MUUA	CFH30-2MUURA	2 220	30	90	35	M30×1.5	100	1	41 740	78 250
CFH30-2VMA	CFH30-2VMRA	CFH30-2VMUUA	CFH30-2VMUURA	2 220	30	90	35	M30×1.5	100	1	62 210	132 530

Stud diameter (d) 5 to 10mm : No grease refilling hole is provided



INTERCHANGE

**CAM FOLLOWERS
STAINLESS STEEL**
SOLID ECCENTRIC TYPE
HEXAGON SOCKET ON BOTH SIDES
GREASE NIPPLE INSTALLED

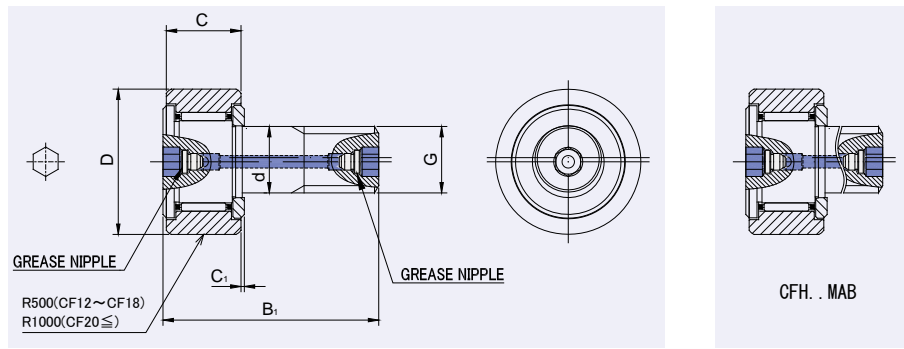

CFH..MAB, MRAB, MUUAB, MUURAB

DIMENSION TABLE

JNS NUMBER CYLINDRICAL OUTER RING WITHOUT SEALS	JNS NUMBER CROWNED OUTER RING WITHOUT SEALS	JNS NUMBER CYLINDRICAL OUTER RING WITH SEALS	JNS NUMBER CROWNED OUTER RING WITH SEALS	Mass (Approx.)	Dimensions(mm)						Basic dynamic load rating	Basic static load rating
					g	d	D	C	G	B1		
CFH12MAB	CFH12RMAB	CFH12MUUAB	CFH12MUURAB	95	12	30	14	M12×1.5	40	0.6	7 300	9 010
CFH12MVAB	CFH12VMRAB	CFH12VMUAB	CFH12VMUURAB	95	12	30	14	M12×1.5	40	0.6	12 350	18 120
CFH12-1MAB	CFH12-1RMAB	CFH12-1MUAB	CFH12-1MUURAB	105	12	32	14	M12×1.5	40	0.6	7 300	9 010
CFH12-1MVAB	CFH12-1VMRAB	CFH12-1VMUAB	CFH12-1VMUURAB	105	12	32	14	M12×1.5	40	0.6	12 350	18 120
CFH16MAB	CFH16RMAB	CFH16MUUAB	CFH16MUURAB	170	16	35	18	M16×1.5	52	0.8	11 080	16 860
CFH16MVAB	CFH16VMRAB	CFH16VMUAB	CFH16VMUURAB	170	16	35	18	M16×1.5	52	0.8	19 020	34 610
CFH18MAB	CFH18RMAB	CFH18MUUAB	CFH18MUURAB	250	18	40	20	M18×1.5	58	0.8	13 520	23 180
CFH18MVAB	CFH18VMRAB	CFH18VMUAB	CFH18VMUURAB	250	18	40	20	M18×1.5	58	0.8	23 250	47 240
CFH20MAB	CFH20RMAB	CFH20MUUAB	CFH20MUURAB	460	20	52	24	M20×1.5	66	0.8	19 020	31 830
CFH20MVAB	CFH20VMRAB	CFH20VMUAB	CFH20VMUURAB	460	20	52	24	M20×1.5	66	0.8	30 470	59 320
CFH20-1MAB	CFH20-1RMAB	CFH20-1MUAB	CFH20-1MUURAB	385	20	47	24	M20×1.5	66	0.8	19 020	31 830
CFH20-1MVAB	CFH20-1VMRAB	CFH20-1VMUAB	CFH20-1VMUURAB	385	20	47	24	M20×1.5	66	0.8	30 470	59 320
CFH24MAB	CFH24RMAB	CFH24MUUAB	CFH24MUURAB	815	24	62	29	M24×1.5	80	0.8	28 040	48 410
CFH24MVAB	CFH24VMRAB	CFH24VMUAB	CFH24VMUURAB	815	24	62	29	M24×1.5	80	0.8	42 820	84 650
CFH24-1MAB	CFH24-1RMAB	CFH24-1MUAB	CFH24-1MUURAB	1 140	24	72	29	M24×1.5	80	0.8	28 040	48 410
CFH24-1MVAB	CFH24-1VMRAB	CFH24-1VMUAB	CFH24-1VMUURAB	1 140	24	72	29	M24×1.5	80	0.8	42 820	84 650
CFH30MAB	CFH30RMAB	CFH30MUUAB	CFH30MUURAB	1 870	30	80	35	M30×1.5	100	1	41 740	78 250
CFH30MVAB	CFH30VMRAB	CFH30VMUAB	CFH30VMUURAB	1 870	30	80	35	M30×1.5	100	1	62 210	132 530
CFH30-1MAB	CFH30-1RMAB	CFH30-1MUAB	CFH30-1MUURAB	2 030	30	85	35	M30×1.5	100	1	41 740	78 250
CFH30-1MVAB	CFH30-1VMRAB	CFH30-1VMUAB	CFH30-1VMUURAB	2 030	30	85	35	M30×1.5	100	1	62 210	132 530
CFH30-2MAB	CFH30-2RMAB	CFH30-2MUAB	CFH30-2MUURAB	2 220	30	90	35	M30×1.5	100	1	41 740	78 250
CFH30-2MVAB	CFH30-2VMRAB	CFH30-2VMUAB	CFH30-2VMUURAB	2 220	30	90	35	M30×1.5	100	1	62 210	132 530



INTERCHANGE

CAM FOLLOWERS STAINLESS STEEL SOLID ECCENTRIC TYPE SCREWDRIVER SLOT HEAD

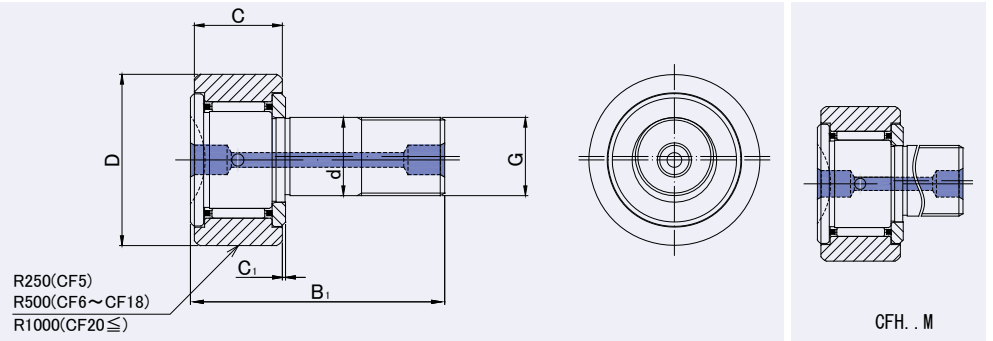

CFH..M, MR, MUU, MUUR

DIMENSION TABLE

JNS NUMBER CYLINDRICAL OUTER RING	JNS NUMBER CROWNED OUTER RING	JNS NUMBER CYLINDRICAL OUTER RING WITH SEALS	JNS NUMBER CROWNED OUTER RING WITH SEALS	Mass (Approx.) g	Dimensions(mm)						Basic dynamic load rating Cr N	Basic static load rating Cor N
					d	D	C	G	B1	C1		
CFH5M	CFH5MR	CFH5MUU	CFH5MUUR	10.5	5	13	9	M5×0.8	23	0.5	2 880	2 540
CFH5VM	CFH5VMR	CFH5VMUU	CFH5VMUUR	10.5	5	13	9	M5×0.8	23	0.5	4 690	5 060
CFH6M	CFH6MR	CFH6MUU	CFH6MUUR	18.5	6	16	11	M6×1	28	0.6	3 330	3 330
CFH6VM	CFH6VMR	CFH6VMUU	CFH6VMUUR	18.5	6	16	11	M6×1	28	0.6	6 400	7 840
CFH8M	CFH8MR	CFH8MUU	CFH8MUUR	28.5	8	19	11	M8×1.25	32	0.6	3 960	4 330
CFH8VM	CFH8VMR	CFH8VMUU	CFH8VMUUR	28.5	8	19	11	M8×1.25	32	0.6	7 470	10 270
CFH10M	CFH10MR	CFH10MUU	CFH10MUUR	45	10	22	12	M10×1.25	36	0.6	4 950	6 310
CFH10VM	CFH10VMR	CFH10VMUU	CFH10VMUUR	45	10	22	12	M10×1.25	36	0.6	8 740	13 340
CFH10-1M	CFH10-1MR	CFH10-1MUU	CFH10-1MUUR	60	10	26	12	M10×1.25	36	0.6	4 950	6 310
CFH10-1VM	CFH10-1VMR	CFH10-1VMUU	CFH10-1VMUUR	60	10	26	12	M10×1.25	36	0.6	8 740	13 340
CFH12M	CFH12MR	CFH12MUU	CFH12MUUR	95	12	30	14	M12×1.5	40	0.6	7 300	9 010
CFH12VM	CFH12VMR	CFH12VMUU	CFH12VMUUR	95	12	30	14	M12×1.5	40	0.6	12 350	18 120
CFH12-1M	CFH12-1MR	CFH12-1MUU	CFH12-1MUUR	105	12	32	14	M12×1.5	40	0.6	7 300	9 010
CFH12-1VM	CFH12-1VMR	CFH12-1VMUU	CFH12-1VMUUR	105	12	32	14	M12×1.5	40	0.6	12 350	18 120
CFH16M	CFH16MR	CFH16MUU	CFH16MUUR	170	16	35	18	M16×1.5	52	0.8	11 080	16 860
CFH16VM	CFH16VMR	CFH16VMUU	CFH16VMUUR	170	16	35	18	M16×1.5	52	0.8	19 020	34 610
CFH18M	CFH18MR	CFH18MUU	CFH18MUUR	250	18	40	20	M18×1.5	58	0.8	13 520	23 180
CFH18VM	CFH18VMR	CFH18VMUU	CFH18VMUUR	250	18	40	20	M18×1.5	58	0.8	23 250	47 240
CFH20M	CFH20MR	CFH20MUU	CFH20MUUR	460	20	52	24	M20×1.5	66	0.8	19 020	31 830
CFH20VM	CFH20VMR	CFH20VMUU	CFH20VMUUR	460	20	52	24	M20×1.5	66	0.8	30 470	59 320
CFH20-1M	CFH20-1MR	CFH20-1MUU	CFH20-1MUUR	385	20	47	24	M20×1.5	66	0.8	19 020	31 830
CFH20-1VM	CFH20-1VMR	CFH20-1VMUU	CFH20-1VMUUR	385	20	47	24	M20×1.5	66	0.8	30 470	59 320
CFH24M	CFH24MR	CFH24MUU	CFH24MUUR	815	24	62	29	M24×1.5	80	0.8	28 040	48 410
CFH24VM	CFH24VMR	CFH24VMUU	CFH24VMUUR	815	24	62	29	M24×1.5	80	0.8	42 820	84 650
CFH24-1M	CFH24-1MR	CFH24-1MUU	CFH24-1MUUR	1 140	24	72	29	M24×1.5	80	0.8	28 040	48 410
CFH24-1VM	CFH24-1VMR	CFH24-1VMUU	CFH24-1VMUUR	1 140	24	72	29	M24×1.5	80	0.8	42 820	84 650
CFH30M	CFH30MR	CFH30MUU	CFH30MUUR	1 870	30	80	35	M30×1.5	100	1	41 740	78 250
CFH30VM	CFH30VMR	CFH30VMUU	CFH30VMUUR	1 870	30	80	35	M30×1.5	100	1	62 210	132 530
CFH30-1M	CFH30-1MR	CFH30-1MUU	CFH30-1MUUR	2 030	30	85	35	M30×1.5	100	1	41 740	78 250
CFH30-1VM	CFH30-1VMR	CFH30-1VMUU	CFH30-1VMUUR	2 030	30	85	35	M30×1.5	100	1	62 210	132 530
CFH30-2M	CFH30-2MR	CFH30-2MUU	CFH30-2MUUR	2 220	30	90	35	M30×1.5	100	1	41 740	78 250
CFH30-2VM	CFH30-2VMR	CFH30-2VMUU	CFH30-2VMUUR	2 220	30	90	35	M30×1.5	100	1	62 210	132 530

Stud diameter (d) 5 to 10mm : Without oil hole in the thread side.



INTERCHANGE

CAM FOLLOWERS STAINLESS STEEL

SOLID ECCENTRIC TYPE
HEXAGON SOCKET ON THREAD SIDE
SCREWDRIVER SLOT HEAD

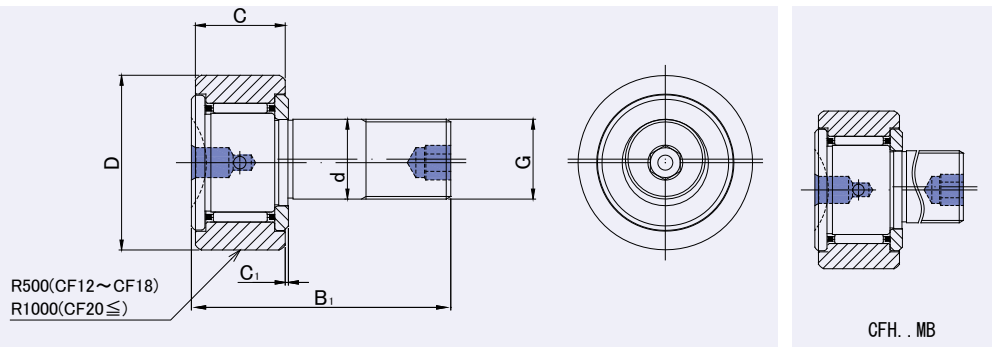

CFH..MB

CFH..MB, MRB, MUUB, MUURB

DIMENSION TABLE

JNS NUMBER CYLINDRICAL OUTER RING	JNS NUMBER CROWNED OUTER RING	JNS NUMBER CYLINDRICAL OUTER RING WITH SEALS	JNS NUMBER CROWNED OUTER RING WITH SEALS	Mass (Approx.) g	Dimensions(mm)						Basic dynamic load rating Cr N	Basic static load rating Cor N
					d	D	C	G	B1	C1		
CFH12MB	CFH12MRB	CFH12MUUB	CFH12MUURB	95	12	30	14	M12×1.5	40	0.6	7 300	9 010
CFH12VMB	CFH12VMRB	CFH12VMUUB	CFH12VMUURB	95	12	30	14	M12×1.5	40	0.6	12 350	18 120
CFH12-1MB	CFH12-1MRB	CFH12-1MUUB	CFH12-1MUURB	105	12	32	14	M12×1.5	40	0.6	7 300	9 010
CFH12-1VMB	CFH12-1VMRB	CFH12-1VMUUB	CFH12-1VMUURB	105	12	32	14	M12×1.5	40	0.6	12 350	18 120
CFH16MB	CFH16MRB	CFH16MUUB	CFH16MUURB	170	16	35	18	M16×1.5	52	0.8	11 080	16 860
CFH16VMB	CFH16VMRB	CFH16VMUUB	CFH16VMUURB	170	16	35	18	M16×1.5	52	0.8	19 020	34 610
CFH18MB	CFH18MRB	CFH18MUUB	CFH18MUURB	250	18	40	20	M18×1.5	58	0.8	13 520	23 180
CFH18VMB	CFH18VMRB	CFH18VMUUB	CFH18VMUURB	250	18	40	20	M18×1.5	58	0.8	23 250	47 240
CFH20MB	CFH20MRB	CFH20MUUB	CFH20MUURB	460	20	52	24	M20×1.5	66	0.8	19 020	31 830
CFH20VMB	CFH20VMRB	CFH20VMUUB	CFH20VMUURB	460	20	52	24	M20×1.5	66	0.8	30 470	59 320
CFH20-1MB	CFH20-1MRB	CFH20-1MUUB	CFH20-1MUURB	385	20	47	24	M20×1.5	66	0.8	19 020	31 830
CFH20-1VMB	CFH20-1VMRB	CFH20-1VMUUB	CFH20-1VMUURB	385	20	47	24	M20×1.5	66	0.8	30 470	59 320
CFH24MB	CFH24MRB	CFH24MUUB	CFH24MUURB	815	24	62	29	M24×1.5	80	0.8	28 040	48 410
CFH24VMB	CFH24VMRB	CFH24VMUUB	CFH24VMUURB	815	24	62	29	M24×1.5	80	0.8	42 820	84 650
CFH24-1MB	CFH24-1MRB	CFH24-1MUUB	CFH24-1MUURB	1 140	24	72	29	M24×1.5	80	0.8	28 040	48 410
CFH24-1VMB	CFH24-1VMRB	CFH24-1VMUUB	CFH24-1VMUURB	1 140	24	72	29	M24×1.5	80	0.8	42 820	84 650
CFH30MB	CFH30MRB	CFH30MUUB	CFH30MUURB	1 870	30	80	35	M30×1.5	100	1	41 740	78 250
CFH30VMB	CFH30VMRB	CFH30VMUUB	CFH30VMUURB	1 870	30	80	35	M30×1.5	100	1	62 210	132 530
CFH30-1MB	CFH30-1MRB	CFH30-1MUUB	CFH30-1MUURB	2 030	30	85	35	M30×1.5	100	1	41 740	78 250
CFH30-1VMB	CFH30-1VMRB	CFH30-1VMUUB	CFH30-1VMUURB	2 030	30	85	35	M30×1.5	100	1	62 210	132 530
CFH30-2MB	CFH30-2MRB	CFH30-2MUUB	CFH30-2MUURB	2 220	30	90	35	M30×1.5	100	1	41 740	78 250
CFH30-2VMB	CFH30-2VMRB	CFH30-2VMUUB	CFH30-2VMUURB	2 220	30	90	35	M30×1.5	100	1	62 210	132 530



INTERCHANGE

CAM FOLLOWERS STAINLESS STEEL

TAP HOLE FOR PIPING
SCREWDRIVER SLOT HEAD

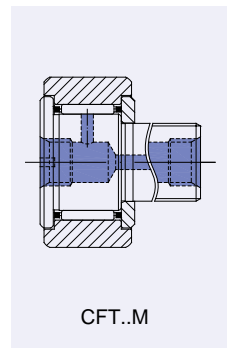
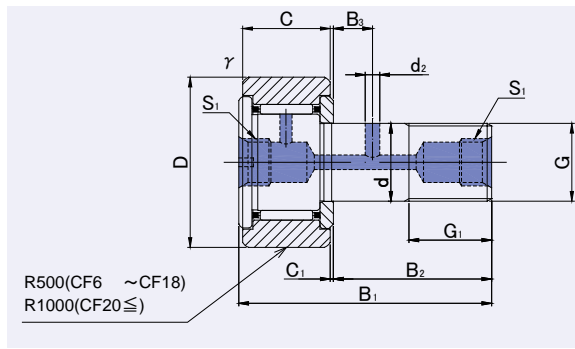

CFT..M, MR, MUU, MUUR

DIMENSION TABLE

JNS NUMBER CYLINDRICAL OUTER RING	JNS NUMBER CROWNED OUTER RING	JNS NUMBER CYLINDRICAL OUTER RING WITH SEALS	JNS NUMBER CROWNED OUTER RING WITH SEALS	Mass (Approx.) g	Dimensions(mm)						Basic dynamic load rating Cr N	Basic static load rating Cor N
					d	D	C	G	B1	C1		
CFT6M	CFT6MR	CFT6MUU	CFT6MUUR	18.5	6	16	11	M6×1	28	0.6	3 330	3 330
CFT6VM	CFT6VMR	CFT6VMUU	CFT6VMUUR	18.5	6	16	11	M6×1	28	0.6	6 400	7 840
CFT8M	CFT8MR	CFT8MUU	CFT8MUUR	28.5	8	19	11	M8×1.25	32	0.6	3 960	4 330
CFT8VM	CFT8VMR	CFT8VMUU	CFT8VMUUR	28.5	8	19	11	M8×1.25	32	0.6	7 470	10 270
CFT10M	CFT10MR	CFT10MUU	CFT10MUUR	45	10	22	12	M10×1.25	36	0.6	4 950	6 310
CFT10VM	CFT10VMR	CFT10VMUU	CFT10VMUUR	45	10	22	12	M10×1.25	36	0.6	8 740	13 340
CFT10-1M	CFT10-1MR	CFT10-1MUU	CFT10-1MUUR	60	10	26	12	M10×1.25	36	0.6	4 950	6 310
CFT10-1VM	CFT10-1VMR	CFT10-1VMUU	CFT10-1VMUUR	60	10	26	12	M10×1.25	36	0.6	8 740	13 340
CFT12M	CFT12MR	CFT12MUU	CFT12MUUR	95	12	30	14	M12×1.5	40	0.6	7 300	9 010
CFT12VM	CFT12VMR	CFT12VMUU	CFT12VMUUR	95	12	30	14	M12×1.5	40	0.6	12 350	18 120
CFT12-1M	CFT12-1MR	CFT12-1MUU	CFT12-1MUUR	105	12	32	14	M12×1.5	40	0.6	7 300	9 010
CFT12-1VM	CFT12-1VMR	CFT12-1VMUU	CFT12-1VMUUR	105	12	32	14	M12×1.5	40	0.6	12 350	18 120
CFT16M	CFT16MR	CFT16MUU	CFT16MUUR	170	16	35	18	M16×1.5	52	0.8	11 080	16 860
CFT16VM	CFT16VMR	CFT16VMUU	CFT16VMUUR	170	16	35	18	M16×1.5	52	0.8	19 020	34 610
CFT18M	CFT18MR	CFT18MUU	CFT18MUUR	250	18	40	20	M18×1.5	58	0.8	13 520	23 180
CFT18VM	CFT18VMR	CFT18VMUU	CFT18VMUUR	250	18	40	20	M18×1.5	58	0.8	23 250	47 240
CFT20M	CFT20MR	CFT20MUU	CFT20MUUR	460	20	52	24	M20×1.5	66	0.8	19 020	31 830
CFT20VM	CFT20VMR	CFT20VMUU	CFT20VMUUR	460	20	52	24	M20×1.5	66	0.8	30 470	59 320
CFT20-1M	CFT20-1MR	CFT20-1MUU	CFT20-1MUUR	385	20	47	24	M20×1.5	66	0.8	19 020	31 830
CFT20-1VM	CFT20-1VMR	CFT20-1VMUU	CFT20-1VMUUR	385	20	47	24	M20×1.5	66	0.8	30 470	59 320
CFT24M	CFT24MR	CFT24MUU	CFT24MUUR	815	24	62	29	M24×1.5	80	0.8	28 040	48 410
CFT24VM	CFT24VMR	CFT24VMUU	CFT24VMUUR	815	24	62	29	M24×1.5	80	0.8	42 820	84 650
CFT24-1M	CFT24-1MR	CFT24-1MUU	CFT24-1MUUR	1 140	24	72	29	M24×1.5	80	0.8	28 040	48 410
CFT24-1VM	CFT24-1VMR	CFT24-1VMUU	CFT24-1VMUUR	1 140	24	72	29	M24×1.5	80	0.8	42 820	84 650
CFT30M	CFT30MR	CFT30MUU	CFT30MUUR	1 870	30	80	35	M30×1.5	100	1	41 740	78 250
CFT30VM	CFT30VMR	CFT30VMUU	CFT30VMUUR	1 870	30	80	35	M30×1.5	100	1	62 210	132 530
CFT30-1M	CFT30-1MR	CFT30-1MUU	CFT30-1MUUR	2 030	30	85	35	M30×1.5	100	1	41 740	78 250
CFT30-1VM	CFT30-1VMR	CFT30-1VMUU	CFT30-1VMUUR	2 030	30	85	35	M30×1.5	100	1	62 210	132 530
CFT30-2M	CFT30-2MR	CFT30-2MUU	CFT30-2MUUR	2 220	30	90	35	M30×1.5	100	1	41 740	78 250
CFT30-2VM	CFT30-2VMR	CFT30-2VMUU	CFT30-2VMUUR	2 220	30	90	35	M30×1.5	100	1	62 210	132 530

Stud diameter (d) 6 to 10mm : Without oil hole in the thread side.



INTERCHANGE

CAM FOLLOWERS STAINLESS STEEL

TAP HOLE FOR PIPING
HEXAGON SOCKET ON STUD HEAD

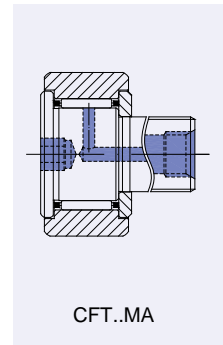
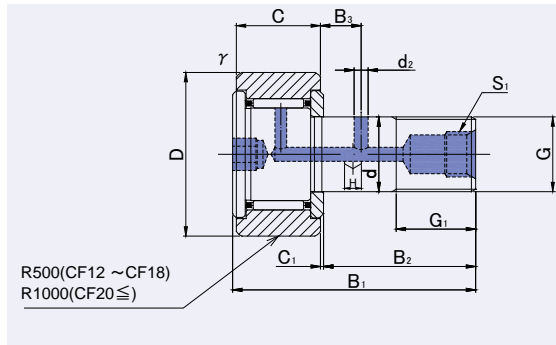

CFT..MA

CFT..MA, MRA, MUUA, MUURA

DIMENSION TABLE

JNS NUMBER CYLINDRICAL OUTER RING	JNS NUMBER CROWNED OUTER RING	JNS NUMBER CYLINDRICAL OUTER RING WITH SEALS	JNS NUMBER CROWNED OUTER RING WITH SEALS	Mass (Approx.) g	Dimensions(mm)						Basic dynamic load rating Cr N	Basic static load rating Cor N
					d	D	C	G	B1	C1		
CFT12MA	CFT12MRA	CFT12MUUA	CFT12MUURA	95	12	30	14	M12×1.5	40	0.6	7 300	9 010
CFT12VMA	CFT12VMRA	CFT12VMUUA	CFT12VMUURA	95	12	30	14	M12×1.5	40	0.6	12 350	18 120
CFT12-1MA	CFT12-1MRA	CFT12-1MUUA	CFT12-1MUURA	105	12	32	14	M12×1.5	40	0.6	7 300	9 010
CFT12-1VMA	CFT12-1VMRA	CFT12-1VMUUA	CFT12-1VMUURA	105	12	32	14	M12×1.5	40	0.6	12 350	18 120
CFT16MA	CFT16MRA	CFT16MUUA	CFT16MUURA	170	16	35	18	M16×1.5	52	0.8	11 080	16 860
CFT16VMA	CFT16VMRA	CFT16VMUUA	CFT16VMUURA	170	16	35	18	M16×1.5	52	0.8	19 020	34 610
CFT18MA	CFT18MRA	CFT18MUUA	CFT18MUURA	250	18	40	20	M18×1.5	58	0.8	13 520	23 180
CFT18VMA	CFT18VMRA	CFT18VMUUA	CFT18VMUURA	250	18	40	20	M18×1.5	58	0.8	23 250	47 240
CFT20MA	CFT20MRA	CFT20MUUA	CFT20MUURA	460	20	52	24	M20×1.5	66	0.8	19 020	31 830
CFT20VMA	CFT20VMRA	CFT20VMUUA	CFT20VMUURA	460	20	52	24	M20×1.5	66	0.8	30 470	59 320
CFT20-1MA	CFT20-1MRA	CFT20-1MUUA	CFT20-1MUURA	385	20	47	24	M20×1.5	66	0.8	19 020	31 830
CFT20-1VMA	CFT20-1VMRA	CFT20-1VMUUA	CFT20-1VMUURA	385	20	47	24	M20×1.5	66	0.8	30 470	59 320
CFT24MA	CFT24MRA	CFT24MUUA	CFT24MUURA	815	24	62	29	M24×1.5	80	0.8	28 040	48 410
CFT24VMA	CFT24VMRA	CFT24VMUUA	CFT24VMUURA	815	24	62	29	M24×1.5	80	0.8	42 820	84 650
CFT24-1MA	CFT24-1MRA	CFT24-1MUUA	CFT24-1MUURA	1 140	24	72	29	M24×1.5	80	0.8	28 040	48 410
CFT24-1VMA	CFT24-1VMRA	CFT24-1VMUUA	CFT24-1VMUURA	1 140	24	72	29	M24×1.5	80	0.8	42 820	84 650
CFT30MA	CFT30MRA	CFT30MUUA	CFT30MUURA	1 870	30	80	35	M30×1.5	100	1	41 740	78 250
CFT30VMA	CFT30VMRA	CFT30VMUUA	CFT30VMUURA	1 870	30	80	35	M30×1.5	100	1	62 210	132 530
CFT30-1MA	CFT30-1MRA	CFT30-1MUUA	CFT30-1MUURA	2 030	30	85	35	M30×1.5	100	1	41 740	78 250
CFT30-1VMA	CFT30-1VMRA	CFT30-1VMUUA	CFT30-1VMUURA	2 030	30	85	35	M30×1.5	100	1	62 210	132 530
CFT30-2MA	CFT30-2MRA	CFT30-2MUUA	CFT30-2MUURA	2 220	30	90	35	M30×1.5	100	1	41 740	78 250
CFT30-2VMA	CFT30-2VMRA	CFT30-2VMUUA	CFT30-2VMUURA	2 220	30	90	35	M30×1.5	100	1	62 210	132 530



INTERCHANGE

ROLLER FOLLOWERS STAINLESS STEEL

SEPARABLE
WITH INNER RING
WITHOUT INNER RING

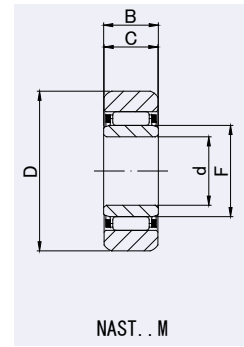
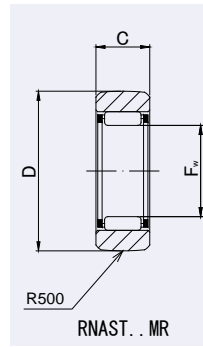
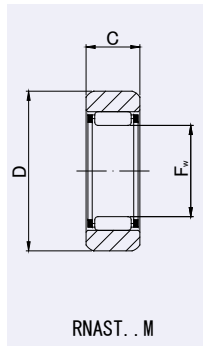

RNAS..M, MR, NAS..M, MR

DIMENSION TABLE

JNS NUMBER CYLINDRICAL OUTER RING WITHOUT INNER RING	JNS NUMBER CROWNED OUTER RING WITHOUT INNER RING	Mass (Approx.)	JNS NUMBER CYLINDRICAL OUTER RING WITH INNER RING	JNS NUMBER CROWNED OUTER RING WITH INNER RING	Mass (Approx.)	Dimensions(mm)					Basic dynamic load rating	Basic static load rating
						Fw (F)	D	d	C	B		
RNAS..M	RNAS..MR	g	NAS..M	NAS..MR	g	Fw (F)	D	d	C	B	Cr N	Cor N
RNAS5M	RNAS5MR	8.9	—	—	—	7	16	—	7.8	—	2 520	2 190
RNAS6M	RNAS6MR	13.9	NAS6M	NAS6MR	17.8	10	19	6	9.8	10	3 790	4 180
RNAS8M	RNAS8MR	23.5	NAS8M	NAS8MR	28	12	24	8	9.8	10	5 220	5 410
RNAS10M	RNAS10MR	42.5	NAS10M	NAS10MR	50	14	30	10	11.8	12	8 920	8 890
RNAS12M	RNAS12MR	49.5	NAS12M	NAS12MR	58	16	32	12	11.8	12	9 560	10 020
RNAS15M	RNAS15MR	50	NAS15M	NAS15MR	62	20	35	15	11.8	12	11 310	13 150
RNAS17M	RNAS17MR	90	NAS17M	NAS17MR	110	22	40	17	15.8	16	16 000	19 220
RNAS20M	RNAS20MR	135	NAS20M	NAS20MR	155	25	47	20	15.8	16	17 660	22 540
RNAS25M	RNAS25MR	152	NAS25M	NAS25MR	180	30	52	25	15.8	16	19 040	26 120
RNAS30M	RNAS30MR	255	NAS30M	NAS30MR	320	38	62	30	19.8	20	27 870	41 760
RNAS35M	RNAS35MR	375	NAS35M	NAS35MR	440	42	72	35	19.8	20	29 620	46 550
RNAS40M	RNAS40MR	420	NAS40M	NAS40MR	530	50	80	40	19.8	20	32 840	56 210
RNAS45M	RNAS45MR	460	NAS45M	NAS45MR	580	55	85	45	19.8	20	34 130	61 080
RNAS50M	RNAS50MR	500	NAS50M	NAS50MR	635	60	90	50	19.8	20	35 600	66 050



INTERCHANGE

ROLLER FOLLOWERS STAINLESS STEEL

SEPARABLE
WITH INNER RING
WITH SHIELD

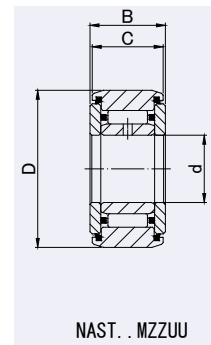
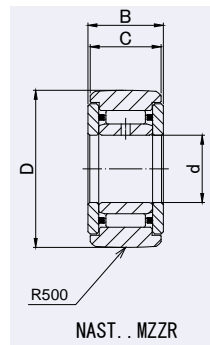
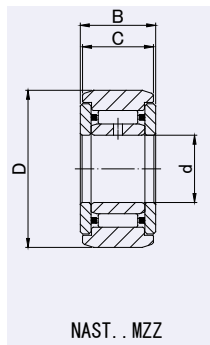

NAST..MZZ, MZZR, MZZUU, MZZUUR

DIMENSION TABLE

JNS NUMBER CYLINDRICAL OUTER RING WITHOUT SEALS	JNS NUMBER CROWNED OUTER RING WITHOUT SEALS	JNS NUMBER CYLINDRICAL OUTER RING WITH SEALS	JNS NUMBER CROWNED OUTER RING WITH SEALS	Mass (Approx.)	Dimensions(mm)				Basic dynamic load rating	Basic static load rating
					d	D	B	C		
NAST..MZZ	NAST..MZZR	NAST..MZZUU	NAST..MZZUUR	g	d	D	B	C	Cr N	Cor N
NAST6MZZ	NAST6MZZR	NAST6MZZUU	NAST6MZZUUR	24.5	6	19	14	13.8	3 790	4 180
NAST8MZZ	NAST8MZZR	NAST8MZZUU	NAST8MZZUUR	39	8	24	14	13.8	5 220	5 410
NAST10MZZ	NAST10MZZR	NAST10MZZUU	NAST10MZZUUR	65	10	30	16	15.8	8 920	8 890
NAST12MZZ	NAST12MZZR	NAST12MZZUU	NAST12MZZUUR	75	12	32	16	15.8	9 560	10 020
NAST15MZZ	NAST15MZZR	NAST15MZZUU	NAST15MZZUUR	83	15	35	16	15.8	11 310	13 150
NAST17MZZ	NAST17MZZR	NAST17MZZUU	NAST17MZZUUR	135	17	40	20	19.8	16 000	19 220
NAST20MZZ	NAST20MZZR	NAST20MZZUU	NAST20MZZUUR	195	20	47	20	19.8	17 660	22 540
NAST25MZZ	NAST25MZZR	NAST25MZZUU	NAST25MZZUUR	225	25	52	20	19.8	19 040	26 120
NAST30MZZ	NAST30MZZR	NAST30MZZUU	NAST30MZZUUR	400	30	62	25	24.8	27 870	41 760
NAST35MZZ	NAST35MZZR	NAST35MZZUU	NAST35MZZUUR	550	35	72	25	24.8	29 620	46 550
NAST40MZZ	NAST40MZZR	NAST40MZZUU	NAST40MZZUUR	710	40	80	26	25.8	32 840	56 210
NAST45MZZ	NAST45MZZR	NAST45MZZUU	NAST45MZZUUR	760	45	85	26	25.8	34 130	61 080
NAST50MZZ	NAST50MZZR	NAST50MZZUU	NAST50MZZUUR	830	50	90	26	25.8	35 600	66 050



INTERCHANGE

ROLLER FOLLOWERS STAINLESS STEEL

NON SEPARABLE
WITH INNER RING

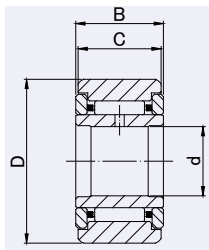

NART..MX

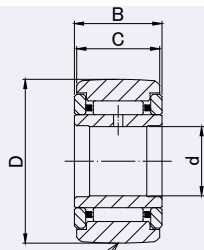

R500(≤NART17)
R1000(NART20≤)

NART..MR

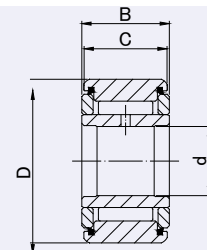

NART..MVX

NART..MX, MR, MUUX, MUUR

DIMENSION TABLE

JNS NUMBER CYLINDRICAL OUTER RING WITHOUT SEALS	JNS NUMBER CROWNED OUTER RING WITHOUT SEALS	JNS NUMBER CYLINDRICAL OUTER RING WITH SEALS	JNS NUMBER CROWNED OUTER RING WITH SEALS	Mass (Approx.)	Dimensions(mm)				Basic dynamic load rating	Basic static load rating
NART..MX	NART..MR	NART..MUUX	NART..MUUR	g	d	D	B	C	Cr N	Cor N
NART5MX	NART5MR	NART5MUUX	NART5MUUR	14.5	5	16	12	11	3 330	3 420
NART5MVX	NART5MVR	NART5MUUVX	NART5MUUVR	15.1	5	16	12	11	6 210	7 670
NART6MX	NART6MR	NART6MUUX	NART6MUUR	20.5	6	19	12	11	3 860	4 320
NART6MVX	NART6MVR	NART6MUUVX	NART6MUUVR	21.5	6	19	12	11	7 020	9 470
NART8MX	NART8MR	NART8MUUX	NART8MUUR	41.5	8	24	15	14	6 070	6 710
NART8MVX	NART8MVR	NART8MUUVX	NART8MUUVR	42.5	8	24	15	14	10 850	14 350
NART10MX	NART10MR	NART10MUUX	NART10MUUR	64.5	10	30	15	14	7 910	7 630
NART10MVX	NART10MVR	NART10MUUVX	NART10MUUVR	66.5	10	30	15	14	14 350	16 650
NART12MX	NART12MR	NART12MUUX	NART12MUUR	71	12	32	15	14	8 370	8 460
NART12MVX	NART12MVR	NART12MUUVX	NART12MUUVR	73	12	32	15	14	15 450	18 860
NART15MX	NART15MR	NART15MUUX	NART15MUUR	102	15	35	19	18	13 240	16 190
NART15MVX	NART15MVR	NART15MUUVX	NART15MUUVR	106	15	35	19	18	23 090	33 480
NART17MX	NART17MR	NART17MUUX	NART17MUUR	149	17	40	21	20	17 110	20 700
NART17MVX	NART17MVR	NART17MUUVX	NART17MUUVR	155	17	40	21	20	29 440	42 500
NART20MX	NART20MR	NART20MUUX	NART20MUUR	250	20	47	25	24	22 170	30 080
NART20MVX	NART20MVR	NART20MUUVX	NART20MUUVR	255	20	47	25	24	38 360	61 910
NART25MX	NART25MR	NART25MUUX	NART25MUUR	285	25	52	25	24	23 730	34 500
NART25MVX	NART25MVR	NART25MUUVX	NART25MUUVR	295	25	52	25	24	41 860	72 680
NART30MX	NART30MR	NART30MUUX	NART30MUUR	470	30	62	29	28	33 300	52 340
NART30MVX	NART30MVR	NART30MUUVX	NART30MUUVR	485	30	62	29	28	55 010	101 560
NART35MX	NART35MR	NART35MUUX	NART35MUUR	640	35	72	29	28	35 140	57 770
NART35MVX	NART35MVR	NART35MUUVX	NART35MUUVR	655	35	72	29	28	57 960	111 780
NART40MX	NART40MR	NART40MUUX	NART40MUUR	845	40	80	32	30	42 500	77 920
NART40MVX	NART40MVR	NART40MUUVX	NART40MUUVR	865	40	80	32	30	70 100	151 060
NART45MX	NART45MR	NART45MUUX	NART45MUUR	915	45	85	32	30	45 350	87 580
NART45MVX	NART45MVR	NART45MUUVX	NART45MUUVR	935	45	85	32	30	73 780	166 610
NART50MX	NART50MR	NART50MUUX	NART50MUUR	980	50	90	32	30	47 010	94 110
NART50MVX	NART50MVR	NART50MUUVX	NART50MUUVR	1 010	50	90	32	30	77 370	182 160



INTERCHANGE

All of JNS products are made in Japan.



HEAD OFFICE

OSAKA, JAPAN

NARA, JAPAN



NARA PLANT

All rights reserved.

* Exterior and/or specification of products listed in the catalog is subject to be changed without advanced notice for improvement purpose.

* While this catalog is prepared with great care for its accuracy, NOSE SEIKO may not be responsible for any damage caused by any typographical error or omission in this catalog.



Certificate No.00088-1999-AQ-KOB-Rva/JAB
NOSE SEIKO CO., LTD. NARA PLANT

NEEDLE ROLLER BEARINGS **STAINLESS STEEL**

